



211-7-1  
11-10  
11-10

Library

ORC



3 9153 01140833 5



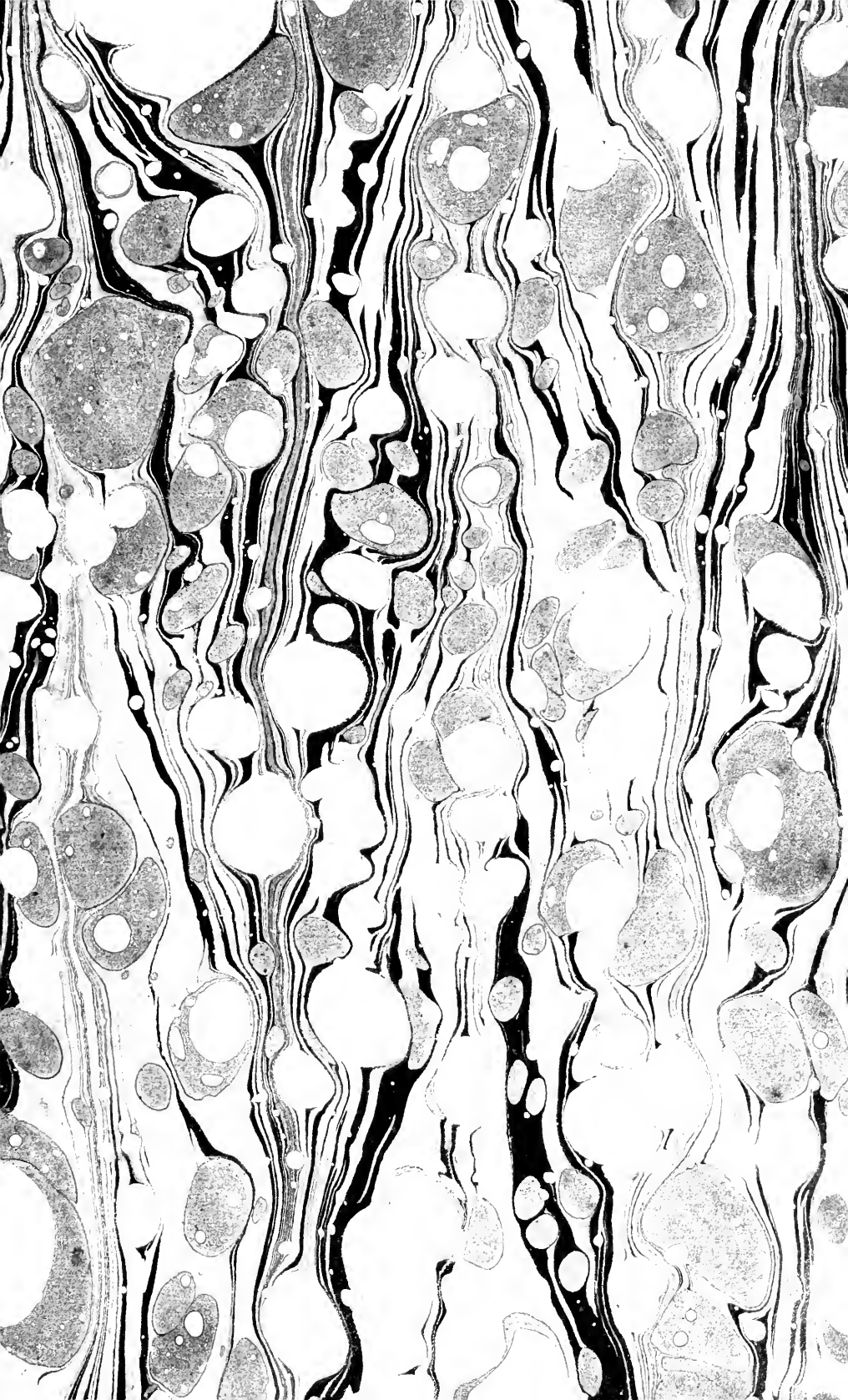















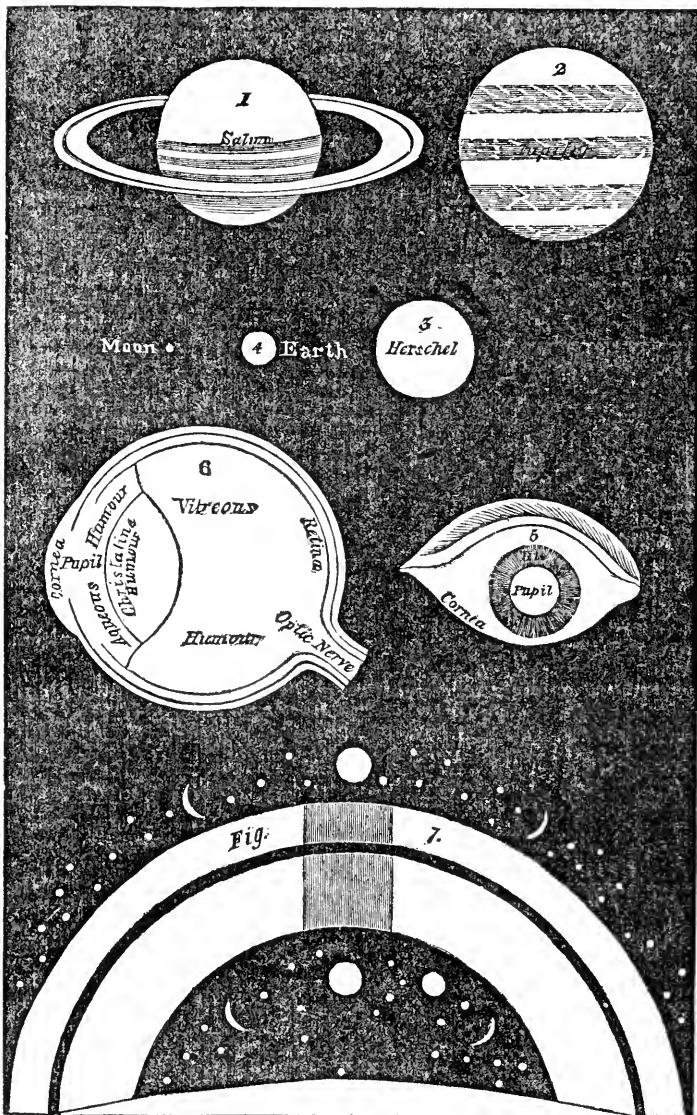

The above engraving represents a view of the rings and moons of Saturn, as they would appear to a spectator from the surface of Saturn, at a point about 15 or 20 degrees north of its equator. The shadow of the body of the planet appears about the middle of the rings at midnight. At sunset this shadow will appear on the eastern side of the rings, and will appear to move gradually onward from east to west until sunrise, when it will disappear from the western side of the rings. See pages 86, 87.

THE

COMPLETE WORKS

OF

THOMAS DICK, LL. D.:

ELEVEN VOLUMES IN TWO.

VOLUME ONE, CONTAINING:

- |  |   |
|--|---|
| I. AN ESSAY ON THE IMPROVEMENT OF SOCIETY. | IV. THE MENTAL ILLUMINATION AND MORAL IMPROVEMENT OF MANKIND. |
| II. THE PHILOSOPHY OF A FUTURE STATE.      | V. AN ESSAY ON THE SIN AND EVILS OF COVETOUSNESS.             |
| III. THE PHILOSOPHY OF RELIGION.           |   |

VOLUME TWO, CONTAINING:

- |   |  |
|---|--|
| I. THE CHRISTIAN PHILOSOPHER; OR, SCIENCE AND RELIGION. | IV. THE PRACTICAL ASTRONOMER.                    |
| II. CELESTIAL SCENERY—ILLUSTRATED.                      | V. THE SOLAR SYSTEM—ITS WONDERS.                 |
| III. SIDEREAL HEAVENS, PLANETS, ETC.                    | VI. THE ATMOSPHERE, AND ATMOSPHERICAL PHENOMENA. |

ILLUSTRATED WITH ENGRAVINGS,  
AND A PORTRAIT OF THE AUTHOR.

---

VOL. II.

---

CINCINNATI:

APPLEGATE & CO., PUBLISHERS,

NO. 43 MAIN STREET.

1856.

1901  

---

~~1901~~  
1901  

---



**T H E**

**CHRISTIAN PHILOSOPHER;**

**O R,**

**THE CONNECTION OF SCIENCE AND PHILOSOPHY WITH  
RELIGION.**

**FROM THE LAST LONDON EDITION.**



## P R E F A C E.

---

THE following pages were written under the impression, that the visible manifestations of the attributes of the Deity are too frequently overlooked by Christians in their views of the great objects of Religion, and in the worship they offer to the Father of their spirits; and are intended to show, that the teachers of Religion, in imparting instruction either to the old or to the young, ought to embrace a wider range of illustration, in reference to divine subjects, than that to which they are usually confined.

Throughout the whole of the discussions contained in this work, the Author has pursued his own train of thought; and in so doing, he trusts that he has been enabled to render some of his illustrations more interesting to the young and untutored mind, than if he had adhered rigidly to the sentiments of others, and to the technical language of science. The sketches of the different sciences are not mere extracts or compilations, but are, for the most part, original composition—in which it has been his main object to embody as many facts as his limits would permit—in order to excite the inquiring mind to further investigations into the different departments of physical science.

It is presumed, that no Christian reader will for once imagine, that the views illustrated in this work are intended to be *substituted* in place of the peculiar revelations of the Bible. The object of the volume is to illustrate the harmony which subsists between the system of Nature and the system of Revelation; and to show, that the manifestations of God in the material universe ought to be blended with our views of the facts and doctrines recorded in the volume of Inspiration.

It is taken for granted, throughout the whole range of the following illustrations, that the Scriptures contain a Revelation from Heaven; and under a firm belief of this important truth, the Author has embellished his work with frequent quotations from the energetic and sublime language of this Sacred book. It would, therefore, be unfair in any critic, who entertains doubts on this point, to find fault with such quotations, or with the allusions to Bible-phraseology which occur, unless they can be shown to be introduced without judgment or discrimination.

In consequence of the progress of the Arts and Sciences since the Last Edition of the following work was published—the Author has deemed it expedient to make a thorough revision of the whole, so as to embrace the latest improvements and discoveries in the different departments to which its diversified subjects refer. He has accordingly carefully revised every portion of the volume, and made very considerable additions to its several departments. The article GEOLOGY has been almost entirely re-written, and enlarged to more than double its former extent. The article

GEOGRAPHY has been enlarged by an addition of several pages. The articles ASTRONOMY, NATURAL PHILOSOPHY, CHEMISTRY, PHYSIOLOGY, HISTORY, PRINTING, MARINER'S COMPASS, TELESCOPE, AIR BALLOONS, STEAM NAVIGATION, etc., have likewise been considerably enlarged. To the former subjects are now added comprehensive sketches of the following recently-discovered departments of Science and Art—The DAGUERRETYPE, ELECTROTYPE, ELECTRO-MAGNETISM, ELECTRIC TELEGRAPHS, RAILROADS, etc., beside a variety of paragraphs inserted in numerous places throughout the body of the work. Between twenty and thirty additional engravings have been inserted, and to the whole is now added a copious INDEX. These additions amount to more than thirty pages.

This work, in its original form, has had an extensive sale, not only in Great Britain, but also in the United States of America. It is therefore hoped that the improvements and additions which have now been made will render it still more acceptable to the public.

BROUGHTY FERRY, NEAR DUNDEE.

# CONTENTS.

## INTRODUCTION.

	PAGE
Necessity of revelation. Folly of discarding the science of nature from religion. Beneficial effects which flow from the study of the works of God.....	11

## CHAPTER I.

### OF THE NATURAL ATTRIBUTES OF THE DEITY.

#### SECTION I.

##### ON THE RELATION OF THE NATURAL ATTRIBUTES OF THE DEITY TO RELIGION.

The Christian Religion founded on the natural attributes of God. His power as interesting a subject as his mercy, illustrated in two instances. Evils which arise from imperfect conceptions of Divine power. Defects in religious instructions on this subject. Sources of illustration.....	14
---	----

#### SECTION II.

##### ILLUSTRATIONS OF THE OMNIPOTENCE OF THE DEITY.

The material world exhibits a more striking display of this perfection than the supernatural facts recorded in Scripture. <i>Immense quantity of matter in the universe.</i> Mode of acquiring the most comprehensive conception of the bulk of the earth—its variety of scenery—its mass of solid matter. Magnitude of the bodies which compose the solar system. Magnitude and number of the stars. Procedure of the mind in acquiring the most impressive conceptions of such august objects. Reflections. <i>Rapid motions of the celestial bodies.</i> How we acquire the ideas of relative velocities. Weight of the earth. Immense physical forces. Grandeur of the motion of Saturn. Immense number of bodies impelled through the heavens. Reflections. <i>Immense spaces which surround the heavenly bodies.</i> Reflections. Popular illustration of the motions of the earth and heavens. Extract from Dr. Ridgeley, with remarks. Universe intended to <i>adumbrate</i> the attributes of God, and to make a sublime impression on created beings. Similar trains of thought suggested in the Scriptures. <i>Moral effects</i> of such contemplations. <i>Humility</i> —folly of pride—low rank of man in the scale of being. <i>Reverence and veneration.</i> Reason why mankind feel so little veneration of God—how it may be increased. The Deity unsearchable. <i>Hope and confidence</i> in the prospect of futurity—resurrection. Scenes of eternity.....	16
---	----

#### SECTION III.

##### ON THE WISDOM AND INTELLIGENCE OF THE DEITY.

Wisdom defined—displayed in the structure of the solar system. Distance of the sun. Rotation of the planets—principal reason why such a motion exists. Wisdom displayed in other systems. Minute displays of this attribute cannot be traced in the heavens. Wisdom as displayed in the constitution of our globe—adjustment of its solid parts to the necessities of the beings which inhabit it. <i>Mountains</i> —their uses exist in other worlds. Diversity of color—argument for a plurality of worlds—general color which prevails in the scene of nature. <i>Water</i> —its use in the system of nature—its composition—evaporation—motion of the liquid element—its beneficial effects. The <i>atmosphere</i> —its weight and pressure—its component parts—its various properties—necessary to animal life, flame, sound, twilight—wisdom displayed in its constitution. Expansion of water in the act of freezing.....	27
--	----

##### VARIETY OF NATURE.

Vegetables—their number and variety. Animals—variety in their organization. Eyes of insects—their exquisite mechanism. Subterraneous regions. Atmosphere. The variety of	(vii)
--	-------



nature affords a faint idea of the *infinity* of the Creator—illustrated in the number of animal parts and functions. Reflection. Variety of the foundation of our judgments. Beauty and sublimity of nature. Primeval state of our globe. Other worlds..... 33

MECHANISM OF ANIMATED BEINGS. STRUCTURE OF THE HUMAN EYE.

Its coats, humors, muscles, orbit, and motions. Wisdom displayed in its construction. *Light*—its velocity, minuteness, colors, and adaptation to the eye. Manner in which vision is performed—explained by a figure, and an experiment—illustrated by the view from Salisbury Crags. Multitude of rays which flow from every object—smallness of the image on the retina, illustrated by calculation—what proportion of the solar light falls on our globe. Reflections. Mechanism for viewing near and distant objects—contraction and dilatation of the pupil—distance at which we see distinctly. Summary view of adaptations in the structure of the eye. Eyes of superior intelligences. Visual organs of the inferior animals. *Mechanism of the bones* illustrated—exemplified in the joints of the fingers, the wrist, and the movements of which the head is susceptible. Illustration of the horizontal motion of the wrist, and the utility of the human hand, with figures. Moral reflections on the impropriety of overlooking the Divine wisdom in the system of nature..... 37

SECTION IV.

ON THE GOODNESS OR BENEVOLENCE OF THE DEITY.

Benevolence of God in relation to *Man*. What would be the constitution of the world were its Creator a malevolent Being. Benevolence displayed to man, though a depraved intelligence. *Mercy* displayed in the system of nature. Benevolence as displayed toward the lower animals. Extract from Dr. Paley. General reflections..... 46

CHAPTER II.

A CURSORY VIEW OF SOME OF THE SCIENCES WHICH ARE RELATED TO RELIGION AND CHRISTIAN THEOLOGY.

Introduction—extensive range of theology. Bad effects of setting Religion in opposition to Science. Harmony of the operations of God in nature and revelation..... 49

NATURAL HISTORY.

Its extensive range. Outline of its principal objects—on the surface and in the interior recesses of the earth—in the atmosphere—the vegetable, mineral, and animal kingdoms—and in the region of the heavens. Description of the Banian tree. Reflections. Monkey bread tree. Splendor and felicity of insect life. Invisible worlds. Infinity of the universe. *Religious tendency of this science*—it affords a manifestation of the Deity, and expands our conceptions of his operations—ennobles the human mind—recommended by the sacred writers..... 50

GEOGRAPHY.

Its object. Figure of the earth—proofs of its spherical form. Relation which the discovery of the figure of the earth bears to the plan of Providence. How the diameter of the earth enables us to calculate the distances of the heavenly bodies—illustrated with figures. Magnitude and natural divisions of the earth—general features of its surface. *Mountains*—their general ranges, and the sublime scenes they exhibit. The *Ocean*—its extent, depth, bottom, and motions. *Rivers*—their number, size, and the quantity of water they pour into the ocean. How they are supplied—their use in the system of nature. *Artificial* division of the earth. *Europe*—description of its extent, commerce, population, &c. *Asia*—its extent, population, and productions. *Africa*—its divisions, extent, and characteristics. *America*—its dimensions, lakes, rivers, &c. *United States*—their extent, population, literature, &c. *Australasia*—the countries it comprehends. New South Wales, South Australia, &c. Van Dieman's Land, New Zealand, New Guinea, New Britain, &c. Polynesian Islands. *Tahiti*—its characteristics, and the moral improvement of its inhabitants. Sandwich Islands—their improvement. Friendly Islands, Navigator's, Marquesas, New Hebrides. Murder of Williams the Missionary. Number and variety of the earth's inhabitants—number which has existed since the Creation—number at the Resurrection, and the space they would occupy—number which the earth would contain—strictures on Malthus. *Utility of the study of geography to religion*—to directors of Missionary Societies—to private Christians. Works on the subject of Christian Missions characterized and recommended—grandeur of its physical objects—utility of its moral facts..... 56

GEOLOGY.

Its object and connection with religion—an interesting subject of inquiry. Materials which compose the crust of our globe. *Primary rocks*—their constituent materials and general aspect. *Transition rocks*—their formation, &c. *Secondary rocks*, coal formations, &c. *Upper secondary rocks*, and their organic remains. *Tertiary rocks*—their deposits and fossil shells. *Diluvial deposits*. *Alluvial*, and the deltas formed by. *Volcanic rocks*, trap, basalt, Fingal's cave, Giant's causeway, &c. General remarks on organic remains. Various geological phenomena. Periods of organic remains. Description of the Mammoth, Megatherium, &c., with a figure. Conclusions deduced from the facts of geology—their accordance with Sacred History. Genesis, i, 1, explained. High antiquity of the earth not inconsistent with Scripture. Discoveries of astronomy illustrative of geology. Progression a characteristic of the Divine plans, both in the physical and moral world. Date of the present system of our globe. Genesis, i, 2, illustrated. Sublime objects which this science exhibits. . . . . 68

ASTRONOMY.

Its sublime objects. Apparent motions of the sun—of the moon. Eclipses of the sun and moon. Apparent motion of the stary heavens. Position of the Pole-star and Ursa Major, described and represented. Stars and planets seen in the day-time, and with what powers of the telescope they may be distinguished. Apparent revolution of the celestial vault indicates Almighty power. Stars never shift their relative positions. *Solar system*. The *Sun*—his size and probable destination illustrated—his spots and atmosphere—different kinds of rays emitted from his body—his distance illustrated. *Mercury*—his size, rotation, quantity of light and heat, &c. Proportion of caloric on the different planets. *Venus*—her size, phases, mountains, transits, and general phenomena. Original observations on, and mode by which her diurnal rotation may be determined. *Earth*—proofs of its annual and diurnal motions. The *Moon*—description of her majestic mountain scenery, luminous spots, celestial appearances, illuminating power, superficial contents, &c. *Mars*—his distance, atmosphere, luminous zone, &c. *New planets*—Ceres, Pallas, Juno, and Vesta—their anomalies, singularities, and probable origin. Meteoric stones. *Jupiter*—his bulk, rotation, belts, and the appearances of his moons. Telescopic view of his belts and satellites. *Saturn*—his figure, belts, moons, and quantity of light. His *Rings*—their dimensions, motion, and phenomena—illustrated by a figure. Supposed division of his exterior ring. Splendor of the firmament, as viewed from this planet (see the *Frontispiece*). *Herschel*—his distance, size, and quantity of light. *Comets*—their tails, velocity, orbits, size and number. Encke's, Gambart's, and Halley's comets. Motion of the solar system in absolute space—its destination. Plurality of worlds intimated in Scripture. *The fixed stars*—their distance illustrated—arrangement—changes. Moral reflections. Parallax and distance of 61 Cygni. Figure and description of Orion. *Relation of Astronomy to Religion*—moral effects which its objects have a tendency to produce—criminality of overlooking the works of God, &c. . . . . 78

NATURAL PHILOSOPHY.

Its object and different departments. *Mechanics*—subjects it embraces, and its importance to the improvement of mankind. *Hydrostatics*—its leading principles and uses, illustrated by figures. *Pneumatics*—its principles, and the experiments by which they are illustrated. *Acoustics*—various facts in relation to sound. *Optics*—leading facts and principles of this science. Burning glasses, &c. The *Daguerreotype*—description of its nature, processes, and effects. *Electricity*—its nature, phenomena, effects, and agency in the system of nature. *Electrotype*—its invention and practical applications. *Galvanism*—its singular effects on metals, &c., and on the animal system—applied to the blasting of rocks—various facts which it explains. *Magnetism*—its various phenomena and effects. *Electro-Magnetism*—its phenomena and effects. Relation of Natural Philosophy to Religion—its inventions meliorate the condition of mankind—illustrated in the case of the electric fluid—it undermines the influence of superstition—unfolds the incessant agency of God—indifference to this subject unreasonable. . . . . 92

CHEMISTRY.

Its objects, and present dignified station. General forms of matter—simple and compound substances. *Caloric*—its sources and properties. *Oxygen*—its properties and combinations. *Nitrous Oxide*—its singular effects. *Nitrogen*—its effects on flame and animal life. *Hydrogen*—its properties and uses. *Carbon*—its nature, combinations, and antiseptic properties. *Chlorine*—its properties. *Iodine*—its discovery. *Sulphur*—its origin, combinations, and properties. *Phosphorus*—history of its discovery—how prepared—curious experiments with this substance—phosphoric phenomena in the system of nature—connection of this science with religion—it displays the wisdom and benevolence of God, and the mode of his present and future operations—improves the condition of man, and carries forward our views to a more glorious and auspicious era. . . . . 103

ANATOMY AND PHYSIOLOGY.

Their general object. Human body—its different parts and divisions. *Bones*—their number, form, and positions. *Muscles*—their nature, use, and extraordinary strength. *Heart and blood-vessels*, and the circulation of the blood. *Respiration*—curious structure of the lungs. *Digestion. Perspiration. Sensation*, and the system of nerves. Summary. Moral reflections—this branch of study teaches us our dependence on a Superior Power, and excites to gratitude. . . . . 108

HISTORY, ANCIENT AND MODERN.

Its objects, advantages, and connection with religion. Connection of the sciences and of the Divine dispensations with each other. Concluding remarks. . . . . 112

CHAPTER III.

THE RELATION WHICH THE INVENTIONS OF ART BEAR TO THE OBJECTS OF RELIGION.

*Art of Printing*—its origin, and beneficial effects—stereotype and steam printing. . . . . 114  
*Art of Navigation*—mariner's compass—its discovery and use. . . . . 115  
The *Telescope*—its invention, and the discoveries made by it—serves instead of a celestial vehicle. Magnifying powers of Sir W. Herschel's telescopes. Earl of Rosse's speculum. . . . . 117  
The *Microscope*, and views it exhibits of the wisdom of God. . . . . 118  
*Steam Navigation*—its utility in promoting the intercourse of mankind—voyages across the Atlantic—its relation to the objects of religion. . . . . 118  
*Air Balloons*—utility of—when arrived at perfection—proposed improvement in. History of their invention. Lunardi's ascent. The Parachute. Late improvements in, &c. . . . . 119  
*Acoustic Tunnels*. Experiments on the conveyance of sound. M. Biot's remarkable experiments—Don Gautier's experiment and suggestion. Conclusions in reference to the extensive conveyance of sound. . . . . 122  
*Electric Telegraphs*—their nature and applications. . . . . 123  
*Railways*—their history, number, utility, and arrangements. . . . . 124  
Practical remarks—utility of the arts in relation to the Millennial era. . . . . 127

CHAPTER IV.

SCRIPTURAL FACTS ILLUSTRATED FROM THE SYSTEM OF NATURE.

I. Science may frequently serve as a guide to the true interpretation of Scripture. *Canon or rule for Scripture interpretation*—illustrated. . . . . 128  
II. The *Depravity of Man*, illustrated, from a consideration of the state of the interior strata of the earth. Volcanoes, and the terrible ravages they produce. Earthquakes, and their dreadful effects. Thunder-storms, tempests, and hurricanes. General reflections on this subject. . . . . 129  
III. The *Resurrection* illustrated. Transformations of insects. Indestructibility of matter—conclusions from it. . . . . 133  
IV *General Conflagration*. Concluding reflections. *Topics omitted in this volume*. . . . . 134

CHAPTER V.

BENEFICIAL EFFECTS WHICH WOULD RESULT FROM CONNECTING SCIENCE WITH RELIGION.

I. The *variety* of topics would allure the attention of intelligent minds to religious subjects. Principle of novelty intended by the Creator to be gratified—illustrated in the variety which appears in the earth, the heavens, and the Volume of Revelation. . . . . 136  
II. Science enables us to take an *extensive survey of the empire of God*—illustrates many sublime passages of the Bible—qualifies us for complying with several Divine injunctions—danger of selfishness and indifference in this respect. Our conceptions of God depend on our views of the extent of his dominions. . . . . 136  
III. Science enlarges our views of the *operations of Providence*, in relation to the past and present scenes of the world. The economy of the inferior animals. *The physical and moral economy of the celestial world*. . . . . 141  
IV. Science, blended with religion, would produce a general expansion of mind, and liberality of views, in reference to the opinions and actions of men, and to the works and the ways of God, illustrated at large. . . . . 144  
V It would induce a spirit of *piety*, and profound humility. Sources of piety, illustrated by example. Humility—illustrated by the examples of Mr. Boyle, of Sir Isaac Newton, and of superior intelligences. General conclusions. . . . . 146

APPENDIX.

NOTE I. Illustration of the rate of motion in the heavenly bodies, on the supposition that the earth is at rest, 148.—NOTE II. Experimental illustrations of the pressure and compressibility of the atmosphere, the diving-bell, &c., 149.—NOTE III. On the ideas of magnitude, motion, and duration, as expressed by numbers, 150.—NOTE IV. On the means by which it may probably be ascertained whether the moon be a habitable world, 150.—NOTE V. Remarks on the late pretended discovery of a lunar fortification, 151.—NOTE VI. On a plurality of worlds, 151.—NOTE VII. The Daguerreotype, 152.—NOTE VIII. Electro-Magnetic Machines, 152.—NOTE IX. On the first inventor of Printing, 153.—NOTE X. On Telescopes, with a brief notice of a *New Reflecting Telescope*, constructed by the author, 153.—NOTE XI. On Steam Navigation, &c., 154.—NOTE XII. Strictures on a certain sentiment respecting the work of human redemption, 156.—NOTE XIII. Extract from Dr. Dwight's Theology, 157.—NOTE XIV. List of popular works on the different sciences treated of in this volume, with occasional remarks, 157.

THE

# CHRISTIAN PHILOSOPHER.

---

## INTRODUCTION.

ON the subject of RELIGION, mankind have, in all ages, been prone to run into extremes. While some have been disposed to attach too much importance to the mere exertions of the human intellect, and to imagine that man, by the light of unassisted reason, is able to explore the path of true wisdom and happiness,—the greater part of religionists, on the other hand, have been disposed to treat scientific knowledge, in its relation to religion, with a degree of indifference bordering upon contempt. Both these dispositions are equally foolish and preposterous. For he who exalts human reason, as the only sure guide to wisdom and felicity, forgets that man, in his present state, is a *depraved* intelligence, and consequently liable to err; and that all those who have been left solely to its dictates, have uniformly failed in attaining these desirable objects. During a period of more than 5800 years, the greater part of the human race have been left solely to the guidance of their rational powers, in order to grope their way to the Temple of Knowledge, and the Portals of Immortality; but what has been the result of all their anxious researches? Instead of acquiring correct notions of the Great Author of their existence, and of the nature of that homage which is due to his perfections, “they have become vain in their imaginations, and their foolish hearts have been darkened. Professing themselves to be wise, they have become fools; and have changed the glory of the Incorruptible God into an image made like to corruptible man, and to four-footed beasts, and creeping things.” Instead of acquiring correct views of the principles of moral action, and conducting themselves according to the eternal rules of rectitude, they have displayed the operation of the most diabolical passions, indulged in continual warfare, and desolated the earth with rapine and horrid carnage; so that the history of the world presents to our view little more than a series of revolting details of the depravity of our species, and of the wrongs which one tribe of human beings has willfully inflicted upon another.

This has been the case, not only among a few uncultivated hordes on the coast of Africa, in the plains of Tartary, and the wilds of America, but even among those nations which stood highest in the ranks of civilization and of science.—The ancient Greeks and Romans, who boasted of their attainments in philosophy, and their progress in the arts, entertained the most foolish, contradictory, and unworthy notions of the Object of Divine worship, of the requirements of religion, and of the eternal destiny of man. They adored a host of divinities characterized by impiety, fraud, injustice, falsehood, lewdness, treachery, revenge, murder, and every other vice which can debase the human mind, instead of offering a tribute of ra-

tional homage to that Supreme Intelligence who made, and who governs the universe. Even their priests and philosophers indulged in the most degrading and abominable practices, and entertained the most irrational notions in regard to the origin of the universe, and the moral government of the world. Most of them denied a future state of retribution, and all of them had their doubts respecting the reality of an immortal existence; and as to the doctrine of a resurrection from the dead, they never dreamed of such an event, and scouted the idea, when proposed to them, as the climax of absurdity. The glory to which their princes and generals aspired, was, to spread death and destruction among their fellow-men—to carry fire and sword, terror and dismay, and all the engines of destruction, through surrounding nations—to fill their fields with heaps of slain—to plunder the survivors of every earthly comfort, and to drag captive kings at their chariot-wheels—that they might enjoy the splendor and the honors of a triumph. What has been now stated with regard to the most enlightened nations of antiquity, will equally apply to the present inhabitants of China, of Hindostan, of the Japanese Islands, of the Birman empire, and of every other civilized nation on which the light of Revelation has never shone—with this additional consideration, that they have enjoyed an additional period of 1800 years for making further investigations; and are, at this moment, as far from the object of their pursuit as when they first commenced their researches, and not only so, but some of these nations, in modern times, have mingled with their abominable superstitions and idolatries many absurdities and horrid cruelties, which were altogether unknown among the Greek and Roman population.

Such are the melancholy results to which men have been led, when left to the guidance of unassisted reason, in the most interesting and important of all investigations. They have wandered in the mazes of error and delusion; and their researches, instead of directing and expanding our religious views, have tended only to bewilder the human mind, and to throw a deeper shade of intellectual gloom over our apostate world. After a period of six thousand years has been spent in anxious inquiries after the path to true knowledge and happiness—Ignorance, Superstition, Idolatry, Vice, and Misery, still continue to sway the scepter over the great majority of the human race; and if we be allowed to reason from the past to the future, we may rest assured that, while mankind are destitute of a Guide superior to the glimmerings of depraved reason, they would be no nearer the object of their pursuit, after the lapse of *sixty thousand* years, than at the present moment. It is only in connection with the discoveries of Revelation that we can expect that the

efforts of human reason and activity will be successful in abolishing the reign of Ignorance and degrading Superstition—in illuminating the benighted tribes of the Pagan world—and in causing “Righteousness, and Order, and Peace, to spring forth before all the nations.” Though the Christian Religion has never yet been fully understood and recognized, in all its aspects and bearings, nor its requirements been cordially comprehended with, by the great body of those who profess to believe in its divine origin, yet it is only in those nations who have acknowledged its authority, and in some measure submitted to its dictates, that anything approximating to just conceptions of the Supreme Intelligence, and of its moral government, is found to prevail.

But, on the other hand, though the light of nature is of itself a feeble and insufficient guide to direct us in our views of the Supreme Intelligence, and of our eternal destination, yet it is a most dangerous and delusive error to imagine, that reason, and the study of the material world, ought to be discarded from the science of religion. The man who would discard the efforts of the human intellect, and the science of Nature, from Religion, forgets—that He who is the Author of human redemption is also the Creator and Governor of the whole system of the material universe—that it is one end of that moral renovation which the Gospel effects, to qualify us for contemplating aright the displays of Divine Perfection which the works of creation exhibit—that the visible works of God are the principal medium by which he displays the attributes of his nature to intelligent beings—that the study and contemplation of these works employ the faculties of intelligences of a superior order\*—that man, had he remained in primeval innocence, would have been chiefly employed in such contemplations—that it is one main design of Divine Revelation to illustrate the operations of Providence, and the agency of God, in the formation and preservation of all things—and that the Scriptures are full of sublime descriptions of the visible creation, and of interesting references to the various objects which adorn the scenery of Nature. Without the cultivation of our reasoning powers, and an investigation of the laws and economy of Nature, we could not appreciate many of the excellent characters, the interesting aspects, and the sublime references of Revealed religion; we should lose the full evidence of those arguments by which the existence of God, and his attributes of Wisdom and Omnipotence, are most powerfully demonstrated; we should remain destitute of these sublime conceptions of the perfections and agency of Jehovah, which the grandeur and immensity of his works are calculated to inspire; we should never perceive, in its full force, the evidence of those proofs on which the Divine authority of Revelation is founded; we could not give a rational interpretation of the spirit and meaning of many parts of the Sacred Oracles; nor could we comply with those positive commands of God, which enjoin us to contemplate the wonders of his power, “to meditate on all his works, and to talk of all his doings.”

Notwithstanding these and many other considerations, which show the folly of overlooking the visible manifestations of Deity in the exercises of Religion, it has long been the practice of certain theologians to depreciate the wonderful works of Jehovah, and to attempt to throw them into the shade, as if they were unworthy of our serious

contemplation. In their view, to be a bad philosopher is the surest way to become a good Christian, and to expand the views of the human mind is to endanger Christianity, and to render the design of religion abortive. They seem to consider it as a most noble triumph to the Christian cause, to degrade the material world, and to trample under foot not only the earth, but the visible heavens, as an old, shattered, and corrupted fabric, which no longer demands our study or admiration. Their expressions, in a variety of instances, would lead us almost to conclude, that they considered the economy of Nature as set in opposition to the economy of Redemption, and that it is not the same God that contrived the system of Nature who is also the “Author of eternal salvation to all them that obey him.”

It is, unquestionably, both foolish and impious to overlook or to undervalue any of the modes by which the Divine Being has been pleased to make known his nature and perfections to mankind. Since he has given a display of his “Eternal power and Godhead” in the grand theater of nature, which forms the subject of scientific investigation, it was surely never intended, and would ill comport with reverence for its adorable Author, that such magnificent displays of his Power, Wisdom, and Beneficence, as the material universe exhibits, should be treated, by his intelligent offspring, with indifference or neglect. It becomes us to contemplate, with adoring gratitude every ray of our Creator’s glory, whether as emanating from the light of Revelation, or as reflected from the scenery of nature around us, or a descending from those regions where stars unnumbered shine, and planets and comets run their solemn rounds. Instead of contrasting the our department of knowledge with the other, with a view of depreciating the science of nature, our duty is, to derive from both as much information and instruction as they are calculated to afford to mark the harmony of the revelations they respectively unfold; and to use the revelations of nature for the purpose of confirming, and amplifying, and carrying forward our views of the revelation contained in the Sacred Scriptures.

With regard to the revelation derived from the Sacred Records, it has been imagined by some that it has little or no reference to the operations of the material system, and that, therefore, the study of the visible works of God can be of little importance in promoting religious knowledge and holy affections. In the sequel of this volume, I shall endeavor to show, that this sentiment is extremely fallacious, and destitute of a foundation. But, in the meantime, although it were taken for granted, it would form no argument against the combination of science with religion. For I ought to be carefully remarked, that Divine Revelation is chiefly intended to instruct us in the knowledge of those truths which interest us as subjects of the *moral administration* of the Governor of the world,—or, in other words, as apostate creatures, and as moral agents. Its grand object is to develop the openings and bearings of the plan of Divine Mercy; to counteract those evil propensities and passions which sin has introduced; to inculcate those holy principles and moral laws which tend to unite mankind in harmony and love; and to produce those amiable tempers and dispositions of mind which alone can fit us for enjoying happiness, either in this world or in the world to come. For this reason, doubtless, it is, that the *moral* attributes of Deity are brought more prominently into view, in the Sacred Volume, than his *natural* perfections; and that those

\* Rev. iv. 11; xv. 3, etc.



special arrangements of his Providence, which regard the *moral* renovation of our species, are particularly detailed; while the immense extent of his universal kingdom, the existence of other worlds, and their moral economy, are but slightly hinted at, or veiled in obscurity. Of such a Revelation we stood in need; and had it chiefly embraced subjects of a very different nature, it would have failed in supplying the remedies requisite for correcting the disorders which sin has introduced among mankind.—But surely it was never intended, even in a religious point of view, that the powers of the human mind, in their contemplations and researches, should be bounded by the range of subjects comprised in that revelation which is purely or chiefly of a *moral* nature; since the Almighty has exhibited so magnificent a spectacle in the universe around us, and endowed us with faculties adequate to the survey of a considerable portion of its structure, and capable of deducing from it the most noble and sublime results. To walk in the midst of this “wide-extended theater,” and to overlook, or to gaze with indifference on those striking marks of Divine Omnipotence and skill which everywhere appear, is to overlook the Creator himself, and to contemn the most illustrious displays he has given of his eternal power and glory. That man’s religious devotions are much to be suspected, whatever show of piety he may affect, who derives no assistance, in attempting to form some adequate conceptions of the object of his worship, from the sublime discoveries of astronomical science; from those myriads of suns and systems which form but a small portion of the Creator’s immense empire!\* The professing Christian, whose devotional exercises are not invigorated, and whose conceptions of Deity are not expanded, by a contemplation of the magnitude and variety of his works, may be considered as equally a stranger to the more elevated strains of piety, and to the noble emotions excited by a perception of the beautiful and the sublime.

“The works of the Lord,” says an inspired writer, “are *great*, and are sought out by all those who have pleasure therein.” They all bear the stamp of Infinite Perfection, and serve as so many sensible mediums to exalt and expand our conceptions of Him whose invisible glories they represent and adumbrate. When contemplated in connection with the prospects opened by Divine Revelation, they tend to excite the most ardent

desires after that state of enlarged vision, where the plans and operations of Deity will be more clearly unfolded—and to prepare us for bearing a part in the immortal hymn of the Church triumphant:—“Great and marvelous are thy works, Lord God Almighty; just and true are thy ways, thou King of saints.” The most illustrious characters that have adorned our race in all ages, have been struck with the beauty and magnificence of the visible creation, and have devoted a certain portion of their time and attention in investigating its admirable economy and arrangement; and there can be no question, that a portion of our thoughts devoted to the study of the wondrous works of the Most High, must ultimately be conducive to the improvement of our intellectual powers, to our advancement in the Christian life, and to our preparation for the exalted employments of the eternal world.

In fine, since the researches of modern times have greatly enlarged our views of the System of Universal Nature, and of the vast extent to which the operations of the Creator are carried on in the distant regions of space,—since the late discoveries of Naturalists and Experimental Philosophers, with respect to the constitution of the atmosphere, water, light, heat, the gases, the electric, galvanic, and magnetic fluids, and the economy and instincts of animated beings, have opened to our view a bright display of Divine Wisdom, in the contrivance and arrangement of the different parts of our terrestrial habitation,—since improvements in the useful arts have kept pace with the progress of science, and have been applied to many beneficial purposes, which have ultimately a bearing on the interests and the progress of religion,—since a general desire to propagate the truths of Christianity in heathen lands now animates the mass of the religious world,—since the nations of both Continents are now aroused to burst asunder the shackles of despotism, and to inquire after rational liberty and mental improvement,—and since all these discoveries, inventions, and movements, and the energies of the human mind, from which they spring, are under the control and direction of that Omnipotent Being who made and who governs the world,—they ought to be considered as parts of those providential arrangements, in the progress of which He will ultimately accomplish the illumination of our benighted race, and make the cause of righteousness and truth to triumph among all nations. And, therefore, the enlightened Christian ought thankfully to appreciate every exhibition, and every discovery, by which his conceptions of the attributes of God, and of the grandeur of his works, may be directed and enlarged, in order that he may be qualified to “speak of the honor of his majesty, and talk of his power; to make known to the sons of men his mighty acts, and the glorious majesty of his kingdom.”

\* As some readers seem to have mistaken the Author’s meaning in this and similar passages, it may be proper to state, that his meaning is not—that a knowledge of natural science is *essential* to genuine piety; but, that the person who has an opportunity of making himself acquainted with the science of nature, and of contemplating the wonders of the heavens in their true light, and who does not find his views of the Creator expanded, and his religious emotions elevated, by such studies, has reason to call in question the nature and the sincerity of his devotional feelings.

## CHAPTER I.

### OF THE NATURAL ATTRIBUTES OF THE DEITY, WITH PARTICULAR ILLUSTRATIONS OF HIS OMNIPOTENCE AND WISDOM.

#### SECTION I.

##### ON THE RELATION OF THE NATURAL ATTRIBUTES OF DEITY TO RELIGION.

A FIRM conviction of the existence of God, and a competent knowledge of his natural perfections, lie at the foundation of all religion, both natural and revealed. In proportion as our views of the perfections of Deity are limited and obscure, in a similar proportion will be our conceptions of all the relations in which he stands to his creatures, of every part of his providential procedure, and of all the doctrines and requirements of revealed religion.

By the natural or essential attributes of God, we understand such perfections as the following:—His Eternity, Omnipresence, Infinite Knowledge, Infinite Wisdom, Omnipotence, and Boundless Beneficence. These are the characters and attributes of Deity, which, we must suppose, form the chief subjects of contemplation to angels, and to all other pure intelligences—and, in investigating the displays of which, the sons of Adam would have been chiefly employed, had they continued in primal innocence. These attributes form the groundwork of all those gracious relations in which the God of salvation stands to his redeemed people in the economy of redemption—they lie at the foundation of the whole Christian superstructure—and were they not recognized as the corner stones of that sacred edifice, the whole system of the Scripture Revelation would remain a baseless fabric. The full display of these perfections will be exhibited in the future world—the contemplation of this display will form one of the sublime employments “of the saints in light”—and to prepare us for engaging in such noble exercises, is one of the chief designs of the salvation proclaimed in the Gospel.

The Christian Revelation ought not to be considered as superseding the Religion of Nature, but as carrying it forward to perfection. It introduces the Deity to us under *new* relations corresponding to the degraded state into which we have fallen. It is superadded to our natural relations to God, and takes it for granted that these natural relations must forever subsist. It is true, indeed, that the essential attributes of God, and the principles of Natural Religion, cannot be fully discovered without the light of Revelation, as appears from the past experience of mankind in every generation; but it is equally true, that, when discovered by the aid of this celestial light, they are of the utmost importance in the Christian system, and are as essentially connected with it as the foundation of a building is with the superstructure. Many professed Christians, however, seem to think and to act as if the Christian Revelation had annulled the natural relations which subsist between man and the Deity; and

hence the zealous outcry against every discussion from the pulpit, that has not a *direct* relation to what are termed the doctrines of grace. But nothing surely can be more absurd than to carry out such a principle to all its legitimate consequences. Can God ever cease to be Omnipotent, or can man ever cease to be dependent for existence on his infinite power? Can the Divine Being ever cease to be Omnipresent and Omniscient, or can man ever cease to be the object of his knowledge and superintendence? Can Infinite Wisdom ever be detached from the Almighty, or can man ever be in a situation where he will not experience the effects of his wise arrangements? Can Goodness ever fail of being an attribute of Jehovah, or can any sentient or intelligent beings exist that do not experience the effects of his bounty? Can Divine Benevolence ever cease in its operations, throughout any period of future duration, or can any intelligent beings exist, throughout any department of creation, who shall not, in a greater or less degree, experience its effects? In short, can the relation of  *Creature and Creator* ever cease between the human race in whatever moral or physical situation they may be placed, and that Almighty Being “who giveth to all life and breath and all things?” If none of these things can possibly happen, then the relations to which we refer must be eternal and unchangeable, and must form the basis of all the other relations in which we can possibly stand to the Divine Being, either as apostate or as redeemed creatures; and, therefore, they ought to be exhibited as subjects for our frequent and serious contemplation, as religious and moral agents. But, unless we make such topics a distinct subject of attention, and endeavor to acquire clear and comprehensive conceptions of our natural relations to God, we can never form a clear conception of those new and interesting relations into which we have been brought by the mediation of Jesus Christ.

If man had continued in his primitive state of integrity, he would have been forever exercised in tracing the Power, the Beneficence, and other attributes of Deity, in the visible creation alone. Now that his fallen state has rendered additional revelations necessary, in order to secure his happiness,—is he completely to throw aside those contemplations and exercises which constituted his chief employment while he remained a pure moral intelligence? Surely not. One great end of his moral renovation, by means of the Gospel, must be to enable him to *resume his primitive exercises*, and to qualify him for more enlarged views and contemplations of a similar nature, in that future world, where the physical and moral impediments which now obstruct his progress will be completely removed.

It appears highly unreasonable, and indicates a selfish disposition of mind, to magnify one class of the Divine attributes at the expense of another;

to extol, for example, the Mercy of God, and neglect to celebrate his Power and Wisdom—those glorious perfections, the display of which, at the formation of our globe, excited the rapture and admiration of angels, and of innocent man. All the attributes of God are *equal*, because all of them are *infinite*; and therefore to talk of *darling* attributes in the Divine Nature, as some have done, is inconsistent with reason, unwarranted by Scripture, and tends to exhibit a distorted view of the Divine character. The Divine Mercy ought to be celebrated with rapture by every individual of our fallen race; but with no less rapture should we extol the Divine Omnipotence; for the designs of Mercy cannot be accomplished without the intervention of infinite Power. Even the attribute of *Justice*—which is frequently viewed with emotions of terror—is nothing else than a branch of the Divine Benevolence, for preventing the inroads of anarchy and confusion and for securing the order and happiness of the intelligent creation. All that we hope for, in consequence of the promises of God, and of the redemption accomplished by Jesus Christ, must be founded on the conception we form of the operations of Omnipotence. An example or two may not be unnecessary for illustrating this position.

We are warranted by the Sacred Oracles, to entertain the hope that these mortal bodies of ours, after they have moldered in the dust, been dissolved into their primary elementary parts, and become the prey of devouring reptiles, during a lapse of generations or centuries—shall spring forth from the tomb to new life and beauty, and be arrayed in more glorious forms than they now wear; yea, that all the inhabitants of our globe, from Adam to the end of time, though the bodies of thousands of them have been devoured by annibals, have become the food of fishes and of beasts of prey, and have been burned to cinders, and their ashes scattered by the winds, over the different regions of sea and land—shall be reanimated by the voice of the Son of God, and shall appear, each in his own proper person and identical body, before God the Judge of all. Now, the firmness of our hope of so astonishing an event, which seems to contradict all experience, and appears involved in such a mass of difficulties and apparent contradictions, must be in proportion to the sentiments we entertain of the Divine Intelligence, Wisdom, and Omnipotence. And where are we to find the most striking visible displays of these perfections, except in the actual operations of the Creator, within the range of our view in the material world?

Again, we are informed in the same Divine records, that, at some future period, the earth on which we now dwell shall be wrapt up in devouring flames, and its present form and constitution forever destroyed; that its redeemed inhabitants, after being released from the grave, shall be transported to a more glorious region; and that “new heavens and a new earth shall appear, wherein dwelleth righteousness.” The Divine mercy having given to the faithful the promise of these astonishing revolutions, and most magnificent events, our hopes of their being fully realized must rest on the infinite wisdom and omnipotence of Jehovah; and consequently, if our views of these perfections be limited and obscure, our hope, in relation to our future destiny, will be proportionably feeble and languid; and will scarcely perform its office “as an anchor to the soul, both sure and steadfast.” It is not merely by telling a person that God is all-wise and all-powerful, that a full conviction of the accomplish-

ment of such grand events will be produced. He must be made to see with his own eyes what the Almighty *has already done*, and what he is now doing, in all the regions of universal nature which lie open to our inspection; and this cannot be effected without directing his contemplations to those displays of intelligence and power which are exhibited in the structure, the economy, and the revolutions of the material world.

If the propriety of these sentiments be admitted, it will follow, that the more we are accustomed to contemplate the wonders of Divine intelligence and power, in the objects with which we are surrounded, the more deeply shall we be impressed with a conviction and a confident hope, that all the purposes of Divine mercy will ultimately be accomplished in our eternal felicity. It will also follow, that, in proportion as the mind acquires a clear, an extensive, and a reverential view of the essential attributes of the Deity, and of those truths in connection with them which are objects of contemplation common to all holy beings, in a similar proportion will it be impressed, and its attention arrested, by every other Divine subject connected with them. And it is, doubtless, owing to the want of such clear and impressive conceptions of the essential character of Jehovah, and of the first truths of religion, that the bulk of mankind are so little impressed and influenced by the leading doctrines and duties connected with the plan of the Gospel salvation, and that they entertain so many vague and untenable notions respecting the character and the objects of a superintending Providence. How often, for example, have we witnessed expressions of the foolish and limited notions which are frequently entertained respecting the operations of Omnipotence! When it has been asserted that the earth, with its load of continents and oceans, is in rapid motion through the voids of space—that the sun is ten hundred thousand times larger than the terraqueous globe—and that millions of such globes are dispersed throughout the immensity of nature,—some who have viewed themselves as enlightened Christians, have exclaimed at the impossibility of such facts, as if they were beyond the limits of Divine Power, and as if such representations were intended to turn away the mind from God and religion; while, at the same time, they have yielded a firm assent to all the vulgar notions respecting omens, apparitions, and hobgoblins, and to the supposed extraordinary powers of the professors of divination and witchcraft. How can such persons assent, with intelligence and rational conviction, to the dictates of Revelation respecting the energies of Omnipotence which will be exerted at “the consummation of all things,” and in those arrangements which are to succeed the dissolution of our sublunary system! A firm belief in the Almighty Power and unsearchable Wisdom of God, as displayed in the constitution and movements of the material world, is of the utmost importance, to confirm our faith and enliven our hopes of such grand and interesting events.

Notwithstanding the considerations now stated, which plainly evince the connection of the natural perfections of God with the objects of the Christian Revelation, it appears somewhat strange that, when certain religious instructors happen to come in contact with this topic, they seem as if they were beginning to tread upon forbidden ground; and as if it were unsuitable to their office as Christian teachers, to bring forward the stupendous works of the Almighty to illustrate his nature and attributes. Instead of expatiating on the numerous sources of illustration of which

the subject admits, until the minds of their hearers are thoroughly affected with a view of the essential glory of Jehovah—they dispatch the subject with two or three vague propositions, which, though logically true, make no impression upon the heart; as if they believed that such contemplations were suited only to carnal men and mere philosophers; and as if they were afraid lest the sanctity of the pulpit should be polluted by particular descriptions of those operations of the Deity which are perceived through the medium of the corporeal senses. We do not mean to insinuate that the essential attributes of God, and the illustrations of them derived from the material world, should form the sole or the chief topics of discussion in the business of religious instruction; but, if the Scriptures frequently direct our attention to these subjects—if they lie at the foundation of all accurate and extensive views of the Christian Revelation—if they be the chief subjects of contemplation to angels and all other pure intelligences, in every region of the universe—and if they have a tendency to expand the minds of professed Christians, to correct their vague and erroneous conceptions, and to promote their conformity to the moral character of God—we cannot find out the shadow of a reason why such topics should be almost, if not altogether overlooked, in the writings and the discourses of those who profess to instruct mankind in the knowledge of God and the duties of his worship.

We are informed by our Saviour himself, that "this is life eternal, to know thee the living and true God," as well as "Jesus Christ whom he hath sent." The knowledge of God in the sense here intended, must include in it the knowledge of the natural and essential attributes of the Deity, or those properties of his nature by which he is distinguished from "all the idols of the nations." Such are, his Self-existence, his All-perfect Knowledge, his Omnipresence, his Infinite Wisdom, his Boundless Goodness and Almighty Power—attributes which, as we have just now seen, lie at the foundation of all the other characters and relations of Deity revealed in the Scriptures. The acquisition of just and comprehensive conceptions of those perfections must therefore lie at the foundation of all profound veneration of the Divine Being, and of all that is valuable in religion. Destitute of such conceptions, we can neither feel that habitual *humility*, and that *reverence* of the majesty of Jehovah, which his essential glory is calculated to inspire, nor pay him that tribute of adoration and gratitude which is due to his name. Devoid of such views, we cannot exercise that cordial acquiescence in the plan of his redemption, in the arrangements of his providence, and in the requirements of his law, which the Scriptures enjoin. Yet, how often do we find persons who pretend to speculate about the mysteries of the Gospel—displaying by their flippancy of speech respecting the eternal counsels of the Majesty of heaven—by their dogmatical assertions respecting the Divine character, and the dispensations of providence—and by their pertinacious opinions respecting the laws by which God *must* regulate his own actions—that they have never felt impressive emotions of the grandeur of that Being whose "operations are unsearchable, and his ways past finding out!" Though they do not call in question his immensity and power, his wisdom and goodness, as so many abstract properties of his nature, yet, the unbecoming familiarity with which they approach this August Being, and talk about him, shows that they have never associated in their minds the

stupendous displays which have been given of these perfections, in the works of his hands; and that their religion (if it may be so called) consists merely in a farrago of abstract opinions, or in an empty name.

If, then, it be admitted, that it is essentially requisite, as the foundation of religion, to have the mind deeply impressed with a clear and comprehensive view of the natural perfections of the Deity, it will follow that the ministers of religion, and all others whose province it is to communicate religious instruction, ought frequently to dwell with particularity on those proofs and illustrations which tend to convey the most definite and impressive conceptions of the glory of that Being whom we profess to adore. But from what sources are such illustrations to be derived? Is it from abstract reasonings and metaphysical distinctions and definitions, or from a survey of those objects and movements which lie open to the inspection of every observer? There can be no difficulty in coming to a decision on this point. We might affirm, with the schoolmen, that "God is a Being whose center is everywhere, and his circumference nowhere;" that "he comprehends infinite duration in every moment;" and that "infinite space may be considered as the *sensorium* of the Godhead;" but such fanciful illustrations, when strictly analyzed, will be found to consist merely of *words* without *ideas*. We might also affirm, with truth, that God is a Being of infinite perfection, glory, and blessedness—that he is without all bounds or limits, either actual or possible—that he is possessed of power sufficient to perform all things which do not imply a contradiction—that he is independent and self-sufficient—that his wisdom is unerring, and that he infinitely exceeds all other beings. But these, and other expressions of a similar kind, are mere *technical terms*, which convey no adequate, nor even tolerable notion of what they import. Beings, constituted like man, whose rational spirits are connected with an organical structure, and who derive all their knowledge through the medium of corporeal organs, can derive their clearest and most affecting notions of the Divinity chiefly through the same medium; namely, by contemplating the *effects* of his perfections, as displayed through the ample range of the visible creation. And to this source of illustration, the inspired writers uniformly direct our views—"Lift up your eyes on high, and behold! who hath created these orbs? who bringeth forth their host by number, and calleth them all by their names? The everlasting God, the Lord, by the greatness of his might, for that he is strong in power;"—"He hath made the earth by his power; he hath established the world by his wisdom; he hath stretched out the heavens by his understanding."—These writers do not perplex our minds by a multitude of technical terms and subtle reasonings; but lead us directly to the source whence our most ample conceptions of Deity are to be derived, that, from a steady and enlightened contemplation of the effects, we may learn the greatness of the Cause; and their example in this respect ought, doubtless, to be a pattern for every religious instructor.

## SECTION II.

### ILLUSTRATIONS OF THE OMNIPOTENCE OF THE DEITY.

In order to elucidate more distinctly what has been now stated, I shall select a few illustrations

of some of the natural attributes of the Deity. And, in the first place, I shall offer a few considerations which have a tendency to direct and to amplify our conceptions of Divine Power.

Omnipotence is that attribute of the Divine Being, by which he can accomplish everything that does not imply a contradiction—however far it may transcend the comprehension of finite minds. By his power the vast system of universal nature was called from nothing into existence, and is continually supported in all its movements, from age to age.—In elucidating this perfection of God, we might derive some striking illustrations from the records of his dispensations toward man, in the early ages of the world—When he overwhelmed the earth with a deluge, which covered the tops of the highest mountains, and swept the crowded population of the ancient world into a watery grave—when he demolished Sodom and Gomorrah, and the cities around them, with fire from heaven—when he slew all the first-born of Egypt, and turned their rivers into blood—when he divided the Red sea and the waters of Jordan, before the tribes of Israel—when he made the earth open its jaws and swallow up Korah and all his company—and when he caused mount Sinai to smoke and tremble at his presence. But these and similar events, however awful, astonishing, and worthy of remembrance, were only *transitory* exertions of Divine power, and are not calculated, and were never intended, to impress the mind in so powerful a manner as those displays of Omnipotence which are exhibited in the ordinary movements of the material universe. We have no hesitation in asserting, that, with regard to this attribute of the Divinity, there is a more grand and impressive display in the Works of Nature than in all the events recorded in the Sacred History. Nor ought this remark to be considered as throwing the least reflection on the fullness and sufficiency of the Scripture Revelation; for that revelation, as having a special reference to a *moral* economy, has for its object, to give a more particular display of the *moral* than of the *natural* perfections of God. The miracles to which we have now referred, and every other supernatural fact recorded in the Bible, were not intended so much to display the *plenitude* of the power of the Deity, as to bear testimony to the Divine mission of particular messengers, and to confirm the truths they declared. It was not, for example, merely to display the energies of Almighty power, that the waters of the Red sea were dried up before the thousands of Israel, but to give a solemn and striking attestation to all concerned, that the Most High God had taken this people under his peculiar protection—that he had appointed Moses as their leader and legislator—and that they were bound to receive and obey the statutes he delivered. The most appropriate and impressive illustrations of Omnipotence are those which are taken from the *permanent* operations of Deity, which are visible every moment in the universe around us; or, in other words, those which are derived from the facts which have been observed in the material world, respecting *magnitude* and *motion*.

In the first place, *the immense quantity of matter* contained in the universe, presents a most striking display of Almighty power.

In endeavoring to form a definite notion on this subject, the mind is bewildered in its conceptions, and is at a loss where to begin or to end its excursions. In order to form something approximating to a well-defined idea, we must pursue a

train of thought commencing with those magnitudes which the mind can easily grasp, proceeding through all the higher gradations of magnitude, and fixing the attention on every portion of the chain, until we arrive at the object or magnitude of which we wish to form a conception. We must endeavor, in the first place, to form a conception of the bulk of the world in which we dwell, which, though only a point in comparison of the whole material universe, is in reality, a most astonishing magnitude, which the mind cannot grasp without a laborious effort. We can form some definite idea of those protuberant masses we denominate *hills*, which rise above the surface of our plains; but were we transported to the mountainous scenery of Switzerland, to the stupendous range of the Andes in South America, or to the Himalayan mountains in India, where masses of earth and rocks, in every variety of shape, extend several hundreds of miles in different directions, and rear their projecting summits beyond the region of the clouds—we should find some difficulty in forming an adequate conception of the objects of our contemplation. For (to use the words of one who had been a spectator of such scenes), “Amidst those trackless regions of intense silence and solitude, we cannot contemplate, but with feelings of awe and admiration, the enormous masses of variegated matter which lie around, beneath, and above us. The mind labors, as it were, to form a definite idea of those objects of oppressive grandeur, and feels unable to grasp the august objects which compose the surrounding scene.” But what are all these mountainous masses, however variegated and sublime, when compared with the bulk of the whole earth? Were they hurled from their bases, and precipitated into the vast Pacific ocean, they would all disappear in a moment, except perhaps a few projecting tops, which, like a number of small islands, might be seen rising a few fathoms above the surface of the waters.

The earth is a globe, whose diameter is nearly 8000 miles, and its circumference about 25,000, and consequently, its surface contains nearly two hundred millions of square miles—a magnitude too great for the mind to take in at *one* conception. In order to form a tolerable conception of the whole, we must endeavor to take a leisurely survey of its different parts. Were we to take our station on the top of a mountain, of a moderate size, and survey the surrounding landscape, we should perceive an extent of view stretching 40 miles in every direction, forming a circle 80 miles in diameter, and 250 in circumference, and comprehending an area of 5000 square miles. In such a situation, the terrestrial scene around and beneath us—consisting of hills and plains, towns and villages, rivers and lakes—would form one of the largest objects which the eye, or even the imagination, can steadily grasp at one time. But such an object, grand and extensive as it is, forms no more than the *forty thousandth part* of the terraqueous globe; so that, before we can acquire an adequate conception of the magnitude of our own world, we must conceive 40,000 landscapes, of a similar extent, to pass in review before us; and, were a scene, of the magnitude now stated, to pass before us every hour, until all the diversified scenery of the earth were brought under our view, and were twelve hours a-day allotted for the observation, it would require nine years and forty-eight days before the whole surface of the globe could be contemplated, even in this *general* and *rapid* manner. But, such a variety of successive landscapes

passing before the eye, even although it were possible to be realized, would convey only a very vague and imperfect conception of the scenery of our world; for objects at the distance of forty miles cannot be distinctly perceived; the only view which would be satisfactory would be that which is comprehended within the range of three or four miles from the spectator.

Again, I have already stated, that the surface of the earth contains nearly 200,000,000 of square miles.—Now, were a person to set out on a minute survey of the terraqueous globe, and to travel until he passed along every square mile on its surface, and to continue his route without intermission, at the rate of 30 miles every day, it would require 18,264 years before he could finish his tour, and complete the survey of "this huge rotundity on which we tread:" so that, had he commenced his excursion on the day on which Adam was created, and continued it to the present hour, he would not have accomplished one-third part of this vast tour.

In estimating the size and extent of the earth, we ought also to take into consideration, the vast variety of objects with which it is diversified, and the numerous animated beings with which it is stored;—the great divisions of land and water, the continents, seas, and islands, into which it is distributed; the lofty ranges of mountains which rear their heads to the clouds; the unfathomable abysses of the ocean; its vast subterranean caverns and burning mountains; and the lakes, rivers, and stately forests, with which it is so magnificently adorned;—the many millions of animals, of every size and form, from the elephant to the mite, which traverse its surface; the numerous tribes of fishes, from the enormous whale to the diminutive shrimp, which "play" in the mighty ocean; the aerial tribes which sport in the regions above us, and the vast mass of the surrounding atmosphere, which encloses the earth and all its inhabitants, as "with a swaddling band." The immense variety of beings with which our terrestrial habitation is furnished, conspires, with every other consideration, to exalt our conceptions of that Power by which our globe, and all that it contains, were brought into existence.

The preceding illustrations, however, exhibit the vast extent of the earth, considered only as a mere superficies. But we know that the earth is a solid globe, whose specific gravity is nearly five times denser than water, or about twice as dense as the mass of earth and rocks which compose its surface. Though we cannot dig into its bowels beyond a mile in perpendicular depth, to explore its hidden wonders, yet we may easily conceive what a vast and indescribable mass of matter must be contained between the two opposite portions of its external circumference, reaching 8000 miles in every direction. The solid contents of this ponderous ball is no less than 263,858,149,120 cubical miles—a mass of material substance of which we can form but a very faint and imperfect conception: in proportion to which, all the lofty mountains which rise above its surface, are less than a few grains of sand, when compared with the largest artificial globe. Were the earth a hollow sphere, surrounded merely with an external shell of earth and water ten miles thick, its internal cavity would be sufficient to contain a quantity of materials *one hundred and thirty-three times* greater than the whole mass of continents, islands, and oceans, on its surface, and the foundations on which they are supported. We have the strongest reasons, however, to conclude, that the earth, in its general structure, is one solid mass, from the

surface to the center, excepting, perhaps, a few caverns scattered here and there amidst its subterranean recesses; and that its density gradually increases from its surface to its central regions. What an enormous mass of materials, then, is comprehended within the limits of the globe on which we tread! The mind labors, as it were, to comprehend the mighty idea, and, after all its exertion, feels itself unable to take in such an astonishing magnitude at *one* comprehensive grasp! How great must be the power of that Being who commanded it to spring from nothing into existence, who "measures the ocean in the hollow of his hand, who weigheth the mountains in scales, and hangeth the earth upon nothing!"

It is essentially requisite, before proceeding to the survey of objects and magnitudes of a superior order, that we should endeavor, by such a train of thought as the preceding, to form some tolerable and clear conception of the bulk of the globe we inhabit; for it is the only body we can use as a standard of comparison to guide the mind in its conceptions, when it roams abroad to other regions of material existence. And from what has been now stated, it appears, that we have *no adequate* conception of a magnitude of so vast an extent; or at least, that the mind cannot, in any one instant, form to itself a distinct and comprehensive idea of it, in any measure corresponding to the reality.

Hitherto, then, we have fixed only on a determinate magnitude—on a scale of a few inches, as it were, in order to assist us in our measurement and conception of magnitudes still more august and astonishing. When we contemplate by the light of science, those magnificent globes which float around us in the concave of the sky, the earth, with all its sublime scenery, stupendous as it is, dwindles into an inconsiderable ball. If we pass from our globe to some of the other bodies of the planetary system, we shall find that one of these stupendous orbs is more than 900 times the size of our world, and encircled with a ring 200,000 miles in diameter, which would nearly reach from the earth to the moon, and would enclose within its vast circumference several hundreds of worlds as large as ours. Another of these planetary bodies, which appears to the vulgar eye only as a brilliant speck on the vault of heaven, is found to be of such a size, that it would require 1400 globes of the bulk of the earth to form one equal to it in dimensions. The whole of the bodies which compose the solar system (without taking the sun and the comets into account) contain a mass of matter 2500 times greater than that of the earth. The sun itself is 590 times larger than all the planetary globes taken together; and one million three hundred thousand times larger than the terraqueous globe. This is one of the most glorious and magnificent visible objects which either the eye or the imagination can contemplate; especially when we consider, what perpetual, and incomprehensible, and powerful influence it exerts—what warmth, and beauty, and activity it diffuses, not only on the globe we inhabit, but over the more extensive regions of surrounding worlds. Its energy extends to the utmost limits of the planetary system—to the planet Herschel which revolves at the distance of 1500 millions of miles from its surface, and there it dispenses light, and color, and comfort, to all the beings connected with that far distant orb, and to all the moons which roll around it.

Here the imagination begins to be overpowered and bewildered in its conceptions of magnitude, when it has advanced scarcely a single step in its

excursions through the material world. For it is highly probable, that all the matter contained within the limits of the solar system, incomprehensible as its magnitude appears, bears a smaller proportion to the whole mass of the material universe, than a single grain of sand to all the particles of matter contained in the body of the sun and his attending planets.

If we extend our views from the solar system to the starry heavens, we have to penetrate, in our imagination, a space which the swiftest ball that was ever projected, though in perpetual motion, would not traverse in ten hundred thousand years. In those trackless regions of immensity, we behold an assemblage of resplendent globes, similar to the sun in size and in glory, and doubtless accompanied with a retinue of worlds, revolving like our own around their attractive influence. The immense distance at which the nearest stars are known to be placed proves that they are bodies of a prodigious size, not inferior to our own sun, and that they shine not by reflected rays, but by their own native light. But bodies encircled with such refulgent splendor would be of little use in the economy of Jehovah's empire, unless surrounding worlds were cheered by their benign influence, and enlightened by their beams. Every star is, therefore, with good reason, concluded to be a sun, no less spacious than ours, surrounded by a host of planetary globes, which revolve around it as a center, and derive from it light and heat and comfort. Nearly a thousand of these luminaries may be seen in a clear winter night by the naked eye; so that a mass of matter equal to a thousand solar systems, or to *thirteen hundred and twenty millions of globes of the size of the earth*, may be perceived by every common observer in the canopy of heaven. But all the celestial orbs which are perceived by the unassisted sight do not form the eighty thousandth part of those which may be described by the help of optical instruments. The telescope has enabled us to descry in certain spaces in the heavens, thousands of stars where the naked eye could scarcely discern twenty. The late celebrated astronomer, Dr. Herschel, has informed us, that in the most crowded parts of the Milky-way, when exploring that region with his best glasses, he has had fields of view which contained no less than 588 stars, and these were continued for many minutes; so that "in one quarter of an hour's time there passed no less than *one hundred and sixteen thousand stars* through the field of view of his telescope."

It has been computed, that nearly *one hundred millions* of stars might be perceived by the most perfect instruments, were all the regions of the sky thoroughly explored; and yet, all this vast assemblage of suns and worlds, when compared with what lies beyond the utmost boundaries of human vision, in the immeasurable spaces of creation, may be no more than as the smallest particle of vapor to the immense ocean. Immeasurable regions of space lie beyond the utmost limits of mortal view, into which even imagination itself can scarcely penetrate, and which are, doubtless, replenished with the operations of Divine Wisdom and Omnipotence. For it cannot be supposed that a being so diminutive as man, whose stature scarcely exceeds six feet—who vanishes from the sight at the distance of a league—whose whole habitation is invisible from the nearest star—whose powers of vision are so imperfect, and whose mental faculties are so limited—it cannot be supposed that man, who "dwells in tabernacles of clay, who is crushed before the moth," and chained down, by the force of gravitation, to the

surface of a small planet, should be able to descry the utmost boundaries of the empire of Him who fills immensity, and dwells in "light inapproachable." That portion of his dominions, however, which lies within the range of our view, presents such a scene of magnificence and grandeur, as must fill the mind of every reflecting person with astonishment and reverence, and constrain him to exclaim, "Great is our Lord, and of great power, his understanding is infinite." "When I consider thy heavens, the work of thy fingers, the moon and the stars, which thou hast ordained; what is man, that thou art mindful of him?" "I have heard of thee by the hearing of the ear;" "I have listened to subtle disquisitions on thy character and perfections, and have been but little affected; "but now mine eye seeth thee: wherefore I humble myself, and repent in dust and ashes."

In order to feel the full force of the impression made by such contemplations, the mind must pause at every step in its excursions through the boundless regions of material existence; for it is not by a mere attention to the figures and numbers by which the magnitudes of the great bodies of the universe are expressed, that we arrive at the most distinct and ample conceptions of objects so grand and overwhelming. The mind, in its intellectual range, must dwell on every individual scene it contemplates, and on the various objects of which it is composed. It must add scene to scene, magnitude to magnitude, and compare smaller objects with greater—a range of mountains with the whole earth, the earth with the planet Jupiter, Jupiter with the sun, the sun with a thousand stars, a thousand stars with eighty millions, and eighty millions with all the boundless extent which lies beyond the limits of mortal vision; and, at every step of this mental process, sufficient time must be allowed for the imagination to expatiate on the objects before it, until the ideas approximate, as near as possible, to the reality. In order to form a comprehensive conception of the extent of the terraqueous globe, the mind must dwell on an extensive landscape, and the objects with which it is adorned; it must endeavor to survey the many thousands of diversified landscapes which the earth exhibits—the hills and plains, the lakes and rivers and mountains, which stretch in endless variety over its surface: it must dive into the vast caverns of the ocean—penetrate into the subterraneous regions of the globe, and wing its way, amidst clouds and tempests, through the surrounding atmosphere. It must next extend its flight through the more expansive regions of the solar system—realizing, in imagination, those magnificent scenes which can be described neither by the naked eye nor by the telescope; and comparing the extent of our sublunary world with the more magnificent globes that roll around us. Leaving the sun and all his attendant planets behind, until they have diminished to the size of a small twinkling star, it must next wing its way to the starry regions, and pass from one system of worlds to another, from one Nebula\* to another, from one region of Nebulae to another, until it arrive at the utmost boundaries of creation which human genius has explored. It must also endeavor to extend its flight beyond all that is visible by the best telescopes, and expatiate at large in that boundless expanse into which no human eye has yet penetrated, and which is doubtless replenished with other worlds, and systems, and firmaments, where the operations of infinite power and beneficence are displayed, in endless

\* For an account of the *Nebulae*, see ch. ii, Art. *Astronomy*.

variety, throughout the illimitable regions of space.

Here, then, with reverence, let us pause and wonder! Over all this vast assemblage of material existence, God presides. Amidst the diversified objects and intelligences it contains, he is eternally and essentially present. By his unerring wisdom, all its complicated movements are directed. By his Almighty fiat, it emerged from nothing into existence, and is continually supported from age to age. "HE SPAKE, AND IT WAS DONE; HE COMMANDED, AND IT STOOD FAST." "By the word of the Lord were the heavens made, and all the host of them by the spirit of his mouth." What an astonishing display of Divine power is here exhibited to our view! How far transcending all finite comprehension must be the energies of Him who only "spake, and it was done;" who only gave the command, and this mighty system of the universe, with all its magnificence, started into being! The infinite ease with which this vast fabric was reared, leads us irresistibly to conclude that there are powers and energies in the Divine mind which have never yet been exerted, and which may unfold themselves to intelligent beings, in the production of still more astonishing and magnificent effects, during an endless succession of existence. That man who is not impressed with a venerable and overwhelming sense of the power and majesty of Jehovah by such contemplations, must have a mind incapable of ardent religious emotions, and unqualified for appreciating the grandeur of that Being "whose kingdom ruleth over all." And shall such ennobling views be completely withheld from a Christian audience? Shall it be considered as a matter of mere indifference whether their views of the Creator's works be limited to the sphere of a few miles around them, or extended to ten thousand worlds?—whether they shall be left to view the operations of the Almighty throughout eternity past and to come, as confined to a small globe, placed in the immensity of space, with a number of brilliant studs fixed in the arch of heaven, at a few miles' distance, or, as extending through the boundless dimensions of space?—whether they shall be left to entertain no higher idea of the Divine Majesty than what may be due to one of the superior orders of the seraphim or cherubim; or, whether they shall be directed to form the most august conceptions of the King eternal, immortal, and invisible, corresponding to the displays he has given of his glory in his visible works? If it be not, both reason and piety require that such illustrations of the Divine perfections should occasionally be exhibited to their view.

In the next place, the *rapid motions* of the great bodies of the universe, no less than their magnitudes, display the infinite power of the Creator.

We can acquire accurate ideas of the relative velocities of moving bodies, only by comparing the motions with which we are familiar with one another, and with those which lie beyond the general range of our minute inspection. We can acquire a pretty accurate conception of the velocity of a ship impelled by the wind—of a steam-boat—of a race-horse—of a bird darting through the air—of an arrow flying from a bow—and of the clouds when impelled by a stormy wind. The velocity of a ship is from 8 to 12 miles an hour,—of a race-horse, from 20 to 30 miles,—of a bird, say from 50 to 60 miles, and of the clouds, in a violent hurricane, from 80 to 100 miles an hour. The motion of a ball from a loaded cannon is incomparably swifter than any of the motions now stated: but of the velocity of such a body we have

a less accurate idea; because, its rapidity being so great, we cannot trace it distinctly by the eye through its whole range, from the mouth of the cannon to the object against which it is impelled. By experiments, it has been found that its rate of motion is from 480 to 800 miles in an hour, but it is retarded every moment by the resistance of the air and the attraction of the earth. This velocity, however, great as it is, bears no sensible proportion to the rate of motion which is found among the celestial orbs. That such enormous masses of matter should move at all is wonderful: but when we consider the amazing velocity with which they are impelled, we are lost in astonishment. The planet Jupiter, in describing its circuit round the sun, moves at the rate of 29,000 miles an hour. The planet Venus, one of the nearest and most brilliant of the celestial bodies, and about the same size as the earth, is found to move through the spaces of the firmament at the rate of 76,000 miles an hour; and the planet Mercury, with a velocity of no less than 105,000 miles an hour, or 1750 miles in a minute—a motion two hundred times swifter than that of a cannon ball.

These velocities will appear still more astonishing, if we consider the magnitude of the bodies which are thus impelled, and the immense forces which are requisite to carry them along in their courses. However rapidly a ball flies from the mouth of a cannon, it is the flight of a body of only a *few inches* in diameter; but one of the bodies, whose motion has been just now stated, is *eighty-nine thousand miles* in diameter, and would comprehend within its vast circumference more than a thousand globes as large as the earth.—Could we contemplate such motions from a fixed point, at the distance of only a few hundreds of miles from the bodies thus impelled—it would raise our admiration to its highest pitch, it would overwhelm all our faculties, and, in our present state would produce an impression of awe, and even of terror, beyond the power of language to express. The earth contains a mass of matter equal in weight to at least 2,200,000,000,000,000,000,000, or more than two thousand trillions of tons, supposing its mean density to be only about  $2\frac{1}{2}$  times greater than water. To move this ponderous mass, a single inch beyond its position, were it fixed in a quiescent state, would require a mechanical force almost beyond the power of numbers to express. The physical force of all the myriads of intelligences within the bounds of the planetary system, though their powers were far superior to those of man, would be altogether inadequate to the production of such a motion. How much more must be the force requisite to impel it with a velocity one hundred and forty times swifter than a cannon ball, or 68,000 miles an hour, the actual rate of its motion, in its course round the sun! But whatever degree of mechanical power would be requisite to produce such a stupendous effect, it would require a force one hundred and fifty times greater to impel the planet Jupiter, in its actual course, through the heavens! Even the planet Saturn, one of the slowest moving bodies of our system, a globe 900 times larger than the earth, is impelled through the regions of space, at the rate of 22,000 miles an hour, carrying along with it two stupendous rings, and seven moons larger than ours, through its whole course round the central luminary. Were we placed within a thousand miles of this stupendous globe (a station which superior beings may occasionally occupy), where its hemisphere, encompassed by its magnificent rings, would fill the whole extent



of our vision—the view of such a ponderous and glorious object, flying with such amazing velocity before us, would infinitely exceed every idea of grandeur we can derive from terrestrial scenes, and overwhelm our powers with astonishment and awe. Under such an emotion, we could only exclaim, “GREAT AND MARVELOUS ARE THY WORKS, LORD GOD ALMIGHTY!” The ideas of *strength* and *power* implied in the impulsion of such enormous masses of matter, through the illimitable tracts of space, are forced upon the mind with irresistible energy, far surpassing what any abstract propositions or reasonings can convey; and, constrain us to exclaim, “Who is a strong Lord like unto thee! Thy right hand has become glorious unto power! The Lord God omnipotent reigneth!”

If we consider the *immense number* of bodies thus impelled through the vast spaces of the universe—the rapidity with which the *comets*, when near the sun, are carried through the regions they traverse,—if we consider the high probability, if not absolute certainty, that the sun, with all its attendant planets and comets, is impelled with a still greater degree of velocity toward some distant region of space, or around some wide circumference—that all the thousands of systems of that nebula to which the sun belongs are moving in a similar manner—that all the nebulae in the heavens are moving around some magnificent central body,—in short, that all the suns and worlds in the universe are in rapid and perpetual motion, as constituent portions of one grand and boundless empire, of which Jehovah is the Sovereign—and if we consider still further, that all these mighty movements have been going on, without intermission, during the course of many centuries, and some of them, perhaps, for myriads of ages before the foundation of our world was laid—it is impossible for the human mind to form any adequate idea of the stupendous forces which are in incessant operation throughout the unlimited empire of the Almighty. To estimate such mechanical force, even in a single instance, completely baffles the mathematician’s skill, and sets the power of numbers at defiance. “Language,” and figures, and comparisons, are “lost in wonders so sublime,” and the mind, overpowered with such reflections, is irresistibly led upward to search for the cause in that OMNIPOTENT BEING who upholds the pillars of the universe—the thunder of whose power none can comprehend.

While contemplating such august objects, how emphatic and impressive appears the language of the Sacred Oracles: “Canst thou by searching find out God? Canst thou find out the Almighty unto perfection? Great things doth he which we cannot comprehend. Thine, O Lord, is the greatness, and the glory, and the majesty; for all that is in heaven and earth is thine. Among the gods there is none like unto thee, O Lord; neither are there any works like unto thy works. Thou art great, and dost wondrous things: thou art God alone. Hast thou not known, hast thou not heard, that the everlasting God, the Lord, the Creator of all things, fainteth not, neither is weary? there is no searching of his understanding. Let all the earth fear the Lord, let all the inhabitants of the world stand in awe of him; for he *spake*, and it was done; he commanded, and it stood fast.”

Again, the *immense spaces* which surround the heavenly bodies, and in which they perform their revolutions, tend to expand our conceptions on this subject, and to illustrate the magnificence of the Divine operations. In whatever point of view we contemplate the scenery of the heavens, an

idea of grandeur irresistibly bursts upon the mind; and if empty space can, in any sense, be considered as an object of sublimity, nothing can fill the mind with a grander idea of magnitude and extension than the amplitude of the scale on which planetary systems are constructed. Around the body of the sun there is allotted a cubical space, 5600 millions of miles in diameter, in which eleven planetary globes revolve—every one being separated from another, by intervals of many millions of miles. The space which surrounds the utmost limits of our system, extending, in every direction, to the nearest fixed stars, is at least 40,000,000,000,000, or forty billions of miles in diameter; and, it is highly probable, that every star is surrounded by a space of equal or even of greater extent. A body impelled with the greatest velocity which art can produce—a cannon ball, for instance—would require twenty years to pass through the space that intervenes between the earth and the sun, and four millions seven hundred thousand years ere it could reach the nearest star. Though the stars seem to be crowded together in clusters, and some of them almost to touch one another, yet the distance between any two stars which seem to make the nearest approach, is such as neither words can express, nor imagination fathom. These immense spaces are as unfathomable, on the one hand, as the magnitude of the bodies which move in them, and their prodigious velocities are incomprehensible, on the other; and they form a part of those magnificent proportions according to which the fabric of universal nature was arranged—all corresponding to the majesty of that infinite and incomprehensible Being, “who measures the ocean in the hollow of his hand, and meteth out the heavens with a span.” How wonderful that bodies at such prodigious distances should exert a mutual influence on one another! that the moon, at the distance of 240,000 miles, should raise tides in the ocean, and currents in the atmosphere! that the sun, at the distance of ninety-five millions of miles, should raise the vapors, move the ocean, direct the course of the winds, fructify the earth, and distribute light, and heat, and color, through every region of the globe! yea, that its attractive influence and fructifying energy should extend even to the planet Herschel, at the distance of eighteen hundred millions of miles! So that, in every point of view in which the universe is contemplated, we perceive the same *grand scale* of operation by which the Almighty has arranged the provinces of his universal kingdom.

We would now ask, in the name of all that is sacred, whether such magnificent manifestations of Deity ought to be considered as irrelevant in the business of religion, and whether they ought to be thrown completely into the shade, in the discussions which take place on religious topics, in “the assemblies of the saints!” If religion consist in the intellectual apprehension of the perfections of God, and in the moral effects produced by such an apprehension—if all the rays of glory emitted by the luminaries of heaven are only so many reflections of the grandeur of Him who dwells in light inaccessible—if they have a tendency to assist the mind in forming its conceptions of that ineffable Being, whose uncreated glory cannot be directly contemplated—and if they are calculated to produce a sublime and awful impression on all created intelligences,—shall we rest contented with a less glorious idea of God than his works are calculated to afford? Shall we disregard the works of the Lord, and contemn the operations of his hands, and that too in the

face of all the invitations on this subject addressed to us from heaven? For thus saith Jehovah—"Lift up your eyes on high, and behold, who hath created these things—who bringeth forth their host by number?—I the Lord, who maketh all things, who stretched forth the heavens alone, and spread abroad the earth by myself; all their host have I commanded." And if, at the command of God, we lift our eyes to the "firmament of his power," surely we ought to do it not with a "brute unconscious gaze," not with the vacant stare of a savage, not as if we were still enveloped with the mists and prejudices of the dark ages—but as surrounded by that blaze of light which modern science has thrown upon the scenery of the sky, in order that we may contemplate, with fixed attention, all that enlightened reason, aided by the nicest observations, has ascertained respecting the magnificence of the celestial orbs. To overlook the sublime discoveries of modern times, to despise them, or to call in question their reality as some religionists have done, because they bring to our ears such astonishing reports of "the eternal power" and majesty of Jehovah—is to act as if we were afraid lest the Deity should be represented as more grand and magnificent than he really is, and as if we would be better pleased to pay him a less share of homage and adoration than is due to his name.

Perhaps some may be disposed to insinuate, that the views now stated are above the level of ordinary comprehension, and founded too much on scientific considerations, to be stated in detail to a common audience. To any insinuations of this kind it may be replied, that such illustrations as those to which we have referred, are more easily comprehended than many of those abstract discussions to which they are frequently accustomed; since they are definite and tangible, being derived from those objects which strike the senses and the imagination. Any person of common understanding may be made to comprehend the leading ideas of extended space, magnitude, and motion, which have been stated above, provided the descriptions be sufficiently simple, clear, and well-defined; and should they be at a loss to comprehend the principles on which the conclusions rest, or the mode by which the magnificence of the works of God has been ascertained, an occasional reference to such topics would excite them to inquiry and investigation, and to the exercise of their powers of observation and reasoning on such subjects—which are too frequently directed to far less important objects.

The following illustration, however, stands clear of every objection of this kind, and is level to the comprehension of every man of common sense:—Either the earth moves round its axis once in twenty-four hours—or the sun, moon, planets, comets, stars, or the whole frame of the universe, move around the earth in the same time. There is no alternative, or third opinion, that can be formed on this point. If the earth revolve on its axis every twenty-four hours, to produce the alternate succession of day and night, the portions of its surface about the equator must move at the rate of more than a thousand miles an hour, since the earth is more than twenty-four thousand miles in circumference. This view of the fact, when attentively considered, furnishes a most sublime and astonishing idea. That a globe of so vast dimensions, with all its load of mountains, continents, and oceans, comprising within its circumference a mass of two hundred and sixty-four thousand millions of cubical miles, should whirl round with so amazing a velocity, gives us a most

august and impressive conception of the greatness of that Power which first set it in motion, and continues the rapid whirl from age to age!—Though the huge masses of the Alpine mountains were in a moment detached from their foundations, carried aloft through the regions of the air, and tossed into the Mediterranean sea, it would convey no idea of a force equal to that which is every moment exerted, if the earth revolve on its axis. But should the motion of the earth be called in question, or denied, the idea of force, or power, will be indefinitely increased.—For, in this case, it must necessarily be admitted that the heavens, with all the innumerable hosts of stars, have a diurnal motion around our globe; which motion must be inconceivably more rapid than that of the earth, on the supposition of its motion. For, in proportion as the celestial bodies are distant from the earth, in the same proportion would be the rapidity of their movements. The sun, on this supposition, would move at the rate of 414,000 miles in a minute; the nearest stars at the rate of fourteen hundred millions of miles in a second; and the most distant luminaries, with a degree of swiftness which no numbers could express.\* Such velocities, too, would be the rate of motion, not merely of a single globe like the earth, but of all the ten thousand times ten thousand spacious globes that exist within the boundaries of creation. This view conveys an idea of power still more august and overwhelming than any of the views already stated, and we dare not presume to assert that such a degree of physical force is beyond the limits of Infinite perfection: but on the supposition it existed, it would confound all our ideas of the wisdom and intelligence of the Divine mind, and would appear altogether inconsistent with the character which the Scriptures give us of the Deity as "the only-wise God." For it would exhibit a stupendous system of means altogether disproportioned to the end intended; namely, to produce the alternate succession of day and night to the inhabitants of our globe, which is more beautifully and harmoniously effected by a single rotation on its axis, as is the case with the other globes which compose the planetary system. Such considerations, however, show us that, on whatever hypothesis, whether on the vulgar or the scientific, or in whatever other point of view the frame of nature may be contemplated, the mind is irresistibly impressed with ideas of power, grandeur, and magnificence. And, therefore, when an inquiring mind is directed to contemplate the works of God, on any hypothesis it may choose, it has a tendency to rouse reflection, and to stimulate the exercise of the moral and intellectual faculties, on objects which are worthy of the dignity of immortal minds.

We may now be, in some measure, prepared to decide, whether illustrations of the Omnipotence of the Deity, derived from the system of the material world, or those vague and metaphysical disquisitions which are generally given in theological systems, be most calculated to impress the mind, and to inspire it with reverence and adoration. The following is a description given of this attribute of God, by a well-known systematic writer, who has generally been considered as a judicious and orthodox divine:—

"God is Almighty.† This will evidently appear, in that, if he be infinite in all his other perfections, he must be so in power; thus, if he be

\* See Appendix, Note 1.

† Rev. i. 18; iv. 8.

omniscient, he knows what is possible or expedient to be done; and if he be an infinite sovereign, he wills whatever shall come to pass. Now this knowledge would be insignificant, and his power inefficacious, were he not infinite in power, or almighty. Again, this might be argued from his justice, either in rewarding or punishing; for, if he were not infinite in power, he could do neither of these, at least so far as to render him the object of that desire or fear, which is agreeable to the nature of these perfections; neither could infinite faithfulness accomplish all the promises which he hath made, so as to excite that trust and dependence, which is a part of religious worship; nor could he say without limitation, as he does, *I have spoken it, I will also bring it to pass: I have purposed it, I will also do it.\** But since power is visible in, and demonstrated by its effects, and infinite power by those effects which cannot be produced by a creature, we may observe the almighty power of God in all his works, both of nature and grace; thus his eternal power is understood, as the apostle says, *by the things that are made;*† not that there was an eternal production of things, but the exerting this power in time, proves it to be infinite and truly divine; for no creature can produce the smallest particle of matter out of nothing, much less furnish the various species of creatures with those endowments in which they excel one another, and set forth their Creator's glory. And the glory of his power is no less visible in the works of providence, whereby he upholds all things, disposes of them according to his pleasure, and brings about events which only he who has an almighty arm can effect.‡

This is the whole that Dr. Ridgely judges it necessary to state in illustration of the attribute of Omnipotence, except what he says in relation to its operation in "the work of grace," in "the propagation and success of the Gospel," etc.; subjects to which the idea of power, or physical energy, does not properly apply. Such, however, are the meager and abstract disquisitions generally given by most systematic writers. There is a continual play on the term "Infinite," which, to most minds conveys no idea at all, unless it be associated with ample conceptions of motion, magnitude, and extension; and it is constantly applied to subjects to which it was never intended to apply, such as "infinite faithfulness, infinite justice, infinite truth," etc.; an application of the term which is never sanctioned by Scripture, and which has a tendency to introduce confusion into our conceptions of the perfections of God.—Granting that the statements and reasonings in such an extract as the above were unquestionable, yet what impression can they make upon the mind? Would an ignorant person feel his conception of the Divinity much enlarged, or his moral powers aroused by such vague and general statements? And, if not, it appears somewhat unaccountable, that those sources of illustration which would convey the most ample and definite views of the "eternal power" and glory of God, should be studiously concealed from the view.—Vague descriptions and general views of any object will never be effectual in awakening the attention and arresting the faculties of the mind. The heart will always remain unimpressed, and the understanding will never be thoroughly excited in its exercise, unless the intellect have presented before it a well-defined and interesting object, and be enabled to survey it in its various

aspects; and this object must always have a relation to the material world, whether it be viewed in connection with religion or with any other subject.

Thus, I have endeavored, in the preceding sketches, to present a few detached illustrations of the Omnipotence and grandeur of the Deity, as displayed in the vast magnitude of the material universe—the stupendous velocities of the celestial bodies—and in the immeasurable regions of space which surround them, and in which their motions are performed. Such a magnificent spectacle as the fabric of the universe presents—so majestic, godlike, and overwhelming, to beings who dwell "in tabernacles of clay"—was surely never intended to be overlooked, or to be gazed at with indifference, by creatures endowed with reason and intelligence, and destined to an immortal existence. In forming a universe composed of so many immense systems and worlds, and replenished with such a variety of sensitive and intelligent existences, the Creator, doubtless, intended that it should make a sublime and reverential impression on the minds of all the intellectual beings to whom it might be displayed, and that it should convey some *palpable* idea of the infinite glories of his nature, in so far as material objects can be supposed to adumbrate the perfections of a spiritual and uncreated Essence. Dwelling in light "inaccessible" to mortals, and forever veiled from the highest created being, by the pure spirituality and immensity of his nature, there is no conceivable mode by which the infinite grandeur of Deity could be exhibited to finite intelligences, but through the medium of those magnificent operations which are incessantly going forward throughout the boundless regions of space. Concealed from the gaze of all the "principalities and powers" in heaven, in the unfathomable depths of his Essence, he displays his presence in the universe he has created, and the glory of his power, by launching magnificent worlds into existence, by adorning them with diversified splendors, by peopling them with various ranks of intelligent existence, and by impelling them in their movements through the illimitable tracts of creation.

It will readily be admitted by every enlightened Christian, that it must be a highly desirable attainment, to acquire the most glorious idea of the Divine Being, which the limited capacity of our minds is capable of receiving. This is one of the grand difficulties in religion. The idea of a Being purely IMMATERIAL, yet pervading infinite space, and possessed of no sensible qualities, confounds and bewilders the human intellect, so that its conceptions, on the one hand, are apt to verge toward extravagancy, while, on the other, they are apt to degenerate into something approaching to inanity. Mere abstract ideas and reasonings respecting infinity, eternity, and absolute perfection, however sublime we may conceive them to be, completely fail in arresting the understanding, and affecting the heart; our conceptions become vague, empty, and confused, for want of a material vehicle to give them order, stability, and expansion. Something of the nature of vast extension, of splendid and variegated objects, and of mighty movements, is absolutely necessary, in order to convey to spirits dwelling in bodies of clay, a definite conception of the invisible glories of the Eternal Mind; and, therefore, in the immense variety of material existence with which the universe is adorned, we find every requisite assistance of this kind to direct and expand our views of the Great Object of our adoration. When the mind is per-

\* Isaiah xli. 11.

† Romans i. 20.

‡ Ridgely's Body of Divinity, p. 39.

plexed and overwhelmed with its conceptions, when it labors, as it were, to form some well defined conceptions of an Infinite Being, it here finds some tangible objects on which to fix, some sensible *substratum* for its thoughts to rest upon for a little, while it attempts to penetrate, in its excursions, into those distant regions which eye hath not seen, and to connect the whole of its mental survey with the energies of the "King Eternal, Immortal, and Invisibile."

To such a train of thought we are uniformly directed in the Sacred Oracles, where Jehovah is represented as describing himself by the *effects* which his power and wisdom have produced:—"Israel shall be saved in the Lord with an everlasting salvation. For thus saith Jehovah that created the heavens; God himself that formed the earth and made it; he hath established it, he created it not in vain, he formed it to be inhabited; I am the Lord, and there is none else." "I have made the earth and created man upon it, my hands have stretched out the heavens, and all their hosts have I commanded. Harken unto me, O Israel: I am the first, I also am the last. Mine hand also hath laid the foundation of the earth, and my right hand hath spanned the heavens; when I call unto them, they stand up together. Who hath measured the waters in the hollow of his hand, and meted out heaven with a span, and weighed the mountains in scales? He who sitteth upon the circle of the earth, and the inhabitants thereof are as grasshoppers; that stretcheth out the heavens as a curtain, that faintheth not, neither is weary." "The Lord made the heavens, the heaven of heavens, with all their hosts; honor and majesty are before him, and his kingdom ruleth over all."\*—Such sublime descriptions of Jehovah, and references to his material works, are reiterated in every portion of the sacred volume: and the import and sublimity of such expressions cannot be fully appreciated, unless we take into view all the magnificent objects which science has unveiled in the distant regions of creation.

This subject is calculated, not merely to overpower the intellect with an idea of sublimity and grandeur, but also to produce deep *moral* impressions upon the heart; and a Christian philosopher would be deficient in his duty were he to overlook this tendency of the objects of his contemplation.

One important moral effect which this subject has a natural tendency to produce, is, profound *humility*. What an insignificant being does man appear, when he compares himself with the magnificence of creation, and with the myriads of exalted intelligences with which it is peopled! What are all the honors and splendors of this earthly ball, of which mortals are so proud, when placed in competition with the resplendent glories of the skies! Such a display as the Almighty has given of himself, in the magnitude and variety of his works, was evidently intended "to stain the pride" of all human grandeur, that "no flesh should glory in his presence." Yet there is no disposition that appears so prominent among puny mortals as pride, ambition, and vain-glory—the very opposite of humility, and of all those tempers which become those "who dwell in tabernacles of clay, and whose foundation is in the dust." Even without taking into account the state of man as a *depraved* intelligence, what is there in his situation that should inspire him with "lofty looks," and induce him to look down on his fellow-men with supercilious contempt? He

derived his origin from the dust, he is allied to the beasts that perish, and he is fast hastening to the grave, where his carcass will become the food of noisome reptiles. He is every moment dependent on a Superior Being for every pulse that beats, and every breath he draws, and for all that he possesses; he is dependent even on the meanest of his species for his accommodations and comforts. He holds every enjoyment on the most precarious tenure,—his friends may be snatched in a moment from his embrace; his riches may take to themselves wings and fly away; and his health and beauty may be blasted in an hour, by a breath of wind. Hunger and thirst, cold and heat, poverty and disgrace, sorrow and disappointment, pain and disease, mingle themselves with all his pursuits and enjoyments. His knowledge is circumscribed within the narrowest limits, his errors and follies are glaring and innumerable; and he stands as an almost undistinguishable atom, amidst the immensity of God's works. Still, with all these powerful inducements to the exercise of humility, man dares to be proud and arrogant:

"Man, proud man,  
Dress'd in a little brief authority,  
Plays such fantastic tricks before high heaven,  
As make the angels weep."

How affecting to contemplate the warrior, flushed with diabolical pride, pursuing his conquests through heaps of slain, in order to obtain possession of "a poor pitiable speck of perishing earth;" exclaiming in his rage, "I will pursue, I will overtake, I will divide the spoil, my lust shall be satisfied upon them, I will draw the sword, my hand shall destroy them!"—to behold the man of rank glorying in his wealth, and his empty titles, and looking around upon the inferior orders of his fellow-mortals as the worms of the dust—to behold the man of ambition pushing his way through bribery, and treachery, and slaughter, to gain possession of a throne, that he may look down with proud pre-eminence upon his fellows—to behold the haughty airs of the noble dame, inflated with the idea of her beauty, and her high birth, as she struts along, surveying the ignoble crowd, as if they were the dust beneath her feet—to behold the smatterer in learning, puffed up with a vain conceit of his superficial acquirements, when he has scarcely entered the porch of knowledge,—in fine, to behold all ranks, from the highest to the lowest, big with an idea of their own importance, and fired with pride and revenge at the least provocation, whether imaginary or real! How inconsistent the manifestations of such tempers, with the many humiliating circumstances of our present condition, and with the low rank which we hold in the scale of Universal Being.

It is not improbable, that there are in the universe, intelligences of a superior order, in whose breasts pride never found a place—to whom this globe of ours, and all its inhabitants, appear as inconsiderable as a drop of water, filled with microscopic animalcules, does to the proud lords of this earthly region. There is at least *one* Being to whom this sentiment is applicable, in its utmost extent:—"Before Him all nations are as a drop of a bucket, and the inhabitants of the earth as grasshoppers; yea, they are as nothing, and are counted to him less than nothing and vanity." Could we wing our way with the swiftness of a seraph, from sun to sun, and from world to world, until we had surveyed all the systems visible to the naked eye, which are only as a mere speck in the map of the universe—could we, at the same time, contemplate the glorious landscapes and

\* Isaiah xlv. 17, 18; xlviii. 12, 13; xl. 12, 22, etc.

scenes of grandeur they exhibit—could we also mingle with the pure and exalted intelligences which people those resplendent abodes, and behold their humble and ardent adorations of their Almighty Maker, their benign and condescending deportment toward one another; “each esteeming another better than himself,” and all united in the bonds of the purest affection, without one haughty or discordant feeling—what indignation and astonishment would seize us on our return to this obscure corner of creation, to behold beings enveloped in the mists of ignorance, immersed in depravity and wickedness, liable to a thousand accidents, exposed to the ravages of the earthquake, the volcano, and the storm; yet proud as Lucifer, and glorying in their shame! We should be apt to view them, as we now do those bedlamites, who fancy themselves to be kings, surrounded by their nobles, while they are chained to the walls of a noisome dungeon. “Sure pride was never made for man.” How abhorrent, then, must it appear in the eyes of superior beings, who have taken an expansive range through the field of creation! How abhorrent it is in the sight of the Almighty, and how amiable is the opposite virtue, we learn from his word:—“Every one that is proud in heart is an abomination to the Lord.”—“God resisteth the proud, but he giveth grace to the humble.”—“Thus saith the High and Lofty One, who inhabiteth eternity, I dwell in the high and holy place; with him also that is of an humble and contrite spirit; to revive the spirit of the humble, and the heart of the contrite ones.”—While, therefore, we contemplate the Omnipotence of God in the immensity of creation, let us learn to cultivate humility and self-abasement. This was one of the lessons which the pious Psalmist deduced from his survey of the nocturnal heavens. When he beheld the moon walking in brightness, and the innumerable host of stars—overpowered with a sense of his own insignificance, and the greatness of Divine condescension, he exclaimed, “O Lord! what is man, that thou art mindful of him, or the son of man, that thou shouldst visit him!”

Again, this subject is also calculated to inspire us with REVERENCE and VENERATION of God. Profound veneration of the Divine Being lies at the foundation of all religious worship and obedience. But, in order to reverence God aright, we must know him; and, in order to acquire the true knowledge of him, we must contemplate him through the medium of those works and dispensations, by which he displays the glories of his nature to the inhabitants of our world. I have already exhibited a few specimens of the stupendous operations of his power, in that portion of the system of the universe which lies open to our inspection; and there is, surely, no mind in which the least spark of piety exists, but must feel strong emotions of reverence and awe, at the thought of that Almighty and Incomprehensible Being, who impels the huge masses of the planetary globes with so amazing a rapidity through the sky, and who has diversified the voids of space with so vast an assemblage of magnificent worlds. Even those manifestations of Deity which are confined to the globe we inhabit, when attentively considered, are calculated to rouse, even the unthinking mind, to astonishment and awe. The lofty mountains, and expansive plains, the mass of waters in the mighty ocean, the thunders rolling along the sky, the lightnings flashing from cloud to cloud, the hurricane and the tempest, the volcano vomiting rivers of fire, and the earthquake shaking kingdoms, and leveling cities with

the ground—all proclaim the Majesty of Him, by whom the elements of nature are arranged and directed, and seem to address the sons of men in language like this: “The Lord reigneth, he is clothed with majesty; at his wrath the earth trembles; a fire goeth before him, and burneth up his enemies.”—“Let all the earth fear the Lord, let all the inhabitants of the world stand in awe of him.”

There is one reason, among others, why the bulk of mankind feel so little veneration of God, and that is, that they seldom contemplate, with fixed attention, “the operations of his hands.” If we wish to cherish this sublime sentiment in our hearts, we must familiarize our minds to frequent excursions over all those scenes of Creation and Providence, which the volume of nature, and the volume of inspiration, unfold to view. We must endeavor to assist our conceptions of the grandeur of these objects, by every discovery which has been, or may yet be made, and by every mode of illustration by which a sublime and comprehensive idea of the particular object of contemplation may be obtained.—If we would wish to acquire some definite, though imperfect conception of the physical extent of the universe, our minds might be assisted by such illustrations as the following:—Light flies from the sun with a velocity of nearly two hundred thousand miles in a moment of time, or about 1,400,000 times swifter than the motion of a cannon ball. Suppose that one of the highest order of intelligences is endowed with a power of rapid motion superior to that of light, and with a corresponding degree of intellectual energy; that he has been flying, without intermission, from one province of creation to another, for six thousand years, and will continue the same rapid course for a thousand millions of years to come; it is highly probable, if not absolutely certain, that at the end of this vast tour, he would have advanced no farther than “the suburbs of creation”—and that all the magnificent systems of material and intellectual beings he had surveyed during his rapid flight, and for such a length of ages, bear no more proportion to the whole Empire of Omnipotence, than the smallest grain of sand does to all the particles of matter of the same size contained in ten thousand worlds. Nor need we entertain the least fear, that the idea of the extent of the Creator’s power, conveyed by such a representation, exceeds the bounds of reality. On the other hand, it must fall almost infinitely short of it. For, as the poet has justly observed—

“Can man conceive beyond what God can do?”

Were a seraph, in prosecuting the tour of creation in the manner now stated, ever to arrive at a limit beyond which no further displays of the Divinity could be perceived, the thought would overwhelm his faculties with unutterable anguish and horror; he would feel, that he had now, in some measure, comprehended all the plans and operations of Omnipotence, and that no further manifestations of the Divine glory remained to be explored. But we may rest assured, that this can never happen in the case of any created intelligence. We have every reason to believe, both from the nature of an Infinite Being, and from the vast extent of creation already explored, that the immense mass of material existence, and the endless variety of sensitive and intellectual beings with which the universe is replenished, are intended by Jehovah, to present to his rational offspring, a *shadow*, an *emblem*, or a *representation* (in so far as finite extended existence can be a

representation) of the *Infinite Perfections* of his nature, which would otherwise have remained forever impalpable to all subordinate intelligences.

In this manner, then, might we occasionally exercise our minds on the grand and diversified objects which the universe exhibits; and, in proportion as we enlarge the sphere of our contemplations, in a similar proportion will our views of God himself be extended, and a corresponding sentiment of veneration impressed upon the mind. For the soul of man cannot reverence a mere abstract being, that was never manifested through a sensible medium, however many lofty terms may be used to describe his perfections. It reverences that ineffable being, who conceals himself behind the scenes of Creation, through the medium of the visible display he exhibits of his Power, Wisdom, and Beneficence, in the economy of Nature, and in the Records of Revelation.—Before the universe was formed, Jehovah existed alone, possessed of every attribute which he now displays. But, had only one solitary intelligence been created, and placed in the infinite void, without a material substratum beneath and around him, he could never have been animated with a sentiment of profound veneration for his Creator; because no objects existed to excite it, or to show that his Invisible Maker was invested with those attributes which he is now known to possess. Accordingly, we find in the sacred writings, that, when a sentiment of reverence is demanded from the sons of men, those sensible objects which are calculated to excite the emotion are uniformly exhibited. “Fear ye not me, saith the Lord? Will ye not tremble at my presence, who have placed the sand for the bound of the sea, by a perpetual decree, that it cannot pass it; and though the waves thereof toss themselves, yet they cannot prevail; though they roar, yet can they not pass over it?” “Who would not fear thee, O King of nations! Thou art the true God, and an everlasting King. Thou hast made the earth by thy power, thou hast established the world by thy wisdom, thou hast stretched out the heavens by thy discretion. When thou utterest thy voice there is a noise of waters in the heavens, thou caustest the vapors to ascend from the ends of the earth, thou makest lightnings with rain, and bringest forth the winds out of thy treasures.”\*

But however enlarged and venerable conceptions of God we may derive from the manifestations of his power, they must fall infinitely short of what is due to a being of boundless perfection. For there may be attributes in the Divine Essence of which we cannot possibly form the least conception—attributes which cannot be shadowed forth or represented by any portion of the material or intellectual world yet discovered by us, or by all the mighty achievements by which human redemption was effected—attributes which have not yet been displayed, in their effects, to the highest orders of intelligent existence. And therefore, as that excellent philosopher and divine, the honorable Mr. Boyle, has well observed, “Our ideas of God, however great, will rather express the greatness of our veneration than the immensity of his perfections; and the notions worthy the most intelligent men are far short of being worthy the incomprehensible God—the brightest idea we can frame of God being infinitely inferior, and no more than a *Parhelion* † in respect of the sun; for

though that meteor is splendid, and resembles the sun, yet it resides in a cloud, and is not only much beneath the sun in distance, but inferior in bigness and splendor.”

In short, were we habitually to cherish that profound veneration of God which his works are calculated to inspire, with what humility would we approach the presence of this August Being! with what emotions of awe would we present our adorations! and with what reverence would we talk of his inscrutable purposes and incomprehensible operations! We would not talk about him as some writers have done, with the same ease and indifference as a mathematician would talk about the properties of a triangle, or a philosopher about the effects of a mechanical engine; nor would we treat with a spirit of levity any of the solemn declarations of his word, or the mighty movements of his providence. We would be ever ready to join with ardor in the sublime devotions of the inspired writers, “Great and marvelous are thy works, Lord God Almighty, just and true are thy ways, thou King of saints! Who would not fear thee, O Lord, and glorify thy name? Let all the earth fear the Lord, let all the inhabitants of the world stand in awe of him.”

Lastly, The views we have taken of the omnipotence and grandeur of the Deity are calculated to inspire us with HOPE and CONFIDENCE in the prospect of that eternal existence which lies before us. The period of our existence in this terrestrial scene will soon terminate, and those bodies, through which we now hold a correspondence with the visible creation, crumble into dust. The gradual decay, and the ultimate dissolution of human bodies, present a scene at which reason stands aghast; and, on a cursory survey of the chambers of the dead, it is apt to exclaim, in the language of despair, “Can these dry bones live?” A thousand difficulties crowd upon the mind which appear repugnant to the idea, that beauty shall again spring out of ashes, and life out of the dust. But, when we look abroad to the displays of Divine power and intelligence, in the wide expanse of Creation, we perceive that

“Almighty God

Has done much more; nor is his arm impaired  
Through length of days.—And what he can, he will;  
His faithfulness stands bound to see it done.”—BLAIR.

We perceive that he has created systems in such vast profusion that no man can number them. The worlds every moment under his superintendence and direction are unquestionably far more numerous than all the human beings who have hitherto existed, or will yet exist until the close of time. And if he has not only arranged the general features of each of these worlds, and established the physical laws by which its economy is regulated, but has also arranged the diversified circumstances, and directs the minutest movements of the myriads of sensitive and intellectual existences it contains, we ought never for a moment to doubt that the minutest particles of every human body, however widely separated from each other, and mingled with other extraneous substances, are known to Him whose presence pervades all space; and that all the atoms requisite for the construction of the Resurrection-body will be reassembled for this purpose “by the energy of that mighty power whereby he is able

\* Jeremiah x. 7-13.

† A *Parhelion*, or *Mock-Sun*, is a meteor in the form of a very bright light appearing on one side of the sun, and somewhat resembling the appearance of that luminary. This

phenomenon is supposed to be produced by the refraction and reflection of the sun's rays from a watery cloud. Some times three or four of these parhelia, all of them bearing a certain resemblance to the real sun, have been seen at one time.

to subdue all things to himself." If we suppose that a number of human beings, amounting to three hundred thousand millions, shall start from the grave into new life at the general resurrection, and that the atoms of each of these bodies are just now under the special superintendence of the Almighty—and that, at least, an equal number of worlds are under his particular care and direction—the exertion of power and intelligence, in the former case, cannot be supposed to be greater than what is requisite in the latter. To a Being possessed of Infinite Power, conjoined with Boundless Intelligence, the superintendence of countless atoms, and of countless worlds, is equally easy, where no contradiction is implied. For, as the poet has well observed,—

"He summons into being with like ease  
A whole creation and a single grain."

And since this subject tends to strengthen our hope of a resurrection from the dead, it is also calculated to inspire us with confidence in the prospect of those eternal scenes which will burst upon the view, at the dissolution of all terrestrial things. Beyond the period fixed for the conflagration of this world, "a wide and unbounded prospect lies before us:" and though, at present, "shadows, clouds, and darkness rest upon it," yet the boundless magnificence of the Divine empire which science has unfolded, throws a radiance over the scenes of futurity, which is fraught with consolation, in the view of "the wreck of matter and the crash of worlds." It opens to us a prospect of perpetual improvement in knowledge and felicity; it presents a field in which the human faculties may be forever expanding, forever contemplating new scenes of grandeur rising to the view, in boundless perspective, through an interminable succession of existence. It convinces us, that the happiness of the eternal state will not consist in an unvaried repetition of the same perceptions and enjoyments, but that new displays of the Creator's glory will be continually bursting on the astonished mind, world without end. And as we know that the same beneficence and care which are displayed in the arrangements of systems of worlds, are also displayed in supporting and providing for the smallest microscopic animalcule, we have no reason to harbor the least fear lest we should be overlooked in the immensity of creation, or lost amidst the multiplicity of those works among which the Deity is incessantly employed: For, as he is *Omnipresent*, his essence pervades, actuates, and supports the whole frame of universal nature, and all the beings it contains, so that he is as intimately present with every created being, whether sensitive or intellectual, as that being is to itself. And as he is *Omniscient*, he is conscious of every movement that can arise in the material system, and of every thought and purpose that can pervade the world of intellectual existence.—and consequently his superintendence and care must extend to every creature he has formed. Therefore, though the "elements shall melt with fervent heat, and the earth and all the works therein be dissolved, yet we, according to his promise, look for new heavens and a new earth, wherein dwelleth righteousness."

### SECTION III.

#### ON THE WISDOM AND INTELLIGENCE OF THE DEITY.

In surveying the system of nature with a Christian and a philosophic eye, it may be con-

sidered in different points of view. It may be viewed either as displaying the power and magnificence of the Deity in the immense quantity of materials of which it is composed, and in the august machinery and movements by which its economy is directed;—or, as manifesting his Wisdom in the nice adaptation of every minute circumstance to the end it was intended to accomplish;—or, as illustrating his unbounded beneficence in the provision which is made for the accommodation and happiness of the numerous tribes of sentient and intelligent beings it contains. Having, in the preceding section, endeavored to exhibit some of those objects which evince the Omnipotence of Deity, and the pious emotions they are calculated to excite, I shall now offer a few popular illustrations of Divine Wisdom, as displayed in the arrangements of the material world—which shall chiefly be confined to those objects which are most prominent and obvious to the vulgar eye.

*Wisdom* is that perfection of an intelligent agent, by which he is enabled to select and employ the most proper means in order to accomplish a good and important end. It includes the idea of knowledge or intelligence, but may be distinguished from it. Knowledge is opposed to ignorance, Wisdom is opposed to folly or error in conduct. As applied to God, it may be considered as comprehending the operations of his Omniscience and Benevolence; or, in other words, his knowledge to discern, and his disposition to choose those means and ends which are calculated to promote the order and the happiness of the universe.

The Wisdom of God is, doubtless, displayed in every arrangement he has made throughout all the provinces of his immense and eternal kingdom, however far they may be removed from the sphere of human observation. But it is only in those parts of the system of nature which lie open to our particular investigation, that the traces of this perfection can be distinctly perceived. The heavens declare the glory of God's Wisdom, as well as of his Power. The planetary system—that portion of the heavens with which we are best acquainted—displays both the magnificence and the skill of its Divine Author,—in the magnitudes, distances, revolutions, proportions, and uses of the various globes of which it is composed, and in the diversified apparatus by which light and darkness are alternately distributed. The sun, an immense luminous world, by far the largest body in the system, is placed in the center. No other position would have suited for an equable distribution of illumination and heat through the different parts of the system. Around him, at different distances, eleven primary planets revolve, accompanied with eighteen secondaries or moons.—all in majestic order and harmony, no one interrupting the movements of another, but invariably keeping the paths prescribed them, and performing their revolutions in their appointed times. To all these revolving globes, the sun dispenses motion, light, heat, fertility, and other unceasing energies, for the comfort and happiness of their respective inhabitants—without which, perpetual sterility, eternal winter, and eternal night, would reign over every region of our globe, and throughout surrounding worlds.

The distance at which the heavenly bodies, particularly the sun, are placed from the earth, is a manifest evidence of Divine Wisdom. If the sun were much nearer us than he is at present, the earth, as now constituted, would be wasted and parched with excessive heat; the waters would be

turned into vapor, and the rivers, seas, and oceans, would soon disappear, leaving nothing behind them but frightful barren dells and gloomy caverns; vegetation would completely cease, and the tribes of animated nature languish and die. On the other hand, were the sun much farther distant than he now is, or were his bulk, or the influence of his rays diminished one half of what they now are, the land and the ocean would soon become one frozen mass, and universal desolation and sterility would overspread the fair face of nature; and instead of a pleasant and comfortable abode, our globe would become a frightful desert, a state of misery and perpetual punishment.\* But herein is the wisdom of God displayed, that he has formed the sun of such a determinate size, and placed it at such a convenient distance, as not to annoy, but to refresh and cheer us, and to enliven the soil with its genial influence; so that we plainly perceive, to use the language of the prophet, that "He hath established the world by his wisdom, and stretched out the heavens by his understanding."

The rotation of the several planetary globes around their axes, to produce the alternate succession of day and night, strikingly demonstrates the wisdom and benevolence of their great Author. Were the earth and the other planetary worlds destitute of a diurnal motion, only one-half of their surfaces could be inhabited, and the other half would remain a dark and cheerless desert. The sun would be the only heavenly orb which would be recognized by the inhabitants of each respective world, as existing in the universe, and that scene of grandeur which night unfolds in the boundless expanse of the sky would be forever veiled from their view. For, it appears to be one grand design of the Creator, in giving these bodies a diurnal motion, not only to cheer their inhabitants with light and warmth, and the gay coloring produced by the solar rays; but also to open to them a prospect of other portions of his vast dominions, which are dispersed in endless variety throughout the illimitable regions of space, in order that they may acquire a more sublime impression of the glory of his kingdom, and of his eternal Power and Godhead. But were perpetual day to irradiate the planets, it would throw an eternal and impenetrable veil over the glories of the sky, behind which the magnificent operations of Jehovah's power would be in a great measure concealed. It is this circumstance which we should consider as the principal reason why a rotatory motion has been impressed on the planetary globes; and not merely that a curtain of darkness might be thrown around their inhabitants during the repose of sleep, as in the world in which we dwell. For, in some of the other planetary worlds belonging to our system, the intelligent beings with which they are peopled may stand in no need of that nocturnal repose which is necessary for man; their physical powers may be incapable of being impaired, and their mental energies may be in perpetual exercise. And in

some of those bodies which are surrounded with an assemblage of rings and moons, as the planet Saturn, the diversified grandeur of their celestial phenomena, in the absence of the sun, may present a scene of contemplation and enjoyment far more interesting than all the splendors of their noon-day. Beside, had the planets no motion round their axes, and were both their hemispheres supposed to be peopled with inhabitants, their physical state and enjoyments would be as opposite to each other, as if they lived under the government of two distinct independent beings. While the one class was basking under the splendors of perpetual day, the other would be involved in all the horrors of an everlasting night. While the one hemisphere would be parched with excessive heat, the other would be bound in the fetters of eternal ice; and in such a globe as ours, the motion of the tides, the ascent of the vapors, the currents of the atmosphere, the course of the winds, the benign influences of the rains and dews, and a thousand other movements, which produce so many salutary and beneficial effects, would be completely deranged. Hence we find, that in all the planetary bodies on which spots have been discovered, a rotatory motion actually exists,\* in the secondary as well as in the primary planets, and even in the sun itself, the center and the mover of the whole: in which arrangement of the Almighty Creator, the evidences of wisdom and design are strikingly apparent.

This amazing scene of Divine workmanship and skill which the planetary system exhibits, we have reason to believe is multiplied and diversified to an indefinite extent, throughout all the other systems of creation, displaying to the intelligences of every region "the manifold wisdom of God." For there can be no question, that every star we now behold, either by the naked eye or by the help of a telescope, is the center of a system of planetary worlds, where the agency of God, and his unsearchable wisdom, may be endlessly varied, and perhaps more strikingly displayed than even in the system to which we belong. These vast globes of light could never have been designed merely to shed a few glimmering rays on our far distant world: for the ten thousandth part of them has never yet been seen by the inhabitants of the earth since the Mosaic creation, except by a few astronomers of the past and the present age; and the light of many of them, in all probability, has never yet reached us, and perhaps never will until the period of "the consummation of all terrestrial things." They were not made in vain; for such a supposition would be inconsistent with every idea we can form of the attributes of a Being of infinite perfection. They were not intended merely to diversify the voids of infinite space with a useless splendor which has no relation to intellectual natures: for this would give us a most distorted and inconsistent idea of the character of Him who is "the only-wise God;" and we are told by an authority which cannot be questioned, that "by his wisdom he made the heavens, and stretched them out by his understanding." The only rational conclusion, therefore, which can be deduced, is, that they are destined to distribute illumination and splendor, vivifying influence and happiness,

\* It forms no objection to these remarks, that *caloric*, or the matter of *heat*, does not altogether depend upon the direct influence of the solar rays. The substance of caloric may be chiefly connected with the constitution of the globe we inhabit. But still it is quite certain, that the earth, as presently constituted, would suffer effects most disastrous to sentient beings, were it removed much nearer to, or much farther from the central luminary. Those planets which are removed several hundreds of millions of miles farther from the sun than our globe, may possibly experience a degree of heat much greater than ours; but, in this case the constitution of the solid parts of these globes, and of their surrounding atmospheres, must be very different from what obtains in the physical arrangements of our globe.

\* On the planet *Uranus*, or *Herschel*, no spots or inequalities of surface have been discovered, on account of its great distance from the earth; but spots have been discovered on the planets *Saturn*, *Jupiter*, *Mars*, and *Venus*, by which their diurnal rotations have been ascertained. There can be no doubt, however, that *Uranus* rotates on an axis as well as the other planets, although its distance prevents us from determining this point by actual observation.



among incalculable numbers of intelligent beings, of various degrees of physical, moral, and intellectual excellence. And wherever the Creator has exerted his Almighty energies in the production of sensitive and intellectual natures we may rest assured, that there also his infinite wisdom and intelligence, in an endless variety of arrangements, contrivances, and adaptations, are unceasingly displayed.

But, after all, whatever evidences of contrivance and design the celestial globes may exhibit, it is not in the heavens that the most striking displays of Divine wisdom can be traced by the inhabitants of our world. It is only a few *general relations* and adaptations that can be distinctly perceived among the orbs of the firmament; though, in so far as we are able to trace the purposes which they subserve, the marks of beauty, order, and design, are uniformly apparent. But we are placed at too great a distance from the orbs of heaven, to be able to investigate the particular arrangements which enter into the physical and moral economy of the celestial worlds. Were we transported to the surface of the planet Jupiter, and had an opportunity of surveying, at leisure, the regions of that vast globe, and the tribes of sensitive and intellectual existence which compose its population—of contemplating the relations of its moons to the pleasure and comfort of its inhabitants—the constitution of its atmosphere as to its reflective and refractive powers, in producing a degree of illumination to compensate for the great distance of that planet from the sun—its adaptation to the functions of animal life—the construction of the visual organs of its inhabitants, and the degree of sensibility they possess, corresponding to the quantity of light received from the sun—the temperature of the surface and atmosphere of this globe, corresponding to its distance from the central source of heat, and to the physical constitution of sensitive beings—in short, could we investigate the relations which inanimate nature, in all its varieties and sublimities, bears to the necessities and the happiness of the animated existences that traverse its different regions, we should, doubtless, behold a scene of Divine wisdom and intelligence, far more admirable and astonishing than even that which is exhibited in our sublunary world.—But since it is impossible for us to investigate the economy of other worlds, while we are chained down to this terrestrial sphere, we must direct our attention to those arrangements and contrivances in the constitution of our own globe, which lie open to our particular inspection, in order to perceive more distinctly the benevolent designs of Him “in whom we live, and move, and have our being.” And here an attentive observer will find, in almost every object, when minutely examined, a display of goodness and intelligence, which will constrain him to exclaim, “O the depth of the riches, both of the wisdom and the knowledge of God!”

Wisdom, considered as consisting in contrivance, or the selection of the most proper means in order to accomplish an important end, may be exemplified and illustrated in a variety of familiar objects in the scene of nature.

The earth on which we tread was evidently intended by the Creator to support man and other animals, along with their habitations, and to furnish those vegetable productions which are necessary for their subsistence; and, accordingly, he has given it that exact degree of consistency which is requisite for these purposes. Were it much harder than it now is—were it, for example, as dense as a rock, it would be incapable of cultiva-

tion, and vegetables could not be produced from its surface. Were it softer it would be insufficient to support us, and we should sink at every step, like a person walking in a quagmire. No buildings, such as those we now construct could have been supported, and no conveyances such as coaches and steam-carriages could have moved along its surface. Had this circumstance not been attended to in its formation, the earth would have been rendered useless as a habitable world for all those animated beings which now traverse its different regions. The exact adjustments of the solid parts of the globe to the nature and necessities of the beings which inhabit it, is therefore an instance and an evidence of wisdom.

The diversity of surface which it everywhere presents, in the mountains and vales with which it is variegated, indicates the same benevolent contrivance and design. If the earth were divested of its mountains, and its surface were everywhere uniformly smooth, there would be no rivers, springs, or fountains; for water can flow only from a higher to a lower place; the vegetable tribes would droop and languish; man and other animals would be deprived of what is necessary for their existence and comfort; we should be destitute of many useful stones, minerals, plants, and trees, which are now produced on the surface and in the interior of mountains; the sea itself would become a stagnant marsh, or overflow the land; and the whole surface of nature in our terrestrial sphere would present an unvaried scene of dull uniformity. Those picturesque and sublime scenes which fire the imagination of the poet, and which render mountainous districts so pleasing to the philosophic traveler, would be completely withdrawn; and all around, when compared with such diversified landscapes, would appear as fatiguing to the eye as the vast solitudes of the Arabian deserts, or the dull monotony of the ocean. But, in consequence of the admirable distribution of hills and mountains over the surface of our globe, a variety of useful and ornamental effects is produced. Their lofty summits are destined by Providence to arrest the vapors which float in the regions of the air; their internal cavities form so many spacious basins for the reception of water distilled from the clouds; they are the original sources of springs and rivers, which water and fertilize the earth; they form immense magazines, in which are deposited stones, metals, and minerals, which are of so essential service in the arts that promote the comfort of human life; they serve for the production of a vast variety of herbs and trees; they arrest the progress of storms and tempests; they afford shelter and entertainment to various animals which minister to the wants of mankind; in a word, they adorn and embellish the face of nature—they form thousands of sublime and beautiful landscapes, and afford from their summits the most delightful prospects of the plains below. All these circumstances demonstrate the consummate wisdom of the Great Architect of nature, and lead us to conclude, that mountains, so far from being rude excrescences of nature, as some have asserted, form an essential part of the constitution, not only of our globe, but of all habitable worlds.—And this conclusion is confirmed, so far as our observation extends, with regard to the moon, and several of the planetary bodies which belong to our system, whose surfaces are found to be diversified by sublime ramifications of mountain scenery; which circumstance forms one collateral proof, among many others, that they are the abodes of sentient and intellectual beings.

Again, the *coloring* which is spread over the face of nature indicates the wisdom of the Deity. It is essential to the present mode of our existence, and it was evidently intended by the Creator, that we should be enabled easily to recognize the forms and properties of the various objects with which we are surrounded. But were the objects of nature destitute of color, or were the same unvaried hue spread over the face of creation, we should be destitute of all the entertainments of vision, and be at a loss to distinguish one object from another. We should be unable to distinguish rugged precipices from fruitful hills—naked rocks from human habitations—the trees from the hills that bear them—and the tilled from the untilled lands. “We should hesitate to pronounce whether an adjacent inclosure contains a piece of pasturage, a plot of arable land, or a field of corn; and it would require a little journey, and a minute investigation, to determine such a point. We could not determine whether the first person we met were a soldier in his regimentals, or a swain in his Sunday suit; a bride in her ornaments, or a widow in her weeds.” Such would have been the aspect of nature, and such the inconveniences to which we should have been subjected, had God allowed us light, without the distinction of colors. We could have distinguished objects only by intricate trains of reasoning, and by circumstances of time, place, and relative position. And to what delays and perplexities should we have been reduced, had we been obliged every moment to distinguish one thing from another by reasoning? Our whole life must then have been employed rather in study than in action; and after all, we must have remained in eternal uncertainty as to many things which are now quite obvious to every one as soon as he opens his eyes. We could neither have communicated our thoughts by writing, nor have derived instruction from others through the medium of books; for it is the contrast of different colors which enables us to distinguish the letters, words, and sentences, in a written or printed book—so that we should now have been almost as ignorant of the transactions of past ages, as we are of the events which are passing in the planetary worlds; and, consequently, we could never have enjoyed a written revelation from Heaven, nor any other infallible guide to direct us in the path to happiness, if the Almighty had not distinguished the rays of light, and painted the objects around us with a diversity of colors,—so essentially connected are the minutest and the most magnificent works of Deity. But now, in the present constitution of things, color characterizes the class to which every individual belongs, and indicates, upon the first inspection, its respective quality. Every object wears its peculiar livery, and has a distinguishing mark by which it is characterized.

The different hues which are spread over the scenery of the world are also highly ornamental to the face of nature, and afford a variety of pleasures to the eye and the imagination. It is this circumstance which adds a charm to the fields, the valleys, and the hills, the lofty mountain, the winding river, and the expansive lake; and which gives a splendor and sublimity to the capacious vault of heaven. Color is therefore an essential requisite to every world inhabited by sensitive beings; and we know, that provision has been made for diffusing it throughout all the globes which may exist in the distant regions which our telescopes have penetrated; for the light which radiates from the most distant stars is capable of be-

ing separated into the prismatic colors, similar to those which are produced by the solar rays; which furnishes a presumptive proof, that they are intended to accomplish designs, in their respective spheres, analogous to those which light subserves in our terrestrial habitation,—or, in other words, that they are destined to convey to the minds of sentient beings, impressions of light and color; and consequently, beings susceptible of such impressions must reside within the sphere or more immediate influence of these far distant orbs.

The same benevolent design is apparent in the *general color which prevails throughout the scene of sublunary nature*. Had the fields been clothed with hues of a deep red, or a brilliant white, the eye would have been dazzled with the splendor of their aspect. Had a dark blue or a black color generally prevailed, it would have cast a universal gloom over the face of nature. But an agreeable green holds the medium between these two extremes, equally remote from a dismal gloom and excessive splendor, and bears such a relation to the structure of the eye, that it refreshes instead of tiring it, and supports instead of diminishing its force. At the same time, though one general color prevails over the landscape of the earth, it is diversified by an admirable variety of shades, so that every individual object in the vegetable world can be accurately distinguished from another; thus producing a beautiful and variegated appearance over the whole scenery of nature.—“Who sees not, in all these things, that the hand of the Lord hath wrought this?”

If from the earth we turn our attention to the *waters*, we shall perceive similar traces of the exquisite wisdom and skill of the Author of nature. Water is one of the most essential elementary parts in the constitution of our globe, without which the various tribes of beings which now people it could not exist. It supplies a necessary beverage to man, and to all the animals that people the earth and the air. It forms a solvent for a great variety of solid bodies; it is the element in which an infinitude of organized beings pass their existence; it acts an important part in conveying life and nourishment to all the tribes of the vegetable kingdom, and gives salubrity to the atmospherical regions. Collected in immense masses in the basins of the sea, it serves as a vehicle for ships, and as a medium of communication between people of the most distant lands.—Carried along with a progressive motion over the beds of streams and of rivers, it gives a brisk impulse to the air, and prevents the unwholesome stagnation of vapors; it receives the filth of populous cities, and rids them of a thousand nuisances. By its impulsion, it becomes the mover of a multitude of machines; and, when rarified into steam, it is transformed into one of the most powerful and useful agents under the dominion of man.—All which beneficial effects entirely depend on the exact degree of density, or specific gravity, which the Creator has given to its constituent parts. Had it been much more rarified than it is, it would have been altogether unfit to answer the purposes now specified; the whole face of the earth would have been a dry and barren waste; vegetable nature could not have been nourished; our floating edifices could not have been supported; the lightest bodies would have sunk, and all regular intercourse with distant nations would have been prevented. On the other hand, had its parts been much denser than they are,—for example, had they been of the consistency of a thin jelly, similar disastrous effects would have

inevitably followed; and ships could have plowed the ocean—no refreshing beverage would have been supplied to the animal tribes—the absorbent vessels of trees, herbs, and flowers, would have been unable to imbibe the moisture requisite for their nourishment, and we should thus have been deprived of all the beneficial effects we now derive from the use of that liquid element, and of all the diversified scenery of the vegetable world. But the configuration and consistency of its parts are so nicely adjusted to the constitution of the other elements, and to the wants of the sensitive and vegetable tribes, as exactly to subserve the ends intended in the system of nature.

Water has been ascertained to be a compound body, formed by the union of two different kinds of air—oxygen and hydrogen. It has the property of becoming, in certain cases, much lighter than air; though, in its natural liquid state, it is 800 times heavier than that fluid; and has also the property of afterward resuming its natural weight. Were it not for this property, evaporation could not be produced; and, consequently, no clouds, rain, nor dew could be formed, to water and fertilize the different regions of the earth. But in consequence of this wonderful property, the ocean becomes an inexhaustible cistern to our world. From its expansive surface are exhaled those vapors which supply the rivers and nourish the vegetable productions of every land. “The air and the sun,” says an elegant writer, “constitute the mighty engine which works without intermission to raise the liquid treasure; while the clouds serve as so many aqueducts to convey them along the atmosphere, and distribute them at seasonable periods, and in regular proportions, through all the regions of the globe.”

Notwithstanding the properties now stated, *motion was still requisite*, to insure all the advantages we now derive from the liquid element. Had the whole mass of waters been in a stagnant state, a thousand inconveniences and disastrous consequences would have inevitably ensued. But the All-wise Creator has impressed upon its various masses a circulating motion, which preserves its purity and widely extends its beneficial influence. The hills pour their liquid stores into the rivers; the rivers roll their watery treasures into the ocean; the waters of the ocean, by a libatory motion, roll backward and forward every twelve hours, and by means of currents and the force of winds, are kept in constant agitation. By the solar heat, a portion of these waters is carried up into the atmosphere, and, in the form of clouds, is conveyed by the winds over various regions; until at last it descends in rain and dew, to supply the springs “which run among the hills.” So that there is a constant motion and circulation of the watery element, that it may serve as an agent for carrying forward the various processes of nature, and for ministering to the wants of man and beast.

In fine, were the waters in a state of perpetual stagnation, the filth of populous cities would be accumulated to a most unwholesome degree; the air would be filled with putrid exhalations, and the vegetable tribes would languish and die. Were they deprived of the property of being evaporated (in which state they occupy a space 1600 times greater than in their liquid state), rain and dew could never be produced, and the earth would be turned into “a dry and parched wilderness;” neither grass nor corn could be sufficiently dried to lay up for use; *our clothes, when washed, could never be dried*; and a variety of common operations which now conduce to our convenience and

comfort, could never be carried on. But the infinite wisdom of the Creator, foreseeing all the effects which can possibly arise from these principles of nature, has effectually provided against such disasters, by arranging all things in number, weight, and measure, to subserve the beneficial ends for which they were ordained. “He causeth the vapors to ascend from the ends of the earth;” “he sendeth the springs into the valleys, which run among the hills. They give drink to every beast of the field; the wild asses quench their thirst. By them the fowls of heaven have their habitation, which sing among the branches. He watereth the hills from his chambers: the earth is satisfied with the fruit of his works.”

Let us now attend to the *atmosphere*, in the constitution of which the wisdom of God is no less conspicuous than in the other departments of nature.

The atmosphere is one of the most essential appendages of the globe we inhabit, and exhibits a most striking scene of Divine skill and omnipotence. The term *atmosphere* is applied to the whole mass of fluids, consisting of air, vapors, electric fluid, and other matters, which surround the earth to a certain height. This mass of fluid matter gravitates to the earth, revolves with it in its diurnal rotation, and is carried along with it in its course round the sun every year. It has been computed to extend about 45 miles above the earth's surface, and it presses on the earth with a force proportioned to its height and density. From experiments made by the barometer, it has been ascertained that it presses with a weight of about 15 pounds on every square inch of the earth's surface; and, therefore, its pressure on the body of a middle-sized man is equal to about 32,000 pounds, or 14 tons avoirdupois, a pressure which would be insupportable, and even fatal, were it not equal in every part, and counterbalanced by the spring of the air within us. The pressure of the whole atmosphere upon the earth is computed to be equivalent to that of a globe of lead 60 miles in diameter, or about 5,900,000,000,000,000 tons; that is, the whole mass of air which surrounds the globe compresses the earth with a force or power equal to that of *five thousand millions of millions of tons*.\* This amazing pressure is, however, essentially necessary for the preservation of the present constitution of our globe, and of the animated beings which dwell on its surface. It prevents the heat of the sun from converting water, and all other fluids on the face of the earth, into vapor; and preserves the vessels of all organized beings in due tone and vigor. Were the atmospherical pressure entirely removed, the elastic fluids contained in the finer vessels of men and other animals, would inevitably burst them, and life would become extinct; †

\* See Appendix, Note II.

† The necessity of the atmospherical pressure, for the comfort and preservation of animal life, might be illustrated by the effects experienced by those who have ascended to the summits of very high mountains, or who have been carried to a great height above the surface of the earth in balloons. Acosta, in his relation of a journey among the mountains of Peru, states that “he and his companions were surprised with such extreme pangs of straining and vomiting, not without casting up of blood too, and with so violent a distemper, that they would undoubtedly have died had they remained two or three hours longer in that elevated situation.” Count Zambecchi and his companions, who ascended in a balloon on the 7th of November, 1783, to a great height, found their hands and feet so swelled, that it was necessary for a surgeon to make incisions in the skin. In both the cases now stated, the persons ascended to so great a height that the pressure of the atmosphere was not sufficient to counterbalance the pressure of the fluids of the body.

and most of the substances on the face of the earth, particularly liquids, would be dissipated into vapor.

The atmosphere is now ascertained to be a compound substance, formed of two very different ingredients, termed *oxygen gas* and *nitrogen gas*. Of 100 measures of atmospheric air, 21 are oxygen, and 79 nitrogen. The one, namely, oxygen, is the principle of combustion and the vehicle of heat, and is absolutely necessary for the support of animal life, and is the most powerful and energetic agent in nature; the other is altogether incapable of supporting either flame or animal life. Were we to breathe oxygen air, without any mixture or alloy, our animal spirits would be raised, and the fluids in our bodies would circulate with greater rapidity; but we would soon infallibly perish by the rapid and unnatural accumulation of heat in the animal frame. If the nitrogen were extracted from the air, and the whole atmosphere contained nothing but oxygen or vital air, combustion would not proceed in that gradual manner which it now does, but with the most dreadful and irresistible rapidity: not only wood and coals, and other substances now used for fuel, but even stones, iron, and other metallic substances, would blaze with a rapidity which would carry destruction through the whole expanse of nature. If even the proportions of the two airs were materially altered, a variety of pernicious effects would instantly be produced. If the oxygen were less in quantity than it now is, fire would lose its strength, candles would not diffuse a sufficient light, and animals would perform their vital functions with the utmost difficulty and pain. On the other hand, were the nitrogen diminished and the oxygen increased, the air taken in by respiration would be more stimulant, and the circulation of the animal fluids would become accelerated; but the tone of the vessels thus stimulated to increased action, would be destroyed by too great an excitement, and the body would inevitably waste and decay. Again, were the oxygen completely extracted from the atmosphere, and nothing but nitrogen to remain, fire and flame would be extinguished, and instant destruction would be carried throughout all the departments of vegetable and animated nature. For a lighted taper will not burn for a single moment in nitrogen gas, and if an animal be plunged into it, it is instantly suffocated.

Again, not only the extraction of any one of the component parts of the atmosphere, or the alteration of their respective proportions, but even the slightest increase or diminution of their *specific gravity*, would be attended with the most disastrous effects. The nitrogen is found to be a little lighter than common air, which enables it to rise toward the higher regions of the atmosphere. In breathing, the air which is evolved from the lungs, at every expiration, consists chiefly of nitrogen, which is entirely unfit to be breathed again, and therefore rises above our heads before the next inspiration. Now, had nitrogen, instead of being a little lighter, been a slight degree heavier than common air, or of the same specific gravity, it would have accumulated on the surface of the earth, and particularly in our apartments, to such a degree as to have produced diseases, pestilence, and death, in rapid succession. But being a little lighter than the surrounding air, it flies upward, and we never breathe it again, until it enters into new and salutary combinations. Such is the benevolent skill which the Author of Nature has displayed, for

promoting the comfort and preservation "of everything that lives."\*

Further, *were the air colored*, or were its particles much larger than they are, we could never obtain a distinct view of any other object. The exhalations which rise from the earth, being rendered visible, would disfigure the rich landscape of the universe, and render life disagreeable. But the Almighty by rendering the air invisible, has enabled us not only to take a delightful and distinct survey of the objects that surround us, but has veiled from our view the gross humors incessantly perspired from animal bodies, the filth exhaled from kitchens, streets, and sewers, and every other object that would excite disgust. Again, *were the different portions of the atmosphere completely stationary*, and not susceptible of agitation, all nature would soon be thrown into confusion. The vapors which are exhaled from the sea by the heat of the sun, would be suspended, and remain forever fixed over those places from whence they arose. For want of this agitation of the air, which now scatters and disperses the clouds over every region, the sun would constantly scorch some districts, and be forever hid from others; the balance of nature would be destroyed; navigation, as it has hitherto been carried on by the agency of winds, would be useless, and we could no longer enjoy the productions of different climates. In fine, were the atmosphere capable of being frozen, or converted into a solid mass, as all other fluids are (and we know no reason why it should not be subject to congelation but the will of the Creator), the lives of every animal in the air, the waters, and the earth, would, in a few moments, be completely extinguished. But the admirable adjustment of every circumstance, in relation to this useful element, produces all the beneficial effects which we now experience, and strikingly demonstrates, that the Intelligent Contriver of all things is "wonderful in counsel, and excellent in working."

From the instances now stated, we may plainly perceive, that if the Almighty had not a particular regard to the happiness of his intelligent offspring, and to the comfort of every animated existence, or, if he wished to inflict summary punishment on a wicked world, he could easily effect, by a very slight change in the constitution of the atmosphere, the entire destruction of the human race, and the entire conflagration of the great globe they inhabit,—throughout all its elementary regions. He has only to extract one of its constituent parts,—the nitrogen from the oxygen gas,—and the grand catastrophe is at once accomplished. With what a striking propriety and emphasis, then, do the inspired writers declare, that "in Him we live, and move, and have our being;" and that "in His hand is the soul

\* The necessity of atmospherical air for the support of life was strikingly exemplified in the fate of the unhappy men who died in the *Black-hole* of Calcutta. On the 20th of June, 1756, about eight o'clock in the evening, 146 men were forced, at the point of the bayonet, into a dungeon only 18 feet square. They had been but a few minutes confined in this infernal prison, before every one fell into a perspiration so profuse, that no idea can be formed of it. This brought on a raging thirst, the most difficult respiration, and an outrageous delirium. Such was the horror of their situation, that every insult that could be devised against the guard without, and all the opprobrious names that the Viceroy and his officers could be loaded with, were repeated, to provoke the guard to fire upon them, and terminate their sufferings. Before eleven o'clock the same evening, one-third of the men were dead; and before six next morning, only 23 came out alive, but most of them in a high putrid fever. All these dreadful effects were occasioned by the want of atmospherical air, and by their breathing a superabundant quantity of the nitrogen emitted from their lungs.

of every living thing, and the breath of all mankind."

A great variety of other admirable properties is possessed by the atmosphere, of which I shall briefly notice only the following:—It is the vehicle of *smells*, by which we become acquainted with the qualities of the food which is set before us, and learn to avoid those places which are damp, unwholesome, and dangerous. It is the medium of *sounds*, by means of which knowledge is conveyed to our minds. Its undulations, like so many couriers, run forever backward and forward, to convey our thoughts to others, and theirs to us; and to bring news of transactions which frequently occur at a considerable distance. A few strokes on a large bell, through the ministration of the air, will convey signals of distress, or of joy, in a quarter of a minute, to the population of a city containing a hundred thousand inhabitants. So that the air may be considered as the conveyer of the thoughts of mankind, which are the cement of society. It transmits to our ears all the harmonies of music, and expresses every passion of the soul; it swells the notes of the nightingale, and distributes alike to every ear the pleasures which arise from the harmonious sounds of a concert. It produces the blue color of the sky, and is the cause of the morning and evening twilight, by its property of bending the rays of light, and reflecting them in all directions. It forms an essential requisite for carrying on all the processes of the vegetable kingdom, and serves for the production of clouds, rain, and dew, which nourish and fertilize the earth. In short, it would be impossible to enumerate all the advantages we derive from this noble appendage to our world. Were the earth divested of its atmosphere, or were only two or three of its properties changed or destroyed, it would be left altogether unfit for the habitation of sentient beings. Were it divested of its undulating quality, we should be deprived of all the advantages of speech and conversation—of all the melody of the feathered songsters, and of all the pleasures of music: and, like the deaf and dumb, we could have no power of communicating our thoughts but by visible signs. Were it deprived of its reflective powers, the sun would appear in one part of the sky in dazzling brightness, while all around would appear as dark as midnight, and the stars would be visible at noon-day. Were it deprived of its refractive powers, instead of the gradual approach of the day and the night, which we now experience—at sunrise, we should be transported all at once from midnight darkness to the splendor of noon-day: and, at sunset, should make as sudden a transition from the splendors of day to all the horrors of midnight, which would bewilder the traveler in his journey, and strike the creation with amazement. In fine, were the oxygen of the atmosphere completely extracted, destruction would seize on all the tribes of the living world throughout every region of earth, air, and sea.

Omitting, at present, the consideration of an indefinite variety of other particulars, which suggest themselves on this subject, I shall just notice one circumstance more, which has a relation both to the waters and to the atmosphere. It is a well known law of nature, that all bodies are expanded by heat, and contracted by cold. There is only one exception to this law which exists in the economy of our globe, and that is, the *expansion of water in the act of freezing*. While the parts of every other body are reduced in bulk, and their specific gravity increased by the application of cold; water, on the contrary, when congealed

into ice, is increased in bulk, and becomes of a less specific gravity than the surrounding water and, therefore, swims upon its surface. Now had the case been otherwise; had water, when deprived of a portion of its heat, followed the general law of nature, and, like all other bodies, become specifically heavier than it was before, the present constitution of nature would have been materially deranged, and many of our present comforts and even our very existence, would have been endangered. At whatever time the temperature of the atmosphere became reduced to 32° of the common thermometer, or to what is called the freezing point, the water on the surface of our rivers and lakes would have been converted into a layer of ice; this layer would have sunk to the bottom as it froze; another layer of ice would have been immediately produced, which would also have sunk to the former layer, and so on in succession, until in the course of time all our rivers from the surface to the bottom, and every other portion of water capable of being frozen, would have been converted into solid masses of ice, which all the heat of summer could never have melted. We should have been deprived of most of the advantages we now derive from the liquid element, and in a short time, the face of nature would have been transformed into a frozen chaos. But in the existing constitution of things, all such dismal effects are prevented, in consequence of the Creator having subjected the waters to a law contrary to that of other fluids, by means of which the frozen water swims upon the surface, and preserves the cold from penetrating to any great depth in the subjacent fluid; and when the heat of the atmosphere is increased, it is exposed to its genial influence, and is quickly changed into its former liquid state. How admirably, then, does this *exception* to the general law of nature display the infinite intelligence of the Great Contriver of all things, and his providential care for the comfort of his creatures, when he arranged and established the economy of nature.

#### VARIETY OF NATURE.

As a striking evidence of Divine Intelligence, we may next consider the *immense variety which the Creator has introduced into every department of the material world*.

In every region on the surface of the globe, an endless multiplicity of objects, all differing from one another in shape, color, and motion, present themselves to the view of the beholder. Mountains covered with forests, hills clothed with verdure, spacious plains adorned with vineyards, orchards, and waving grain; naked rocks, abrupt precipices, extended vales, deep dells, meandering rivers, roaring cataracts, brooks and rills, lakes and gulfs, bays and promontories, seas and oceans, caverns and grottoes—meet the eye of the student of Nature, in every country, with a variety which is at once beautiful and majestic. Nothing can exceed the variety of the *vegetable kingdom*, which pervades all climates, and almost every portion of the dry land, and of the bed of the ocean. The immense collections of Natural History which are to be seen in the Museum at Paris show, that botanists are already acquainted with nearly fifty-six thousand different species of plants.\* And yet, it is probable, that these form but a very small portion of what actually exists, and that several hundreds of thousands of species remain to be explored by the industry of future ages: for

\* Edinburgh Philosophical Journal, July, 1822, p. 48.

by far the greater part of the vegetable world still remains to be surveyed by the scientific botanist. Of the numerous tribes of vegetable nature which flourish in the interior of Africa and America, in the immense islands of New Holland, New Guinea, Borneo, Sumatra, Java, Ceylon, Madagascar, and Japan; in the vast regions of Tartary, Thibet, Siberia, and the Birman empire, in the Philippines, the Moluccas, the Ladrões, the Carolinas, the Marquesas, the Society, the Georgian, and in thousands of other islands which are scattered over the Indian and Pacific oceans—little or nothing is known by the Naturalists of Europe; and yet it is a fact which admits of no dispute that every country hitherto explored produces a variety of species of plants peculiar to itself; and those districts in Europe which have been frequently surveyed, present to every succeeding explorer a new field of investigation, and reward his industry with new discoveries of the beauties and varieties of the vegetable kingdom. It has been conjectured by some Naturalists, on the ground of a multitude of observations, that “there is not a square league of earth, but what presents some one plant peculiar to itself, or, at least, which thrives there better, or appears more beautiful, than in any other part of the world.” This would make the number of species of vegetables to amount to as many millions as there are of square leagues on the surface of the earth—that is, to more than twenty-one millions.

Now every one of these species of plants differs from another, in its size, structure, form, flowers, leaves, fruits, mode of propagation, color, medicinal virtues, nutritious qualities, internal vessels, and the odors it exhales. They are of all sizes, from the microscopic mushroom, invisible to the naked eye, to the sturdy oak and the cedar of Lebanon, and from the slender willow to the Banian tree, under whose shade 7000 persons may find ample room to repose. A thousand different shades of color distinguish the different species. Every one wears its peculiar livery, and is distinguished by its own native hues; and many of their inherent beauties can be distinguished only by the help of the microscope. Some grow upright, others creep along in a serpentine form. Some flourish for ages, others wither and decay in a few months; some spring up in moist, others in dry soils; some turn toward the sun, others shrink and contract when we approach to touch them. Not only are the different species of plants and flowers distinguished from each other by their different forms, but even the different individuals of the same species. In a bed of tulips or carnations, for example, there is scarcely a flower in which some difference may not be observed in its structure, size, or assemblage of colors; nor can any two flowers be found in which the shape and shades are exactly similar. Of all the hundred thousand millions of plants, trees, herbs, and flowers, with which our globe is variegated, there are not, perhaps, two individuals precisely alike, in every point of view in which they may be contemplated; yea, there is not, perhaps, a single leaf in the forest, when minutely examined, that will not be found to differ, in certain aspects, from its fellows. Such is the wonderful and infinite diversity with which the Creator has adorned the vegetable kingdom.

His wisdom is also evidently displayed in this vast profusion of vegetable nature—in adapting each plant to the soil and situation in which it is destined to flourish—in furnishing it with those vessels by which it absorbs the air and moisture on which it feeds—and in adapting it to the na-

ture and necessities of animated beings. As the earth teems with animated existence, and as the different tribes of animals depend chiefly on the productions of the vegetable kingdom for their subsistence, so there is an abundance and a variety of plants adapted to the peculiar constitution of every individual species. This circumstance demonstrates, that there is a preconcerted relation and fitness between the internal constitution of the animal, and the nature of the plants which afford it nourishment; and shows us that the animal and the vegetable kingdoms are the workmanship of one and the same Almighty Being, and that, in his arrangements with regard to the one, he had in view the necessities of the other.

When we direct our attention to the tribes of animated nature, we behold a scene no less variegated and astonishing. Above fifty thousand species of animals have been detected and described by Naturalists, beside several thousands of species which the naked eye cannot discern, and which people the invisible regions of the waters and the air. And as the greater part of the globe has never yet been thoroughly explored, several hundreds, if not thousands, of species unknown to the scientific world, may exist in the depths of the ocean, and in the unexplored regions of the land. All these species differ from one another in color, size, and shape; in the internal structure of their bodies, in the number of their sensitive organs, limbs, feet, joints, claws, wings, and fins; in their dispositions, faculties, movements, and modes of subsistence. They are of all sizes, from the mite and the gnat up to the elephant and the whale, and from the mite downward to those invisible animalcules, a hundred thousand of which would not equal a grain of sand. Some fly through the atmosphere, some glide through the waters, others traverse the solid land. Some walk on two, some on four, some on twenty, and some on a hundred feet. Some have eyes furnished with two, some with eight, some with a hundred, and some with eight thousand distinct transparent globes, for the purposes of vision.\*

Our astonishment at the variety which appears in the animal kingdom is still further increased, when we consider not only the diversities which

\* The eyes of beetles, silk-worms, flies, and several other kinds of insects, are among the most curious and wonderful productions of the God of nature. On the head of a fly are two large protuberances, one on each side; these constitute its organs of vision. The whole surface of these protuberances is covered with a multitude of small hemispheres, placed with the utmost regularity in rows, crossing each other in a kind of lattice-work. These little hemispheres have each of them a minute transparent convex lens in the middle, each of which has a distinct branch of the optic nerve ministering to it; so that the different lenses may be considered as so many distinct eyes. Mr. Leewenhoek counted 6276 in the two eyes of a silk-worm, when in its fly state; 3160 in each eye of a beetle; and 4600 in the two eyes of the common fly. Mr. Hooke reckoned 14,600 in the eyes of a drone fly; and, in one of the eyes of a dragon fly, there have been reckoned 13,500 of these lenses, and consequently, in both eyes 27,000, every one of which is capable of forming a distinct image of any object, in the same manner as a common convex glass; so that there are twenty seven thousand images formed on the retina of this little animal. Mr. Leewenhoek having prepared the eye of a fly for that purpose, placed it a little farther from his microscope than when he would examine an object, so as to leave a proper focal distance between it and the lens of his microscope; and then looked through both, in the manner of a telescope, at the steeple of a church, which was 299 feet high, and 750 feet distant, and could plainly see, through every little lens, the whole steeple inverted, though not larger than the point of a fine needle; and then directing it to a neighboring house, saw through many of these little hemispheres, not only the front of the house, but also the doors and windows, and could discern distinctly whether the windows were open or shut—such an exquisite piece of Divine mechanism transcends all human comprehension.

are apparent in their external aspect, but also in their internal structure and organization. When we reflect on the thousands of movements, adjustments, adaptations, and compensations, which are requisite in order to the construction of an animal system, for enabling it to perform its intended functions;—when we consider, that every species of animals has a system of organization peculiar to itself, consisting of bones, joints, blood-vessels, and muscular motions, differing in a variety of respects from those of any other species, and exactly adapted to its various necessities and modes of existence;—and when we consider still further, the incomprehensibly delicate contrivances, and exquisite borings, polishings, clasplings, and adaptations, which enter into the organization of an animated being ten thousand times less than a mite; and that the different species of these animals are likewise all differently organized from one another,—we cannot but be struck with reverence and astonishment at the *Intelligence* of that Incomprehensible Being who arranged the organs of all the tribes of animated nature, “who breathed into them the breath of life,” and who continually upholds them in all their movements!

Could we descend into the subterraneous apartments of the globe, and penetrate into those unknown recesses which lie toward its center, we should doubtless behold a variegated scene of wonders, even in those dark and impenetrable regions. But all the labor and industry of man have not hitherto enabled him to penetrate farther into the bowels of the earth than the six-thousandth part of its diameter, or, about a mile and a quarter; so that we must remain forever ignorant of the immense caverns and masses of matter that may exist, and of the processes that may be going on, about its central regions. In those regions, however, near the surface, which lie within the sphere of human inspection, we perceive a variety analogous to that which is displayed in the other departments of nature. Here we find substances of various kinds formed into strata, or layers of different depths—earths, sand, gravel, marl, clay, sandstone, freestone, marble, limestone, coals, peat, and similar materials. In these strata are found metals and minerals of various descriptions—salt, nitrate of potash, ammonia, sulphur, bitumen, platina, gold, silver, mercury, iron, lead, tin, copper, zinc, nickel, manganese, cobalt, antimony, the diamond, rubies, sapphires, jaspers, emeralds, and a countless variety of other substances, of incalculable benefit to mankind. Some of these substances are so essentially requisite for the comfort of man, that without them he would soon degenerate into the savage state, and be deprived of all those arts which extend his knowledge, and which cheer and embellish the abodes of civilized life.

If we turn our eyes upward to the regions of the atmosphere, we may also behold a spectacle of variegated magnificence. Sometimes the sky is covered with sable clouds, or obscured with mists; at other times it is tinged with a variety of hues, by the rays of the rising or the setting sun. Sometimes it presents a pure azure, at other times it is diversified with strata of dappled clouds. At one time we behold the rainbow rearing its majestic arch, adorned with all the colors of light; at another, the Aurora Borealis illuminating the sky with its fantastic coruscations. At one time we behold the fiery meteor sweeping through the air, diffusing a sparkling and brilliant light; at another, we perceive the forked lightning darting from the clouds, and hear the thunders rolling

through the sky. Sometimes the vault of heaven appears like a boundless desert, particularly about the time of the rising and setting of the sun in a clear sky; and at other times adorned with an innumerable host of stars, the blazing comet, the planets in their courses, and with the moon “walking in brightness.” In short, whether we direct our view to the vegetable or the animal tribes—to the atmosphere, the ocean, the mountains, the plains, or the subterranean recesses of the globe, we behold a scene of beauty, order, and *variety*, which astonishes and enraptures the contemplative mind, and constrains us to join in the devout exclamations of the Psalmist, “*How manifold are thy works, O Lord! In wisdom hath thou made them all: the earth is full of thy riches; so is the great and wide sea, wherein are things creeping innumerable, both small and great beasts.*”

This countless variety of objects which appears throughout every department of our sublunary system, not only displays the depths of Divine Wisdom, but also presents us with a faint idea of the *infinity* of the Creator, and of the *immense multiplicity of ideas and conceptions* which must have existed in the Eternal Mind, when the fabric of our globe, and its numerous tribes of inhabitants, were arranged and brought into existence. And if every other world which floats in the immensity of space, be diversified with a similar variety of existences, altogether different from ours (as we have reason to believe, from the variety we already perceive, and from the boundless plans and conceptions of the Creator), the human mind is lost and confounded, when it attempts to form an idea of those endlessly diversified plans, conceptions, and views, which must have existed during an eternity past in the Divine Mind. When we would attempt to enter into the conception of so vast and varied operations, we feel our own littleness, and the narrow limits of our feeble powers, and can only exclaim, with the apostle Paul, “O the depth of the riches both of the wisdom and knowledge of God! how unsearchable are his counsels, and his ways (of creation and providence) past finding out!”

This characteristic of variety, which is stamped on all the works of Omnipotence, is doubtless intended to gratify the principle of curiosity, and the love of novelty, which are implanted in the human breast; and thus to excite rational beings to the study and investigation of the works of the Creator; that therein they may behold the glory of the Divine character, and be stimulated to the exercise of love, admiration, and reverence. For, as the records of Revelation and the dispensations of Providence, display to us the various aspects of the moral character of Deity, so the diversified phenomena, and the multiplicity of objects and operations which the scenery of nature exhibits, present to us a specimen of the *ideas*, as it were, of the Eternal Mind, in so far as they can be adumbrated by material objects, and exhibited to mortals, through the medium of corporeal organs.

To convey an adequate conception of the *number* of these ideas, as exhibited on the globe on which we live, would baffle the arithmetician's skill, and set his numbers at defiance. We may, however, assist our conceptions a little by confining our attention to one department of nature; for example, the ANIMAL KINGDOM. The number of the different species of animals, taking into account those which are hitherto undiscovered, and those which are invisible to the naked eye, cannot be estimated at less than 300,000. In a human body there are reckoned about 446 muscles, in each of which, according to anatomists, there

are at least ten several intentions or due qualifications to be observed—its proper figure, its just magnitude, the right disposition of its several ends, upper and lower, the position of the whole, the insertion of its proper nerves, veins, arteries, etc., so that, in the muscular system alone, there are 460 several ends or aims to be attended to.—The bones are reckoned to be in number about 245, and the distinct scopes or intentions of each of these are above 40; in all, about 9800; so that the system of bones and muscles alone, without taking any other parts into consideration, amounts to above 14,000 different intentions or adaptations. If now we suppose, that all the species of animals above stated are differently constructed, and taken one with another, contain, at an average, a system of bones and muscles as numerous as in the human body—the number of species must be multiplied by the number of different aims and adaptations, and the product will amount to 4,200,000,000. If we were next to attend to the many thousands of blood vessels in an animal body, and the numerous ligaments, membranes, humors, and fluids of various descriptions, the skin with its millions of pores, and every other part of an organical system, with the aims and intentions of each, we should have another sum of many hundreds of millions to be multiplied by the former product, in order to express the diversified ideas which enter into the construction of the animal world. And if we still further consider that, of the hundreds of millions of individuals belonging to each species, no two individuals exactly resemble each other—that all the myriads of vegetables with which the earth is covered are distinguished from each other by some one characteristic or another, and that every grain of sand contained in the mountains, and in the bed of the ocean, as shown by the microscope, discovers a different form and configuration from another—we are here presented with an *image* of the *infinity* of the *conceptions* of Him in whose incomprehensible mind they all existed, during countless ages, before the universe was formed.

To overlook this amazing scene of Divine intelligence, or to consider it as beneath our notice, as some have done—if it be not the characteristic of impiety, is, at least, the mark of a weak and undiscriminating mind. That man who disregards the visible displays of Infinite Wisdom, or who neglects to investigate them when opportunity offers, acts as if he considered himself already possessed of a sufficient portion of intelligence, and stood in no need of such sensible assistance to direct his conceptions of the Creator. Pride, and false conceptions of the nature and design of true religion, frequently lie at the foundation of all that indifference and neglect with which the visible works of God are treated by those who make pretensions to a high degree of spiritual attainments. The truly pious man will trace, with wonder and delight, the footsteps of his Father and his God, wherever they appear in the variegated scene of creation around him, and will be filled with sorrow and contrition of heart, that, amidst his excursions and solitary walks, he has so often disregarded "the works of the Lord, and the operation of his hands."

In fine, the variety which appears on the face of nature not only enlarges our conceptions of Infinite Wisdom, but is also the foundation of all our discriminations and judgments as rational beings, and is of the most essential utility in the affairs of human society. Such is the variety of which the features of the human countenance are susceptible, that it is probable, that no two indi-

viduals, of all the millions of the race of Adam that have existed since the beginning of time, would be found to resemble each other. We know no two human beings presently existing, however similar to each other, but may be distinguished either by their stature, their forms, or the features of their faces; and on the ground of this dissimilarity, the various wheels of the machine of society move onward, without clashing or confusion. Had it been otherwise—had the faces of men, and their organs of speech, been cast exactly in the same mold, as would have been the case had the world been framed according to the Epicurean system, by blind chance directing a course of atoms, it might have been as difficult to distinguish one human countenance from another, as to distinguish the eggs laid by the same hen, or the drops of water which trickle from the same orifice; and consequently, society would have been thrown into a state of universal anarchy and confusion. Friends would not have been distinguished from enemies, villains from the good and honest, fathers from sons, the culprit from the innocent person, nor the branches of the same family from one another. And what a scene of perpetual confusion and disturbance would thus have been created. Frauds, thefts, robberies, murders, assassinations, forgeries, and injustice of all kinds, might have been daily committed without the least possibility of detection. Nay, were even the *variety of tones* in the human voice, peculiar to each person, to cease, and the *handwriting* of all men to become perfectly uniform, a multitude of distressing deceptions and perplexities would be produced in the domestic, civil, and commercial transactions of mankind. But the All-wise and Beneficent Creator has prevented all such evils and inconveniences by the character of *variety* which he has impressed on the human species, and on all his works. By the peculiar features of his countenance, every man may be distinguished in the light; by the tones of his voice he may be recognized in the dark, or when he is separated from his fellows by an impenetrable partition; and his handwriting can attest his existence and individuality, when continents and oceans interpose between him and his relations, and be a witness of his sentiments and purposes to future generations.

Thus I have taken a very cursory view of some evidences of Divine Wisdom, which appear in the general constitution of the *earth*, the *waters*, and the *atmosphere*, and in the characteristic of *variety*, which is impressed on all the objects of the visible creation. When these, and other admirable arrangements in our sublunary system, are seriously contemplated, every rational and pious mind will be disposed to exclaim with the Psalmist—"There is none like unto thee, O Lord, neither are there any works like unto thy works."—"Thou art great, and dost wonderful things: thou art God alone."—"O that men would praise the Lord for his goodness, and for his wonderful works toward the children of men!"

When we consider not only the *utility*, but the *beauty* and *grandeur* of the wise arrangements of nature, what reason have we to admire and adore the goodness of the great Author of our existence! Were all the diversities of shape and color, of mountains and vales, of rivers and lakes, of light and shade, which now embellish the various landscapes of the world, to disappear, and were one unvaried scene perpetually to present itself to the eye, how dull, and wearisome, and uninteresting



would the aspect of the universe appear to an intelligent mind! Although the variegated beauties which adorn the surface of our globe, and the vault of heaven, are not essential to our existence as sensitive beings, yet were they completely withdrawn, and nothing presented to the eye but a boundless expanse of barren sands, the mind would recoil upon itself, its activity would be destroyed, its powers would be confined, as it were, to a prison, and it would roam in vain amidst the surrounding waste in search of enjoyment. Even the luxuries of a palace, were it possible to procure them amidst such a scene of desolation, would become stale and insipid, and would leave the rational soul almost destitute of ideas and of mental energy, to the tiresome round of a cheerless existence. But, in the actual state of the world we live in, there is no landscape in nature, from the icebergs of Greenland to the verdant scenes of the Torrid Zone, in which objects, either of sublimity or of beauty, in boundless variety, are not presented to the view, in order to stimulate the mind to activity, to gratify its desire of novelty, and to elevate its conceptions of the Beneficent Creator.

And if the present constitution of our world displays so evident marks of beauty and benevolent design, now that it is inhabited by an assemblage of depraved intelligences, and its physical aspect deformed, in consequence of "the wickedness of man," what transporting beauties and sublimities must it have presented, when it appeared fresh from the hand of its Almighty Maker, and when all things were pronounced by him to be very good! After a deluge of waters has swept away many of its primeval beauties, and has broken and deranged even its subterraneous strata, this terrestrial world still presents to the eye a striking scene of beauty, order, and beneficence. But we have the strongest reason to believe, that, before sin had disfigured the aspect of this lower world, all was "beauty to the eye, and music to the ear"—that "immortality breathed in the winds, flowed in the rivers," and exhaled from every plant and flower. No storms disturbed the tranquility of nature, nor created the least alarm in the breasts of its holy inhabitants. No earthquakes shook the ground, nor rent the foundations of nature. No volcanoes vomited their rivers of lava, nor overwhelmed the plains with deluges of fire. No barren deserts of heath and sand disfigured the rich landscape of the world—no tempests nor hurricanes tossed the ocean, nor scorching heats nor piercing colds, nor pestilence nor disease, annoyed the human frame. In the paradisaical state of the world, we may reasonably suppose, that all the elements of nature contributed directly to the pleasure and enjoyment of man, and of the other tribes of animated nature; and that they were not subjected as they now are, to the operation of those natural agents which so frequently spread destruction and ruin among the abodes of men. To suppose the contrary to have happened would be inconsistent with the state of pure and happy intelligences, and with the benignity of the Creator; and would imply, that God was either unwilling or unable to remove such physical evils. But we cannot suppose it beyond the limits of Infinite Wisdom and Omnipotence, to create and arrange a world entirely free from those evils and inconveniences which now flow from the operation of certain physical agents, without, at the same time, supposing that his power and intelligence are confined within certain bounds, beyond which they cannot pass. And, therefore, if, in the existing

constitution of things, the harmony of nature is occasionally disturbed, and its beauty defaced, by earthquakes, storms, and tempests—we must remember, that the inhabitants of the earth are now a depraved race of mortals, no longer adorned with primeval purity and innocence; and that the physical economy of our globe has undergone a certain derangement, corresponding to the *moral state* of its present occupants.—But since this earth, even in its present state of degradation and derangement, presents to the view of every beholder so many objects of beauty and magnificence, and so numerous traces of Divine Beneficence—we may reasonably conclude, that scenes of Divine Wisdom and Goodness, far more glorious and transporting, must be displayed in those worlds where moral evil has never shed its malign influence, and where the inhabitants—superior to disease and death—bask forever in the regions of immortality. And therefore, however admirable the displays of Divine Wisdom may appear in the sublunary scene around us, they must be considered as inferior to those which are exhibited in many other provinces of Jehovah's empire, in so far as they are blended with those physical derangements which indicate his displeasure against the sins of men.

Were we now to direct our attention to the mechanism of animated beings; and to consider the numberless contrivances and adaptations in their organical structure and functions, a thousand instances of exquisite wisdom and design, still more striking and admirable, would crowd upon our view. For, although the general fabric of the world, and the immense variety of objects it contains, are evident proofs of a Wise and Intelligent Contriver, yet it is chiefly in the minute and delicate contrivances of organical structures, their adaptation to the purposes of life, motion, and enjoyment, and their relation and correspondence to the surrounding elements, that the consummate skill of the Great Architect of nature is most strikingly perceived. But as it forms no part of my present plan to enter on so extensive a field of illustration, on which volumes might be written, I shall content myself with merely stating an example or two. My first example shall be taken from

#### THE STRUCTURE OF THE HUMAN EYE.

The eye is one of the nicest pieces of mechanism which the human understanding can contemplate; but as it requires a knowledge of its anatomical structure, and of the principles of optics, to enable us to appreciate its admirable functions, I shall confine myself to a few *general* descriptions and remarks.

The eye is nearly of a globular form. It consists chiefly of three coats and three humors. The first or outer coat is termed *sclerotica*; it is everywhere white and opaque, and is joined, at its anterior edge, to another which has more convexity than any other part of the globe of the eye, and, being exceedingly transparent, is called the *cornea*. These two parts are perfectly different in their structure, and are supposed, by some anatomists, to be as distinct from each other as the glass of a watch is from the case into which it is affixed.—Next within this coat is that called the *choroides*, on account of its being furnished with a great number of vessels. It serves, as it were, for a lining to the other, and is joined with that part of the eye termed the *iris*. The *iris* is an opaque

membrane like the choroides, but of different colors in different eyes, as gray, black, or hazel. It is composed of two sets of muscular fibers, the one of a circular form, which contracts the hole in the middle, called the *pupil*, when the light is too strong for the eye; and the other of radial fibers, tending everywhere from the circumference of the iris toward the middle of the pupil; which fibers, by their contractions, dilate and enlarge the pupil, when the light is weak, in order to let in more of its rays.—The third coat is called the *retina*, upon which are painted the images of all visible objects, by the rays of light which flow from them. It spreads like network all over the inside of the choroides, and is nothing more than a fine expansion of the optic nerve; by which nerve the impressions of visible objects are conveyed to the brain.

The inside of the globe of the eye, within these tunics or coats, is filled with three humors called the aqueous, the crystalline, and the vitreous. The *aqueous* humor lies at the forepart of the eye, and occupies all the space between the crystalline and the prominent cornea. It has the same specific gravity and refractive power as water, and seems chiefly of use to prevent the crystalline from being easily bruised by rubbing, or by a blow—and perhaps it serves for the crystalline humor to move forward in while we view near objects; and backward, for remoter objects; without which, or some other mechanism effecting the same purpose, we could not, according to the law of optics, perceive objects distinctly when placed at different distances.—Behind the aqueous lies the *crystalline* humor, which is shaped like a double convex glass, and is a little more convex on the back than on the forepart. This humor is transparent like crystal, is nearly of the consistence of hard jelly, and converges the rays which pass through it from visible objects, to its focus at the bottom or back part of the eye.—The *vitreous* humor lies behind the crystalline, and fills up the greater part of the orb of the eye, giving it a globular shape. It is nearly of the consistence of the white of an egg, and very transparent; its forepart is concave, for the crystalline humor to lodge in, and its back part being convex, the retina is spread over it. It serves as a medium to keep the crystalline humor and the retina at a due distance. From what has been now stated, it is obvious, that the images of external objects are depicted on the retina, in an inverted position, in the same manner as the images formed by a common convex lens; but how the mind, in this case, perceives objects erect, is a question, about which the learned have been divided in their opinions.\*

The ball of the eye, as now described, is situated in a bony cavity, called its orbit, composed by the junction of seven different bones, hollowed out at their edges. This cavity is, in all the vacant spaces, filled with a loose fat, which serves as a proper medium for the eye to rest in, and as a socket in which it may move. It is sheltered by the eyebrows, which are provided with hair, to prevent the descending sweat of the forehead from running down into it. As a still further protection to this delicate organ, it is furnished with the eyelid, which, like a curtain, is drawn over it with inconceivable swiftness, for its security on the approach of danger. It also serves to

wipe from it superfluous moisture, and to cover it during sleep. In the upper part of its orbit it is furnished with a gland, to supply it with water sufficient to wash off dust, and to keep its outer surface moist, without which the cornea would be less transparent, and the rays of light would be disturbed in their passage; and the superfluous water is conveyed to the nose through a perforation in the bone.

For the purpose of enabling the eye to move in its socket, *six* muscles are provided. These are admirably contrived to move it in every direction, upward or downward, to the right or to the left, or in whatever direction the occasion may require; and thus we are spared the trouble of turning our heads continually toward the objects we wish to inspect. If we want to look upward, one of these muscles lifts up the orb of the eye; if we would cast our eyes to the ground, another muscle pulls them down. A third muscle moves the globe outward toward the temples, and a fourth draws it toward the nose. A fifth, which slides within a cartilaginous ring, like a cord over a pulley, and is fastened to the globe of the eye in two points, makes it roll about at pleasure. A sixth lies under the eye, and is designed to temper and restrain within proper bounds the action of the rest, to keep it steadily fixed on the object it beholds, and to prevent those frightful contortions which otherwise might take place.\* By these, and a multitude of other mechanical contrivances, all acting in harmonious combination, the eye, as a natural telescope and microscope, is made to advance, to recede, to move to the right, and to the left, and in every other direction; and to view near and distant objects with equal distinctness; so that a single eye, by the variety of positions it may assume, performs the office of a thousand.†

The utility of these several movements, and the pain and inconvenience which would be suffered were any of them wanting, can scarcely be conceived by any one whose eyes have always remained in a sound state. We are so much accustomed to the regular exercise of our visual organs, that we seldom reflect on the numerous delicate springs which must be set in action, before the functions of vision can with ease be performed. But were any one of the muscular organs, now described, to fail in its functions, we should soon experience so many inconveniences, as would throw a gloom on all the other comforts of life; and convince us how much we are indebted, every moment, to the provident care and goodness of our beneficent Creator, for thousands of enjoyments which we seldom think of, and for which we are never sufficiently grateful. “With much compassion, as well as astonishment, at the goodness of our loving Creator,” says Dr. Nicuwentyt, “have I considered the sad state of a certain gentleman, who, as to the rest, was in pretty good health, but only wanted the use of those two little muscles that serve to lift up the eyelid, and so had almost lost the use of his sight—being forced, as long as this defect lasted, to shove up his eyelids every moment with his own hands.”‡

How admirable, then, is the formation of the eye, and how grateful ought we to feel at the

\* An idea of the relative positions of the coats and humors described above, may be obtained by a simple inspection of the Frontispiece, Fig. 6.—Fig. 5 represents a front view of the human eye, as it appears in its natural state, and exhibits the relative positions of the Cornea, Iris, and Pupil.

† A more particular description of the muscles of the eye illustrated by two engravings, will be found in the author's volume, entitled, “The Improvement of Society by the Diffusion of Knowledge,” p. 72.

‡ These and other insects, whose eyes are immovable have several thousands of distinct globes in each eye. See Note, p. 34.

† Nicuwentyt's Religious Philosopher, vol. i, p. 232.



that every point of a visible object sends out rays of light in all directions; and therefore, a certain portion of the rays which flow from the object  $A B C$ , will fall upon the *cornea* between  $x$  and  $y$ ,

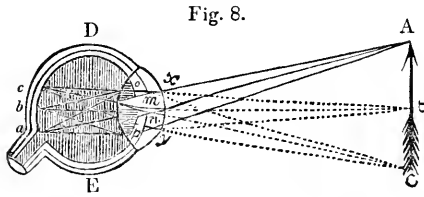

and passing through the *aqueous humor*,  $m n$ , and the *crystalline humor*,  $o p$ , and the *vitreous humor*,  $D E$ , will be converted to a focus on the retina, and paint a distinct picture,  $a b c$ , of the object  $A B C$ , in an inverted position. The rays from the point  $A$  of the object, after being refracted by the different humors, will be brought to a point at  $a$ ; those from  $B$  will be converged at  $b$ ; and those from  $C$  at  $c$ ; and of course the intermediate rays between  $A B$  and  $B C$  will be formed between  $a b$  and  $b c$ , and the object will become visible by means of its image or representation being painted on the retina, in all the colors and proportions which belong to it. If we take a bullock's eye, and cut off the three coats from the back part, and put a piece of thin white paper over that part, and hold the eye toward the window, or any bright object, we shall see the image of the object depicted upon the paper, and in an inverted position, as stated above.

In order that we may more distinctly perceive the wonders of vision, and the numerous circumstances on which it depends, let us suppose ourselves placed on an eminence, which commands a view of a variegated and extensive landscape.—Let us suppose ourselves stationed on Arthur's Seat, or on the top of Salisbury Crags, in the vicinity of Edinburgh. Turning our face to the north-west, the city, with its castles, spires, and stately edifices, presents itself to our view. Beyond it, on the north and west, a beautiful country, adorned with villas, plantations, and fertile fields, stretches as far as the eye can reach, until the view is bounded by the castle of Stirling, at a distance of more than thirty miles. On the right hand, we behold the port of Leith, the shipping in the roads, the coast of Fife, the isles of Inchkeith and of May, and the frith of Forth gradually losing itself in the German ocean. If we suppose the length of this landscape to be forty miles, and its breadth twenty-five, it will, of course, comprehend an area of a thousand square miles.

The first circumstance which strikes the mind, is the *immense multitude of rays of reflected light* which flow in all directions, from the myriads of objects which compose the surrounding scene.—In order to form a rude idea of this infinity of radiations I fix my attention on a single object. I direct my eye to Nelson's monument, on the Calton Hill. From the parapet at the top, a thousand different points send forth a thousand different cones of rays, which, entering my eye, render the different parts of it distinctly visible, beside myriads of rays from the same points, which flow in every other direction through the open spaces of the atmosphere which surround them. How many thousands of millions, then, of different radiations must be issuing forth every moment from the whole mass of the monument! And if one object pours forth such a flood of rays, how im-

mense must be the number of radiations which are issuing from all the objects which compose this extensive landscape! Myriads of rays, from myriads of objects, must be crossing each other in an infinity of directions, so that the mind is confounded at the apparent confusion which seems to exist in this immensity of radiations; yet every ray passes forward in the crowd, in the most perfect order, and, without being blended or confused with any other ray, produces its specific effect on every eye that is open to receive it. But this is not all: these millions of rays, which flow from the minutest points of the surrounding scene, before they can produce the sensation of vision, and form a picture of the landscape on the retina, must be compressed into a space little more than one-eighth of an inch in diameter, before they can enter the pupil of the eye; yet they all pass through this small aperture without the least confusion, and paint the images of their respective objects in exactly the same order in which these objects are arranged.—Another circumstance demands attention. The rays which proceed from the objects before me, are not all directed to the spot where I stand, but are diffused throughout every point of the surrounding space, ready to produce the same effect, wherever sentient beings are present to receive them. Were the whole inhabitants of Edinburgh placed on the sloping declivity of Arthur's Seat, and along the top of Salisbury Crags, and were millions of other spectators suspended in the surrounding atmosphere, similar sensations would be produced, and a scene similar to that which I now behold would be depicted in every eye. Amidst the infinity of cones of light, crossing each other in an infinity of directions, no confusion would ensue, but every spectator, whose eyes were in a sound state, would obtain a correct view of the scene before him; and hence it happens, that, whenever I shift my position to the right hand or to the left, other streams of light enter my eye, and produce the same effect.

Let me now attend to another circumstance, no less admirable than the preceding, and that is, the *distinct impression* which I have of the shape, color, and motion, of the multiplicity of objects I am now contemplating, and the *small space* within which their images are depicted at the bottom of my eye. Could a painter, after a long series of ingenious efforts, delineate the extensive landscape now before me on a piece of paper not exceeding the size of a silver sixpence, so that every object might be as distinctly seen, in its proper shape and color, as it now appears when I survey the scene around me, he would be incomparably superior to all the masters of his art that ever went before him. This effect, which far transcends the utmost efforts of human genius, is accomplished in a moment, in millions of instances, by the hand of Nature, or, in other words, by "the finger of God." All the objects I am now surveying, comprehending an extent of a thousand square miles, are accurately delineated in the bottom of my eye, on a space *less than half an inch* in diameter. How delicate, then, must be the strokes of that divine pencil which has formed such a picture! I turn my eyes to the castle of Edinburgh, which appears one of the most conspicuous objects in my field of view.—Supposing that portion of it which strikes my eye to be 500 feet long, and 90 in height, I find, by calculation, that it occupies only the six-hundred-thousandth part of the whole *visual field*; and, consequently, fills in my eye no more than the twelve-hundred-thousandth part of an inch. I

next direct my eye toward the Frith of Forth, and perceive a steamboat sailing between Queensferry and Newhaven. I distinctly trace its motion for the space of 40 minutes, at the end of which it reaches the chainpier at Newhaven, having passed over a space of five miles in length, which is but the eighth part of the *lineal* extent of the landscape in that direction; and, consequently, occupies, in the picture formed on my retina, a lineal space of only one-sixteenth of an inch in extent. And, if the boat be reckoned about 88 feet in length, its image is only the three-hundredth part of this extent; and, of course fills a space in the eye of only the four-thousand-eight-hundredth part of a *lineal* inch. Yet, my perception of the motion of the vessel could be produced by only a corresponding motion of its image in my eye; that is, by the *gradual* motion of a point one-four-thousand-eight-hundredth part of an inch in diameter, over a space one-sixteenth of an inch in length. How inconceivably fine and accurate, then, must be the impression of those strokes which the rays of light, from visible objects, produce on the retina of the eye! The mind is lost in wonder when it attempts to trace so exquisite and admirable an effect.

I take a reflecting telescope, and through it view some of the distant parts of the landscape. My wonder is still increased when I consider the new directions into which the rays of light are bent—the crossings and recrossings, the refractions and reflections, that take place between the mirrors and the lenses of the instrument, and the successive images that are formed—so that, instead of a scene of confusion, which previous to experience, might have been expected from the numerous additional bendings and intersections of the rays—I now perceive hundreds of objects, with the most perfect distinctness, which were before invisible. Rays of light from distant and minute objects, which a moment before made no sensible impression on my eye, being collected and variously modified by the telescope, now paint a vivid representation of their objects in their true figures, colors, and positions.

From a consideration of the innumerable modifications of the rays of light, and of the immense variety of effects they produce in every region of the earth—I am led to investigate *what proportion of the solar light falls upon our globe*, in order to produce so diversified a scene of sublimity and beauty. Supposing the sun's rays to be chiefly confined, in their effects, within the limits of the planetary system, since they diverge in every direction, they must fill a cubical space 3,600,000,000 miles in diameter; which consequently will contain about 24,000,000,000,000,000,000,000,000 of cubical miles, so that an eye, placed in any point of this vast space, would receive a distinct impression from the solar rays. The solidity of the earth is about 264,000,000,000 cubical miles, and, therefore it receives only the  $\frac{1}{90,000,000,000}$  part of the light which fills the sphere of the solar system. So that the light which cheers all the inhabitants of the world, and unavails such a variety of beautiful and magnificent objects, is nothing more than a *single stream* of celestial radiance out of ninety thousand billions of similar streams, which the great source of light is every moment diffusing throughout surrounding worlds. But the solar rays are not confined within the bounds of the planetary system; their influence extends, in every direction, as far as the nearest stars, filling a cubical space at least 40,000,000,000,000 miles in diameter, and which contains 33,500,000,

000,000,000,000,000,000,000,000,000,000, or, thirty-three thousand five hundred sextillions of cubical miles. And were we to institute comparisons and calculations with respect to the possible variety of effects they might produce throughout this immense region, whole pages might be filled with figures, ciphers, and computations. We might compute how many globes similar to the earth, or any of the larger planets, might be contained within this vast space, allowing several hundreds of cubical miles of empty space around each globe—how many myriads of refractions and reflections the rays of light would suffer, in regard to the peculiar objects connected with every one of these globes—how many eyes of sentient beings might be affected, by the diversities of color, shape, and motion which would thus be produced—and what a variety of shades of light and color, and what a diversity of scenery would be produced, according to the distances of the respective globes from the central luminary. After what we have just now stated, however, we may rest satisfied with joining in the pious exclamation of one who had just finished a devout survey of the structure of the human frame: "Marvelous are thy works, and that my soul knoweth right well. How precious are thy thoughts unto me, O God!" (or, as the words might be rendered), "How precious are thy wonderful contrivances concerning me, O God! how great is the sum of them? If I should count them they are more in number than the sand." In what direction soever I turn mine eyes, whatever portion of thy works I investigate, "I am still with thee."\* Thine infinity and unsearchable wisdom are impressed on every object, so that I feel myself every moment encompassed by thine immensity, and am irresistibly led to wonder and adore.

I shall now conclude these reflections on vision, with two or three additional remarks. It is worthy of notice, in the first place, that the eye has the power of adapting itself to objects placed at different distances. By means of some delicate pieces of mechanism, not hitherto satisfactorily explained, it can perceive, with distinctness, a large object at the distance of six miles, and the next moment it can adjust itself to the distinct perception of an object at the distance of six inches; so that it acts the part both of a telescope and a microscope, and can be *instantaneously* adjusted to perform either as the one instrument or as the other. This necessarily supposes a corresponding alteration in the state of the organ, every time we lift our eye from a *near* to look at a *distant* object. Either the *cornea* is somewhat flattened, or the crystalline humor is pushed backward, or both these changes, in combination with others, may concur in causing the rays from distant objects to unite exactly on the retina, without which, distant vision cannot be produced.—This contrivance, in whatever kind of mechanism it may consist, is one which art would vainly attempt to imitate. We can see objects that are near us with a microscope; and those that are distant with a telescope; but we should in vain attempt to see distant objects with the former, or those that are only a few inches from us with the latter, without a variety of changes being made in the apertures and positions of the glasses belonging to the respective instruments. In this respect therefore, as well as in every other, the eye is an optical instrument, incomparably superior to any instrument or imitation that art can produce; and were it not for the peculiar property

\* Psalm cxxxix. 14, 17, 18

now described, it would be almost unfit for the purpose of vision, notwithstanding all the other delicate contrivances which enter into its construction. If it were adjusted only for the distinct perception of distant objects, every object within the limits of an ordinary apartment would appear a mass of confusion; and were it adjusted solely for viewing objects within the limits of a few feet or inches, the glories of the heavens, and the beautiful landscape of the earth, would be veiled from our sight, as if they were enveloped in a mist.

Another circumstance worthy of attention, is the power which the *pupil* of the eye possesses of contracting or enlarging the aperture or hole through which the light is admitted. When the light is too weak, the pupil is enlarged; when it is too strong, it is again contracted. Accordingly we find, that when we enter a darksome apartment, though, at first, nothing can be accurately distinguished, yet, in the course of a minute or two, when the pupil has had time to dilate, we can perceive most objects with considerable distinctness. And, on the other hand, when we pass from a dark room to an apartment lighted up with a number of lustres, we feel uneasy at the sudden glare, until the pupil has contracted itself, and excluded a portion of the superfluous rays. Were it not for this property, we should, for the most part, either be surrounded with a disagreeable gloom, or oppressed with an excessive splendor.—It is for this reason that we are unable to look upon the sun without being dazzled, and are under the necessity of closing the eyelids, or of turning away the head, when a strong light suddenly succeeds to darkness.

Again, it may not be improper to observe, how wisely the Author of Nature has fixed the distance at which we ordinarily see near objects most distinctly. This distance is generally from five to eight inches from the eye. But, had the eye been formed for distinct vision, at the distance of only one inch, the object would have obstructed the light, and room would have been wanting for the performance of many necessary operations, which require the hand to intervene between the eye and the object. And had the limits of distinct vision for near objects been beyond two or three feet, sufficient light would not have been afforded for the inspection of minute objects, and we could neither have written a letter nor have read a book with the same convenience and ease we are now enabled to do.

From the preceding descriptions and remarks, it will evidently appear, with what admirable skill the different parts of the organs of vision are constructed, and how nicely they are adapted to the several ends they were intended to subservise.—Were any one of these parts deficient, or obstructed in its functions, vision would either be impeded, or rendered painful and distressing, or completely destroyed. If any of the *humors* of the eye were wanting—if they were less transparent—if they were of a different refractive power—or if they were of a greater or less convexity than they now are, however minute the alteration might be, vision would inevitably be obstructed, and every object would appear confused and indistinct. If the retina, on which the images of objects are painted, were flat, instead of being concave, while objects in the middle of the view appeared distinct, every object toward the sides would appear dim and confused. If the *cornea* were as opaque as the scleroticæ, to which it is joined, or if the retina were not connected with the optic nerve, no visible object could possibly be

perceived. If one of the six muscles of the eye were wanting, or impeded in its functions, we could not turn it to the right; if a second were deficient, we could not turn it to the left; if a third, we could not lift it upward; if a fourth, we could not move it downward; and if it were deprived of the other two muscles, it would be apt to roll about in frightful contortions. If the eyes were placed in any other part of the body than the head—if they were much more prominent than they now are—if they were not surrounded by the bony socket in which they are lodged—and if they were not frequently covered by the eyelid—they would be exposed to a thousand accidents from which they are now protected. If they wanted moisture, and if they were not frequently wiped by the eyelids, they would become less transparent, and more liable to be inflamed; and if they were not sheltered by the eyebrows, the sweat and moisture of the forehead would frequently annoy them. Were the *light* which acts upon them devoid of color—were it not reflected from objects in every direction—were its motion less swift, or its particles much larger than they now are—in short, were any one circumstance connected with the structure of this organ, and with the modification of the rays of light, materially different from its present arrangement, we should either be subjected to the hourly recurrence of a thousand painful sensations, or be altogether deprived of the entertainments of vision.

How admirable an organ, then, is the eye, and how nicely adapted to unveil to our view the glories of the universe! Without the application of any skill or laborious efforts on our part, it turns in every direction, transports us to every surrounding object, depicts the nicest shades and colors on its delicate membranes, and

“Takes in, at once, the landscape of the world  
At a small inlet, which a grain might close,  
And half creates the wondrous world we see.”—YOUNG.

—How strikingly does it display, in every part of its structure and adaptations, the marks of benevolent design, and of Infinite Intelligence!—However common it is to open our eyes, and to behold, in an instant, the beauties of an extensive landscape, and however little we may be accustomed to admire this wonderful effect—there is not a doctrine in religion, nor a fact recorded in Revelation, more mysterious and incomprehensible. An excellent French writer has well observed—“The sight of a tree and of the sun, which God shows me, is as real and as immediate a Revelation as that which led Moses toward the burning bush. The only difference between both these actions of God on Moses and me is, that the first is out of the common order and economy; whereas the other is occasioned by the sequel and connection of those laws which God has established for the regulation both of man and nature.”

If then, the eye of man (who is a depraved inhabitant of a world lying partly in ruins), is an organ so admirably fitted for extending our prospects of the visible creation—we may reasonably conclude, that organized beings of superior intelligence and moral purity, possess the sense of vision in a much greater degree of perfection than man in his present state of degradation—and that they may be enabled, by their *natural* organs, to penetrate into regions of the universe far beyond what man, by the aid of artificial helps, will ever be able to descry. It may not be altogether extravagant, nor even beyond the reality of existing facts, to suppose, that there are intelligences

In the regions of Jupiter or Saturn, whose visual organs are in so perfect a state, that they can descry the mountains of our moon, and the continents, islands, and oceans which diversify our globe, and are able to delineate a map of its surface, to mark the period of its diurnal rotation, and even to distinguish its cities, rivers, and volcanoes. It is quite evident, that it must be equally easy to Divine Wisdom and Omnipotence, to form organs with powers of vision far surpassing what I have now supposed, as to form an organ in which the magnificent scene of heaven and earth is depicted, in a moment, within the compass of half an inch. There are animals whose range of vision is circumscribed within the limits of a few feet or inches; and, had we never perceived objects through an organ in the same state of perfection as that with which we are furnished, we could have formed as little conception of the sublimity and extent of our present range of sight, as we can now do of those powers of vision which would enable us to descry the inhabitants of distant worlds. The invention of the telescope shows, that the penetrating power of the eye may be indefinitely increased; and, since the art of man can extend the limits of natural vision, it is easy to conceive, that, in the hand of Omnipotence, a slight modification of the human eye might enable it, with the utmost distinctness, to penetrate into regions to which the imagination can set no bounds. And therefore it is not unreasonable to believe, that, in the future world, this will be one property, among others, of the *resurrection-body*, that it will be furnished with organs of vision far superior to the present, in order to qualify its intelligent inhabitant for taking an ample survey of the "riches and glory" of the empire of God.

I have dwelt somewhat particularly on the functions of the eye, in order to show, that it is only when we take a *minute* inspection of the operations of the Creator, that his Infinite Wisdom and Intelligence are most distinctly perceived. The greater part of Christians will readily admit, that the Wisdom of God is manifested in every object; but few of them take the trouble to inquire, in *what particular contrivances and adaptations* this wisdom is displayed; and, therefore, rest satisfied with vague and general views, which seldom produce any deep impression on the mind. "The works of the Lord," which are "great" and admirable, "*must be sought out by all those who have pleasure therein;*" and the more minutely they are inspected, the more exquisite and admirable do all his arrangements appear.

Were we to enter into an investigation of the *visual organs of the lower animals*, and to consider the numerous varieties which occur in their structure, position, and movements, and how nicely the peculiar organization of the eye is adapted to the general structure of the animal, and to its various necessities and modes of existence—the operation of the same inscrutable Wisdom and Intelligence would meet our eye at every step. *Birds*, for example, which procure their food by their beak, have the power of seeing distinctly at a very small distance; and, as their rapid motions through the air renders it necessary that they should descry objects at a considerable distance, they have two *peculiar mechanical contrivances*, connected with their organs of vision, for producing both these effects. One of these contrivances consists in a flexible rim, formed of bone, which surrounds the broadest part of the eye; and, by occasionally pressing upon its orb, shortens its focal distance,

and thus enables it to inspect very near objects. The other consists of a peculiar muscle, which draws back, as occasion requires, the crystalline humor, by which means it can take a distinct view of a distant landscape, and can pass from the sight of a very near to the sight of a distant object, with rapidity and ease. In *fishes*, which live in a medium of a different refractive power from that of air, the crystalline humor has a greater degree of convexity, and more nearly approaches to a globular form than that of land animals—which conformation is essentially requisite to distinctness of vision in the watery element. A fish, of course, cannot see distinctly in air, nor a quadruped under water; and every person who has dived into the water with his eyes open, knows that though he may perceive the general forms and colors of objects, his vision is obscure and indistinct.—In *hares* and *rabbits*, the eyes are very convex and prominent, so that they can see nearly quite round them; whereas, in *dogs*, which pursue these animals, the visual organs are placed more in the front of the head, to look rather before than behind them.—Some animals, as *cats* and *owls*, which pursue their prey in the dark, have the pupil of their eye so formed as to be capable of great expansion, so that a few rays of light may make a lively impression on their retina; while the *eagle*, which is able to look directly at the sun, has its pupil capable of being contracted almost to a point.—Insects, such as the *bee*, the *fly*, and the *butterfly*, whose eyes are incapable of motion, have several thousands of small transparent globes, set in a convex hemisphere, every one of which is capable of forming an image of an object; so that they are enabled to view the objects around them without moving their heads.—But it would be beyond the limits of my plan to prosecute this subject any further: enough has already been stated, to show that the eyes of men and of other animals are masterpieces of art, which far transcend the human understanding; and that they demonstrate the consummate wisdom of Him who planned and constructed the organical functions of the various tribes of animated existence.

I shall conclude this branch of my subject, by presenting an instance or two of the *mechanism of the bones*, and the movements it is fitted to produce.

The bones of the human frame are *articulated*, or connected together in different ways, but most frequently in the following manner:—Either, first, a bone with a round head is articulated with a cavity, and plays with it as a ball in the socket; or, second, they are connected together by a hinge-like articulation, which enables a bone to move up or down, backward or forward, like a door upon its hinges. An idea of these two motions, and the purposes they serve, may be obtained, by considering the construction of the pedestal of a telescope, and the joints on which it moves. One of the joints is of the nature of a hinge, by which a vertical motion, or a motion upward and downward, is produced. A horizontal motion, or a motion toward the right hand or the left, is produced by a pivot moving in a socket; so that, by these two motions, the telescope can be made to point in any direction. Such is the nature of the articulations in the bones, and the movements they produce; and whenever one or other of these motions, or both of them combined, is requisite for the comfort and convenience of the individual, such a power of motion is uniformly found to exist. If the movement of a joint in every direction would in any particular case be found incon-

venient, the hinge-like articulation is fixed upon: but if a motion in every direction is required for the convenient use of particular members, and for the variety of evolutions which a sentient being may have occasion to make, the ball and socket articulation is combined with the former.

For example, let any person for a moment consider the joints of his fingers, and compare them with the joint at his *wrist*, where the hand is connected with the fore-arm. If he hold the back of his hand upward, he will find that he can move his fingers upward or downward; but he cannot turn them to the right hand or to the left, so as to make them describe a circular motion. He will also find that his *wrist* is capable of a similar movement, so that the hand may be bent in a vertical direction. But, in addition to this motion, it is also capable of being turned in a horizontal direction, or from one side to another. In the former case, we have an example of the hinge articulation; in the latter, it is combined with an articulation which produces nearly the same effect as a pivot moving in a socket. Now, had the joints of the fingers been capable of the same motions as the wrist, the hand would have lost its firmness, and been incapable of performing a variety of mechanical operations which require objects to be held with a steady grasp. On the other hand, if the wrist had been confined to a vertical motion, the hand would have been incapable of one out of a hundred varied movements which it can now perform with the greatest ease.\* In

this case, we could not have bored a hole with a gimlet, cut down corn with a sickle, digged the earth with a spade, sewed clothes with a needle, tossed up a ball, or turned up the palm of the hand, for any of the useful purposes for which that motion was ordained. In short, without the rotatory motion of the wrist, the greater part of the operations connected with gardening, agriculture, cookery, washing, spinning, weaving, painting, carving, engraving, building, and other mechanical arts, could not be performed; and such of them as could be effected, would be accomplished only with the greatest inconvenience and labor. Any person may convince himself of this, by holding his hand in a horizontal position, and preventing his wrist joint from turning round, and then by trying what operations he can easily perform without the rotatory motion; and he will soon perceive with what exquisite skill the numerous movements of our animal frames have been contrived by the Great Author of our existence. In each hand there are 27 bones, all of which are essential to the different motions we wish to perform. Every finger is composed of three bones, connected together by articulations, muscles, and ligaments. If, instead of three, each

every minute part and motion connected with our animal frame to subserve our convenience and pleasure. No one who is acquainted with the minute and exquisite mechanism of the human body, will dare to call in question, the skill, the design, and the forethought of the Great Artificer of that wonderful frame; and he must possess a cold and unfeeling heart, who can behold with apathy, and without reverence and gratitude, the multitudinous mass of splendid and exquisite contrivances of which he every moment feels the pleasure and advantage.

\*The horizontal motion of the wrist, or that motion by which the palm of the hand is alternately turned up and down, is produced chiefly by the motions of the two bones of the fore-arm, called the *radius* and the *ulna*, one of which is articulated to the *humerus*, or bone connected with the shoulder.—In the following representation (fig. 9), C is the *humerus* or shoulder bone; B is the elbow where the two bones of the fore-arm are connected with the humerus; D is the *radius*, which joins the wrist, on the side where the thumb is, and E the *ulna*, which joins the wrist on the side where the little finger is. In fig. 10, G is the *radius*; fig. 11, H is the *ulna*. The *ulna* has a hooked process marked c, which catches round the lower end of the humerus, forming with it a hinge joint. This bone projects beyond the head of the humerus, forming, when the arm is bent, the point of the elbow. The *radius* has a small round head B, on which it turns, without any motion of the humerus—bound to the ulna by ligaments—and as the bones of the wrist are attached to the lower end of this bone alone, and not to the ulna, —when the radius revolves the whole hand turns with it. This alternate rolling is what anatomists call *pronation* and *supination*. Flexion and extension of the arm are performed by means of the ulna, which carries the radius along with it in all its movements. While the larger part of the ulna is above, the larger part of the radius is below, so that while the former presents a large surface for articulation at the elbow, the latter does the same at the wrist, and this inverse arrangement, likewise, contributes to the uniform diameter of the fore-arm. While the fore-arm is thus attached to the humerus, the radius is attached to the wrist, so that when we turn the palm of the hand the radius rolls on the ulna by the help of a groove or hollow near each end of the bone, carrying the hand with it. So admirable, indeed, is this contrivance, that both motions may be performed at the same time; for while we are bending the arm, we may also be rotating or turning it upon its axis. To facilitate these motions, a tubercle of the radius plays into a socket of the ulna, near the elbow,—while near the wrist, the radius finds the socket, and the ulna the tubercle.

Now, had both bones been joined to the upper arm at the elbow, or both to the hand at the wrist, the motions now stated could not have been accomplished. The first bone was to be at liberty at one end, and the second at the other, by which means the two motions may be performed together. The bone which carries the fore-arm may be swinging upon its hinge at the elbow, at the very time that the other bone which carries the hand may be turning round it in its groove. Had there been only a single bone in the fore-arm, with a ball and socket at the elbow, it might, in a certain degree, have accomplished the purpose intended; but in this case, the turning of the hand and arm would have been effected by a comparatively slow and laborious motion. Such is the wonderful care and accuracy with which our All-Wise and Benevolent Creator has contrived and adjusted

Fig. 9.

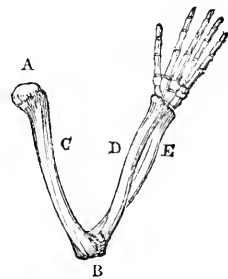

Fig. 10.

Fig. 11.



In the human hand, in particular, we perceive an instrument far superior to that of any similar part connected with the structure of the lower animals. In this hand we perceive the sensibilities to changes of temperature, to touch, and to motion, combined with a facility in the joints of unfolding and moving in every possible degree and direction, and in a manner inimitable by any artifice of joints and levers. In all the movements of human beings, it is the hand that guides them in their industry and mental acquisitions. By its assistance they have drained unwholesome marshes—transformed deserts into fruitful fields—turned the course of rivers—barked out the headlong sea—cleared the thickest forests, and caused cities, temples, and palaces to arise where the wild beasts of the forests formerly roamed at large. In short, by this instrument Man has been enabled to prosecute his course along pathless oceans and through the region of the clouds—to measure time and space—to investigate the wonders of the earth and of the heavens, and to promote his progress toward intellectual perfection,—and, without it, scarcely any science or department of human knowledge could be acquired or cultivated—supposing the whole human race to have been destitute of this instrument.



finger were composed of only one bone, it would be quite impossible for us to grasp a single object.

The same admirable contrivance may be perceived in the movements of which the *head* is susceptible. It was requisite, in order to our convenience and comfort, that we should be enabled to move our head backward or forward—to look up toward the heavens, or downward to the ground. It was also expedient that it should have a power of turning to the right or to the left, so as to take in a considerable portion of a circle, without being under the necessity of turning round the whole body. Accordingly we find that both these motions are provided for, in the manner in which the head is connected with the *vertebræ*. The head rests upon the uppermost of these bones, to which it is connected by a hinge joint, similar to those in the fingers, which allows it to move backward and forward; and by means of a round, longish process, or projection, which moves in a socket, it is enabled to move horizontally, as upon an axis. Had the first motion been wanting, we could not have looked up to the zenith, without lying flat on our back; nor could we have looked to the ground, without placing our bodies in a prone position; and, in such a case, we could never have seen our own feet, unless when they were bent considerably forward. Had the second motion been wanting, we could have looked to nothing, except the objects directly before us, without the trouble of turning round the whole body, either to the right or to the left. But, in the construction of our corporeal system, everything is so arranged and adapted to another, as at once to contribute to ease and facility of motion, in all the varied operations and movements we have occasion to perform; which circumstance forcibly demonstrates both the benevolent intentions and the admirable wisdom of Him “whose hands have made and fashioned us,” and who “breathed into our nostrils the breath of life.”

The above are only two or three out of a hundred of similar instances, which might be produced to show the benevolent care which has been exercised in arranging and articulating the system of bones of which the propwork of the human frame is composed. Were we to enter into an investigation of the actions and uses of the various muscles, the wonderful system of veins and arteries, the action of the heart, stomach, and bowels; the process of respiration, and insensible perspiration, and the system of nerves, glands, lymphatics, and lacteals—a thousand instances of Divine wisdom and beneficence would crowd upon our view, which could not fail to excite the pious and contemplative mind to join in the devotions of the “sweet singer of Israel:”—“I will praise thee; for I am fearful and wonderfully made: marvellous are thy works, and that my soul knoweth right well.”—But as I intended to present only a few specimens of the Wisdom of God, as displayed in the construction of the material world, I shall conclude this department of my subject with a single reflection.\*

*How foolish and ungrateful is it for rational beings to overlook the wise and benevolent arrange-*

*ments of the Creator, in the material universes.* How many thousands of human beings pass their existence without once reflecting on the numerous evidences of Divine Wisdom and Beneficence which appear around them, or feeling the least spark of gratitude for their preservation and comforts, to that Being “in whose hand their breath is, and whose are all their ways!” Yea, how many are there who consider themselves as standing high in the ranks of the Christian profession, who affect to look down with a certain degree of contempt on the study of the material works of God, as if it were too gross a subject for their spiritual attainments! They profess to trace the wisdom of God in the Scriptures, and to feel gratitude for his pardoning mercy; but they seldom feel that gratitude which they ought to do for those admirable arrangements in their own bodies, and in the elements around them, by which their lives are preserved, and their happiness promoted; and even seem to insinuate that they have little or nothing to do with the contrivances of the God of Nature. They leave it to the genius of infidel philosophers to trace the articulation of the bones, the branchings of the veins and arteries, the properties of light, and the composition of the atmosphere, while they profess to feast their minds on more sublime and spiritual entertainments. But surely such astonishing displays of the wisdom and benignity of the Most High, as creation exhibits, were never intended to be treated by his intelligent offspring with apathy or indifference; and to do so must indicate a certain degree of base ingratitude toward Him whose incessant energy sustains the whole assemblage of sentient and intelligent beings, and who displays himself, in their construction and preservation, to be “wonderful in counsel and excellent in working.” Shall we imagine, that because God stands in the gracious relation of our Redeemer, he has ceased to stand in the relation of our Creator and Preserver? Or shall we consider those subjects as unworthy of our attention, which are the theme of the praises of the heavenly host? Can we suppose that the Almighty displayed his infinite wisdom in the curious organization of the human eye, that man—the only being in this world who is endowed with faculties capable of appreciating its structure, and for whose use and entertainment it was intended—should overlook such a wonderful piece of Divine workmanship, and feel no gratitude for the bestowment of so admirable a gift? Shall we extol the ingenuity displayed in a clock or a watch, in a chess-player, or a steam-engine, and shall we feel no sentiment of admiration at the view of millions of instances of Divine mechanism, which infinitely transcend the powers of the human understanding? To act in this manner, as too many are disposed to do, is unworthy of man, both as a Christian and as an intelligent agent. Such was not the conduct of the inspired writers: their spirituality of views did not lead them to neglect the contemplation of any of the works of God. “I will meditate on all thy works,” says the Psalmist, “and talk of all thy doings; I will utter abundantly the memory of thy great goodness, and speak of all thy wondrous works.” Accordingly we find, that the wonders of the human frame, the economy of the animal and the vegetable tribes, the scenery of the “dry land,” and of the “mighty deep,” and the glories of the heavens, were the frequent subjects of their devout contemplation. They con-

\* Those who wish to prosecute this subject, particularly that part of it which relates to the contrivances of Divine Wisdom which appear in the animal system, will find ample gratification in Newton’s “Religious Philosopher,” Vol. I. Bell’s Bridge-water Treatise of “The Hand,” and Dr. Paley’s “Natural Theology.” A variety of useful remarks on this subject will also be found in “Ray’s Wisdom of God in the Creation,” Derham’s “Physico-Theology,” and Bonnet’s “Contemplation of Nature.”

\* Revelation iv. 11.

sidered them in relation to the unceasing agency of God, by whom they were formed and arranged, and as declaring his Wisdom, Goodness, and Omnipotence; and with this view ought all the scenes of the visible creation to be investigated by his intelligent creatures.

We have reason to believe that it is owing, in part, to want of attention to the Divine wisdom and beneficence, as exhibited in the construction of the visible world, that many professed Christians entertain so vague and confused ideas respecting the wisdom and goodness of Deity, as displayed in the economy of Redemption. The terms, Wisdom, Goodness, and Beneficence, in their mouths, become words almost without meaning, to which no precise or definite ideas are attached; because they have never considered the instances and the evidences of these attributes, as displayed in the material creation. And if our minds have not been impressed with a sense of the wisdom and beneficence of God, in those objects which are presented to the external senses, we cannot be supposed to have luminous and distinct ideas of those spiritual objects and arrangements which are removed beyond the sphere of our corporeal organs. For all our ideas in relation to Religion and its objects, are primarily derived from the intimations we receive of external objects, through the medium of our senses; and, consequently, the more clearly we perceive the agency of God in his visible operations, the more shall we be qualified to perceive the wisdom and harmony of his dispensations, as recorded in the volume of inspiration.

We live in a world, all the arrangements of which are the effects of infinite wisdom. We are surrounded with wonders on every hand; and therefore we cease to admire, or to fix our attention on any one of the wonders daily performed by God. We have never been accustomed to contemplate, or to inhabit a world where benevolence and wisdom are not displayed; and therefore we are apt to imagine that the circumstances of our terrestrial existence could not have been much otherwise than they actually are. We behold the sun in the morning ascending from the east—a thousand shining globes are seen in the canopy of the sky when he has disappeared in the west. We open our eyelids, and the myriads of objects which compose an extensive landscape are in a moment painted on our retina,—we wish to move our bodies, and in an instant the joints and muscles of our hands and feet perform their several functions. We spread out our wet clothes to dry, and in a few hours the moisture is evaporated. We behold the fields drenched with rain, and in a few days it disappears and is dispersed through the surrounding atmosphere, to be again embodied into clouds. These are all *common* operations, and therefore thoughtless and ungrateful man seldom considers the obligations he is under to the Author of his existence, for the numerous enjoyments which flow from these wise arrangements. But were the globe we inhabit, and all its appendages, to remain in their present state—and were only the principle of *evaporation* and the *refractive* and *reflective properties of the air* to be destroyed—we should soon feel, by the universal gloom which would ensue, and by a thousand other inconveniences we should suffer, what a miserable world was allotted for our abode. We should most sensibly perceive the wisdom and goodness we had formerly overlooked, and would most ardently implore the restoration of those arrangements for which we were never sufficiently grateful. And why should we not *now*—while we en-

joy so many comforts flowing from the plans of Infinite Wisdom—have our attention directed to the benevolent contrivances within us and around us, in order that grateful emotions may be hourly arising in our hearts to the Father of our spirits? For the essence of true religion consists chiefly in *gratitude* to the God of our life, and the Author of our salvation; and every pleasing sensation we feel from the harmonies and the beauties of nature, ought to inspire us with this sacred emotion.—“Hearken unto this, O man! stand still and consider the wonderful works of God. Contemplate the balancings of the clouds, the wondrous works of Him who is perfect in knowledge.” “He hath made the earth by his power, he hath established the world by his wisdom. When he uttereth his voice, there is a noise of waters in the heavens; he causeth the vapors to ascend from the ends of the earth, and bringeth the winds out of his treasures.” While it is shameful for man to be inattentive to the wonders which surround him, what can be more pleasing and congenial to a rational and devout mind than contemplations on the works of the Most High? “What can be more gratifying,” says Sturm, “than to contemplate in the heavens, in the earth, in the water, in the night and day, and, indeed, throughout all nature, the proofs which they afford of the wisdom and purity, and the goodness of our great Creator and Preserver! What can be more delightful than to recognize, in the whole creation, in all the natural world, in everything we see, traces of the ever-working providence and tender mercy of the great Father of all.”

#### SECTION IV.

##### ON THE GOODNESS OR BENEVOLENCE OF THE DEITY

THE benevolence of God is that perfection of his nature, by which he communicates happiness to the various ranks of sensitive and intelligent existence.

The system of Nature, in all its parts, exhibits an unbounded display of this attribute of the Divine Mind, both in relation to man, and in relation to the subordinate tribes of animated existence. In relation to *Man*—the magnificence and glory of the heavens—the variegated coloring which is spread over the scene of nature—the beautiful flowers, shrubs, and trees, with which the earth is adorned, which not only delight the eye, but perfume the air with their delicious odors—the various kinds of agreeable sounds that charm the ear—the music of the feathered songsters, which fill the groves with their melody—the thousands of pleasant images which delight the eye, in the natural embellishments of creation—the agreeable feelings produced by the contact of almost everything we have occasion to touch—the pleasure attached to eating, drinking, muscular motion, and activity—the luxuriant profusion and rich variety of aliments which the earth affords—and the interchanges of thought and affection—all proclaim the Benevolence of our Almighty Maker, and show, that the communication of happiness is one grand object of all his arrangements. For these circumstances are not *essentially* requisite to our existence. We might have lived and breathed, and walked, though everything we touched had produced pain; though everything we ate and drank had been bitter; though every movement of our hands and feet had been accompanied with uneasiness

and fatigue; though every sound had been as harsh as the saw of the carpenter; though no birds had warbled in the groves; though no flowers had decked the fields, or filled the air with their perfumes; though one unvaried scene of dull uniformity had prevailed, and beauty and sublimity had been swept from the face of nature; though the earth had been covered with a mantle of black, and no radiant orbs had appeared in our nocturnal sky. But what a miserable world should we then have inhabited, compared with that which we now possess! Life would have passed away without enjoyment, and pain would have overbalanced the pleasures of existence. Whereas, in the existing constitution of things, all the objects around us, and every sense of which we are possessed, when preserved in its natural vigor, have a direct tendency to produce pleasing sensations, and to contribute to our enjoyment; and it is chiefly when we indulge in foolish and depraved passions, and commit immoral actions, that the benevolent intentions of the Deity are frustrated, and pain and misery produced.

Had the Creator of the world been a malevolent being, and possessed of infinite power and intelligence, every arrangement of nature would have been almost the reverse of what we now find it. The production of *evil*, and of pain in sensitive beings, would have been the *aim* of the contriver in all his operations and allotments. All design in the frame of the universe, and all that wisdom and intelligence which we now admire in the adaptations of the parts and functions of animals to their necessities and to the constitution of nature around them—we should have dreaded as contrivances to produce painful sensations, and to render them acute and permanent. Instead of ease, and enjoyment, and delight, in the exercise of our functions and faculties—the ordinary state of the lower animals and of human beings would have been a state of trouble, disease, dejection, and anguish. Every breath of air might have cut us like the point of a dagger, or produced a pain like that of swallowing aquafortis or sulphuric acid.\* Every touch might have been felt like the sting of a nettle, or like the rubbing of salt upon a festering wound. Every taste would have been bitter as gall and wormwood, and every sound harsh and discordant, or as a hideous scream. All our senses, instead of being the sources of pleasure, as they now are, would have been the instruments of pain and torture. The lower animals, instead of ministering to our delight and necessities, would have been formed so as to torment, to harass, and annoy us. The cow and the goat would have afforded us no milk, nor the bee its honey, nor would the birds of the air have charmed us with their music. Dismal and haggard objects would have been strewed over the whole face of creation, and all would have appeared a melancholy gloom, without beauty or variety. The fields would have wanted their delightful verdure, their diversified aspect, and the beautiful flowers with which they are now adorned. The fire might have searched without warming us, and water, instead of refreshing us, might have produced intolerable pain. The light might have been without color; it might have dazzled instead of cheering us, and prevented distant objects from being perceived. Our eye-balls might have wanted the

muscles which now enable them to move with ease in every direction, and every ray of light might have affected them with pain. The ground might have been formed so soft and yielding, that at every step we should have sunk like persons walking in a quagmire.—In short, our imaginations, in such a case, would have presented to us little else than frightful specters and objects of terror and alarm,—and our minds have been filled with dismal forebodings and dreadful expectations. But, every arrangement in the system of nature, as it is now constituted, is directly the reverse of what we have now supposed. And this consideration demonstrates, that the Great Creator of the universe is the God of Love, whose mercy and benevolence are displayed toward every rank of sensitive and intelligent existence, and these attributes, we are assured, will never cease in their operations, so long as the universe endures.

If we consider, further, that the inexhaustible bounty of the Creator, and the numerous pleasures we enjoy, are bestowed upon a guilty race of men, the Benevolence of the Deity will appear in a still more striking point of view. Man has dared to rebel against his maker; he is a depraved and ungrateful creature. The great majority of our race have banished God from their thoughts, trampled upon his laws, neglected to contemplate his works, refused to pay him that tribute of reverence and adoration which his perfections demand, have been ungrateful for his favors, have blasphemed his Name, and have transferred to "four-footed beasts and creeping things," that homage which is due to him alone. It has been the chief part of their employment, in all ages, to counteract the effects of his Benevolence, by inflicting injustice, oppression, and torture upon each other; by maiming the human frame, burning cities and villages, turning fruitful fields into a wilderness, and, by every other act of violence, carrying death and destruction through the world. And if *water, air,* and the *light of heaven*, had been placed within the limits of their control, it is more than probable, that whole nations would have been occasionally deprived of these elements, so essential to human existence. Yet, notwithstanding the prevalence of such depraved dispositions, the streams of Divine benevolence toward our apostate race have never yet been interrupted. The earth has never stopped in its career, and thrown nature into a scene of confusion; the light of heaven has never ceased to illumine the world; the springs of water have never been dried up, nor has the fertile soil ceased to enrich the plains with golden harvests. God "hath not left himself without a witness" to his benevolence, in any age, in that he hath unceasingly bestowed on the inhabitants of the world, "rain from heaven, and fruitful seasons, filling their hearts with food and gladness." This is one of the characters of Deity which forms the most perfect contrast to the selfish and revengeful dispositions of man, which as far transcends human benevolence as the heavens in extent surpass the earth—a character calculated to excite our highest love and admiration, and which we are called upon, in the Sacred Oracles, to imitate and revere: "Be ye merciful, as your Father who is in heaven is merciful; for he maketh his sun to rise on the evil and on the good, and sendeth rain on the just and on the unjust." "O that men would praise the Lord for his goodness, and for his wonderful works to the children of men!"

\* Sulphuric acid consists of 75 parts *oxygen*, and 25 parts *nitrogen*, which form the constituent parts of the air we breathe, only in a different proportion. Were this proportion materially altered, we should feel the most excruciating pain in attempting to breathe it in some of its combinations.

From such considerations we learn, even from the system of nature, that *mercy* is an attribute of the Deity; for if mercy consists in bestowing favors on those who are unworthy, or who meri-

punishment, the greatest sinners in all ages have shared in it, and every individual of the human race, now existing, enjoys a certain portion of those comforts which flow from the benevolent arrangements which the Creator has established: "He maketh the sun to rise on the evil and on the good." Though the nations in ancient times, as well as at present, "walked in their own ways," indulging in impiety, falsehood, lewdness, war, devastations, revenge, abominable idolatries, and every other violation of his law, he still supported the functions of their animal frames, and caused the influences of the sun, the rains, and the dews, to descend upon their fields, that they might be refreshed with his bounty, and filled "with food and gladness." If mercy were not an essential attribute of the Deity, he would have cut them down in the midst of their first transgressions, shattered to pieces the globe on which they dwell, and buried them in eternal oblivion. But whether Divine mercy will extend to the final forgiveness of sin, and the communication of eternal happiness to such beings, can be learned only from the discoveries of revelation.

In relation to the *inferior animals*—the immense multitude of living creatures with which the earth is replenished is a striking evidence of the vast profusion of Divine Benevolence. More than a hundred thousand species of animated beings are dispersed through the different regions of the air, the water, and the earth, beside myriads which are invisible to the unassisted eye. To estimate the number of individuals belonging to any one species is beyond the power of man. What countless myriads of herrings, for example, are contained in a single shoal, which is frequently more than six miles long, and three miles broad! To estimate the number of individuals in all the different species, would therefore be as impossible as to count the grains of sand in the Arabian deserts. There is not a single spot in any region of the globe but what teems with animated beings. Yet all this vast assemblage of sensitive existence is amply provided for by the bountiful Creator. "These all wait upon him, and he giveth them their meat in due season." They enjoy not only life, but also a *happy* existence. The sportive motions and gesticulations of all the animal tribes—the birds skimming through the air, warbling in the groves, and perching on the trees—the beasts of the field bounding in the forests and through the lawns—the fishes sporting in the waters—the reptiles wriggling in the dust—and the winged insects, by a thousand wanton mazes—all declare that they are rejoicing in their existence, and in the exercise of those powers with which the Creator has furnished them. So that wherever we turn our eyes, we evidently perceive that "the earth is full of the goodness of the Lord," and that "his tender mercies are over all his works."

This subject is boundless; but it would be inconsistent with the limited plan of this work to enter into any particular details. And it is the less necessary, when we consider that every instance of Divine Wisdom, is at the same time, an instance of *benevolence*; for it is the ultimate object of all the wise contrivances in the system of Nature, that happiness may be communicated to the various ranks of sensitive and intelligent existence. *Goodness* chooses the *end*, and *wisdom* selects the most proper *means* for its accomplishment; so that these two attributes must always be considered in simultaneous operation. And therefore, the instances I have already specified of the wisdom and intelligence of the Creator may also be considered as exemplifications of Divine

Benevolence. I shall therefore conclude this topic with the following extract from Dr. PALEY:—

"Contrivance proves design; and the prominent tendency of the contrivance indicates the disposition of the designer. The world abounds with contrivances; and all the contrivances we are acquainted with are directed to beneficial purposes. Evil, no doubt, exists; but it is never, that we can perceive, the object of contrivance. Teeth are contrived to eat, not to ache; their aching now and then is incidental to the contrivance, perhaps inseparable from it; or even, if you will, let it be called a defect in the contrivance, but it is not the *object* of it. This is a distinction that well deserves to be attended to. In describing implements of husbandry, you would hardly say of a sickle, that it was made to cut the reaper's fingers, though from the construction of the instrument, and the manner of using it, this mischief often happens. But if you had occasion to describe instruments of torture or execution,—this, you would say, is to extend the sinews; this to dislocate the joints; this to break the bones; this to scorch the soles of the feet. Here pain and misery are the very *objects* of the contrivance. Now, nothing of this sort is to be found in the works of Nature. We never discover a train of contrivance to bring about an evil purpose. No anatomist ever discovered a system of organization calculated to produce pain and disease; or, in explaining the parts of the human body, ever said, this is to irritate; this to inflame; this duct is to convey the gravel to the kidneys; this gland to secrete the humor which forms the gout. If, by chance he come at a part of which he knows not the use, the most he can say is, that it is useless; no one ever suspects that it is put there to incommode, to annoy, or torment. Since, then, God hath called forth his consummate wisdom to contrive and provide for our happiness, and the world appears to have been constituted with this design at first, so long as this constitution is upheld by him, we must, in reason, suppose the same design to continue."\*

Thus I have endeavored, in this and the preceding section, to exhibit a few specimens of the Wisdom and Goodness of God in the system of nature. These might have been multiplied to an indefinite extent; but the instances adduced, I presume, are sufficient to show, that the economy of the material world is not altogether a barren subject to a pious and contemplative mind. Every intelligent believer in Revelation will readily admit, that it would be a highly desirable object, to induce upon the mass of Christians such a habit of devout attention to the visible works of creation, as would lead them, in their social and solitary walks, to recognize the agency of God in every object they behold; to raise their thoughts to him as the Great First Cause, and to expand their hearts with emotions of gratitude. How very different must be the sentiments and the pity of the man who looks on the scene of wisdom and magnificence around him with a "brute unconscious gaze," as thousands of professed Christians do—and the grateful and pious emotions of him who recognizes the benevolent agency of God in the motions of his fingers and eyeballs; in the pulsation of his heart; in the picture of external objects every moment formed on his retina; in the reflection of the rays of light, and the diversified colors they produce; in the drying of his clothes; in the constitution of the atmosphere; in the beauty and magnificence of the earth and the heavens; and in every other

\* Paley's Moral Philosophy, Book II, Chap. v.

object that meets his eye in the expanse of nature! The numberless astonishing instances of Divine agency, which everywhere present themselves to our view in the scene around us, seem evidently intended to arrest the mind to a consideration of

an "ever-present Deity;" and I envy not the sentiments or the feelings of that man, who imagines that he stands in no need of such sensible mediums, to impress his mind with a sense of the benevolent care and *omnipresence* of God

## CHAPTER II.

### CONTAINING A CURSORY VIEW OF SOME OF THE SCIENCES WHICH ARE RELATED TO RELIGION AND CHRISTIAN THEOLOGY.

THEOLOGY has generally been viewed as a study of a very limited range: and hence, when it has been admitted into the circle of the sciences, a much smaller space has been allotted for its discussion than has been devoted to almost any other department of human knowledge. When considered, however, in its most extensive sense—in its relations to the Divine Being—to his past and present dispensations toward the human race—to the present circumstances and the future destiny of man—and to the physical and moral condition of all the sentient and intelligent beings of which we have any intimation—it ought to be viewed as the most varied and comprehensive of all the sciences; as embracing, within its extensive grasp, all the other departments of useful knowledge both human and divine. As it has God for its object, it must include a knowledge of the universe he has formed—of the movements which are continually going on throughout the wide extent of his empire, in so far as they lie open to our inspection—of the attributes which appear to be displayed in all his operations—of the moral laws he has framed for the regulation of holy intelligences—of the merciful arrangements he has made for the restoration of fallen man—of the plans by which the knowledge of his will is to be circulated and extended in the world in which we live—of the means by which truth, and moral purity, and order, are to be promoted among our apostate race, in order to their restoration to the happiness they have lost—together with all those diversified ramifications of knowledge, which have either a more remote or a more immediate bearing on the grand objects now specified. Like the lines which proceed from the circumference to the center of an immense circle—all the *moral*\* arts and sciences which have been invented by men—every department of human knowledge, however far it may, at first sight, appear to be removed from religion—may be considered as having a direct bearing on Theology, as the grand central point, and as having a certain tendency to promote its important objects.

It is much to be regretted, that Theology has so seldom been contemplated in this point of view—and that the sciences have been considered rather as so many independent branches of secular knowledge, than as subservient to the elucidation of the facts and doctrines of religion, and to the accomplishment of its benevolent designs. Hence it has happened that Philosophy and Religion, instead of marching hand in hand to the

portals of immortality, have frequently set themselves in hostile array; and combats have ensued equally injurious to the interests of both parties. The Philosopher has occasionally been disposed to investigate the economy of Nature, without a reference to the attributes of that Almighty Being who presides over its movements, as if the universe were a self-moving and independent machine; and has, not unfrequently, taken occasion, from certain obscure and, insulated facts, to throw out insinuations hostile to the truth and the character of the Christian Revelation. The Theologian, on the other hand, in the heat of his intemperate zeal against the infidel philosopher, has unguardedly, been led to declaim against the study of science, as if it were unfriendly to religion—has, in effect, set the works of God in opposition to his word—has confounded the foolish theories of speculative minds with the rational study of the works of Deity—and has thus prevented the mass of mankind from expanding their minds, by the contemplation of the beauties and sublimities of nature.

It is now high time that a complete reconciliation were effected between these contending parties. Religion ought never to disdain to derive her supports and illustrations from the researches of science; for the investigations of philosophy into the economy of Nature, from whatever motives they may be undertaken, are nothing else than an inquiry into the plans and operations of the Eternal Mind. And Philosophy ought always to consider it as her highest honor to walk as a handmaid in the train of that religion which points out the path to the regions of eternal bliss. By their mutual aid, and the subserviency of the one to the other, the moral and intellectual improvement of man will be promoted, and the benevolent purposes of God in the kingdom of providence, gradually accomplished. But, when set in opposition to each other, the human mind is bewildered and retarded in its progress, and the Deity is apt to be considered as set in opposition to himself—as proclaiming one system of doctrines from the economy of revelation, and another, and an opposite system, from the economy of nature. But if the Christian Revelation, and the system of the material world, derived their origin from the same Almighty Being, the most complete harmony must subsist between the revelations they respectfully unfold; and the apparent inconsistencies which occur, must be owing chiefly to the circumstances of our present station in the universe, and to the obscure and limited views we are obliged to take of some of the grand and diversified objects they embrace. And therefore we have reason to believe, that when the system of nature shall be more extensively ex-

\* The epithet *moral* is here used in its application to arts, because there are certain arts which must be considered as having an *immoral* tendency, such as the art of war, the art of boxing, of gambling, etc., and which, therefore, cannot have a direct tendency to promote the objects of religion.

plored, and the leading objects of revelation contemplated in a clearer light, without being tinged with the false coloring of party opinions and contracted views, and when rational inquirers shall conduct their researches with a greater degree of reverence, humility, and Christian temper—the beauty and harmony of all the plans and revelations of the Deity, in reference both to the physical and the moral world, will be more distinctly perceived and appreciated.

In the following cursory sketches, it forms no part of my plan to trace even an *outline* of the different sciences which are connected with religion, much less to enter into any particular details in relation to their facts and principles. It would be comparatively easy to fill up the remaining sheets of this volume with skeletons of the different sciences; but such meager details as believed to be brought forward, could not be interesting to the general reader, and would fail in accomplishing the objects proposed. My design simply is, to select some leading facts, or general truths, in relation to some of the physical sciences, for the purpose of showing their connection with the objects of religion, and the interests of rational piety. At the same time, such definite descriptions will be given as will enable common readers to appreciate the objects and bearings of the different branches of knowledge which may be presented to their view.

The first science\* I shall notice, is that of

#### NATURAL HISTORY.

This science, taken in its most comprehensive sense, includes a knowledge and description of all the known facts in the material universe.

It is to be regretted, that most books published under the title of *Natural History*, to which common readers have access, contain nothing more than a general description of animals, as if this science were confined merely to one class of beings; whereas there is an infinite variety of other objects seldom noticed, which would appear no less interesting, and, in some instances, much more novel and gratifying to the general reader, and to the youthful mind. All the diversified forms of matter, whether existing on the surface or in the bowels of the earth, in the ocean, the atmosphere, or in the heavens, form the legitimate objects of this department of the science of nature.

Were we, therefore, to sketch a comprehensive outline of the subjects of Natural History, we might, in the first place, take a cursory survey of the globe we inhabit, in reference to its magnitude, figure, motions, and general arrangements—the form, relations, and extent of its continents—the numerous islands which diversify the surface of the ocean—the magnitude, the direction, and the extent of its rivers, and the quantity of water they pour into the ocean—the direction, elevation, and extent of the different ranges of mountains which rise from its surface—the plains, morasses, lakes, forests, dells, and sandy deserts, which diversify its aspect—the extent, the mo-

tions, the color, and the different aspects of the ocean, and the facts which have been ascertained respecting its saltness, its depth, its bottom, and its different currents. We might next take a more particular view of some of the most remarkable objects on its surface, and give a detail of the facts which are known respecting the history of *volcanoes*—their number—the countries in which they are situated—the awful phenomena they exhibit—and the devastations they have produced—the history of *earthquakes*, their phenomena and effects, and the countries most subject to their ravages—basaltic and rocky wonders, natural bridges, precipices, cataracts, ice islands, icebergs, glaciers, whirlpools, mineral wells, reciprocating fountains, boiling springs, sulphuric mountains, bituminous lakes, volcanic islands—the various aspects of nature in the different zones, and the contrasts presented between the verdant scenes of tropical climes, and the icy cliffs of the polar regions. We would next take a survey of the subterraneous wonders which lie beneath the surface of the earth—the immense chasms and caverns which wind in various directions among the interior strata of our globe—such as the great Kentucky cavern, and the grotto of Antiparos—the mines of salt, coal, copper, lead, diamond, iron, quicksilver, tin, gold, and silver—the substances which compose the various strata, the fossil bones, shells, and petrifications which are imbedded in the different layers, and the bendings and disruptions which appear to have taken place in the substances which compose the exterior crust of the earth. We might next survey the *atmosphere* with which the earth is environed, and give a detail of the facts which have been ascertained respecting its specific gravity and pressure, the elementary principles with which it is compounded, its refractive and reflective powers, and the phenomena which result from its various properties and modifications—the *meteors* which appear in its different regions—thunder and lightning, winds, hail, rain, clouds, rainbows, parhelia or mock-suns, meteoric stones, the aurora borealis, luminous arches, ignes fatui, the mirage, the fata morgana, hurricanes, monsoons, whirlwinds and waterspouts, sounds and echoes.

In prosecuting our survey of sublunary nature, we would next advert to the various orders of the *regetable tribes*—their anatomical structure—the circulation of their juices—the food by which they are nourished—the influence of light and air on their growth and motions—their male and female organs—their periods of longevity—their modes of propagation—their diseases and dissolution—their orders, genera, and species—their immense variety—their influence on the salubrity of the atmosphere—the relation which their trunks, roots, leaves, and fruits, bear to the wants of man and other animals, in supplying food, clothing, and materials for constructing habitations—the gums and resinous substances they exude—the odors they exhale—the variety of colors they exhibit—the vast diversity of forms in which they appear—and the beauty and variety which they spread over the whole face of nature.

The *mineral kingdom* would next require to be surveyed. We would inquire into the facts which have been ascertained respecting the *earthy, saline, inflammable, and metallic* substances, which are found on the surface and in the bowels of the earth—their specific and distinguishing characters—the elementary principles, or simple substances, of which they are composed—the regions of the earth where the respective minerals most fre-

\*The term *science*, in its most general and extensive sense, signifies *knowledge*, particularly that species of knowledge which is acquired by the exertion of the human faculties. In a more restricted sense, it denotes a *systematic* species of knowledge which consists of rule and order, such as Mathematics, Astronomy, Natural Philosophy, etc.—In the discussions contained in this work, it is used in its most general sense, as denoting the various departments of human knowledge; in which sense, history, both natural, civil, and sacred, may be termed *science*.

quently abound—and the ends which they are designed to accomplish in the constitution of the globe. We would consider, more particularly, the various metals, such as iron, copper, lead, tin, gold silver, bismuth, zinc, etc., in reference to the substances with which they are united in their native ores—the changes produced upon them by the action of oxygen and the different acids—their combustibility—their combination with phosphorus, sulphur, and carbon—the various compounds into which they may be formed—their important uses in the arts which minister to the comfort and embellishment of human life—their relation to the multifarious necessities of man—and the wisdom and goodness of the Creator, as displayed in their arrangement in the bowels of the earth, and in the admirable properties of which they are possessed. In these details, the natural history of *Iron* would hold a prominent place. In point of *utility*, it claims the highest rank in the class of metals, and is intrinsically more valuable than gold and silver, and all the diamonds of the East. There is scarcely a mineral substance in the whole compass of nature which affords a more striking instance of the beneficial and harmonious adaptation of things in the universal system. We would, therefore, consider it in reference to its vast abundance in all parts of the world—the numerous substances into which it enters into combination—its magnetical property—its capability of being fused and welded—the numerous useful utensils it has been the means of producing—its agency in carrying forward improvements in art and science, in the civilization of barbarous tribes, and in promoting the progress of the human mind; and the aids which it affords to the Christian missionary in heathen lands.

Having surveyed the inanimate parts of the terraqueous globe, and its appendages, we might next direct our attention to the animated tribes with which it is peopled. Beginning at *Man*, the head of the animal creation, we would detail the principal facts which have been ascertained respecting his structure and organical functions—the muscular movements of the human body, the system of bones, nerves, veins, and arteries; the process of respiration; and the organs of vision, hearing, smelling, tasting, and feeling, by which he holds a correspondence with the material world—the modifications which appear in his corporeal frame, and in his mental faculties, during the periods of infancy, puberty, manhood, and old age—the causes and phenomena of sleep and dreaming—the varieties of the human race, in respect of color, stature, and features—the deviations from the ordinary course of nature, which occasionally occur, in the case of monsters, dwarfs, and giants—the moral and intellectual faculties—and those distinguishing characteristics which prove the superiority of man over the other tribes of animated nature.

The inferior ranks of the animal creation would next demand our attention. We would take a survey of the numerous tribes of *Quadrupeds*, *Birds*, *Fishes*, *Serpents*, *Lizards*, and *Insects*, in reference to the characteristic marks by which the different species are distinguished,—their food, and habitations—the different modes in which they display their architectonic faculty, in constructing places of abode for shelter and protection—the clothing with which they are furnished—their sagacity in finding out the proper means for subsistence and self-preservation—their hostilities—their artifices in catching their prey, and escaping their enemies—their modes of propaga-

tion—their transformations from one state and form to another—their migrations to different countries and climates—their various instincts—their care in rearing and protecting their young—their passions, mental characters, and social dispositions—their language or modes of communication with each other—their capacities for instruction and improvement—their different powers of locomotion—the adaptation of all their organs to the purposes for which they seem intended—the indications they give of being possessed of moral dispositions and rational powers—their different periods of longevity, and the ends which they are intended to subserve in the system of nature. Along with these details, certain views might be exhibited of the various forms of sensitive life, and modes of existence, which obtain in those numerous species of animals which are invisible to the naked eye, and which the microscope discovers in almost every department of nature.

Having surveyed the objects which compose our sublunary system, we would next direct our view to the regions of the sky, and contemplate the facts which have been discovered in relation to the celestial orbs. We would first attend to the *apparent* motion of the sun, the different points of the horizon at which it seems to rise and set, and the different degrees of elevation to which it arrives, at different seasons of the year,—the different aspects it presents as viewed from different parts of the earth's surface, and the different lengths of days and nights, in different parts of the world. We would next attend to the varied phases of the moon—the direct and retrograde motions of the planets—the apparent diurnal motion of the whole celestial sphere, from east to west—and the different clusters of stars which are seen in our nocturnal sky, at different seasons of the year. We would next consider the deductions which science has made, respecting the order and arrangement of the planets which compose the solar system—their distances from the sun, and from the earth—their magnitudes—the periods of their diurnal and annual revolutions—the secondary planets, or moons, which accompany them—their eclipses—the various phenomena which their surfaces present when viewed through telescopes—the physical influence which some of them produce on the surface of our globe—and the singular appearance of those bodies called *Comets*, which occasionally visit this part of our system. We would, in the next place, extend our views to the starry regions, and consider the number of stars which present themselves to the naked eye—the immensely greater numbers which are discovered by telescopes—the systems into which they appear to be arranged—the facts which have been ascertained respecting *new stars*—double and treble stars—stars once visible, which have now disappeared from the heavens—variable stars, whose luster is increased and diminished at different periods of time—and the structure and position of the many hundreds of *Nebulae*, or starry systems, which appear to be dispersed throughout the immensity of creation.

All the particulars now stated, and many others which might have been specified—*considered simply as facts* which exist in the system of Nature—form the appropriate and legitimate objects of Natural History, and demand the serious attention of every rational intelligence, that wishes to trace the perfections and agency of the Almighty Creator. To investigate the *causes* of the diversified phenomena which the material world exhibits, and the principles and modes by which many of

the facts now alluded to are ascertained, is the peculiar province of Natural Philosophy, Chemistry, and the Mathematical Sciences.

Amidst so vast a variety of objects as Natural History presents, it is difficult to fix on any particular facts, as specimens of the interesting nature of this department of knowledge, without going beyond the limits to which I am necessarily confined in this volume. I shall content myself with a description of two objects, which have a reference chiefly to the vegetable kingdom. The first of these is

**THE BANIAN TREE.**—“This Tree, which is also called the *Burr tree*, or the *Indian Fig*, is one of the most curious and beautiful of Nature’s productions, in the genial climate of India, where she sports with the greatest variety and profusion. Each tree is in itself a grove; and some of them are of an amazing size and extent, and, contrary to most other animal and vegetable productions, seem to be exempted from decay. Every branch from the main body throws out its own roots; at first, in small tender fibers, several yards from the ground; these continually grow thicker, until, by a gradual descent, they reach the surface, and there, striking in, they increase to large trunks, and become parent trees, shooting out new branches from the tops. These in time suspend their roots, and, receiving nourishment from the earth, swell into trunks, and shoot forth other branches; thus continuing in a state of progression, so long as the earth, the first parent of them all, contributes her sustenance. A Banian tree, with many trunks, forms the most beautiful walks, vistas, and cool recesses, that can be imagined. The leaves are large, soft, and of a lively green, about six inches in length; the fruit is a small fig, when ripe, of a bright scarlet, affording

sustenance to monkeys, squirrels, peacocks, and birds of various kinds, which dwell among the branches.

“The Hindoos are peculiarly fond of the Banian Tree; they consider its long duration, its outstretching arms, and its overshadowing beneficence, as emblems of the Deity, and almost pay it divine honors. The Brahmins, who thus ‘find a fane in every sacred grove,’ spend much of their time in religious solitude, under the shade of the Banian tree; they plant it near their temples or pagodas; and in those villages where there is no structure erected for public worship, they place an image under one of these trees, and there perform a morning and evening sacrifice. The natives of all castes and tribes are fond of recreating in the cool recesses, beautiful walks, and lovely vistas of this umbrageous canopy, impervious to the hottest beams of a tropical sun. It is recorded that one of these trees shaded all the town of Fort St. David and Gombroon. These are the trees under which a sect of naked philosophers, called Gymnosophists, assembled in Arian’s days, and this historian of ancient Greece presents a true picture of the Modern Hindoos. ‘In winter,’ he says, ‘the Gymnosophists enjoy the benefit of the sun’s rays in the open air; and, in summer, when the heat becomes excessive, they pass their time in cool and moist places, under large trees, which, according to the accounts of Nearchus, cover a circumference of *five acres*, and extend their branches so far, that *ten thousand men* may easily find shelter under them.’

“On the banks of the river Narbudda, in the province of Guzzerat, is a Banian tree, supposed, by some persons to be the one described by Nearchus, who commanded the fleet of Alexander the Great, and certainly not inferior to it. It is dis-

Fig. 12.

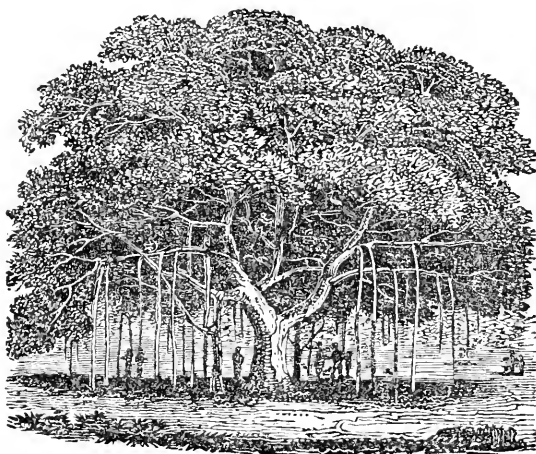

tinguished by the name of Cubbeer Burr, which was given it in honor of a famous saint. Forbes, in his ‘Oriental Memoirs,’ when speaking of the age of such trees, states that he smoked his hookha under the very Banian beneath which part of Alexander’s cavalry took shelter. High floods have, at various times, swept away a considerable part of this extraordinary tree; but what still remains is nearly *two thousand feet* in circumference, measured round the principal stems; the overhanging branches, not yet struck down, cover a much larger space; and under it grow a number of cus-

tard-apple and other fruit trees. The large trunks of this single tree amount to *three hundred and fifty*; and the smaller ones exceed three thousand; every one of these is constantly sending forth branches and hanging roots to form other trunks, and become the parents of a future progeny. The Cubbeer Burr is famed throughout Hindostan, not only on account of its great extent, but also of its surpassing beauty. The Indian armies generally encamp around it; and at stated seasons, solemn Jatarras, or Hindoo festivals, to which thousands of votaries repair from every part of the Mogul



empire, are there celebrated. It is said that seven thousand persons find ample room to repose under its shade. It has long been the custom of the British residents in India, on their hunting and shooting parties, to form extensive encampments, and spend weeks together, under this delightful and magnificent pavilion, which affords a shelter to all travelers, particularly to the religious tribes of the Hindoos. It is generally filled with green wood-pigeons, doves, peacocks, and a variety of feathered songsters—with monkeys, which both divert the spectator by their antic tricks, and interest him by the parental affection they display to their young offspring, in teaching them to select their food, and to exert themselves in jumping from bough to bough,—and is shaded by bats of a large size, many of them measuring upward of six feet from the extremity of one wing to the other. This tree affords not only shelter, but also sustenance, to all its inhabitants, being covered, amid its bright foliage, with small figs, of a rich scarlet, on which they all regale with as much delight as the lords of creation on their more costly fare, in their parties of pleasure."

The preceding figure will convey a general, though imperfect, idea of this singular tree, and of the manner in which the branches from the main body throw out their shoots, and form the numerous vista, which are found under its shade.

This tree, which is doubtless one of the most singular and magnificent objects in the vegetable kingdom, appears to be a world in miniature, in which thousands, both of human beings, and of the inferior tribes that traverse the earth and the air, may find ample accommodation and subsistence. What a striking contrast does it present to the forests of trees, or mushrooms, which are perceived by the help of the microscope, in a piece of *moldiness*—every plant of which is several hundreds of times smaller than the point of a fine needle! Yet both are the effects of the agency of the same All-wise and Omnipotent Being. And what an immense variety of gradations is to be found in the vegetable world, between these two extremes—every part of the vast interval being filled up with flowers, herbs, shrubs, and trees, of every color, form, and size, and in such vast multitudes and profusion that no man can number them!

An object which approximates in a certain degree to the one now described, is mentioned in "Stanton's Account of Macartney's Embassy to China," p. 70. It is called by Botanists, *Adansonia*, and is also known by the name of the *Monkey Bread Tree*, and was discovered in the Island of St. Jago. "The circumference or girth of the base was 56 feet, which soon divided into two vast branches, the one in a perpendicular direction, whose periphery, or girth, was 42 feet, the other 26. Another, of the same species, stood near it, whose single trunk, girthing 38 feet, was scarcely noticed."

The only other specimen I shall exhibit to the reader, has a relation both to the animal and to the vegetable kingdom. It is well known that the examination of flowers, and vegetables, of every description, by the microscope, opens a new and interesting field of wonders to the inquiring naturalist. Sir JOHN HILL has given the following curious account of what appeared on his examining a carnation:—

"The principal flower in an elegant bouquet was a carnation: the fragrance of this led me to enjoy it frequently and near. The sense of smelling was not the only one affected on these occasions: while that was satiated with the powerful

sweet, the ear was constantly attacked by an extremely soft, but agreeable murmuring sound. It was easy to know, that some animal within the covert must be the musician, and that the little noise must come from some little creature suited to produce it. I instantly distended the lower part of the flower, and placing it in a full light, could discover troops of little insects frisking, with wild jollity, among the narrow pedestals that supported its leaves, and the little threads that occupied its center. What a fragrant world for their habitation! What a perfect security from all annoyance, in the dusky husk that surrounded the scene of action! Adapting a microscope to take in, at one view, the whole base of the flower, I gave myself an opportunity of contemplating what they were about, and this for many days together, without giving them the least disturbance. Thus, I could discover their economy, their passions, and their enjoyments. The microscope, on this occasion, had given what nature seemed to have denied to the objects of contemplation. The base of the flower extended itself, under its influence, to a vast plain; the slender stems of the leaves became trunks of so many stately cedars; the threads in the middle seemed columns of massy structure, supporting at the top their several ornaments; and the narrow spaces between were enlarged in walks, parterres, and terraces.

On the polished bottoms of these, brighter than Parian marble, walked in pairs, alone or in larger companies, the winged inhabitants; these, from little dusky flies, for such only the naked eye would have shown them, were raised to glorious glittering animals, stained with living purple, and with a glossy gold, that would have made all the labors of the loom contemptible in the comparison.—I could, at leisure, as they walked together, admire their elegant limbs, their velvet shoulders, and their silken wings; their backs vying with the empyrean in its blue; and their eyes, each formed of a thousand others, out-glittering the little planes on a brilliant; above description, and too great almost for admiration. I could observe them here singling out their favorite females; courting them with the music of their buzzing wings, with little songs, formed for their little organs, leading them from walk to walk, among the perfumed shades, and pointing out to their taste, the drop of liquid nectar, just bursting from some vein within the living trunk—here were the perfumed groves, the more than mystic shades of the poet's fancy realized. Here the happy lovers spent their days in joyful dalliance, or in the triumph of their little hearts, skipped after one another, from stem to stem, among the painted trees, or winged their short flight to the close shadow of some broader leaf, to revel undisturbed in the heights of all felicity."

This picture of the splendor and felicity of insect life, may, to certain readers, appear somewhat overcharged. But those who have been much in the habit of contemplating the beauties of the animal and vegetable world, through microscopes, can easily enter into all the views which are here described. I have selected this example, for the purpose of illustrating the unbounded goodness of the Creator, in the vast profusion of enjoyment he has communicated even to the lowest tribes of animal existence, and as a specimen of those invisible worlds which exist beyond the range of our natural vision. For it appears, that there is a gradation of worlds downward, as well as upward. However small our globe may appear when compared with the sun, and with the immensity of stary systems which lie dispersed

through the infinity of space, there are worlds filled with myriads of living beings, which, in point of size and extent, bear as small a proportion to the earth, as the earth bears to the vast assemblage of the celestial worlds. A single flower, a leaf, or a drop of water, may appear as large, and as diversified in its structure, to some of the beings which inhabit it, as the whole earth appears to the view of man: and a thousand scenes of magnificence and beauty may be presented to their sight, of which no distinct conception can be formed by the human mind. The many thousands of transparent globes, of which their eyes are composed, may magnify and multiply the objects around them without end, so that an object scarcely visible to the eye of man, may appear to them as a vast extended universe.

"Having examined," says ST. PIERRE, "one day, by a microscope, the flowers of thyme. I distinguished in them, with equal surprise and delight, superb flagons with long necks, of a substance resembling the amethyst, from the gullets of which seemed to flow ingots of liquid gold. I have never made observations of the *corolla*, simply of the smallest flower, without finding it composed of an admirable substance, half transparent, studded with brilliants, and shining in the most lively colors. The beings which live under a reflex thus enriched must have ideas very different from ours, of light, and of the other phenomena of nature. A drop of dew, filtering in the capillary and transparent tubes of a plant, presents to them thousands of cascades; the same drop fixed as a wave on the extremity of one of its prickles,—an ocean without a shore; evaporated into air, a vast aerial sea.—It is credible, then, from analogy, that there are animals feeding on the leaves of plants, like the cattle in our meadows and on our mountains, which repose under the shade of a down imperceptible to the naked eye, and which, from goblets formed like so many suns, quaff nectar of the color of gold and silver."

Thus it appears that the universe extends to infinity on either hand; and that wherever matter exists, from the ponderous globes of heaven down to the invisible atom, there the Almighty Creator has prepared habitations for countless orders of existence, from the seraph to the animalcule, in order to demonstrate his boundless beneficence, and the infinite variety of modes by which he can diffuse happiness through the universal system.

"How sweet to muse upon His skill, display'd—  
Infinite skill!—in all that has been made,  
To trace in Nature's most minute design,  
The signature and stamp of Power Divine;  
Contrivance exquisite, express'd with ease,  
Where unassisted sight no beauty sees;  
The shapely limb and lubricated joint,  
Within the small dimensions of a point;  
Muscle and nerve miraculously spun,  
His mighty work; who speaks and it is done:  
Th' Invisible in things scarce seen reveal'd;  
To whom an atom is an ample field!"—COWPER.

With regard to the *religious* tendency of the study of Natural History, it may be remarked, that as all the objects which it embraces are the *workmanship of God*, the delineations and descriptions of the Natural Historian must be considered as "the history of the operations of the Creator;" or, in other words, so far as the science extends, "the history of the Creator himself;" for the marks of his incessant agency, his power, wisdom, and beneficence, are impressed on every object, however minute, throughout the three kingdoms of nature, and throughout every region of earth, air, and sky. As the Deity is invisible to mortal eyes, and cannot be directly contempla-

ted by finite minds, without some material medium of communication, there are but two mediums with which we are acquainted by which we can attain a knowledge of his nature and perfections. These are, either the *facts* which have occurred in the course of his providential dispensations toward our race, since the commencement of time, and the moral truths connected with them—or the facts which are displayed in the economy of nature. The first class of facts is recorded in the Sacred History; and in the Annals of Nations; the second class is exhibited in the diversified objects and motions which appear throughout the system of the visible universe. The one may be termed the *Moral History*, and the other the *Natural History* of the operations of the Creator. It is obviously incumbent on every rational being to contemplate the Creator through both these mediums, for each of them conveys its distinct and peculiar revelations; and, consequently, our perception of Deity through the one medium does not supersede the necessity of our contemplating him through the other. While, therefore, it is our duty to contemplate the perfections, the providence, and the agency of God, as displayed in the Scripture-revelation, it is also incumbent upon us to trace his attributes in the system of Nature, in order that we may be enabled to contemplate the Eternal Jehovah, *in every variety of aspect* in which he has been pleased to exhibit himself in the universe he has formed.

The visible creation may be considered as a permanent and sensible manifestation of Deity; intended every moment to present to our view the unceasing energies of Him "in whom we live and move." And if the train of our thoughts were directed in its proper channel, we would perceive God in every object and in every movement; we would behold him operating in the whirlwind and in the storm; in the subterraneous cavern and in the depths of the ocean; in the gentle rain and the refreshing breeze; in the rainbow, the fiery meteor, and the lightning's flash; in the splendors of the sun and the majestic movements of the heavens; in the frisking of the lambs, the songs of birds, and the buzz of insects; in the circulation of our blood, the movements of our joints, the motion of our eye-balls, and in the rays of light which are continually darting from surrounding objects, for the purposes of vision. For these and ten thousand other agencies in the system of nature, are nothing else but the voice of Deity, proclaiming to the sons of men, in silent but emphatic language, "Stand still, and consider the wonderful works of God."

If, then, it be admitted that the study of Nature is the study of the Creator—to overlook the grand and beautiful scenery with which we are surrounded, or to undervalue anything which Infinite Wisdom has formed, is to overlook and contemn the Creator himself. Whatever God has thought proper to create, and to present to our view in the visible world, it becomes man to study and contemplate, that from thence he may derive motives to excite him to the exercise of reverence and adoration, of gratitude and praise. In so far as any individual is unacquainted with the various facts of the history of nature, in so far does he remain ignorant of the manifestations of Deity; for every object on the theater of the universe exhibits his character and designs in a different point of view. He who sees God only as he displays himself in his operations on the earth, but has never contemplated the firmament with the eye of reason, must be unacquainted with those

amazing energies of eternal Power, which are displayed in the stupendous fabric and movements of the orbs of heaven. He who sees God only in the general appearances of nature, but neglects to penetrate into his minute operations, must remain ignorant of those astonishing manifestations of Divine wisdom and skill, which appear in the contrivances, adaptations, and functions of the animal and the vegetable kingdoms. For the more we know of the work, the more accurate and comprehensive will be our views of the Intelligence by whom it was designed; and the farther we carry our investigations of the works of God, the more admirable and astonishing will his plans and perfections appear.

In short, a devout contemplation of the works of nature tends to enoble the human soul, and to purify and exalt the affections. It inspires the mind with a relish for the beauty, the harmony, and order, which subsist in the universe around us—it elevates the soul to the love and admiration of that Being who is the Author of all our comforts and of all that is sublime and beneficent in creation, and excites us to join with all holy beings in a chorus of praise to the God and Father of all. For they

“Whom nature’s works can charm, with God himself  
Hold converse, grow familiar day by day  
With his conceptions, act upon his plan,  
And form to his the relish of their souls.”

The man who surveys the vast field of nature with the eye of reason and devotion, will not only acquire a more comprehensive view of that illimitable power which organized the universe, but will find his sources of enjoyment continually increased, and will feel an ardent desire after that glorious world, where the veil which now hides from our sight some of the grandest manifestations of Deity will be withdrawn, and the wonders of Omnipotence be displayed in all their splendor and perfection.

In conformity with these sentiments, we find the inspired writers, in numerous instances, calling our attention to the wonders of creating power and wisdom. In one of the first speeches in which the Almighty is introduced as addressing the sons of men, and the longest one in the Bible,\* our attention is exclusively directed to the subjects of Natural History;—the whole address having a reference to the economy of Divine Wisdom in the arrangement of the world at its first creation—the wonders of the ocean, and of light and darkness—the phenomena of thunder and lightning, rain, hail, snow, frost, and other meteors in the atmosphere—the intellectual faculties of man, and the economy and instincts of quadrupeds, birds, fishes, and other tribes of animated existence. Indeed, the greater part of the sublime descriptions contained in the book of Job has a direct reference to the agency of God in the material creation, and to the course of his providence in relation to the different characters of men; and the reasonings of the different speakers in that sacred drama, proceed on the supposition, that their auditors were intimately acquainted with the varied appearances of nature, and their tendency to exhibit the character and perfections of the Omnipotent Creator. We find the Psalmist, in Psalm civ, employed in a devout description of similar objects, from the contemplation of which his mind is raised to adoring views of their Almighty Author—and, from the whole of his survey, he deduces the following conclusions:—“How

manifold are thy works, O Lord! *In wisdom* thou hast made them all! The earth is full of thy riches; so is this great and wide sea, wherein are things creeping innumerable, both small and great beasts. The glory of the Lord shall endure forever; the Lord shall rejoice in all his works.\* I will sing unto the Lord as long as I live; I will sing praises to my God while I have my being.”

But in order to enter into the spirit of such sublime reflections, we must not content ourselves with a superficial and cursory view of the objects and operations of nature,—we must not think it sufficient to acquiesce in such vague propositions as these: “The glory of God is seen in every blade of grass, and every drop of water; all nature is full of wonders, from the dust of the earth to the stars of the firmament.” We must study the works of creation with ardor, survey them with minute attention, and endeavor to acquire a *specific* and *comprehensive* knowledge of the Creator’s designs. We must endeavor to acquire a knowledge of the particular modes, circumstances, contexture, configurations, adaptations, structure, functions, and relations of those objects in which benevolence and design conspicuously appear—in the animal and the vegetable world, in the ocean, the atmosphere, and the heavens; that the mind may be enabled to draw the conclusion with full conviction and intelligence—“*In wisdom thou hast made them all!*” The pointed interrogatories which Jehovah addressed to Job, evidently imply that Job had previously acquired an intimate acquaintance with the works of nature. It seems to be taken for granted, as a matter of course, that he had made himself acquainted with the general range of facts in the visible creation; and the intention of the several questions presented to his consideration evidently was, to impress him with a sense of his own impotency, and to lead him to the investigation of the wonders of Creating Power, which he had formerly overlooked. The conclusion which the Psalmist draws respecting the *Wisdom* displayed throughout all the works of God, plainly intimates, that he had made the different parts of nature the subject of minute examination and of deep reflection; otherwise he could not have rationally deduced his conclusion, or felt those emotions which filled his mind with the pious raptures so beautifully expressed in that hymn of praise to the Creator of the world.

We have therefore reason to believe, from these and other instances, that pious men, “in the days of old,” were much more accustomed than modern Christians to contemplate and admire the visible works of the Lord; and it is surely much to be regretted, that we, who enjoy so many superior means of information, and who have access to the brilliant discoveries of later and more enlightened times, should manifest so much disregard to “the works of Jehovah, and the operations of his hands.” To enable the common mass of Christians to enter into the spirit of this delightful study and *Christian duty*, should, there-

\* The *glory* of the Lord, in this passage, denotes the display of his perfections in the material universe; and the declaration of the inspired writer plainly intimates, that this display will continue forever, and will remain as an object of unceasing contemplation to all intelligences, and as an eternal monument of his Power and Wisdom. For although the earth and the aerial heavens will be changed at the close of that dispensation of Providence which respects our world, yet the general frame of the universe, in its other parts, will remain substantially the same; and not only so, but will, in all probability, be perpetually increasing in magnitude and grandeur. And the change which will be effected in respect to the terrestrial globe and its appendages will be such that Jehovah will have reason to “rejoice” in this, as well as in all his other works.

\* Job, chap. xxxviii, xxxix, xl, xli.

fore, be one object of those periodical and other religious works which are put into their hands; so that they may be enabled, with vigor and intelligence, to form the pious resolution of Asaph, "I will meditate on all thy works, O Lord! and talk of thy doings." "I will utter abundantly the memory of thy great goodness, and tell of all thy wondrous works."

## GEOGRAPHY.

The next department of knowledge I shall notice is the science of Geography.

The object of this science is, to describe the world we inhabit, in reference to the continents, islands, mountains, oceans, seas, rivers, empires, and kingdoms with which it is diversified, together with the manners, customs, and religion of the different tribes which people its surface.

In order to form an accurate conception of the relative positions of objects on the surface of the earth, and to enter, with intelligence, on the study of this subject, it is requisite, first of all, to have an accurate idea of its *figure and magnitude*. For a long series of ages, it was supposed, by the bulk of mankind, that the surface of the earth was nearly a plane, indefinitely extended, and bounded on all sides by the sky. Lactantius, and several of the Fathers of the Christian Church, strenuously argued, that the earth was extended infinitely downward, and established upon several foundations. The ancient philosopher Heraclitus is said to have believed, that the earth was of the shape of a skiff or canoe, very much hollowed; and the philosopher Leucippus supposed it to be of the form of a cylinder or a drum. It is only within the period of the last three hundred years that the true figure of the earth has been accurately ascertained. This figure is now found to be that of an oblate spheroid, nearly approaching to the shape of a globe or sphere. To have asserted this opinion several ages ago would have been considered as a heresy in religion, and would have subjected its abettors to the anathemas of the Church, and even to the peril of their lives. Historians inform us, that the learned Spigelius, bishop of Upsal, in Sweden, suffered martyrdom at the stake, in defense of the doctrine of the *Antipodes*; and we know that, for asserting the motion of the earth, the celebrated philosopher Galileo was immured in a dungeon, and condemned by an assembly of Cardinals, to all the horrors of perpetual imprisonment. The doctrine he maintained, and which is now universally received by every one acquainted with the subject, was declared by those arrogant ecclesiastics to be "a proposition absurd in its very nature, false in philosophy, heretical in religion, and contrary to the Holy Scriptures." Such are some of the horrible and pernicious consequences which flow from ignorance of the phenomena of nature, and of those laws by which the Almighty governs the universe he has formed; and which prove it to be a Christian duty for every rational being to study the order and economy of the visible world.

That the earth is nearly of a globular figure is proved by the following considerations:—1. When we stand on the sea-shore, while the sea is perfectly calm, we perceive that the surface of the water is not quite plane, but convex or rounded; and if we are on one side of an arm of the sea, as the Frith of Forth, and with our eyes near the water, look toward the opposite coast, we shall plainly see the water elevated between our eyes and the opposite shore, so as to prevent our seeing the land near the edge of the water. The same

experiment may be made on any portion of still water, of a mile or two in extent, when its convexity will be perceived by the eye. A little boat, for instance, may be perceived by a man who is any height above the water, but if he stoops down and lays his eye near the surface, he will find that the fluid appears to rise, and intercept the view of the boat. 2. If we take our station on the sea shore, and view the ships leaving the coast, in any direction—as they retire from our view, we may perceive the masts and rigging of the vessels when the hulls are out of sight, and, as it were, sunk on the water. On the other hand, when a ship is approaching the shore, the first part of her that is seen is the topmast; as she approaches nearer, the sails become visible, and, last of all, the hull comes gradually into view. The reason of such appearances obviously is, that the round or convex surface of the water interposes between our eye and the body of the ship, when she has reached a certain distance, while, at the same time, the sails and topmast, from their great elevation, may be still in view. To the same cause it is owing, that the higher the eye is placed, the more extensive is the prospect; and hence it is common for sailors to climb to the top of masts, in order to discover land or ships at a distance. The contrary of all this would take place, if the earth and waters were an extended plane. When a ship came within view, the hull would first make its appearance, being the largest object, next the sails, and last of all the topmast. These considerations, which hold true in all parts of the world, prove to a certainty, that the mass of the ocean is of a globular form; and if the ocean be a portion of a sphere, it follows, that the *land* also is of the same general figure; for no portion of the earth's surface is elevated above four or five miles above the level of the ocean. 3. That the earth is round from north to south, appears from the following circumstances:—When we travel a considerable distance from north to south, or from south to north, a number of new stars successively appear in the heavens, in the quarter to which we are advancing, and many of those in the opposite quarter gradually disappear, which would not happen if the earth were a plane in that direction. 4. That the earth is round from east to west, appears from actual experiment; for many navigators, by sailing in a westerly direction, have gone quite round it, from east to west; and were it not for the frozen seas, within the polar regions, which interrupt navigation in those directions, it would, long ere now, have been circumnavigated from north to south. 5. All these proofs are confirmed and illustrated by eclipses of the moon, which present an *ocular demonstration* of the earth's roundness. An eclipse of the moon is caused by the intervention of the body of the earth between the sun and the moon; in which case, the shadow of the earth falls upon the moon. This shadow is found in all cases, and in every position of the earth, to be of a *circular* figure; which incontrovertibly proves that the whole mass of land and water, of which the earth is composed, is nearly of a globular form. The mountains and vales which diversify its surface, detract little or nothing from its globular shape; for they bear no more proportion to its whole bulk than a few grains of sand to a common terrestrial globe; the highest mountains on its surface being little more than the two-thousandth part of its diameter. Some of the moun-

\* In order to make such observations to advantage, the observer's eye should be, as near as possible, on a level with the sea, and he should use a telescope to enable him to perceive more distinctly the upper parts of the vessel.

tains on the surface of the moon are higher than those on the earth, and yet that body appears, both to the naked eye and through telescopes, of a spherical figure.

To some readers, the discovery of the true figure of the earth may appear as a matter of very trivial importance in religion. I hesitate not, however, to affirm, that it constitutes a most important fact in the history of Divine Providence. Had not this discovery been made, it is probable that the vast continent of America might yet have remained undiscovered; for Columbus, who first discovered that new world, had learned, contrary to the general opinion of those times, that the earth was of a spherical figure; and, from the maps then existing, he began to conjecture that the nearest way of sailing to the East Indies would be to sail westward. And although he missed the object of his research, he was the means of laying open to view a vast and unknown region of the earth, destined, in due time, to receive from the eastern world the blessings of knowledge, civilization, and religion. On the knowledge of the spherical figure of the earth, the art of navigation in a great measure depends; and all the voyages of discovery which have been made in later years, were undertaken in consequence of the knowledge of this fact. Had mankind remained unacquainted with this discovery, the circumnavigation of the globe would never have been attempted—vast portions of the habitable world would have remained unknown and unexplored—no regular intercourse would have been maintained between the various tribes of the human race, and consequently, the blessings of Divine Revelation could never have been communicated to the greater part of the Gentile world. Beside, the knowledge of the true figure and magnitude of our sublunary world forms the groundwork of all the sublime discoveries which have hitherto been made in the regions of the firmament. For its diameter forms the *base-line* of those triangles by which the distances and magnitudes of the celestial globes have been determined,\*

\* In order that the general reader may understand what is meant by "the diameter of the earth forming the *base-line* of those triangles by which the distances, etc. of the heavenly bodies are measured," it may not be unnecessary to state the following explanations.

In any triangle, as  $A B C$ , if the length of the side  $A B$  be known, and likewise the quantity of the angles at  $A$  and  $B$ , or the number of degrees or minutes they subtend, be ascertained, we can find the length of the sides  $A C$  and  $B C$ . If  $A B$  represent a horizontal plane, 100 feet in extent, and  $C B$  a tower whose height we wish to determine, and  $\hat{A}$ , with a quadrant, we find the angle at  $A$ , or  $C A B$ , to be  $43$  degrees; then by an easy trigonometrical process—Radius: is to the tangent of  $A$ ,  $43^\circ$ : as the side  $A B$ , 100 feet: is to the height of the tower  $C B$ , which, in this case, will be found to be  $93\frac{3}{4}$  feet.

Fig. 13.

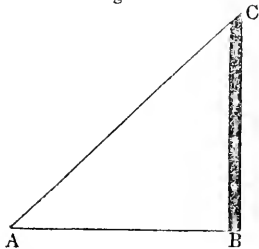

It is on this general principle that the distances and magnitudes of the celestial bodies are determined. But, in all cases where we wish to ascertain the dimensions of the different parts of a triangle—one side, at least, must be given,

without a knowledge of the extent of which, the important results which have been deduced respecting the system of the universe, could not have been ascertained, and consequently, our views of the grandeur and omnipotence of the Deity, and of the magnificence and extent of his dominions, must have been much more circumscribed than they now are. Such is the intimate connection that subsists between every part of the chain of Divine dispensations, that if any one link had been either broken or dissolved, the state of things, in the moral and intellectual world, would have been very different from what it now is; and the plans of Providence, for accomplishing the renovation and improvement of mankind, would have been either partially or totally frustrated.

With regard to the *magnitude* of the earth—I have already stated the mode by which we may acquire the most accurate and comprehensive conception of this particular, in the course of the illustrations that were given of the Omnipotence of Deity—(pp. 15-17). It is necessary here only to remark that, according to the latest computations, the diameter of the earth is about 7930 miles, and its circumference 24,912 miles; and consequently, the whole surface of the land and water it contains comprehends an area of 197,552,160 miles. The proportion of land and water on its surface cannot be very accurately ascertained; but it is quite evident, from an inspection of a map of the world, that the water occupies at

along with two angles, otherwise the length of the different sides of the triangle cannot be determined.—Now, in measuring the distance of a heavenly body, such as the Moon, the diameter or *semidiameter* of the earth is the *known side* of the triangle by which such a distance is to be found. In Fig. 14, let  $E C$  represent the Earth,  $M$  the Moon, and  $A B$

Fig. 14.

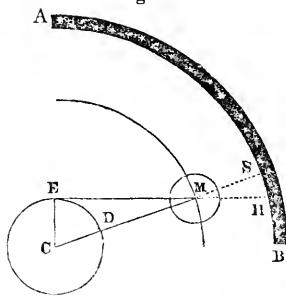

a portion of the starry firmament. If a spectator at the earth's surface at  $E$  view the moon in the horizon, it will appear in the line  $E M$ , among the stars at  $H$ . But, if viewed from the center of the earth at  $C$  or from the surface at  $D$ , it will appear in the line  $C D M$ , among the stars at  $S$ . The difference of position in which the moon is seen, as viewed from the surface of the earth  $E$ , and the center  $C$ , is called the moon's horizontal parallax, or the arc  $S H$ , which is subtended by the angle  $S M H$ , which is equal to the angle  $E M C$ . In determining the distance of the moon therefore, we must first find, by observation, the horizontal parallax, or, in other words, the angle  $E M C$ ; and the side  $E C$ , or the semidiameter of the earth being known to be about 4060 miles in extent, forms the *base-line* of the triangle  $E M C$ , and hence the other sides of the triangle  $E M$  and  $C M$ , or the distance of the moon from the earth, can be found by an easy calculation.

From what has been now stated it will appear that, were we ignorant of the figure and magnitude of the earth, we could not ascertain the distance of the moon or any other celestial body. In the above explanation I have merely stated the principle on which astronomers proceed in measuring the distances of bodies in the heavens, without descending into details. For a more particular explanation and illustration of this subject, the reader is referred to the author's work entitled "Celestial Surveying," chap. vii, where the subject is pretty fully and popularly treated.

least two-thirds of its surface, and of course the land cannot occupy more than one-third. Supposing it to be only one-fourth of the earth's surface, it will contain 49,388,049 square miles, which is considerably more than what is stated in most of our late systems of Geography; in some of which the extent of the land is rated at 39 millions, and in others so low as 30 millions of square miles—the former of which statements being less than one-fifth, and the latter less than one-sixth of the surface of the globe. But it is quite obvious that the extent of the land cannot be less than one-fourth of the area of the globe, and must, therefore, comprehend at least about 50 millions of square miles. And if a large arctic continent, eleven hundred leagues in length, exist around the North Pole, as some French philosophers infer, from Captain Parry's late discoveries\*—the quantity of land on the terraqueous globe will be much greater than what has now been stated.

**GENERAL DIVISIONS OF THE EARTH.**—The surface of the earth is divided, from north to south, by two bands of earth, and two of water. The first band of earth is the ancient or Eastern Continent, comprehending Europe, Asia, and Africa; the greatest length of which is found to be in a line beginning on the east point of the northern part of Tartary, and extending from thence to the Cape of Good Hope, which measures about 10,000 miles, in a direction nearly from north-east to south-west; but if measured according to the meridians, or from north to south, it extends only 7500 miles, from the northernmost cape in Lapland to the Cape of Good Hope. This vast body of land contains about 36 millions of square miles, forming nearly one-fifth of the whole surface of the globe. The other band of earth is what is commonly called the New Continent, which comprehends North and South America. Its greatest length lies in a line beginning at the south of the river Plata, passing through the island of Jamaica, and terminating beyond Hudson's Bay; and it measures about 8000 miles. This body of land contains about 14 millions of square miles, or somewhat more than a third of the Old Continent.

It may not be improper here to remark, that the two lines now mentioned, which measure the greatest length of the two continents, divide them into two equal parts, so that an equal portion of land lies on each side of these lines, and that each of the lines has an inclination of about 30 degrees to the equator, but in opposite directions; that of the old continent extending from the north-east to the south-west; and that of the new continent, from the north-west to the south-east; and that they both terminate at the same degree of northern and southern latitude. It may also be noticed, that the old and new continents are almost opposite to each other, and that the old is more extensive to the north of the equator, and the new more extensive to the south. The center of the old continent is in the 17th degree of north latitude, and the center of the new, in the 17th degree of south latitude; so that they seem to be made to counterbalance each other, in order to preserve the equability of the diurnal rotation of the earth. There is also a singular connection between the two continents, namely, that if they were divided into two parts, all four would be surrounded by the sea, were it not for the two small necks of land called the isthmuses of Suez and Panama.†

Between the two continents now mentioned lie

two immense bands of water, termed the Pacific and the Atlantic oceans, whose greatest length is likewise in a direction from north to south.

Beside the two bands of earth to which I have adverted, many extensive portions of land are dispersed through the ocean, which covers the remaining part of the earth's surface; particularly the extensive regions of New Holland, which occupy a space nearly as large as the whole of Europe, and the Arctic continent, which probably exists within the North Polar regions, and which some French writers propose to designate by the name of *Boreasia*, is, in all probability, of equal extent. There are also the extensive islands of New Guinea, Borneo, Madagascar, Sumatra, Japan, Great Britain, New Zealand, Ceylon, Iceland, Cuba, Java, and thousands of others, of different dimensions, scattered through the Pacific, the Indian, and the Atlantic oceans, and which form a very considerable portion of the habitable regions of the globe.

**GENERAL FEATURES OF THE EARTH'S SURFACE.**—In taking a general survey of the external features of the earth, the most prominent objects that strike the eye, are those huge elevations which rise above the level of its general surface, termed *Hills* and *Mountains*. These are distributed in various forms and sizes, through every portion of the continents and islands; and, running into immense chains, form a sort of connecting band to the other portions of the earth's surface. The largest mountains are generally formed into immense chains, which extend, in nearly the same direction, for several hundreds and even thousands of miles. It has been observed, by some philosophers, that the most lofty mountains form two immense ridges or belts, which, with some interruptions, extend around the whole globe in nearly the same direction. One of these ridges lies between the 45th and 55th degrees of north latitude. Beginning on the western shores of France and Spain, it extends eastward, including the Alps and the Pyrenees, in Europe; the Uralian and Altic mountains, in Asia—extending from thence to the shores of Kamtschatka, and, after a short interruption from the sea, they rise again on the western coast of America, and terminate at Canada, near the eastern shore. It is supposed that the Chain is continued completely round the globe, through the space that is covered by the Atlantic ocean, and that the Azores, and other islands in that direction, are the only summits that are visible, until we come to the British isles. The other ridge runs along the southern hemisphere, between the 20th and 30th degrees of south latitude, of which detached portions are found in the mountains of Tucuman and of Paraguay, in South America; of Monomotapa and Caffraria, in Africa; in New Holland, New Caledonia, the New Hebrides, the Friendly, the Society, and other islands in the Pacific ocean. From these ridges flow a variety of ramifications in both hemispheres, toward the Equator and the Poles, which altogether present a magnificent scenery, which diversifies and enlivens the surface of our globe.

The highest mountains in the world, according to some late accounts published in the "Transactions of the Asiatic Society," are the *Himalaya* chain, north of Bengal, on the borders of Tibet. The highest mountain in this range is stated to be about 27,000 feet, or a little more than five miles in perpendicular height, and is visible at the distance of 230 miles. Nineteen different mountains in this chain are stated to be above four miles in perpendicular elevation. Next to the

\* See Monthly Magazine, April, 1823, p. 259.

† See Buffon's Natural History, vol. i.

Himalayas are the Andes, in South America, which extend more than 4000 miles in length, from the province of Quito to the straits of Magellan. The highest summit of the Andes is Chimboracco, which is said to be 20,600 feet, or nearly four miles, above the level of the sea. The highest mountains in Europe are the Alps, which run through Switzerland and the north of Italy,—the Pyrenees, which separate France from Spain, and the Dofrafeld, which divide Norway from Sweden. The most elevated ridges in Asia are Mount Taurus, Imaus, Caucasus, Ararat, the Uralian, the Altaian, and the Mountains of Japan, —in Africa, Mount Atlas, and the Mountains of the Moon. Some of the mountains in these ranges are found to contain immense caverns or perforations, of more than two miles in circumference, reaching from their summits to an immeasurable depth in the bowels of the earth. From these dreadful openings are frequently thrown up, to an immense height, torrents of fire and smoke, rivers of melted metals, clouds of ashes and cinders, and sometimes red-hot stones and enormous rocks, to the distance of several miles, accompanied with thunders, lightnings, darkness, and horrid subterraneous sounds—producing the most terrible devastations through all the surrounding districts. The most noted mountains of this kind in Europe are mount Hecla, in Iceland; Etna, in Sicily; and Vesuvius, near the city of Naples, in Italy. Numbers of volcanoes are also to be found in South America, in Africa, in the islands of the Indian ocean, and in the empire of Japan.\*

We who live in Great Britain where the highest mountain is little more than three quarters of a mile in perpendicular elevation, can form no adequate idea of the magnificence and awful sublimity of the mountain scenery in some of the countries now mentioned, especially when the volcano is belching forth its flames with a raging noise, and spreading terror and desolation around its base. From the tops of the lofty ridges of the Andes, the most grand and novel scenes sometimes burst upon the eye of the astonished traveler. He beholds the upper surface of the clouds far below him covering the subjacent plain, and surrounding, like a vast sea, the foot of the mountain; while the place on which he stands appears like an island in the midst of the ocean. He sees the lightnings issuing from the clouds, and hears the noise of the tempest and the thunders rolling far beneath his feet, while all is serene around him, and the blue vault of heaven appears without a cloud. At other times he contemplates the most sublime and extensive prospects—mountains ranged around him, covered with eternal snows, and surrounding, like a vast amphitheater, the plains below—rivers winding from their sources toward the ocean—cataracts dashing headlong over tremendous cliffs—enormous rocks detached from their bases, and rolling down the declivity of the mountains with a noise louder than thunder—frightful precipices impeding over his head—unfathomable caverns yawning from below—and the distant volcano sending forth its bellowings, with its top enveloped in fire and smoke. Those who have studied nature on a grand scale have always been struck with admiration and astonishment at the sublime and awful exhibition of wonders which mountainous regions exhibit; and perhaps there is no *terrestrial* scene which presents, at one view, so many objects of over-

powering magnitude and grandeur, and which inspires the mind with so impressive an idea of the power of that Almighty Being, who “weigheth the mountains in scales, and taketh up the isles as a very little thing.”

THE OCEAN.—The ocean surrounds the earth on all sides, and penetrates into the interior parts of different countries, sometimes by large openings, and frequently by small straits. Could the eye take in this immense sheet of waters at one view, it would appear the most august object under the whole heavens. It occupies a space on the surface of the globe at least three times greater than that which is occupied by the land; comprehending an extent of 148 millions of square miles. Though the ocean, strictly speaking, is but *one* immense body of waters, extending in different directions, yet different names have been appropriated to different portions of its surface. That portion of its waters which rolls between the western coast of America, and the eastern shores of Asia, is called the *Pacific* ocean; and that portion which separates Europe and Africa from America, the *Atlantic* ocean. Other portions are termed the *Northern*, *Southern*, and *Indian* oceans. When its waters penetrate into the land, they form what are called gulfs, and mediterranean seas. But without following it through all its windings and divisions, I shall simply state a few general facts.

With regard to the DEPTH of this body of water, no certain conclusions have yet been formed. Beyond a certain depth, it has hitherto been found unfathomable. We know, in general, that the depth of the sea increases gradually as we leave the shore; but we have reason to believe that this increase of depth continues only to a certain distance. The numerous islands scattered everywhere through the ocean, demonstrate, that the bottom of the waters, so far from uniformly sinking, sometimes rises into lofty mountains. It is highly probable, that the depth of the sea is somewhat in proportion to the elevation of the land; for there is some reason to conclude, that the present bed of the ocean formed the inhabited part of the ancient world, previous to the general Deluge, and that we are now occupying the bed of the former ocean; and if so, its greatest depth will not exceed four or five miles; for there is no mountain that rises higher above the level of the sea. But the sea has never been actually sounded to a greater depth than a mile and 66 feet. Along the coast its depth has always been found proportioned to the height of the shore; where the coast is high and mountainous, the sea that washes it is deep; but where the coast is low, the water is shallow. To calculate the *quantity* of water it contains, we must therefore suppose a medium depth. If we reckon its average depth at two miles, it will contain 296 millions of cubical miles of water. We shall have a more specific idea of this enormous mass of water, if we consider, that it is sufficient to cover the whole globe, to the height of more than eight thousand feet; and if this water were reduced to one spherical mass, it would form a globe of more than 800 miles in diameter.

With regard to its BOTTOM—As the sea covers so great a portion of the globe, we should, no doubt, by exploring its interior recesses, discover a vast number of interesting objects. So far as the bed of the ocean has been explored, it is found to bear a great resemblance to the surface of the dry land; being, like it, full of plains, caverns, rocks, and mountains, some of which are abrupt and almost perpendicular, while others rise with

\* A more particular description of the phenomena of these terrific objects will be found in chap. iv, sect. 2.

a gentle acclivity, and sometimes tower above the water, and form islands. The materials, too, which compose the bottom of the sea are the same which form the bases of the dry land. It also resembles the land in another remarkable particular;—many fresh springs, and even rivers, rise out of it; an instance of which occurs near Goa, on the western coast of Hindostan, and in the Mediterranean sea, not far from Marseilles. The sea sometimes assumes *different colors*. The materials which compose its bottom cause it to reflect different hues in different places; and its appearance is also affected by the winds and by the sun, while the clouds that pass over it communicate all their varied and fleeting colors. When the sun shines, it is green; when he gleams through a fog, it is yellow; near the poles, it is black; while in the torrid zone, its color is often brown; and, on certain occasions, it assumes a luminous appearance, as if sparkling with fire.

The ocean has *three kinds of motions*. The first is that undulation which is produced by the wind, and which is entirely confined to its surface. It has been ascertained that this motion can be destroyed, and its surface rendered smooth, by throwing oil upon its waves. The second motion is that continual tendency which the whole water in the sea has toward the west, which is greater near the equator than toward the poles. It begins on the west side of America, where it is moderate; but as the waters advance westward, their motion is accelerated; and, after having traversed the globe, they return, and strike with great violence on the *eastern* shore of South America. Being stopped by that continent, they rush, with impetuosity, into the Gulf of Mexico, thence they proceed along the coast of North America, until they come to the south side of the great bank of Newfoundland, when they turn off and run down through the Western Isles. This motion is most probably owing to the diurnal revolution of the earth on its axis, which is in a direction contrary to the motion of the sea. The third motion of the sea is the *tide*, which is a regular swell of the ocean every 12½ hours. This motion is now ascertained to be owing to the attractive influence of the moon, and also partly to that of the sun. There is always a flux and reflux at the same time, in two parts of the globe, and these are opposite to each other; so that when our Antipodes have high water, we have the same. When the attractive powers, of the sun and moon act in the same direction, which happens at the time of new and full moon, we have the highest, or *spring tides*; but when their attraction is opposed to each other, which happens at the quarters, we have the lowest, or *neap tides*.

Such is the ocean, a most stupendous scene of Omnipotence, which forms the most magnificent feature of the globe we inhabit. When we stand on the sea-shore, and cast our eyes over the expanse of its waters, until the sky and the waves seem to mingle, all that the eye can take in at *one* survey is but an inconsiderable *speck*, less than the hundred-thousandth part of the whole of this vast abyss. If every drop of water can be divided into 26 millions of distinct parts, as some philosophers have demonstrated,\* what an immense assemblage of watery particles must be contained in the unfathomable caverns of the ocean! Here the powers of calculation are completely set at defiance; and an image of infinity, immensity, and endless duration, is presented to the mind. This mighty

expanse of waters is the grand reservoir of Nature, and the source of evaporation, which enriches the earth with fertility and verdure. Every cloud which floats in the atmosphere, and every fountain, and rivulet, and flowing stream, are indebted to this inexhaustible source for those watery treasures which they distribute through every region of the land. In fine, whether we consider the ocean as rearing its tremendous billows in the midst of the tempest, or as stretched out into a smooth expanse—whether we consider its immeasurable extent, its mighty movements, or the innumerable beings which glide through its rolling waves—we cannot but be struck with astonishment at the grandeur of that Omnipotent Being who holds its waters in the “hollow of his hand,” and who has said to its foaming surges, “Hitherto shalt thou come, and no farther; and here shall thy proud waves be stayed.”

RIVERS.—The next feature of the earth's surface which may be noticed, is the rivers with which it is indented in every direction. These are exceedingly numerous, and seem to form as essential a part in the constitution of our globe, as the mountains from which they flow, and as the ocean to which they direct their course. It is reckoned, that in the old continent, there are only about 430 rivers, which fall directly into the ocean, or into the Mediterranean and the Black seas; but in the new continent, there are only about 145 rivers known, which fall directly into the sea. In this enumeration, however, only the great rivers are included, such as the Thames, the Danube, the Wolga, and the Rhone. Beside these, there are many thousands of streams of smaller dimensions, which, rising from the mountains, wind in every direction, until they fall into the large rivers, or are carried into the ocean. The largest rivers in Europe are—the Wolga, which, rising in the northern parts of Russia, runs a course of 1700 miles, until it falls into the Caspian sea—the Danube, whose course is 1300 miles, from the mountains in Switzerland to the Black sea—and the Don, which runs a course of 1200 miles. The greatest rivers in Asia are—the Houho, in China, whose course is 2400 miles—the Boorhampootee, the Euphrates, and the Ganges. The longest river in Africa is the Nile, the course of which is estimated at 2000 miles. In the continent of America, the rivers appear to be formed on the grandest scale, both as to the length of their course, and the vast body of waters which they pour into the ocean. The Amazon, the largest river in the world, runs a course of above 5000 miles across the continent of South America, until it falls into the Atlantic ocean, where it discharges a body of waters 150 miles in breadth. Next to this is the river St. Lawrence, which is more than 2400 miles from its mouth through the lake of Ontario to the lake Alempigo and the Assiniboins; and the rivers La Plata and Mississippi, each of whose courses is not less than 2000 miles.

When we consider the number and the magnitude of these majestic streams, it is evident, that an enormous mass of water is continually pouring into the ocean from every direction. From observations which have been made on the river Po, which runs through Lombardy, and waters a tract of land 380 miles long and 120 broad, it is found, that it moves at the rate of four miles an hour, is 1000 feet broad and 10 feet in depth, and consequently, supplies the sea with 5068 millions of cubical feet of water in a day, or a cubical mile in 29 days. On the supposition that the quantity of water which the sea receives from the great rivers in all countries, is proportional to the

\* The demonstration of this proposition may be seen in Nieuwenhuyt's Religious Philosopher, vol. iii, p. 652.



extent and surface of these countries, it will follow, that the quantity of waters carried to the sea by all the other rivers on the globe, is 1083 times greater than that furnished by the Po (supposing the land, as formerly stated, to contain about 49 millions of square miles), and will supply the ocean with 13,630 cubical miles of water in a year. Now reckoning the ocean, as formerly, to contain 296 millions of cubical miles of water, this last number divided by the former, will give a quotient of 21,716. Hence it appears, that, were the ocean completely drained of its waters, it would require more than *twenty thousand years*\* before its caverns could be again completely filled by all the rivers in the world running into it, at their present rate.

Here two questions will naturally occur—Whence do the rivers receive so constant a supply of water? and, Why has not the ocean long ago overflowed the world, since so prodigious a mass of water is continually flowing into its abyss? This was a difficulty which long puzzled philosophers; but it is now satisfactorily solved, from a consideration of the effects of evaporation. By the heat of the sun, the particles of water are drawn up into the atmosphere, from the surface of the ocean, and float in the air in the form of clouds, or vapor. These vapors are carried, by the winds, over the surface of the land, and are again condensed into water on the tops and the sides of the mountains, which, gliding down into their crevices and caverns, at length break out into springs, a number of which meeting in one common valley, become a river; and many of these united together, at length form such streams as the Tay, the Thames, the Danube, and the Rhine. That evaporation is sufficient to account for this effect, has been demonstrated by many experiments and calculations. It is found, that from the surface of the Mediterranean sea, which contains 762,000 square miles, there are drawn up into the air every day, by evaporation, 5280 millions of tons of water, while the rivers which flow into it yield only 1827 millions of tons in the same time; so that there is raised in vapor from the Mediterranean nearly *three times* the quantity of water which is poured into it by all its rivers. One third of this falls into the sea before it reaches the land; another part falls on the low lands, for the nourishment of plants; and the other third part is quite sufficient to supply the sources of all the rivers which run into the sea. This is in full conformity to what was long ago stated by an inspired Naturalist; “All the rivers run into the sea, and yet the sea is not full; unto the place from whence the rivers come, thither do they return again;” but, before they regain their former place they make a circuit over our heads through the regions of the atmosphere.

Such are the varied movements and transformations which are incessantly going on in the rivers, the ocean, and the atmosphere, in order to preserve the balance of nature, and to supply the necessities of the animal and vegetable tribes; all under the agency and direction of Him who “formed the sea and the dry land,” and who has arranged all things in number, weight, and measure, to subserve the purposes of his will.

Rivers serve many important purposes in the

\* Buffon makes this result to be 812 years, in which he is followed by Goldsmith, and more subsequent writers; but he proceeds on the false assumption, that the ocean covers only half the surface of the globe, and that it contains only 55 millions of square miles, and he estimates the average depth of the ocean to be only 150 yards, or one-fourth of a mile.

economy of our globe. They carry off the redundant waters which fall in rains, or which ooze from the springs, which might otherwise settle into stagnant pools; they supply to the seas the loss of waters occasioned by their daily evaporation; they cool the air, and give it a gentle circulation; they fertilize the countries through which they flow; their waters afford a wholesome drink, and the fishes they contain a delicious food for the nourishment of man; they facilitate commerce, by conveying the productions of nature and art from the inland countries to the sea; they form mechanical powers for driving machinery of different kinds; they enliven and diversify the scenery of the countries through which they pass; and the cataracts which they frequently form among the mountains, present us with scenes the most picturesque and sublime; so that every part of the constitution of nature is rendered subservient both to utility and to pleasure.

Waving the consideration of other particulars, I shall simply state some of the artificial divisions of the earth, and two or three facts respecting its inhabitants.

The LAND has generally been divided into four parts, Europe, Asia, Africa, and America, to which has been lately added the division called Australasia, which comprehends, New Holland, New Guinea, New Zealand, Van Dieman's Land, and several other islands in the Pacific ocean.

Europe comprehends the following countries—Norway, Sweden, Denmark, Russia, Prussia, Germany, Austria, Turkey, Italy, Switzerland, France, Holland, Belgium, or the Netherlands, Spain, Portugal, and Great Britain and Ireland, together with the islands of Sicily, Malta, Candia, Corsica, Sardinia, Majorca, Minorca, Ivica, Zealand, Funen, Gothland, Iceland, and several others of smaller note.

Europe is the smallest of the five grand divisions of the globe. Its greatest extent is from northeast to southwest, namely, from the mouth of the Kara in N. Lat. 65° 40' to the rock of Lisbon in N. Lat. 35° 45', which is computed at 3400 British miles. Its greatest breadth, from Cape Matapan, in the Morea, to the North Cape of Norway, is computed at 2350 miles. Its superficial contents have been computed at 3,650,000 square miles, or 2,336,000,000 English acres, reckoning 640 to the square mile. Its form is singularly broken and varied, being split into many distinct portions, peninsulas, and large islands with extended and winding coasts, which arises chiefly from the number of its inland seas, of which the Mediterranean, the Baltic, and the Black sea, are the most important. Its rivers are numerous, the largest of which are the Rhine, the Rhone, the Wolga, and the Danube. Its mountains do not reach that stupendous height, nor extend in such unbroken chains, as those of Asia and America. Its highest ranges are the Alps and Pyrenees, the Appennines in Italy, and the Dofrafield, in Norway. Its lakes, though numerous, are comparatively small; those of Ladoga and Onega alone being of any commercial importance. Its soil is distinguished for its valuable productions: Grain of different kinds is raised over its whole surface, except in the extreme north—wines throughout all its southern region; and it is equally productive in hemp, flax, wool, and silk. Its northern forests produce some of the finest timber in the world; and the iron of Europe surpasses that of any other country. The cultivation of the soil is carried on with great diligence, and in point of science, skill, and the

extent of capital employed upon it, and upon every branch of commerce and manufacture, it stands unrivaled among the other countries of the globe. Its commerce is on a very extensive scale, and in manufacturing skill it has surpassed every other country, both in the variety and the cheapness of its productions. European vessels, conveying articles and manufactures of all descriptions, are to be found at the utmost bounds of Asia and America, in the snowy regions of the poles, and crowding the ports of New Holland, Van Dieman's Land, New Zealand, and the islands of the Indian and Pacific oceans.

The population of Europe is now reckoned to amount to about 200 millions. Its inhabitants are divided chiefly into three races, the Slavonic, Teutonic, and Romish races. The *Slavonic* consists of about 25 millions of Russians, 10 millions of Poles, and 10 millions in other adjacent countries. The *Teutonic* race, which occupy the greater part of Scandinavia, the Netherlands, and Great Britain, may be estimated at 50 millions. The *Romish* race includes the inhabitants of Southern Europe, France, Italy, Spain, etc., and may be estimated at about 80 millions. The Celts in Scotland, Ireland, Wales, and Spain, are the remains of the most ancient inhabitants of Western Europe, and may amount to 6 millions. The Greeks in Europe amount to 2 millions, and the Jews throughout all Europe to about 2 millions. The Tartars, Turks, Hungarians, and Gypsies, which are of Asiatic origin, amount altogether to 6 or 7 millions. Though this division of the earth is least in point of size—being only the one sixteenth part of the terraqueous globe—it is yet by far the greatest as to moral, political, and commercial importance. Its surface is in general more crowded with inhabitants than most other countries (China excepted), more improved by cultivation, more enriched by industry and commerce—embellished with mighty cities, and splendid works of art, and illuminated with the reflections of genius. Here we behold mind asserting its supremacy over matter, and man, the lord of this lower world, pursuing the high destiny originally assigned him “to replenish the earth and subdue it.” In learning, arts, and sciences, Europe has far surpassed every other portion of the globe; and by the invention of Printing, knowledge of every description is now rapidly diffused, and promoting the moral and intellectual improvement of its population.

*Asia*, the largest and most populous division of the ancient continent, contains the empires of China and Japan, Chinese Tartary, Thibet, Hindostan, or British India, the Birman Empire, Persia, Arabia, Turkey in Asia, Siberia, Independent Tartary, and a variety of territories inhabited by tribes with which we are very imperfectly acquainted; together with the immense islands of Borneo, Sumatra, Java, Ceylon, Segalien, the Philippines, and thousands of others of smaller dimensions. The immense expanse of Asia presents every possible variety of soil and climate, as it extends from the confines of the polar regions to the tropical climes. Its grandest feature is a chain of mountains crossing it from the Mediterranean to the Eastern seas, of which Taurus, Caucasus, and the Himalaya are the portions best known. One leading feature of middle Asia consists in large lakes or inland seas, salt like the ocean, and having no outlets; of which the Caspian, the Sea of Aral, and Baikal, are the largest. It contains many rivers of great magnitude. The Euphrates, the Ganges, the Hoanho, and the Amur, in the length of their course, yield only to

the rivers of the New world. This quarter of the globe is reckoned to be 7500 miles in length, from east to west, and about 5000 miles in breadth, from south to north, and contains about 16 millions of square miles, being more than four times larger than Europe. Its inhabitants have been computed by some writers to amount to 580 millions. It was in Asia where the human race was first planted; it became the nursery of the world after the universal deluge, and it was the scene in which the most memorable transactions recorded in the sacred history took place. But its inhabitants are now immersed in Mahometan and Pagan darkness; and the Christian Religion, except in a few insulated spots, is almost unknown among its vast population. It is the richest and most fruitful part of the world, and produces cotton, silks, spices, tea, coffee, gold, silver, pearls, diamonds, and precious stones: but despotism, in its worst forms, reigns, uncontrolled over every part of this immense region.

*Africa* comprehends the following kingdoms—Morocco, Algiers, Tunis, Tripoli, Egypt, Zaara, N-groland, Guinea, Nubia, Abyssinia, Caffraria, Dahomey, Benin, Congo, Angola, and various other territories. By far the greater part of Africa remains hitherto unexplored, and, consequently, we are possessed of a very slender portion of information respecting the numerous tribes that may inhabit it. This quarter of the world, which once contained several flourishing kingdoms and states, is now reduced to a general state of barbarism. That most abominable traffic, the slave trade, is carried on to an unlimited extent on its western coasts, by a set of European ruffians, whose villanies are a disgrace to human nature. It is to be hoped, this traffic will, ere long, be extirpated by the efforts now making by European nations, and by the plans which are now concerting for promoting the religious, moral, and commercial improvement of this country. The Christian Religion has lately been introduced into its southern regions, in the districts adjacent to the Cape of Good Hope, and the labors of Missionaries of different denominations appear, in numerous instances, to have been crowned with remarkable success.\*—A colony of blacks, formerly slaves in America, has lately been established on the western coast, a little to the south of Sierra Leone, which goes by the name of *Liberia*. All the affairs of this little state are conducted by emancipated negroes, and particular attention is paid to the literary and religious instruction of the colonists. Some of the Newspapers we have seen, published by the settlers in this colony, indicate a considerable degree of talent and information; and there is a prospect that the improvements going forward in Liberia will, ere long, produce a beneficial influence on those tribes who occupy the adjacent territories, and have a tendency to lessen the traffic in slaves. The greatest breadth of Africa is about 4790 miles, and its length from north to south about 5000 miles. Its most striking features are those immense deserts, near its northern parts, which comprise nearly one-third of its surface. The deserts of Zaara are 1500 miles long and eight hundred broad.

*America* is divided into North and South. It remained unknown to the inhabitants of the Eastern hemisphere until the year 1492, when it was discovered by Columbus, who first landed on Guanahani, or *Cat Island*, one of the Bahama isles. North America comprehends the following

\* See Moffat's interesting work, entitled “Missionary Scenes and Labors in Southern Africa.” 1842.

countries: The United States, New and Old Mexico, Upper and Lower Canada, Nova Scotia, New Brunswick, and Labrador. South America comprehends the immense districts called Terra Firma, Peru, Guiana, Amazonia, Paraguay, Brazil, Chili, and Patagonia.—Between N. and S. America, lie the islands of Cuba, St. Domingo, Jamaica, and Porto Rico, known by the name of the *West Indies*. America is bounded on the east by the Atlantic, on the west by the Pacific, and on the north by the Arctic ocean. South America comprises a surface of six and a half millions of square miles, its length being 4500 miles, and its greatest breadth 3200 miles. North America, exclusive of the islands that surround it, contains about nine millions of square miles. It has been divided into five physical regions: 1. The table land of Mexico; 2. The slope lying between the rocky mountains and the Pacific ocean; 3. The great valley of the Mississippi; 4. The eastern declivity of the Alleghany mountains; 5. The great northern plain beyond 50° north latitude, a bleak and barren waste, covered with lakes. Beside these, there are connected with America, the Bahama and Caribbee islands, Newfoundland, Cape Breton, Tobago, Trinidad, Terra del Fuogo, &c. America is distinguished by its numerous and extensive lakes, which resemble large inland seas. Its rivers, also, form one of its grand and distinguishing features, being the largest on the globe. It is likewise diversified with lofty and extensive ranges of mountains. When first discovered, it was almost wholly covered with immense forests and thinly peopled with a number of savage tribes. Its mingled population of Aborigines and Europeans is now making rapid advances in knowledge, civilization, and commerce.

The *United States*, which extend from the 20th to the 50th degree of north latitude, form the greatest and most influential power that exists on this continent, and possess a territory of vast extent—stretching from the great lakes to the Gulf of Mexico, a breadth of about 1600 miles; and from the Atlantic to the Pacific ocean, a length of 2500 miles, including a surface of 2,500,000 square miles. The population of these States now amounts to about 15 millions—an astonishing number, when we consider that only a little more than 200 years ago these territories were little else than a boundless wilderness, peopled by a few tribes of savages. Were they brought to a cultivated state, they would be sufficient to subsist a population of three or four hundred millions. These States have been peopled from different European nations, particularly from Great Britain and Ireland, and the English language prevails over most of the 26 States. The form of government is that of a republic; and in religion they have adopted the system of cutting off all connection between church and state. Every sectary chooses its own pastor and provides entirely for his support. Literature and science have not yet reached the high elevation they have attained in Europe; but numerous colleges, highly respectable, and literary institutions of various descriptions, have been established,—some of which enjoy a high reputation. The education of the mass of the community forms a prominent object of attention in each state; and the benefits of a good common education are perhaps more generally diffused than in any other country in the world. It is much to be regretted that the system of slavery still prevails in the *Southern* states, notwithstanding all the remonstrances which have been made against it by the inhabi-

tants of the Northern states, and by other nations. But it is to be hoped that the good sense of the inhabitants of these states will, ere long, excite them to arouse themselves to remove that blot upon their national character by which their institutions have been so long and so deeply disgraced.

**AUSTRALASIA** is the name given to a number of large islands occupying a portion of the Indian or Southern Pacific ocean, between the 10th and 45th degrees of south latitude. The chief island in the group is New Holland or *Australia*, the largest island in the world, being about 2400 miles in length, from east to west, and 1800 from north to south, comprising an area of nearly three millions of square miles. The country is generally flat, with the exception of some mountain ranges, and in many places the *inclination* is inward, instead of outward toward the sea, so that the mountains and elevated land form a ridge nearly round it. The great Kangaroo is the largest quadruped in this country, and the total absence of such animals as lions, tigers, deer, oxen, horses, bears, is the most striking feature in this region. The native human beings are of the Malay race, and exist in the lowest state of degradation and barbarism.—Three British settlements have been formed in New Holland: 1. *New South Wales*, which stretches about 1400 miles along its eastern coast, and some hundreds of miles inland.—This is the oldest and most populous of the Australian colonies, and was selected at first for the transportation of convicts, though voluntary emigrants, of late years, have emigrated thither in considerable numbers. It lies at the distance of about 16,000 miles from Great Britain; but the voyage to it is generally accomplished in from 100 to 120 days. Its capital, *Sydney*, pleasantly situated on a fine bay, called Port Jackson, is now considered as containing a population of 25,000. The whole population of this colony, free and convict, is calculated to be about 110,000, and it is rapidly increasing. 2. *Western Australia*, or the *Swan-river settlement*, which is not so populous, nor does it appear so prosperous as the other settlements. 3. *South Australia*—which lies on the southern shore. In this colony slavery is not permitted to exist, nor are any convicts allowed to be sent to it from England. Here learning and religion are greatly encouraged, and every mean has been employed by the directors of the South Australian Company to render the settlers, as far as possible, a moral and religious population. The capital is *Adelaide*, which already contains about 7000 inhabitants, although it is only about five years since the colony was established. Each denomination of Christians supports its own ministers and places of worship; and already about £15,000 have been expended in Adelaide and its vicinity in erecting chapels for Christian worship. Three millions of capital have been invested in this province up to the 1st December, 1841, and 431,984 acres of land have been surveyed. The climate is one of the finest and most salubrious in the world, and it has sometimes been alluded to as “the fair and fertile province of South Australia.” Its winter, which is mild, is in May, June, and July; and its summer in November, December, and January.

*Van Dieman's Land* is an island of about the size of England, which is separated from New Holland by a channel 90 miles wide, called Bass's Strait. Its shape is nearly that of a parallelogram. It is more hilly and better watered than Australia, and possesses many excellent harbors. Its capital is Hobart-Town, situated on the south-

ern side of the island, and on the northern shore is Launcetown, the second town, and a busy seat of trade. The population of the island was lately estimated at 25,000, of which about one half were convicts.

*New Zealand* consists chiefly of two large islands, called the Middle Island, and the North Island, separated by a passage called Cook's Straits, with numerous smaller isles scattered around their shores. They lie in an easterly direction from New Holland, at a distance of about 1200 miles from that continent, between the 34th and 48th degrees of south latitude, and the 166th and 179th of east longitude. The southern island is about 500 miles long, and nearly 120 broad. The northern is about 400 miles long, and from 5 to 30 broad. Both the islands are estimated to contain 95,000 square miles, of which two-thirds are fit for cultivation. Numbers of fine streams and rivers are scattered through the country, and the bays and harbors are not surpassed either in number or advantages by those of any country in the world. A chain of mountains runs through the whole of the southern and a considerable part of the northern island, some of the tops of which are as high as 14,000 feet above the level of the sea, and present a highly picturesque appearance. All accounts agree that the climate is highly salubrious, and very congenial to European constitutions. The natives of this country were formerly savage and dangerous, but are now partially improved and comparatively harmless in disposition, the missionaries having now acquired a considerable influence over certain tribes. It is universally admitted that they are a robust and healthy looking people; and Captain Cook observes that he never saw a single person among them who appeared to have any bodily complaint, and that their wounds healed with astonishing rapidity. The entire population of this country has been estimated at 15,000, which is at the rate of 5 persons to 3 square miles. The *New Zealand Company* for colonizing this country was established in May, 1839, and is now employed in carrying its plans into effect. Land has been purchased from the natives, and a considerable number of adventurers have already taken possession of certain districts. A township has been marked out on the shores of Port Nicholson—a fine harbor in the Northern Island about the center of Cook's straits—to be named Wellington, which it is supposed will be the capital of the colony. But apprehensions are entertained that misunderstandings and serious disputes may arise between the settlers and the natives, and that the runaway convicts from Botany Bay, and the southern whalers, will introduce dissension and immorality among the colonists.

*New Guinea*, next to New Holland, is the largest island of Australasia, being 1100 miles long. It is inhabited by Papuans, with the still ruder race of Haraforas in the interior. This island is said to be one of the finest countries in existence, producing most of the rich fruits of the torrid zone, such as cocoas, nutmegs, cloves, and spices of all kinds, and is everywhere covered with lofty forests. The Papuans are much farther advanced in civilization than the New Hollanders; but no European nation has yet attempted a settlement in this island.—*New Britain*, *New Ireland*, and several others, compose a group inhabited by Papuans. The Archipelago, called the *Solomon's islands*, is inhabited by Papuans, with a mixture of Malays.

*Polynesia*, or "the many isles," includes the numerous group of islands with which a consider-

able portion of the Pacific ocean is diversified. They principally lie in an easterly and north-easterly direction from Australasia, within about 30 degrees on both sides of the equator. They are many thousands in number, and are inhabited by savage races, who have generally been found more tractable than the barbarous tribes of other parts of the world. They may be divided into the great groups of the *Society*, *Sandwich*, *Marquesas*, *Friendly*, *Navigators*, *Caroline*, and *Martianne islands*, with several others. Most of these islands are fruitful and beautiful; some are exceedingly high and romantic, and their climate is reckoned the most delicious on the globe. The *Society islands*, though not the largest, are the most beautiful, and those in which civilization and polished manners have made the greatest progress. Tahiti, the largest in the group, is one of the brightest gems of the Pacific, as the people of this island were the first to abjure Paganism and to embrace Christianity. It consists of two peninsulas, joined by a narrow isthmus. The one is about 25 miles long and about the same in breadth. The other is about 20 miles in length by 15 in breadth. The religion of the natives, like that of the Tonga, Sandwich, and other islanders, was, until within these 20 or 30 years, idolatry of the most barbarous kind, their manners were extremely licentious, and their dispositions sometimes ferocious and cruel. They were perpetually at war among themselves, and their contests were of the most relentless and cruel character. But, in consequence of the labors of Christian Missionaries, sent out by the London Missionary Society, the majority of the inhabitants of this and the adjacent islands have made an open profession of Christianity. Their places of idolatrous worship have been thrown down, their idol gods destroyed, and an end put to their ferocious and destructive wars. The whole of the Sacred Scriptures has been translated into their native language; they are learning to read the word of God; and, in numerous instances, they have made a wonderful progress in studying its facts and doctrines, and in practicing those duties which it enjoins. The consequence has been that they have made a great improvement in all the arts and accommodations of life. They have built ships, engaged in manufactures of different kinds, reared spacious places of worship, established schools and other seminaries of instruction, erected villages adorned with neat and commodious habitations, and have made astonishing progress in the cultivation of the soil. The moral transformation and improvements which have been effected among the inhabitants of these islands in consequence of the introduction of Christianity—afford a striking and incontestable proof, that there are no tribes on the face of the earth, however barbarous and debased, but may be raised to the dignity of their moral and intellectual natures, were the religion of the Bible once introduced among them, and every other judicious mean employed to promote their progress in knowledge and civilization.

The *Sandwich Islands* lie about 20 degrees north of the equator, and about 2500 miles north by west of Tahiti. *Ocheye*, the largest of the group, is remarkable for the murder of the celebrated Capt. Cook in 1779. It measures 84 miles in length, by 70 in breadth. It abounds with lofty mountains. Mount Roa rises to the height of 16,000 feet, and Mount Koa to the height of 13,000 feet, the tops of both being covered with perpetual snow. It also abounds with volcanoes. The volcano of Peli, on the flank of Mount Roa,

is reckoned one of the most striking and awful in any part of the world. The people of the Sandwich islands have, of late years, embraced Christianity, and several missionaries from the United States are now settled in those regions. A considerable part of the population, including the king and his court, attend the schools they have established, and the ordinances of Christian worship. They have formed a small navy, and carry on a profitable trade with foreigners, and the general state of morals is undergoing a great improvement.

The *Friendly Islands* include the Fejee, and several other detached islands, of which Tongataboo is the largest. They enjoy a remarkably rich soil, which is carefully cultivated by the natives, who rank among the most respectable of the South-Sea islanders, and are remarkable for their neatness and skill in improving and inclosing their lands. Christianity has been lately introduced into some of these islands, chiefly by the persevering labors of the Wesleyan Missionaries.

Their population is reckoned at about 100,000.—The *Navigators' Islands* are among the most important and fertile group yet discovered in Southern Polynesia. The natives are uncommonly tall and stout, and remarkable for a ferocity of character scarcely found in any other part of Polynesia. Here, however, the Christian religion has lately been introduced, and is already producing many interesting and beneficent effects.—The *Marquesas* are situated north by east from the Society Isles, within 9° of the Equator. Their inhabitants are distinguished for their fair complexion and peculiar beauty, but they are fierce and licentious in their character. Christianity has been introduced, but has hitherto produced little effect upon them.—The *New Hebrides* are a group generally covered with high mountains, some of which contain volcanoes. They are situated about five or six hundred miles west of the Friendly Isles, and were first discovered by Quiros in 1636, when they were supposed to be part of a great southern continent which philosophers then imagined to exist. But Cook, in 1774, explored the whole group, and gave them the name of the New Hebrides. The cluster consists of about 17 islands, of which *Terra del Espirita Santo* is the largest. At *Erromango*, one of these islands, the deeply lamented missionary WILLIAMS was treacherously and cruelly murdered by the natives, along with another missionary of the name of HARRIS, in 1839, when attempting to introduce Christianity among them. This island will be as much distinguished in future ages for this atrocious murder as the island of Owhyhee has been for the murder of Captain Cook. The geographical discoveries of this celebrated circumnavigator prepared the way for most of the missionary operations which have been undertaken in the islands of the Pacific, and of all the laborers in this work of philanthropy, none stands so conspicuous, for unwearied beneficent exertions in this holy cause, and for the important and beneficial effects with which they have been accompanied as the lamented WILLIAMS. His "Narrative of Missionary Enterprises in the South-Sea Islands," deserves to be read by every Christian, by every philosopher and statesman, and by every one who feels a delight in contemplating beneficent actions and romantic incidents.

In regard to the *human inhabitants* that occupy the different regions now specified—they have been divided by some geographers into the six following classes:—1. The dwarfish inhabitants of the polar regions; as the Laplanders, the Green-

landers, and the Esquimaux. 2. The flat-nosed, olive-colored tawny race; as the Tartars, the Chinese, and the Japanese. 3. The blacks of Asia with European features. Of this description are the Hindoos, the Birmanis, and the inhabitants of the islands of the Indian ocean. 4. The woolly-haired negroes of Africa, distinguished by their black color, their flat noses, and their thick lips. 5. The copper-colored native Americans, distinguished likewise by their black hair, small black eyes, high cheek bones, and flat noses. 6. The sixth variety is the white European nations, as the British, the French, the Italians, and the Germans.

The number of inhabitants which people the earth at one time, may be estimated to amount to at least *eight hundred millions*; of which 500 millions may be assigned to Asia; 58 millions to Africa; 42 millions to America; and 200 millions to Europe.—With regard to their religion, they may be estimated as follows:—

Pagans,.....	490,000,000
Romanetans,.....	100,000,000
Roman Catholics,.....	100,000,000
Protestants,.....	55,000,000
Greeks and Arminians,....	50,000,000
Jews,.....	5,000,000
	800,000,000

From this estimate it appears that there are nearly 3 Pagans and Mahometans to 1 Christian, and only 1 Protestant to about 14 of all the other denominations. Although all the Roman Catholics, Greeks, and Protestants, were reckoned true Christians, there still remain more than 595 millions of our fellow-men ignorant of the true God, and of his will as revealed in the sacred Scriptures; which shows that a vast field of exertion still lies open to Christian benevolence, before the blessings of civilization, mental improvement, rational liberty, and Christianity, be fully communicated to the Pagan and Mahometan world.

If we suppose that the earth, at an average, has always been as populous as it is now, and that it contains 800 millions of inhabitants, as above stated, and if we reckon 32 years for a generation, at the end of which period the whole human race is renewed; it will follow, that one hundred and forty-six thousand two hundred millions of human beings have existed on the earth since the present system of our globe commenced, reckoning 5-6 years from Adam to the present time.\* And consequently, if mankind had never died, there would have been nearly 183 times the present number of the earth's inhabitants now in existence. It follows from this statement, that 25 millions of mankind die every year, 2853 every hour, and 47 every minute, and that at least an equal number, during these periods, are emerging from non-existence to the stage of life; so that almost every moment a rational and immortal being is ushered into the world, and another is transported to the invisible state. Whether,

\* This calculation proceeds on the supposition, that on y 4004 years elapsed between the creation of man and the birth of Christ, according to the Hebrew Chronology. But Dr. Hales, in his late work on Scripture Chronology, has proved almost to a demonstration, that from the Creation to the birth of Christ, are to be reckoned 5411 years; and this computation nearly agrees with the Samaritan and Septuagint Chronology, and with that of Josephus. According to this computation, 7253 years are to be reckoned from the Creation to the present time; and consequently, 220 thousand 500 millions of human beings will have existed since the Creation, which is more than 225 times the number of inhabitants presently existing.

therefore, we contemplate the world of matter, or the world of mind, we perceive incessant changes and revolutions going on, which are gradually carrying forward the earth and its inhabitants to some important consummation.—If we suppose that before the close of time, as many human beings will be brought into existence, as have already existed during the bypast ages of the world, there will, of course, be found at the general resurrection 232,400,803,999 of mankind. Vast as such an assemblage would be, the whole of the human beings here supposed, allowing six square feet for every individual, could be assembled within the space of about 62,400 square miles, or on a tract of land not much larger than that of England, which contains, according to the most accurate calculation, above 50,000 square miles.

Our world is capable of sustaining a much greater number of inhabitants than has ever yet existed upon it at any one time. And since we are informed in the Sacred oracles that God "created it not in vain, but *formed it to be inhabited*," we have reason to believe that, in future ages, when the physical and moral energies of mankind shall be fully exerted, and when peace shall wave her olive-branch over the nations, the earth will be much more populous than it has ever been, and those immense deserts, where ravenous animals now roam undisturbed, will be transformed into scenes of fertility and beauty. If it be admitted that the produce of twelve acres of land is sufficient to maintain a family consisting of six persons, and if we reckon only one-fourth of the surface of the globe capable of cultivation, it can be proved that the earth could afford sustenance for 16,000 millions of inhabitants, or *twenty times the number* that is presently supposed to exist.—So that we have no reason to fear that the world will be overstocked with inhabitants for many ages to come; or that a period may soon arrive when the increase of population will surpass the means of subsistence, as some of the disciples of Malthus have lately insinuated. To suppose, as some of these gentlemen seem to do, that wars and diseases, poverty and pestilence, are necessary evils, in order to prevent the increase of the human race beyond the means of subsistence which nature can afford—while the immense regions of New Holland, New Guinea, Borneo, and the greater part of Africa and America are almost destitute of inhabitants—is both an insult on the dignity of human nature and a reflection on the wisdom and beneficence of Divine Providence.—The Creator is benevolent and bountiful, and "his tender mercies are over all his works;" but man, by his tyranny, ambition, and selfishness, has counteracted the streams of Divine beneficence, and introduced into the social state poverty, disorder, and misery, with all their attendant train of evils; and it is not before such demoralizing principles be in some measure eradicated, and the principles of Christian benevolence brought into active operation, that the social state of man will be greatly meliorated, and the bounties of Heaven fully enjoyed by the human race. If, in the present deranged state of the social and political world, it be found difficult in any particular country to find sustenance for its inhabitants, emigration is the obvious and natural remedy; and the rapid emigrations which are now taking place to the Cape of Good Hope, New Holland, New Zealand, Van Dieman's Land, and America, are doubtless a part of those arrangements of Providence, by which the Creator will accomplish his designs, in peopling the desolate wastes of our globe, and promoting the progress of knowledge

and of the true religion among the scattered tribes of mankind.

With that branch of knowledge to which I have now adverted, every individual of the human race ought to be in some measure acquainted.—For it is unworthy of the dignity of a rational being, to stalk abroad on the surface of the earth, and enjoy the bounty of his Creator, without considering the nature and extent of this sublunary habitation, the variety of august objects it contains, the relation in which he stands to other tribes of intelligent agents, and the wonderful machinery which is in constant operation for supplying his wants, and for producing the revolutions of day and night, spring and autumn, summer and winter.—In a religious point of view, Geography is a science of peculiar interest. For "the salvation of God," which Christianity unfolds, is destined to be proclaimed in every land, in order that men of all nations and kindreds and tongues may participate in its blessings. But, without exploring every region of the earth, and the numerous islands which are scattered over the surface of the ocean, and opening up a regular intercourse with the different tribes of human beings which dwell upon its surface, we can never carry into effect the purpose of God by "making known his salvation to the ends of the earth."—As God has ordained, that "all flesh shall see the salvation" he has accomplished, and that human beings shall be the agents for carrying his designs into effect—so we may rest assured, that he has ordained every mean requisite for accomplishing this end; and consequently, that it is his will that men should study the figure and magnitude of the earth, and all those arts by which they may be enabled to traverse and explore the different regions of land and water, which compose the terraqueous globe—and that it is also his will, that every one who feels an interest in the present and eternal happiness of his fellow-men, should make himself acquainted with the result of all the discoveries in this science that have been or may yet be made, in order to stimulate his activity, in conveying to the wretched sons of Adam, wherever they may be found, "the unsearchable riches of Christ."

To the Missionary, and the Directors of Bible and Missionary Societies, a minute and comprehensive knowledge of this science, and of all the facts connected with it, is essentially requisite without which they would often grope in the dark, and spend their money in vain, and "their labor for that which doth not profit." They must be intimately acquainted with the extensive field of operation which lies before them, and with the physical, the moral, and the political state of the different tribes to which they intend to send the message of salvation; otherwise their exertions will be made at random, and their schemes be conducted without judgment or discrimination. To attempt to direct the movements of Missionary Societies, without an intimate knowledge of this subject, is as foolish and absurd as it would be for a land-surveyor to lay down plans for the improvement of a gentleman's estate, before he had surveyed the premises, and made himself acquainted with the objects upon them, in their various aspects, positions, and bearings. If all those who direct and support the operations of such societies were familiarly acquainted with the different fields for missionary exertions, and with the peculiar state and character of the diversified

tribes of the heathen world, so far as they are known, injudicious schemes might be frustrated before they are carried into effect, and the funds of such institutions preserved from being wasted to no purpose. In this view, it is the duty of every Christian, to mark the progress and the results of the various geographical expeditions which are now going forward in quest of discoveries, in connection with the moral and political movements which are presently agitating the nations: for every navigator who plows the ocean in search of new islands and continents, and every traveler who explores the interior of unknown countries, should be considered as so many pioneers, sent beforehand, by Divine Providence, to prepare the way for the labors of the missionary, and for the combined exertions of Christian benevolence.\*

But even to every private Christian, Geography is an interesting branch of study, without some knowledge of which, his prayers and his Christian sympathies cannot be judiciously and extensively directed. We occasionally hear the ministers of religion, at the commencement of public worship on the first day of the week, imploring the Divine blessing on their brethren throughout the Christian Church, who are commencing the same exercises; and at the close of worship in the afternoon; that the same blessing may seal the instructions which have been delivered in all the churches of the saints; as if all the public religious services of the universal Church were at that moment drawing to a close. This is all very well, so far as it goes: the expression of such be-

nevolent wishes is highly becoming, and congenial to the spirit of Christianity. But a very slight acquaintance with geographical science will teach us, that when we in this country are commencing religious services of the first day of the week, our Christian brethren in the East Indies, who live under a very different meridian, have finished theirs; those in Russia, Poland, Greece, Palestine, and on the banks of the Caspian sea, have performed one-half of their public religious worship and instructions; and those in New Holland and Van Dieman's Land have retired to rest at the close of their Sabbath. On the other hand, our friends in the West India islands, and in America, at the close of our worship, are only about to commence the public instructions of the Christian Sabbath. If, then, it be admitted that our prayers, in certain cases, ought to be *specific*, to have a reference to the particular cases and relations of certain classes of individuals, there can be no valid reason assigned, why they should not have a reference to the geographical positions of the different portions of the Christian Church, as well as to those who live on or near our own meridian: that, for example, in the beginning of our public devotions, we might implore that the blessing of God may accompany the instructions which have been delivered in the Eastern parts of the world; and that at the close of the worship, that the same agency may direct the exercises of those in the Western hemisphere, who are about to enter on the sacred services of that day. On the same principle we may perceive the absurdity of those "*concerts*," for praying in different places at the same hour, which were lately proposed, and attempted by a certain portion of the religious world. Even within the limits of Europe, this could not be attempted, with the prospect of Christians joining in devotion at one and the same time; for when it is six o'clock in one part of Europe, it is eight in another, and five o'clock at a third place; much less could such a concert take place throughout Europe, Asia, and America. So that science, and a calm consideration of the nature and relations of things, may teach us to preserve our devotional fervor and zeal within the bounds of reason and propriety; and, at the same time, to direct our reflections and our Christian sympathies, to take a wider range than that to which they are usually confined.

Beside the consideration now suggested, a serious contemplation of the physical objects and movements which this science exhibits, has a tendency to excite pious and reverential emotions. To contemplate this huge globe of land and water, flying with rapidity through the voids of space, conveying its vast population from one region to another, at the rate of fifteen hundred thousand miles in a day, and whirling round its axis at the same time, to produce the constant succession of day and night,—to contemplate the lofty ridges of mountains that stretch around it in every direction; the flaming volcanoes; the roaring cataracts; the numerous rivers, incessantly rolling their watery treasures into the seas; the majestic ocean, and its unfathomable caverns; the vapors rising from its surface, and replenishing the springs and rivers; the avalanche hurling down the mountain's side with a noise like thunder; the luxuriant plains of the torrid zone; the rugged cliffs and icebergs of the polar regions; and thousands of other objects of diversified beauty and sublimity,—has an evident tendency to expand the conceptions of the human mind, to increase its sources of rational enjoyment, and to elevate the

\* On this subject the Author feels great pleasure in referring his readers to a small volume, lately published by James Douglas, Esq., of Chavers, entitled, "*Hints on Missions*,"—a work which deserves the attentive perusal, both of the philosopher, the politician, and the Christian, and particularly of the Directors of Missionary Societies; and which is characterized by a spirit of enlightened philanthropy, and a condensation of thought, which has seldom been equaled in the discussion of such topics. It concentrates, as it were, into a focus, the light of which has been reflected from hundreds of volumes; and the original hints it suggests claim the serious consideration of the superintendents of missionary schemes; without an attention to some of which, the beneficial effects resulting from such undertakings will be few and unimportant.—The following excellent works, recently published on this subject, are warmly recommended to the serious attention of the reader:—1. "*The Great Commission*," by Dr. Harris, President of Chevening College, Author of "*Mammon*," etc.—a prize Essay on Christian Missions, to which the highest prize of 300 guineas was awarded. This work has been generally characterized as "A masterly production, comprehensive in plan, elegant in diction, happy in illustration, cogent and conclusive in reasoning, powerful in appeal, and a book which every Christian in the world ought to read." 2. "*Missions*," their authority, scope, and encouragement," by the Rev. Richard W. Hamilton, Leeds, to which the second prize of the Association alluded to above was adjudged. This work has likewise been characterized by properties somewhat similar to those which have been applied to "*The Great Commission*," and the Author has been eulogized as a writer of great power and originality.—3. "*The Jubilee of the World*," by the Rev. J. MacFarlane, Minister of Coleridge, published at the recommendation of four of the adjudicators of the Missionary Prize Essays—a volume which is justly considered as "the production of a well-disciplined mind, accustomed to think deeply and accurately on any subject to which its energies might be directed,—that its tone and temper are decidedly evangelical, its spirit eminently catholic, and its appeals stirring and appropriate."—4. "*Christian Missions to Heathen Nations*," by the Honorable Baptist W. Noel, M. A. Though this volume is not considered equal to Mr. MacFarlane's in point of close argument and logical deduction, yet it has the advantage of it as a *practical* treatise on missionary work, and evinces a minute acquaintance with the whole scene of missionary labors, which, *on this respect*, is considered by some as superior to any of the other essays. Were these works carefully perused by the great mass of the Christian world, their spirit imbued, and their practical suggestions carried into effect, the world would, ere long, be regenerated, and the dawn of the Millennial era would soon make its appearance.

affections to that All-powerful Being who gave birth to all the sublimities of Nature, and who incessantly superintends all its movements.

In fine, from the numerous *moral* facts which Geography unfolds, we learn the vast depth and extent of that moral degradation into which the human race has fallen—the ferocious tempers, and immoral practices, which are displayed in the regions of Pagan idolatry—the horrid cruelties, and vile abominations, that are daily perpetrated under the sanction of what is termed Religion—the wide extent of population over which the prince of darkness sways his scepter—the difficulties which require to be surmounted, before “the Gospel of salvation” can extend its full influence throughout the Pagan world—and the vast energies which are requisite to accomplish this glorious event. All these portions of information are calculated to confirm and illustrate the scriptural doctrine of the universal depravity of man—to exercise the faith of the Christian on the promises of Jehovah, in reference to the conversion of the benighted nations—to arouse his sympathies toward his degraded brethren of mankind, to excite his intercession in their behalf, and to direct his benevolence and activity, in devising and executing schemes for enlightening the people who are sitting “in darkness, and in the shadow of death.”

#### GEOLOGY.

Another subject intimately related to the former, is the science of Geology.

This science has for its object, to investigate and describe the *internal structure* of the earth, the arrangement of the materials of which it is composed, the circumstances peculiar to its original formation, the different states under which it has existed, and the various changes which it appears to have undergone since the Almighty created the substance of which it is composed. From a consideration of the vast quantity of materials contained in the internal structure of our globe, and of the limited extent to which men can carry their operations, when they attempt to penetrate into its bowels, it is obvious that our knowledge of this subject must be very shallow and imperfect. The observations, however, which have been made on the structure of our globe during the last half century, and the conclusions deduced from them, are highly interesting both to the philosopher and to the Christian. Before the facts on which this branch of Natural History is founded, were accurately ascertained, various objections to the Mosaic history of the creation were started by certain sceptical philosophers, founded on partial and erroneous views of the real structure and economy of the earth; but it is now found, that the more accurately and minutely the system of nature is explored, the more distinctly do we perceive the harmony that subsists between the records of Revelation and the operations of the Creator in the material world. If both be admitted as the effects of the agency of the same Almighty and Eternal Being, they must, in the nature of things, completely harmonize, and can never be repugnant to each other—whether we be capable in every instance of perceiving their complete coincidence or not. If any facts could be produced in the visible creation which directly contradicted the records of the Bible, it would form a proof, that the oracles which we hold as Divine were not dictated by the Creator and Governor of the Universe. But although some garbled facts have been triumphantly exhibited in this view; it is now ascertained, from

the discoveries which have been lately made in relation to the structure and formation of the earth, that the truth of the facts detailed in Sacred History rests on a solid and immutable basis; and that the Supreme Intelligence who arranged the fabric of heaven and earth, and he alone, communicated to the inspired writers the doctrines and facts they have recorded: and we have reason to believe, that as Geologists proceed in their researches and investigations, still more sensible proofs of the authenticity of Revelation will be brought to light.

Geology has of late become an interesting object of inquiry to the student of general science, and is now prosecuted with ardor by many distinguished philosophers. The observations which have been made in various parts of the world by late navigators; the facts which have been ascertained by Pallas, Saussure, De Luc, Humboldt, Lyell, Sedgwick, and other intelligent travelers; and the discoveries which have been brought to light by modern chemists and mineralogists, have all conspired to facilitate Geological inquiries, to render them more enlightened and satisfactory, and to prepare the way for future ages establishing a rational, scriptural, and substantial theory of the earth. The man who engages at such inquiries has always at hand a source of rational investigation and enjoyment. The ground on which he treads—the aspect of the surrounding country—the mines, the caves, and the quarries which he explores—every new country in which he travels, every mountain he climbs, and every new surface of the earth that is laid open to his inspection, offer to him novel and interesting stores of information. On descending into mines, we are not only gratified by displays of human ingenuity, but we also acquire views of the strata of earth, and of the revolutions it has undergone since the period of its first formation. Our researches on the surface of the earth, amidst abrupt precipices and lofty mountains, introduce us to the grandest and most sublime works of the Creator, and present to our view the effects of stupendous forces, which have overturned mountains, and rent the foundations of nature. “In the midst of such scenes, the Geologist feels his mind invigorated; the magnitude of the appearances before him extinguishes all the little and contracted notions he may have formed in the closet; and he learns, that it is only by visiting and studying these stupendous works, that he can form an adequate conception of the great relations of the crust of the globe, and of its mode of formation.”\*

At first sight, the solid mass of the earth appears to be a confused assemblage of rocky masses, piled on each other without regularity or order, where none of those admirable displays of skill and contrivance are to be observed, which so powerfully excite attention in the structure of animals and vegetables. But on a nearer and more intimate view; a variety of beautiful arrangements has been traced by the industry of Geologists, and the light of modern discoveries; by which they have been enabled to classify these apparent irregularities of nature. The rocks of which the crust of the earth is chiefly composed, occur in beds or layers, each of which is distinguished by its peculiar characteristic. 1. The first class is what has been denominated **PRIMARY** Rocks. These constitute the great framework, or primitive envelope of the globe. They form the most lofty mountains, and at the same time extend downward below all the other formations

\* Edinburgh Encyclopædia, Art. *Mineralogy*



to the greatest depths yet penetrated by man, and constitute everywhere the foundation on which the other rocks are supported. It is, therefore, supposed that they were the earliest formed, in the progress of creation; and are hence denominated *primitive* or *primary* rocks. One of the principal rocks of this class is *granite*, which is compounded of *quartz*, *feldspar*, and *mica*. *Gneiss*, or *slaty granite*, is considered as another species; and *mica slate* a third species of the primitive rocks. There are some other primary rocks which occur imbedded in, and interstratified with the principal primitive rocks. They are called *subordinate rocks*, and are named as follows:—*Hornblende* rock, *Serpentine*, *Crystalline Limestone*, *Quartz* rock. The

Fig. 15.



Fig. 16.

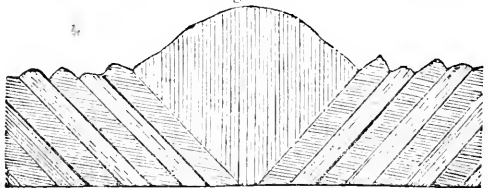
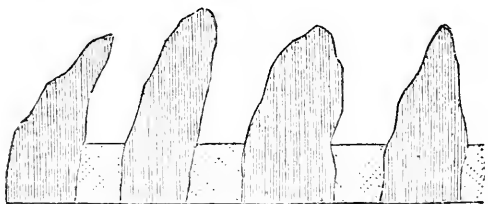

Fig. 17.



the primeval ocean, when the disruptions caused by such powerful and mighty movements, reduced the higher parts of the primitive to fragments. These shattered fragments becoming agglutinated by their own pulverent cement, recomposed continuous strata which form the rocks to which we allude. In this class of rocks we first behold the rudiments of vitality—the dawn of organization—the first-born of earthly creatures, whose existence is recorded in imperishable characters. These consist of organized beings of the lowest orders, such as sea-shells of various descriptions, which are here found imbedded, and which afford a decisive evidence that such rocks were formed *after* the creation of organized beings—the rocks belonging to this class are *Transition* or *mountain limestone*—*Graywacke*, and *graywacke slate*—*Slate* and its varieties. Roof-slate, and the slate of which school slates are made, are well known varieties of this rock. It is sometimes called *clay-slate*, *argillaceous slate*, and *argillaceous schistus*. Transition rocks are the principal repositories of metallic ores, which occur both in beds and veins more abundantly in many of the rocks of this class than in primary rocks.

3. The next class is the **SECONDARY ROCKS**, which lie upon the transition rocks, and appear like deposits composed of grains which once be-

three principal rocks of this class, granite, gneiss, and mica slate, might with propriety be regarded as belonging to one formation. They are composed *essentially* of the same minerals, varying in different proportions, and are rather modes of the same rock than different species. They pass by gradations into each other, as one or other of their constituent minerals becomes more or less abundant; they alternate with each other in various situations, and may be regarded as contemporaneous.—Granite is considered as the foundation rock, on which slate and all secondary rocks are laid. When granite rises above the surface, the beds of other rocks in the same district rise toward it, and lie against it, as in fig. 15; but there are instances in which they appear to pitch under the granite, as in the next figure. The aspect of granite mountains is extremely various. When the beds are horizontal, or when the rock is soft and disintegrating, the summits are rounded and unpicturesque. (See fig. 16.) When hard and soft granite occur in the same mass, the soft decomposes, and leaves the hard in large, loose masses upon the soil, or if they lie in alternate and highly inclined beds, the hard granite forms high and almost inaccessible peaks, as seen in fig. 17.

The structure of primary rocks is *crystalline*—(see fig. 17), they form the central parts of the most elevated mountain-chains—they never contain the fragments of other rocks—and they are particularly distinguished from all other formations in this,—that they contain no remains of organized substances. There also appears conclusive evidence, that materials composing granite, of which this class of rocks chiefly consists, were once in a state of fusion.

2. The class of rocks next in order to the primitive are what are termed **TRANSITION ROCKS**,—which are next and above the primitive on which they rest. This formation is composed of the larger fragments of all the primitive rocks consolidated into continuous masses. It is supposed that these rocks were formed, when the primary rocks were thrown up from the bed of

longed to primitive rocks. Geologists now divide these rocks into *upper secondary* and *lower secondary*. The principal secondary formations are: (1.)—The *coal* formation, in the lower secondary series, and the *rock-salt* or *saliferous* formation in the upper secondary. The strata of the coal formation are numerous, extensive, and parallel; but they are often beset, undulating, curved, broken, and contorted in various ways. The strata connected with the coal bear evidences, in some instances, of having been rapidly deposited, as in the cases where we find the vertical stems of plants standing in their natural position, in many coal mines, and the rocks deposited around them in horizontal or slightly inclined strata. The stems of arborescent plants, two or three feet in diameter, are thus found piercing through the strata many feet. In such a case, the sand mud must have been deposited within a comparatively short time around them, otherwise in a climate such as that in which these plants grew, they would have decayed and left no indications of their existence.—Coal occurs in regular strata which vary in thickness from a few inches to several feet or yards. In the same coal formations many strata of coal occur under each other separated by a stratum of shale, sandstone, etc. The series of strata which occur together is called a *coal field*

Coal fields are of limited extent, and the strata often dip to a common center, being often arranged in basin-shaped cavities, which appear to have been originally detached lakes that were gradually filled up by repeated depositions of car-

bonaceous and mineral matter. The different strata over and under the beds of coal are frequently similar, and the same series of strata is repeated for each successive stratum of coal, as shown in fig. 18. Coals are generally supposed

Fig. 18.

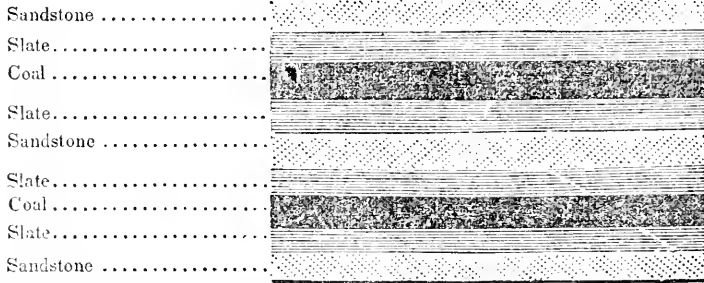

to have had a *vegetable* origin; and, when we consider the abundance of vegetable remains usually found in connection with coal, and the vegetable structure which the coal itself sometimes exhibits, we can hardly doubt as to its origin. At most coal mines, even the thinnest layers of slate, when split off, show the impressions of the leaves and flat stems of the various grasses, reeds, and ferns, in all their most delicate parts. The impressions between the layers of slate sometimes give as perfect a representation of the plant, as if the plant had been pressed and dried in a book, and the leaves then opened to display it.

(2.) The *upper secondary* rocks comprise all the different formations above the great coal formations, to the upper limit of the chalk series. These rocks are divided into the three following formations. 1. *Chalk*, or cretaceous rocks, including the ferruginous and green sand. 2. *Oolitic Rocks*, lias limestone, and lias clay. 3. *Red Sandstone*, including magnesian limestone.—The red sandstone formation is characterized by the first appearance of the remains of the *Saurian*, or lizard-shaped animals. The remains of a number of species have been found, differing in their appearance from the crocodile and alligator, some of which must have been from 60 to 120 feet in length. These animals appear to have lived in salt water, unlike any of this class with which we are acquainted at the present day, all of which belong either to the land or to fresh water. They had neither feet nor fins, but paddles like the sea turtle, and their tails were long, of the form of an oar, and fitted to propel them through the most agitated waters. The *Oolitic* rocks are composed of various strata of limestone, clay, sand, and sandstone. *Oolite* derives its name from the small globules that are imbedded in this species of rock—some of the masses of which appear composed of little rounded globules like the *roes* of fish. These rocks are remarkable for the great variety of organic remains they contain. The animal remains are those belonging to the land, and to fresh water. The teeth and bones of fish and reptiles are abundant. The reptiles are mostly *saurian* animals and turtles. Among these are the *Megalosaurus*, the *Plesiosaurus*, and the *Iguanodon*, some of which must have been at least 70 feet in length, and of the height of an elephant. There are also *vegetable* fossils in these rocks.—consisting of arborescent forms, trunks of palms, gigantic reeds, and similar vegetable productions, which are now to be found growing only in the Torrid Zone.

4. The next division is the *TERTIARY*, which is considered as having been deposited after the *Secondary*. The strata comprehended under this class consist of beds of clay, marl, sand, puddingstones, and imperfectly consolidated limestone, which appear to have been deposited since the chalk formation. The tertiary deposits contain no beds of minerals or metallic veins, capable of exploration, except lignite and jet, which are used for fuel and ornament,—clay for pottery, sand for the manufacture of glass, pyrites for the manufacture of coppers and alum, and a valuable iron ore called hydrate of iron. This formation, however, abounds with a vast quantity of vegetable and animal remains, such as crocodiles, crabs, lobsters, several species of vertebral fish, and a vast number of testaceous exuviae; so well preserved as to have the appearance of recent shells. The most remarkable discovery that has been made respecting the Tertiary deposits is, that many of them contain the bones of *mammiferous animals* (that is those which suckle their young) as perfect in their organization as any of the existing species of land animals; but most of them belong to genera or species that are extinct. These strata are further remarkable for presenting the frequent alternation of beds containing the remains of marine animals, with other beds that contain the bones of land animals or fresh water shells. The city of Paris, in France, and the country around, which are situated upon a tertiary deposit, which rests upon chalk—are remarkable for the extraordinary organic remains which they contain. Millions of marine shells compose the principal mass. Bones of marine animals, of which the genera are entirely unknown, are found in certain parts. Other bones, remarkable for their vast size, and of which some of similar genera exist only in distant countries, are found scattered in the upper beds. Not only the remains of sea animals and land quadrupeds, but also those of birds, are found in this deposit, such as the duck, the pelican, the woodcock, the starling, and the skylark. The famous locality of fossil fish at Monte Bolca, in Italy, is in tertiary strata. About 105 species have been found in those quarries, and many of them are different from any species known to exist in the neighboring seas, or even in any part of the earth.

5. The next distinction of formations made by Geologists is *DILUVIAL* and *Alluvial* deposits—the former being generally considered as having been formed by the last general deluge, and the latter by currents of rivers and other causes now in

operation. The blocks of rock and the beds of gravel spread or scattered on the surface of the ground, composed of stone or fragments foreign to the district in which they are spread, and which frequently cover the bones of unknown species of quadrupeds—are called *Diluvial* depositions, that is, depositions which have been caused by a deluge. The materials of these deposits are usually coarse, and composed of gravel, pebbles, and blocks of a great variety of rocks aggregated without any regularity. The sand, soil, or fragments brought down by rivers, and spread along their banks or at their mouths, are called *alluvial* depositions. The bones and skeletons of large animals, and especially the *Mammoth*, are found in diluvial gravel in many countries. In Siberia, the tusks of the fossil elephant are found in the diluvial banks of almost every river, and sometimes in such abundance that the ivory from these skeletons is an article of export. It is said that the skeleton of a whale lies on the top of mountains 3000 feet high on the coast of the Northern ocean, which could scarcely have been conveyed to such an elevation but by an immense overwhelming deluge.

ALLUVIAL deposits are the most superficial of all the formations; they are forming every day; they envelop the remains of animals that still exist on the surfaces they have formed, and they are also mingled with the remains of animals which have existed in recent times. The alluvial beds, taken as masses, are all of loose earth, and are never covered by rocky masses; and in these beds chiefly are to be found the remains of human beings and the monuments of their industry and art. There is a constant tendency in torrents, currents, rivers, tides, winds, and similar causes, to wear down the inequalities of the land and deposit the materials in the sea. In this way *deltas* have been formed, such as the deltas of the Nile, the Ganges, the Mississippi, the Danube, and the Rhone. The mouths of the Mississippi are now more than 100 miles from its original entrance into the gulf of Mexico, and for hundreds of miles above most of the land seen from its banks is alluvial; so that all the mass of land alluded to has been formed by materials carried down by the rapid current of this mighty river. The delta of the Ganges commences 224 miles in a direct line from the ocean; and the town of Adria, which was once a port on the Adriatic, is now 20 miles inland; all which vast accumulations are considered as the effects of Alluvial depositions.

6. There is likewise a species of Rocks distinguished by Geologists by the title of Volcanic and Basaltic rocks; which owe their origin to volcanic fire, and are sometimes forced up to the surface of the earth by the action of subterranean heat. The principal volcanic rocks are *basalt*, *lava*, and *greenstone*. Volcanic rocks occur in shapeless masses, and are destitute of organic remains. In some parts of Europe, as in Iceland, Sicily, and the country around Naples, active volcanoes still exist, which frequently emit vast quantities of lava, ashes, and other species of matter. But even in places where no active volcanoes exist, as in Auvergne, Velay, and Vivarais, in France, several hundreds of conical hills are found, with craters near their summits. These hills are composed of materials similar to those of active volcanoes, and streams of lava may sometimes be traced proceeding from the cones into the adjoining valleys, where they choke up the ancient channels of rivers, in the same manner as some of the modern lavas in Iceland have been known to do, the rivers either flowing be-

neath, or cutting out a passage on one side of the lava.—TRAP rocks are related to volcanic, and are mostly composed of hornblende and felspar. The term *trap* is derived from the German word *trapp*, a stair, as many of these rocks occur in a terrace form, or like the steps of a stair—a configuration which is supposed to be owing to the stopping of large sheets of lava when flowing, whether at the bottom of the sea or on dry land; for it is known that streams of lava generally terminate in abrupt precipices, similar to the beds constituting the trap ranges. These rocks are distinguished, even at a distance, from those of the stratified formations, as they occur in shapeless masses, and form hilly tracts of great irregularity of surface, or in the form of walls or *dikes* penetrating other rocks, which they alter in character to a certain degree at this point of contact.

*Basalt* is of a black or bluish-gray color. It is commonly fine-grained, and consists of an intimate admixture of felspar and augite, a variety of hornblende, with some oxyd of iron. Many of the Western Islands of Scotland are wholly or almost composed of basalt. The island of *Staffa* is a complete mass of basalt. It is about two miles in circumference, and is surrounded on every side by steep cliffs, 70 feet high, formed of clusters of angular columns, containing from 5 to 7 sides each. Fingal's cave is in the S. E. corner of the island, and presents a magnificent chasm, 42 feet wide, and 227 in length. The roof, which is 100 feet high at the entrance, gradually diminishes to 50, and is composed of the projecting extremities of basaltic pillars, and the base of a causeway of the same materials.—The *Giant's Causeway*, in the county of Antrim, in Ireland, is another striking specimen of basaltic columns. It consists of hundreds of thousands of pentagonal and hexagonal columns (that is, columns of 5 and 6 sides) varying from 1 to 5 feet in thickness, and from 20 to 200 feet in height. The district in which this remarkable formation occurs lies on both sides of the river Bann, and comprehends an area of 800 square miles.—Throughout this area, the basalt is found occupying all the eminences, and constituting an overlying bed of igneous rocks, at least 500 feet in thickness. The greatest mass of basalt yet known occurs in the province of Deccan in India, where it constitutes the surface over an area of many thousand square miles.

Having given the above brief sketches of the different orders of stratification, I shall conclude this department of the subject, by a few general statements respecting the organic remains imbedded in the several formations to which we have adverted.

1. Organic remains are not found promiscuously scattered through the rocks, but each formation has its peculiar group of animals and plants; and on comparing together the larger groups of strata, we find scarcely any organic remains common to any two of them. These fossil animal and plants are found together in groups, very much as living plants and animals are—different groups occupying different portions of the surface of the earth and of the ocean. Hence it is concluded, that these remains were once living plants and animals, which, in different periods, occupied the ocean and the dry land, grouped together as we now find them, and that, as they died, they became enveloped in rock, near the places where they passed their existence.

2. Some of the formations and deposits to which we have alluded, particularly the *Mountain limestone*, consist almost entirely of the shells and cor-

ralline productions of sea animals, and this formation is often a thousand or more feet in thickness, and many miles in length and breadth. In what are termed the *Silarian* formations is found a long succession of strata many thousand feet in thickness, and imbedding not fewer than 375 species belonging to the animal kingdom.

3. It is considered as an established fact, that of more than 3000 species of plants and animals that are found in a fossil state in the secondary rocks, not a single species corresponds with any now living on the globe; and even out of 3000 fossil species in the Tertiary formation less than 600 are identical with living species. In short, in all the different formations, until we come to the uppermost and the newest, the thousand species they contain are all different from any in the now existing creation, though possessing family analogies.

4. It is a remarkable fact, that notwithstanding the great variety of fossils observed in the early formations, the remains of *Man* are not to be found in these formations. The remains of human beings and the vestiges of the arts and operations of man are discovered only in or upon those earthly masses which are demonstrably posterior to all regular geological deposits—or, the Diluvial and Alluvial formations—and under circumstances indicating the human species to have been among the recent productions of the Creator's power, and that man was created at a period posterior to those great changes and convulsions which destroyed so many millions of millions of animated beings. Had this not been the case, it is almost certain that numerous remains of the human species would have been found in the early formations.

"The phenomena of Geology show that the original formation of the rocks has been accompanied, in nearly all its stages, by a process of waste, decay, and recomposition. The rocks, as they were successively deposited, were acted upon by air and water, heat, etc., broken into fragments or worn down into grains out of which new strata were formed. Even the newer secondary rocks, since their consolidation, have been subject to great changes, of which very distinct monuments remain. Thus, we have single mountains, which from their structure can be considered only as remnants of great formations, or of great continents no longer in existence.—Mount Meisner, in Hesse, six miles long, and three broad, rises about 1800 feet above its base, and 2100 above the sea, overtopping all the neighboring hills for 40 or 50 miles round. The lowest part of the mountain consists of the same shell, limestone, and sandstone, which exist in the adjacent country. Above these are, first, a bed of sand, then a bed of fossil wood 100 feet thick at some points, and the whole is covered by a mass of basalt, 500 feet in height. On considering these facts it is impossible to avoid concluding, that this mountain which now overtops the neighboring country, occupied at one time the bottom of a cavity in the midst of the higher lands. The vast mass of fossil wood could not all have grown there, but must have been transported by water from a more elevated surface, and lodged in what was then a hollow. The basalt which covers the wood must also have flowed in a current from a higher site; but the soil over which the basalt and the wood passed has been swept away, leaving this mountain as a solitary memorial to attest its existence. Thus also on the side of Mount Jura next the Alps, where no other mountain interposes, there are found vast blocks of granite

(some of them of 1000 cubic yards) at the height of more than 2000 feet above the lake of Geneva. These blocks are foreign to the rocks among which they lie, and have evidently come from the opposite chain of the Alps; but the land which constituted the inclined plane over which they were rolled or transported has been worn away, and the valley of Lower Switzerland, with its lakes, now occupies its place. Transported masses of primitive rocks of the same description are found scattered over the north of Germany, which Von Buch ascertained, by their characters, to belong to the mountains of Scandinavia; and which therefore carry us back to a period when an elevated continent, occupying the basin of the Baltic, connected Saxony and Norway."\*

The production of a bed for *vegetation* is effected by the decomposition of rocks. This decomposition is effected by the expansion of water in pores or the fissures of rocks, by heat or congelation, by the solvent power of moisture, and by electricity, which is known to be a powerful agent of decomposition. As soon as the rock begins to be softened, the seeds of *lichens*, which are constantly floating in the air, make it their resting-place. Their generations occupy it until a finely divided earth is formed, which becomes capable of supporting mosses and heath; acted upon by light and heat, these plants imbibe the dew and convert constituent parts of the air into nourishment. Their death and decay afford food for a more perfect species of vegetable; and at length a mold is formed, in which even the trees of the forest can fix their roots, and which is capable of rewarding the labors of the cultivator.—The decomposition of rock tends to the *renovation* of soils, as well as their cultivation. Finely divided matter is carried by rivers from the higher districts to the low countries, and alluvial lands are usually extremely fertile. By these operations the quantity of habitable surface is constantly increased; precipitous cliffs are gradually made gentle slopes, lakes are filled up, and islands are formed at the mouths of great rivers; so that, as the world grows older, its capacity for containing an increased number of inhabitants is gradually enlarging.

Of all the memorials of the past history of our globe, the most interesting are those myriads of remains of organized bodies which exist in the interior of its outer crusts. In these, we find traces of innumerable orders of beings existing under different circumstances, succeeding one another at distant epochs, and varying through multiplied changes of form. "If we examine the secondary rocks, beginning with the most ancient, the first organic remains which present themselves are those of aquatic plants and large reeds, but of species different from ours. To these succeed madrepores, encrenites, and other aquatic zoophytes, living beings of the simplest forms, which remain attached to one spot, and partake, in some degree, of the nature of vegetables. Posterior to these are ammonites, and other mollusci, still very simple in their forms, and entirely different from any animals now known. After these, some fishes appear; and plants, consisting of bamboos and ferns, increase, but still different from those which exist. In the next period, along with an increasing number of extinct species of shells and fishes, we meet with amphibious and viviparous quadrupeds, such as crocodiles and tortoises, and some reptiles, as serpents, which show that dry land

\* Supplement to the Encyclopedia Britannica, 6th edit vol. vi.

now existed. As we approach the newest of the solid rock formation, we find lamantins, phocæ, and other cetaceous and mammiferous sea animals, with some birds. And in the newest of these formations, we find the remains of herbiferous land animals of extinct species, the paleotherium, anaplotherium, etc., and of birds, with some fresh water shells. In the lowest beds of loose soil, and in peat bogs, are found the remains of the elephant, rhinoceros, hippopotamus, elk, etc., of different species from those which now exist, but belonging to the same genera. Lastly, the bones of the species which are apparently the same with those now existing alive, are never found except in the very latest alluvial depositions, or those which are either formed in the sides of rivers, the bottom of ancient lakes and marshes now dried up, in peat beds, in the fissures and caverns of certain rocks, or at small depths below the present surface, in places where they may have been overwhelmed by debris, or even buried by man. Human bones are never found except among those of animal species now living, and in situations which show that they have been, comparatively speaking, recently deposited.\*

Numerous species of animals have been found imbedded in the secondary strata—no living examples of which are now to be found in any quarter of the globe. Among the most remarkable of these are the following:—1. The *Mammoth*, which bears a certain resemblance to the elephant, but is much larger, and differs considerably in the size and form of the tusks, jaws, and grinders. The fossil remains of this animal are more abundant in Siberia than in other countries; there being scarcely a spot, from the river Don to Kamschatka, in which they have not been found. Not only single bones and perfect skeletons of

this animal are frequently to be met with; but, in a late instance, the whole animal was found preserved in ice. This animal was discovered on the banks of the frozen ocean, near the mouth of the river Jena, in 1799; and in 1805, Mr. Adams got it conveyed over a space of 7000 miles to Petersburg, where it is deposited in the museum. The flesh, skin, and hair, were completely preserved, and even the eyes were entire. It was provided with a long mane, and the body was covered with hair. This hair was of different qualities. There were stiff black bristles from twelve to fifteen inches long, and these belonged to the tail, mane, and ears. Other bristles were from nine to ten inches long, and of a brown color; and beside these, there was a coarse wool, from four to five inches long, of a pale yellow color. This mammoth was a male; it measured nine feet four inches in height, and was sixteen feet four inches long, without including the tusks. The tusks, measuring along the curve, are nine feet six inches; and the two together weigh 360 lbs. avoirdupois. The head alone, without the tusks, weighs 414 lbs. avoirdupois. The remains of this animal have been found likewise in Iceland, Norway, Scotland, England, and in many places through the continent onward to the Arctic ocean.

2. The *Megatherium*. A complete skeleton of this colossal species was found in diluvial soil near Buenos Ayres, and sent to Madrid. The specimen is fourteen feet long, and seven Spanish feet in height.

3. The Great *Mastodon* of the Ohio, of which the following figure is a representation. This species appears to have been as tall as the elephant, but with longer and thicker limbs. It had tusks like the elephant, and appears to have lived on roots. Its remains abound in America, particularly on the banks of the Ohio.

Fig. 19.

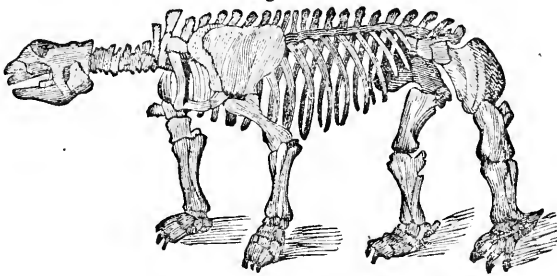

4. The *Tapir*, which also abounds in America. The one named *Gigantic Tapir*, is about eighteen feet long, and twelve feet high.

5. The *Irish Elk*, or Elk of the Isle of Man. This gigantic species, now apparently extinct, occurs in a fossil state, in Ireland, Isle of Man, England, Germany, and France. The most perfect specimen of this species, which was found in the Isle of Man, may be seen in the museum of the University of Edinburgh. It is six feet high, nine feet long, and in height, to the tip of the right horn, nine feet seven and a half inches.†

Such are a few of the facts which the researches of modern Geology have disclosed. Let us now consider what are the conclusions which have been deduced from them.

One of the grand conclusions which has been

deduced by modern geologists—even by those who acknowledge the divinity of the Christian Revelation, is, that *the materials of which our globe is composed are of very high antiquity*, and were brought into existence long before the race of Adam was placed upon the earth. The exact period of years which any of these materials may have existed, or any approximation to it, no geologist has yet undertaken to determine, nor is it likely that the problem will ever be satisfactorily solved. In reference to some of the coal strata, Mr. Macculloch, in his "System of Geology," states that it would be even too short a period "were we to allow 200,000 years for the production of the coal mines of Newcastle with all its rocky strata," not including the subsequent formations up to the present condition of the earth. Mr. Maclaren, in his "Geology of Fife and the Lothians," estimates a single period of volcanic quiescence, during which strata of coal, shale, sandstone, and limestone, were deposited over the

\* Sup. to Encyc. Brit., vol. vi.

† An Engraving of this skeleton may be seen in Vol. Sixth of Sup. to Encyc. Brit., 6th edit.

side of Arthur's Seat, a basaltic hill in the vicinity of Edinburgh—at *five hundred thousand years*. Mr. Babbage, when referring to the tertiary class of formations, regards it as a truth, supported by irresistible evidence, “that the formation even of those strata which are nearest the surface, must have occupied vast periods, probably millions of years.”\* The Rev. Professor Seignwick, when adverting to the process of forming deposits, says, that “a section of a few perpendicular feet indicates a *very long* lapse of time,” so that in such processes “many thousands of years sink into a trifling period.” In short, the most respectable modern geologists, when alluding to this point, use such expressions as the following—“immense periods of time”—“a duration to which we dare not assign a boundary”—“undefined ages”—“a long succession of monuments, for the production of each of which there may have been required a thousand ages”—“successions of events, where the language of nature signifies millions of years”—“a duration which it would be presumptuous to put into an estimate of years and centuries”—with many other expressions of a similar import. Whether such strong and unlimited expressions be warranted by the nature of the processes alluded to, I do not take upon me to determine.

2. Another conclusion which has been deduced from the above stated facts, is, that during the changes which the globe has undergone, since its original production out of nothing, *several destructions and subsequent new creations of animals and plants have taken place*, perhaps at very different and very distant epochs. The greater part of geologists conclude, that four or five distinct epochs of destruction and renewal may be traced in the organic remains contained in the different strata; in other words, that whole groups have been swept at once from existence by some powerful catastrophe, and their places supplied by other races, called into existence by the creating energy of the Almighty. The records of geology seem to testify that such was the condition of the globe, in those early periods, as to temperature and other circumstances, that our present races of animals could not have then existed, and that such was the nature and constitution of these primeval beings, that they could not exist in the present constitution and circumstances of our globe; their natures being adapted to the different conditions of the earth, at different periods of its existence.

3. A third conclusion is, that the *successive changes to which our globe has been subjected, have been improvements in its condition as a habitable world*, that there has been a correspondent advance toward perfection in the natures of the animals and plants which have been placed upon its surface; and that the *Deity, during this long period of successive changes, was gradually fitting up this world for the ultimate residence of moral and intellectual beings*, such as the human species that now inhabit it. For it appears next to certain that the race of man could not have inhabited this globe in any of the past periods of its duration, prior to that era in which he was placed upon it. It would appear that the Deity did not think proper to prepare a suitable habitation for man by a *miracle*, or a direct interposition of his Almighty energy, but by the agency of those physical laws which he had impressed upon the elementary principles of the material universe. And in order that matter might not exist in vain, my-

riads of beings were brought into existence, under the direction of Infinite Wisdom, endowed with faculties and natures adapted to those peculiar states of the terraqueous globe in which they were to pass their existence.

Such are a few of the facts connected with the constitution of our globe, and the conclusions which have been deduced from them. It now remains that we inquire into their accordance with the records of the Sacred history.

It has been too frequently taken for granted by theologians and commentators, that the whole system of the material universe was brought into existence within the period of 6000 years from the present time; and hence, some of them who have been anxious to reconcile the Mosaic and Geological chronologies, have attempted to show that all the formations and changes in the strata of the earth, to which we have alluded, might have been effected within the period of 6000 years, and particularly during the continuance of the deluge in the days of Noah. Some of them have insinuated that the *coralline reefs*, which exhibit vast accumulations of calcareous matter, and which abound on the coast of New Holland, and among the islands of the Pacific ocean, have been all formed since the present order of things commenced; and therefore that all the other formations to which we have already alluded, even the oldest, may have been formed within the same period. It has also been insinuated, that it appears derogatory to the Wisdom and Power of the Creator to suppose, that for thousands of years the earth should have been occupied merely with vegetables and animals of the lowest orders, and that many species of each class were alternately created, and permitted to retire out of existence.

But such positions are now considered as absolutely untenable by all the most scientific and respectable geologists of modern times, as being inconsistent with facts that are everywhere perceptible in the strata of our globe. As to the designs which the Almighty had in view, in replenishing the earth for so long a period of time, chiefly with the inferior ranks of existence, and again permitting them to perish, it becomes us to speak with reverence and humility, as beings whose faculties are limited, and altogether inadequate to trace the inscrutable paths of the Divinity, or to investigate the reasons of every part of his procedure. We cannot, in many cases, decide as to what is consistent or inconsistent with the attributes of the Almighty; and, in the present case, as well as in many others, we must admit that the operations of the Deity are unsearchable, and “his ways past finding out.” “Canst thou by searching find out the secrets of God? Canst thou find out the designs of the Almighty? they are as high as the heavens, deeper than hades; the measure thereof is longer than the earth and broader than the sea.” But this we know that, in consequence of the previous revolutions which our globe has undergone, it was prepared for being a suitable habitation for the human species, and for the other ranks of animate nature that now possess it; and although some portions of it present the appearance of desolation and disarrangement, yet were man its chief inhabitant, renovated in the spirit of his mind, and found acting on the moral principles of Christianity, in the capacity of communities and nations, it might soon be cultivated and renovated throughout all its extent, so as to present

\* Babbage's Ninth Bridgewater Treatise.

the aspect of a terrestrial paradise, and to shine forth with all the beauties of Eden.

But, to come more particularly to the subject in hand. Had Moses, in his history of the Creation, positively declared that every portion of the material world was created out of nothing, within 1653 years of the period of the deluge, or about 6090 years ago, it would be difficult, if not impossible, to reconcile the facts of geology with the Mosaic history. But no such position is to be found either in the writings of Moses or throughout any other portion of sacred Scripture. For the illustration of this point, it may be proper for a little to consider the meaning and import of the 1st verse of the first chapter of Genesis: "*In the beginning God created the heavens and the earth.*"

This proposition is to be considered as a *Preface* to the following narrative of the arrangements connected with our terrestrial system, and, indeed, to the whole of Divine Revelation; and a more comprehensive, emphatic, and *appropriate* introduction can scarcely be conceived. By the *heavens and the earth*, we are here undoubtedly to understand the whole frame of the material universe, with all the bodies it contains, wherever existing throughout immensity—whether suns, planets, comets, nebulae, or whatever else exists throughout the regions of boundless space. All the bodies comprehended under this general expression are here said to have been *created*, that is, brought from nothing into existence by the energy of an Eternal and Omnipotent agent. The original Hebrew word, *Bara*, does not indeed necessarily convey this idea, as it most frequently signifies "to produce something new or wonderful," or "to arrange, to renovate, or new-model" something which was previously in existence. It is a matter of rational inference, however, and strictly accordant with just philosophical principles, that the material universe was *created out of nothing*. It is such an inference as cannot be resisted without doing violence to the fundamental laws of human belief. This magnificent frame of the universe is here said to have been brought into existence by God, the God of Israel, the Self-existent and Eternal Jehovah. This declaration was intended to teach the Israelites, and all others, that the material world as to its original atoms, did not arise without a cause, or out of pre-existent materials; that the beautiful order it now exhibits did not originate from the fortuitous concurrence of atoms, as some heathen philosophers imagined, and that it did not derive its existence from any of the gods of the nations, as some of their blinded worshippers foolishly imagined. In opposition to all such chimerical, absurd, and atheistical notions, Moses declares, "In the beginning God"—the God of Israel—"created the heavens and the earth." As if he had said, That God who delivered you from the land of Egypt, after having displayed so many signs and wonders; who divided the waters of the Red sea before you, and who appeared in awful majesty at Mount Sinai; that God whom you are commanded to worship, and whose laws you are bound to obey—is the Great Being who reared that wonderful fabric of heaven and earth which your eyes behold.

The *period* when this astonishing effect was produced is also here declared, "*In the beginning.*" Upon a proper conception of the meaning of this expression depends, in a great measure, the reconciliation of the geological and the Mosaic chronology. The phrase here stated, "In the beginning," is used to denote the commencement of an era, or of a series of successive events. It evi-

dently implies that, at what period soever in the long lapse of past duration, any part of the material creation was brought into existence, it derived that existence from the Self-existent and Eternal Divinity. But no specific period is here stated. Had Moses expressly told his readers that this period, when the first materials of creation were brought into existence, was about 2500 years from the time in which he wrote, then there would have been an almost insuperable difficulty in reconciling the discoveries of geology with such a statement. But no such assertion, either directly or by implication, is to be found throughout the whole range of Divine revelation. Ten thousands of years, or even millions of ages, may have elapsed since the first portions of matter were created, or previous to what is termed the first day's work, in the arrangements of our globe,—for anything that the Scripture asserts to the contrary. No limit is fixed to the time which may have elapsed between the period when the component materials of our globe were created, and the period when it began to be reduced into the order in which we now behold it; and no information is given as to the events which may have occurred during this interval. For it appears to have been the chief design of the Sacred Historian to give a narration of those events which were introductory to the placing of man upon the earth. And in this point of view it is important to remark, that the passage before us is entirely independent of the narrative of the six days' work which follows, and is to be considered simply as a general and most important truth, forming an appropriate introduction both to the following narrative and to the whole system of Revelation.

It is therefore to be regretted that certain theologians should still persist in maintaining that the whole material creation must be limited to a period within 6000 years from this date, when Scripture is silent on this point; for in so doing they put an argument into the hands of the philosophical infidel, which it is in his power to wield against the truth and authority of Revelation.

If the propriety of the explanation now given be admitted, then it completely removes every objection against the Mosaic record, derived from the supposed antiquity of the earth. Although it could be proved that some of the strata of our globe were formed millions of ages ago; although we should conceive what is neither impossible, nor altogether improbable—that our globe, in another form, has been the abode, for thousands of ages, of intellectual beings analogous to man, who are now transported to another region of creation—or that it has been the habitation of numerous and diversified races both of sentient and intellectual natures, and that millions of millions of ages have rolled on since the Creator put forth his Omnipotent energy, and since such stupendous revolutions commenced—neither of such views is in the least discordant with any doctrine or fact recorded in the sacred oracles. The Psalmist declares in reference to creation, when addressing the Almighty, "Of old hast thou laid the foundations of the earth, and the heavens are the works of thy hands;" and the Apostle Paul declares, "Thou Lord, IN THE BEGINNING, hast laid the foundations of the earth." But no specific period is stated here, or in any other portion of Scripture; and the expression of OLD is not only correspondent with what we have now stated, but seems to imply the idea of the high antiquity of the earth.

The circumstance now adverted to—that Moses specifies no definite period as the commencement

of the material creation—I consider as a corroborative argument for the truth of Divine Revelation. Had he written at random, or from vague tradition, or had he intended merely to give play to an exuberant fancy, in describing what no uninspired mortal could ever have known—it is not likely he would have used language so cautious and appropriate, as not to have interfered with any subsequent discoveries that might be made in the constitution of the material universe. Among all the cosmogonies which have been composed by heathen writers, either from tradition or from their own fancies, there is not one which accords with the discoveries of modern times; but, on the contrary, they all contain statements in direct opposition to facts which are known to exist in the material system. But the inspired writers were—perhaps unconsciously to themselves—directed to use such language as, when rightly interpreted, would be quite consistent with all the views and discoveries that might be opened of the works of God to the latest generations.

It has been supposed by some who cannot be persuaded to admit the notion of the high antiquity of the earth, that the rocks, with all the fossil petrifications they contain, were created just as we find them, in a moment of time. “The Divine Being,” they affirm, “might as easily have made matter to assume the form of a shell, a fish, a lizard, or a water-worn pebble, such as we find in these rocks, or of any other shape or structure.” To all who have bestowed the least attention on the strata of the earth and their fossil remains, such statements and reasonings must appear foolish and absurd in the highest degree. To use the words of Professor Silliman: “We will not inquire whether Almighty Power inserted plants and animals in mineral masses, and was thus exerted in working a long series of useless miracles without design or end, and therefore incredible. The man who can believe, for example, that the *Iguanodon*, with his gigantic form, 70 feet in length, 10 in height, and 15 in girth, was created in the midst of consolidated sandstone, and placed down 1000 or 1200 feet from the surface of the earth, in a rock composed of ruins and fragments, and containing vegetables, shells, fish, and rolled pebbles—such a man can believe anything, with or without evidence. If there be any such persons, we must leave them to their own reflections, since they cannot be influenced by reason and sound argument; with them we can sustain no discussion, for there is no common ground on which we can meet.”

But why, I would ask, should the idea of the high antiquity of the earth frighten any persons from acquiescing in it, when it is not in the least repugnant to the declarations of Scripture? So far from contracting or distorting our views of the Divine perfections, it tends to expand our conceptions of the plans and operations of the Deity. If periods of duration almost too great for human powers to estimate, have been employed since the original creation of our globe, to bring it to its present state,—if vast successive revolutions, at different eras, have taken place upon its surface—if the waters of the mighty deep have at different periods overflowed the solid land—if the place where we now stand was once a portion of the bottom of the ocean, over which its mighty billows for ages had rolled—if subterraneous fires have at different periods raised up from the bottom of the deep those huge mountains which now lift their summits to the clouds—if lofty mountains have been sunk down many thousand feet below their ancient level, so as to form deep valleys of

the bottom of the seas—if the Almighty, after creating the matter of our globe, impressed certain laws upon its elementary substances, and left these laws to operate as they now do, with only occasional interferences—if races of animated beings have occupied the globe for myriads of ages—if new races have been created at different periods and subsequently destroyed—or if numerous orders of intelligent existence may have occupied the surface of the globe ages before man was introduced to this terrestrial scene—if tremendous convulsions have shaken the firm foundations of the earth—in short, if by all the processes to which we have alluded, our globe was gradually prepared for the purposes it now fulfills, and that the Creator chose to employ these rather than the special interposition of miraculous power—such considerations tend to exhibit the power, wisdom, and benevolence of the Deity, in a new point of view, and to enlarge our conceptions of the magnificent plans of him who is “The King eternal, immortal, and invisible,” who is “wonderful in counsel and excellent in working.” We are here shown that the space which has intervened between the present time and the period when man was first placed upon the globe, is but one of the units of a vast series of chronological periods which have gone before, and which stretch backward into the abyss of immeasurable duration. It is but a single link of the great chain which stretches from the moment when matter first arose from nothing, to diversify the wilds of immensity, down to the hour which is now passing over us. And who knows but that the system of the globe with which we are presently connected may be but one link in an interminable series of events connected with other orders of intelligences, which will be unfolded during the revolutions of a coming eternity.

The science of astronomy directs our views to regions of space which are immeasurable by mortals, and perhaps even by intelligences of a higher order, and discloses to our sight ten thousands and millions of magnificent orbs, whose existence was not even suspected 200 years ago. Geology directs our views to a stupendous series of events stretching back to the ages of a past eternity. The one conducts our vision to the far distant regions of immensity;—the other to the immeasurable periods of past duration; the one enlarges our conceptions of *space*, and the innumerable objects with which it is diversified;—the other expands our ideas of *time*, and the revolutions which have marked its progress. But astronomy has done more than this. Like Geology, it extends our views to periods of time immensely long in the flux of past duration—periods during which thousands of the luminaries of heaven have existed and displayed their radiance. Sir W. Herschel, in his remarks on the *Nebulae*, has concluded, from a variety of ingenious reasonings and observations, that these nebulae which assume a milky light or appearance, cannot be less than about 7000 times the distance of the star *Sirius*, or 163 thousand *billions* of miles; and from other observations, it is inferred that other bodies in the heavens are removed to a *much greater* distance. Now, light, notwithstanding its amazing velocity of 192,000 miles in a second, would be nearly *thirty thousand years* ere it could fly from such a nebulae to the earth. Since, therefore, it is a fact that the light of such bodies has actually been seen, and consequently, that it must have been traveling at least many thousands of years before it could have reached the eyes of any of the inhabitants of our globe; it follows, that such bodies



must have been brought into existence at far distant periods of past duration, otherwise they could not thus have darted their light through such vast spaces of immensity.

The discoveries of modern astronomy likewise disclose to us certain facts which lead us to the conclusion, that certain progressive operations are going forward, analogous to those which appear to have been carried forward in remote ages, in relation to our globe.—Had our limits permitted, we might have shown that some of the comets appear to be in an early stage of their progress toward becoming habitable worlds—that many of the nebulae give evidence of a gradual progression toward condensation—that the appearance of new stars, the disappearance of others which had long shone in the heavens, and the gradual diminution of the light of others—the changes which appear to be occasionally taking place on the surfaces of the sun and the planets, along with other celestial phenomena—are indications that progression toward perfection, and perpetual change, are not peculiar to our world, but are principles in the Creator's government pervading the wide-extended universe.

In short, progressive improvement toward perfection forms a characteristic of the plans of the Almighty, not only in the physical, but also in the moral world. In the first instance, after the flood, the knowledge of the true God was chiefly confined to the family of Abraham; afterward, it was disseminated among the tribes of Israel, but circumscribed within the small territory of Judea; in process of time it was partially diffused among the surrounding nations; after the Christian era it spread abroad through the greater part of the Roman Empire; it has now extended its influence over most of the European nations, and over a certain portion of the tribes that inhabit Asia, Africa, and America. It is still in progress; and, on the foundation of the declarations of inspired prophets, we now look forward to the period when "the glory of Jehovah shall be revealed, and when all flesh shall see it together;" when "all the ends of the world shall remember and turn to the Lord," and "when righteousness and praise shall spring forth before all nations." And the scenes of a coming eternity will doubtless display changes and revolutions far surpassing in grandeur all the events which have happened during the myriads of ages which have already passed, and which will excite the astonishment and adoration of an admiring universe.—Even in an intellectual and political point of view, the nations are making progress toward perfection. "Old things are passing away," and new scenes of improvement are gradually unfolding. The state of society, in the island in which we dwell, 2000 years ago, presents nearly as great a contrast to what is now, as the chaotic state of our globe exhibited before it was reduced to the beauty and order in which we now behold it.—In short, everything we contemplate in the scene around us is progressive; the faculties of the human mind, and the corporeal powers from infancy to manhood—the growth of all the animal and vegetable races—the improvements of art, and the discoveries of science—education, civilization, and political economy—the cultivation of the earth, the mode of traveling by sea and land, and hundreds of other objects and movements demonstrate that *progression* is a law which pervades both the intellectual and the corporeal universe;—and, in the future world, the expansion of the human faculties, and the progress of the mind from one scene of material and intellectual grandeur to another, will form one

portion of the happiness of renovated spirits: and as such a progression will never cease, their felicity will be of perpetual duration; for, if a finite spirit were to stop short in its excursions, or to arrive at a boundary where it could proceed no farther—from that moment its happiness would begin to diminish, and misery, to a certain extent, would infallibly ensue.

I have only to add, that whatever may be affirmed respecting the antiquity of the materials of which the earth is composed, it is admitted by every Geologist, that our globe, *as to its present state and arrangement*, has been comparatively of short duration. All the physical monuments which exist, and the progressive changes which have happened in the strata of the earth, as well as historical monuments, and the concurrent tradition of many nations, bear witness to this truth, that the first appearance of man upon the face of the globe cannot be referred to a period farther back than five or six thousand years from the present time.

Had the limits assigned to the present article permitted, I might have introduced some remarks on the 2d verse of the 1st chapter of Genesis, "The earth was without form and void," etc., or as it has sometimes been translated—"Afterward the earth became waste and desolate"—which expressions evidently imply that, at the period here alluded to, the substance or materials of the globe *did exist*; for we are told that the earth "*was*," or "*had become*," desolate or waste, previous to the arrangements which are subsequently described.

How long it had continued in this state, or in any of its previous states—whether a year, a century, or thousands of years, we are not informed, nor is there any expression in scripture which determines this, so that we are left at full liberty to carry our views on this point as far back into the ages of past duration as the facts connected with the structure of our globe may warrant, without controverting any position contained in the Sacred Oracles.—I might likewise have shown that the sun and stars must have been brought into existence *before* the period called the "fourth day," at which time they were appointed "to rule the day, and to be for signs and seasons, and for days and years"—and that the Creator, either through the medium of physical causes, or by a direct interposition of his power, produced the effects described in the Sacred Narrative—such as the separation of the ocean from the dry land—in the periods of time there specified. But the proof and illustration of such positions would occupy too much space in the present work.\*

On the whole, the subject of Geology forms an interesting and instructive study both to the philosopher and to the Christian. When we take a survey of the august objects which diversify the surface of our globe; when we enter the wild and romantic scene of a mountainous country, or descend into the subterraneous regions of the globe, we are everywhere struck with the vestiges of operations carried on by the powers of Nature, upon a scale of prodigious magnitude, and with the exertion of forces, the stupendous nature of which astonishes and overpowers the mind? We seem as if standing on the ruins, and contemplating the vestiges of a former world. We behold

\* For a further illustration of some of these topics, the author respectfully refers the reader to a Lecture, lately published, entitled "Discoveries of Modern Geology not inconsistent with Revelation"—being the 6th of a series of Lectures to Young Men, delivered in Broughton Place Church, Edinburgh, in March, 1842.

"hills" which "have melted like wax at the presence of the Lord," and "mountains" which "have been carried into the midst of the sea." We behold rocks of enormous size, which have been rent from their foundations, and rolled from one continent to another—the most solid strata of the earth bent under the action of some tremendous power, and dispersed in fragments throughout the surrounding regions. We behold the summits of lofty mountains, over which the ocean had rolled its mighty billows—confounding lands and seas in one universal devastation—transporting plants and forests from one quarter of the world to another, and spreading universal destruction among the inhabitants of the waters and the earth. Contemplating such scenes of grandeur, we perceive the force and sublimity of those descriptions of the Deity contained in the volume of inspiration. "The Lord reigneth; he is clothed with majesty; in his hand are the deep places of the earth, the strength of hills is his also. He removeth the mountains and they know not; he overturneth them in his anger; he shaketh the earth out of her place, and the pillars thereof tremble. At his presence the earth shook and trembled; the foundations also of the hills moved and were shaken. He covereth the earth with the deep as with a garment, the waters stood above the mountains. At his rebuke they fled; at the voice of his thunders they hastened away."

But, amidst all the revolutions and catastrophes that have taken place in the constitution of our globe, there is the clearest evidence of an All-wise and superintending Providence directing every event. Amidst the convulsions which have rent its strata—that have "carried hills into the midst of the seas"—and raised mountains from the bottom of the ocean—these are striking indications of Divine Benevolence in preparing our world for the comfort and accommodations its inhabitants now enjoy. The facts disclosed by geological investigation tend to enlarge our conceptions of the attributes of the Divinity, and of the sublimity of his plans and arrangements in the universe; and to demonstrate that his creating power has been repeatedly exercised during countless ages, in calling into existence numerous orders of beings, and in carrying forward his arrangements to a glorious consummation.

#### ASTRONOMY.

Another science which stands in an intimate relation to religion, is Astronomy.

This sublime science teaches us the magnitudes and distances of the heavenly bodies, their arrangement, their various motions and phenomena, and the laws by which their movements are regulated. It presents to our view objects the most wonderful and sublime; whether we consider the *vast magnitude* of the bodies about which it is conversant—their immense *number*—the *velocity* of their motions—the *astounding forces* requisite to impel them in their rapid career through the regions of the sky—the *vast spaces* which surround them, and in which they perform their revolutions—the *magnificent circles* they describe—the *splendor* of their appearance—or the *important ends* they are destined to serve in the grand system of the universe. Having adverted to this subject, when illustrating the Omnipotence of the Deity, I shall here simply state a few additional facts with respect to the general appearance of the heavens, the bodies which compose the planetary system, and the discoveries which have been made in the region of the stars.

When we lift our eyes toward the sky, we per-

ceive an apparent hollow hemisphere, placed at an indefinite distance, and surrounding the earth on every hand. In the day-time, the principal object which appears in this hemisphere is the *sun*. In the morning, we see him rise above the distant mountains, or from the extremity of the ocean; he gradually ascends the vault of heaven, and then declines and disappears in the opposite quarter of the sky. In the northern parts of the globe, where we reside, if, about the 21st of March, we place ourselves on an open plain, with our face toward the south, the sun will appear to rise on our left, or due east, about six in the morning, and about the same hour in the evening he will set due west. In the month of June, he rises to our left, but somewhat behind us, in a direction toward the north-east, ascends to a greater height at noon than in the month of March, and, after describing a large arc of the heavens, sets on our right and still behind us, in the north-western quarter of the sky. In the month of December, if we stand in the same position, we may observe, without turning ourselves, both his rising and setting. He rises in the south-east, ascends to a small elevation at noon, and sets in the south-west, after having described a very small arc of the heavens. Every day he appears to move a little toward the *east*, or contrary to his apparent diurnal motion; for the stars which are seen to the eastward of him, appear every succeeding day to make a nearer approach to the place in which he is seen. All the variety of these successive changes is accomplished within the period of 365 days 6 hours, in which time he appears to have made a complete revolution around the heavens from *west to east*.

The *moon* is the next object in the heavens which naturally attracts our attention; and she is found to go through similar variations in the course of a month. When she first becomes visible at new moon, she appears in the western part of the heavens, in the form of a crescent, not far from the setting sun. Every night she increases in size, and removes to a greater distance from the sun, until at last she appears in the eastern part of the horizon, just as the sun disappears in the western; at which time she presents a round full-enlightened face. After this she gradually moves farther and farther eastward, and her enlightened part gradually decreases, until at last she seems to approach the sun as nearly in the east as she did in the west, and rises only a little before him in the morning, in the form of a crescent. All these different changes may be traced, by attending to her apparent positions, from time to time, with respect to the fixed stars.

A dark shadow is occasionally seen to move across the face of the moon, which obscures her light, and gives her the appearance of tarnished copper. Sometimes this shadow covers only a small portion of her surface; at other times it covers the whole of her disc for an hour or two, and its margin always appears of the figure of a segment of a circle. This phenomenon, which happens, at an average, about twice every year, is termed an *eclipse of the moon*. It is produced by the shadow of the earth falling upon the moon, when the sun, the earth, and the moon are nearly in a straight line; and can happen only at the time of *full moon*. Sometimes the moon appears to pass across the body of the sun; when her dark side is turned toward the earth, covering his disc either in whole or in part, and intercepting his rays from a certain portion of the earth. This is called an *eclipse of the sun*, and can hap-

pen only at the time of *new moon*. In a total eclipse of the sun, which seldom happens, the darkness is so striking, that some of the planets and sometimes the larger stars are seen, and the inferior animals appear struck with terror.

Again, if on a winter's evening, about six o'clock, we direct our view to the eastern quarter of the sky, we shall perceive certain stars just risen above the horizon; if we view the same stars about midnight, we shall find them at a considerable elevation in the south, having apparently moved over a space equal to one-half of the whole hemisphere. On the next morning, about six o'clock, the same stars will be seen setting in the western part of the sky. If we turn our eyes toward the north, we shall perceive a similar motion in these twinkling orbs; but with this difference, that a very considerable number of them neither rise nor set, but seem to move round an immovable point, called the north pole. Near this point is placed the pole star, which seems to have little or no apparent motion, and which, in

our latitude, appears elevated a little more than half way between the northern part of our horizon and the *zenith*, or point above our heads.

The following cut, which represents the principal stars in the constellations *Ursa Major* and *Ursa Minor*, will enable the reader to recognize the Pole star, by attending to the following directions. The seven stars in the lower part of the figure represent *Ursa Major*, or the Great Bear, sometimes known by the names of the *Plow* and *Charles's Wain*. The stars on the upper part represent *Ursa Minor*, or the Little Bear, the largest star of which, on the right hand side, is the Pole star. About the beginning of November, at 6 or 7 o'clock in the evening, the Great Bear will appear near the north, at a low elevation above the horizon, and nearly in the position here represented. The two stars on the right hand side of the Great Bear are called the *Pointers*, and are distant from each other about 5 degrees. If a line connecting these stars be considered as prolonged upward to a considerable distance (about

Fig. 20.

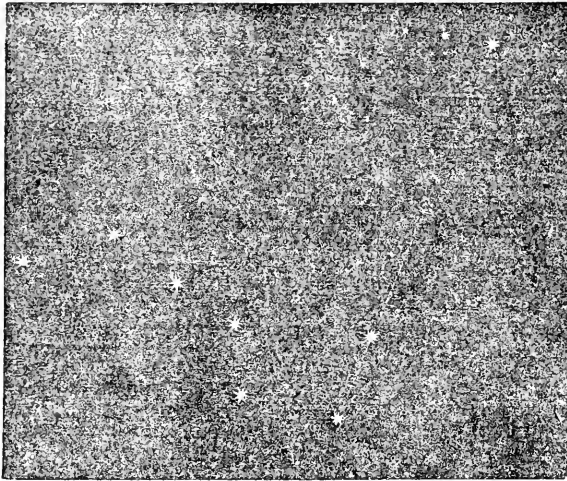

29 degrees), until it meet the first bright star, that star is the *Pole star*, which is here represented at the higher part of the figure. Were the same observation made about the middle of April, at 10 o'clock in the evening, the Great Bear will appear almost directly over our heads, *above* the Pole star, and then we must conceive the line connecting the two *Pointers* as drawn *downward* toward the Pole star. At different times of the night, and at different periods of the year, the Great Bear will appear to be in different positions with respect to the Pole star, sometimes below, sometimes above, and at other times to the east or the west of it. But in all positions, a line drawn through the *Pointers* will always direct the eye to the Pole star.

A person who has directed his attention to the heavens for the first time, after having made such observations, will naturally inquire — Whence come those stars which begin to appear in the east? Whither have those gone which have disappeared in the west? and, What becomes, during the day, of the stars which are seen in the night?—It will soon occur to a rational observer, who is convinced of the roundness of the earth, that the stars which rise above the eastern horizon come from another hemisphere, which we are

apt to imagine below us, and when they set, return to that hemisphere again; and that the reason why the stars are not seen in the day-time, is not because they are absent from our hemisphere, or have ceased to shine, but because their light is obscured by the more vivid splendor of the sun.\*

\* This is not beyond all doubt by the invention of the telescope; by which instrument, adapted to an equatorial motion, we are enabled to see many of the stars even at noon-day. The author of this work, in 1812 and 1813, made a number of observations by means of an *Equatorial Telescope*, to determine the following particulars:—What stars and planets may be conveniently seen in the day-time, when the sun is above the horizon?—what degrees of magnifying power are requisite for distinguishing them?—how near their conjunction with the sun they may be seen?—and, whether the diminution of the aperture of the telescope, or the increase of magnifying power, conduces most to render a star or planet visible in day-light? The results of several hundreds of observations on these points, accompanied with some original calculations and remarks, are inserted in Nicholson's *Philosophical Journal*, for October 1812, vol. xxxv, pp. 100-128. The following are some of the results which were deduced from the observations:—That a star of the *first* magnitude may be distinguished, at any time of the day, with a magnifying power of 30 times, but that a higher magnifying power is preferable.—That most of the stars of the second magnitude may be seen with a power of 100; and with a power of 60 times, when the sun is not much more than two hours above the horizon.—That the planet Jupiter,

From such observations we are led to conclude, that the globe on which we tread is suspended in empty space—is surrounded on all sides by the celestial vault—and that the whole sphere of the heavens has an *apparent* motion round the earth every twenty-four hours. Whether this motion be real, or only apparent, must be determined by other considerations.

Such general views of the nocturnal heavens, which every common observer may take, have a tendency to expand the mind, and to elevate it to the contemplation of an Invisible Power, by which such mighty movements are conducted. Whether we consider the vast concave, with all its radiant orbs, moving in majestic grandeur around our globe, or the earth itself whirling round its inhabitants in an opposite direction—an idea of sublimity, and of almighty energy, irresistibly forces itself upon the mind, which throws completely into the shade the mightiest efforts of human power. The most powerful mechanical engines that were ever constructed by the agency of man can scarcely afford us the least assistance in forming a conception of that incomprehensible Power, which, with unceasing energy, communicates motion to revolving worlds. And yet, such is the apathy with which the heavens are viewed by the greater part of mankind, that there are thousands who have occasionally gazed at the stars for the space of fifty years, who are still ignorant of the fact, that they perform an *apparent* diurnal revolution round our globe.

Again, if we contemplate the heavens with some attention, for a number of successive nights, we shall find, that by far the greater part of the stars never vary their positions with respect to each other. If we observe two stars at a certain apparent distance from each other, either north or south, or in any other direction, they will appear at the same distance, and in the same relative position to each other, the next evening, the next month, and the next year. The stars, for instance, which form the *sword* and *belt* of *Orion*, present to our eye the same figure and relative aspect, during the whole period they are visible in winter, and from one year to another; and the same is the case with all the fixed stars in the firmament. On examining the sky a little more minutely, however, we perceive certain bodies which regularly shift their positions. Sometimes

they appear to move toward the east, sometimes toward the west, and at other times seem to remain in a stationary position. These bodies have obtained the name of *planets*, or wandering stars; and in our latitude are most frequently seen, either in the eastern and western, or in the southern parts of the heavens. Ten of these planetary orbs have been discovered: six of which are, for the most part, invisible to the naked eye. By a careful examination of the motions of these bodies, and their different aspects, astronomers have determined that they all move round the sun as the center of their motions, and form, along with the earth and several smaller globes, one grand and harmonious system. This assemblage of planetary bodies, is generally termed the Solar system, of which I shall now exhibit a brief outline.

#### THE SOLAR SYSTEM.

Of this system, the SUN is the center and the animating principle, and by far the largest body that exists within its limits. The first thing that strikes the mind when contemplating this glorious orb, is its astonishing magnitude. This vast globe is found to be about 880,000 miles in diameter, and consequently contains a mass of matter equal to *thirteen hundred thousand globes* of the size of the earth. Were its central parts placed adjacent to the surface of the earth, its circumference would reach two hundred thousand miles beyond the moon's orbit, on every side, filling a cubical space of 356,818,739,200,000,000 miles. If it would require 18,000 years to traverse every square mile on the earth's surface, at the rate of 30 miles a-day,\* it would require more than *two hundred millions of years* to pass over every portion of the sun's surface, at the same rate. Even at the rate of 90 miles a-day, it would require more than 80 years to go round its circumference. Of a body so vast in its dimensions, the human mind, with all its efforts, can form no adequate conception. It appears an extensive universe in itself; and although no other body existed within the range of infinite space, this globe alone would afford a powerful demonstration of the Omnipotence of the Creator. Were the sun a hollow sphere, surrounded by an external shell and a luminous atmosphere; were this shell perforated with several hundreds of openings into the internal parts; were a globe as large as the earth placed at its center, and another globe as large as the moon, and at the same distance from the center as the moon is from us, to revolve round the central globe,—it would present to the view a universe as splendid and glorious as that which now appears to the vulgar eye—a universe as large and extensive as the whole creation was conceived to be by our ancestors, in the infancy of astronomy. And who can tell, but that the Almighty Being, who has not left a drop of water in a stagnant pool without its inhabitants, has arranged a number of worlds within the capacious circuit of the sun, and peopled them with intelligent beings in the first stages of their existence, to remain there for a certain period, until they be prepared for being transported to a more expansive sphere of existence? It is easy to conceive that enjoyments as exquisite, and a range of thought as ample, as have ever yet been experienced by the majority of the inhabitants of our world, might be afforded to myriads of beings thus placed at the center of this magnificent luminary. This supposition is

when not within 30 or 40 degrees of the sun, may be seen with a power of 15 times; and that Venus may, in most instances, be seen with a power of from 7 to 100 times, and upward.—That Jupiter can scarcely be distinguished in the day-time, when within 25 degrees of the sun; but that Venus may be distinctly perceived near her superior conjunction, when only 1 degree and 27 minutes from the sun's margin; and consequently may be visible at the time of that conjunction, when her geocentric latitude equals or exceeds 1 degree 43 minutes.—That she may be perceived like a fine slender crescent, within 35 hours after passing her inferior conjunction, etc. One practical purpose to which such observations on Venus, at the time of her superior conjunction, may be applied, is to determine the difference (if any) between her polar and equatorial diameters. For it is only at that conjunction that she presents to the earth a full enlightened hemisphere; and in no other position can the measure of both diameters be taken, except when she makes a transit across the sun's disc. As the earth, Mars, Jupiter, and Saturn, are found to be spheroids, it is highly probable that Venus is of a similar figure; but this point has never yet been ascertained by actual observation. See also the Edinburgh Philosophical Journal, No. V, for July 1820, p. 191; and No. XIII, for July 1822.—The Scots' Magazine, for Feb. 1814, p. 84.—Monthly Magazine, Feb. 1814, and August 1820, p. 62.—Brewster's Ferguson's Astronomy, 2d edition, vol. ii, p. 111.—On March 10, 1842, the author saw Venus about 12 o'clock noon, when only 1° 21' distant from the sun's eastern limb, with a 3½ feet achromatic telescope, magnifying 95 times—the aperture of the object glass being constructed to 1½ inches.

\* See p. 18.

at least as probable as that of the celebrated Sir W. Herschel, who supposed that the *exterior* surface of the sun was peopled with inhabitants. For if this were the case, the range of view of these inhabitants would be confined within the limits of two or three hundred miles, and no celestial body, but an immense blaze of light would be visible in their hemisphere. Such is the variety which appears among the works of God, and such is the diversity of situations in which sensitive beings are placed, that we dare not pronounce it impossible that both these suppositions may be realized.

Though the sun seems to perform a daily circuit around our globe, he may be said, in this respect, to be fixed and immovable. This motion is not *real*, but only *apparent*, and is owing to the globe on which we are placed moving round its axis from west to east; just as the objects on the bank of a river seem to move in a contrary direction, when we are sailing along its stream in a steambat. The only motion which is found to exist in the sun is a motion of *rotation*, like that of a globe or ball twirled round a pivot or axis, which is performed in the space of twenty-five days and ten hours. This motion has been ascertained by means of a variety of dark spots which are discovered by the telescope on the sun's disc; which first appear on his eastern limb, and after a period of about thirteen days, disappear on his western, and after a similar period reappear on his eastern edge. These spots are various, both in number, in magnitude, and in shape: sometimes forty or fifty, and sometimes only one or two, are visible, and at other times the sun appears entirely without spots. Most of them have a very dark nucleus, or central part, surrounded by an umbra, or fainter shade. Some of the spots are as large as would cover the whole continent of Europe, Asia, and Africa, others have been observed of the size of the whole surface of the earth; and one was seen, in the year 1779, which was computed to be more than *fifty thousand miles* in diameter.

With regard to the nature of this globe—it appears highly probable, from the observations of Sir W. Herschel, that the sun is a solid and opaque body, surrounded with luminous clouds which float in the solar atmosphere, and that the dark nucleus of the spots is the opaque body of the sun appearing through occasional openings in this atmosphere. The light of the atmosphere he computes to be not less than 1843, nor more than 2755 miles, consisting of two regions; that nearest the sun being opaque, and probably resembling the clouds of our earth: the outermost emitting vast quantities of light, and forming the apparent luminous globe we behold.

The sun is the grand source of light and heat, both to the earth and to all the other planetary bodies. The heat he diffuses animates every part of our sublunary system, and all that variety of coloring which adorns the terrestrial landscape is produced by his rays. It has been lately discovered that the rays of light and the rays of heat, or *caloric*, are distinct from each other; for it can be demonstrated, that some rays from the sun produce heat, which have no power of communicating light or color. The greatest heat is found in the *red* rays, the least in the *violet* rays; and in a space beyond the red rays, where there is no light, the temperature is greatest. The rays of the sun have also been found to produce different chemical effects. The white muriate of silver is blackened in the violet ray in the space of fifteen seconds, though the red will not produce the same effect in less than twenty minutes. Phosphorus is kindled in the vicinity of the red ray, and ex-

tinguished in the vicinity of the violet. The solar light, therefore, consists of *three* different orders of rays, one producing *color*, a second producing *heat*, and a third *chemical* effects. Euler has computed that the light of the sun is equal to 6500 candles at a foot distance, while the moon would be as one candle at 7½ feet; Venus at 421 feet; and Jupiter at 1320 feet.—That this immense luminary appears so small to our eyes is owing to its vast distance, which is no less than ninety-five millions of miles. Some faint idea of this distance may be obtained, by considering that a steambat, moving at the rate of 200 miles a-day, would require *thirteen hundred years* before it could traverse the space which intervenes between us and the sun.

“Hail, sacred source of inexhausted light!  
Prodigious instance of creating might.  
His distance man's imagination fails;  
Numbers will scarce avail to count the miles,  
As swift as thought he darts his radiance round  
To distant worlds, his system's utmost bound.”

The planet *MERCURY*.—Mercury is the nearest planet to the sun that has yet been discovered.—He is about 37 millions of miles distant from the sun, and revolves around him in 88 days. His diameter is about 3200 miles. Before the discovery of the four new planets, Ceres, Pallas, Juno, and Vesta, in the beginning of the present century, this globe was considered as the smallest primary planet in the system. His surface, however, contains above 32 millions of square miles, which is not much less than all the habitable parts of our globe. On account of his nearness to the sun he is seldom seen by the naked eye; being always near that quarter of the heavens where the sun appears; and therefore few discoveries have been made on his surface by the telescope. M. Schroeter concludes, from certain observations, that this planet revolves round its axis in twenty-four hours and five minutes. The sun will appear to an inhabitant of Mercury seven times larger than to an inhabitant of the earth: and if the degree of heat be in proportion to a planet's nearness to the sun, the heat in this planet will be seven times greater than on the surface of our globe; and consequently, were the earth placed in the same position, all the water on its surface would boil, and soon be turned into vapor. But the All-wise Creator has doubtless attempered the surface of that globe, and the constitution of the beings that may occupy it, to the situation in which they are placed.\*

*VENUS*, the next planet in order from the sun,

\* From a variety of facts which have been observed in relation to the production of *Caloric*, it does not appear probable that the degree of heat on the surfaces of the different planets is inversely proportional to the squares of their respective distances from the sun. It is more probable that it depends chiefly on the distribution of the *substance of caloric* on the surfaces and throughout the atmospheres of these bodies—in different quantities, according to the different situations they occupy in the Solar system; and that these different quantities of caloric are put into action by the influence of the solar rays, so as to produce that degree of *sensible* heat requisite for each respective planetary globe. On this hypothesis—which is corroborated by a great variety of facts and experiments—there may be no more sensible heat felt on the surface of the planet Mercury than on the surface of Uranus, although one of these bodies is nearly 50 times nearer the sun than the other. We have only to suppose that a small quantity of caloric exists in Mercury and a larger quantity in Uranus, proportionate to the distance from the center of the system. On this ground, we have no reason to believe either that the planets nearest the sun are parched with excessive heat, or that those that are most distant are exposed to all the rigors of insufferable cold, or that the different degrees of temperature which may be found in these bodies render them unfit for being the abodes of sensitive and intellectual beings.

revolves around him in 224 days, at the distance of 68 millions of miles: its diameter is about seven thousand seven hundred miles, or nearly the size of the earth; and it turns round its axis in the space of 23 hours and 20 minutes. This planet is the most brilliant orb which appears in our nocturnal heavens, and is usually distinguished by the name of the morning and evening star.—When it approaches nearest to the earth, it is about 27 millions of miles distant; and, at its greatest distance, it is no less than 163 millions of miles from the earth. Were the whole of its enlightened surface turned toward the earth when it is nearest, it would exhibit a light and brilliancy twenty-five times greater than it generally does, and appear like a small brilliant moon; but at that time its dark hemisphere is turned toward our globe. Both Venus and Mercury, when viewed by a telescope, appear to pass successively through all the shapes and appearances of the moon; sometimes assuming a gibbous phase, and at other times the form of a half moon, or that of a crescent; which proves that they are dark bodies in themselves, and derive their light from the sun. The most distinct and beautiful views of Venus, especially when it appears as a crescent, are to be obtained in the *day-time*, by means of an equatorial telescope.—From a variety of observations which the author has made with this instrument, it has been found that Venus may be seen every clear day, without interruption, during a period of 583 days, with the occasional exception of thirteen days in one case and only three days in another—circumstances which cannot be affirmed of any other celestial body, the sun only excepted.\* M. Schroeter attests that he has discovered mountains on the surface of this globe, one of which is 10, another 11, and a third 22 miles high. It appears also to be encompassed with an atmosphere, the densest part of which is about 16,000 feet high. About twice in the course of a century this planet appears to pass, like a dark spot, across the sun's disc. This is termed the *transit* of Venus. The last transit happened June 3, 1769; the next will happen on December 8, 1874, which will be invisible in Europe. Another will happen on the 6th December, 1882, which will be partly visible in Great Britain.

The *Earth* is the next planet in the system.—It moves round the sun in 365 days 5 hours and

49 minutes, at the distance of 95 millions of miles, and round its axis in 23 hours 56 minutes 4 seconds. The former is called its *annual*, and the latter its *diurnal* motion. That the earth is, in reality, a moving body, is a fact which can no longer be called in question; it is indeed susceptible of the clearest demonstration. But my limits will not permit to enter into a detail of the arguments by which it is supported. I have already adverted to one consideration, from which its diurnal rotation may be inferred.\* Either the earth moves round its axis every day, or the *whole universe* moves round it in the same time. To suppose the latter case to be the fact would involve a reflection on the wisdom of its Almighty Author, and would form the only exception that we know to that beautiful proportion, harmony, and simplicity, which appear in all the works of Nature. Were it possible to construct a machine as large as the city of London, and apply to it mechanical powers sufficient to make it revolve on an axis, so as to carry round a furnace for the purpose of roasting a joint of mutton, suspended in the center of its motion—while we might admire the ingenuity and the energies displayed in its construction—all mankind would unite in condemning it as a display of consummate folly. But such an extravagant piece of machinery would not be half so preposterous as to suppose, that the vast universe is daily revolving around our little globe, and that all the planetary motions have an immediate respect to it. And shall we dare ascribe to Him who is “the only wise God,” contrivances which we would pronounce to be the perfection of folly in mankind? It is recorded of the astronomer Alphonsus, king of Castile, who lived in the 13th century, that, after having studied the Ptolemaic system, which supposes the earth at rest in the center of the universe, he uttered the following *impious* sentence: “If I had been of God’s privy council when he made the world, I would have advised him better.” So that false conceptions of the System of Nature lead to erroneous notions of that adorable Being who is possessed of Infinite Perfection.—We find that bodies much larger than the earth have a similar rotation. The planet Jupiter, a globe 295,000 miles in circumference, moves round its axis in less than ten hours; and all the other planetary bodies, on which spots have been discovered, are found to have a diurnal motion. Beside, it is found to be a universal law of nature, that smaller globes revolve around larger; but there is no example in the universe, of a larger body revolving around a smaller. The moon revolves around the earth, but she is much smaller than the earth; the moons which move around Jupiter, Saturn, and Herschel, are all less than their primaries, and the planets which perform their revolutions around the sun are much less than that central luminary.

With regard to the *annual* revolution of the earth,—if such a motion did not exist, the planetary system would present a scene of inextricable confusion. The planets would sometimes move backward, sometimes forward, and at other times remain stationary; and would describe looped curves, so anomalous and confused, that no man in his senses could view the All-wise Creator as the author of so much confusion. But by considering the earth as revolving in an orbit between Venus and Mars (which all celestial observations completely demonstrate), all the apparent irregularities of the planetary motions are completely

\* See Edin. Phil. Journ., No. V, July 1820, and No. XIII, July 1822.—I have found from observation that this planet may be seen in the day-time, when only 1° 21' from the sun’s center; and consequently, when its geocentric latitude at the time of the superior conjunction exceeds that quantity, it may be distinctly seen during the whole period of 583 days, excepting about 25 hours before and after its *inferior* conjunction.—It is well known to astronomers that there has been a difference of opinion with respect to the *period* of the rotation of this planet. Cassini, from observations on a bright spot which advanced 20 degrees in 24 hours 34 minutes, determined the time of its rotation to be 23 hours and 20 minutes. On the other hand, Bianchini, from similar observations, concluded that its diurnal period was 24 days and 8 hours. The difficulty of deciding between these two opinions arises from the short time in which observations can be made in this planet, either before sunrise or after sunset, which prevents us from tracing with accuracy the progressive motion of its spots for a sufficient length of time. And although an observer should mark the position of the spots, at the same hour, on two succeeding evenings, and find they had moved forward about 20 degrees in 24 hours, he would still be at a loss to determine whether they had moved 20 degrees in *all*, since the preceding observation, or had finished a revolution, and 20 degrees more.—In Nicholson’s Philosophical Journal, vol. xxxvi, I endeavored to show how this point may be determined by observations made on Venus in the day-time, by which, in certain cases, the progressive motion of its spots might be traced, without interruption for 12 hours or more, which would completely settle the period of rotation.

solved and accounted for; and the Solar System presents a scene of beauty, harmony, and grandeur, combined with a simplicity of design, which characterizes all the works of Omnipotence.

The Moon.—Next to the sun, the moon is to us the most interesting of all the celestial orbs.—She is the constant attendant of the earth, and revolves around it in 27 days 8 hours; but the period from one new or full moon to another, is about 29 days 12 hours. She is the nearest of all the heavenly bodies; being only about two hundred and forty thousand miles distant from the earth. She is much smaller than the earth; being only 2180 miles in diameter. Her surface, when viewed with a telescope, presents an interesting and a variegated aspect; being diversified with mountains, valleys, rocks, and plains, in every variety of form and position. Some of these mountains form long and elevated ridges, resembling the chains of the Alps and the Andes; while others, of a conical form, rise to a great height, from the middle of level plains, somewhat resembling the Peak of Teneriffe. But the most singular feature of the moon is, those circular ridges and cavities which diversify every portion of her surface. A range of mountains of a circular form, rising three or four miles above the level of the adjacent districts, surrounds, like a mighty rampart, an extensive plain; and, in the middle of this plain or cavity, an insulated conical hill rises to a considerable elevation. Several hundreds of these circular plains, most of which are considerably below the level of the surrounding country, may be perceived with a good telescope, on every region of the lunar surface. They are of all dimensions, from two or three miles to forty miles in diameter; and, if they be adorned with verdure, they must present to the view of a spectator, placed among them, a more variegated, romantic, and sublime scenery than is to be found on the surface of our globe. An idea of some of these scenes may be acquired, by conceiving a plain of about a hundred miles in circumference, encircled with a range of mountains, of various forms, three miles in perpendicular height, and having a mountain near the center, whose top reaches a mile and a half above the level of the plain. From the top of this central mountain, the whole plain, with all its variety of objects, would be distinctly visible; and the view would appear to be bounded on all sides by a lofty amphitheater of mountains, in every diversity of shape, rearing their summits to the sky. From the summit of the circular ridge, the conical hill in the center, the opposite circular range, the plain below, and some of the adjacent plains, which encompass the *exterior* ridge of the mountains, would form another variety of view;—and a third variety would be obtained from the various aspects of the central mountain, and the surrounding scenery as viewed from the plains below.

The lunar mountains are of all sizes, from a furlong to five miles in perpendicular elevation. Certain luminous spots, which have been occasionally seen on the dark side of the moon, seem to demonstrate that fire exists in this planet. Sir W. Herschel, and several other astronomers, suppose that they are volcanoes in a state of eruption. It would be a more pleasing idea, and perhaps as nearly corresponding to fact, to suppose, that these phenomena are owing to some occasional splendid illuminations produced by the lunar inhabitants, during their long nights. Such a scene as the burning of Moscow, the conflagration of an extensive forest, or the splendid illumination

of a large city with gas-light, might present similar appearances to a spectator in the moon.—The bright spots on the moon are the mountainous regions: the dark spots are the plains, or more level parts of the surface. There may probably be rivers or small lakes on this planet; but there are no seas or large collections of water. It appears highly probable, from the observations of Schroeter, that the moon is encompassed with an atmosphere: but no clouds, rain; or snow, seem to exist in it. The illuminating power of the light derived from the moon, according to the experiments made by professor Leslie, is about the *one hundred and fifty thousandth part* of the illuminating power of the sun. According to the experiments of M. Bouguer, it is only as 1 to 500,000.

The moon always presents the same face to us, which proves, that she revolves round her axis in the same time that she revolves round the earth. As this orb derives its light from the sun, and reflects a portion of it upon the earth, so the earth performs the same office to the moon. A spectator on the lunar surface would behold the earth like a luminous orb suspended in the vault of heaven, presenting a surface about 13 times larger than the moon does to us, and appearing sometimes gibbous, sometimes horned, and at other times with a round full face. The light which the earth reflects upon the dark side of the moon may be distinctly perceived by a common telescope, from two to six or eight days after the change.—The lunar surface contains about 15 millions of square miles, and is, therefore, capable of containing a population equal to that of our globe, allowing only about 53 inhabitants to every square mile. That this planet is inhabited by sensitive and intelligent beings, there is every reason to conclude, from a consideration of the sublime scenery with which its surface is adorned, and of the general beneficence of the Creator, who appears to have left no large portion of his material creation without animated existences; and it is highly probable, that *direct proofs* of the moon's being inhabited may hereafter be obtained, when all the varieties on her surface shall have been more minutely explored.\*

The planet Mars.—Next to the earth and moon, the planet Mars performs his revolution round the sun, in one year and ten months, at the distance of 145 millions of miles. His diameter is about 4200 miles, and he is distinguished from all the other planets by his *ruddy* appearance, which is owing to a *dense atmosphere* with which he is environed. With a good telescope, his surface appears diversified with a variety of spots; by the motion of which it is found, that he turns round his axis in 24 hours and 40 minutes. The inclination of his axis to the plane of his orbit being about  $28^{\circ} 42'$ , the days and nights, and the different seasons in this planet, will bear a considerable resemblance to those we experience in our terrestrial sphere. † At his nearest approach to the earth, his distance from us is about 50 millions of miles; and, at his greatest distance, he is about 240 millions of miles; so that in the former case he appears nearly 25 times larger than in the latter. To a spectator in this planet, our earth will appear alternately, as a morning and evening

\* See Appendix. Note IV.

† The inclination of the earth's axis to the ecliptic, or, in other words, to the plane of its annual orbit is  $23^{\circ} 28'$ , which is the cause of the diversity of seasons, and of the different length of days and nights. Were the axis of the earth perpendicular to its orbit, as is the case with the planet Jupiter, there would be no diversity of seasons.

star, and will exhibit all the phases of the moon, just as Venus does to us, but with a less degree of apparent magnitude and splendor. A luminous zone has been observed about the poles of Mars, which is subject to successive changes. Sir W. Herschel supposes that it is produced by the reflection of the sun's light from his frozen regions, and that the melting of these masses of polar ice is the cause of the variation in its magnitude and appearance. This planet moves, in its orbit, at the rate of fifty-five thousand miles an hour.

**The New Planets.**—Between the orbits of Mars and Jupiter, four planetary bodies have been lately discovered, accompanied with circumstances somewhat different from those of the other bodies which compose our system. They are named *Ceres*, *Pallas*, *Juno*, *Vesta*. The planet *Ceres* was discovered at Palermo, in Sicily, by M. Piazzi, on the first day of the present century. It is of a ruddy color, and appears about the size of a star of the eighth magnitude, and is consequently invisible to the naked eye. It performs its revolution in 4 years and 7 months, at the distance of 263 millions of miles from the sun, and is reckoned by some astronomers to be about 1624 miles in diameter, or about half the diameter of Mercury. It appears to be surrounded with a large dense atmosphere.—Pallas was discovered the following year, namely, on the 28th March, 1802, by Dr. Olbers, of Bremen. It is supposed to be about 2000 miles in diameter, or nearly the size of the moon. It revolves about the sun in 4 years and 7 months, or nearly in the same time as *Ceres*, at the distance of 266 millions of miles; and is surrounded with a nebulosity or atmosphere above 400 miles in height, similar to that of *Ceres*.—The planet *Juno* was discovered on the 1st September, 1804, by Mr. Harding, of Bremen. Its mean distance from the sun is about 253 millions of miles; its revolution is completed in 4 years and 130 days, and its diameter is computed to be about 1425 miles. It is free from the nebulosity which surrounds Pallas, and is distinguished from all the other planets by the great eccentricity of its orbit; being at its least distance from the sun only 189 millions of miles, and at its greatest distance, 316 millions.—*Vesta* was discovered by Dr. Olbers on the 29th March, 1807. It appears like a star of the fifth or sixth magnitude, and may sometimes be distinguished by the naked eye. Its light is more intense and white than any of the other three, and it is not surrounded with any nebulosity. It is distant from the sun about 225 millions of miles, and completes its revolutions in 3 years and 240 days. Its diameter has not yet been accurately ascertained; but from the intensity of its light and other circumstances, it is concluded, that it is not inferior in magnitude to either Pallas or Juno.

These planetary globes present to our view a variety of anomalies and singularities, which appear incompatible with the regularity, proportion, and harmony, which were formerly supposed to characterize the arrangements of the Solar system.—They are bodies much smaller in size than the other planets—they revolve nearly at the same distances from the sun, and perform their revolutions in nearly the same periods—their orbits are much more eccentric, and have a much greater degree of inclination to the ecliptic, than those of the old planets—and, what is altogether singular (except in the case of comets), their orbits cross each other; so that there is a possibility that two of these bodies might happen to interfere, and to strike each other, in the course of their revolu-

tions. The orbit of *Ceres* crosses the orbit of Pallas. *Vesta* may sometimes be at a greater distance from the sun than either *Ceres*, Pallas, or Juno, although its mean distance is less than that of either of them, by several millions of miles; so that the orbit of *Vesta* crosses the orbits of all the other three. From these and other circumstances, it has, with a high degree of probability been concluded,—that these four planets are the fragments of a large celestial body which once revolved between Mars and Jupiter, and which had been burst asunder by some immense irruptive force. This idea seems to have occurred to Dr. Olbers, after he had discovered the planet Pallas, and he imagined that other fragments might possibly exist. He concluded, that, if they all diverged from the same point, “they ought to have two common points of reunion, or two nodes in opposite regions of the heavens, through which all the planetary fragments must sooner or later pass.” One of these nodes he found to be in the constellation Virgo, and the other in the Whale; and it is a remarkable coincidence, that it was in the latter of these regions that the planet Juno was discovered by Mr. Harding. In order to detect the remaining fragments (if any existed), Dr. Olbers examined, three times every year, all the small stars in Virgo and the Whale; and it was actually in the constellation Virgo that he discovered the planet *Vesta*. It is not unlikely that other fragments of a similar description may yet be discovered. Sir D. Brewster attributes the fall of meteoric stones\* to the smaller fragments of these bodies happening to come within the sphere of the earth's attraction. His ingenious reasoning on this subject, and in support of Dr. Olbers' hypothesis above stated, may be seen in *Edin. Encyc.*, vol. ii, p. 611, and in his “supplementary chapters to Ferguson's Astronomy.”

The facts to which I have now adverted seem to unfold a new scene in the history of the dispensations of the Almighty, and to warrant the conclusion, that the earth is not the only globe in the universe which is subject to physical changes and moral revolutions.

**The Planet JUPITER.**—This planet is 490 millions of miles distant from the sun, and performs its annual revolution in nearly twelve of our years, moving at the rate of twenty-nine thousand miles an hour. It is the largest planet in the Solar system, being 89,000 miles in diameter, or about fourteen hundred times larger than the earth. Its motion round its axis is performed in nine hours and fifty-six minutes; and, therefore, the portions of its surface about the equator, move at the rate of 28,000 miles an hour, which is nearly twenty-seven times swifter than the earth's diurnal rotation. The figure of Jupiter is that of an

\* Meteoric stones, or what are generally termed *aerolites*, are stones which sometimes fall from the upper regions of the atmosphere upon the earth. The substance of which they are composed is, for the most part, *metallic*; but the ore of which they consist is not to be found in the same *constituents* or proportions, in any terrestrial substances. Their fall is generally preceded by a luminous appearance, a hissing noise, and a loud explosion; and, when found immediately after their descent, are always hot. Their size differs from small fragments of inconsiderable weight, to the most ponderous masses. Some of the larger portions of these stones have been found to weigh from 24 lbs. to several tons; and they have often descended to the earth with a force sufficient to bury them several feet under the soil. Some have supposed that these bodies are projected from volcanoes in the moon; others, that they proceed from volcanoes on the earth; while others imagine that they are generated in the regions of the atmosphere; but the true cause is probably not yet ascertained. In some instances, these stones have penetrated through the roofs of houses, and proved destructive to the inhabitants.



oblate spheroid, the axis, or diameter, passing through the poles, being about 6000 miles shorter than that passing through the equator. The Earth, Saturn, and Mars, are also spheroids; and it is highly probable that Mercury, Venus, and Herschel, are of a similar figure, though the fact has not yet been ascertained by actual observation. When viewed with a telescope, several spots have been occasionally discovered on the surface of this planet, by the motion of which its rotation was determined.

But what chiefly distinguishes the surface of Jupiter, is several streaky appearances, or dusky stripes, which extend across his disc in lines parallel to his equator. These are generally termed his *Belts*. Three of these belts, or zones, nearly equi-distant from each other, are most frequently observed; but they are not regular or constant in their appearance.\* Sometimes only one is to be seen, sometimes five, and sometimes seven or eight have been visible; and in the latter case, two of them have been known to disappear during the time of observation. On the 28th of May, 1780, Sir W. Herschel perceived "the whole surface of Jupiter covered with small curved belts, or rather lines, that were not continuous across his disc." Though these belts are generally parallel to each other, yet they are not always so. Their breadth is likewise variable; one belt having been observed to grow narrow, while another in its neighborhood has increased in breadth, as if the one had flowed into the other. The time of their continuance is also uncertain; sometimes they remain unchanged for several months, at other times, new belts have been formed in an hour or two. What these belts, or variable appearances are, it is difficult to determine. Some have regarded them as strata of clouds floating in the atmosphere of Jupiter; while

others imagine, that they are the marks of great physical revolutions which are perpetually changing the surface of that planet. The former opinion appears the most probable. But whatever be the nature of these belts, the sudden changes to which they are occasionally subject, seem to indicate the rapid operation of some powerful physical agency; for some of them are more than five thousand miles in breadth; and since they have been known to disappear in the space of an hour or two, or even during the time of a casual observation—agents more powerful than any with which we are acquainted must have produced so extensive an effect.

Jupiter is attended by four satellites, or moons, which present a very beautiful appearance when viewed through a telescope. The first moon, or that nearest the planet, is 230,000 miles distant from its center, and goes round it in  $42\frac{1}{2}$  hours; and will appear from its surface four times larger than our moon does to us. The second moon, being farther distant, will appear about the size of ours; the third, somewhat less; and the fourth which is a million of miles distant from Jupiter, and takes sixteen days to go round him, will appear only about one third the diameter of our moon. These moons suffer frequent eclipses from passing through Jupiter's shadow, in the same way as our moon is eclipsed by passing through the shadow of the earth. By the eclipses of these moons, the motion of light was ascertained; and they are found to be of essential use, in determining the longitude of places on the surface of our globe. This planet, if seen from its nearest moon, will present a surface a thousand times as large as our moon does to us, and will appear in the form of a crescent, a half moon, a gibbous phase, and a full moon, in regular succession, every 42 hours.

Fig. 21.

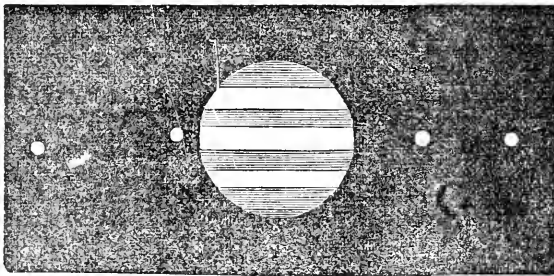

The foregoing figure exhibits a view of Jupiter's belts and satellites as seen through a good telescope; but they do not always appear, two on each side, as here represented, but in every variety of position; and sometimes all on the same side, in the order of their distances; and they seem to move from one side to another, in nearly straight lines, on account of our eye being nearly on a level with the planes of their orbits.

Jupiter's axis being nearly perpendicular to his orbit, he has no sensible change of seasons, such as we experience on the earth. Were we placed on the surface of this planet, with the limited powers of vision we now possess, our earth and moon would entirely disappear, as if they were

\* A representation of these belts in the positions in which they most frequently appear, is exhibited in the Frontispiece, Fig. 2.—Fig. 1 represents the double ring of Saturn as it appears when viewed through a powerful telescope.—Figures 1, 2, 3, 4, etc., represent Saturn, Jupiter, Herschel, the earth, and moon, in their relative sizes and proportions.

blotted out from the map of creation; and the inhabitants of these regions must have much better eyes than ours, if they know that there is in the universe such a globe as the earth.

The Planet SATURN.—This planet is 900 millions of miles distant from the sun, being nearly double the distance of Jupiter. Its diameter is 79,000 miles, and consequently, it is more than nine hundred times the bulk of the earth. It takes it  $29\frac{1}{2}$  years to complete its revolution about the sun; but its diurnal motion is completed in ten hours and sixteen minutes; so that the year in this planet is nearly thirty times the length of ours, while the day is shorter, by more than one-half. The year, therefore, contains about twenty-five thousand one hundred and fifty days, or periods of its diurnal rotation, which is equal to 10,750 of our days. Saturn is of a spheroidal figure, or somewhat of the shape of an orange; his equatorial being more than six thousand miles longer than his polar diameter. His surface, like

that of Jupiter, is diversified with belts and dark spots. Sir W. Herschel, at certain times, perceived five belts on his surface, three of which were dark, and two bright. The dark belts had a yellowish tinge, and generally covered a larger zone of the disc of Saturn than the belts of Jupiter occupy upon his surface. On account of the great distance of this planet from the sun, the light it receives from that luminary is only the *ninetieth part* of what we enjoy; but, by calculation, it is found that this quantity is a thousand times greater than the light which the full moon affords to us. Beside, it is surrounded by no fewer than seven moons, which supply it with light in the absence of the sun. Five of these moons were discovered during the seventeenth century, by Huygens and Cassini; and the sixth and seventh were discovered by Sir W. Herschel, in 1789, soon after his large forty feet reflecting telescope was constructed. These moons, and also those which accompany Jupiter, are estimated to be not much less than the earth in magnitude, and are found, like our moon, to revolve round their axes in the same time in which they revolve about their respective primaries.

**RINGS OF SATURN.**—The most extraordinary circumstance connected with this planet is, the phenomenon of a *double ring*, which surrounds its body, but nowhere touches it, being thirty thousand miles distant from any part of the planet, and is carried along with the planet in its circuit around the sun. This is the most singular and astonishing object in the whole range of the planetary system; no other planet being found envi-

roned with so wonderful an appendage: and the planets which may belong to other systems, being placed beyond the reach of our observations, no idea can be formed of the peculiar apparatus with which any of them may be furnished. This double ring consists of two concentric rings, detached from each other; the innermost of which is nearly three times as broad as the outermost. The outside diameter of the *exterior* ring is 204,000 miles; and consequently, in circumference, will measure *six hundred and forty thousand miles*, or eighty times the diameter of our globe. Its breadth is 7200 miles, or nearly the diameter of the earth. Were four hundred and fifty globes, of the size of the earth, placed close to one another, on a plane, this immense ring would inclose the whole of them, together with all the interstices, or open spaces between the different globes. The outside diameter of the *innermost* ring is 184,000 miles, and its breadth 20,000 miles, or about  $2\frac{1}{2}$  times broader than the diameter of the earth. The dark space, or interval between the two rings, is 2500 miles. The breadth of both the rings, including the dark space between them, is thirty thousand miles, which is equal to the distance of the innermost ring from the body of Saturn.

The following figure represents a view of Saturn and his rings, as they would appear were our eye perpendicular to one of the planes of those rings; but our eye is never so much elevated above either plane as to have the visual ray standing at right angles to it: it is never elevated more than 30 degrees above the planes of the rings

Fig. 22.

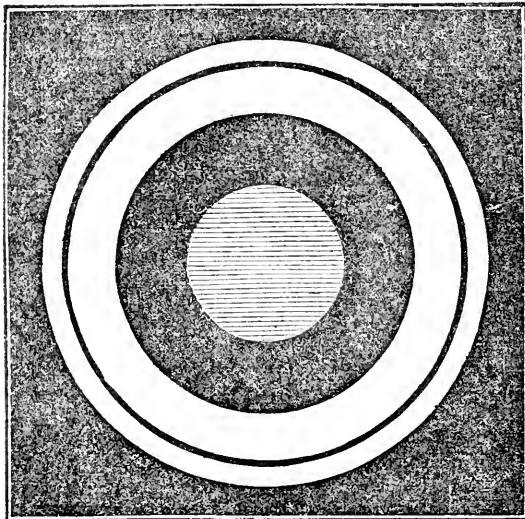

When we view Saturn through a telescope, we always see the ring at an oblique angle, so that it appears of an *oval* form, the outward circular ring being projected into an ellipse more or less oblong, according to the different degrees of obliquity with which it is viewed, as will be seen in the Frontispiece.

These rings cast a deep shadow upon the planet, which proves that they are not shining fluids, but composed of *solid* matter. They appear to be possessed of a higher reflective power than the surface of Saturn: as the light reflected by them is more brilliant than that of the planet.

One obvious use of this double ring is, to reflect light upon the planet in the absence of the sun: in all probability, it also serves as an ample habitation for myriads of sensitive and intelligent beings; for the surfaces of the two rings contain no less than 228 millions of square miles, or about 600 times more than all the habitable parts of our globe, and it is not likely that, in the wise arrangements of the Creator, such an immense space would be left destitute of inhabitants: what other purposes it may be intended to subservise, in the system of Saturn, is at present to us unknown. The sun illuminates one side of it during fifteen

years, or one half of the period of the planet's revolution; and, during the next fifteen years, the other side is enlightened in its turn. Twice in the course of thirty years, there is a short period, during which neither side is enlightened, and when, of course, it ceases to be visible;—namely, at the time when the sun ceases to shine on one side, and is about to shine on the other. It revolves round its axis, and consequently around Saturn, in ten hours and a half, which is at the rate of a thousand miles in a minute, or fifty-eight times swifter than the earth's equator. When viewed from the middle zone of the planet, in the absence of the sun, the rings will appear like vast luminous arches, extending along the canopy of heaven, from the eastern to the western horizon; having an apparent breadth equal to a hundred times the apparent diameter of our moon, and will be seen darkened about the middle, by the shadow of Saturn.\*

There is no other planet in the Solar system, whose firmament will present such a variety of splendid and magnificent objects, as that of Saturn. The various aspects of his seven moons, one rising above the horizon, while another is setting, and a third approaching to the meridian; one entering into an eclipse, and another emerging from it; one appearing as a crescent, and another with a gibbous phase; and sometimes the whole of them shining in the same hemisphere, in one bright assemblage;—the majestic motions of the rings,—at one time illuminating the sky with their splendor, and eclipsing the stars; at another, casting a deep shade over certain regions of the planet, and unveiling to view the wonders of the starry firmament—are scenes worthy of the majesty of the Divine Being to unfold, and of rational creatures to contemplate. Such magnificent displays of Wisdom and Omnipotence, lead us to conclude that the numerous splendid objects connected with this planet, were not created merely to shed their luster on naked rocks and barren sands; but that an immense population of intelligent beings is placed in those regions, to enjoy the bounty and to adore the perfections of their great Creator.

The double ring of Saturn, when viewed through a good telescope, generally appears like a luminous handle on each side of the planet, with a dark interval between the interior edge of the ring, and the convex body of Saturn; which is owing to its oblique position with respect to our line of vision. When its outer edge is turned directly toward the earth, it becomes invisible, or appears like a dark stripe across the disc of the planet as it did in 1832. This phenomenon happens once every fifteen years.

The Planet **HERSCHEL**.—This planet, which is also known by the names of the *Georgium Sidus*, and *Uranus*, was discovered by Sir W. Herschel on the 13th of March, 1781. It is the most distant planet from the sun that has yet been discovered; being removed at no less than 1800

millions of miles from that luminary, which is nineteen times farther than the earth is from the sun—a distance so great, that a cannon ball, flying at the rate of 480 miles an hour, would not reach it in 400 years. Its diameter is about 35,000 miles; and of course, it is about eighty times larger than the earth. It appears like a star of the sixth magnitude; but can seldom be distinguished by the naked eye. It takes about 83 years and a half to complete its revolution round the sun; and, though it is the slowest moving body in the system, it moves at the rate of 15,000 miles an hour. As the degree of sensible heat in any planet does not appear to depend altogether on its nearness to the sun, the temperature of this planet may be as mild as that which obtains in the most genial climate of our globe.\* The diameter of the sun, as seen from Herschel, is little more than the apparent diameter of Venus as seen by the naked eye; and the light which it receives from that luminary, is 360 times less than what we experience; yet this proportion is found by calculation to be equal to the effect which would be produced by 248 of our full moons; and, in the absence of the sun, there are six moons which reflect light upon this distant planet, all of which were discovered likewise by Sir W. Herschel. Small as the proportion of light is which this planet receives from the sun, it is easy to conceive, that beings similar to man, placed on the surface of this globe, with a slight modification of their organs of vision, might be made to perceive objects with a clearness and distinctness even superior to what we can do. We have only to suppose, that the Creator has formed their eyes with *pupils* capable of a much larger expansion than ours; and has indured their *retina* with a much greater degree of nervous sensibility. At all events, we may rest assured, that He who has placed sentient beings in any region, has, by laws with which we are partly unacquainted, adapted the constitution of the inhabitant to the nature of the habitation.

“Strange and amazing must the difference be  
Twixt this dull planet and bright *Mercury!*  
Yet reason says, nor can we doubt at all,  
Millions of beings dwell on either ball,  
With constitutions fitted for that spot  
Where Providence, all-wise, has fixed their lot.”

The celestial globes which I have now described, are all the planets which are at present known to belong to the Solar system. It is probable that other planetary bodies may yet be discovered between the orbits of Saturn and Herschel, and even far beyond the orbit of the latter; and it is also not improbable, that planets may exist in the immense interval of 37 millions of miles between Mercury and the Sun.† These (if any exist) can be detected only by a series of *day observations*, made with equatorial telescopes; as they could not be supposed to be seen, after sunset, on account of their proximity to the sun. Five *primary*; planets, and eight *secondaries*, have been

\* See the Frontispiece, Fig 7, which represents a view of the appearance which the rings and moons of Saturn will exhibit, in certain cases, about midnight, when beheld from a point 20 or 20 degrees north from his equator. The shade on the upper part of the rings represents the shadow of the body of Saturn. This shadow will appear to move gradually to the west as the morning approaches.—From observations which were made some time ago by Captain Kater, Professor Quetelet, and others, it has been surmised that the outer ring of Saturn is divided into several smaller rings. Kater states, that he “saw the outer ring separated by numerous dark divisions extremely close, one stronger than the rest dividing the ring about equally.” Such surmises, however, require to be confirmed by subsequent observations

\* See Note, p. 81.

† The Author, some years ago, described a method by which the planets (if any) within the orbit of Mercury, may be discovered in the day-time, by means of a simple contrivance for intercepting the solar rays, and the frequent application, by a number of observers, of powerful telescopes, to a certain portion of the sky, in the vicinity of the sun. The details of this plan have not yet been published: but the reader will see them alluded to, in No. V. of the Edinburgh Philosophical Journal, for July, 1830, p. 191.

‡ A *primary* planet is that which revolves round the sun as a center; as Mars, Jupiter, and Saturn. A *secondary* planet is one which revolves round a primary planet as its center; as the Moon, and the satellites of Jupiter and

discovered within the last 60 years; and, therefore, we have no reason to conclude, that all the bodies belonging to our system have yet been detected, until every region of the heavens be more fully explored.

**COMETS.**—Beside the planetary globes to which I have now adverted, there is a class of celestial bodies which occasionally appear in the heavens, to which the name of *Comets* has been given. They are distinguished from the other celestial bodies, by their ruddy appearance, and by a long train of light, called the *tail*, which sometimes extends over a considerable portion of the heavens, and which is so transparent that the stars may be seen through it. The tail is always directed to that part of the heavens which is opposite to the sun, and increases in size as it approaches him, and is again gradually diminished, as the comet flies off to the more distant regions of space. Their apparent magnitude is very different: sometimes they appear only of the bigness of the fixed stars; at other times they equal the diameter of Venus; and sometimes they have appeared nearly as large as the Moon. They traverse the heavens in all directions, and cross the orbits of the planets. When examined through a telescope, they appear to consist of a dark central nucleus, surrounded by a dense atmosphere, or mass of vapors. They have been ascertained to move in long narrow *ellipses* or *ovals*, around the sun; some of them, on their nearest approach to him, having been within a million of miles of his center: and then fly off to a region several thousands of millions of miles distant. When near the sun, they move with amazing velocity. The velocity of the comet which appeared in 1680, according to Sir Isaac Newton's calculation, was 880,000 miles an hour. They appear to be bodies of no great density, and their size seldom exceeds that of the moon. The length of the tails of some comets has been estimated at fifty millions of miles. According to Sir W. Herschel's computations, the solid nucleus, or central part of the comet which appeared in 1811, was only 428 miles in diameter; but the real diameter of the head or nebulous portion of the comet, he computed to be about 127,000 miles. The length of its tail he computed to be above one hundred millions of miles, and its breadth nearly fifteen millions. It was nearest to the earth on the 11th October, when its distance was 113 millions of miles. The number of comets which have occasionally been seen within the limits of our system, since the commencement of the Christian era, is about 500, of which the paths or orbits of more than a hundred have been calculated.

As these bodies cross the paths of the planets in every direction, there is a possibility that some of them might strike against the earth in their approach to the sun; and, were this to happen, the consequences would be awful beyond description. But we may rest assured that that Almighty Being who at first launched them into existence directs all their motions, however complicated; and that the earth shall remain secure against all such concussions from celestial agents, until the purposes of his moral government in this world shall be fully accomplished. What regions these bodies visit, when they pass beyond the limits of our view; upon what errands they are sent; when they again revisit the central parts of our system; what is the difference in their physical constitution, from that of the sun and planets; and what important ends they are destined to accomplish in

the economy of the universe; are inquiries which naturally arise in the mind, but which surpass the limited powers of the human understanding at present to determine. Of this, however, we may rest assured, that they were not created in vain; that they subserve purposes worthy of the infinite Creator; and that, wherever he has exerted his power, there also he manifests his wisdom and beneficence.\*

Such is a general outline of the leading facts connected with that system to which our earth belongs. Though the energies of Divine Power had never been exerted beyond the limits of this system, it would remain an eternal monument of the Wisdom and Omnipotence of its Author. Independently of the Sun, which is a vast universe in itself, and of the numerous comets which are continually traversing its distant regions, it contains a mass of material existence, arranged in the most beautiful order, two thousand five hundred times larger than our globe. From late observations, there is the strongest reason to conclude that the sun, along with all this vast assemblage of bodies, is carried through the regions of the universe toward some distant point of space, or around some wide circumference, at the rate of more than sixty thousand miles an hour; and if so, it is highly probable, if not absolutely certain, that we shall never again occupy that portion of *absolute space* through which we are this moment passing during all the succeeding ages of eternity.

Such a glorious system must have been brought into existence, to subserve purposes worthy of the

\* The periodical revolutions of the greater number of comets are accomplished only in long periods of time; some of them requiring hundreds and even thousands of years to finish their circuits. But, of late years, two comets have been discovered whose periodic revolutions are extremely short.—These are, 1st. The *comet of Encke*, whose periodic revolution is only 3200 days, or 3 years and three-tenths and becomes visible ten times in 33 years. It was discovered at Marseilles, by M. Pons, on the 23<sup>rd</sup> November 1818, and soon after M. Encke of Berlin determined its period by incontestable calculations. This comet has since regularly made its appearance. It was seen in Australia in June, 1822, and since that time in Europe, in 1825, 1828, 1832, 1835, and 1838. This comet is very small; its light is feeble; it has no tail, and it is invisible to the naked eye, except in very favorable circumstances.—The other comet to which we allude is distinguished by the name of *Bicla's* and sometimes *Gambart's comet*. This comet was first perceived at Johannisberg, on the 27<sup>th</sup> of February, 1795, by M. Bich, and ten days after by M. Gambart, at Marseilles, who calculated its orbit, and determined the period of its revolution to be 2160 days, or nearly 5 3/4 years. The predicted appearance of this comet in 1792 produced considerable alarm on the continent, particularly in France; as some German journalists had predicted that it would cross the earth's orbit near the point at which the earth would be at that time, and cause the destruction of our globe. This comet is a small body without a tail, or any appearance whatever of a solid nucleus, and is not distinguishable by the naked eye. It is not improbable that the observations which may hereafter be made on these comets, whose return is so frequent, will lead to more definite and accurate views of the nature and destination of these singular bodies. The only other comet whose period is determined is that which is known by the name of *Halley's comet*. This comet was observed by Dr. Halley in 1682, and, on calculating its elements, he was led to conclude that it was identical with the great comet of 1535, 1531, and 1607; and that its period is 75 or 76 years. He accordingly ventured to predict that it would again return about the latter part of 1758 or the beginning of 1759. It actually reappeared near the end of December, 1758, and arrived at its perihelion on the 13<sup>th</sup> March, 1759; and it again made its appearance, according to prediction, in September and October, 1835, having been seen in the particular positions previously predicted, a considerable time before it was visible to the naked eye. The appearance of this comet, so near the time predicted by astronomers, is a clear proof of the accuracy which has been introduced into astronomical calculations, and the soundness of the principles on which astronomers proceed. This circumstance likewise shows us that comets in general are *permanent* bodies belonging to that system of which we form a part.

Saturn. The primary planets are distinguished from the fixed stars, by the steadiness of their light; not having a *twinkling* appearance, as the stars exhibit.

Infinite Wisdom and Benevolence of the Creator. To suppose that the distant globes of which it is composed, with their magnificent apparatus of Rings and Moons, were created merely for the purpose of affording a few astronomers, in these latter times, a peep of them through their glasses, would be inconsistent with every principle of reason; and would be charging Him who is the Source of Wisdom with conduct which we would pronounce to be folly in the sons of men. Since it appears, so far as our observation extends, that matter exists only for the sake of sensitive and intelligent beings, and that the Creator made nothing in vain—it is a conclusion to which we are necessarily led, that the planetary globes are inhabited by various orders of intellectual beings, who participate in the bounty and celebrate the glory of their Creator.

When this idea is taken into consideration, it gives a striking emphasis to such sublime declarations of the Sacred Volume as these:—"All nations before him are as nothing—He sitteth upon the circle of the earth, and the inhabitants thereof are as grasshoppers—The nations are as the drop of a bucket—All the inhabitants of the world are reputed as nothing in his sight; and he doth according to his will in the armies of heaven and among the inhabitants of the earth—Thou hast made heaven and the heaven of heavens, with all their hosts; and thou preservest them all; and the host of heaven worshipeth thee—When I consider thy heavens, what is man that thou art mindful of him!" If the race of Adam were the principal intelligences in the universe of God, such passages would be stripped of all their sublimity, would degenerate into mere hyperboles, and be almost without meaning. If man were the only rational being who inhabited the MATERIAL WORLD, as some arrogantly imagine, it would be no wonder at all that God should be "mindful of him," nor could "all the inhabitants of this world," with any propriety, be compared to "a drop of a bucket," and be "reputed as nothing in his sight."—Such declarations would be contrary to fact, if this supposition were admitted; for it assumes that man holds the *principal station* in the visible universe. The expressions—"The heavens, the heaven of heavens," and "the host of heaven worshipping God," would also, on this supposition, degenerate into something approaching to mere inanity. These expressions, if they signify anything that is worthy of an Inspired Teacher to communicate, evidently imply that the universe is vast and extensive, beyond the range of human comprehension—that it is peopled with myriads of inhabitants—that these inhabitants are possessed of intellectual natures, capable of appreciating the perfections of their Creator—and, that they pay him a tribute of rational adoration: "The host of heaven worshipeth thee." So that the language of Scripture is not only consistent with the doctrine of a plurality of worlds, but evidently supposes their existence to all the extent to which the discoveries of modern science can carry us. However vast the universe now appears—however numerous the worlds, and systems of worlds, which may exist within its boundless range—the language of Scripture is sufficiently comprehensive and sublime, to express all the emotions which naturally arise in the mind when contemplating its structure; a characteristic which will apply to no other book, or pretended revelation. And this consideration shows not only the harmony which subsists between the discoveries of Revelation and the discoveries of Science, but also forms, by

itself, a strong presumptive evidence that the records of the Bible are authentic and divine \*

Vast as the Solar System we have now been contemplating may appear, it is but a mere point in the map of creation. To a spectator placed in one of the stars of the seventh magnitude, not only the glories of this world, and the more resplendent scenes of the planet Saturn, but even the sun himself would entirely disappear, as if he were blotted out of existence. "Were the sun," says Mr. Addison, "which enlightens this part of the creation, with all the host of the planetary worlds that move about him, utterly extinguished and annihilated, they would not be missed by an eye that could take in the whole compass of nature, more than a grain of sand upon the sea-shore. The space they possess is so exceedingly little in comparison of the whole, that it would scarcely make a blank in creation."

THE FIXED STARS.—When we pass from the planetary system to other regions of creation, we have to traverse, in imagination, a space so immense, that it has hitherto baffled all the efforts of science to determine its extent. In these remote and immeasurable spaces are placed those immense luminous bodies usually denominated the *fixed stars*. The nearest stars are, on good grounds, concluded to be at least *twenty billions* of miles distant from our globe—a distance through which *light* (the swiftest body in nature) could not travel in the space of three years; and which a ball, moving at the rate of 500 miles an hour, would not traverse in four millions, five hundred thousand years, or 750 times the period which has elapsed since the Mosaic creation. But how far they may be placed beyond this distance, no astronomer will pretend to determine. The following consideration will prove, to those unacquainted with the mathematical principles of astronomy, that the stars are placed at an immeasurable distance. When they are viewed through a telescope which magnifies objects a thousand times, they appear no larger than to the naked eye; which circumstance shows, that though we were placed at the thousandth part of the distance from them at which we now are, they would still appear only as so many shining *points*; for we should still be distant from the nearest of them, twenty thousand millions of miles; or, in other words, were we transported several thousands of millions of miles from the spot we now occupy, though their numbers would appear exceedingly increased, they would appear no larger than they do from our present station; and we behoved to be carried forward thousands of millions of miles farther in a long succession, before their discs appeared to expand into large circles like the moon. Sir W. Herschel viewed the stars with telescopes magnifying from *one to two or three thousand times*, yet they still appeared only as brilliant points, without any sensible discs or increase of diameter. This circumstance uncontestedly proves the two following things: 1. That the stars are *luminous bodies*, which shine by their own native light; otherwise they could not be perceived at such vast distances. 2. That they are bodies of an immense size, not inferior to the sun; and many of them, it is probable, far exceed that luminary in bulk and splendor.†

\* See Appendix, Note VI.

† Professor Bessel of Königsberg appears to have lately ascertained the annual parallax of the star *61 Cygni*, which he has determined to be somewhat less than *one-third of a second*, and consequently its distance must be 62,481,500,000,000, or sixty-two billions, four hundred and eighty-one thousand five hundred millions of miles—a distance which *light*, swift

For the conveniency of reference to particular objects and regions in the heavens, the stars have been arranged into different groups and *constellations*. The number of constellations recognized by modern astronomers is about 94; of which 12 are contained in the *Zodiac*, or that zone in the heavens in which the sun, moon, and planets are seen to perform their real or apparent revolutions; 35 are reckoned *North* of the zodiac, and 47 to the *South*, called the *Northern* and *Southern* constellations. These constellations are generally depicted on celestial globes and planispheres, as if they were represented by various animals and hieroglyphic objects, which give such exhibitions of the heavens a very grotesque and *unnatural* appearance. We have therefore given, in the following cut (fig. 23), a representation of the

constellation *Orion*, with the adjacent stars, on a more simple and *natural* plan, to show the manner in which the celestial constellations might be depicted on globes and planispheres, so as to make them resemble as much as possible their appearance in the heavens. This constellation makes a splendid appearance in the southern parts of the heavens during our winter months. The two large stars near the top toward the left, are *Betelgeuse* and *Bellatrix*; the three equidistant stars, near the middle, are *Orion's belt*, called in the book of Job, the "*bands of Orion*." The large star, near the bottom, on the right, is *Rigel*, a star of the first magnitude. A white line is drawn around this constellation to define its boundaries, and, in this way the form and limits of all the other constellations might be distinguished.

Fig. 23.

NORTH.

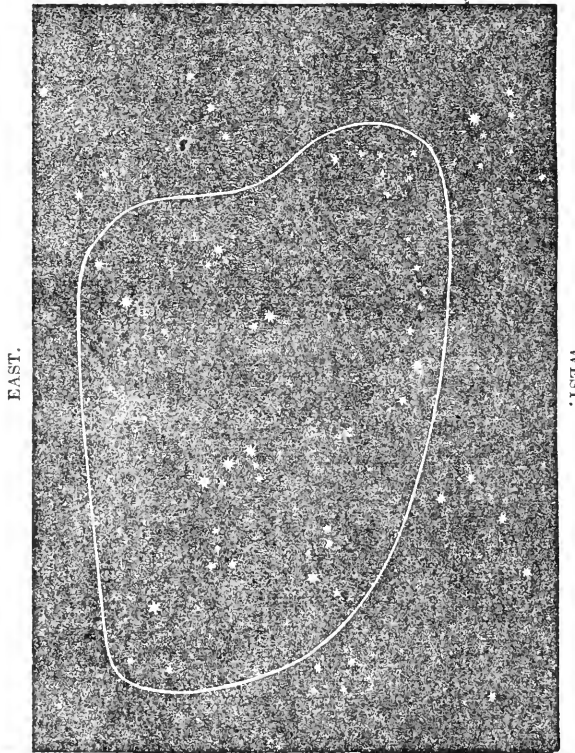

SOUTH.

The stars, on account of the difference in their apparent magnitudes, have been distributed into several classes or orders. Those which appear largest are called stars of the *first* magnitude; next to those in luster, stars of the *second* magnitude, and so on to stars of the *sixth* magnitude, which are the smallest that can be distinguished by the naked eye. Stars of the seventh, eighth, ninth, tenth, &c., magnitudes, which cannot be seen by the naked eye, are distinguished by the

name of the *telescopic* stars. Not more than a thousand stars can be distinguished by the naked eye in the clearest winter night; but by means of the telescope, millions have been discovered.\* And as it is probable, that by far the greater part lie beyond the reach of the best glasses which have been, or ever will be, constructed by man—the real number of the stars may be presumed to be beyond all human calculation or conception, and perhaps beyond the grasp of angelic comprehension.

In consequence of recent discoveries, we have now the strongest reason to believe, that all the stars in the universe are arranged into clusters, or groups, which astronomers distinguish by the

as its motion is, would require 10 years and 114 days to fly across this mighty interval; and a cannon ball, moving 500 miles every hour, would require fourteen millions, two hundred and fifty thousand years before it could move across the same interval.—For a more detailed account of this discovery of Bessel, the reader is referred to the author's volume entitled "*Sidereal Heavens*."

\* See page 21.

name of *NEBULÆ*, or *STARRY SYSTEMS*, each nebula consisting of many thousands of stars. The nearest nebula is that whitish space or zone which is known by the name of the *Milky Way*, to which our sun is supposed to belong. It consists of many hundreds of thousands of stars. When Sir W. Herschel examined this region with his powerful telescopes, he found a portion of it, only fifteen degrees long, and two broad, which contained *fifty thousand* stars large enough to be distinctly counted; and he suspected twice as many more, which, for want of sufficient light in his telescope, he saw only now and then. More than three thousand nebulae have already been observed; and, if each of them contain as many stars as the *Milky Way*, several hundreds of millions of stars must exist, even within that portion of the heavens which lies open to our observation. Beside those Nebulae which are resolvable into stars by telescopes, there are nebulous bodies in the heavens, of vast extent, such as the nebula in the sword of Orion, which the most powerful telescopes have hitherto been unable to resolve into stars. These are found in different degrees of condensation—from the resemblance of an irregular dusky cloud to the appearance of a well-defined body of faintish light, condensed to a bright spot in the center. They appear to be a species of fine luminous matter, distinct from stars and planets, diffused in immense masses throughout the spaces of the universe. It is an opinion now generally entertained that these self-luminous portions of matter are the chaotic materials out of which new suns and worlds may be formed under the superintendence of Omnipotence—and that each mass of this substance is gradually concentrating itself by the effect of its own gravity, and of the circular motions of which it is susceptible—into denser masses, so as ultimately to effect the arrangement and establishment of sidereal systems.

It appears, from numerous observations, that various changes are occasionally taking place in the regions of the stars. Several stars have appeared for a while in the heavens, and then vanished from the sight. Some stars which were known to the ancients, cannot now be discovered; and stars are now distinctly visible, which were to them unknown. A few stars have gradually increased in brilliancy, while others have been constantly diminishing in luster. Certain stars, to the number of fifteen or upwards, are ascertained to have a periodical increase and decrease of their luster, sometimes appearing like stars of the first or second magnitude, sometimes diminishing to the size of the fourth or fifth magnitude, and sometimes altogether disappearing to the naked eye. The late discoveries respecting *double* and *triple* stars are particularly worthy of attention. Some stars, which, to the naked eye, appear single, when examined by good telescopes, are found to consist of two, three, or more stars. In reference to *double stars*, one of the two is generally considerably smaller than the other, and it is now ascertained that, in many instances, the smaller star has a circular or elliptical motion around the larger. About 6000 double stars have already been detected; and between 40 and 50 of these bodies have been ascertained beyond doubt to form revolving systems. Some of these require 1600, others 1200, and others about 452 years to complete their revolutions; while some others finish their circuits in the short periods of 55, 43, and even 30 years. So that here we have *Suns* revolving around suns, and systems of worlds revolving around systems of worlds, in various

combinations, throughout the tracts of immensity. It also appears that changes are taking place among the Nebulae—that several nebulae are formed by the decomposition of larger nebulae, and that many nebulae of this kind are at present detaching themselves from the nebulae of the *Milky Way*. These changes seem to indicate, that mighty movements and vast operations are continually going on in the distant regions of creation, under the superintendence of the Sovereign of the Universe, upon a scale of magnitude and grandeur which overwhelms the human understanding.

To explore more extensively the region of the starry firmament; to mark the changes that are taking place; to ascertain all the changeable stars; to determine the periodical variations of their light; the revolutions of double and triple stars; and the motions and other phenomena peculiar to these great bodies—will furnish employment for future enlightened generations; and will perhaps form a part of the studies and investigations of superior intelligences, in a higher sphere of existence, during an indefinite lapse of ages.

If every one of these immense bodies be a *Sun*, equal or superior to ours, and encircled with a host of planetary worlds, as we have every reason to conclude to be the case,\* how vast must be the extent of creation! how numerous the worlds and beings which exist within its boundless range! and how great, beyond all human or angelic conception, must be the Power and Intelligence of that glorious Being who called this system from nothing into existence, and continually superintends all its movements! The mind is bewildered and confounded when it attempts to dwell on this subject: it feels the narrow limits of its present faculties; it longs for the powers of a seraph, to enable it to take a more expansive flight into those regions which "eye hath not seen;" and, while destitute of these, and chained down to this obscure corner of creation, it can only exclaim, in the language of inspiration, "Who can by searching find out God?—Great is our Lord, and of great power: his understanding is infinite!—Great and marvelous are thy works, Lord God Almighty!—Who can utter the mighty acts of Jehovah! who can show forth *all* his praise!"

After what has now been stated in relation to the leading facts of Astronomy, it would be needless to spend time in endeavoring to show its connection with Religion. It will at once be admitted, that all the huge globes of luminous and opaque matter to which we have adverted, are the workmanship of Him "who is wonderful in counsel, and excellent in working;" and form a part of the dominions of that august Sovereign, "whose kingdom ruleth over all." And shall it ever be insinuated, that this subject has no relation to the great object of our adoration? and that it is of no importance in our views of the Divinity, whether we conceive his dominions as circumscribed within the limits of little more than 25,000 miles, or as embracing an extent which comprehends innumerable worlds! The objects around us in this sublunary sphere, strikingly evince the superintendency, the wisdom, and benevolence of the Creator: but this science demonstrates, beyond all other departments of human knowledge, the *GRANDEUR* and *MAGNIFICENCE* of his operations; and raises the mind to sublimer views of his attributes than can be acquired by the contemplation of any other objects. A serious contemplation of the sublime objects which Astronomy has ex-

\* See pp. 10, 23.



plored, must therefore have a tendency to inspire us with profound veneration of the Eternal Jehovah—to humble us in the dust before his august presence—to excite admiration of his condescension and grace in the work of redemption—to show us the littleness of this world, and the insignificance of those riches and honors to which ambitious men aspire with so much labor and anxiety of mind—to demonstrate the glory and magnificence of God's universal kingdom—to convince us of the infinite sources of varied felicity which he has in his power to communicate to holy intelligences—to enliven our hopes of the splendors of that "exceeding great and eternal weight of glory," which will burst upon the spirits of good men, when they pass from this region of mortality—and to induce us to aspire with more lively ardor after that heavenly world, where the glories of the Deity, and the magnificence of his works, will be more clearly unfolded.

If, then, such be the effects which the objects of astronomy have a tendency to produce on a devout and enlightened mind—to call in question the propriety of exhibiting such views in religious publications, or in the course of religious instructions, would be an approach to impiety, and an attempt to cover with a veil the most illustrious visible displays of Divine glory.—It forms a striking evidence of the depravity of man, as well as of his want of true taste, and of a discernment of what is excellent, that the grandeur of the nocturnal heavens, and the perfections of Deity they proclaim, are beheld with so much apathy and indifference by the bulk of mankind. Though "the heavens declare the glory of God," in the most solemn and impressive language, adapted to the comprehension of every kindred and every tribe, yet "a brutish man knoweth not, neither doth a fool understand this." They can gaze upon these resplendent orbs with as little emotion as the ox that feeds on the grass, or as the horse that drags their carriages along in their chariots. They have even attempted to ridicule the science of the heavens, to caricature those who have devoted themselves to such studies, and to treat with an indifference, mingled with contempt, the most august productions of Omnipotence. Such persons must be considered as exposing themselves to that Divine denunciation—"Because they regard not the works of Jehovah, neither consider the operations of his hands, he will destroy them, and not build them up." If the structure of the heavens, and the immensity of worlds and beings which they contain, were intended by the Creator to *adumbrate*, in some measure, his invisible perfections, and to produce a sublime and awful impression on the minds of all created intelligences,\* it must imply a high degree of disrespect to the Divinity, willfully to overlook these astonishing scenes of Power and Intelligence. It is not a matter of mere taste or caprice, whether or not we direct our thoughts to such subjects, but an imperative duty, to which we are frequently directed in the word of God; the *willful neglect* of which, where there is an opportunity of attending to it, must subject us to all that is included in the threatening now specified, if there be any meaning in language.

That the great body of professed Christians are absolute strangers to the sublime sentiments which a serious contemplation of the heavens inspires, must be owing, in part, to the minds of Christian parents and teachers not having been directed to

such subjects, or to the views they entertain respecting the relation of such contemplations to the objects of religion. In communicating religious instructions in reference to the attributes of God, the heavens are seldom referred to, except in such a vague and indefinite manner as can produce no deep nor vivid impression on the mind; and many pious persons whose views have been confined to a narrow range of objects, have been disposed to declaim against such studies, as if they had a tendency to engender pride and self-conceit, and as if they were even dangerous to the interests of religion and piety. How very different were the feelings and the conduct of the sacred writers! They call upon every one of God's intelligent offspring to "stand still and consider the wondrous works of the Most High;" and describe the profound emotions of piety which the contemplation of them produced on their own minds: "Lift up your eyes on high, and behold! Who hath created these things? The heavens declare the glory of God, and the firmament showeth his handiwork. When I consider thy heavens, the work of thy fingers, the moon and the stars, which thou hast ordained; what is man, that thou art mindful of him? and the son of man, that thou visitest him? Thou, even thou, art Lord alone: thou hast made heaven, and the heaven of heavens, with all their host, and thou preservest them all; and the hosts of heaven worship thee. All the gods of the nations are idols; but the Lord MADE THE HEAVENS; honor and majesty are before him. Jehovah hath prepared his THRONE in the heavens; and his kingdom ruleth over all.—Sing praises unto God, ye kingdoms of the earth, to him that rideth on the heaven of heavens. Ascribe ye power to our God; for his strength is in the heavens. Praise him for his mighty acts, praise him according to his excellent greatness."—If we would enter with spirit into such elevated strains of piety, we must not content ourselves with a passing and vacant stare at the orbs of heaven, as if they were only so many brilliant *studs* fixed in the canopy of the sky; but must "consider" them with fixed attention, in all the lights in which revelation and science have exhibited them to our view, if we wish to praise God for his mighty works, and "according to his excellent greatness." And, for this purpose, the conclusions deduced by those who have devoted themselves to celestial investigations, ought to be presented to the view of the intelligent Christian, that he may be enabled to "speak of the glory of Jehovah's kingdom, and to talk of his power."

#### NATURAL PHILOSOPHY.

Having, in the preceding sketches, considerably exceeded the limits originally prescribed for this department of my subject, I am reluctantly compelled to dispatch the remaining sciences with a few brief notices.

The object of *Natural Philosophy* is, to observe and describe the phenomena of the material universe, with a view to discover their causes, and the laws by which the Almighty directs the movements of all bodies in heaven and on earth. It embraces an investigation of the laws of gravitation, by which the planets are directed in their motions; the laws by which water, air, light, and heat, are regulated, and the effects they produce in the various states in which they operate; the nature of colors, sounds, electricity, galvanism, and magnetism, and the laws of their operation; the causes which operate in the production of

\* See pp. 21, 24.



thunder, lightning, luminous and fiery meteors, hail, rain, snow, dew, and other atmospherical phenomena. In short, it embraces all the objects of Natural History formerly alluded to, with a view to ascertain the causes of their varied appearances, and the principles that operate in the changes to which they are subject; or, in other words, the laws by which the diversified phenomena of universal nature are produced and regulated. One subordinate use of the knowledge derived from this science, is, to enable us to construct all those mechanical engines which facilitate human labor, and increase the comforts of mankind, and all those instruments which tend to enlarge our views of the operations of nature. A still higher and nobler use to which philosophy is subservient, is to demonstrate the Wisdom and Intelligence of the Great First Cause of all things, and to enlarge our conceptions of the admirable contrivance and design which appear in the different departments of universal nature. In this view, it may be considered as forming a branch of *Natural Theology*, or, in other words, a branch of the religion of angels, and of all other holy intelligences.

This department of natural science has generally been divided into the following branches:—

I. **MECHANICS.**—This branch, considered in its most extensive range, includes an investigation of the general properties of matter; such as solidity, extension, divisibility, motion, attraction, and repulsion—the law of gravitation, and of central forces, as they appear to operate in the motions of the celestial bodies; and on the surface of our globe, in the phenomena of falling bodies, the motions of projectiles, the vibration of pendulums, etc.,—the theory of machines, the principles on which their energy depends; the properties of the mechanical powers—the *lever*, the *wheel and axle*, the *pulley*, the *inclined plane*, the *wedge*, and the *screw*,—and the effects resulting from their various combinations. From the investigations of philosophers on these subjects, we learn the laws by which the great bodies of the universe are directed in their motions; the laws which bind together the different portions of matter on the surface of the earth, and which regulate the motions of animal, vegetable, and inanimate nature; and the principles on which cranes, mills, wheel-carriages, thrashing-machines, pile-engines, locomotive carriages, and other engines, are constructed; by means of which man has been enabled to accomplish operations far beyond the limits of his own physical powers.

Without a knowledge of the laws of motion, and assistance from the combined effects of the mechanical powers, man would be a very limited being, his enjoyments would be few, and his active energies confined within a very narrow range. In a savage state, ignorant of manufactures, agriculture, architecture, navigation, and the other arts which depend upon mechanical combinations, he is exposed, without shelter, to the inclemencies of the seasons; he is unable to transport himself beyond seas and oceans, to visit other climes, and other tribes of his fellow-men; he exists in the desert, comfortless and unimproved; the fertile soil, over which he roams, is covered with thorns and briars, and thickets, for the want of beasts of prey; his enjoyments are little superior to those of the lion, the hyena, and the elephant, while he is much their inferior in point of agility and physical strength. But, when philosophy has once demonstrated the principles of Mechanics, and introduced the practice of the

useful Arts, “the wilderness and the solitary place are made glad, and the desert rejoices and blossoms as the rose.” Cities are founded, and gradually rise to opulence and splendor; palaces and temples are reared; the damp cavern, and the rush-built hut, are exchanged for the warm and comfortable apartments of a substantial mansion; ships are built, and navigated across the ocean; the treasures of one country are conveyed to another; an intercourse is carried on between the most distant tribes of mankind; commerce flourishes, and machinery of all kinds is erected for facilitating human labor, and promoting the enjoyments of man. And, when the principles and the practice of “pure and undefiled religion” accompany these physical and mechanical operations, love and affection diffuse their benign influence; the prospect brightens as years roll on, and man advances, with pleasure and improvement, to the scene of his high destination.

II. **HYDROSTATICS** treats of the *pressure and equilibrium of fluids*. From the experiments which have been made in this branch of philosophy, the following important principles, among many others, have been deduced:—

(1.) *That the surface of all waters which have a communication while they are at rest, will be perfectly level.*—This principle will be more clearly understood by an inspection of the following figures. If water be poured into the tube A (fig. 24), it will run through the horizontal tube E, and rise in the opposite tube B, to the same height at which it stands at A. It is on this principle that water is now conveyed under ground, through conduit pipes, and made to rise to the level of the fountain whence it is drawn. The city of Edinburgh, a considerable part of which is elevated above the level of the surrounding country, is supplied with water from a reservoir on the Pentland hills, several miles distant. The water is con-

Fig. 24.

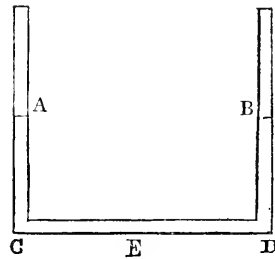

veyed in leaden pipes down the declivity of the hill, along the interjacent plain, and up to the entrance of the castle, whence it is distributed to all parts of the city. If the point A represent the level of the reservoir, C D will represent the plain along which the water is conveyed, and B the elevation to which it rises on the Castle-hill. On the same principle, and in a similar manner, the city of London is supplied with water from water-works at the London bridge. Had the ancients been acquainted with this simple, but important principle, it would have saved them the labor and expense of rearing those stupendous works of art, the *Aqueducts*, which consisted of numerous arches of vast size, and sometimes piled one above another.

Fig. 25 represents the *siphon*, the action of which depends upon the pressure of the atmo-

Fig. 25

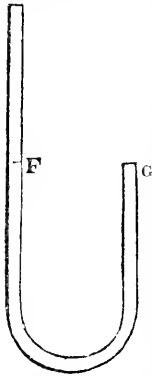

sphere. If this instrument be filled with water, or any other liquid, and the shorter leg G plunged to the bottom of a cask, or other vessel containing the same liquid, the water will run out at the longer leg F, until the vessel be emptied, in consequence of the atmospheric pressure upon the surface of the liquid. On this principle water may be conveyed over a rising ground to any distance, provided the perpendicular height of the syphon above the surface of the water in the fountain does not exceed thirty-two or thirty-three feet. On the same principle are constructed the *fountain at command*, the *cup of Tantalus*, and other entertaining devices. The same principle, too, enables us to account for springs which are sometimes found on the tops of mountains, and for the phenomena of *intermitting springs*, or those which flow and stop by regular alternations.

The following figure will explain the nature of intermitting springs. Suppose A B a cavity or receptacle of water formed in the bowels of a hill where the spring is situated, which gradually fills with water like other reservoirs, and that by the interposition of some stratum of rock or other substance, the tube C D, which conveys the water to the spring or mouth where it issues—is bent in the form of a syphon; whenever the reservoir A B is filled as high as the bend of the tube, or to the level of *h i*, the water will rise in the tube, and begin to flow into the spring, which will continue until the reservoir be exhausted. While this process is going on, the water in the spring will rise, and as soon as the reservoir is exhausted, the water will appear to fall in the well of the spring, and will continue to fall until the reservoir

is again supplied to the height of the syphon when the process of filling will be again renewed. It is obvious that unless the water in the reservoir rises above the height of the bend of the syphon E, the well cannot be filled.

(2.) *Any quantity of fluid, however small, may be made to counterpoise any quantity, however large.* This is what has generally been termed the *Hydrostatical Paradox*; and from this principle it follows, that a given quantity of water may exert a force several hundred times greater or less, according to the manner in which it is employed. This force depends on the *height* of the column of water, independent of its quantity; for its *pressure* depends on its perpendicular height. By means of water conveyed through a very small perpendicular tube, of great length, a very strong hogshead has been burst to pieces, and the water scattered about with incredible force. On this principle, the *hydrostatic press*, and other engines of immense power, have been constructed.

(3.) *Every body which is heavier than water, as it sinks in it, displaces so much of the water as is equal to the bulk of the body immersed in the water.*—On this principle, the specific gravities, or comparative weight, of all bodies are determined. It appears to have been first ascertained by Archimedes, and by means of it, he determined that the golden crown of the king of Syracuse had been adulterated by the workmen. From this principle we learn, among many other things, the specific gravity of the human body; and that four pounds of cork will preserve a person weighing 135 pounds from sinking, so that he may remain with his head completely above water.

*Hydraulics*, which has sometimes been treated as a distinct department of mechanical philosophy, may be considered as a branch of Hydrostatics. It teaches us what relates to the *motion of fluids*, and how to estimate their velocity and force. On the principles of this science, all machines worked by water are constructed—as steam-engines, water-mills, common and forcing pumps, syphons, fountains, and fire-engines.

Fig. 26.

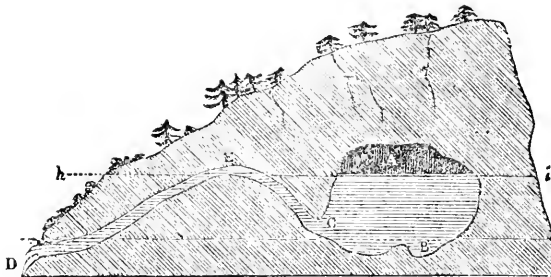

III. PNEUMATICS.—This branch of philosophy treats of the nature and properties of the atmosphere, and of their effects on solid and fluid bodies. From this science we learn that air has *weight*, and presses on all sides like other fluids; that the pressure of the atmosphere upon the top of a mountain is less than on the plain beneath; that it presses upon our bodies with the weight of several thousand pounds more at one time than at another; that air can be compressed into forty thousand times less space than it naturally occupies; that it is of an elastic or expansive nature, and that the force of its spring is equal to its weight; that its elasticity is increased by heat; that it is necessary to the production of sound, the support

of flame and animal life, and the germination and growth of all kinds of vegetables.

These positions are proved and illustrated by such experiments as the following:—The general *pressure* of the atmosphere is proved by such experiments as those detailed in Note II of the Appendix. The following experiment proves that air is *compressible*. If a glass tube, open at one end, and close at the other, be plunged, with the open end downward, into a tumbler of water, the water will rise a little way in the tube; which shows, that the air which filled the tube is compressed by the water into a smaller space. The *elasticity* of air is proved by tying up a bladder, with a very small quantity of air within it

and putting it under the receiver of an air-pump, when it will be seen gradually to inflate, until it becomes of its full size. A similar effect would take place, by carrying the bladder to the higher regions of the atmosphere. On the compression and elasticity of the air, depends the construction of that dangerous and destructive instrument, the Air-gun. That it is capable of being rarefied by heat, is proved by holding to the fire a half-blown bladder, slightly tied at the neck, when it will dilate to nearly its full size; and if either a *full blown* bladder, or a thin glass bubble filled with air, is held to a strong fire, it will burst. The elasticity of the air is such, that Mr. Boyle, by means of an air-pump, caused it to dilate until it occupied fourteen thousand times the space that it usually does. That the air is necessary to sound, flame, animal and vegetable life, is proved by the following experiments:—When the receiver of an air-pump is exhausted of its air, a cat, a mouse, or a bird, placed in it, expires in a few moments, in the greatest agonies. A bell rung in the same situation produces no sound; and a lighted candle is instantly extinguished. Similar experiments prove that air is necessary for the flight of birds, the ascent of smoke and vapors, the explosion of gunpowder, and the growth of plants; and that all bodies descend equally swift in a place void of air; a guinea and a feather being found to fall to the bottom of an exhausted receiver at the same instant.

On the principles which this science has established have been constructed the air-pump, the barometer, the thermometer, the diving-bell, the hygrometer, the condenser, and various other instruments, which have contributed to the comfort of human life, and to the enlargement of our knowledge of the constitution of nature.

IV. ACOUSTICS.—This science treats of the nature, the phenomena, and the laws of *sound*, and the theory of musical concord and harmony.—From the experiments which have been made on this subject, we learn, that air is essential to the production of sound; that it arises from *vibrations* in the air, communicated to it by vibrations of the sounding body; that these vibrations, or aerial pulses, are propagated all around in a spherical undulatory manner; that their density decreases as the squares of the distances from the sounding body increase; that they are propagated together in great numbers from different bodies without disturbance or confusion, as is evident from concerts of musical instruments; that water, timber, and flannel, are also good conductors of sound; that sound travels at the rate of 1142 feet in a second, or about thirteen miles in a minute;\* that the softest whisper flies as fast as the loudest thunder; and that the utmost limits, within which the loudest sounds, produced by artificial means, can be heard, is 180 or 200 miles;† that sound,

\* The velocity of sound has been somewhat differently estimated by different experimenters. Mr. Boyle estimated its velocity at 1200 feet; the Florentine Academicians at 1148 feet; the French Academicians at 1172 feet per second. It is reckoned by some modern philosophers that 1120 feet per second may be reckoned as a medium estimate. The experiments of Flamstead, Halley, and Derham, which were considered as having been accurately performed, give 1142 feet per second, as the average velocity of sound—which is sometimes modified by the direction of the wind and local circumstances.

† In the war between England and Holland, in 1672, the noise of the guns was heard in those parts of Wales which were estimated to be two hundred miles distant from the scene of action. But the sounds produced by volcanoes have been heard at a much greater distance; some instances of which are stated in Chap. IV, Sect. 2. Several other facts, in relation to sound are detailed in Chap. III, Art. *Acoustic Tunnels*.

striking against an obstacle, as the wall of a house, may, like light, be reflected, and produce another sound, which is called an *echo*; and that, after it has been reflected from several places, it may be collected into one point or focus, where it will be more audible than in any other place.

The intensity of sound increases or diminishes when the elasticity of the air increases or diminishes, either by heat or by compression. Hence, in proportion as the air is rarefied under the receiver of an air-pump, or in the ascent of lofty mountains, sound loses its force. Air communicates its vibrations to the sonorous bodies with which it is in contact. Hence a string of an instrument causes another stretched beside it to vibrate. A noise without makes the windows of an apartment to resound, and the discharge of cannons, and peals of thunder, cause buildings, and even whole villages to shake. Euler tells us of a man who, by different inflections of his voice, made a glass vibrate so as almost to break it.—When the velocity of sound is known, the distance of certain objects may be determined. If a flash of a gun be observed, and the number of seconds or pulsations which elapse between seeing the flash and hearing the report, be counted, this number multiplied by 1142, the assumed velocity of sound per second, will give the distance of the observer from the center of vibration. If, in a thunder storm, I can count five pulsations, from the instant of seeing the lightning until the report of the thunder be heard, the distance of the thunder cloud will be  $1142 \times 5 = 5710$  feet, that is, an English mile and 430 feet. Were the thunder to be heard within a second of the time of seeing the flash, it would indicate that the thunder was within 380 yards of the observer, and consequently, that he is within the sphere of danger.—In estimating such distances  $\frac{1}{2}$  seconds, at an average, may be reckoned for every mile.

On the principles above stated we may account for the various phenomena of sounds and the diversified *echoes* which are heard in various places, which both amuse and sometimes puzzle the observers—and on the same principles whispering galleries, such as that in St. Paul's church, London, speaking and hearing trumpets—wind and stringed instruments—the *Harmonica Celestina*, and other acoustic instruments, are constructed.

V. OPTICS.—This branch of philosophy treats of vision, light, and colors, and of the various phenomena of visible objects produced by the rays of light, reflected from mirrors, or transmitted through lenses. From this science we learn, that light flies at the rate of nearly twelve millions of miles every minute—that it moves in straight lines—that its particles may be several thousands of miles distant from each other—that every visible body emits particles of light from its surface, in all directions—that the particles of light are *exceedingly small*; for a lighted candle will fill a cubical space of two miles every way with its rays, before it has lost the least sensible part of its substance; and millions of rays, from a thousand objects will pass through a hole not larger than the point of a needle, and convey to the mind an idea of the form, position, and color, of every individual object—that the intensity, or degree of light decreases, as the square of the distance from the luminous body increases; that is, at two yards distance from a candle, we shall have only the fourth part of the light we should have at the distance of one yard; at three yards distance, the ninth part; at four yards, the sixteenth part, and so on—that glass lenses may be ground into the following forms: *plano-convex, plano-con-*

*cave, double convex, double concave, and meniscus*, that is, convex on one side, and concave on the other—that specula, or mirrors, may be ground into either a spherical, parabolical, or cylindrical form—that, by means of such mirrors and lenses, the rays of light may be so modified as to proceed either in a *diverging, converging, or parallel* direction, and the images of visible objects represented in a variety of new *forms, positions, and magnitudes*.—that every ray of white light may be separated into seven primary colors: *red, orange, yellow, green, blue, indigo, and violet*—that the variegated coloring which appears on the face of nature is not in the objects themselves, but in the light which falls upon them—that the *rainbow* is produced by the refraction and reflection of the solar rays in the drops of falling rain—that the rays of light are refracted, or bent out of their course, when they fall upon glass, water, and other mediums—that the light of the sun may be collected into a point or focus, and made to produce a heat more intense than that of a furnace\*—that the rays from visible objects, when reflected from a concave mirror, converge to a focus, and paint an image of the objects before it, and that when they pass through a convex glass, they depict an image behind it.

On these and other principles demonstrated by this science, the Camera Obscura, the Magic Lantern, the Phantasmagoria, the Kaleidoscope, the Heliostata, the Micrometer—Spectacles, Opera Glasses, Prisms, single, compound, lucernal, and solar Microscopes, reflecting and refracting Telescopes, and other optical instruments, have been constructed, by means of which the natural powers of human vision have been wonderfully increased, and our prospects into the works of God extended far beyond what former ages could have conceived.

Connected with the science of Optics, it may be proper to notice a late discovery for fixing the images formed by convex lenses, distinguished by the name of the DAGUERRETYPE. Almost every one knows the effects produced by the *Camera Obscura*. A convex glass placed in an opening in a window-shutter in a dark room, or in a box constructed for the purpose, forms, on a white screen, placed at its focal distance, a beautiful picture of all the objects which are opposite to it, in their exact proportions, symmetry, and colors. But this picture evanishes the moment the lens or the screen is removed. The Daguerreotype is an art by which this picture or image may be rendered permanent. It derives its name from M. Daguerre, a member of the French Academy of Fine Arts, who was in partnership with M. Ni-

per, who, as early as 1814, had commenced researches on this subject; but Daguerre had given up the idea of being able to bring his methods to perfection, until about the year 1833, when the effects produced by his art began to excite a considerable degree of attention; and as a reward for disclosing the process and publishing it to the world, the French government bestowed on the inventor and his partner an annuity of ten thousand francs (£416 l. s. 4d.): M. Arago, when alluding to this discovery, has the following remark: "No person has ever witnessed the neatness of outline, precision of form, the truth of coloring, and the sweet gradations of tint, displayed by the Camera, without regretting that an imagery so exquisite and so faithful to nature could not be made to fix itself permanently on the tablet of the machine—who has not put up his aspiration that some means might be discovered by which to give reality to shadows so lovely! Yet in the estimation of all, such a wish seemed destined to take its place among other dreams of beautiful things—among the glorious but impracticable conceptions in which men of science and ardent temperament have sometimes indulged. *This dream, notwithstanding, has just been realized.*"

Our limits will not permit to give a detail of the process by which the effect now stated is produced. We shall just state the following general outline.—The designs taken by the Daguerreotype are executed upon thin plates of silver plated on copper. The silver must be of the purest kind, and the thickness of both metals not to exceed that of a stout card. Before placing it in the Camera the following operations are requisite: 1. The plate must be cleansed and highly polished. For this purpose a little of fine pumice powder is put into a muslin bag and shaken over the plate, and it is then rubbed gently with cotton dipped in olive oil. Diluted nitric acid is then rubbed over the plate with cotton, and then rubbed again with pumice and dry cotton; and afterward the plate is to be subjected to a strong heat. 2. The plate has to receive a coating of Iodine. To accomplish this the plate is fixed upon a board, and then put into a box containing a little dish with iodine divided into small pieces, and allowed to remain until it is covered with a *gold-colored* coating, which process must be conducted in a darkened apartment. 3. The Camera is next placed in the front of the landscape or object, and as soon as the focus is adjusted, the light is excluded, and the plate put in, when, in the course of a few minutes, and in some cases, in a few seconds, a perfect picture or design is obtained. I have seen a portrait of an individual taken in this way in the course of half a minute. 4. The plate is next placed over the vapor of mercury to bring out the image, which is not visible when withdrawn from the Camera. The image is not visible until after the lapse of several minutes. 5. The coating on which the design was impressed is to be removed in order to preserve it from being decomposed by the rays of light. To do this, the plate is placed in a trough containing common water, plunging and withdrawing it immediately, and then plunging it into a solution of salt and water until the yellow coating has disappeared.

Such is a very abridged sketch of the photographic operations of M. Daguerre. When finished in a perfect way, the designs thus taken on the plate are exceedingly beautiful and correct, and will bear to be inspected with a considerable magnifying power, so that the most minute portions

\* This is produced by means of lenses, or mirrors, of a large diameter, called burning-glasses. By these instruments, the hardest metals, on which common fires, and even glass-house furnaces, could produce no effect, have been melted in a few seconds. M. Vilette a Frenchman, nearly a century ago, constructed a mirror, three feet eleven inches in diameter, and three feet two inches in focal distance, which melted *copper ore* in eight seconds, *iron ore* in twenty-four seconds, a fish's tooth in thirty-two seconds, *cast iron* in sixteen seconds, a silver sixpence in seven seconds, and *tin* in three seconds. This mirror condensed the solar rays 17,257 times, a degree of heat which is about *four hundred and ninety times* greater than common fire. Mr. Parker, of London, constructed a lens three feet in diameter, and six feet eight inches focus, which weighed 212 lbs. It melted twenty grains of gold in four seconds, and ten grains of platinum in three seconds. The power of burning-glasses is, as the area of the lens directly, and the square of the focal distance inversely—or, in other words, the broader the mirror or lens, and the shorter the focal distance, the more intense is the heat produced by such instruments. A globular decanter of water makes a powerful burning-glass; and house furniture has been set on fire, by incautiously exposing it to the rays of the sun.

of the objects delineated may be perceived; and it has been discovered that an etching of the design can be taken in the common way, and from that again any number of electrotype copies can be produced. M. Claudet, the patentee of this invention at the Adelaide gallery, London, has made several improvements, particularly in taking likenesses. He is now enabled to take a likeness in one second, and even less—in the twinkling of an eye, and to give the portraits so made any background that may be desired.

This invention may be considered as still in its infancy; but in the course of its improvement, its results may be highly beneficial and extensive. To use the words of Arago: "To copy the millions of millions of hieroglyphics, which entirely cover to the very exterior of the great monuments at Thebes, Memphis, Carnoe, etc., would require scores of years and legions of artists. With the Daguerreotype a single man would suffice to bring to a conclusion this vast labor; and at the same time, such designs shall incomparably surpass in fidelity, in truth of local color, the works of the ablest artists." It is probable, too, that this art may be applied to taking exact pictures of the heavenly bodies—not only of the sun, but even of the moon, the planets, and the stars. The plated discs prepared by Daguerre receive impressions from the action of the lunar rays to such an extent as permits the hope that photographic charts of the moon may soon be obtained. Nor is it perhaps too much to expect that the rays of the stars—even of distant nebulae may thus be fixed and a delineation of their objects produced which shall be capable of being magnified by powerful microscopes.—This invention leads us to conclude that we have not yet discovered all the wonderful properties of that *Licor* which unravels to us the beauties and sublimities of the universe; and that thousands of admirable agencies and objects hitherto unknown, may soon be disclosed to our view through this medium, as we advance in our researches and discoveries.

VI. ELECTRICITY.—This name has been given to a science which explains and illustrates the operations of a very subtle fluid, called the *electric fluid*, which appears to pervade every part of nature, and to be one of the chief agents employed in producing many of the phenomena of the material world. If a piece of amber, sealing-wax, or sulphur, be rubbed with a piece of flannel, it will acquire the power of attracting small bits of paper, feathers, or other light substances. If a tube of glass, two or three feet in length, and an inch or two in diameter, be rubbed pretty hard, in a dark room, with a piece of dry woolen cloth, beside attracting light substances, it will emit flashes of fire, attended with a crackling noise. This luminous matter is called electricity, or the *electric fluid*. If a large globe, or cylinder of glass, be turned rapidly round, and made to rub against a cushion, streams and large sparks of bluish flame will be elicited, which will fly round the glass, attract light bodies, and produce a pungent sensation, if the hand be held to it. This glass, with all its requisite apparatus, is called an *electrical machine*. It is found that this fluid will pass along some bodies, and not along others. The bodies over which it passes freely are water, and most other fluids, except oil and the aerial fluids; iron, copper, lead, and in general all the metals, semi-metals, and metallic ores; which are therefore called *conductors* of electricity. But it will not pass over glass, resin, wax, sulphur, silk, baked woods, or dry woolen substances; nor through air, except by force, *in sparks*, to short

distances. These bodies are therefore called *non-conductors*.

The following facts, among others, have been ascertained respecting this wonderful agent:—That all bodies with which we are acquainted possess a greater or less share of this fluid—that the quantity usually belonging to any body produces no sensible effects; but when any surface becomes possessed of *more or less* than its natural share, it exhibits certain appearances in the form of light, sound, attraction, or repulsion, which are ascribed to the power called *electric*—that there are two different species of the electrical fluid, or at least two different modifications of the same general principle, termed *positive* and *negative* electricity—that positive and negative electricity always accompany each other; for if a substance acquire the one, the body with which it is rubbed acquires the other—that it moves with amazing rapidity, having been transmitted through wires of several miles in length, without taking up any sensible space of time; and therefore it is not improbable, that were an insulated conducting substance extended from one continent to another, it might be made to fly to the remotest regions of the earth in a few seconds of time\*—that it has a power of suddenly contracting the muscles of animals, or of giving a *shock* to the animal frame—that this shock may be communicated, at the same instant, to a hundred persons, or to any indefinite number who form a circle, by joining their hands together—that it may be accumulated to such a degree as to kill the largest animals—that vivid sparks of this fluid, attended with a crackling noise, may be drawn from different parts of the human body, when the person is *insulated*, or stands upon a stool supported by glass feet—that electricity sets fire to gunpowder, spirits of wine, and other inflammable substances—that it melts iron wire and destroys the polarity of the magnetic needle—that it augments the natural evaporation of fluids, promotes the vegetation of plants, and increases the insensible perspiration of animals; and can be drawn from the clouds by means of electrical kites, and other elevated conductors. By means of the electrical power, small models of machinery have been set in action; orreries to represent the movements of the planets have been put in motion; and small bells have been set ringing for a length of time; and, in consequence of the knowledge we have acquired, of the mode of its operation in the system of nature, the lightnings of heaven have been arrested in their course, and constrained to descend to the earth, without producing any injurious effects.

From these, and a variety of other facts and experiments, it is now fully ascertained, that *lightning* and electricity are identical; and that it is the prime agent in producing the awful phenomena of a thunder-storm; the lightning being the rapid motion of vast masses of electric matter, and *thunder* the noise, with its echoes, produced by the rapid motion of the lightning through the atmosphere.—There can be little doubt that in combination with steam, the gases, and other agents, it also produces many of the terrific phenomena of earthquakes, volcanoes, whirlwinds, water-spouts, and hurricanes, and the sublime coruscations of the *aurora borealis*.—In the operations of this powerful fluid, we behold a striking display of the sovereignty and majestic agency of God. In directing its energies, "his way is in the whirlwind and the storm, and the clouds are

\* See Chap. III, Art. ELECTRIC TELEGRAPH.

the dust of his feet; the heavens are covered with sackcloth, the mountains quake before him, the hills melt, the earth is burned at his presence, and rocks are thrown down by him."\* It is easy to conceive, that by a few slight modifications produced by the hand of Omnipotence, this powerful fluid might become the agent of producing either the most awful and tremendous, or the most glorious and transporting scenes, over every region of our globe. As it now operates, it is calculated to inspire us rather with awe and terror than with admiration and joy; and to lead our thoughts to a consideration of the state of man as a depraved intelligence, and a rebel against the government of his Maker.

Electricity is rapidly extending its boundaries, and its influence as an important agent in the arts; and, as yet, we can form no adequate conception of the results which may flow from the investigations into its nature, combinations, and applications, which are now making by the scientific world, or of the powerful effects it may produce, when thoroughly wielded by the hand of genius. It has already been applied to many useful purposes—to remove obstructions in the human frame—to cure diseases—to ascertain the depths of the sea—to produce explosions for effecting mechanical operations,—and for conveying intelligence at the rate of 192,000 miles in a second. Among its recent applications is the process of copying with perfect accuracy engraved copperplates, medals, seals, &c.—and of gilding, plating, and etching, with great beauty and precision. This art has been denominated *ELECTROTYPE*, and was discovered by Mr. Thomas Spencer, of Liverpool, in 1839. It was also discovered on the Continent by Professor Jacobi. The materials recommended by him for forming the molis on which impressions are taken are *finest metal, wax, and stearine*. When a copy is taken from any copperplate or medal, any number of copies can be produced equally as good as the first. The process is simple, but our limits will not permit to enter into its details. The reader will find a short description of the process in Chambers' "Information for the People," No. 57, Art. *Electricity, &c.*, and in the "Practical Mechanic and Engineer's Magazine," vol. 1, p. 227.

An important combination of the Electrotype with the Daguerreotype process has lately been discovered, which promises to lead to some important results. A Daguerreotype picture can be produced in the ordinary way, as formerly described—it can be etched according to the present process, and from this etching an indefinite number of electrotype copies can be obtained. As an illustration of the perfection attendant on this process, the inventor states that, from a Daguerreotype plate which had on it a sign-board measuring 1-10th by 6-100ths of an inch, five lines of the inscription can be distinctly read by the aid of a microscope applied to the electrotype copy. So that, as the author remarks, "instead of a plate being inscribed as drawn by Landseer, and engraved by Cousins, it may be said, *drawn by Light and engraved by Electricity.*"

VII. GALVANISM is intimately connected with electricity, though it is generally considered as a branch of Chemistry. It is only another mode of exciting electrical action. In electricity the effects are produced chiefly by *mechanical* action; but the effects of Galvanism are produced by the *chemical* action of bodies upon each other. If we take a piece of zinc, and place it under the

tongue, and lay a piece of silver, as big as a half-crown, above it; by bringing the outer edges of these pieces in contact, we shall immediately experience a peculiar and disagreeable taste, like that of copper. The same thing may be noticed with a guinea and a piece of charcoal. If a person, in the dark, put a slip of tinfoil upon one of his eyes, and a piece of silver in his mouth, by causing these pieces to communicate, a faint flash will appear before his eyes. If a living frog or a fish, having a slip of tinfoil pasted upon its back, be placed upon a piece of zinc, by forming a communication between the zinc and tinfoil, the spasms of the muscles are excited. These and similar effects are produced by that modification of electricity which has been termed *Galvanism*. Three different conductors, or what is called a *galvanic circle*, are requisite to produce such effects. A piece of copper, a piece of flannel, moistened with water or acid, and a piece of zinc, laid upon one another, form a circle; and if this circle be repeated a number of times, a galvanic pile or battery may be formed, capable of giving a powerful shock. The most common and convenient form, however, of a battery, is found to be a trough of baked wood, three or four inches deep, and as many wide. In the sides are grooves, opposite to each other, into each of which is placed a double metallic plate of zinc and copper soldered together, and the cells are then filled either with salt and water, or with a solution of nitrous acid and water.

By means of the galvanic agency, a variety of surprising effects have been produced. Gunpowder, cotton, and other inflammable substances have been inflamed—charcoal has been made to burn, with a most brilliant and beautiful white flame—water has been decomposed into its elementary parts—metals have been melted and set on fire—fragments of diamond, charcoal, and plumbago, have been dispersed, as if they had been evaporated—platina, the hardest and heaviest of the metals, has been melted as readily as wax in the flame of a candle—the sulphure, quartz, magnesio, lime, and the firmest compounds in nature, have been made to enter into fusion.—Its effects on the animal system are no less surprising. When applied to a fowl or a rabbit, immediately after life is extinct, it produces the most strange and violent convulsions on the nervous and muscular system, as if the vital functions were again revived; and when applied to the human body after death, the stimulus has produced the most horrible contortions and grimaces in the muscles of the head and face; and the most rapid movements in the hands and feet.

Numerous experiments which have been made both on dead animals and on human subjects, have led to the conclusion that galvanism possesses some *sanative* as well as energetic influence on the actions of diseased living beings. It has been found to effect cures, and to afford relief in nervous disorders. It has not only been used to cure the afflicted living, but also to resuscitate the apparently dead; and in all cases of suspended animation, from accidents or otherwise, it has been found to be a test of vitality, and the surest criterion of recent death. A celebrated medical writer on this subject, in Berlin, strongly recommends its use in rheumatism, palsy, nervous deafness, hoarseness, debility of sight, white swellings of the joints, tumors in the glands of the neck, and several other disorders. It is found that it possesses not only a stimulating power over the nerves and muscles, but also over the vital forces. M. Spronger, of Jena, gives an ac-

\* Nahm, i. 3-6.

count of his having restored the sense of hearing to 45 persons, by means of this singular agent—to four of whom he also restored the sense of smelling.—Galvanism has been lately employed as a powerful agent for blasting rocks. At Glasgow, and several other places, its agency has been applied with great success. At one blast hundreds of tons of stones have been in a moment loosened from the rock. It is found that dry sand is quite sufficient for filling the perforation in the rock where the charge is placed, and that the whole process is unaccompanied with the smallest degree of danger, so that, by this mode of blasting, those accidents which have so frequently happened to workmen employed in such operations may be entirely prevented.

The galvanic agency enables us to account for the following, among other facts:—Why porter has a different and more pleasant taste when drunk out of a pewter vessel than out of glass or earthenware,—why a silver spoon is discolored when used in eating eggs,—why the limbs of people, under amputation, are sometimes convulsed by the application of the instruments,—why pure mercury is oxidized when amalgamated with tin,—why works of metal, which are soldered together, soon tarnish in the places where the metals are joined,—and why the copper sheathing of ships, when fastened with iron nails, is soon corroded about the place of contact. In all these cases a galvanic circle is formed which produces the effects. We have reason to believe that, in combination with the discoveries which modern chemistry is daily unfolding, the agencies of this fluid will enable us to carry the arts forward toward perfection, and to trace the secret causes of some of the sublimest phenomena of nature.

VIII. MAGNETISM.—This department of philosophy describes the phenomena and the properties of the *loadstone*, or natural magnet. The natural magnet is a hard dark-colored mineral body, and is usually found in iron mines. The following are some of its characteristic properties:—1. It attracts iron and steel, and all substances which contain iron in its metallic state. 2. If a magnet be suspended by a thread, or nicely poised on a pivot, or placed on a piece of wood, and set to float in a basin of water, one end will constantly point nearly toward the north pole of the earth, and the other toward the south; and hence, these parts of the magnet have been called the *north* and *south poles*. 3. When the north pole of one magnet is presented near to the south pole of another, they will *attract* each other; but if the north pole of one be presented to the north pole of another, or a south pole to a south, they will *repel* each other. 4. A magnet placed in such a manner as to be entirely at liberty, inclines one of its poles to the horizon, and of course elevates the other above it. This property is called the *dipping* of the magnet. 5. Magnets do not point directly north and south; but in different parts of the world with a different *declination* eastward or westward of the north; it is also different at the same place at different times. In London, and in most places of Great Britain, the magnetic needle in 1824 pointed about 24 degrees to the west of the north. For more than 160 years previously it had been gradually declining from the north to the west; but seemed then to have begun its declination to the eastward. 6. Any magnet may be made to communicate the properties now mentioned to any piece of iron or steel. For example, by gently rubbing a penknife with a magnet, it will be immediately invested with the property of attracting needles, or small pieces of iron or steel.

7. Heat weakens the power of a magnet, and the gradual addition of weight increases the magnetic power. 8. The properties of the magnet are not affected either by the presence or the absence of air; and the magnetic attraction is not in the least diminished by the interposition of any bodies except iron. A magnet will equally affect the needle of a pocket compass, when a thick board is placed between them, as when it is removed. It has been lately discovered, that the *right rays of the solar spectrum*, when condensed with a convex glass, and made to pass along a piece of steel, have the power of communicating to it the magnetic virtue.

The cause which produces these singular properties of the magnet has hitherto remained a mystery; but the knowledge of the *polarity* of the magnet has been applied to a most important practical purpose. By means of it, man has now acquired the dominion of the ocean, and has learned to trace his course through the pathless deep to every region of the globe. There can be little doubt, that magnetism has an intimate connection with electricity, galvanism, light, heat, and chemical action; and the discoveries which have been already made, and others to be expected, from the experiments of Morichini, Oersted, Abraham, Hansteen, Barlow, Beaufoy, Ampère, and Scoresby, promise to throw some light on this mysterious agent, and on the phenomena of nature with which it is connected.

ELECTRO-MAGNETISM.—This is a new science founded on the connection which is now ascertained to subsist between Electricity and Magnetism. In the year 1819, Professor Oersted of Copenhagen discovered that, when a wire conducting electricity is placed parallel to a magnetic needle, properly suspended, the needle will deviate from its original or natural direction. 1. If the needle be *above* the conducting wire, and the positive electricity goes from right to left, the *north* end of the needle will be moved *from* the observer, or to the *west*. 2. If the needle is *below* the wire, and the electricity passes as before, the *north* end of the needle will be moved *toward* the observer or to the *east*. 3. If the needle is in the same horizontal plane with the wire, and is between the observer and the wire, the *north* end of it will be *elevated*. 4. If the needle is similarly placed on the opposite side, the north end of it will be *depressed*. From these facts M. Oersted concludes, that the magnetic action of the electrical current has a circular motion round the wire which conducts it.—When these experiments were commenced, and repeated, and varied by other philosophers, a multitude of new facts were soon brought to light through the labors of Davy, Faraday, Ampère, Barlow, Biot, and other experimenters. Two very important facts were ascertained by Ampère and Davy—that the conjunctive wire itself becomes a magnet—and that magnetic properties might be communicated to a steel needle not previously possessing them, by placing it in an electrical current. The former of these facts is proved by throwing iron filings on paper and bringing them under the wire, when they will immediately adhere to it, forming a tuft round it 10 or 12 times the diameter of the wire. On breaking the connection with the battery, however, they immediately fall off, proving that the magnetic effect depends entirely on the passage of the electricity through the wire. The degree of force of the magnetic property thus communicated to the uniting wire, is considered by Sir H. Davy, to be proportional to the quantity of electricity transmitted through it. Hence the

finer the wire the more powerfully magnetic was it rendered; and hence also a battery of very large plates was found to give the strongest magnetism to the wire connecting its poles.

The following are some of the results of experiments which have been made on this subject;—1. The deviation of the magnetized needle is greater or less, according to the nature of the conducting wire; and copper appears to be of all metals that which produces the most powerful effects. 2. The intensity of an electrical current is constant throughout the whole of a homogeneous wire whatever may be its length. 3. If two homogeneous conductors be *simultaneously* adapted to the same galvanic pile—first, the absolute intensity of the current decreases in the inverse ratio of the square root of the length of the wire—and secondly, when the thickness of the wires is altered, the intensity of the current increases with their diameter to a certain limit, beyond which an increase of thickness no longer produces any change in the intensity of the current. 4. When the conjunctive wires of two distinct galvanic arrangements are made to approach each other, magnetic attractions and repulsions are observed. Two wires of copper, silver, or any other metal, connecting the extremities of two galvanic troughs, being placed parallel to each other, and suspended so as to move freely, immediately attract and repel each other, according as the directions of the currents of electricity flowing through them are the same or different.—On this experiment is founded the most plausible and rational theory of magnetism, namely, that it arises from the attractions and repulsions of currents of electricity constantly circulating round every magnet. This is considered as explaining the reason why the magnetic needle places itself at right angles to a wire conducting electricity, namely, that the electric current passing along the wire may coincide with that circulating round the magnet.

These, and a great number of other facts, it is presumed, clearly demonstrate the perfect resemblance, or rather identity, of electricity and magnetism. Magnetic phenomena are thus, in fact, a series of electrical phenomena, and magnetism may, with propriety, form a branch of electricity, under the head of *Electrical currents*. Currents of electricity, according to this theory, are essential to the production of magnetic phenomena; but these are not obvious in a common magnet. M. Ampère has suggested their existence, however, and has so arranged them theoretically, as to account for a great proportion of magnetic appearances. A magnet, he conceives, to be an assemblage of as many electrical currents moving round it in planes perpendicular to its axis, as there may be imagined lines, which, without cutting one another, form closed curves round it. A permanent magnet, then, may be conceived to be a mass of iron or steel round the axis of which electric currents are continually circulating, and these currents attract all other electric currents flowing in the same direction, and repel all others which are moving in an opposite direction. One important circumstance is always to be kept in view, that the electric currents flow round every magnet in the same direction in reference to its poles. If, for instance, we place a magnet with its north pole pointing to the north, in the usual position of the magnetic needle, the current of electricity flows round it from west to east—or in the direction in which the planets revolve, and the earth on its axis—or on the western side of the magnet it is moving upward, and on the eastern side downward; on the upper side from west to east,

and on the lower side from east to west. This is ascertained to be a uniform law, and on these principles most of the phenomena of magnetism may be accounted for.

To complete the view of Ampère's doctrine on this point, it remains only to explain the influence of the earth on the magnet by which the needle is kept always in one position, nearly coinciding with the meridian. He maintains that currents of electricity, analogous to those which circulate round every magnet, are constantly floating round the globe, as the current of electricity in a galvanic apparatus moves in an unbroken circuit from the negative to the positive pole, and from it, by the connecting wire, round again to the negative pole. The direction of these currents he infers to be the same as has been stated with artificial magnets; and it is simply by the attractions and repulsions of these terrestrial currents, bringing the currents round the needle to coincide with them, that the latter always points to the north. The cause of these electric currents thus inferred to be constantly circulating round the globe, is, as yet, involved in obscurity. They are supposed to move at right angles to the magnetic meridian, or nearly parallel with the equator, on the eastern side of the earth moving from us, and on the western side flowing toward us. It is conjectured that the arrangement of the materials of the globe may be such as to constitute a battery, existing like a girdle round the earth, which, though composed of comparatively weak materials, may be sufficiently extensive to produce the effects of terrestrial magnetism. Its irregularity, and the changes it may accidentally or periodically suffer, may explain the phenomenon of the variation of the compass;—or the general action producing the currents of electricity may be affected by different causes, as the motions of the earth, the currents of the atmosphere, the process of evaporation, and the solar heat. It may also be supposed that much of the variation depends on the progress of oxydation in the continental regions of the globe.

In connection with the principles and phenomena stated above,—by means of a galvanic battery, iron may be temporarily magnetized—in other words, endowed with an attractive power, so long as it is kept in connection with the galvanic apparatus. A magnet of this kind is generally formed in the shape of a horse-shoe; and when suspended so as to present the extremities downward, and when the galvanic communication is established, the magnetic power is instantly exerted, and a bar of iron held to the extremities will be immediately attracted, and firmly adhere. But, on loosening the connection with the battery, the magnetic power is instantly destroyed, and the ball of iron falls to the ground. Such magnets, which have obtained the name of *Electro-magnets*, have been thus made, endowed with very great attractive power, so as to sustain, in some cases, a weight of above 2000 pounds, or nearly a ton. These magnets, like those which possess permanent magnetism, have opposite poles, one attracting, and the other repelling.

This new science of Electro-magnetism has opened up new and more expansive views to the philosophic world, in reference to the powers of Electricity, Galvanism, and Magnetism, and their relation to each other; and in the progress of the investigations which are now going forward, we have reason to hope that some of the hitherto latent principles which pervade our terrestrial system will be unfolded, and the diversified phenomena they produce more fully explained and illus-



trated. It is probable, too, that the arts will be improved by the application of the principles which this science has brought to light; and they have already been applied to machinery to produce rotatory and impulsive motions.

Such is a faint outline of some of the interesting subjects which Natural Philosophy embraces. Its relation to Religion will appear from the following considerations:—

1. Its researches have led to the invention of machines, engines, and instruments of various kinds, which augment the energies, increase the comforts, and promote the general improvement of mankind; and these objects are inseparably connected with the propagation of Christianity through the world. If we admit that, in future ages, the religion of the Bible will shed its benign influence over all nations—that the external condition of the human race will then be prosperous and greatly meliorated beyond what it has ever been—and, that no *miraculous interposition* of Deity is to be expected to bring about such desirable events—it will follow, that such objects can be accomplished only, in the ordinary course of Providence, by rational investigations into the principles and powers of Nature, and the application of the inventions of science to the great objects of religion, and of human improvement, as I shall endeavor briefly to illustrate in the following chapter. As the destructive effects of many physical agents, in the present constitution of our globe, are, doubtless, a consequence of the sin and depravity of man—we have reason to believe, that, when the economy of nature shall be more extensively and minutely investigated, and the minds of men directed to apply their discoveries to philanthropic and religious objects, they will be enabled to counteract, in a great measure, those devastations and fatal effects which are now produced by several of the powers of nature. The general happiness of all ranks, which will be connected with the universal extension of Christianity, necessarily supposes that this object will be accomplished; for, were a dread of destruction from the elements of nature frequently to agitate the mind, as at present, no permanent tranquillity would be enjoyed; nor would that ancient prediction in reference to this era, receive its full accomplishment, that “there shall be *nothing to hurt or destroy* in all God’s holy mountain, when the earth shall be full of the knowledge of the Lord.” And since miraculous interpositions are not to be expected, to what quarter can we look for those subordinate agencies by which this object is to be effected, but to the discoveries and inventions of philosophical science?

Science has already enabled us to remedy many of those evils which are the accidental effects of the operation of physical agents. For example—the discoveries of the philosopher, with respect to the nature of the electric fluid, have enabled us to construct conductors for preserving buildings from the stroke of lightning; and we have every reason to hope, that, in the progress of electric, galvanic, and chemical science, more complete thunder-guards, applicable to all the situations in which a person may be exposed, will be invented. Nay, our increasing knowledge of the electric fluid, and of the chemical agents which concur in its operation, may enable us to dissipate thunder-storms altogether, by disturbing the electricity of the clouds, by means of a series of elevated artificial conductors. This is not only possible, but has already been in some degree effected. The celebrated Euler informs us, in his “Letters to a German Princess,” that he corresponded with a

Moravian priest, named *Divisch*, who assured him, “that he had averted, during a whole summer, every thunder-storm which threatened his own habitation and the neighborhood, by means of a machine constructed on the principles of electricity—that the machinery sensibly attracted the clouds, and constrained them to descend quietly in a distillation, without any but a very distant thunderclap.” Euler assures us, that “the fact is undoubted, and confirmed by irresistible proof.” Yea, not only may the destructive effects of lightning be averted by the inventions of philosophy, but its agency may be rendered subservient to human industry, and made to act as a mechanical power. This effect, too, has been partially accomplished. About the year 1811, in the village of Philipsthal, in Eastern Prussia, an attempt was made to split an immense stone into a multitude of pieces, by means of lightning. A bar of iron, in the form of a conductor, was previously fixed to the stone, and the experiment was attended with the most complete success; for, during the very first thunder-storm, the lightning burst the stone without displacing it.\*

It is, therefore, probable that, in the future ages of the world, this terrific meteor, and other destructive agents, which now produce so much alarm, and so many disastrous effects, may, by the aid of philosophy, be brought under the control of man, and be made to minister to his enjoyment.

The electric fluid has also been, in many instances, successfully applied in curing palsies, rheumatisms, spasms, obstructions, and inflammation; and it is known to have a peculiar effect on the nervous system. Lightning has been known to restore the blind to a temporary enjoyment of sight. Mr. Campbell, of Sueoouth, in Dunbartonshire, who had been blind for several years, was led by his servant one evening through the streets of Glasgow, during a terrible thunder-storm. The lightning sometimes fluttered along the streets for a quarter of a minute without ceasing. While this fluttering lasted, Mr. Campbell saw the street distinctly, and the changes which had been made in that part by taking down one of the city gates. When the storm was over, his entire blindness returned.—The following instance, stated by Professor Robison, as related by one of his friends, is no less remarkable. One evening in autumn, he was sitting with a gentleman who had the same disorder as the gentleman mentioned above, and he observed several lumbent flashes of lightning. Their faces were turned to the parlor window; and immediately after a flash, the gentleman said to his wife, “Go, my dear, make them shut the white gate; it is open, you see.” The lady did so, and returned; and, after a little, said, “But how did you know that the gate was open?” He exclaimed, with wonder, “I saw it open, and two men look in, and go away again”—which our friend also had observed—the gentleman, on being close-questioned, could not recollect having had another glance, nor why it had not surprised him; but of the glimpse itself he was certain, and described the appearance very exactly.†

It is also possible, that barren deserts might be enriched with fertility, and immense portions of the desolate wastes of our globe prepared for the support and accommodation of human beings, by arresting the clouds, and drawing down their elec-

\* See Monthly Magazine, vol. xxii, p. 162.

† See, to Ency. Brit., 3d edit., Art. *Thunder*—written by the late Dr. K. Lison.

trical virtue and their watery treasure, by means of an extended series of elevated metallic conductors. What has been now stated, is only one instance out of many which might be produced, of the extensive and beneficial effects which may be produced, in future ages, by the application of the discoveries of natural science.

2. A knowledge of Natural Philosophy enables us to detect *pretended* miracles, and to discriminate between those phenomena which are produced by the powers of nature, and the supposed effects of diabolical influence. It has been chiefly owing to ignorance of the principles of natural science, that mankind, in all ages, have been so easily imposed upon by pretenders to supernatural powers. It is owing to the same cause, that superstitious notions and vain alarms have spread their influence so extensively among the lower ranks of the population of every country. The pretended miracles by which Pagan and Popish priests endeavor to support the authority of their respective religious systems, and every species of degrading superstition, vanish into smoke, when examined by the light of modern science; and there can be no question, that an enlightened Missionary would, in many instances, find the principles and the instruments of natural philosophy important auxiliaries in undermining the fabric of heathen idolatry and priestcraft. They tend to dissipate a thousand idle terrors which haunt and agitate the human mind; to detect a thousand kinds of imposture by which it has been held in cruel bondage; and to prevent the perpetration of those deeds of cruelty which have uniformly marked the reign of Superstition.\* Had our forefathers connected a knowledge of this subject with their study of the Scriptures, they would not have brought upon themselves that indelible disgrace which now attaches to their memories, on account of their having condemned and burned at the stake thousands of unhappy women, accused of crimes of which they could not possibly have been guilty.† In New England, toward the close of the 17th century, the witchcraft frenzy rose so high, that the execution of witches became a calamity more dreadful than the sword or the pestilence. Not only old women, but children of ten years, were put to death; young girls were stripped naked, and the marks of witchcraft searched for upon their bodies with most indecent curiosity; and those spots of the scurvy which age impresses upon the bodies of old men were taken for evident

signs of infernal power. So that ignorance of the laws and phenomena of nature has led even Christians to commit acts of injustice and horrid cruelty. For, let it be remembered that it was *Christian* magistrates and ministers, under a pretended zeal for the honor of God, who sanctioned such cruel and unrighteous decrees. This consideration, viewed in connection with many others, tends to show, that the Christian revelation, considered abstractly by itself, without a reference to the visible system of the universe, is not sufficient for all the purposes for which it was intended; as, on the other hand, the study of the works of nature is not sufficient of itself to lead the mind to the true knowledge of God, without the aid of the discoveries derived from the sacred oracles. For, although the Bible has been in the hands of Protestant Christians ever since the Reformation, yet it is only since the light of modern science began to diffuse its influence, that the superstitions of the dark ages, and the vulgar notions respecting witchcraft, necromancy, and other species of infernal agency, began to vanish, even from the minds of Christian teachers; as is evident from the writings of many eminent divines who flourished during the 16th and 17th centuries. As the two revelations which God has given throw a mutual luster on each other, the one must always be considered as incomplete without the other. Both are necessary, in order "to make the man of God perfect," and to enable him to prosecute, with intelligence and success, the great objects of religion; and the Christian minister who affects to despise the aids of science in the cause of religion has yet much to learn with respect to some of the grand bearings of the Christian system.

3. The investigations of natural philosophy unfold to us the incessant agency of God, and the plans by which his wise and benevolent designs in the system of nature are accomplished. From the immeasurable globes of heaven, down to the minutest atoms, we perceive a regular chain of causes and effects, conspiring, in a thousand different modes, to accomplish the purposes of infinite wisdom and goodness. The operation of central forces, and of the law of gravitation on the earth, and in the heavens—the hydrostatical laws which regulate the pressure and the motion of fluids—the chemical properties of the atmosphere, its undulatory, refractive, and reflective powers—the motion of the rays of light, and the infinite variety of effects they produce—the process of evaporation—the agencies of electricity and galvanism—the properties of the magnet, and the chemical action of acids and alkalies, and of the minutest particles of matter upon each other,—ought to be viewed as so many modifications of the agency of Deity, and as manifestations of his wisdom, in carrying forward those plans which regard the interests of his universal kingdom; just as we consider the rise and fall of empires, the revolutions of nations, and the circulation of the Scriptures in heathen lands, as so many acts of his moral administration as the Governor of mankind. For, let it be carefully remembered, that all these physical agencies have ultimately a moral and intellectual bearing; and are essentially connected with every other part of God's providential procedure. Though we may be apt to consider them as so many detached and insulated pieces of machinery, with which we have little concern, or may even disdain to notice their mode of operation; yet, in the all-comprehensive mind of Him who takes in, at one glance, the whole chain of causes and effects, they are as essentially con-

\* Mr. Douglas, in his "Hints on Missions," suggests, that Natural Philosophy might be an important auxiliary to Christian Missionaries. "All the ancient war weapons of victory," excepting miracles, are at their disposal; and new instruments of still greater potency, which the science of the latter days has been accumulating for universal revolution of the mind are ready to be brought into action, upon a scale of overpowering magnitude. Even the single resource which is lost may yet be recompensed by equivalents, and a substitute, in many respects, may be found for miracles. The first effect of a miracle is, to rouse the attention, and to overcome opposing prejudices; the second, to afford a proof of religion of which it is a sealing accompaniment.—*The first object might be gained by the natural magic of experimental philosophy*; and as to the second, the difference in the proof from miracles, lies rather in its being more circuitous, than in its being less conclusive at the present day, than in the times of the Apostles." Mr. Moffat, missionary from Africa, lately expressed to the author sentiments similar to the above, and intimated his ardent desire that he might be furnished, before his return, with an apparatus for the purpose of expanding the minds of heathen converts in the knowledge of nature.

† It has been calculated that, in *Germany alone*, the number of victims that suffered for the supposed crime of witchcraft from 1484—the date of the bull of Pope Innocent VIII, against witchcraft—until the beginning of the eighteenth century, considerably exceeds one hundred thousand!

nected with his ultimate purposes, and the eternal destiny of man, as are the revelations of his word.—Were a single principle or motion which now animates the system of nature to cease—were the agency of electricity, for example, or the principle of evaporation, to be destroyed—the physical constitution of our globe would instantly be deranged; nature would be thrown into confusion; and the sentient and intellectual beings that now inhabit the earth would either be destroyed, or plunged into a *abyss* of misery. If therefore we admit, that the *moral* agency of God is worthy of our contemplation, we ought to consider his physical operations also as no less worthy of our study and investigation; since they form the groundwork of all his other manifestations.

There is nothing, however, which so strikingly characterizes the bulk of mankind, and even the great mass of the Christian world, as that apathy and indifference with which they view the wonders of creation which surround them. They can look on all that is grand and beautiful and beneficent in nature, without feeling the least sentiment of admiration or of gratitude to that Being who is incessantly operating within them and around them; and they are disposed to consider the experiments of philosophers, by which the wonderful agency of God is unveiled, as only so many toys and amusements for the entertainment of children. They would prefer the paltry entertainments of a card-table, of a ball-room, or of a gossiping party, to the inspection of the nicest pieces of Divine mechanism, and to the contemplation of the most august scene in nature. However lightly some religionists may be disposed to treat this subject, that spirit of indifference with which the visible works of God are treated must be considered as flowing from the same *depraved principle*, which leads multitudes to reject the revelations of the Bible, and to trifle with their everlasting interests. “Man,” says Rollin, “lives in the midst of a world of which he is the sovereign, as a stranger, who looks with indifference upon all that passes in it, and as if it were not his concern. The universe, in all its parts, declares and points out its Author; but, for the most part, to the deaf and blind, who have neither ears to hear, nor eyes to see. One of the greatest services that philosophy can do us, is to awaken us from this drowsiness, and rouse us from this lethargy, which is a dishonor to humanity, and in a manner reduces us below the beasts, whose stupidity is the consequence of their nature, and not the effect of neglect or indifference. It awakens our curiosity, it excites our attention, and leads us, as it were, by the hand, through all the parts of nature, to induce us to study and search out the wonderful works of it.”\*

Since, therefore, the science of natural philosophy is conversant about the works of the Almighty, and its investigations have a direct tendency to illustrate the perfections of his nature, to unveil the plan of his operations, to unfold the laws by which he governs the kingdom of universal nature, and to display the order, symmetry, and proportion, which reign throughout the whole—it would be needless to enter into any further process of reasoning, to show that the study of it is connected with the great objects of religion.—Whatever studies tend to raise our minds to the Supreme Ruler of all worlds—to expand our views of his infinite knowledge and wisdom—to excite our gratitude and our admiration of the be-

neficent designs which appear in all his arrangements—to guard us against erroneous conceptions of his providential procedure—and to furnish us with important auxiliaries for extending the influence of his religion through the world—must always be interesting to every Christian who wishes to enlarge his intellectual views, and to make progress in the knowledge of God.

## CHEMISTRY.

This science, which is intimately related to the preceding, has for its object to ascertain the ingredients, or first principles, of which all matter is composed—to examine the compounds formed by the combination of these ingredients—to investigate those changes in natural bodies, which are not accompanied with *sensible* motion, and the nature of the power which produces these combinations and changes.

Within the limits of the last half century, the empire of Chemistry has been wonderfully extended. From an obscure and humble place among the objects of study, it has risen to a high and dignified station among those sciences which improve and adorn the human mind. No longer confined to the paltry and mercenary object of searching for the philosopher's stone, or of furnishing a little amusement, it now extends its sway over all the arts which minister to the comfort and improvement of social life, and over every species of animate and inanimate matter, within the range of human investigation. There is scarcely any science so immediately conducive to social improvement and human comfort. To whatever art or manufacture we turn our attention, we find that it has either been created by chemistry, or is indebted to its discoveries for some of its greatest improvements; and to whatever process in the material world we direct our investigations, the principles of this science, as deduced from modern experiments and discoveries, are capable of being applied. “The forms and appearances,” says Sir Humphrey Davy, “of the beings and substances of the external world, are almost infinitely various, and they are in a state of continued alteration. Even the earth itself, throughout its whole surface, undergoes modifications. Acted on by moisture and air, it affords the food of plants; an immense number of vegetable productions arise from apparently the same materials; these become the substance of animals; one species of animal matter is converted into another; the most perfect and beautiful of the forms of organized life ultimately decay, and are resolved into inorganic aggregates; and the same elementary substances, differently arranged, are contained in the inert soil; or bloom, and emit fragrance in the flower; or become, in animals, the active organs of mind and intelligence. In artificial operations, changes of the same order occur: substances having the characters of earth, are converted into metals; clays and sands are united, so as to become porcelain; earths and alkalies are combined into glass; acid and corrosive matters are formed from tasteless substances; colors are fixed upon stuffs; or changed, or made to disappear; and the productions of the vegetable, mineral, and animal kingdoms, are converted into new forms, and made subservient to the purposes of civilized life.—To trace, in detail, these diversified and complicated phenomena; to arrange them, and deduce general laws from their analogies, is the business of Chemistry.”\*

\* Belles Lettres, vol. iv.

\* Elements of Chemical Philosophy.

Chemists have arranged the *general forms of matter* into the four following classes:—The *first* class consists of SOLIDS, which form the principal parts of the globe, and which differ from each other in hardness, color, opacity, transparency, density, and other properties. The *second* class consists of fluids, such as water, oils, spirits, etc., whose parts possess freedom of motion, and require great mechanical force to make them occupy a smaller space. The *third* class comprehends ELASTIC FLUIDS, or GASES, which exist freely in the atmosphere; but may be confined by solids and fluids, and their properties examined. Their parts are highly movable, compressible, and expansive; they are all transparent; they present two or three varieties of color; and they differ greatly in density. The *fourth* class comprehends ETHEREAL SUBSTANCES, which are known to us only in their states of motion, when acting upon our organs of sense, and which are not susceptible of being confined. Such are the *rays of light*, and *radiant heat*, which are incessantly in motion, throughout the spaces that intervene between our globe, and the sun and the stars.—Chemists divide the substances in nature also into SIMPLE and COMPOUND. SIMPLE SUBSTANCES are those which have never yet been decomposed, nor formed by art. COMPOUND SUBSTANCES are those which are formed by the union of two or more simple substances. The following are all the *simple* substances with which we are at present acquainted: CALORIC, LIGHT, OXYGEN, NITROGEN, CARBON, HYDROGEN, SULPHUR, PHOSPHORUS, the METALS, and some of the EARTHS.—All that I propose under this article is simply to state some of the properties of two or three of these simple substances.

CALORIC, or elementary fire, is the name now given by chemists to that element or property which, combined with various bodies, produces the sensation of *heat* while it is passing from one body to another. This substance appears to pervade the whole system of nature. There are six different sources from whence Caloric may be procured. It may be produced by *combustion*, in which process the oxygen gas of the atmosphere is decomposed, and caloric, one of its component parts, set at liberty—by *friction*, or the rubbing of two substances against each other—by *percussion*, as the striking of steel against a piece of flint—by the *mixture of two or more substances*, as when sulphuric acid is poured upon water or magnesia—by *electricity and galvanism*. The discharge of an electric or galvanic battery, will produce a more intense degree of heat than any other means whatever. But the principal, and probably the original source of caloric, is the *Sun*, which furnishes the earth with a regular supply for the support and nourishment of the animal and vegetable tribes. From this source it moves at the rate of 192,000 miles in a second of time; for it has been already stated, that the sun sends forth rays of heat which are distinct from those which produce illumination, and which accompany them in their course through the ethereal regions.

Caloric is the cause of *fluidity*, in all substances which are capable of becoming fluid. A certain portion, or *dose* of it, reduces a solid body to the state of an incompressible fluid; a larger portion brings it to the state of an aeriform or gaseous fluid. Thus, a certain portion of caloric reduces ice to a state of water; a larger portion converts it into steam or vapor. There is reason to believe, that the hardest rocks, the densest metals, and every solid substance on the face of the earth,

might be converted into a fluid, and even into a gas, were they submitted to the action of a very high temperature. This substance is called *sensible caloric*, when it produces the sensation of *heat*; and *latent caloric*, when it forms an insensible part of the substance of bodies. One of the principal effects of caloric is the *expansion* of bodies. All bodies, with a very few exceptions, are capable of expansion by means of heat; the gases being the most expansive, and solids the least susceptible of expansion. The expansion of gases or any aeriform substance is illustrated by the experiment of a half-blown bladder held before a fire, as stated under the article *Pneumatics*, p. 94. The expansion of solids is illustrated by the following process: When the iron rim of a cart-wheel is to be put on, it is first heated to a considerable degree. When hot, the circle is somewhat larger than when cold, and thus easily slips round the wheel; but, as it cools, the circle decreases, and firmly binds together the wood-work of which the wheel is composed. In reference to *fluid* bodies the same fact is exemplified in the *Thermometer*—the mercury or spirit of wine in which rises or falls in proportion to the quantity of heat which is applied to the instrument.—Other effects of heat are *liquefaction*, as when ice is converted into water—*vaporization*, as when water is converted into steam—*ignition*, as when bodies by heat are made to produce flame—and *evaporation*, when substances send off vapor from their surfaces at temperatures below the boiling point. The heat of the sun and other causes produce this effect every day over the whole surface of the globe. An immense quantity of vapor is thus continually rising from the surface of the land and seas, which is either formed into clouds, or condensed into rains or dew— which process is of most essential service throughout the whole economy of the physical constitution of our globe.—All bodies are, in a greater or less degree, *conductors* of caloric. Metals and liquids are good conductors of heat; but silk, cotton wool, wood, etc., are bad conductors of it. For example, if we put a short poker into the fire at one end, it will soon become hot at the other; but this will not happen with a piece of wood of the same length, and under the same circumstances. A person with a silken purse, containing metal coin, may stand so near the fire, as to make the metal almost too hot to touch, though the temperature of the purse will apparently be scarcely altered. If a hand be put upon a hot body, part of the caloric leaves the hot body and enters the hand, producing the sensation of heat. On the contrary, if a hand be put on a cold body, as a piece of iron, or another colder hand, part of the caloric contained in the hand leaves it to unite with the colder body, producing the sensation of cold. In short, caloric is diffused throughout all bodies, and enters into every operation in nature; and, were it not for the influence of this subtle fluid, there is reason to believe that the whole matter of the universe would be condensed into a solid mass.

OXYGEN is a very pure, subtle, and elastic substance, generally diffused throughout nature; but is never found unless in combination with other substances. It is one of the most important agents in nature; there being scarcely a single process, whether natural or artificial, in which oxygen has not some important share. When combined with caloric it is called *oxygen gas*, which forms one of the constituent parts of the atmosphere. It is a permanently elastic fluid, transparent, colorless, and destitute of taste and smell; 100 cubic inches

of it weigh 33-9153 grains, that is, nearly 34 grains. And as the same bulk of common air weighs 30-8115 grains under the same circumstances, the specific gravity of oxygen is reckoned 1-1007, that of common air being reckoned 1-000, though some chemists have adopted 1-111 as its specific gravity compared with atmospheric air. In this state, it forms the principle of *combustion*: producing the most rapid de-lagration of all combustible substances. If a lighted taper be let down into a jar of oxygen gas, it burns with such splendor that the eye can scarcely bear the glare of light, and at the same time produces a much greater heat than when burning in common air. If a steel wire, or a thin file, having a sharp point, armed with a piece of wood in inflammation, be introduced into a jar filled with this gas, the steel will take fire, and its combustion will continue producing a most brilliant phenomenon. It has been proved, by numerous experiments, that this gas is so *essential* to combustion, that no substance will burn in common air which has been previously deprived of its oxygen. It is also essential to the support of animal life; so that man, and all the inferior ranks of animated nature, may be said to depend upon this fluid for their existence. Its basis gives the *acid* character to all mineral and vegetable salts; and the *calcination* of metals is altogether effected by their union with oxygen. It constitutes the basis both of the atmosphere which surrounds the earth, and of the water which forms its rivers, seas, and oceans. It pervades the substance of all the vegetable tribes, and enables them to perform their functions; and, in combination with the different metals, serves the most important purposes in the useful arts. In the operation of this elementary principle, we perceive a striking display of the agency of the Creator, and of the admirable means which his wisdom has contrived for preserving in due order the system of nature. And as this wonderful substance is so essentially necessary to animal and vegetable existence, everything is so arranged as to produce a regular supply of it, notwithstanding its incessant changes, and the multifarious combinations into which it is continually entering.

One of the most extraordinary effects of oxygen appears, when it is combined, in a certain proportion, with nitrogen, so as to form the gaseous oxide of nitrogen, or what is commonly called *nitrous oxide*. This gas consists of 63 parts nitrogen, and 37 oxygen, by weight. When inhaled into the lungs, it produces an extraordinary elevation of the animal spirits, a propensity to leaping and running, involuntary fits of laughter, a rapid flow of vivid ideas, and a thousand delightful emotions, without being accompanied with any subsequent feelings of debility. This circumstance shows what a variety of delightful or pernicious effects might flow from the slightest change in the constitution of the atmosphere, were the hand of the Almighty to interpose in altering the proportion of its constituent parts; for atmospheric air is composed of 79 parts of nitrogen, and 21 of oxygen, which is not a very different proportion from the above. Another gas, called *nitric oxide*, composed of 56 parts oxygen, and 44 nitrogen, produces instant suffocation in all animals that attempt to breathe it. One of the most corrosive acids, the *nitrous acid*, or aquafortis, is composed of 75 parts oxygen, and 25 parts nitrogen; so that we are every moment breathing a certain substance, which, in another combination, would produce the most dreadful pain, and cause our immediate destruction. What

a striking proof does this afford of the infinite comprehension of the Divine Mind, in foreseeing all the consequences of the elements of nature, and in directing their numerous combinations in such a manner as to promote the happiness of animated beings!

NITROGEN, or *azote*, is a substance generally diffused throughout nature, and particularly in animal bodies. It is not to be found in a solid or liquid state, but, combined with caloric, it forms *nitrogen gas*, which is one of the ingredients of the atmosphere. It enters extensively into combination with various substances; it is an abundant element in animal matter; and its existence in such large quantity is a chief distinction between the constitution of the substances which compose animal and vegetable matter. Its specific gravity is 0-9748, which is lighter than common atmospheric air, and therefore ascends in it. Were it heavier it would accumulate to such a degree in our apartments as to be pernicious and even destructive to our health and existence. It is incapable of supporting either flame or animal life. This is proved by introducing an animal, or a burning candle, into a vessel full of this gas; in which case, the animal is suddenly suffocated, and the candle instantly extinguished. It is this gas which is expelled from the lungs at every expiration, and rising over our heads, soon enters into new combinations. Though it is destructive to animal life, it appears to be favorable to plants, which vegetate freely when surrounded with nitrogen.

HYDROGEN is another elementary substance, abundant in nature, and, when united to caloric, forms *hydrogen gas*. It is one of the constituent parts of *water*; for it has been completely demonstrated by experiment, that water is composed of 85 parts by weight of oxygen, and 15 of hydrogen, in every hundred parts of the fluid. This gas was formerly known by the name of *inflammable air*. It is distinguished among miners by the name of *fire-damp*; it abounds in coal-mines, and sometimes produces the most tremendous explosions.\* It is incapable of itself of supporting combustion, and cannot be breathed without the most imminent danger. It is the chief constituent of oils, fats, spirits, ether, coals, and bitumen; and is supposed to be one of the agents which produce the *ignes fatui*, and the *northern lights*. It is the *lightest* of all ponderable bodies, being from twelve to fifteen times lighter than common air. A hundred cubic inches of it weigh about 2 $\frac{1}{4}$  grains. On account of its great levity, it is used for filling *air balloons*. In contact with atmospheric air, it burns with a pale blue color. When mixed with oxygen gas, it may be exploded, like gunpowder, with a violent report. *Carburetted hydrogen gas*, which is *carbon* dissolved by hydrogen, is that beautiful gas which is now employed in lighting our streets, shops, and manufactories.

\* It appears from the First Report of the "Children's Employment Commission," appointed by Parliament in 1842, that, at the very least, 1500 lives have been sacrificed in and about the Tyne and Wear collieries in the neighborhood of Newcastle within the last 40 years, chiefly by the explosions of hydrogen gas which have taken place in the coal-mines. To counteract such effects, Sir H. Davy, in 1815, displayed his ingenuity by the invention of his *Safety Lamp*—which is made of wire gauze, and has this particular property, that the miner may move about with it, and even work by its light in the midst of those explosive mixtures which have so often proved fatal, when entered with a common lamp or candle. But the want of accuracy in some of the manufacturers of the gauze with which the instrument is constructed—and the carelessness of the miners in using it—have frequently prevented its beneficial effects from being realized. For a particular description of this lamp, see "Diffusion of Knowledge," Secs. II, V, and the Appendix.

CARBON is another simple substance extensively diffused throughout nature. It is found pure and solid only in the *diamond*; but it may be procured in the state of *charcoal*, by burning a piece of wood, closely covered with sand, in a crucible. Carbon enters into the composition of bitumen and pit coal, and of most animal and some mineral substances; and it forms nearly the whole of the solid basis of all vegetables, from the most delicate flower to the stately oak. It is also a component part of sugar, and of all kinds of wax, oils, gums, and resins. It combines with iron in various proportions, and the results are, cast-iron and steel. Black lead is a composition of nine-parts of carbon to one of iron; and is therefore called a *carburet* of iron. Carbon is *indestructible* by age, and preserves its identity in all the combinations into which it enters—*Carbonic acid gas* is a combination of carbon and oxygen. It is found in a state of combination with lime, forming limestone, marble, and chalk; and may be separated from them by heat, or by means of the mineral acids. This gas, which was formerly called *fixed air*, is found in mines, caves, the bottoms of wells, wine cellars, brewers' vats, and in the neighborhood of limekilns. It is known to miners by the name of *choke-damp*, and too frequently runs on deadly errands. It extinguishes flame and animal life. It is the heaviest of all the gases; being nearly twice the weight of common air, and twenty times the weight of hydrogen. It may therefore be poured from one vessel to another; and a lighted taper is instantly extinguished by pouring a small quantity of it over the flame. It is a powerful *antiseptic*, or preserver from putrefaction. Meat which has been sealed up in it (says Mr. Parkes), has been known to have preserved its texture and appearance for more than twenty years. There is no substance of more importance in civilized life than the different forms of *Carbon*. "In nature," says Sir H. Davy, "this element is constantly active in an important series of operations. It is evolved in fermentation and combustion, in Carbonic acid; it is separated from oxygen in the organs of plants; it is a principal element in animal structures; and is found in different forms in almost all the products of organized beings."

CHLORINE is a gas of a greenish color. It is fatal to animal life, if breathed undiluted with common air, but it does not, like nitrogen and carbonic acid gas, extinguish combustion. A candle burns in it with a red flame; and it possesses the remarkable property of setting fire to many of the metals, even at the common temperature of the air, when introduced into it beaten out into thin leaves or reduced to filings—such as copper, tin, arsenic, zinc, and antimony. It has the property of destroying all vegetable colors. If a vegetable *blue*, for instance, be exposed to its action, the color is not changed to a *red*, as it would be by an acid,—nor to a green, as it would be by an alkali,—but it is totally destroyed. On this account Chlorine has been introduced as a powerful agent in the art of bleaching; for if unbleached lincus be properly exposed to its action, the matter which gives them their gray color is destroyed. But if applied in its pure state, and not sufficiently diluted, it invariably destroys the strength and texture of the lincus. The specific gravity of this gas, when free from watery vapor is 2.5, common air being 1, and 100 cubic inches of it weigh about 77 grains.

IOURIC is the name of an undecomposed principle or element in chemistry. It remained undiscovered until 1812, when a manufacturer

of saltpeter in Paris detected it in the ashes of sea weeds. It resembles chlorine in some of its properties, and is derived from a source which also supplies chlorine, both of them being of marine origin. It may be procured by drying and powdering common sea weed, and heating it with sulphuric acid. A *violet-colored* vapor rises, which, if received in a cool vessel, will condense on its sides, and will form scaly crystals of a somewhat metallic luster. These crystals are the substance in question; and from the violet color of its vapor it is called *iodine*. Its specific gravity is 3.084; it melts at a heat a little above that of boiling water; at the temperature of 350° it boils and evaporates in a violet-colored vapor. It stains the fingers yellow, and consumes the cork of the vial in which it is contained. Its smell is disagreeable, its taste acrid, it destroys vegetable colors, and it possesses poisonous properties. It has the property of forming a beautiful blue color, when mixed with a little powdered starch, and diffused through cold water; and hence iodine and starch are used by chemists as mutual tests of each other's presence, even in the most minute quantity.

SULPHUR is a substance which has been known from the earliest ages. It was used by the ancients in medicine, and its fumes have, for more than 2000 years, been employed in bleaching wool. It is found combined with many mineral substances, as arsenic, antimony, copper, and most of the metallic ores. It exists in many mineral waters, and in combination with vegetable and animal matters, but is most abundant in volcanic countries, particularly in the neighborhood of Vesuvius, Etna, and Hecla in Iceland. It is a solid, opaque, combustible substance, of a pale yellow color, very brittle, and almost without taste or smell. Its specific gravity is nearly twice that of water: it is a non-conductor of electricity, and, of course, becomes electric by friction. When heated to the temperature of 170° of Fahrenheit's thermometer, it rises up in the form of a fine powder, which is easily collected in a proper vessel, and is named the *flowers of sulphur*. It is insoluble in water, but may be dissolved in oils, in spirit of wine, and in hydrogen gas. When sulphur is heated to the temperature of 302° in the open air, it takes fire spontaneously and burns with a pale blue flame, and emits a great quantity of fumes of a strong suffocating odor. When heated to the temperature of 570°, it burns with a bright white flame, and emits a vast quantity of fumes. When these fumes are collected, they are found to consist entirely of *sulphuric acid*; so that sulphur, by combustion, is converted into an *acid*. It is the base of several compound substances. It unites with oxygen, hydrogen, nitrogen, phosphorus, the alkalis, the metals, and some of the earths. This substance is of great importance in medicine, as it is found to penetrate to the extremities of the most minute vessels, and to impregnate all the secretions. It is also used in the arts, particularly in bleaching and dyeing; it forms a very large proportion of gunpowder; and one of its most common but not least useful properties, is that of its *combustibility*, by which, with the help of a tinder-box, light is almost instantaneously produced. As this substance has not yet been decomposed, it is considered by chemists, in the meantime, as one of the simple substances.

PHOSPHORUS is another simple combustible substance, but is never found in a pure state in nature. It is commonly united to oxygen in the state of phosphoric acid, which is found in differ-

ent animal, vegetable, and mineral substances. It was first discovered by Brandt, a chemist of Hamburg, in the year 1667, and afterward by the Honorable Mr. Boyle, in 1679. It was formerly obtained by a disgusting process; but is now extracted from the bones of animals, by burning them, and then reducing them to a fine powder, and afterward pouring sulphuric acid upon them. This substance, when pure, resembles bees' wax, being of a clear, transparent, yellowish color; it is insoluble in water; it may be cut with a knife, or twisted to pieces with the fingers; and it is about double the specific gravity of water. Its most remarkable property is its very strong attraction for oxygen, from which circumstance it burns spontaneously in the open air at the temperature of  $43^{\circ}$ ; that is, it attracts the oxygen gas from the atmosphere, and heat and flame are produced. It gradually consumes when exposed to the common temperature of air, emits a whitish smoke, and is luminous in the dark; for this reason it is kept in vials of water; and as the heat of the hand is sufficient to inflame it, it should seldom be handled except under water. At the temperature of  $99^{\circ}$  it melts; it evaporates at  $219^{\circ}$ , and boils at  $554^{\circ}$ . When heated to  $148^{\circ}$  it takes fire, and burns with a very bright flame, and gives out a large quantity of white smoke, which is luminous in the dark: at the same time it emits an odor, which has some resemblance to that of garlic; and this smoke, when collected, is proved to be an *acid*. It burns with the greatest splendor in oxygen gas, and, when taken internally, it is found to be poisonous. If any light substance, capable of conducting heat, be placed upon the surface of boiling water, and a bit of phosphorus be laid upon it, the heat of the water will be sufficient to set the phosphorus on fire. If we write a few words on paper, with a bit of phosphorus fixed in a quill, when the writing is carried into a dark room it will appear beautifully luminous. If a piece of phosphorus, about the size of a pea, be dropped into a tumbler of hot water, and a stream of oxygen gas forced directly upon it, it will under water display the most brilliant combustion that can be imagined. All experiments with phosphorus, however, require to be performed with *great caution*. This substance is used in making phosphoric match-bottles, phosphoric oil, phosphoric tapers, and various phosphoric fire-works. *Phosphorized hydrogen gas* is produced by bits of phosphorus remaining some hours in hydrogen gas. It is supposed to be that gas which is seen hovering on the surface of burial-ground's and marshes, known in Scotland by the name of *spunkie*, and in England by that of *will-o'-the-wisp*.

Some animals, as the *glow-worm* and the *fire-fly*, and fish in a putrescent state, exhibit phosphorescent qualities. M. Peron describes a singular instance of this kind in an animal which he calls the *pyrosoma atlanticum*, which he observed in his voyage from Europe to the Isle of France. The darkness was intense when it was first discovered; and all at once there appeared at some distance, as it were, a vast sheet of phosphorus floating on the waves, which occupied a great space before the vessel. When the vessel had passed through this inflated part of the sea, it was found, that this prodigious light was occasioned by an immense number of small animals, which swam at different depths, and appeared to assume various forms. Those which were deepest looked like great red-hot cannon balls, while those on the surface resembled cylinders of red-hot iron. Some of them were caught, and were found to vary in

size from three to seven inches. All the exterior surface of the animal was bristled with thick oblong tubercles, shining like so many diamonds; and these seemed to be the principal seat of its wonderful phosphorescence.

Such is a brief description of the principal elementary substances, which, in a thousand diversified forms, pervade the system of nature, and produce all that variety which we behold in the atmosphere, the waters, the earth, and the various processes of the arts. It is probable that some of these substances are compounds, though they have not yet been decomposed. Yea, it is possible, and not at all improbable, that there are but two, or at most three elementary substances in nature, the various modifications of which produce all the beauties and sublimities in the universe. Perhaps caloric, oxygen, and hydrogen, may ultimately be found to constitute all the elementary principles of nature.—Without prosecuting this subject further, I shall conclude this article with a few cursory reflections, tending to illustrate its connection with religion.

The remarks which I have already thrown out in reference to Natural Philosophy will equally apply to the science of Chemistry; and therefore do not require to be repeated. In addition to these, the following observations may be stated:—

1. This science displays, in a striking point of view, the wisdom and goodness of God, in *producing, by the most simple means, the most astonishing and benevolent effects*. All the varied phenomena we perceive throughout the whole system of sublunary nature are produced by a combination of six or seven simple substances. I formerly adverted to the infinite variety which exists in the vegetable kingdom.\* About 56,000 different species of plants have already been discovered by botanists. All these, from the humble shrub to the cedar of Lebanon, which adorn the surface of the globe, in every clime, with such a diversity of forms, shades, and colors, are the result of the combinations of “four or five natural substances—caloric, light, water, air, and carbon.” “When we consider,” says Mr. Parkes, “that the many thousand tribes of vegetables are not only all formed from a few simple substances, but that they all enjoy the same sun, vegetate in the same medium, and are supplied with the same nutriment, we cannot but be struck with the rich economy of nature, and are almost induced to doubt the evidence of those senses with which the God of nature has furnished us. That it should be possible so to modify and intermingle a few simple substances, and thence produce all the variety of form, color, odor, etc., which is observable in the different families of vegetables, is a phenomenon too astonishing for our comprehension.—Nothing short of Omnipotence could have provided such a paradise for man.”†

“Soft roll your incense, herbs and fruits and flowers,  
In mingled clouds, to Him whose sun exalts,  
Whose breath perfumes you, and whose pencil paints.”  
THOMSON.

What an admirable view is here opened up of the economy of Divine wisdom, and of the beneficent care which has been taken to secure the comfort and happiness of every living creature; and how ungrateful a disposition must it indicate in rational beings to overlook such benevolent arrangements! It is highly probable, that, in all the other worlds dispersed throughout the universe,

\* See p. 24.

† Chemical Catechism, chap. ix.

an infinite diversity of scenery exists, and that no one globe or system exactly resembles another; and yet it is probable, that the primary elements of matter, or the few *simple substances* of which our world is composed, may be of the same nature as those which form the constituent parts of every other system; and may give birth to all the variety which exists throughout the wide extent of creation, and to all the changes and revolutions through which the different systems may pass, during every period of infinite duration.

2. From this science we have every reason to conclude that matter is indestructible. In the various changes that take place in material substances, the particles of matter are not destroyed, but only assume new forms, and enter into new combinations. When a piece of wood, for example, is burned to ashes, none of its principles are destroyed; the elementary substances of which it was composed are only separated from one another, and formed into new compounds. Carbon, as already stated, appears to be indestructible by age, and to preserve its essential properties, in every mode of its existence. That Being, indeed, who created matter at first, may reduce it to nothing when he pleases; but it is highly improbable that his power will ever be interposed to produce this effect; or that any particle of matter which now exists, will ever be annihilated, into whatever new or varied combinations it may enter. When any particular world, or assemblage of material existence, has remained in its original state for a certain period of duration, and accomplished all the ends it was intended to subservise in that state, the materials of which it is composed will, in all probability, be employed for erecting a new system, and establishing a new series of events, in which new scenes, and new beauties and sublimities will arise from new and varied combinations. For the Creator does nothing in vain. But to annihilate, and again to create, would be operating in vain; and we uniformly find, that in all the arrangements of Deity, in the present state of things, Nature is frugal and economical in all her proceedings; so that there is no process, when thoroughly investigated, that appears unnecessary or superfluous.

From the fact, that matter appears to be indestructible, we may learn, that the Creator, with the self-same materials which now exist around us, may, after the general conflagration, new-model and arrange the globe we inhabit, so as to make a more glorious world to rise out of its ashes; purified from those physical evils which now exist; and fitted for the accommodation either of renovated men, or of other pure intelligences. From the same fact combined with the consideration of the infinite diversity of effects which the simple substances of nature are capable of producing, we may be enabled to form a conception of the ease with which the Creator may new-model our bodies, after they have been dissolved in the dust; and how, from the same original atoms, he may construct and adorn them with more glorious forms, and more delightful and exquisite senses than they now possess.

In short, the rapid progress which chemical science is now making, promises, ere long, to introduce improvements among the human race, which will expand their views of the agency of God, counteract many physical evils, and promote, to an extent which has never yet been experienced, their social and domestic enjoyment.—The late discoveries of Chemistry tend to convince us, that the properties and powers of natural substances are only beginning to be discovered.

Who could have imagined, a century ago, that an invisible substance is contained in a piece of coal, capable of producing the most beautiful and splendid illumination—that this substance may be conveyed, in a few moments, through pipes of several miles in length—and that a city, containing several hundred thousands of inhabitants, may be instantly lighted up by it, without the aid of either wax, oil, or tallow? Who could have imagined that one of the ingredients of the air we breathe is the principle of combustion—that a rod of iron may be made to burn in it with a brilliancy that dazzles the eyes—that a piece of charcoal may be made to burn with a white and splendid light, which is inferior only to the solar rays—and that the *diamond* is nothing more than *carbon* in a crystallized state, and differs only in a slight degree from a bit of common charcoal?—Who could have surmised, that a substance would be discovered, of such a degree of levity, as would have power sufficient to buoy up a number of men to the upper parts of the atmosphere, and enable them to swim, in safety, above the region of the clouds? These are only specimens of still more brilliant discoveries which will, doubtless, be brought to light by the researches of future generations. We have reason to believe, that the investigations of this science will in due time, enable us to counteract most of the diseases incident to the human frame; and to prevent many of those fatal accidents to which mankind are now exposed. Davy's *safety lamp* has already preserved many individuals from destruction, when working in coal mines; and thousands, in after ages, will be indebted to this discovery, for security from the dreadful explosions of hydrogen gas. And, we trust, that the period is not far distant, when specific antidotes to the diseases peculiar to the different trades and occupations in which mankind are employed will be discovered; and the health and vigor of the mass of society be preserved unimpaired, amidst all the processes in which they may be engaged.

In fine, the rapid progress of chemical discovery carries forward our views to a period, when man, having thoroughly explored the powers of nature, and subjected them, in some measure, to his control, will be enabled to ward off most of those physical evils with which he is now annoyed, and to raise himself, in some degree, to the dignity and happiness he enjoyed before moral evil had shed its baleful influence on our terrestrial system. Such a period corresponds to many of the descriptions contained in the Sacred Oracles of the millennial state of the church: when social, domestic, moral, and intellectual improvement shall be carried to the utmost perfection which our sublimity station will permit; when wars shall cease; when the knowledge of Jehovah shall cover the earth; when every man shall sit under his vine and fig-tree, without being exposed to the least alarm; and when there shall be no thing to hurt nor destroy throughout the church of the living God. And, therefore, we ought to consider the various discoveries and improvements now going forward in this, and other departments of science, as preparing the way for the introduction of this long-expected and auspicious era.

#### ANATOMY AND PHYSIOLOGY.

The general object of both these sciences is, to investigate and describe the structure and economy of the animal frame.—*Anatomy* dissects *dead* bodies. *Physiology* investigates the functions of



those that are *living*. The former examines the fluids, muscles, viscera, and all the other parts of the human body, in a state of *rest*; the latter considers them in a state of *action*.

The parts of the human body have been distinguished into two different kinds—solids and fluids. The solid parts are, *bones, cartilages, ligaments, muscles, tendons, membranes, nerves, arteries, veins, hair, nails, and ducts*, or fine tubular vessels of various kinds. Of these solid parts, the following compound organs consist: the *brain and cerebellum, the lungs, the heart, the stomach, the liver, the spleen, the pancreas, the glands, the kidneys, the intestines, the mesentery, the larynx*, and the organs of sense—the *eyes, ears, nose, and tongue*. The fluid parts are, the *saliva, or spittle, phlegm, serum, the chyle, blood, bile, milk, lymph, urine, the pancreatic juice, and the aqueous humor* of the eyes. The human body is divided into three great cavities—the *head; the thorax, or breast; and the abdomen, or belly*. The *head* is formed of the bones of the cranium, and incloses the brain and cerebellum. The *thorax* is composed of the vertebræ of the back, the sternum, and true ribs; and contains the *heart, the pericardium, the breasts, and the lungs*. The *abdomen* is separated from the thorax by means of the *diaphragm*, which is a fleshy and membranous substance, composed for the most part of muscular fibers. This cavity is formed by the lumbar vertebræ, the os sacrum, the ossa innominata, the false ribs, the peritoneum, and a variety of muscles. It incloses the stomach, intestines, omentum, or caul, the liver, pancreas, spleen, kidneys, and urinary bladder.—Without attempting any technical description of these different parts, which could convey no accurate ideas to a general reader, I shall merely state two or three facts in relation to the system of bones, muscles, and blood-vessels, as *specimens* of the wonderful structure of our bodily frame.

The *BONES* may be regarded as the propwork or basis on which the human body is constructed. They bear the same relation to the animal system, as the woodwork to a building. They give shape and firmness to the body; they support its various parts, and prevent it from sinking by its own weight; they serve as levers for the muscles to act upon, and to defend the brain, the heart, the lungs, and other vital parts from external injury. Of the bones, some are *hollow*, and filled with marrow; others are *solid* throughout; some are very *small*; others very *large*; some are *round*, and others *flat*; some are *plane*, and others *convex* or *concave*;—and all these several forms are requisite for the situations they occupy, and the respective functions they have to perform.—The *spine*, or back-bone, consists of 24 vertebræ, or small bones, connected together by cartilages, articulations, and ligaments; of which 7 belong to the neck, 12 to the back, and 5 to the loins. In the center of each vertebra, there is a hole for the lodgment and continuation of the spinal marrow, which extends from the brain to the rump. From these vertebræ the arched bones called *ribs* proceed; and seven of them join the breast-bone on each side, where they terminate in cartilages, and form the cavity of the thorax or chest. The five lower ribs, with a number of muscles, form the cavity of the abdomen, as above stated. The spine is one of the most admirable mechanical contrivances in the human frame. Had it consisted of only three or four bones, or had the holes in each bone not exactly corresponded, and fitted into each other, the spinal marrow would have been bruised, and life endangered at every bend-

ing of the body. The skull is composed of 10 bones, and about 51 are reckoned to belong to the face, the orbits of the eyes, and the jaws in which the teeth are fixed. There are seldom more than 16 teeth in each jaw, or 32 in all.—The number of bones in a human body is generally estimated at about 245; of which there are reckoned, in the skull, head, and face, 61; in the trunk, 64; in the arms and hands, 60; and in the legs and feet, 60. The bones are provided with *ligaments*, or hinges, which bind and fasten them together, and prevent them from being displaced by any violent motion; and, that the ligaments may work smoothly into one another, the joints are separated by *cartilages*, or gristles, and provided with a gland for the secretion of oil, or *mucus*, which is constantly exuding into the joints; so that every requisite is provided by our Benevolent Creator, to prevent pain, and to promote facility of motion. “In considering the joints,” says Dr. Puley, “there is nothing, perhaps, which ought to move our gratitude more than the reflection, *how well they wear*. A limb shall swing upon its hinge, or play in its socket, many hundred times in an hour, for sixty years together, without diminution of agility; which is a long time for anything to last, for anything so much worked as the joints are.”

The MUSCULAR SYSTEM.—A *muscle* is a bundle of fleshy, and sometimes of tendinous fibers. The fleshy fibers compose the body of the muscle; and the tendinous fibers the extremities. Some muscles are long and round; some plain and circular; some have *spiral*, and some have *straight* fibers. Some are double, having a tendon running through the body from head to tail; some have two or more tendinous branches running through, with various rows and orders of fibers. All these, and several other varieties, are essentially requisite for the respective offices they have to perform in the animal system. The muscles constitute the fleshy part of the human body, and give it that varied and beautiful form we observe over all its surface. But their principal design is, to serve as the *organs of motion*. They are inserted, by strong tendinous extremities, into the different bones of which the skeleton is composed; and by their contraction and distention, give rise to all the movements of the body. The muscles, therefore, may be considered as so many cords attached to the bones; and the Author of Nature has fixed them according to the most perfect principles of mechanism, so as to produce the fittest motions in the parts for the movements of which they are intended.

One of the most wonderful properties of the muscles is, the *extraordinary force* they exert, although they are composed of such slender threads, or fibers. The following facts in relation to this point, are demonstrated by the celebrated *Borelli*, in his work, “*De Motu Animalium*.” When a man lifts up with his teeth a weight of 200 pounds with a rope fastened to the jaw-teeth, the muscles named *Temporalis* and *Masseter*, with which people chew, and which perform this work, exert a force of above 15,000 pounds weight. If any one hanging his arm directly downward, lifts a weight of 20 pounds, with the third or last joint of his thumb, the muscle which bends the thumb, and bears that weight, exerts a force of about *three thousand pounds*. When a man, standing upon his feet, leaps or springs upward to the height of two feet, if the weight of such a man be 150 pounds, the muscles employed in that action will exert a force 2000 times greater; that is to say, a force of about *three hundred thousand pounds*. The *heart*, at each pulse or contraction, by which

it protrudes the blood out of the arteries into the veins, exerts a force of above a *hundred thousand pounds*. Who can contemplate this amazing strength of the muscular system, without admiration of the power and wisdom of the Creator, who has infused a bundle of threads, each of them smaller than a hair, with such an astonishing degree of mechanical force! There have been reckoned about 446 muscles in the human body, which have been dissected and distinctly described; every one of which is essential to the performance of some one motion or other, which contributes to our ease and enjoyment; and, in most instances, a great number of them is required to perform their different functions at the same time. It has been calculated, that about a *hundred muscles* are employed every time we breathe.—“Breathing with ease,” says Dr. Paley, “is a blessing of every moment; yet, of all others, it is that which we possess with the least consciousness. A man in an asthma is the only man who knows how to estimate it.”

**THE HEART AND BLOOD-VESSELS.**—The heart is a hollow muscular organ, of a conical shape, and consists of four distinct cavities. The two largest are called *ventricles*, and the two smallest *auricles*. The ventricles *send out* the blood to the arteries; the auricles *receive* it from the veins. The heart is inclosed in the *pericardium*, a membranous bag, which contains a quantity of water or lymph. This water lubricates the heart, and facilitates all its motions. The heart is the general reservoir of the blood. When the heart contracts, the blood is propelled from the *right ventricle* into the lungs, through the pulmonary arteries, which, like all the other arteries, are furnished with *valves* that play easily forward, but admit not the blood to return toward the heart. The blood, after circulating through the lungs, and having there been revived by coming in contact with the air, and imbibing a portion of its oxygen, returns into the *left auricle* of the heart, by the pulmonary vein. At the same instant, the *left ventricle* drives the blood into the *aorta*, a large artery which sends off branches to supply the head and arms. Another large branch of the aorta descends along the inside of the backbone, and detaches numerous ramifications to nourish the bowels and inferior extremities. After serving the most remote extremities of the body, the arteries are converted into *veins*, which, in their return to the heart, gradually unite into larger branches, until the whole terminate in one great trunk, called the *vena cava*, which discharges itself into the *right auricle* of the heart, and completes the circulation. Each ventricle of the heart is reckoned to contain about one ounce, or two table spoonful of blood. The heart contracts 4000 times every hour; and, consequently, there passes through it 250 pounds of blood in one hour. And if the mass of blood in a human body be reckoned at an average at twenty-five pounds, it will follow, that *the whole mass of blood passes through the heart*, and consequently through the thousands of ramifications of the veins and arteries, *ten times every hour*, or about once every six minutes. We may acquire a rude idea of the force with which the blood is impelled from the heart, by considering the velocity with which water issues from a syringe, or from the pipe of a fire-engine. Could we behold these rapid motions incessantly going on within us, it would overpower our minds with astonishment, and even with terror. We should be apt to feel alarmed on making the smallest exertion, lest the parts of this delicate machine should be broken or de-

ranged, and its functions interrupted. The arteries into which the blood is forced, branch in every direction through the body, like the roots and branches of a tree; running through the substance of the bones, and every part of the animal frame, until they are lost in such fine tubes as to be wholly invisible. In the parts where the arteries are lost to the sight, the veins take their rise; and, in the commencement, are also imperceptible.

**RESPIRATION.**—The organs of respiration are the *lungs*. They are divided into five lobes; three of which lie on the right, and two on the left side of the thorax. The substance of the lungs is chiefly composed of infinite ramifications of the trachea, or windpipe, which, after gradually becoming more and more minute, terminate in little cells or vesicles, which have a free communication with one another. At each inspiration, these pipes and cells are filled with air, which is again discharged by expiration. In this manner, a circulation of air, which is necessary to the existence of men and other animals, is constantly kept up as long as life remains. The air-cells of the lungs open into the windpipe, by which they communicate with the external atmosphere. The whole internal structure of the lungs is lined by a transparent membrane, estimated at only the thousandth part of an inch in thickness; but whose surface, from its various convolutions, measures fifteen square feet, which is equal to the external surface of the body. On this thin and extensive membrane innumerable veins and arteries are distributed, some of them finer than hairs; and through these vessels all the blood of the system is successively propelled, by a most curious and admirable mechanism. It has been computed that the lungs, on an average, contain about 280 cubic inches, or about five English quarts of air. At each inspiration, about forty cubic inches of air are received into the lungs, and the same quantity discharged at each expiration. On the supposition that twenty respirations take place in a minute, it will follow that, in one minute, we inhale 300 cubic inches; in an hour, 48,000; and in a day, one million one hundred and fifty-two thousand cubic inches—a quantity which would fill seventy-seven wine hog-heads, and would weigh fifty-three pounds Troy. By means of this function, a vast body of air is daily brought into contact with the mass of blood, and communicates to it its vivifying influence; and, therefore, it is of the utmost importance to health, that the air, of which we breathe so considerable a quantity, should be pure and uncontaminated with noxious effluvia.

In respiration, the air meets the blood in the lungs, and part of the oxygen of the atmosphere is absorbed by it, and imparts to it its red color. Part of the oxygen is also converted into carbonic acid by combining with carbon, or charcoal, in the lungs. In every instance, air which has been respired loses a part of its oxygen; the quantity varies at different times, according to the operation of certain external agents. It is reckoned that, upon an average, a man under ordinary circumstances consumes 45,000 cubic inches, or 15,500 grains of oxygen, in 24 hours. A quantity of carbonic acid is at the same time produced, which is generally somewhat less than the oxygen consumed, and may be reckoned at 40,000 cubic inches in 24 hours. It has been found that in the human species different individuals consume different quantities of oxygen, and of course return different quantities of carbonic acid. The breath expired has been shown to contain from 6 to 8 per

cent. of carbonic acid. It has been found that the nitrogen of the air inspired is sometimes returned in full volume, and sometimes is partially retained and disappears. On the whole, as respiration is one of the most important functions of animal life, on which our very existence depends, so we may plainly perceive, from the above and other circumstances, with what a variety of other functions it is connected, and on what a variety of minute and invisible processes its operations depend.

**DIGESTION.**—This process is performed by the *stomach*, which is a membranous and muscular bag, furnished with two orifices. By the one, it has a communication with a gullet, and by the other, with the bowels. The food, after being moistened by the saliva, is received into the stomach, where it is still further diluted by the *gastric juice*, which has the power of dissolving every kind of animal and vegetable substance. Part of it is afterward absorbed by the *lymphatic* and *lacteal* vessels, and carried into the circulating system, and converted into blood for supplying that nourishment which the perpetual waste of our bodies demands.

**PERSPIRATION** is the evacuation of the juices of the body through the pores of the skin. It has been calculated that there are above *three hundred thousand millions of pores* in the glands of the skin which covers the body of a middle-sized man. Through these pores more than one-half of what we eat and drink passes off by *insensible* perspiration. If we consume eight pounds of food in a day, five pounds of it are insensibly discharged by perspiration. During a night of seven hours' sleep, we perspire about forty ounces, or two pounds and a half. At an average, we may estimate the discharge from the surface of the body, by sensible and insensible perspiration, at from half an ounce to four ounces an hour. This is a most wonderful part of the animal economy, and is absolutely necessary to our health, and even to our very existence. When *partially* obstructed, colds, rheumatisms, fevers, and other inflammatory disorders, are produced; and were it completely obstructed, the vital functions would be clogged and impeded in their movements, and death would inevitably ensue.

**SENSATION.**—The *nerves* are generally considered as the instruments of sensation. They are soft white cords which proceed from the brain and spinal marrow. They come forth originally by pairs. Ten pair proceed from the medullary substance of the brain, which are distributed to all parts of the head and neck. Thirty pair proceed from the spinal marrow, through the vertebræ, to all the other parts of the body; being forty in all. These nerves, the ramifications of which are infinitely various and minute, are distributed upon the heart, lungs, blood-vessels, bowels, and muscles, until they terminate on the skin or external covering of the body. Impressions of external objects are received by the brain from the adjacent organs of sense, and the brain exercises its commands over the muscles and limbs by means of the nerves.

Without prosecuting these imperfect descriptions further, I shall conclude this very hasty sketch with the following summary of the parts of the body, in the words of Bonnet:—"The *bones*, by their joints and solidity, form the foundation of this fine machine; the *ligaments* are strings which unite the parts together; the *muscles* are fleshy substances, which act as elastic springs to put them in motion; the *nerves*, which are dispersed over the whole body, connect all the parts

together; the *arteries* and *veins* like rivulets, convey life and health throughout; the *heart*, placed in the center, is the focus where the blood collects, or the acting power by means of which it circulates and is preserved; the *lungs*, by means of another power draw in the external air, and expel hurtful vapors; the *stomach* and intestines are the magazines where everything that is required for the daily supply is prepared; the *brain*, that seat of the soul, is formed in a manner suitable to the dignity of its inhabitant; the *senses*, which are the soul's ministers, warn it of all that is necessary either for its pleasure or use.\* Adorable Creator! with what wonderful art hast thou formed us! Though the heavens did not exist to proclaim thy glory—though there were no created being upon earth but myself, my own body might suffice to convince me that thou art a God of unlimited power and infinite goodness."

This subject suggests a variety of moral and religious reflections, but the limits to which I am confined will permit me to state only the following:—

1. The economy of the human frame, when seriously contemplated, has a tendency to excite admiration and astonishment, and to *impress us with a sense of our continual dependence on a Superior Power*. What an immense multiplicity of machinery must be in action, to enable us to breathe, to feel, and to walk! Hundreds of bones of diversified forms, connected together by various modes of articulation; hundreds of muscles to produce motion, each of them acting in at least ten different capacities (see p. 36); hundreds of tendons and ligaments to connect the bones and muscles; hundreds of arteries to convey the blood to the remotest part of the system; hundreds of veins to bring it back to its reservoir the heart; thousands of glands secreting humors of various kinds from the blood; thousands of lacteal and lymphatic tubes, absorbing and conveying nutriment to the circulating fluid; millions of pores, through which the perspiration is continually issuing; an infinity of ramifications of nerves, diffusing sensation throughout all the parts of this exquisite machine; and the heart at every pulsation exerting a force of a hundred thousand pounds, in order to preserve all this complicated machinery in constant operation! The whole of this vast system of mechanism must be in action before we can walk across our apartments! We admire the operation of a steam-engine, and the force it exerts. But, though it is constructed of the hardest materials which the mines can supply, in a few months, some of its essential parts are worn and deranged, even although its action should be frequently discontinued. But the animal machine, though constructed, for the most part, of the softest and most flabby substances, can go on without intermission in all its diversified movements, by night and by day, for the space of eighty or a hundred years! the heart giving ninety-six thousand strokes every twenty-four hours, and the whole mass of blood rushing through a thousand pipes of all sizes every four minutes! And is it *man* that governs these nice and complicated movements? Did *he* set the heart in motion, or induce it with the muscular force it exerts? And when it has ceased to beat, can *he* command it again to resume its functions? Man knows neither the secret springs of the machinery within him, nor the half of the purposes for which they serve, or of the movements they perform. Can anything more strikingly

\* Contemplation of Nature, vol. i, p. 64

demonstrate our dependence every moment on a Superior Agent, and that it is "in God we live and move and have our being?" Were a single pin of the machinery within us, and over which we have no control, either broken or deranged, a thousand movements might instantly be interrupted, and our bodies left to crumble into the dust.

It was considerations of this kind that led the celebrated physician Galen, who was a skeptic in his youth, publicly to acknowledge that a Supreme Intelligence must have operated in ordaining the laws by which living beings are constructed. And he wrote his excellent treatise, "On the uses of the parts of the human frame," as a solemn hymn to the Creator of the world. "I first endeavor from His works," he says, "to know myself, and afterward by the same means to show him to others; to inform them how great is his wisdom, his goodness, his power." The late Dr. Hunter has observed, that Astronomy and Anatomy are the studies which present us with the most striking view of the two most wonderful attributes of the Supreme Being. The first of these fills the mind with the idea of his immensity, in the largeness, distances, and number of the heavenly bodies; the last astonishes us with his intelligence and art, in the variety and delicacy of animal mechanism.

2. The study of the animal economy has a powerful tendency to excite emotions of gratitude. Man is naturally a thoughtless and ungrateful creature. These dispositions are partly owing to ignorance of the wonders of the human frame, and of the admirable economy of the visible world; and this ignorance is owing to the want of those specific instructions which ought to be communicated by parents and teachers, in connection with religion. For there is no rational being, who is acquainted with the structure of his animal system, and reflects upon it with the least degree of attention, but must feel a sentiment of admiration and gratitude. The science which unfolds to us the economy of our bodies, shows us, on what an infinity of springs and motions and adaptations, our life and comfort depend. And when we consider, that all these movements are performed without the least care or laborious effort on our part, if we be not altogether brutish, and insensible of our dependence on a Superior Power, we must be filled with emotions of gratitude toward Him whose hands have made and fashioned us, and who giveth us life, and breath, and all things." Some of the motions to which I have adverted depend upon our will; and with what celerity do they obey its commands? Before we can rise from our chair, and walk across our apartment, a hundred muscles must be set in motion; every one of these must be relaxed or constricted, just to a certain degree, and no more; and all must act harmoniously at the same instant of time; and at the command of the soul, all these movements are instantaneously performed. When I wish to lift my hand to my head, every part of the body requisite to produce the effect is put in motion: the nerves are braced, the muscles are stretched or relaxed, the bones play in their sockets, and the whole animal machine concurs in the action, as if every nerve and muscle had heard a sovereign and resistless call. When I wish, the next moment, to extend my hand to my foot, all these muscles are thrown into a different state, and a new set are brought along with them into action; and thus we may vary, every moment, the movements of the muscular system, and the mechanical actions it produces, by a simple change in our volition. Were we not daily accustomed

to such varied and voluntary movements, or could we contemplate them in any other machine, we should be lost in wonder and astonishment.

Beside these voluntary motions, there are a thousand important functions which have no dependence upon our will. Whether we think of it or not, whether we be sleeping or waking, sitting or walking—the heart is incessantly exerting its muscular power at the center of the system, and sending off streams of blood through hundreds of pipes; the lungs are continually expanding and contracting their thousands of vesicles, and imbibing the vital principle of the air; the stomach is grinding the food; the lacteals and lymphatics are extracting nourishment from the blood; the liver and kidneys drawing off their secretions; and the perspiration issuing from millions of pores. These, and many other important functions with which we are unacquainted, and over which we have no control, ought to be regarded as the immediate agency of the Deity within us, and should excite our incessant admiration and praise.

There is one peculiarity in the constitution of our animal system, which we are apt to overlook, and for which we are never sufficiently grateful; and that is, *the power it possesses of self-restoration*. A wound heals up of itself; a broken bone is made firm again by a callus; and a dead part is separated and thrown off. If all the wounds we have ever received were still open and bleeding afresh, to what a miserable condition should we be reduced! But by a system of internal powers, beyond all human comprehension as to the mode of their operation, such dismal effects are effectually prevented. In short, when we consider, that health depends upon such a numerous assemblage of moving organs, and that a single spring out of action might derange the whole machine, and put a stop to all its complicated movements, can we refrain from joining with the Psalmist in his pious exclamation, and grateful resolution, "How precious are thy wonderful contrivances concerning me, O God! how great is the sum of them! I will praise thee; for I am fearfully and wonderfully made. Marvelous are thy works, and that my soul knoweth right well."

Omitting the consideration of several other departments of science, I shall, in the meantime, notice only another subject connected with religion, and that is

#### HISTORY.

History embraces a record and description of past facts and events in reference to all the nations and ages of the world, in so far as they are known, and have been transmitted to our time.—As Natural History contains a record of the operations of the Creator in the material world, so Sacred and Civil History embraces a record of his transactions in the moral and intellectual world, or, in other words, a detail of the plans and operations of his Providence, in relation to the inhabitants of our globe.

During the period of 3500 years from the creation of man, the Sacred History contained in the Old Testament is our only source of information in reference to the state of mankind, and the events which happened to the human race throughout that long interval. From the creation of Adam to the Deluge—a period of about 2000 years, according to the Septuagint chronology—we have no authenticated account of what happened to the inhabitants of the world, but that which is recorded in the first eight chapters of the

book of Genesis. And during a period of 1500 years after the flood, the Sacred History is still our only sure guide as to the events which took place among the nations of the earth. This history, however, relates chiefly to the inhabitants of Judea, and the surrounding nations,—so that the greater portion of the history of man, in reference to all the other nations of the world, remains to be learned in a future state. The Old Testament records carry down our views of the history of man to the period of the Jewish captivity, and to about a hundred years posterior to that event, that is, to within four or five hundred years of the Christian era. About this period *Civil History* becomes definite and authentic, and fills up, in some measure, the chasm which is left in the Sacred History, so that, from this period downward to the present time—with the exception of the New Testament records—we are indebted to civil or profane history, written by men of different nations, for all our knowledge of the transactions of mankind and of the events which have befallen them during the bypast period of 2500 years.

Civil history has been divided into *Ancient* and *Modern* History. Ancient history stretches back as far as the authentic records of nations can carry us; but we have no records to be depended upon, separate from Revelation, which can carry us farther back in the lapse of past ages, than about a thousand years before the Christian era. This department of historic record comprehends the history of the *Egyptians*—the *Assyrians* and *Babylonians*—the *Jews* and *Phœnicians*—the *Medes* and *Persians*—the *Scythians* and *Gills*—the *Carthaginians*,—and particularly the history of the *Greeks* and of the *Romans*, which forms by far the larger portion of ancient history, extending from the building of Rome in the year 753 before Christ, to the subversion of the Roman empire in the 6th century of the Christian era, a period of about 1300 years.—*Modern* history commences where ancient history ends, about the 6th or 7th century, and comprises the history of France, Germany, Britain, Spain, Portugal, Italy, and other countries in Europe, together with what is known in modern times respecting the events which have happened in the Kingdoms of Asia and Africa, and in the settlements of Australasia and America. In reference to all such historical records, it is deeply to be lamented that they contain little else than details of wars, slaughters and devastations, and chiefly present to our view pictures of extortion, assassinations, wholesale robberies, the destruction of empires, the burning of cities, and the desolation of provinces. From these records, however, we may learn such instructions as the following:—

Through the medium of sacred history we learn the period and the manner of man's creation;—the reason of his fall from the primitive state of integrity in which he was created, and the dismal consequences which ensued;—the various movements of providence in order to his recovery, and the means by which human redemption was achieved;—the manner in which the Gospel was at first promulgated, the countries into which it was carried, and the important effects it produced.—Through the medium of civil history we learn the deep and universal depravity of mankind, as exhibited in the wars, dissensions, and ravages which have desolated our fallen race in every period and in every land; we learn the desperate wickedness of the human heart in the more private acts of ferocity, cruelty, and injustice, which in all ages men have perpetrated upon each other;—we be-

hold the righteousness of the supreme Ruler of the world, and the equity of his administration in the judgments which have been inflicted on wicked nations; and the improbability, nay, the *impossibility* of men being ever restored to moral order and happiness, without a more extensive diffusion of the blessings of the gospel of peace, and a more cordial acquiescence in the requirements of the divine law.

Such being some of the benefits to be derived from history, it requires no additional arguments to show that this branch of knowledge should occasionally form a subject of study to every intelligent Christian. But in order to render the study of history subservient to the interests of religion, it is not enough merely to gratify our curiosity and imagination, by following out a succession of memorable events, by tracing the progress of armies and of battles, and listening to the groans of the vanquished and the shouts of conquerors. This would be to study history merely as skeptics, as atheists, or as writers of novels.—When we contemplate the facts which the historian presents to our view, we ought to raise our eyes to Him who is the Governor among the nations, “who doth according to his will in the armies of heaven and among the inhabitants of the earth,” and who overrules the jarring interests of mortals, for promoting the prosperity of that kingdom which shall never be moved. We should view the immoral propensities and dispositions of mankind as portrayed in the page of history, as evidences of the depravity of our species, and as excitements to prepare, with unremitting energy, the knowledge of that Religion, whose sublime doctrines and pure precepts alone can counteract the stream of human corruption, and unite all nations in one harmonious society. We should view the contests of nations, and the results with which they are accompanied, as guided by that invincible hand which “mustereth the armies to the battle;” and should contemplate them either as the accomplishment of Divine predictions, as the inflictions of retributive justice, as paving the way for the introduction of rational liberty and social happiness among men, or as ushering in that glorious period, when “the knowledge of the Lord shall cover the earth,” and the nations shall learn war no more.

Thus I have taken a very cursory survey of some of these sciences which stand in a near relation to the objects of Religion; and which may indeed be considered as forming so many of its subordinate branches. There are many other departments of knowledge, which at first view do not seem to have any relation to Theological science; and yet, on a closer inspection, will be found to be essentially connected with the several subjects of which I have been treating. For example—some may be apt to imagine that Arithmetic, Geometry, Trigonometry, and other branches of Mathematics, can have no relation to the leading objects of Religion. But if these sciences had never been cultivated, the most important discoveries of astronomy, geography, natural philosophy, and chemistry, would never have been made; ships could not have been navigated across the ocean; distant continents, and the numerous “isles of the sea,” would have remained unexplored, and their inhabitants left to grope in the darkness of heathenism; and most of those instruments and engines by which the condition of the human race will be gradually meliorated, and

the influence of Christianity extended, would never have been invented. Such is the dependence of every branch of useful knowledge upon another, that were any one portion of science, which has a practical tendency, to be discarded, it would prevent to a certain degree the improvement of every other. And consequently, if any one science can be shown to have a connection with religion, all the rest must likewise stand in a certain relation to it. It must, therefore, have a pernicious effect on the minds of the mass of the Christian world, when preachers in their sermons endeavor to undervalue scientific knowledge, by attempting to contrast it with the doctrines of Revelation. It would be just as reasonable to attempt to contrast the several doctrines, duties, and facts recorded in the New Testament, with each other, in order to determine their relative importance, and to show which of them might be altogether overlooked and discarded.—The series of facts and of divine revelations comprised in the Bible; the moral and political events which diversify the history of nations; and the physical operations that are going on among the rolling worlds on high, and in the chemical changes of the invisible atoms of matter—are all parts of *one* comprehensive system, under the direction of the Eternal Mind; every portion of which must have a certain relation to the whole. And therefore, instead of attempting to degrade one part of the Divine fabric, in order to enhance another, our duty is to take an expansive view of the whole, and to consider the symmetry and proportion of its parts, and their mutual bearings and relations, in so far as our opportunities and the limited faculties of our minds will permit.

If the remarks which have been thrown out in this chapter, respecting the connection of the Sciences with Religion, have any foundation, it will

follow—that Sermons, Lectures, systems of Divinity, and Religious Periodical works, should embrace occasional illustrations of such subjects, for the purpose of expanding the conceptions of professed Christians, and of enabling them to take large and comprehensive views of the perfections and the providence of the Almighty.—It is much to be regretted, that so many members of the Christian church are absolute strangers to such studies and contemplations; while the time and attention that might have been devoted to such exercises, have in many cases been usurped by the most groveling affections, by foolish pursuits, by gossiping chit-chat, and slanderous conversation. Shall the most trifling and absurd opinions of ancient and modern heretics be judged worthy of attention, and occupy a place in Religious journals, and even in discussions from the pulpit; and shall “the mighty acts of the Lord,” and the visible wonders of his power and wisdom, be thrown completely into the shade! To survey with an eye of intelligence the wide-extended theater of the Divine operations—to mark the agency of the Eternal Mind in every object we behold, and in every movement within us and around us, are some of the noblest attainments of the rational soul; and, in conjunction with every other Christian study and acquirement, are calculated to make “the man of God perfect, and thoroughly furnished unto every good work.” By such studies we are, in some measure, assimilated to the angelic tribes, whose powers of intellect are forever employed in such investigations; and are gradually prepared for bearing a part in their immortal hymn—“Great and marvelous are thy works, Lord God Almighty; just and true are thy ways, thou King of Saints! Thou art worthy to receive glory and honor and power; for thou hast created all things, and ‘or thy pleasure they are and were created.”

## CHAPTER III.

### THE RELATION WHICH THE INVENTIONS OF HUMAN ART BEAR TO THE OBJECTS OF RELIGION.

In this chapter I shall briefly notice a few philosophical and mechanical inventions, which have an obvious bearing on Religion, and on the general propagation of Christianity among the nations.

The first, and perhaps the most important of the inventions to which I allude, is the ART OF PRINTING. This art appears to have been invented (at least in Europe) about the year 1430, by one Laurentius, or Laurence Koster, a native of Haerlem, a town in Holland. As he was walking in a wood near the city, he began to cut some letters upon the rind of a beech tree, which, for the sake of gratifying his fancy, being impressed on paper, he printed one or two lines as a specimen for his grand-children to follow. This having succeeded, he meditated greater things; and, first of all, invented a more glutinous writing-ink, because he found the common ink sunk and spread; and thus formed whole pages of wood with letters cut upon them.\* By the gradual improvement

of this art, and its application to the diffusion of knowledge, a new era was formed in the annals of the human race, and in the progress of science, religion, and morals. To it we are chiefly in-

dividuals beside Laurentius, chiefly by one *Faust*, commonly called Dr. Faustus; by Schoeffer, and by Guttenberg. It appears that the art, with many of its implements, was stolen from Laurentius by one of his servants, whom he had bound by an oath to secrecy, who fled to Mentz, and first commenced the process of printing in that city. Here the art was improved by Faust and Schoeffer, by their invention of *metallic*, instead of *wooden* types, which were first used. When Faust was in Paris, disposing of some Bibles he had printed, at the low price (as was then thought) of sixty crowns, the number, and uniformity of the copies he possessed, created universal agitation and astonishment. Informations were given to the police against him as a magician, his lodgings were searched, and a great number of copies being found, they were seized; the red ink with which they were embellished was said to be his blood; it was seriously adjudged that he was in league with the Devil; and if he had not fled from the city, most probably he would have shared the fate of those whom ignorant and superstitious judges, at that time, condemned for witchcraft. From this circumstance, let us learn to beware how we view the inventions of genius, and how we treat those whose ingenious contrivances may afterward be the means

\* I am aware that the honor of this invention has been claimed by other cities beside Haerlem, particularly by Strasburg, and Mentz, a city of Germany; and by other in-

debted for our deliverance from ignorance and error, and for the most of those scientific discoveries and improvements in the arts which distinguish the period in which we live. Without its aid, the Reformation from Popery could scarcely have been achieved; for had the books of Luther, one of the first reformers, been multiplied by the slow process of hand-writing and copying, they could never have been diffused to any extent; and the influence of bribery and of power might have been sufficient to have arrested their progress, or even to have erased their existence. But, being poured forth from the press in thousands at a time, they spread over the nations of Europe, like an inundation, and with a rapidity which neither the authority of princes, nor the schemes of priests and cardinals, nor the bulls of popes, could counteract or suspend. To this noble invention it is owing that copies of the Bible have been multiplied to the extent of many millions— that ten thousands of them are to be found in every Protestant country—and that the poorest individual who expresses a desire for it, may be furnished with the “Word of Life,” which will guide him to a blessed immortality. That Divine light which is destined to illuminate every region

of enlightening and meliorating mankind.—See Appendix, Note IX.

Various improvements have been made of late years in the art of Printing. The art of *Stereotyping*, which was invented by Mr. Ged, of Edinburgh, in 1725, but was not brought into general use until after the beginning of the present century—is now extensively used, both in Great Britain and America, in the printing of such books as have an extensive circulation. When a page is intended to be *stereotyped*, the types are, in the first instance, put up in the usual way; but instead of being carried to the press, the page is plastered over with liquid stucco to the thickness of about half an inch, so that a level cake is formed on the surface of the types. As soon as the stucco hardens, the cake is separated from the types, and on being turned up, shows a complete mold-like representation of the faces of the types; and there being no longer any use for the types, they are carried off and distributed. After the cake is hardened, by putting it into an oven, it is next laid in a square iron pan, at the bottom of which is a movable plate, upon which the mold is placed, with its face downward. The pan is then immersed in a pot of molten lead, and when the lead has run into the mold side of the cake, and formed a thin plate all over, there is produced the perfect appearance of the faces of the types on which the stucco was plastered. The stereotype plates, thus prepared, are next taken to the printing-office and made ready for the press, by placing them on iron or wooden blocks, so that both plate and block make up the exact height of a page of real types.—In this manner any number of copies of a book may be printed at any time, without again incurring the trouble and expense of re-setting the types, as is necessary to be done in printing new editions. Chambers’ “Edinburgh Journal” is regularly stereotyped in this way. The types being put up on the premises of the publishers, are sent off in pages to a stereotype foundry, where two sets of plates are molded. One set of plates is kept for use in Edinburgh, and the other sent in a box, by the Royal Mail or Steam vessel, to London, where it is immediately subjected to a steam press, and in a few hours made to produce 20,000 or more printed sheets.

Steam-printing—which is now coming in general use—appears to have been first introduced by Mr. König, a German, about 1804. The “Time” newspaper, of November 28, 1814, appears to have been the first ever printed by machinery propelled by steam, and the numbers of that paper have been thrown off by the same process ever since. A machine of this description, with one cylinder, throws off from 900 to 1300 sheets in an hour on one side, requiring two boys, one to lay on the paper, and another to receive it when printed. A machine with two cylinders throws off at the rate of from 1600 to 2200 an hour, requiring two boys to lay on the sheets, and two to take them off—exclusively for newspapers. A machine similar to that used by the “Times,” with 4 printing cylinders, requiring the attendance of 8 boys, throws off about 4000 sheets an hour. By the erection of such steam presses, the three grand requisites, speediness of execution, quantity, and cheapness of labor, are secured to an extent which could scarcely have been anticipated in a preceding age, and which is calculated to supply the exigencies of the times in which we live, when knowledge of every description is rapidly diffusing itself among all ranks of the community.

of the globe, and to sanctify and reform men of all nations, and kindreds, and tongues, is accelerated in its movements, and directed in its course through the nations, by the invention of the Art of Printing; and ere long it will distribute among the inhabitants of every land, the “Law and the Testimony of the Most High,” to guide their steps to the regions of eternal bliss. In short, there is not a more powerful engine in the hand of Providence, for diffusing the knowledge of the nature and the will of the Deity, and for accomplishing the grand objects of Revelation, than the art of multiplying books, and of conveying intelligence through the medium of the press. Were no such art in existence, we cannot conceive how an extensive and universal propagation of the doctrines of Revelation could be effected, unless after the lapse of an indefinite number of ages. But with the assistance of this invention, in its present improved state, the island of Great Britain alone, within less than one hundred years, could furnish a copy of the Scriptures to every inhabitant of the world, and could defray the expense of such an undertaking, with much more ease, and with a smaller sum, than were necessary to finish the political warfare in which we were lately engaged.

These considerations teach us that the ingenious inventions of the human mind are under the direction and control of the Governor of the world—are intimately connected with the accomplishment of the plans of his providence; and have a tendency, either directly or indirectly, to promote, over every region of the earth, the progress and extension of the kingdom of the Redeemer. They also show us from what small beginnings the most magnificent operations of the Divine economy may derive their origin. Who could have imagined that the simple circumstance of a person amusing himself by cutting a few letters on the bark of a tree, and impressing them on paper, was intimately connected with the mental illumination of mankind? and that the art which sprang from this casual process was destined to be the principal mean of illuminating the nations, and of conveying to the ends of the earth the “salvation of our God?” But “He who rules in the armies of heaven, and among the inhabitants of the earth,” and who sees “the end from the beginning,” overrules the most minute movements of all his creatures, in subserviency to his ultimate designs, and shows himself in this respect to be “wonderful in counsel and excellent in working.”

The MARINER’S COMPASS.—Another invention which has an intimate relation to religion, is the *Art of Navigation and the invention of the MARINER’S COMPASS*. Navigation is the art of conducting a ship through the sea from one port to another. This art was partly known and practiced in the early ages of antiquity by the Phenicians, the Carthaginians, the Egyptians, the Romans, and other nations of Europe and Asia. But they had no guide to direct them in their voyages, except the sun in the day-time, and the stars by night. When the sky was overcast with clouds, they were thrown into alarms, and durst not venture to any great distance from the coast, lest they should be carried forward in a course opposite to that which they intended, or be driven against hidden rocks, or unknown shores. The danger and difficulty of the navigation of the ancients on this account may be learned from the deliberations, the great preparations, and the alarms of Homer’s heroes, when they were about to cross the Ægean sea, an extent of not more

than 150 miles; and the expedition of the Argonauts under Jason, across the sea of Marmora and the Euxine, to the island of Colchis, a distance of only four or five hundred miles, was viewed as a most wonderful exploit, at which even the gods themselves were said to be amazed. The same thing appears from the narration we have in the Acts of the Apostles, of Paul's voyage from Cesarea to Rome. "When," says Luke, "neither sun nor stars in many days appeared, and no small tempest lay on us, all hope that we should be saved was then taken away." Being deprived of these guides, they were tossed about in the Mediterranean, not knowing whether they were carried to north, south, east, or west. So that the voyages of antiquity consisted chiefly in creeping along the coast, and seldom venturing beyond sight of land: they could not, therefore, extend their excursions by sea to distant continents and nations; and hence the greater portion of the terraqueous globe and its inhabitants were to them altogether unknown. It was not before the invention of the mariner's compass that distant voyages could be undertaken, that extensive oceans could be traversed, and an intercourse carried on between remote continents and the islands of the ocean.

It is somewhat uncertain at what precise period this noble discovery was made; but it appears pretty evident that the mariner's compass was not commonly used in navigation before the year 1420, or only a few years before the invention of printing.\* The loadstone, in all ages, was known to have the property of attracting iron; but its tendency to point toward the north and south seems to have been unnoticed until the beginning of the twelfth century. About that time, some curious persons seem to have amused themselves by making to swim, in a basin of water, a loadstone suspended on a piece of cork; and to have remarked, that, when left at liberty, one of its extremities pointed to the north. They had also remarked, that, when a piece of iron is rubbed against the loadstone, it acquires also the property of turning toward the north, and of attracting needles and filings of iron. From one experiment to another, they proceeded to lay a needle, touched with the magnet, on two small bits of straw floating on the water, and to observe that the needle invariably turned its point toward the north. The first use they seem to have made of these experiments, was to impose upon simple people by the appearance of *magic*. For example, a hollow swan, or the figure of a mermaid, was made to swim in a basin of water, and to follow a knife with a bit of bread upon its point, which had been previously rubbed on the loadstone. The experimenter convinced them of his power, by commanding, in this way, a needle laid on the surface of the water, to turn its point from the north to the east, or in any other direction. But some geniuses, of more sublime and reflective powers of mind, seizing upon these hints, at last applied these experiments to the wants of naviga-

tion, and constructed an instrument, by the help of which the mariner can now direct his course to distant lands, through the vast and pathless ocean. The following figure gives a general representation of the mariner's compass.

Fig. 27.

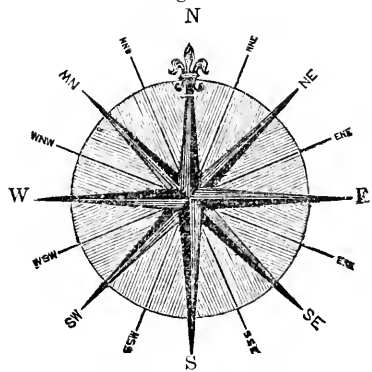

In consequence of the discovery of this instrument, the coasts of almost every land on the surface of the globe have been explored, and a regular intercourse opened up between the remotest regions of the earth. Without the help of this noble invention, America, in all probability, would never have been discovered by the eastern nations, the vast continent of New Holland, the numerous and interesting islands in the Indian and Pacific oceans, the Isles of Japan, and other immense territories inhabited by human beings, would have remained as much unknown and unexplored as if they had never existed. And as the nations of Europe and the western parts of Asia were the sole depositories of the records of Revelation, they could never have conveyed the blessings of salvation to remote countries, and to unknown tribes of mankind, of whose existence they were entirely ignorant. Even although the whole terraqueous globe had been sketched out before them, in all its aspects and bearings, and ramifications of islands, continents, seas, and oceans, and the moral and political state of every tribe of its inhabitants displayed to view, without a guide to direct their course through the billows of the ocean, they could have afforded no light and no relief to cheer the distant nations "who sit in darkness and in the shadow of death." Though the art of printing had been invented; though millions of Bibles were now prepared, adequate to the supply of all the "kindreds of the heathen;" though ships in abundance were equipped for the enterprise, and thousands of missionaries ready to embark, and to devote their lives to the instruction of the Pagan world; all would be of no avail, and the "salvation of God" could never be proclaimed to the ends of the world, unless they had the mariner's compass to guide their course through the trackless ocean.

In this invention, then, we behold a proof of the agency of Divine Providence in directing the efforts of human genius to subserve the most important designs, and contemplate a striking specimen of the "manifold wisdom of God." When the pious and contemplative Israelite reflected on the declaration of the prophets, that "the glory of Jehovah should be revealed, and that all flesh should see it together,"—from the state of the arts which then existed, he must have felt many difficulties in forming a conception of the *manner* in which such predictions should be realized. "The

\* The invention of the compass is usually ascribed to Flavio Gioia, of Amalfi, in Campania, about the year 1302; and the Italians are strenuous in support of this claim. Others affirm that Marcus Paulus, a Venetian, having made a journey to China, brought back the invention with him in 1260. The French also lay claim to the honor of this invention, from the circumstance that all nations distinguish the North point of the card by a *fleur de lis*; and, with equal reason, the English have laid claim to the same honor, from the name *compass*, by which most nations have agreed to distinguish it. But whoever were the inventors, or at whatever period this instrument was first constructed, it does not appear that it was brought into general use before the period mentioned in the text.



great and wide sea," now termed the Mediterranean, formed the boundary of his view, beyond which he was unable to penetrate. Of the continents and "the isles afar off," and of the far more spacious oceans that lay between, he had no knowledge; and how "the ends of the earth" were to be reached, he could form no conception; and, in the midst of his perplexing thoughts, he could find satisfaction only in the firm belief that "with God all things are possible." But now we are enabled not only to contemplate the grand designs of the Divine economy, but the principal means by which they shall all, in due time, be accomplished, in consequence of the progress of science and art, and of their consecration to the rearing and extension of the Christian church.

The two inventions to which I have now adverted, may, perhaps, be considered as among the most striking instances of the connection of human art with the objects of Religion. But there are many other inventions which, at first view, do not appear to bear so near a relation to the progress of Christianity, and yet have an ultimate reference to some of its grand and interesting objects.

The TELESCOPE.—We might be apt to think, on a slight view of the matter, that there can be no immediate relation between the grinding and polishing of an optic glass, and fitting two or more of them in a tube—and the enlargement of our views of the operations of the Eternal Mind. Yet the connection between these two objects, and the dependence of the latter upon the former, can be fairly demonstrated.—The son of a spectacle-maker of Middleburg in Holland, happening to amuse himself in his father's shop, by holding two glasses between his finger and his thumb, and varying their distances, perceived the weathercock of the church spire opposite to him, much larger than ordinary, and apparently much nearer, and turned upside down. This new wonder excited the amazement of the father; he adjusted two glasses on a board, rendering them moveable at pleasure; and thus formed the first rude imitation of a perspective glass, by which distant objects are brought near to view. Galileo, a philosopher of Tuscany, hearing of the invention, set his mind to work, in order to bring it to perfection. He fixed his glasses at the end of long organ-pipes, and constructed a telescope, which he soon directed to different parts of the surrounding heavens. He discovered four moons revolving round the planet Jupiter—spots on the surface of the Sun, and the rotation of that globe around its axis—mountains and valleys in the Moon—and numbers of fixed stars where scarcely one was visible to the naked eye. These discoveries were made about the year 1610, a short time after the first invention of the telescope. Since that period, this instrument has passed through various degrees of improvement, and, by means of it, celestial wonders have been explored in the distant spaces of the universe, which, in former times, were altogether concealed from mortal view. By the help of telescopes, combined with the art of measuring the distances and magnitudes of the heavenly bodies, our views of the Grandeur of the Almighty, of the plenitude of his Power, and of the extent of his universal Empire, are extended far beyond what could have been conceived in former ages. Our prospects of the range of the divine operations are no longer confined within the limits of the world we inhabit; we can now plainly perceive, that the kingdom of God is not only "an everlasting dominion," but that it extends through the unlimited regions of space,

comprehending within its vast circumference thousands of suns, and ten thousands of worlds, all arranged in majestic order, at immense distances from one another, and all supported and governed "by Him who rides on the Heaven of heavens," whose greatness is unsearchable, and whose understanding is infinite.

The telescope has also demonstrated to us the *literal truth* of those scriptural declarations which assert that the stars are "innumerable." Before the invention of this instrument, not more than about a thousand stars could be perceived by the unassisted eye in the clearest night. But this invention has unfolded to view not only thousands, but hundreds of thousands, and millions, of those bright luminaries, which lie dispersed in every direction throughout the boundless dimensions of space. In the *Milky Way*—a whitish zone or circle which surrounds the heavens—more than ten millions of stars might be distinguished by means of the best telescopes. And the higher the magnifying and illuminating powers of the telescope are, the more numerous those celestial orbs appear; leaving us no room to doubt, that countless myriads more lie hid in the distant regions of creation, far beyond the reach of the finest glasses that can be constructed by human skill, and which are known only to Him "who counts the number of the stars, and calls them by their names."

In short, the telescope may be considered as serving the purpose of a vehicle for conveying us to the distant regions of space. We would consider it as a wonderful achievement, could we transport ourselves two hundred thousand miles from the earth, in the direction of the Moon, in order to take a nearer view of that celestial orb. But this instrument enables us to take a much nearer inspection of that planet than if we had actually surmounted the force of gravitation, traversed the voids of space, and left the earth 250,000 miles behind us. For, supposing such a journey to be accomplished, we should still be ten thousand miles distant from that orb. But a telescope which magnifies objects 240 times, can carry our views within one thousand miles of the Moon; and a telescope, such as Sir W. Herschel's 40 feet reflector, which magnifies 6900 times, would enable us to view the mountains and valleys of the Moon, as if we were transported to a point about 40 miles from her surface.\* We can

\* Though the highest magnifying power of Sir W. Herschel's large telescope, which is now dismantled, was estimated at six thousand times, yet, it does not appear that he ever applied this power with success, when viewing the moon and the planets. The deficiency of light, when using so high a power, would render the view of these objects less satisfactory than when viewed with a power of only a thousand times. Still, it is quite certain, that if any portions of the moon's surface were viewed through an instrument of such a power they would appear as large (but not nearly so bright and distinct) as if we were placed about 40 miles distant from that body. The enlargement of the angle of vision, in this case, or the apparent distance at which the moon would be contemplated, is found by dividing the moon's distance—240,000 miles, by 6000, the magnifying power of the telescope, which produces a quotient of 40—the number of miles at which the moon would appear to be placed from the eye of the observer. Sir W. Herschel appears to have used the highest powers of his telescopes only, or chiefly, when viewing some very minute objects in the region of the stars. The powers he generally used, and with which he made most of his discoveries, were, 227, 460, 754, 932, and occasionally 2010, 3168, and 6450, for the purpose of making experiments of their effect on double stars, etc.

Lord Oxmantown, now Earl of Rosse, after a labor of about three years, completed in 1845 the construction of his reflecting telescope, which is of much larger dimensions than the 40 feet telescope of Herschel. The casting of this speculum took place in April, 1842. The metal is 6 feet

view the magnificent system of the planet Saturn, by means of this instrument, as distinctly, as if we had performed a journey eight hundred millions of miles in the direction of that globe; which, at the rate of 50 miles an hour, would require a period of more than eighteen hundred years to accomplish. By the telescope, we can contemplate the region of the fixed stars, their arrangement into systems, and their immense numbers, with the same distinctness and amplitude of view, as if we had actually taken a flight of ten hundred thousand millions of miles into those unexplored and unexplored regions, which could not be accomplished in several millions of years, though our motion were as rapid as a ball projected from a loaded cannon. We would justly consider it as a noble endowment for enabling us to take an extensive survey of the works of God, if we had the faculty of transporting ourselves to such immense distances from the sphere we now occupy; but by means of the telescopic tube, we may take nearly the same ample views of the dominions of the Creator, without stirring a foot from the limits of our terrestrial abode. This instrument may, therefore, be considered as a providential gift bestowed upon mankind, to serve, in the meantime, as a *temporary substitute*, for those powers of rapid flight with which the seraphim are endowed, and for those superior faculties of motion with which man himself may be invested, when he arrives at the summit of moral perfection.\*

The **MICROSCOPE**.—The *Microscope* is another instrument, constructed on similar principles, which has greatly expanded our views of the "manifold wisdom of God." This instrument, which discovers to us small objects invisible to the naked eye, was invented soon after the invention and improvement of the telescope. By means of this optical contrivance, we perceive a variety of wonders in almost every object in the animal, the vegetable, and the mineral kingdoms. We perceive that every particle of matter, however minute, has a determinate form—that the very scales on the skin of a haddock are all beautifully interwoven and variegated, like pieces of network, which no art can imitate—that the points of the prickles of vegetables, though magnified a thousand times, appear as sharp and well polished as to the naked eye—that every particle of the dust on a moth or a butterfly's wing, is a beautiful and regularly organized feather—that every hair of our head is a hollow tube, with bulbs and roots, furnished with a variety of threads and filaments—and that the pores in our skin, through which the sweat and perspiration flow, are so numerous and minute, that a grain of sand would cover a hundred and twenty-five thousand of them. We perceive animated beings in certain

diameter,  $\frac{5}{16}$  inches thick at the edges, and 5 inches at the center, and its weight is about *three tons*. Its composition is copper and tin—125 parts of copper to 57  $\frac{1}{2}$  of tin. The price of the copper alone is reckoned at about £100. By grinding and polishing, its thickness was reduced  $\frac{1}{8}$  or 1-10 inch. It is formed into a telescope of 50 feet focal length. The casting of this immense specimen, with all the operations connected with it, were accomplished without any accident, and with a degree of success beyond expectation. This specimen has a reflecting surface of 4671 square inches, while that of Herschel's 50 feet telescope had only 1811 square inches on its polished surface; so that the quantity of light reflected from this specimen is considerably more than double that of Herschel's largest reflector. This certainly forms one of the most noble and splendid instruments of the kind that have ever been constructed, and it is not improbable that by its assistance, further interesting discoveries may be made in the regions of the stars.

\* See Appendix, Note X.

liquids, so small that fifty thousand of them would not equal the size of a mite; and yet each of these creatures is furnished with a mouth, eyes, stomach, blood-vessels, and other organs for the performance of animal functions. In a stagnant pool, which is covered with a greenish scum during the summer months, every drop of the water is found to be a world teeming with thousands of inhabitants. The moidy substance which usually adheres to damp bodies, exhibits a forest of trees and plants, where the branches, leaves, and fruit, can be plainly distinguished. In a word, by this admirable instrument we behold the same Almighty hand which rounded the spacious globe on which we live, and the huge masses of the planetary orbs, and directs them in their rapid motions through the sky,—employed, at the same moment, in rounding and polishing ten thousand minute transparent globes in the eye of a fly; and boring and arranging veins and arteries, and forming and clasping joints and claws, for the movements of a mite! We thus learn the admirable and astonishing effects of the Wisdom of God, and that the Divine Care and Benevolence are as much displayed in the construction of the smallest insect, as in the elephant or the whale, or in those ponderous globes which roll around us in the sky. These, and thousands of other views which the microscope exhibits, would never have been displayed to the human mind, had they not been opened up by this admirable invention.

In fine, by means of the two instruments to which I have now adverted, we behold Jehovah's empire extending to infinity on either hand. By the telescope we are presented with the most astonishing displays of his *omnipotence*, in the immense number, the rapid motions, and the inconceivable magnitude, of the celestial globes;—and by the microscope, we behold, what is still more inconceivable, a display of his unsearchable wisdom in the Divine mechanism, by which a drop of water is peopled with myriads of inhabitants—a fact, which, were it not subject to ocular demonstration, would far exceed the limits of human conception or belief. We have thus the most striking and sensible evidence, that, from the immeasurable luminaries of heaven, and from the loftiest seraph that stands before the throne of God, down to this lower world, and to the smallest microscopic animalcule that eludes the finest glass—He is everywhere present, and, by his power, intelligence, and agency, animates, supports, and directs the whole. Such views and contemplations naturally lead us to advert to the character of God, as delineated by the sacred writers, that "He is of great power and mighty in strength;" that "His understanding is infinite;" that "His works are wonderful;" that "His operations are unsearchable, and past finding out;" and they must excite the devout mind to join with fervor in the language of adoration and praise—

When the amazing works, O God!

My mental eye surveys,

Transpand with the view I'm lost  
In wonder, love, and praise."

**STEAM NAVIGATION.**—We might have been apt to suppose, that the chemical experiments that were first made to demonstrate the force of *Steam* as a mechanical agent, could have little relation to the objects of Religion, or even to the comfort of human life and society. Yet it has now been applied to the impelling of ships and large boats along rivers and seas, in opposition to both wind and tide, and with a velocity which, at an average, exceeds that of any other mode of conveyance by

water. And we have no reason to believe that this invention has hitherto attained its highest state of perfection; but that it is still susceptible of such improvements, both in point of expedition and of safety, as may render it by far the most comfortable and speedy conveyance between distant lands, for transporting the volume of inspiration, and the heralds of the gospel of peace, to "the ends of the earth." By the help of his compass, the mariner is enabled to steer his course in the midst of the ocean, in the most cloudy days, and in the darkest nights, and to transport his vessel from one end of the world to another. It now only remains, that navigation be rendered safe, uniform, and expeditious, and not dependent on adverse winds or the currents of the ocean; and there is every reason to expect, as the art of propelling vessels by the force of steam proceeds toward perfection, that these desirable objects will be fully attained. Even at present, as the invention now stands, were a vessel fitted to encounter the waves of the Atlantic, constructed of a proper figure and curvature, with a proper disposition of her wheels, and having room where fuel can be stowed in sufficient quantity for the voyage, at the rate of ten miles an hour, she would pass from the shores of Britain to the coast of America, in less than thirteen days;—and, even at eight miles an hour, the voyage could be completed in little more than fifteen days: so that intelligence might pass and re-pass between the eastern and western Continents within the space of a single month—a space of time very little more than was requisite, eighty years ago, for conveying intelligence between Glasgow and London. The greatest distance at which any two places on the globe can lie from each other is about 12,500 miles; and therefore if a direct portion of water intervene between them, this space could be traversed in fifty-four or sixty days.\* And, if the isthmus of

Panama which connects North and South America, and the isthmus of Suez, which separates the Mediterranean from the Red sea, were cut into wide and deep canals (which we have no doubt will be accomplished as soon as civilized nations have access to perform operations in these territories), every country in the world could then be reached from Europe, in nearly a direct line; or, at most, by a gentle curve, instead of the long, and dangerous, and circuitous route which must now be taken, in sailing for the eastern parts of Asia, and the north-western shores of America. By this means, eight or nine thousand miles of sailing would be saved in a voyage from England to Nootka Sound, or the peninsula of California; and more than six thousand miles in passing from London to Bombay in the East Indies; and few places on the east would be farther distant from each other by water than 15,000 miles; which space might be traversed at the rate stated in the preceding note, in a period of about fifty days.\*

But we have reason to believe, that when this invention, combined with other mechanical assistances, shall approximate nearer to perfection, a much more rapid rate of motion will be effected; and the advantages of this, in a religious, as well as in a commercial point of view, may be easily appreciated; especially at the present period, when the Christian world, now aroused from their slumbers, have framed the grand design of sending a Bible to every inhabitant of the globe. When the empire of the Prince of Darkness shall be shaken throughout all its dependencies, and the nations aroused to inquire after light, and liberty, and divine knowledge—intelligence would thus be rapidly communicated over every region, and between the most distant tribes. "Many would run to and fro, and knowledge would be increased." The ambassadors of the Redeemer, with the Oracles of Heaven in their hands, and the words of salvation in their mouths, would quickly be transported to every clime, "having the everlasting gospel to preach to every nation, and kindred, and tongue, and people."

**AIR BALLOONS.**—Similar remarks may be applied to the *invention of air balloons*. We have heard of some pious people who have mourned over such inventions, and lamented the folly of mankind in studying their construction and witnessing their exhibition. Such dispositions generally proceed from a narrow range of thought and a contracted view of the Divine economy and arrangements in the work of redemption. Though the perversity of mankind has often applied useful inventions to foolish and even to vicious purposes, yet this forms no reason why such inventions should be decried; otherwise the art of printing and many other useful arts might be regarded as inimical to the human race. We have reason to believe that air balloons may yet be brought to such perfection as to be applied to purposes highly beneficial to the progress of the human mind, and subservient, in some degree, for effecting the purposes of Providence in the enlightening and reno-

\* The above statements were written in 1823, when the first edition of this work was published, and were then considered as somewhat extravagant anticipations, which were scarcely expected to be realized, at least in the present age. It is but within the last few years that one of our most distinguished philosophers and engineers, Dr. Lardner, denounced the scheme of attempting to cross the Atlantic by means of steam as an enterprise altogether impracticable. But the navigation of the Atlantic, by means of steam vessels, for several years past, has been regular, and almost as common as with ordinary sailing vessels;—and the rate of motion has been even greater than what we anticipated. The *Great Western* was among the first steam vessels that crossed the Atlantic from Britain to America, in 1838, and accomplished the voyage, in safety, in about 13 days, having on board above a hundred passengers. Since that period other vessels, as the *Acadia*, *Britannia*, *Caledonia*, *Columbia*, etc., have regularly performed voyages to and from the shores of America and Great Britain, and, except in the case of the *President*, they have all been accomplished without any serious accidents,—so that, the practicability and the utility of steam navigation across the ocean may now be considered as fully established. Voyages by steam are likewise now regularly performed to Lisbon, Cadiz, and along the Mediterranean, as far as Alexandria, and from Bombay to Suez along the Arabian and the Red sea;—and therefore we have reason to expect that, in the course of a very few years every sea and ocean on the surface of the globe will be traversed by steam vessels, promoting a rapid intercourse between all the nations, tribes, and families of the earth.—The rate of motion at which such vessels are impelled across the Atlantic may be deduced from the following facts. The first voyage of the *Britannia*, which sailed on the 14th July, 1840, from Liverpool to Halifax, was accomplished in 12 days, 10 hours; and her return homeward occupied only 10 days. The outward voyage of the *Columbia*, which sailed from Liverpool, May 19, 1842, was performed in 11 days, 22 hours; and her voyage home from Halifax in 9 days, 17 hours. Her voyage from Boston, in the United States, including a stoppage of 6 hours at Halifax to land and take in passengers and mails, was performed in 11 days, 6 hours, from that city to Liverpool. Of 28 voyages of the *Acadia*, *Britannia*, *Caledonia*, and *Columbia*, performed in the years 1840, 1841, and 1842, between Liverpool

and Halifax—the average time employed in the passage is found to be as follows: *Outward voyage* to Halifax 12 days, 6 hours;—*Homeward* to Liverpool 11 days, 6 hours. It thus appears that intelligence may now pass and re-pass between Britain and the continent of America in 22 or 24 days, or little more than 3 weeks, so that it is possible a person might receive an answer to a communication sent to America in less than 3½ weeks. At this rate, 15,000 miles—or the greatest distance between any two places on the globe by water, might be traversed in about 50 days.

\* See Appendix, Note XI.

ration of mankind. For this purpose, it is only requisite that some contrivance, or chemical or mechanical principles, be suggested, analogous to the sails or rudder of a ship, by which they may be moved in any direction, without being directed solely by the course of the wind; and there can be little doubt that such a contrivance is possible to be effected. It requires only suitable encouragement to be given to ingenious experimental philosophers, and a sufficient sum of money to enable them to prosecute their experiments on an extensive scale. To the want of such prerequisites it is chiefly owing that the hints on this subject, hitherto suggested, have either failed of success or have never been carried into execution. A more simple and expeditious process for filling balloons has lately been effected,—the use of the *parachute*, by which a person may detach himself from the balloon, and descend to the earth, has been successfully tried,—the lightning of heaven has been drawn from the clouds, and forced to act as a mechanical power in splitting immense stones to pieces,—the atmosphere has been analyzed into its component parts, and the wonderful properties of the ingredients of which it is composed exhibited in their separate state;—and why then should we consider it as at all improbable that the means of producing a horizontal direction in aerial navigation may soon be discovered? Were this object once effected, balloons might be applied to the purposes of surveying and exploring countries hitherto inaccessible, and of conveying the messengers of divine mercy to tribes of our fellow-men, whose existence is as yet unknown.

We are certain that every portion of the inhabited world must be thoroughly explored, and its inhabitants visited, before the salvation of God can be carried fully into effect; and for the purpose of such explorations, we must of course resort to the inventions of human genius in art and science. Numerous tribes of the sons of Adam are, doubtless, residing in regions of the earth with which we have no acquaintance, and to which we have no access by any of the modes of conveyance presently in use. More than one half of the interior parts of Africa and Asia, and even of America, are wholly unknown to the inhabitants of the civilized world. The vast regions of Chinese Tartary, Thibet, Siberia, and the adjacent districts; the greater portion of Africa, and the continent of New Holland; the extensive isles of Borneo, Sumatra, New Guinea, and Japan, the territory of the Amazons, and the internal parts of North America, remain, for the most part, unknown and unexplored. The lofty and impassable ranges of mountains, and the deep and rapid rivers, which intervene between us and many of those regions, together with the savage and plundering hordes of men and the tribes of ravenous beasts through which the traveler must push his way—present to European adventurers barriers which they cannot expect to surmount, by the ordinary modes of conveyance, for a lapse of ages. But, by balloons constructed with an apparatus for directing their motions, all such obstructions would at once be surmounted. The most impenetrable regions, now hemmed in by streams and marshes and lofty mountains, and a barbarous population, would be quickly laid open; and cities and nations, lakes and rivers, and fertile plains, to which we are now entire strangers, would soon burst upon the view. And the very circumstance that the messengers of peace and salvation descended upon such unknown tribes from the region of the clouds, might arouse their minds and excite their attention and regard to the message of divine mercy which they

came thither to proclaim.\* Such a scene (and it may probably be realized) would present a literal fulfillment of the prediction of “*angels flying through the midst of*” the aerial “*heaven*, having the everlasting gospel to preach to them that dwell upon the earth, and to every kindred and nation.”

That the attention of the philosophical world is presently directed to this subject, and that we have some prospect of the views above suggested being soon realized, will appear from the following notice, which some time ago made its appearance in the London scientific journals:—A prize being offered for the discovery of a horizontal direction in aerostation, M. Mingreli of Bologna, M. Pietropoli of Venice, and M. Lember of Nurnberg, have each assumed the merit of resolving this problem. It does not appear that any one of these has come forward to establish, by practical experiment, the validity of his claim; but a pamphlet has lately been reprinted in Paris (first printed at Vienna) on this subject, addressed to all the learned societies in Europe. The following passage appears in the work: “Professor Robertson proposes to construct an aerostatic machine, 150 feet in diameter, to be capable of raising 72,954 kilograms, equivalent to 149,037 lbs. weight (French). To be capable of conveying all necessaries for the support of sixty individuals, scientific characters, to be selected by the academicians, and the aerial navigations to last for some months, exploring different heights and climates, etc., in all seasons. If, from accident or wear, the machine, elevated above the ocean, should fail in its functions, to be furnished with a ship that will insure the return of the aeronauts.”

Of late years, the attention of several scientific gentlemen has been directed to the improvement of aerial navigation, and it is the opinion of many that the problem of giving to balloons a horizontal direction has been in some measure solved. About the year 1837 some plans of this description were laid before a committee of the Royal Society, and an association was attempted to be formed for exploring the continent of Africa by means of a large balloon which was to be constructed for this special purpose; but after the projectors had proceeded a certain length, the scheme was allowed to drop, for want of patronage and support. In

\* In this point of view, we cannot but feel the most poignant regret at the conduct of the Spaniards, after the discovery of America, toward the natives of that country. When those untutored people beheld the ships which had conveyed Columbus and his associates from the eastern world, the dresses and martial order of his troops, and heard their music, and the thunder of their cannon, they were filled with astonishment and wonder at the strange objects presented to their view; they fell prostrate at their feet, and viewed them as a superior race of men. When Cortez afterward entered the territories of Mexico, the same sentiments of reverence and admiration seemed to pervade its inhabitants. Had pure Christian motives actuated the minds of these adventurers, and had it been their ruling desire to communicate to those ignorant tribes the blessings of the Gospel of peace, and to minister to their external comfort, the circumstance now stated would have been highly favorable to the success of missionary exertion, and would have led them to listen with attention to the message from Heaven. But, unfortunately for the cause of religion, treachery, lust, cruelty, selfishness, and the cursed love of gold, predominated over every other feeling, affixed a stigma to the Christian name, and rendered their curses instead of blessings, to that newly discovered race of men. It is most earnestly to be wished, that, in future expeditions in quest of unknown tribes, a few intelligent and philanthropic missionaries were appointed to direct the adventurers in their moral conduct and intercourse with the people they visit, in order that nothing inconsistent with Christian principle make its appearance. The uniform manifestation of Christian benevolence, purity, and rectitude, by a superior race of men, would win the affections of a rude people far more effectually than all the pomp and ensigns of military parade.

the year 1840, Mr. Green, the most celebrated aeronaut of modern times, who has performed several hundreds of aerial voyages, proposed making a voyage in a balloon from the American to the European continent, across the Atlantic. In order to convince the scientific public of the practicability of his propelling or directing a balloon, causing it to ascend or descend, without discharging either gas or ballast—and in a tranquil atmosphere, to move horizontally and *in any direction*—he commenced a series of important experiments, at the *Polytechnic Institution*, London, which excited considerable attention, and created a great sensation among the curious in scientific matters. The machinery made use of by Mr. G. consisted of two *propellers* attached to a spindle, a *rudder*, a *guide-line*, and several *appendages*. The propeller appears to have been somewhat like two sails of a windmill which were whirled round with a rotatory motion, and which were intended to produce an effect both on the horizontal progress of the balloon and likewise in elevating and depressing it.\* The practicability of Mr. Green's plans appears to have been admitted by many scientific gentlemen; and although he has never yet attempted his daring aerial excursion across the Atlantic, yet it is well known that he performed, along with Mr. Mason, in the great Nassau balloon, an aerial voyage from England across the German sea to Weiburg in Germany, one of the most daring and extensive voyages hitherto attempted, and which was accomplished without the least danger. The possibility of an aerial excursion across the Atlantic may perhaps be admitted; but its expediency, in the meantime, may justly be called in question.

As the invention now stands, the balloon, under the direction of such an experienced aeronaut as Mr. Green, might be rendered subservient to many important purposes, particularly in taking a general survey of unknown countries. Suppose a balloon, properly equipped for the purpose, were to be elevated either on the eastern or the western shores of Africa, so as to pass nearly over the central parts of that continent,—by taking advantage of the monsoons, or trade-winds, which blow for a certain period in the same direction—the general aspect and character of this country, with which we are at present so little acquainted, might be laid open to view, at least as to its more prominent and general features. The extent of its lakes—the direction and magnitude of its rivers—the ranges of mountains with which it is diversified—its deserts, forests, and cultivated fields—the positions and magnitude of its cities—the characteristics of its inhabitants, and the probable amount of population—with several other particulars—might all be deduced by an intelligent aeronaut, when passing across such a country at a proper elevation, beside having an opportunity of performing a variety of electric, magnetic, and other scientific experiments, for enlarging our knowledge of the principles and processes of nature. In the same manner the Chinese Empire—of which we know so little—might be extensively surveyed, and our knowledge of that interesting and populous region of the globe rendered more definite and expansive. In both these cases, and several others, the course of the periodical winds might be rendered subservient to the success of the enterprise.

Should any one be disposed to insinuate, that the views now stated on this subject are chimerical and fallacious, I beg leave to remind them, that not more than twenty years ago, the idea of a large vessel, without oars or sails, to be navigated against the wind with the rapidity of twelve miles an hour, would have been considered as next to an impossibility, and a mere fanciful scheme, which could never be realized. Yet we now behold such vehicles transporting whole villages to the places of their destination, with a degree of ease, comfort, and expedition, formerly unknown, and even crossing in safety the wide Atlantic ocean. And little more than fifty years have elapsed, since it would have been viewed as still more chimerical to have broached the idea, that a machine might be constructed, by which human beings might ascend more than two miles above the surface of the earth, and fly through the region of the clouds at the rate of seventy miles an hour, carrying along with them books, instruments, and provisions. Yet both these schemes have been fully realized, and, like many other inventions of the human intellect, are doubtless intended to subserve some important ends in the economy of Divine Providence.\*

\* Balloons were first constructed in the year 1783, by Messrs. S. & J. Montgolfier, paper manufacturers at Annonay, in France. A sheep, a cock, and a duck, were the first animals ever carried up into the air by these vehicles. At the end of their journey, they were found perfectly safe and unhurt, and the sheep was even feeding at perfect ease. The first human being who ascended into the atmosphere in one of those machines, was M. Pilatre de Rozier. This adventurer ascended from amidst an astonished multitude assembled in a garden in Paris, on the 15th October, 1783, in a balloon, whose diameter was 48 feet, and its light about 74; and remained suspended above the city about four hours. M. Lunardi, an Italian, soon after astonished the people of Scotland and England, by his aerial excursions. Dr. G. Gregory gives the following account of his first ascent:—"I was myself a spectator of the flight of Lunardi, and I never was present at a sight so interesting and sublime. The beauty of the gradual ascent, united with a sentiment of terror on account of the danger of the man, and the novelty and grandeur of the whole appearance, are more than words can express. A delicate woman was so overcome with the spectacle, that she died upon the spot as the balloon ascended; several fainted; and the silent admiration of the anxious multitude was beyond anything I had ever beheld."

Balloons have generally been made of varnished silk, and of the shape of a globe or a spheroid (see fig. 28), from thirty to fifty feet in diameter. They are filled with hydrogen gas, which, as formerly stated, is from twelve to fifteen times lighter than common air; and they rise in the atmosphere on the same principle as a piece of cork ascends from

Fig. 28.

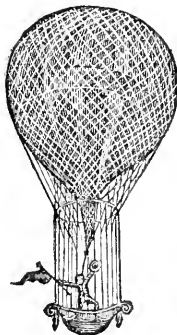

the bottom of a pail of water. The aerial travelers are seated in a basket below the balloon, which is attached to it by means of cords.—The *Parachute* (see fig. 29) is an invention, by which the voyager, in cases of alarm, may be enabled to desert his balloon in mid-air, and descend with

\* The reader will find an account of Mr. Green's experiments in the *Polytechnic Journal* for January and February, 1840, and likewise in the No. of the *Mirror* for April, etc., 1840, vol. 35, with an Engraving of the proposed balloon.

**ACOUSTIC TUNNELS.**—By means of the inventions just now adverted to, when brought to perfection, mankind may be enabled to transport themselves to every region of the globe, with a much greater degree of rapidity than has hitherto been attained. By the help of the microscope, we are enabled to contemplate the invisible worlds of life, and by the telescope we can penetrate into regions far beyond the range of the unassisted eye. By the arts of Writing and Printing we can communicate our sentiments, after a certain lapse of time, to every quarter of the world. In the progress of human knowledge and improvement, it would obviously be of considerable importance, *could we extend the range of the human voice*, and communicate intelligence to the distance of a thousand miles, in the course of two or three hours; or could we hold an occasional conversation with a friend at the distance of twenty or thirty miles. From experiments which have lately been made, in reference to the conveyance of sound, we have some reason to believe that such objects may not be altogether unattainable. It has been long known that wood is a good conductor of sound. If a watch be laid on the one

out injury to the ground. They resemble an umbrella, but are of far greater extent. With one of these contrivances, twenty-three feet in diameter, M. Garnerin, having detached himself from his balloon, descended from a height of more than 4000 feet, and landed without shock or accident.

The above representation (fig. 29) exhibits a view of Mr. Green's balloon, when he ascended from St. James's Park, London, on the occasion of the coronation of George IV. The form of the balloon was nearly of the shape of a pear; it was composed of stripes of variegated silk; and over this was thrown an envelope of net-work, which, passing down, served as a support to the car in which the aeronaut was placed. It may give the reader who has never seen a balloon, a general idea of its form and of the mode in which aerial navigation is performed.

Fig. 29.

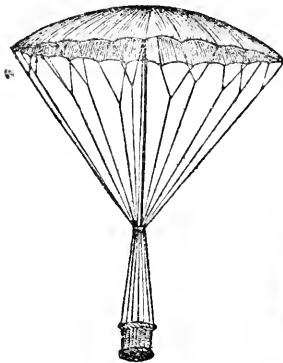

Fig. 30.



Figs. 29 and 30 represent the parachute of M. Garnerin, and the apparatus connected with it. In fig. 20 is shown a cylindrical box, about 3 feet in height and 2 in diameter, which was attached by a straight pole, to a truck or disc at the top, and from this was suspended a large sheet of linen somewhat similar to an umbrella. M. Garnerin stood in the box, and the form the machine assumed on his descent is shown in fig. 29. When first cut from the balloon, it descended with great velocity, and those who witnessed its progress considered his destruction inevitable; but after a few seconds, the canvas opened and the resistance was so great, that the apparatus diminished in its speed, until, on its arrival near the earth, it was not greater than would have resulted from leaping a height of two feet.

end of a long beam of timber, its beating will be distinctly heard, on applying the ear to the other end, though it could not be heard at the same distance through the air. In "Nicholson's Philosophical Journal" for February 1803, Mr. E. Walker describes a simple apparatus, connected with a speaking trumpet, by means of which, at the distance of 17½ feet, he held a conversation with another in whispers, too low to be heard through the air at that distance. When the ear was placed in a certain position, the words were heard as if they had been spoken by an invisible being within the trumpet. And what rendered the deception still more pleasing, the words were more distinct, softer, and more musical, than if they had been spoken through the air.

About the year 1750, a merchant of Cleves, named Jorissen, who had become almost totally deaf, sitting one day near a harpsichord while some one was playing, and having a tobacco-pipe in his mouth, the bowl of which rested accidentally against the body of the instrument, he was agreeably and unexpectedly surprised to hear all the notes in the most distinct manner. By a little reflection and practice, he again obtained the use of this valuable sense: for he soon learned, — by means of a piece of hard wood, one end of which he placed against his teeth, while another person placed the other end on his teeth, — to keep up a conversation, and to be able to understand a whisper. In this way, two persons who have stopped their ears may converse with each other, when they hold a long stick, or a series of sticks, between their teeth, or rest their teeth against them. The effect is the same, if the person who speaks rest the stick against his throat or his breast, or when one rests the stick which he holds in his teeth against some vessel into which the other speaks; and the effect will be the greater, the more the vessel is capable of tremulous motion. These experiments demonstrate the facility with which the softest whispers may be transmitted. Water, too, is found to be a good conductor of sound. Dr. Franklin assures us, that he has heard under water, at the distance of half a mile, the sound of two stones struck against each other. It has also been observed, that the *velocity* of sound is much greater in solid bodies, than in the air. By a series of experiments, instituted for the purpose of determining this point, Mr. Chladni found that the velocity of sound, in certain solid bodies, is 16 or 17 times as great as in air.

But what has a more particular bearing on the object hinted at above, is the experiments, lately made by M. Biot, "on the transmission of sound through solid bodies, and through air, in very long tubes." These experiments were made by means of long cylindrical pipes, which were constructed for conduits and aqueducts, to embellish the city of Paris. With regard to the *velocity* of sound, it was ascertained that "its transmission through cast iron is 10½ times as quick as through air. The pipes by which he wished to ascertain at what distance sounds are audible were 1039 yards, or nearly five furlongs in length. M. Biot was stationed at the one end of this series of pipes, and Mr. Martin, a gentleman who assisted in the experiments, at the other. They heard the lowest voice, so as perfectly to distinguish the words, and to keep up a conversation on all the subjects of the experiments. "I wished," says M. Biot, "to determine the point at which the human voice ceases to be audible, but could not accomplish it: words spoken as low as when we whisper a secret in another's ear were heard and understood; so that not to be heard, there was but one resource,

that of not speaking at all.—This mode of conversing with an invisible neighbor is so singular, that we cannot help being surprised, even though acquainted with the cause. Between a question and answer, the interval was not greater than was necessary for the transmission of sound. For Mr. Martin and I, at the distance of 1639 yards, this time was about  $5\frac{1}{2}$  seconds." Reports of a pistol fired at one end occasioned a considerable explosion at the other. The air was driven out of the pipe with sufficient force to give the hand a smart blow, to drive light substances out of it to the distance of half a yard, and to extinguish a candle, though it was 1639 yards distant from the place where the pistol was fired. A detailed account of these experiments may be seen in *Nicholson's Phil. Jour.* for October, 1811.—Don Gautier, the inventor of the Telegraph, suggested also the method of conveying articulate sounds to a great distance. He proposed to build horizontal tunnels, widening at the remoter extremity, and found that, at the distance of 400 fathoms, or nearly half a mile, the ticking of a watch could be heard far better than close to the ear. He calculated, that a series of such tunnels would convey a message 900 miles in an hour.

From the experiments now stated, it appears highly probable that sounds may be conveyed to an indefinite distance. If one man can converse with another at the distance of nearly three quarters of a mile, by means of the *softest whisper*, there is every reason to believe that they could hold a conversation at the distance of 30 or 40 miles, provided the requisite tunnels were constructed for this purpose. The latter case does not appear more wonderful than the former. Were this point fully determined by experiments conducted on a more extensive scale, a variety of interesting effects would follow, from a practical application of the results. A person, at one end of a large city, at an appointed hour, might communicate a message, or hold a conversation with his friend, at another; friends in neighboring, or even in distant towns, might hold an occasional correspondence by articulate sounds, and recognize each other's identity by their tones of voice. In the case of sickness, accident, or death, intelligence could thus be instantly communicated, and the tender sympathy of friends immediately exchanged. A clergyman sitting in his own room, in Edinburgh, were it at any time expedient, might address a congregation in Musselburgh or Dalkeith, or even in Glasgow. He might preach the same sermon to his own church, and the next hour to an assembly at forty miles distant. And surely there could be no valid objection to trying the effect of an *invisible preacher* on a Christian audience. On similar principles, an apparatus might be constructed for augmenting the strength of the human voice, so as to make it extend its force to an assembled multitude, composed of fifty or a hundred thousand individuals; and the utility of such a power, when the mass of mankind are once thoroughly aroused to attend to rational and religious instruction, may be easily conceived. In short, intelligence respecting every important discovery, occurrence, and event, might thus be communicated, through the extent of a whole kingdom, within the space of an hour after it had taken place.

Let none imagine that such a project is either chimerical or impossible. M. Biot's experiment is decisive, so far as it goes; that the *softest whisper*, without any diminution of its intensity, may be communicated to the distance of nearly three quarters of a mile; and there is nothing but actual

experiment wanting to convince us, that the ordinary tones of the human voice may be conveyed to at least twenty times that distance. We are just now acting on a similar principle in distributing illumination through large cities. Not above 40 or 50 years ago, the idea of lighting our apartments by an invisible substance, produced at ten miles distance, would have been considered as chimerical, and as impossible to be realized, as the idea of two persons conversing together, by articulate sounds, at such a distance. It appears no more wonderful, that we should be able to *hear* at a distance of five or six miles, than that we should be enabled to *see* objects at that distance by the telescope, as distinctly as if we were within a few yards of them. Both are the effects of those principles and laws which the Creator has interwoven with the system of the material world; and when man has discovered the mode of their operation, it remains with himself to apply them to his necessities. What the telescope is to the eye, acoustic tunnels would be to the ear; and thus those senses on which our improvement in knowledge and enjoyment chiefly depends, would be gradually carried to the utmost perfection of which our station on earth will permit. And as to the *expense* of constructing such communications of sound, the *tenth part* of the millions of money expended in the twenty-one years' war in which we were lately engaged, would, in all probability, be more than sufficient for distributing them, in numerous ramifications, through the whole island of Great Britain. Even although such a project were partially to fail of success, it would be a far more honorable and useful national undertaking, than that which now occupies the attention of the despots on the continent of Europe, and might be accomplished with far less expenditure, either of blood or of money. Less than the fourth part of a million of pounds would be sufficient for trying an experiment of this kind, on an extensive scale; and such a sum is considered as a mere *item*, when fleets and armies are to be equipped for carrying destruction through sea and land. When will the war-madness cease its rage! When will men desist from the work of destruction, and employ their energies and their treasures in the cause of human improvement? The most chimerical projects that were ever suggested by the most enthusiastic visionary, are not half so ridiculous and *degrading* to the character of man, as those ambitious and despotic schemes, in which the powers of the earth in all ages have been chiefly engaged.—But on this topic it is needless to enlarge, until more extended experiments shall have been undertaken.

**ELECTRIC TELEGRAPHS.**—The electric and galvanic powers have been lately employed in transmitting telegraphic signals through wires to any assignable distance. More than 12 years ago, Sir H. Davy, Dr. Ritchie, and several others, formed the idea of constructing an electrical telegraph; and in 1837, the model of an apparatus for this purpose was exhibited by Mr. Alexander to the Society of Arts, in Edinburgh. Professor Wheatstone, of King's College, London, lately made considerable improvements in the construction of these instruments, particularly in the reduction of the number of wires requisite in such an apparatus.—The general principle on which such an operation is founded, is, that of causing the galvanic current to deflect a needle poised on a center; and, by certain arrangements, the needle is made to point to any letter on a dial plate. Professor Wheatstone's apparatus consists of two small galvanic troughs or batteries; four lengths

of copper wire; an object resembling a brass clock, with a small opening or dial on the surface sufficient to show a single letter at a time; close by this an upright pivot of brass about 3 inches high, having a circular top inscribed with the letters of the alphabet all round, and from each letter a spike pointing outward. The whole stands on a table, except the wires, which, being four miles in length, and warped in numberless convolutions through the vaults of the college, are observable only at their extremities, in connection with the apparatus. The galvanic property generated in the batteries is made to proceed along the wires, and in its passage to affect the mechanism in the apparatus now described. The letters can be exposed at the rate of two in every second. A gentleman who witnessed its performance, says, "A lady turning the capstan with her finger, brought into view the word L O N D O N, in the time it could be uttered letter by letter, although the idea had to travel through 4 miles of wire."

The capabilities of the principle of this instrument have been tested on the line of the Great Western Railway. In September, 1853, the wires of the electric telegraph were carried to Drayton, a distance of 15 miles from London, and the experiment was attended with complete success. To such a question as the following,—“How many passengers started from Drayton by the 10 o'clock train?” the answer could be transmitted from the terminus to Drayton and back in less than two minutes. The wires of communication pass through a hollow iron tube about an inch and a half in diameter, which is fixed about 6 inches above the ground, parallel with the railway, and about two or three feet distant from it; and it is probable that, by this time, they have been carried forward the whole length of the railway, which extends to Bristol, a distance of 117 miles.

In transmitting the electric influence through wires—however great the distance—the time occupied in the transmission is nearly the same, for there is reason to believe that it flies with the same velocity as *light*, whose rate of motion is nearly two hundred thousand miles in a second. Were wires extended from Britain to China, on the one hand, and to America, on the other, intelligence could be transmitted to those regions in as short a time as in conveying it across a garden or a large hall. It is hard to say to what extent signals may, in point of fact, be communicated in this way, in the course of the improvements which are now going forward. Were the nations of Europe living in perfect amity and peace, and in a friendly communication with each other, telegraphs of this description might be ramified throughout the whole extent of the continent, from north to south, and from east to west; and the expense of constructing them would be but a slight *item*, compared with the sums expended in useless parade, in warfare, and in schemes of folly. They might, at any rate, be spread in different directions throughout the island of Great Britain, or, at least along the great thoroughfares leading toward the metropolis; and offices established at different stages for communicating and receiving intelligence—with prices affixed corresponding to the distance from which the intelligence is conveyed. It is easy to see that such a rapid communication of intelligence—in numerous instances, which our limits will not permit us to specify—might be highly beneficial to the interests of general society.

Thus it appears that the same physical principle or agent which produces the forked and fire-ball lightnings, and all the dread phenomena of a

violent thunder-storm—which rends in pieces the sturdy oak, and strikes whole herds of cattle lifeless to the ground—which displays its terrific energy in the awful phenomena of volcanoes, hurricanes, and earthquakes—that the same agent is now, by human art, rendered subservient to the conveyance of swift intelligence from one place to another, and to many other useful purposes in society—and, perhaps, ere long, its destructive energies may be completely counteracted by the continuance of human ingenuity, when its nature and properties, and its mode of operation, shall be more completely unfolded. And, it is not unlikely, as the investigations of philosophy proceed, that new principles may be discovered in the system of nature, more wonderful than any that have yet come within the reach of our knowledge, which may both enlarge our views of the operations of the Creator, and be applicable to manifold beneficial purposes in the economy of human society.

**RAILWAYS.**—The mode of traveling by means of railways, which has been lately introduced into Great Britain and many other countries, is an improvement no less wonderful and beneficial to society than that of steam navigation, and promises to promote the general intercourse of mankind, and the conveyance of political and commercial intelligence to an extent and with a velocity which former ages could never have anticipated.

It appears that, so early as the year 1676, coals were carried from the mines near Newcastle-upon-Tyne to the banks of the river, by laying rails of timber exactly straight and parallel, on which large carts, with four rollers fitting the rails, and drawn by horses, could convey at once four or five cauldrons of coals. About a century afterward, an *iron* railroad was constructed at the Sheffield colliery. But the first railway resembling those now in use, as a public thoroughfare for the conveyance of goods and passengers, was the “Stockton and Darlington Railway,” which was completed only in 1825, and was the first which was attended with complete success. Several years, however, elapsed before steam locomotive engines were adopted. This noble triumph of art, in the swift conveyance of goods and passengers, was first practically exhibited at the opening of the “Liverpool and Manchester Railway,” on the 15th September, 1830, when it was found that trains of carriages could be conveyed at the rate of 25 or 30 miles an hour. Since this period, railways have been distributed throughout almost all the populous districts of our country.

The rails on which the wheels of the engines and carriages move are all made of iron. At first it was supposed that malleable iron rails were to be preferred; but it is now understood that *cast-iron* rails, if properly made, will endure all the tear and wear to which they are in general subjected. Each individual rail is about 12 feet in length, and 6 inches in depth at the two ends. Their thickness is about one inch, and the upper surface on which the wheel is to run, about two inches, so as to project laterally like the cross top of the letter T. They are pinned together at their extremities, and are supported at intervals of every three feet. The supporters on some lines of railroad consist of *stone* sleepers sunk into the ground; but it is generally admitted that *transverse bars of wood* sunk in the ground are preferable, as both lines of rail are thus kept from separating or shifting, and as stone sleepers present too unyielding a base to the rolling of the wheels. In order to keep the wheels on the rails, they are furnished with thin edges, which dip or



the outside. The wheels of the locomotive have a diameter of about 4 feet; the diameter for the wagon or carriage-wheels is generally from 30 to 36 inches. The locomotive is now generally placed upon six wheels; the front and hind pair being smaller than those in the middle; these middle ones being the wheels upon which, by the action of cranks from the engine, the whole mass is propelled. A chimney rises in front, and a standing place behind is allotted for the engineer, who conducts and regulates the machine. The barrel-like object next the engineer consists of a furnace or fire-box, and the heat generated in it by the consumption of coke, is conducted thence through a great number of tubes in the cylinder, and finally escapes at the chimney. By means of lever handles affecting the mechanism, the engineer can at pleasure produce or stop the motion as effectually as a coach-driver could set off, or arrest the progress of his horses. Immediately behind the locomotive is a carriage called the *tender*, which is loaded with fuel, and has a tank round its sides containing water. The weight of a locomotive, supplied with its proper quantity of water and fuel, is about 12 tons. When filled

with water and fuel, the tender weighs about 7 tons; it can carry 700 gallons of water, and eight hundred weight of coke—which will form a supply for a trip of 30 or 40 miles.

The *expenses* incurred in the construction and management of railways are very considerable.—All inequalities of surface in the line proposed must be removed—low parts filled up by embankments—high parts reduced—eminences which it would be impossible or too expensive to level, must be perforated by *tunnels*, and over dells and rivers viaducts require to be thrown, consisting, in some cases, of numerous arches. Beside, a previous survey must be made—the land over which it is to pass must be purchased sometimes at an exorbitant price—an act of parliament must be procured—and various petty and vexatious oppositions, arising from the avarice and obstinacy of landed proprietors, must be overcome, which not unfrequently add to all the other expenses. It has been estimated that, at an average, £30,000 per mile may be considered as a moderate outlay in the construction of railways throughout most parts of Great Britain. The London and Birmingham railway—a line extending 112 miles—

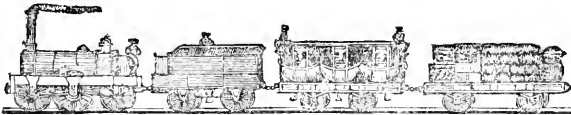

cost much more; its whole expense amounted to several millions of pounds. The least expensive railway we have yet heard of, is that between Dundee and Arbroath, the average expense of which per mile is estimated not to exceed £8000. The cost of a locomotive is about £1700, and it seldom wears longer than two years without undergoing an extensive repair. Ordinary locomotives evaporate 77 cubic feet of water per hour; those on the Great Western railway about 200 cubic feet. The evaporation of one cubic foot per hour produces a mechanical force of nearly 2 horse power; consequently we may ascertain the power of a locomotive by multiplying by 2 the number of cubic feet which it evaporates in an hour. An ordinary sized locomotive exerts a power of 150 horses; a horse upon a common road cannot draw for any length of time more than 15 hundred weight, while on a railway it will pull with equal ease ten tons, which is thirteen times the amount; and therefore the power of a locomotive such as is usually employed, is equal to a draught of 1462 tons.

The railways in most parts of Britain consist of two tracks, suitable for trains going in opposite directions; in America, Belgium, and other places, they consist generally of but one track. On most of the lines there are *slow* trains for goods and 2d class passengers—*fast* trains, taking only 1st and 2d class carriages—some lines have *mail* trains which proceed at more than usual speed, and stop at fewer places by the way. The 1st class carriages are covered—the 2d class carriages are open at the sides—and the 3d class carriages are entirely open, in some of which the passengers are obliged to *stand* during the journey, arising from a principle of avarice in the proprietors, and a foolish design of compelling, if possible, the lower classes to select the 1st and 2d class carriages. The carriages for goods are open on trucks, on which the articles are piled; and for cattle there are open trucks with a railing round the sides. All the carriages in a train—amounting in some cases to twenty or thirty—are linked

one to the other by strong iron hooks, and to prevent them from shocks against each other, the various carriages are provided with projecting rods on springs cushioned at the outer extremities. From one hundred to a thousand passengers are thus conveyed, at one time, from one city or town to another; and it is a universal rule that no servant or officer shall on any account take a fee from passengers, on pain of instant dismissal.

About 50 railways have been completed in the United Kingdom of Great Britain up to 1842.—The following are some of the principal lines—in England—The Liverpool and Manchester Railway, 32 miles in length, which cost £16,000 per mile; the London and Birmingham Railway, 112½ miles long, connecting the metropolis with the center of England, in which are several long and expensive tunnels, and which cost above £50,000 per mile; the Grand Junction Railway, 79 miles in length, connecting the London and Birmingham line to that of Liverpool and Manchester, and also to a railway proceeding northward to Lancaster, which cost £21,859 per mile, forming an important thoroughfare obliquely across the country; the Manchester and Leeds Railway, 50 miles in length; the Midland Counties, North Midland and Great North of England railways, connecting the great seats of trade in Northumberland, Durham, Yorkshire, and Derbyshire, with the London and Birmingham line; the Newcastle and Carlisle Railway, 61 miles long; the Great Western Railway, 117 miles long; which cost £53,241 per mile, and which connects London with Bristol and with smaller tributary lines opening up the west of England; the South-Western Railway, 77 miles long, connecting London with Southampton.—The principal lines of railway in Scotland are—The Edinburgh and Glasgow Railway, about 46 miles long, on which are several beautiful and extensive viaducts, which was opened in the beginning of 1842; the Glasgow and Ayr Railway, about 40 miles long; the Glasgow, Paisley, and Greenock, 22½ miles long; the Dundee, Newtyle, and Cupar-Angus railways,

about 17 miles long; the Dundee and Arbroath Railway, 17 miles in length; and the Arbroath and Forfar Railway, 15 miles long. Beside these, several others are projected, to connect Edinburgh and Newcastle, on the one hand, and with Dundee, Montrose, and Aberdeen, on the other. And we trust the period is not far distant, when every part of our country shall be intersected with these cheap and expeditious modes of conveyance.—The most prosperous of all the lines is that of the London and Birmingham, the *weekly* revenue of which is upward of £16,000; the weekly revenue of the Grand Junction, which joins it, is £900.—In the "Railway Magazine," July, 1842, the following calculation is given of a late weekly return of 40 railways, 1431 miles in length.—"Number of passengers on 25 railways, 289,819; consequently the total for the week, on the whole, must be about 400,000. The receipts for passengers on 39 railways, £74,938 15s. 6<sup>1</sup>/<sub>2</sub>d.; ditto for goods on 33 railways, £17,826 4s. 7<sup>1</sup>/<sub>2</sub>d.; total, £92,765 0s. 1<sup>1</sup>/<sub>2</sub>d. This is an average of £64 0s. 3<sup>1</sup>/<sub>4</sub>d. per mile, per week. The traffic, therefore, is at the rate of about four millions a year, and carrying fifteen millions of passengers."\*

The velocity with which railway trains generally proceed, is from 20 to 25 miles per hour; but on some of the English railways it is much more rapid. The lines upon which the trains travel with the greatest speed are as follows:—Average speed exclusive of stoppages—*Northern and Eastern Railway* 36 miles per hour; *Great Western Railway* 33; *London and Brighton* 30; *Newcastle and North Shields* 30; *Midland Counties* 29; *Northland* 29; *London and Birmingham* 27;—At the ordinary rate of speed, a journey from London to Liverpool by the mail train—a distance of about 210 miles—is performed in about 9 hours; and when railways shall be extended from the South to Edinburgh, the journey from that city to London may be accomplished in less than 18 hours; so that a person may leave Edinburgh at 6 in the morning, and take supper in London the same evening—a journey which not long ago, occupied nearly a fortnight.

Traveling on railways is on the whole attended with less danger than in stage-coaches or any other mode of conveyance. The personal injuries and loss of life, which have occurred chiefly on the English railways, are, without almost an exception, to be attributed, either to the ignorance and carelessness of the engine drivers, or to the imprudence and recklessness of those who have been the victims of accidents. Were men of superior intelligence and prudence always employed to direct the motions of the trains, and were the public at large to attend to the restrictions and regulations prescribed in reference to railways, almost every accident might be prevented. On the Dundee and Arbroath Railway, which has been in operation for four years, scarcely an accident has ever occurred to any of the passengers, and those few which have happened on that line were entirely owing to the folly and imprudence of those who were the victims.

The utility of Railway communication, when properly conducted, must be obvious to all. In a commercial country, such as ours, the rapid conveyance of goods of all descriptions from one town to another, is an object of peculiar importance. Even in agricultural districts, the formation of

railroads has enabled the landed proprietor to bring to a high state of cultivation extensive districts of land which would otherwise have remained barren and useless. But such advantages are as nothing, when compared with the increased diffusion of useful knowledge which must follow from a cheap and rapid conveyance over the British Empire, and over all those countries that have adopted similar modes of communication and transport.—Man is thus brought into juxta-position with his fellow-men; time and space are shortened, and cities a hundred miles distant may be considered as nearly adjacent, since they can be reached in the course of three or four hours. Friends, relatives, and correspondents can thus visit each other though at a distance, without much loss of time or money—communicate information, and interchange "brotherly kindness and affection." During the summer months, those confined in towns have an opportunity of taking excursions into the country for health and recreation, without any serious interference with the demands of business. Letters, newspapers, and periodicals of all descriptions, can be conveyed with a speed which, formerly, could neither have been effected nor anticipated. In certain cases, a letter may be written, sent through the Post-office, and delivered at the distance of 20 miles, in the course of a single hour. From Liverpool a letter may be dispatched to London, a distance of more than 200 miles, and an answer received in the course of the same day. As ignorance, superstition, and foolish prejudices, are the companions of those who live in retired districts, and seldom go beyond the view of the smoke of their father's chimney—so, when the great body of our fellow-men have an opportunity of taking extensive excursions through the country, we may expect that their minds will be expanded, their conceptions enlarged, and their views of nature and human society rendered more definite and extensive, so that they shall be enabled to take in ideas and portions of knowledge of which they were formerly ignorant. "Many shall run to and fro, and knowledge shall be increased." Beside, the frequent intercourse of man with his fellow-men of every grade has a natural tendency to promote friendship, esteem, and mutual affection. Civilization can alone be promoted by the frequent social intercourse of human beings; and wherever this intercourse exists, reciprocal benefits will always ensue; and such an intercourse among all ranks is now facilitated and promoted by the invention and formation of railways.

It is likewise obvious that Christianity and the Christian virtues may, by such improvements in traveling, be promoted and extended. "As in water face answereth to face, so doth the heart of man to man." In communicating religious instruction, admonition, and reproof, or in administering comfort under affliction, in most instances, the presence and countenance of a friend, and the living voice—breathing "words that burn," and which soothe or pierce the heart—generally produce a deeper and more permanent impression, where personal intercourse is obtained, than the same sentiments communicated by letter. "For as iron sharpeneth iron, so a man sharpeneth the countenance of his friend." We can also conceive many cases in which the labors of a minister of religion, and of a Christian missionary, may be greatly facilitated and rendered successful by a rapid conveyance from one place to another, and where missionary and other philanthropic associations would be more numerous attended and patronized by Christians having a cheap and ex-

\* The number of passengers booked for Edinburgh, at the several stations, on the Edinburgh and Glasgow Railway, on the 9th of August, 1842—the day of the Highland Society's exhibition—amounted to 4883.

peditions conveyance to the places in which they are held. In short, were such modes of traveling introduced into every country, we should quickly hear of what is passing in all parts of the world, and learn the aspect of the Divine dispensations toward all nations; we should learn, without loss of time, the result of all the missionary enterprises which have been undertaken for the conversion and renovation of the heathen world, and be in readiness to send forth, by a speedy course, other missionaries wherever they were wanted, to spread abroad the fame of the Redeemer, and the knowledge of that Revelation which points out the way to a blessed immortality.

In the preceding sketches I have presented a few specimens of the relation which the inventions of human ingenuity bear to religious objects. I intended to have traced the same relation in several other instances: in the invention of the electrical machine, the air-pump, mills, clocks, and watches, gas-lights, chemical fumigations, inventions for enabling us to walk upon the water, to prevent and alleviate the dangers of shipwreck, etc. But as my prescribed limits will not permit further enlargement, I trust that what has been already stated will be sufficient to establish and illustrate my general position. From this subject we may learn:—

1. That the various processes of art, and the exertions of human ingenuity, are under the special direction of Him who arranges all things "according to the counsel of his will." As "the king's heart is in the hand of the Lord, and as the rivers of waters he turns it whithersoever he pleases," so all the varied schemes and movements of the human mind, the discoveries of science, and the diversified experiments of mechanics, chemists, and philosophers, are directed in such channels as may issue in the accomplishment of His eternal purposes, in respect to the present and future condition of the inhabitants of our world. This truth is also plainly taught us in the records of Inspiration. "Doth the plowman plow all day to sow? Doth he open and break the clods of his ground? When he hath made plain the face thereof, doth he not cast abroad the vetches, and scatter the cummin,\* and cast in the wheat in the principal [place], and the barley in the appointed place, and the rye in its proper place? For his God doth instruct him to discretion, and doth teach him. This also cometh forth from the Lord of hosts, who is wonderful in counsel, and excellent in working." Agriculture has, by most nations, been attributed to the suggestions of Deity; for "every good and perfect gift cometh down from the Father of lights." It is he who hath taught men to dig from the bowels of the earth, iron, copper, lead, silver, and gold, and to apply them to useful purposes in social life, and who hath given them "wisdom and understanding" to apply the animal and vegetable productions of nature to the manufacture of cloths, linen, muslin, and silk, for the use and the ornament of man. For "all things are of God." "Both riches and honor come from him, and he reigneth over all, and in his hand is power and might, and in his hand it is to make great, and to give strength to all." When the frame of the Mosaic Tabernacle and all its curious vessels were to be constructed, the mind of Bezaleel "was filled with the Spirit of God, in wisdom and understanding, and in knowledge, and in all manner of

workmanship, to devise curious works in gold, and in silver, and in brass." And when the fabric of the New Testament Church is to be reared, and its boundaries extended, artificers of every description, adequate for carrying on the different parts of the work, are raised up, and inspired with the spirit of their respective departments—some with the spirit of writing, printing, and publishing; some with the spirit of preaching, lecturing, and catechising; some with the spirit of fortitude, to make bold and daring adventures into distant barbarous climes; and others with the spirit of literature, of science, and of the mechanical arts—*all acting as pioneers* "to prepare the way of the Lord," and as builders for carrying forward and completing the fabric of the Christian Church.

2. All the mechanical contrivances to which I have adverted, all the discoveries of science, and all the useful inventions of genius which may hereafter be exhibited, ought to be viewed as preparing the way for the *millennial era* of the church, and as having a certain tendency to the melioration of the external condition of mankind during its continuance. We are certain, from the very nature of things, as well as from scriptural prediction, that, when this period advances toward the summit of its glory, the external circumstances of this world's population will be comfortable, prosperous, and greatly meliorated, beyond what they have ever been in the days that are past—"Then shall the earth yield her increase, and God, even our own God, shall bless us." "Then shall he give the rain of thy seed, that thou shalt sow the ground withal; and bread of the increase of the earth, and it shall be fat and plenteous: in that day shall thy cattle feed in large pastures. The oxen likewise, and the young asses that ear the ground, shall eat savory provender, which hath been winnowed with a shovel and with the fan." "And the inhabitant shall not say, I am sick." "They shall build houses and inhabit them; and they shall plant vineyards, and eat the fruit of them. They shall not build, and another inhabit; they shall not plant, and another eat: for *as the days of a tree are the days of my people*, and mine elect shall long enjoy the work of their hands. They shall not labor in vain, nor bring forth for trouble; for they are the seed of the blessed of the Lord, and their offspring with them." "The seed shall be prosperous; the vine shall give her fruit, and the ground shall give her increase, and the heavens shall give their dew." "The evil beasts shall cease out of the land: and they shall sit every man under his vine, and under his fig-tree; and none shall make him afraid." "For wars shall cease to the ends of the world; and the knowledge of the Lord shall cover the earth, as the waters cover the sea."\* Diseases will be, in a great measure, banished from the world, and the life of man extended far beyond its present duration—agriculture will be brought to perfection—commodious habitations erected for the comfortable accommodation of all ranks—cities built on elegant and spacious plans, adapted to health, ornament and pleasure; divested of all the filth, and darkness and gloom, and narrow lanes, which now disgrace the abodes of men—roads will be constructed on improved principles, with comfortable means of retreat for shelter and accommodation at all seasons; and conveyances invented for the ease, and safety, and rapid conveyance of persons and property from one

\* *Vetches* is a kind of seed frequently sown in Judea, for the use of cattle; and *cummin* is the seed of a plant somewhat like fennel.

\* Psalm lxxvii. 6; Isaiah. xxx. 23, 24; xxxiii. 24; lxx. 21-23; Zech., viii. 12; Micah, iv. 4, etc.

place to another. Either the climates of the earth will be meliorated by the universal cultivation of the soil, so that storms and tempests, thunders and lightnings, shall no longer produce their present ravages; or chemical and mechanical contrivances will be invented to ward off their destructive effects. The landscape of the earth will be adorned with vegetable and architectural beauty; and, instead of horse-racing, demoralizing plays, routs and masquerades, boxing and bull-fights—artificial displays of scenery will be exhibited, more congenial to the dignity of rational, renovated, and immortal minds. For “the knowledge of the Lord,” and the “beauties of holiness,” will pervade men of all ranks and ages, “from the least even to the greatest.”\*

Now, as we have no reason to expect any *miraculous interference*, we must regard the past and the future useful inventions of philosophy and mechanics, as having a bearing on this glorious period, and a tendency to promote the improvement and the felicity of those who shall live during this era of Messiah’s reign. If diseases are to be generally abolished, it will be owing to the researches of the scientific physician in discovering certain antidotes against every disorder, and to the practice of temperance, meekness, equanimity, and every other mean of preserving the vigor of the animal frame. For vicious passions and pursuits are the source of numerous disorders which, along with the anxieties, perplexities, and remorse which accompany them, gradually prey upon the human frame, and cut short the period of human existence—while the regular exercise of faith, love, hope, joy, and other Christian graces have an evident tendency to promote both health and longevity. If the earth is to produce its treasures in abundance, and with little labor, it will be owing in part to the improvement of agricultural science, and of the instruments by which its operations are conducted. If the lightnings of heaven shall no longer prove destructive to man and to the labors

of his hands, it will be effected either by machinery for drawing off the electricity of a stormy cloud, or by the invention of *thunder-guards*, which shall afford a complete protection from its ravages. In these, and numerous other instances, the inventions of men, under the guidance of the Spirit of Wisdom, will have a tendency to remove a great part of the *curse* which has so long hung over our sinful world. And since the inventions of human skill and ingenuity for the melioration of mankind, and for the swift conveyance of intelligence, have of late years been rapidly increasing, *at the same time* when the Christian world is roused to increased exertions in disseminating the Scriptures throughout all lands, when general knowledge is increasingly diffused, and when the fabric of Superstition and Despotism is shaking to its foundations,—these combined and simultaneous movements seem plainly to indicate, that that auspicious era is fast hastening on, when “the glory of Jehovah shall be revealed, and all flesh shall see it together,” when “righteousness and praise shall spring forth before all nations,” and when “Holiness to the lord,” shall be inscribed on all the pursuits, and implements, and employments of men.

Lastly, If the remarks suggested above be well-founded, we may conclude, that the mechanical and philosophical inventions of genius are worthy of the attentive consideration of the enlightened Christian, particularly in the relation they may have to the accomplishment of religious objects. He should contemplate the experiments of scientific men, not as a waste of time, or the mere gratification of an idle curiosity, but as embodying the germs of those improvements by which civilization, domestic comfort, knowledge, and moral principle, may be diffused among the nations. To view such objects with apathy and indifference, as beneath the regard of a religious character, argues a weak and limited understanding, and a contracted view of the grand operations of a superintending Providence.

## CHAPTER IV.

### SCRIPTURAL DOCTRINES AND FACTS ILLUSTRATED FROM THE SYSTEM OF NATURE.\*

WITHOUT spending time in any introductory observations on this subject, it may be remarked in general,

I.—*That Scientific Knowledge, or an acquaintance with the System of Nature, may frequently serve as a guide to the true interpretation of Scripture.*

It may be laid down as a universal principle, that there can be no real discrepancy between a

just interpretation of Scripture, and the facts of physical science; and on this principle the following canon is founded, which may be considered as an infallible rule for Scripture interpretation, namely,—*That no interpretation of Scripture ought to be admitted which is inconsistent with any well authenticated facts in the material world. By well*

those diseases which now prey upon the human frame, and cut short its vital action, will be in a great measure extirpated. Both these effects may be viewed (without supposing any miraculous interference) as the natural consequence of that happiness and equanimity which will flow from the practice of Christian virtues, from the enlargement of our knowledge of the principles of nature, and from the physical enjoyments which such a state of society will furnish.

\* The various circumstances above stated, may be considered as the *natural results* of a state of society on which the light of science and of revelation has diffused its full influence, and where the active powers of the human mind are invariably directed by the pure principles and precepts of Christianity. That the duration of human life, at the era referred to, will be extended beyond its present boundary, appears to be intimated in some of the passages above quoted, particularly the following:—“*As the days of a tree shall be the days of my people, and mine elect shall long enjoy the work of their hands.*” And if the life of man will be thus protracted to an indefinite period, it will follow, that

Under this head it was originally intended to embrace an elucidation of a considerable variety of the facts recorded in the Sacred History, and of the allusions of the inspired writers to the system of Nature; but as the volume has already swelled beyond the limits proposed, I am reluctantly compelled to confine myself to the illustration of only two or three topics

*authenticated facts*, I do not mean the theories of philosophers, or the deductions they may have drawn from them, nor the confident assertions or plausible reasonings of scientific men in support of any prevailing system of Natural science; but those facts which are universally admitted, and the reality of which every scientific inquirer has it in his power to ascertain; such as, that the earth is not an extended plane, but a round or globular body, and that the rays of the sun, when converged to a focus by a large convex glass, will set fire to combustible substances. Such facts, when ascertained, ought to be considered as a revelation from God, as well as the declarations of his word. For they make known to us a portion of his character, of his plans and of his operations.—This rule may be otherwise expressed as follows:—*Where a passage of Scripture is of doubtful meaning, or capable of different interpretations, that interpretation ought to be preferred which will best agree with the established discoveries of science.* For, since the Author of Revelation and the Author of universal nature is one and the same Infinite Being, there must exist a complete harmony between the revelations of his Word, and the facts or relations which are observed in the material universe. To suppose the contrary, would be to suppose the Almighty capable of inconsistency; a supposition which would go far to shake our confidence in the theology of Nature, as well as of Revelation. If, in any one instance, a Record claiming to be a revelation from heaven, were found to contradict a well known fact in the material world; if, for example, it asserted in express terms, to be literally understood, that the earth is a *quiescent* body in the center of the universe, or that the moon is no larger than a mountain—it would be a fair conclusion, either that the revelation is not Divine—or that the passages embodying such assertions are interpolations—or that science, in reference to these points, has not yet arrived at the truth. The example, we are aware, is inapplicable to the Christian revelation, which rests securely on its own basis, and to which science is gradually approximating, as it advances in the amplitude of its views, and the correctness of its deductions; but it shows us how necessary it is, in interpreting the *Word of God*, to keep our eye fixed upon his *Works*; for we may rest assured, that *truth* in the one will always correspond with *fact* in the other.

To illustrate the rule now laid down, an example or two may be stated.—If it be a fact, that geological research has ascertained that the materials of the strata of the earth are of a more ancient date than the Mosaic account of the commencement of the present race of men—the passages in the first chapter of Genesis, and other parts of Scripture, which refer to the origin of our world, must be explained as conveying the idea, that the earth was then merely *arranged* into its present form and order, out of the materials which *previously existed*, and which had been created by the Almighty at a period prior in duration. For Moses nowhere asserts that the materials of our globe were created or brought into existence out of nothing, at the time to which his history refers; but insinuates the contrary. “For the earth,” says he, prior to its present constitution, “*was without form and void,*” etc.—Again, if it be a fact that the universe is indefinitely extended, that, of many millions of vast globes which diversify the voids of space, only two or three have any immediate connection with the earth—then it will appear most reasonable to conclude, that those expressions in the Mosaic history

of the creation, which refer to the creation of the fixed stars, are not to be understood as referring to the *time* when they were brought into existence, as if they had been created about the same time with our earth; but as simply declaring the fact, that, at what period soever in duration they were created, *they derived their existence from God.* That they did not all commence their existence at that period, is demonstrable from the fact, that, within the space of 2000 years past, and even within the space of the last two centuries, new stars have appeared in the heavens, which previously did not exist in the concave of the firmament; which, consequently, have been created since the Mosaic period; or, at least, had undergone a change analogous to that which took place in our globe, when it emerged from a chaotic state, to the form and order in which we now behold it. Consequently, the phrase, “God rested from all his works,” must be understood, not absolutely, or in reference to the whole system of nature, but merely in relation to our world; and as importing, that the Creator then ceased to form any new species of beings on the *terrestrial globe*.—The same canon will direct us in the interpretation of those passages which refer to the last judgment, and the destruction of the present constitution of our globe. When, in reference to these events, it is said, that “the stars shall fall from heaven,” that “the powers of heaven shall be shaken,” and that “the earth and the heaven shall flee away,” our knowledge of the system of nature leads us to conclude, either that such expressions are merely metaphorical, or that they describe only the *appearance*, not the *reality* of things. For it is impossible that the stars can ever fall to the earth, since each of them is of a size vastly superior to our globe, and could never be attracted to its surface, without unhooking the laws and the fabric of universal nature. The *appearance*, however, of the “heaven fleeing away,” would be produced, should the earth’s diurnal rotation, at that period, be suddenly stopped, as will most probably happen; in which case, all nature, in this sublunary system, would be thrown into confusion, and the heavens, with all their host, would *appear* to flee away.

Now, the scientific student of Scripture alone can judiciously apply the canon to which I have adverted; he alone can appreciate its utility in the interpretation of the sacred oracles; for he knows the facts which the philosopher and the astronomer have ascertained to exist in the system of nature; from the want of which information many divines, whose comments on Scripture have, in other respects, been judicious, have displayed their ignorance, and fallen into egregious blunders, when attempting to explain the first chapters of Genesis, and several parts of the book of Job—which have tended to bring discredit on the oracles of heaven.

## II.—*The System of Nature confirms and illustrates the Scriptural Doctrine of the DEPRAVITY OF MAN.*

In the preceding parts of this volume, I have stated several striking instances of Divine benevolence, which appear in the construction of the organs of the animal system, in the constitution of the earth, the waters, and the atmosphere, and in the *variety* of beauties and sublimities which adorn the face of nature; all which proclaim, in language which can scarcely be mistaken, that the Creator has a special regard to the happiness of his creatures. Yet the Scriptures uniformly declare, that man has fallen from his primeval state of inno-

cence, and has violated the laws of his Maker; that "his heart is deceitful above all things, and desperately wicked;" and that "destruction and misery are in his ways." Observation and experience also demonstrate, that a moral disease pervades the whole human family, from the most savage to the most civilized tribes of mankind; which has displayed its virulence in those wars and devastations which have, in all ages, convulsed the world; and which daily displays itself in those acts of injustice, fraud, oppression, malice, tyranny, and cruelty, which are perpetrated in every country, and among all the ranks even of civilized life. That a world inhabited by moral agents of this description, would display, in its physical constitution, certain indications of its Creator's displeasure, is what we should naturally expect, from a consideration of those attributes of his nature with which we are acquainted. Accordingly we find, that, amidst all the evidences of benevolence which our globe exhibits, there are not wanting certain displays of "the wrath of Heaven against the ungodliness and unrighteousness of men," in order to arouse them to a sense of their guilt, and to inspire them with reverence and awe of that Being whom they have offended. The following facts, among many others, may be considered as corroborating this position.

In the first place, *The present state of the interior strata of the earth* may be considered as a presumptive evidence, that a moral revolution has taken place since man was placed upon the globe. When we penetrate into the interior recesses of the earth, we find its different strata bent in the most irregular forms; sometimes lying horizontally, sometimes projecting upward, and sometimes downward, and thrown into confusion; as if some dreadful concussion had spread its ravages through every part of the solid crust of our globe. This is visible in every region of the earth. Wherever the miner penetrates among his subterraneous recesses, wherever the fissures and caverns of the earth are explored, and wherever the mountains lay bare their rugged cliffs, the marks of ruin, convulsion, and disorder, meet the eye of the beholder. Evidences of these facts are to be found in the records of all intelligent travelers and geologists who have visited Alpine districts, or explored the subterraneous regions of the earth; of which I have already stated a few instances in the article *Geology*.—These facts seem evidently to indicate, that the earth is not now in the same state in which it originally proceeded from the hand of its Creator; for such a scene of disruption and derangement appears incompatible with that order, harmony, and beauty, which are apparent in the other departments of nature. We dare not assert, that such terrible convulsions took place by chance, or independent of the will of the Creator; nor dare we insinuate, that they were the effects of a random display of Almighty power; and, therefore, we are necessarily led to infer, that a moral cause connected with the conduct of the rational inhabitants of the globe, must have existed, to warrant so awful an interposition of Divine Power; for the fate of the animated beings which then peopled the earth, was involved in the consequences which must have attended this terrible catastrophe. The volume of Revelation on this point, concurs with the deductions of reason, and assigns a cause adequate to warrant the production of such an extraordinary effect. "The wickedness of man was GREAT upon the earth; the earth was FILLED WITH VIOLENCE; every purpose and desire of man's heart was ONLY EVIL CONTINUALLY." Man had frustrated the end of his

existence; the earth was turned into a habitation of demons; the long period to which his life was protracted, only served to harden him in his wickedness, and to enable him to carry his diabolical schemes to their utmost extent, until the social state of the human race became a scene of unmingled depravity and misery. And the physical effects of the punishment of this universal defection from God, are presented to our view in every land, and will remain to all ages, as a visible memorial that man has rebelled against the authority of his Maker.\*

2. *The existence of volcanoes and the terrible ravages they produce*, bear testimony to the state of man as a depraved intelligence. A volcano is a mountain generally of an immense size, from whose summit issue fire, smoke, sulphur, and torrents of melted lava.† Previous to an eruption, the smoke, which is continually ascending from the crater, or opening in the top, increases and shoots up to an immense height; forked lightning issues from the ascending column; showers of ashes are thrown out to the distance of forty or fifty miles; volleys of red-hot stones are discharged to a great height in the air; the sky appears thick and dark; the luminaries of heaven disappear; and these terrible forebodings are accompanied with thunder, lightning, frequent concussions of the earth, and dreadful subterraneous bellowings. When these alarming appearances have continued sometimes four or five months, the lava begins to make its appearance, either boiling over the top, or forcing its way through the side of the mountain. This fiery deluge of melted minerals rolls down the declivity of the mountain, forming a dismal flaming stream, sometimes fourteen miles long, six miles broad, and 200 feet deep. In its course it destroys orchards, vineyards, corn-fields, and villages; and sometimes cities, containing twenty thousand inhabitants, have been swallowed up and consumed. Several other phenomena, of awful sublimity, sometimes accompany these eruptions. In the eruption of Vesuvius, in 1794, a shock of an earthquake was felt; and, at the same instant, a fountain of bright fire, attended with the blackest smoke and a loud report, was seen to issue, and to rise to a great height from the cone of the mountain; and was soon succeeded by fifteen other fiery fountains, all in a direct line, extending for a mile and a half downward. This fiery scene was accompanied with the loudest thunder, the incessant reports of which, like those of a numerous heavy artillery, were attended by a continued hollow murmur, similar to that of the roaring of the ocean during a violent storm. The houses in Naples, at seven miles distance, were for several hours in a constant tremor; the bells ringing, and doors and windows incessantly rattling and shaking. The murmur of the prayers and lamentations of a numerous population added to the hor-

\* It is not meant here to insinuate that all the dislocations and irregularities found in the strata of the earth are to be attributed to the action of the deluge; but it can scarcely be called in question, that certain traces of the effects of this catastrophe are to be found in most countries. The simple fact recorded in Revelation, that "the fountains of the great deep were broken up, and the flood-gates of the heavens opened"—that "the storm of rain continued upon the earth forty days and forty nights," and that the earth was covered 1 with water for nearly the space of a whole year—could not but produce a very sensible and extensive effect upon the solid parts of the globe, though it may be difficult in some instances to magnify some of the effects produced by Noah's flood from those which were the result of previous catastrophes. At any rate, the sacred historian is explicit in declaring it was "because the wickedness of man was great," that "a flood of waters was brought upon the earth."

† See page 53.

rors of the scene. All travelers who have witnessed these eruptions seem to be at a loss to find words sufficiently emphatic to express the terrors of the scene. "One cannot form a juster idea," says Bishop Berkley, "of the noise emitted by the mountain, than by imagining a mixed sound made up of the raging of a tempest, the murmur of a troubled sea, and the roaring of thunder and artillery, confused altogether. Though we heard this at the distance of twelve miles, yet it was very terrible." In 1744, the flames of Cotopaxi, in South America, rose 3000 feet above the brink of the crater, and its roarings were heard at the distance of six hundred miles. "At the port of Guayaquil, 150 miles distant from the crater," says Humboldt, "we heard day and night the noise of this volcano, like continued discharges of a battery, and we distinguished these tremendous sounds even on the Pacific ocean."

The most terrific and extraordinary volcano yet known is that of Kirauca, lately discovered in Hawaii, one of the Sandwich islands. When the crater of this volcano first bursts upon the sight, there is an appearance presented of an immense plain below, 15 or 16 miles in circumference, and from 200 to 400 feet below its original level, covered with hillocks of lava, and vast floods of burning matter in a state of terrific ebullition, moving to and fro its fiery surge and flaming billows. Mr. Ellis, who beheld this volcano, states that, around the edge, or from the surface of the burning lake, there arose no fewer than 51 conical islands of varied form and size, containing as many craters. Twenty-two were constantly emitting columns of gray smoke or pyramids of brilliant flame, and several of these at the same time vomited from their ignited mouths streams of lava which rolled in blazing torrents down their black indented sides into the boiling mass below. The roar and noise emitted from these several craters resemble the sounds of a mighty steam-engine—a whole lake of fire appearing in the distance—billow after billow tossing its monstrous bosom in the air, and throwing forth its fiery spray to the height of 40 or 50 feet—forming a scene most awfully grand and terrific—flames bursting forth from the largest cone, red-hot stones, cinders, and ashes propelled to a mighty height with immense violence, and appalling floods of lava boiling down the sides over the surrounding scoria. Mr. Stewart and a party from the Blonde frigate visited this volcano in 1825. The following is only a very small part of his description:—"At night, splendid illuminations were lighted up; the volcano began roaring and laboring with redoubled activity. The confusion of noises was prodigiously great—rolling from one end of the crater to the other, sometimes seeming to be immediately under us, when a sensible tremor of the ground took place, and then again rushing to the farther end with incalculable velocity. The whole air was filled with the tumult, and soon after flames burst from a large cone near which we had been in the morning. Red-hot stones, cinders, and ashes were also propelled to a great height with immense violence, and shortly after the molten lava came boiling up and flowed down the sides of the cone and over the surrounding scoria, in two beautiful streams, glittering with indescribable brilliance. At the same time, a whole lake of fire opened in a more distant part; this could not have been less than two miles in circumference; and its action was more horribly sublime than anything I ever imagined to exist, even in the ideal visions of unearthly things." This fiery volcano of Kirauca,

the largest of which we have any record, dwindles into insignificance, when we think of the probable subterranean fires immediately beneath the whole of these and other South-Sea islands. The whole of Hawaii (Owhyhee), covering a space of 4000 square miles, is a complete mass of lava or other volcanic matter in various stages of decomposition. Perforated with innumerable apertures in the shape of craters, it forms a hollow cone over one vast furnace, situated in the heart of a stupendous submarine mountain rising from the bottom of the sea. When we contemplate such awful and overwhelming phenomena, the workmanship of Him who laid the foundations of the earth, and who superintends the operation of all its elementary principles, we have reason to exclaim, "Let the nations say unto God, how terrible art thou in thy works! Let all the earth fear Jehovah; let all the inhabitants of the world stand in awe of him!"

The ravages produced by volcanoes are in proportion to the terror they inspire. In the eruption of Etna in 1669, the stream of lava destroyed, in forty days, the habitations of 27,000 persons; and, of 20,000 inhabitants of the city of Catania, only 3000 escaped. In the year 79, the celebrated cities of Pompeii and Herculaneum were completely overwhelmed and buried under ground by an eruption of Vesuvius, and the spots on which they stood remained unknown for 1600 years. Since that period, about forty eruptions have taken place, each of them producing the most dreadful ravages. But the volcanoes of Asia and America are still more terrible and destructive than those of Europe. The volcanic mountain Pichincha, near Quito, caused, on one occasion, the destruction of 25,000 inhabitants. In the year 1772, an eruption of a mountain in the island of Java destroyed forty villages, and several thousands of the inhabitants; and in October, 1822, eighty-eight hamlets and above 2000 persons were destroyed in the same island, by a sudden eruption from a new volcano. The eruption from Tomboro, in the island of Sumbawa, in 1815, was so dreadful that all the Moluccas, Java, Sumatra, and Borneo, to the distance of a thousand miles from the mountain, felt tremulous emotions, and heard the report of explosions. In Java, at the distance of 340 miles, the clouds of ashes from the volcano produced utter darkness.

Volcanoes are more numerous than is generally imagined. They are to be found in every quarter of the world, from the icy shores of Kamtschatka to the mountains of Patagonia. Humboldt enumerates forty volcanoes constantly burning between Cotopaxi and the Pacific ocean; twenty have been observed in the chain of mountains that stretches along Kamtschatka; and many of them are to be seen in the Philippines, the Moluccas, the Cape de Verd, the Sandwich, the Ladrone, and other islands in the Indian and Pacific oceans. It is stated in vol. 6th of *Supp. to Encyc. Brit.*, that about 205 volcanoes are known, including only those which have been active within a period to which history or tradition reaches. Europe contains 14; and, of the whole number, it is computed that 107 are in islands, and 98 on the great continents.

Can we then suppose that so many engines of terror and destruction, dispersed over every quarter of the globe, are consistent with the conduct of a benevolent Creator toward an innocent race of men? If so, we must either admit that the Creator had it not in his power, when arranging our terrestrial system, to prevent the occasional action of these dreadful ravages; or, that he is

indifferent to the happiness of his innocent offspring. The former admission is inconsistent with the idea of his Omnipotence, and the latter with the idea of his universal Benevolence. It is not, therefore, enthusiasm, but the fairest deduction of reason to conclude, that they are indications of God's displeasure against a race of transgressors who have apostatized from his laws.

3. The same reasoning will apply to the ravages produced by *Earthquakes*. Next to volcanoes, earthquakes are the most terrific phenomena of nature, and are even far more destructive to man, and to the labors of his hands. An earthquake, which consists in a sudden motion of the earth, is generally preceded by a rumbling sound, sometimes like that of a number of carriages driving furiously along the pavement of a street, sometimes like the rushing noise of a mighty wind, and sometimes like the explosions of artillery. Their effect on the surface of the earth is various. Sometimes it is instantaneously heaved up in a perpendicular direction, and sometimes it assumes a kind of rolling motion, from side to side.—The ravages which earthquakes have produced are terrible beyond description; and are accomplished almost in a moment. In 1692, the city of Port-Royal, in Jamaica, was destroyed by an earthquake, in the space of two minutes, and the houses sunk into a gulf forty fathoms deep. In 1693, an earthquake happened in Sicily, which either destroyed or greatly damaged fifty-four cities and an incredible number of villages. The city of Catania was utterly overthrown; the sea all of a sudden began to roar; Mount Etna to send forth immense spires of flame; and, immediately a shock ensued, as if all the artillery in the world had been discharged. The birds flew about astonished; the sun was darkened; the beasts ran howling from the hills; a dark cloud of dust covered the air; and though the shock did not last three minutes, yet nineteen thousand of the inhabitants of the city perished in the ruins. This shock extended to a circumference of 7000 miles.

Earthquakes have been producing their ravages in various parts of the world, and in every age, and are still continuing their destructive effects. Pliny informs us, that twelve cities in Asia Minor were swallowed up in one night. In the year 115, the city of Antioch, and a great part of the adjacent country, were buried by an earthquake. About 300 years after, it was again destroyed along with 40,000 inhabitants; and, after an interval of only 60 years, it was a third time overturned, with the loss of not less than 60,000 souls. In 1755, Lisbon was destroyed by an earthquake, and it buried under its ruins above 50,000 inhabitants. The effects of this terrible earthquake were felt over the greater part of Europe and Africa, and even in the midst of the Atlantic ocean; and are calculated to have extended over a space of not less than four millions of square miles. In August, 1822, two-thirds of the city of Aleppo, which contained 40,000 houses, and 200,000 inhabitants, were destroyed by an earthquake, and nearly 30,000 inhabitants were buried under the ruins.—On the 7th May, 1842, at 5 o'clock in the evening, the town of Cape Haytien, in the island of St. Domingo, was totally destroyed by an earthquake, and ten thousand of the inhabitants—forming two-thirds of the population—perished in the catastrophe. The towns of St. Nicholas and Port Paix, were also tumbled into ruins, and most if not all towns on the north side of the island, in some of which multitudes of the inhabitants were destroyed, amounting in all to about 20,000 human beings, who perished in that

tremendous concussion. Its effects were traced from W. Longitude 56° in the northern part of the tropics, to W. Longitude 91°, comprehending an extent, from east to west, of 35°, passing along Cuba, Louisiana, and part of the United States.

To suppose that the human beings who have been victims to the ravages of earthquakes and volcanoes, "were sinners above all those who dwelt around them," would be the height of impiety and presumption. But the fact, that thousands of rational beings have been swept from existence, in a manner so horrible and tremendous, seems plainly to indicate, that they belonged to a race of apostate intelligences, who had violated the commands of their Creator. Such visitations are quite accordant to the idea of man being in the condition of a transgressor; but, if he were an *innocent* creature, they would be altogether unaccountable, as happening under the government of a Being of unbounded benevolence.

4. The phenomena of *thunder-storms*, *tempests*, and *hurricanes*, and the ravages they produce, are also presumptive proofs that man is a depraved intelligence. In that season of the year when Nature is arrayed in her most beautiful attire, and the whole terrestrial landscape tends to inspire the mind with cheerfulness—suddenly a sable cloud emerges from the horizon—the sky assumes a baleful aspect—a dismal gloom envelops the face of Nature—the lightnings flash from one end of the horizon to another—the thunders roll with awful majesty along the verge of heaven, until at length they burst over head in tremendous explosions. The sturdy oak is shattered and despoiled of its foliage; rocks are rent into shivers; and the grazing herds are struck into a lifeless group. Even *man* is not exempted from danger in the midst of this appalling scene. For hundreds in every age have fallen victims either to the direct stroke of the lightning, or to the concussion and conflagrations with which it has been attended. In tropical countries, the phenomena of *thunder-storms* are more dreadful and appalling than in our temperate climate. The thunder frequently continues for days and weeks in almost one incessant roar; the rains are poured down in torrents; and the flashes of lightning follow each other in so rapid a succession, that the whole atmosphere and the surrounding hills seem to be in a blaze. In some instances, the most dreadful effects have been produced by the bursting of an electrical cloud. In 1772, a bright cloud was observed at midnight to cover a mountain in the island of Java; it emitted globes of fire so luminous that the night became as clear as day. Its effects were astonishing. Everything was destroyed for seven leagues around; houses were demolished; plantations buried in the earth; and 2149 people lost their lives, beside 1500 head of cattle, and a vast number of horses and other animals.\*

Is it not reasonable, then, to conclude, that such awful phenomena as storms, volcanoes, and earthquakes are so many occasional indications of the frown of an offended Creator upon a race of transgressors, in order to arouse them to a sense of their apostasy from the God of heaven? We cannot conceive that such physical operations, accompanied by so many terrific and destructive effects, are at all compatible with the idea, that man is at present in a *paradisical* state, and possessed of that *moral* purity in which he was created. Such appalling displays of Almighty power are in complete unison with the idea, that man is a transgressor, and that the present dispensations

\* Encyc. Brit., Art. Cloud



of God are a mixture of mercy and of judgment; but if he belong to an innocent race of moral intelligences, they appear quite anomalous, and are altogether inexplicable, on the supposition, that a Being of infinite benevolence and rectitude directs the operations of the physical and moral world; more especially when we consider the admirable care which is displayed in the construction of animal bodies, in order to prevent pain, and to produce pleasurable sensations. When man was first brought into existence, his thoughts and affections, we must suppose, were in unison with the will of his Creator; his mind was serene and unruffled; and, consequently, no foreboding apprehensions of danger, would, in such a state, take possession of his breast. But after he had swerved from the path of primeval rectitude, and especially after the Deluge had swept away the inhabitants of the Antediluvian world, the constitution of the earth and the atmosphere seems to have undergone a mighty change, corresponding to the degraded state into which he had fallen; so that those very elements which may have formerly ministered to his enjoyment—by being formed into different combinations—now conspire to produce terror and destruction.

The same important conclusion might have been deduced, from a consideration of the immense deserts of marshes and barren sands which are dispersed over the globe—the vast and frightful regions of ice around the poles—the position of the mineral strata, and the vast disproportion which the extent of the dry land bears to the expanse of the ocean,—all which circumstances, and many others, in conjunction with the facts above stated, conspire to show, that man no longer stands in the rank of a pure intelligence; and that his habitation corresponds, in some degree, to his state of moral degradation. By overlooking this consideration, St. Pierre and other Naturalists have found themselves much at a loss, when attempting to vindicate the wisdom and equity of Providence, in the physical disorders which exist in the present constitution of our globe. The circumstance, that man is a fallen creature, appears the only clue to guide us in unraveling the mysteries of Providence, and to enable us to perceive the *harmony and consistency* of the Divine operations in the system of nature; and no other consideration will fully account for the disorders which exist in the present economy of our world.

But it is a most consoling consideration, that, amidst all the physical evils which abound, the benevolence and mercy of God are admirably blended with the indications of his displeasure.—Thunder-storms and tempests contribute to the purification of the atmosphere; and volcanoes are converted into funnels for vomiting up those fiery materials which produce earthquakes, and which might otherwise swallow up whole provinces in one mighty gulf. In the *ordinary course* of things, such phenomena are more terrific than destructive; and are calculated rather to rouse an unthinking world to consideration, than to prove the instruments of human destruction. Compared with the miseries which men have voluntarily inflicted on one another, the destructive effects of the elements of nature dwindle into mere temporary and trifling accidents. We have reason to believe, that a much greater destruction of human beings has been produced by two or three of the late battles in modern Europe, such as those of Waterloo, Borodino, and Smolensko, than has been produced by all the electrical storms, earthquakes, and volcanic eruptions, which have raged for the space

of several hundred years. It has been calculated, that, during the Russian campaign of 1812, including men, women, and children, belonging to the French and Russians, there were not less than five hundred thousand human victims sacrificed to the demon of war. It is probable, that the destruction produced among the human race, by the convulsions of nature, since the commencement of time (the deluge only excepted), does not amount to above four or five millions of lives; but were we to take into account the destruction of human life produced by ambition, tyranny, oppression, superstition, wars, devastations, murders, and horrid cruelties, in every period of the world, it would, doubtless, amount to several thousands of millions. So that, amidst the most terrible displays of the displeasure of God against the sins of men, *mercy* is mingled with judgment; and while man is the greatest enemy and destroyer of his own species, benevolence is the *prominent* feature of all the arrangements of the Deity in the physical world. For although he is great in power he is slow to anger, and “his tender mercies are over all his works.” The evils which flow from the operation of the elements of nature ought not to be considered as the inflictions of avenging justice, but as the kind admonitions of a benevolent Father, who willeth not that any should perish, but that all should come to repentance—and who has displayed his love to the human race in such a wonderful manner that “he gave his only-begotten Son, that whosoever believeth on him might not perish but have everlasting life.”\*

### III.—*The Discoveries which have been made in the System of Nature illustrate the Doctrine of the RESURRECTION OF THE DEAD.*

The doctrine of a Resurrection from the dead, at first view, appears to involve in it a variety of difficulties and apparent contradictions. That a complex organical machine, as the human body is, consisting of thousands of diversified parts for the performance of its functions, after it has been reduced to atoms, and those atoms dispersed to “the four winds of heaven”—should be again reared up with the same materials, in a new and more glorious form,—is an idea which seems to baffle human comprehension; and, in all probability, would never have entered the mind of man, had it not been communicated by Divine Revelation. Accordingly we find, that the philosophers of antiquity, though many of them believed in the doctrine of a future state, never once dreamed that the bodies of men, after they had been committed to the dust, would ever again be reanimated: and hence, when the Apostle Paul proposed this doctrine to the Athenian philosophers, they scouted the idea, as if it had been the reverie of a madman. And, indeed, without a strong conviction, and a lively impression, of the infinite power and intelligence of God, the mind cannot rely with unshaken confidence on the declaration of a future fact so widely different from all the obvious phenomena of nature, and from everything that lies within the range of human experience. “If a man die,” says Job, “shall he live again? There is hope of a tree, if it be cut down, that it will sprout again, and bring forth

\* The facts stated in this section are expressed, for the most part, in the author's own words, for the sake of compression—His authorities are, Goldsmith's *Natural History*, Humboldt's *Travels*, Brydon's *Tour*, Sir W. Hamilton's *Observations*, Raffle's *History of Java*, *Encyc. Brit.*, *Arts. Etas.*, *Volcano*, *Earthquake*, *Antioch*, *Cloud*—Ellis's *Polynesian Researches*, etc.

boughs like a plant. But man dieth and wasteth away; yea, man giveth up the ghost, and where is he?" When the mind, however, is frequently exercised in contemplations on the stupendous works of the Almighty, it must feel an impressive conviction, that "nothing can be too hard for Jehovah." When we endeavor to draw aside the veil which conceals many of the scenes of nature from the vulgar eye, we perceive a variety of operations and analogies, which tend to assist us in forming a conception, not only of the possibility of a resurrection, but also of the manner in which it may probably be effected, when the power of Omnipotence is interposed.

The transformation of insects affords us a beautiful illustration of this subject. All the butterflies which we see fluttering about in the summer months were originally caterpillars. Before they arrive at that highest stage of their existence, they pass through four different transformations. The first state of a butterfly is that of an egg; it next assumes the form of a loathsome crawling worm; after remaining some time in this state, it throws off its caterpillar skin, languishes, refuses to eat, ceases to move, and is shut up, as it were, in a tomb. In this state, the animal is termed a *chrysalis*: it is covered with a thin crust or shell, and remains, sometimes for six or eight months, without motion, and apparently without life. After remaining its allotted time in this torpid condition, it begins to acquire new life and vigor; it bursts its imprisonment, and comes forth a butterfly, with wings tinged with the most beautiful colors. It mounts the air, it ranges from flower to flower, and seems to rejoice in its new and splendid existence. How very different does it appear in this state, from what it did in the preceding stages of its existence! How unlikely did it seem, that a rough, hairy, crawling worm, which lay for such a length of time, in a death-like torpor, and enshrouded in a tomb, should be reanimated, as it were, and changed into so beautiful a form, and indued with such powers of rapid motion! Perhaps the change to be effected on the bodies of men, at the general resurrection, may not be greater, nor more wonderful in its nature, than are the changes which take place from the first to the last stage of a caterpillar's existence.—In such transformations, then, we behold a lively representation of the death and resurrection of a righteous man. "A little while he shall lie in the ground, as the seed lies in the bosom of the earth; but he shall be raised again, and shall never die any more."

There is another illustration, taken from a consideration of the chemical changes of matter, which has a still more direct bearing on the doctrine of a resurrection. We know, that substances which are invisibly incorporated with air, water, and other fluids, and which seem to be destroyed, may be made to reappear in their original form by the application of certain chemical reagents. For example, put a small piece of solid camphor into a vial half filled with alcohol or spirit of wine—in a short time the camphor will be dissolved in the fluid, and the spirit will be as transparent as at first. If water be now added, it will unite with the ardent spirit, and the camphor will be separated and fall to the bottom of the vial. In this way the camphor may be nearly all recovered as at first; and, by distillation, the alcohol may also be separated from the water, and exhibited in a separate state. I have already noticed that carbon, which forms an essential part of all animal and vegetable substances, is found to be not only indestructible by age, but in all its com-

binations, which are infinitely diversified, it still preserves its identity. In the state of carbonic acid, it exists in union with earths and stones in unbounded quantities; and, though buried for thousands of years beneath immense rocks, or in the center of mountains, it is still carbonic acid: for no sooner is it disengaged from its dormitory, than it rises with all the life and vigor of recent formation, not in the least impaired by its torpid inactivity during the lapse of ages. The beams of the theater at Herculaneum were converted into charcoal (which is one of the compounds of carbon), by the lava which overflowed that city during an eruption of mount Vesuvius; and, during the lapse of 1700 years, the charcoal has remained as entire as if it had been formed but yesterday, and it will probably continue so to the end of the world. In addition to these facts, it may be stated that provision has been made for the restoration of the fallen leaves of vegetables which rot upon the ground, and to a careless observer, would appear to be lost forever. It has been shown by experiment that, whenever the soil becomes charged with such matter, the oxygen of the atmosphere combines with it, and converts it into carbonic acid gas. The consequence of which is, that *this very same carbon* is, in process of time, absorbed by a new race of vegetables, which it clothes with a new foliage, and which is itself destined to undergo similar putrefaction and renovation to the end of time.\*

These facts, and others of a similar description, which might have been stated, demonstrate, that one of the constituent parts of animal bodies remains unalterably the same amidst all the revolutions of time, and all the changes and decompositions which take place in the system of nature; and, consequently that though human bodies may remain in a state of putrefaction for ages, in the earth and in the waters, yet their component parts remain unchanged, and in readiness to enter into a new and more glorious combination, at the command of that INTELLIGENCE, to whom all the principles of nature, and all their diversified changes, are intimately known; and whose power is able to direct their combinations to the accomplishment of his purposes.—Though such considerations as these may have no weight on certain unreflecting minds, that never met with any difficulties in the economy either of Nature or of Redemption—yet the man of deep reflection, who has frequently had his mind distracted with the apparent improbability of the accomplishment of certain divine declarations, will joyfully embrace such facts in the economy of nature, as a *sensible support* to his faith in the promises of his God; and will resign his body to dust and putrefaction, in the firm hope of emerging from the tomb to a future and more glorious transformation.

#### IV.—*The Discoveries of Science tend to illustrate the Doctrine of the GENERAL CONFLAGRATION.*

We are informed, in the Sacred Oracles, that a period is approaching, when "the elements shall melt with fervent heat, and the earth, and the works that are therein, shall be burned up." Science has ascertained certain facts in the constitution of nature, which lead us to form some conception of the manner in which this awful catastrophe may probably be effected, and also of the ease with which it may be accomplished, when the destined period shall have arrived. It was formerly stated (pp. 32, 105), that the atmosphere,

\* Parke's Chemical Catechism, p. 266, and the additional Notes.

or the air we breathe, is a compound substance, composed of two very different and opposite principles, termed *oxygen* and *nitrogen*. The oxygen, which forms about a fifth part of the atmosphere, is now ascertained to be the principle of flame: a lighted taper, immersed in this gas, burns with a brilliancy too great for the eye to bear; and even a rod of iron or steel is made to blaze under its energy.

The modern infidel, like the scoffers of old, scorns the idea of the dissolution of the world, and of the restitution of the universe, because all things continue as they were from the beginning of the creation; not knowing the Scriptures, nor the Power of God; and not considering the principles and facts in the system of nature, which indicate the possibility of such an event. But, from the fact now stated, we may learn, how easily this effect may be accomplished, even in conformity with those laws which now operate in the constitution of our globe. For, should the Creator issue forth his Almighty fiat—"Let the nitrogen of the atmosphere be completely separated from the oxygen, and let the oxygen exert its native energies without control, wherever it extends;"—from what we know of its nature, we are warranted to conclude, that instantly a universal conflagration would commence throughout all the kingdoms of nature—not only wood, coals, sulphur, bitumen, and other combustible substances, but even the hardest rocks and stones, and all the metals, fossils, and minerals, and water itself, which is a compound of two inflammable substances, would blaze with a rapidity which would carry destruction through the whole expanse of the terraqueous globe, and change its present aspect into that of a new world:—at the same time, all the other laws of nature might still operate as they have hitherto done since the creation of the world.

I do not mean positively to assert, that this is the agent which the Almighty will certainly employ for accomplishing this terrible catastrophe (though I think it highly probable), since Infinite Power is possessed of numerous resources for accomplishing its objects, which lie beyond the sphere of our knowledge and comprehension. But I have brought forward this fact, to show with what infinite ease this event may be accomplished, when Almighty Power is interposed. By means of the knowledge we have acquired of the constitution of the atmosphere, and by the aid of chemical apparatus, we can perform experiments on a *small scale*, similar in kind, though infinitely inferior in degree, to the awful event under consideration. And, therefore, we can easily conceive that He who formed the expansive atmosphere which surrounds us, and who knows the native energy of its constituent principles, may, by a simple volition, make that invisible fluid, in a few moments, the cause of the destruction of the present constitution of our world, and, at the same time, the means of this subsequent renovation. For, as fire does not annihilate, but only changes the forms of matter, this globe on which we now tread, and which bears the marks of ruin and destruction in several parts of its structure, may come forth from the flames of a general conflagration, purified from all its physical evils, adorned with new beauties and sublimities, and rendered a fit habitation for pure intelligences, either of our own species or of another order. For though "the heavens," or the atmosphere, "shall be dissolved, and the elements melt with fervent heat;" "yet," says the apostle Peter, "we, according to his promise, look for new heavens and a new earth,

wherein dwelleth righteousness." Whether, after being thus renovated, it shall be allotted as the residence of the redeemed inhabitants of our world, is beyond our province at present to determine. But if not, it will, in all probability, be allotted as the abode of other rational beings, who may be transported from other regions, to contemplate a new province of the Divine empire, or who may be immediately created for the purpose of taking possession of this renovated world. For we have reason to believe that the energies of Creating Power will be continually exerted, in replenishing the boundless universe, throughout all the ages of infinite duration; and that no substances, or worlds, which God has created, will ever be suffered to fall into annihilation—at least, that the original atoms of matter will never be destroyed, whatever new forms they may assume, and however varied the combinations into which they may enter.

The above are only a few examples out of many which were intended to be specified, of the illustrations which the system of nature affords of the doctrines and facts of Revelation, but the narrow limits of this volume prevent further enlargement.

It was also intended to follow up the preceding discussions with particular illustrations of the following topics:—The views which science affords of the *incessant energies of Creating Power*—the changes and revolutions which appear to have happened, and which are still going on in the distant regions of the universe, *as tending to amplify our views of the grand and multifarious objects over which Divine Providence presides*—the *connection of science with a future state*—the aids which the discoveries of science afford, in enabling us to form a conception of the scenes of future felicity—of the employments of the heavenly inhabitants, and of their perpetual advances in knowledge and happiness, and in their views of the perfections of Deity\*—the *moral relations of intelligent beings to their Creator, and to each other*; and the *physical grounds or reasons of those moral laws which the Deity has promulgated, for regulating the conduct, and for promoting the harmony and order of intelligent agents*—illustrations of the allusions of the Sacred writers to the system of the material world—the *simultaneous progress of science and religion*, considered as an evidence of the connection of the one with the other—the *moral effects of the study of science in connection with religion*—replies to objections and insinuations which have been thrown out against the idea of combining the discoveries of Science with the discoveries of Revelation, &c. But, as illustrations of these, and various other topics connected with them, would occupy several hundreds of pages, they must, in the meantime, be postponed.‡

\* Several of these subjects, along with many others, are fully illustrated in the author's volume, entitled, "The Philosophy of a Future State."

† These and a variety of kindred topics are illustrated in considerable length in my work entitled "The Philosophy of Religion: or, an illustration of the Moral Laws of the Universe, on the principles of reason and Divine Revelation"—in which an original and popular train of thought is prosecuted, and the different topics are enlivened with illustrative facts derived from the scenery of nature and the moral history of mankind.

‡ Several of the topics alluded to in this paragraph will be found more or less illustrated in the author's volumes, entitled "Celestial Scenery"—and "The Sidereal Heavens"—in which "the incessant energies of Creating Power"—the changes and revolutions which have happened and are still going forward in the distant regions of the universe—the doctrine of a plurality of worlds—and many other kindred topics, are particularly elucidated.

## CHAPTER V.

### BENEFICIAL EFFECTS WHICH MIGHT RESULT TO CHRISTIAN SOCIETY, FROM CONNECTING THE DISCOVERIES OF SCIENCE WITH THE OBJECTS OF RELIGION.

I—*The VARIETY OF TOPICS which would be introduced into Christian Instructions, by connecting them with the manifestations of Deity in the system of Nature, would have a TENDENCY TO ALLURE THE ATTENTION OF THE YOUNG TO RELIGIOUS SUBJECTS, and to afford Mental Entertainment, and Moral Instruction, to intelligent minds of every description.*

NOVELTY and VARIETY appear to be essentially requisite in order to rouse the attention, not only of the more ignorant, but even of the more intelligent class of mankind, and to excite them to make progress in the path of intellectual and moral improvement. The principle of *curiosity*, which appears at a very early period of life, and which variegated scenery and novel objects tend to stimulate and to gratify—so far from being checked and decried, in a religious point of view, as some have been disposed to do, ought to be encouraged and cultivated in the minds both of the old and of the young. As it is a principle which God himself has implanted in our natures, for wise and important purposes, it requires only to be chastened, and directed in a proper channel, in order to become one of the most powerful auxiliaries in the cause of religion, and of intellectual improvement. To gratify this principle, and to increase its activity, the Creator has adorned our globe with a combination of beauties and sublimities, strewed in endless variety over all its different regions. The hills and dales, the mountains and plains; the seas, the lakes, the rivers; the islands of every form and size which diversify the surface of the ocean; the bays, the gulfs, and peninsulas; the forests, the groves, the deep dells, and towering cliffs; the infinite variety of trees, plants, flowers, and vegetable productions of every hue, so profusely scattered over the face of nature; the diversified productions of the mineral kingdom; the variegated coloring spread over the face of nature; together with the many thousands of different species of animated beings which traverse the air, the waters, and the earth—afford so many stimuli to rouse this principle into exercise, and to direct the mind to the contemplation of the Creator. And, as the earth displays an endless diversity of objects, so the heavens, in so far as they have been explored, exhibit a scenery both grand and variegated. There is not a planet in the Solar System but differs from another, in its magnitude, in its distance from the central luminary about which it revolves, in the velocity of its motion, in the extent of the circle it describes around the sun, in the period of time in which its revolution is completed, in its rotation round its own axis, in the number of moons with which it is attended, in the inclination of its axis to the plane of its orbit, and the diversity of seasons which results from this circumstance; in the density of its atmosphere, and the various appear-

ances which diversify its surface. And, if we were favored with a nearer view of these majestic orbs, we should, doubtless, behold a similar variety in every part of their internal arrangements.—The surface of the moon presents a variegated prospect of mountains and vales, but so very different in their form, position, and arrangement, from what obtains on the surface of our globe, that it would exhibit a scenery altogether new and uncommon to an inhabitant of this world, were he placed on the surface of that planet. Every comet too is distinguished from another, by its magnitude, the extent of its atmosphere, the length of its blazing tail, the rapidity of its motion, and the figure of the curve it describes around the sun. With regard to the fixed stars, which are distributed, of every size, and in every direction, through the immensity of space, our senses as well as the declaration of an inspired writer, convince us, that in point of brilliancy, color, motion, and magnitude, “one star differeth from another star in glory.” Almost every *Ne-bula* of the 3000 which have been discovered, differs from another in its figure, extent, brightness, and general appearance; and the motions of double and treble stars, as to the periods of their revolutions, are as diversified as those of the planets—some of them revolving around their centers in 30 or 40 years, others requiring 400, and even 1600 years to finish their circuits—some of them diffusing a bluish light, others a red, and others a brilliant white.

And as the system of nature in all its parts, presents a boundless variety of scenery, to arouse the attention, and to gratify the desire for novelty, so the revelation of God, contained in the Sacred Records, displays a diversified combination of the most sublime and interesting subjects and events. Were we to form an opinion of the compass of Divine Revelation, from the range of subjects to which the minds of some professing Christians are confined, it might all be comprehended within the limits of five or six chapters of the New Testament; and all the rest might be thrown aside, as a dead weight upon the Christian system. But here, as in all the other displays of the Almighty, Divine Perfection and Providence are exhibited in the most diversified aspects. Here we have recorded a history of the creation and arrangement of our globe—of the formation of the first human pair—of their primeval innocence, temptation, and fall—of the arts which were cultivated in the first ages of the world—of the increase of human wickedness—of the building of the ark—of the drowning of the world by a universal deluge—of the burning of Sodom by fire from the clouds—of the origin of languages—of the dividing of the Red sea—of the journeying of the tribes of Israel through the deserts of Arabia—of their conquest of the promised land, and their wars with the nations of Canaan—of the corporeal translation of

Elijah from earth to heaven—of the manifestation of the Son of God in human flesh, the benevolent miracles he performed, and the triumphs he obtained over all the powers of hell and earth.—We are here presented with the most interesting and affective narratives, elegies, dramatic poems, and triumphal songs,—with views of society in the earliest ages of the world, when the lives of men were prolonged to nearly a thousand years,—with splendid miracles performed in the land of Egypt, in the wilderness of Horeb, and in the “field of Zoan,” when “the sun and moon stood still in their habitation;” when the waters of the great deep were divided, and mountains shook and trembled “at the presence of Jehovah;”—with the glorious marching of a whole nation through the Arabian deserts, under the guidance of a miraculous pillar of cloud and fire,—with the visits of celestial messengers, and the visible symbols of “a present Deity;”—with prophetic delineations of the present and future condition of the race of Adam, with descriptions of the Power, Wisdom, Love, and Majesty of the Almighty, and of his operations in Heaven and Earth,—with the results and bearings of the Economy of Redemption,—with Divine Songs, Odes, and Hymns, composed by angels and inspired men,—with maxims of moral wisdom, examples of sublime eloquence, of strength of reasoning, and of manly boldness of reproof—with Proverbs, Parables, Allegories, Exhortations, Promises, Threatenings, and Consolatory Addresses.—In short, we have here detailed, in the greatest variety—History, Antiquities, Voyages, Travels, Philosophy, Geography, Natural and Moral Science, Biography, Arts, Epic Poetry, Epistles, Memoirs, Delineations of Nature, Sketches of Human Character, Moral Precepts, Prophecies, Miracles, Narrations, Wonderful Providences, Marvelous Deliverances, the Phenomena of the Air, the Waters, and the Earth; the Past, the Present, and the Future Scenes of the World—all blended together in one harmonious system, without artificial order, but with a majesty and grandeur, corresponding to the style of all the other Works of God, and all calculated to gratify the principle of curiosity—to convey “reproof, correction, and instruction in righteousness,” and “to make the man of God perfect, and thoroughly furnished to every good work.”

And as the scenes of Nature, and the scenes of Revelation, are thus wonderfully diversified, in order to excite the attention of intelligent beings, and to gratify the desire for variety, so we have every reason to believe, that the scenes, objects, and dispensations which will be displayed in the heavenly world, will be incomparably more grand and diversified. When we consider the immensity of God’s Universal Kingdom, and the numerous systems, and worlds, and beings comprehended within its vast circumference, and that the energies of Creating Power may be forever exerted in raising new worlds into existence—we may rest assured, that the desire of variety and of novelty in holy intelligences, will be completely gratified throughout an endless succession of existence; and that the most luxuriant imagination, in its boldest excursions, can never go beyond the reality of those scenes of diversified grandeur which the Heaven of heavens will display.

Now, since the Book of Nature and the Book of Revelation, since all the manifestations of the Creator in heaven and earth, are characterized by their sublime and diversified aspect—we would ask, why should we not be imitators of God, in displaying the diversified grandeur of his King-

dom of Providence and of Grace before the minds of those whom we profess to instruct? Why should we confine our views to a few points in the Christian system, to a few stones in the fabric of the Divine operations, when “a wide and unbounded prospect lies before us?” Why should we not rather attempt to rouse the moral and intellectual energies of mankind, from the pulpit, from the press, in the school-room, and in the family circle, by exhibiting the boundless variety of aspect which the Revelations of Heaven present, and the holy tendencies of devout contemplation on the Works and the Ways of God—that they may learn, with intelligence, to “meditate on *all* the works of the Lord, and to talk of *all* his doings?”—By enlarging and diversifying the topics of religious discussion, according to the views now stated, we have it in our power to spread out an intellectual feast to allure and to gratify every variety of taste,—the young and the old, the learned and the unlearned, yea, even the careless and the ignorant, the skeptical and the dissipated, might frequently be allured by the selection of a judicious variety of striking and impressive subjects and descriptions, to partake of those mental enjoyments which might ultimately issue in the happiest results. The man of an inquisitive turn of mind, who now throws aside everything that has the appearance of religion, on account of its dullness, might have his curiosity gratified amidst such a variety as that to which I allude; and, from perceiving the bearing of every discussion on the great realities of religion and a future state, might be led to more serious inquiries after the path that leads to immortality. In a word, to associate and to amalgamate, as it were, the arts and sciences, and every department of useful knowledge with Divine subjects, is to consecrate them to their original and legitimate ends, and to present religion to the eyes of men in its most sublime, and comprehensive, and attractive form, corresponding to what appears to be the design of the Creator, in all the manifestations he has given of himself, in the System of Nature, in the operations of Providence, and in the Economy of Redemption.

## II.—By connecting Science with Religion, Christians would be enabled to take an EXTENSIVE SURVEY OF THE KINGDOM OF GOD.

How very narrow and limited are the views of most professors of religion respecting the universal Kingdom of Jehovah, and the range of his operations! The views of some individuals are confined chiefly within the limits of their own parish, or at farthest, extend only to the blue mountains that skirt their horizon, and form the boundary of their sight. Within this narrow circle, all their ideas of God, of religion, and of the relations of intelligent beings to each other, are chiefly confined: There are others, who form an extensive class of our population, whose ideas are confined nearly to the county in which they reside, and to the adjacent districts: and there are few, comparatively, whose views extend beyond the confines of the kingdom to which they belong—though the whole island in which they reside is less than the two-thousandth part of the globe we inhabit. Of the vast extent of this earthly ball, of its figure and motions, of its continents, seas, islands, and oceans; of its volcanoes and ranges of mountains, of its numerous and diversified climates and landscapes; of the various nations and tribes of mankind that people its surface, and of the moral government of God respecting them,—

they are almost as completely ignorant as the untutored Greenlander, or the roving savage.—With regard to the objects which lie beyond the boundary of our world, they have no precise and definite conceptions. When the moon is “walking in brightness” through the heavens, they take the advantage of her light to prosecute their journeys; and, when the sky is overcast with clouds, and they are anxious to travel a few miles to their destined homes, they will lift up their eyes to the heavens to see if any of the stars are twinkling through the gloom, that their footsteps may be directed by their glimmering rays. Beyond this they seldom soar. What may be the nature of the vast assemblage of shining points which adorn the canopy of their habitation, and the ends they are destined to accomplish in the plan of the Creator’s operations, they consider as no part of their province to inquire.

“Their minds, fair Science never taught to stray  
Far as the Solar Worlds, or Milky Way.”

How very different in point of variety, of grandeur, and of extent, are the views of the man who connects all the different departments of knowledge, and the discoveries of science, with his prospects of God’s Universal Dominions and Government! With his mental eye he can traverse the different regions of the earth, and penetrate into the most distant and retired recesses where human beings have their residence. He can contemplate and adore the conduct of Divine Sovereignty, in leaving so many nations to grope amidst the darkness of Heathen idolatry,—he can trace the beams of the Sun of Righteousness, as they gradually arise to illumine the benighted tribes of men,—he can direct his prayers, with intelligence and fervor, in behalf of particular kindreds and people,—he can devise, with judgment and discrimination, schemes for carrying the “salvation of God” into effect,—he can realize, in some measure, to his mental sight, the glorious and happy scenes which will be displayed in the future ages of time, when “the kingdoms of this world shall become the kingdoms of our Lord, and of his Christ,” and when the “everlasting gospel” shall be published, and its blessings distributed among all who dwell upon the face of the earth. He can bound from this earth to the planetary worlds, and survey far more spacious globes, peopled with a higher order of intelligences, arranged and superintended by the same Almighty Sovereign, who “doth according to his will among the inhabitants of the earth.” He can wing his way beyond the visible region of the sky, until he find himself surrounded on every hand with suns and systems of worlds, rising to view, in boundless perspective, throughout the tracts of immensity—diversified with scenes of magnificence, and with beings of every order—all under the government and the wise direction of Him who “rules among the armies of heaven,” and who “preserveth them all,” and whom the “host of heaven worship” and adore. He can soar beyond them all to the Throne of God, where angels and archangels, cherubim and seraphim, celebrate the praises of their Sovereign Lord, and stand ready to announce his will by their rapid flight to the most distant provinces of his empire. He can descend from that lofty eminence to this terrestrial world, allotted for his temporary abode, and survey another unbounded province of the empire of God, in those living worlds which lie hid from the unassisted sight, and which the microscope alone can descry. He can here perceive the same Hand and Intelligence

which direct the rolling worlds above, and marshal all the angelic tribes—organizing, arranging, and governing the countless myriads of animated existence which people the surface of a muddy pool. He can speed his course from one of these departments of Jehovah’s kingdom to another, until, astonished and overwhelmed with the order, the grandeur, and extent of the wondrous scene, he is constrained to exclaim,—“Great and marvellous are thy works, Lord God Almighty!” “Thine understanding is infinite!” “The limits of thy dominions are past finding out!”

By taking such extensive surveys of the empire of Jehovah, we are enabled to perceive the spirit and references of those sublime passages in the sacred writings which proclaim the majesty of God and the glory of his kingdom. Such passages are diffusely scattered through the inspired volume, and have evidently an extent of reference far beyond what is generally conceived by the great mass of the Christian world. The following may suffice as a specimen:—

“Thine, O Lord! is the greatness and the glory, and the majesty; for all in heaven and earth is thine! Thine is the kingdom, O Lord! Thou art exalted above all, thou reignest over all, and in thine hand is power and might.—Behold, the heaven and the heaven of heavens is the Lord’s; the earth also, with all that therein is.—Ascribe ye greatness to our God; for there is none like unto the God of Israel, who riseth upon the heavens in his strength, and in his excellency in the sky. Thou, even thou art Lord alone; thou hast made heaven, the heaven of heavens, with all that therein is; the earth and all things that are therein; the sea and all that is therein; and thou preservest them all, and the host of heaven worshippeth thee.—He divided the sea by his power; by his spirit he hath garnished the heavens: Lo! these are only parts of his ways; but how little a portion is heard of him, and the thunder of his power who can understand! The Lord hath prepared his throne in the heavens, and his kingdom ruleth over all.—O Lord our God! how excellent is thy name in all the earth! who hast set thy glory above the heavens. When I consider thy heavens, the work of thy fingers, the moon and the stars which thou hast ordained; what is man that thou art mindful of him!—His kingdom is an everlasting kingdom; honor and majesty are before him; all the inhabitants of the earth are reputed as nothing in his sight, and he doth according to his will in the armies of heaven and among the inhabitants of the earth.—He measures the waters in the hollow of his hand; he meteth out heaven with a span, and comprehendeth the dust of the earth in a measure.—He sitteth upon the circle of the earth, and the inhabitants thereof are as grasshoppers.—I have made the earth and created man upon it; I, even my hands, have stretched out the heavens, and all their host have I commanded.—The Most High dwelleth not in temples made with hands; for the heaven is his throne and the earth is his footstool. With God is awful majesty.—Great things doth He which we cannot comprehend; yea, the Lord sitteth King forever.—Praise ye the Lord in the heavens; praise him in the heights; praise him, all his angels; praise ye him, all his hosts. Praise him, sun and moon; praise him, all ye stars of light; praise him, ye heaven of heavens. Praise him, ye kings of the earth, and all people, princes, and judges of the earth; both young men and maidens; old men and children—let them praise the name of the Lord; for his name alone is excellent, his glory is above the earth and heaven.”

These sublime descriptions of the supremacy of God and of the grandeur of his kingdom, must convince every reflecting mind of the inconceivable magnificence and extent of that dominion "which ruleth over all." It is quite evident that we can never enter, with intelligence, into the full import and the grand reference of such exalted language employed by inspired writers, unless we take into view all the discoveries which science has made, both in the earth and in the heavens, respecting the variety and extent of the dominions of the Creator. If the "kingdom of the Most High" were as limited in its range as most Christians seem to conceive, such descriptions might be considered as mere hyperbole of bombast, or extravagant declamation, which far exceed the bounds of "truth and soberness." But we are certain that the conceptions and the language of mortals can never go beyond the reality of what actually exists within the boundless precincts of Jehovah's empire; for "who can utter the mighty acts of the Lord?" or "who can show forth *all* his praise?" The language and descriptions to which we have now adverted seem to have had a prospective reference to later and more enlightened times, when more extensive prospects of God's dominions would be opened up by the exertions of the human intellect. And were we to search all the records of literature, in ancient or modern times, we should find no descriptions nor language of such a dignified nature as to express the views and feelings of an enlightened Christian philosopher, when he contemplates the sublimity and extent of Divine operations—except those which are to be found in the inspired volume—the strength, and majesty, and comprehension of which no human language can ever exceed.

Again, by familiarizing our minds to such extended prospects of God's universal kingdom, we shall be qualified and disposed to comply with the injunctions of Scripture, which represent it as an imperious duty to *communicate to the minds of others such elevated conceptions*. This duty is enjoined in numerous passages of sacred Scripture, particularly in the book of Psalms: "Declare his glory among the heathen, and his wonders among all people.—I will extol thee, my God, O King.—One generation shall praise thy works to another, and shall declare thy mighty acts.—I will speak of the glorious honor of thy majesty, and of thy wondrous works.—And men shall speak of the might of thy terrible acts, and shall declare thy greatness. All thy works shall praise thee, O Lord; and thy saints shall bless thee. *They shall speak of the glory of thy kingdom, and talk of thy power; to make known to the sons of men thy mighty acts, and the glorious majesty of thy kingdom.*"\* When we look around us in the world, and in the visible church, and mark the conceptions and the conversation of the members of religious societies, we need scarcely say how little this ennobling duty is attended to by the mass of those who bear the Christian name. We hear abundance of idle chat about the fashions and the politics of the day; about balls, horse-races, court etiquette, theatrical amusements, contested elections, the squabbles of corporations, sectarian contentions, and ecclesiastical feuds. We listen to slanderous conversation, and hear abundance of mean, and base, and uncharitable insinuations against our neighbors; which indicate the operation of malice, hatred, envy, and other malignant

dispositions. We spend whole hours in boisterous disputations about metaphysical subtleties in religion, and questions "which gender saith rather than godly edifying;" but "to speak of the glory of God's kingdom, and to talk of his 'power,'" with the view of "making known to the sons of men his mighty works," is a duty which remains yet to be learned by the majority of those who profess the religion of Jesus. Even sincere Christians, while "taking sweet counsel together,"—when conversing about the love of Christ, and "the deep things of God," and when endeavoring to cheer each other's spirits with the comforts of religion—seldom or never advert to the visible works of God, and the displays of his power and beneficence, as manifested in creation, from which they might derive additional comfort and support to their faith, hope, and joy, and more expansive views of the perfections and character of their Father and their friend. And how can they be supposed to be qualified to enter into the spirit of such exercises, and to proclaim to others "the glorious majesty of God's kingdom," unless such subjects be illustrated in *minute detail*, and proclaimed with becoming energy, both from the pulpit and from the press? These powerful engines, when conducted with judgment and discrimination, are capable of producing on the mass of mankind a tone of thinking and an enlargement of conception on such subjects which no other means can easily effect; and it is to be hoped that more precise and luminous details, and more vigor and animation will soon be displayed in this respect than in the ages that are past.

There is a certain principle of *selfishness* which pervades the minds of many professed religionists, which leads them to conclude that, if they can but secure their own *personal salvation*, they need give themselves no trouble about the glory and extent of the kingdom of the Most High. "What need we care," say they, "about nations in the far-distant parts of the world, and about the planets and the stars? our business is to attend to the spiritual interests of our souls." Such persons seem neither to understand in what salvation really consists, and what is conducive to their spiritual interests, nor to appreciate those tempers and habits which will qualify them for the enjoyment of eternal life. It forms but a very slender evidence of their possessing any spark of Christianity at all, if they wish to rest satisfied with the most vague and groveling conceptions, and if they do not ardently aspire after a more enlarged view of the attributes of God, and the glory of his empire, and of whatever may tend to expand their conceptions of the "inheritance of the saints in light." We have often been astonished at the opinions of some of those who move in a higher sphere of intelligence, who seem to consider it as a matter of *pure indifference* whether or not Christians should attain to the highest conception in their power of the God whom they worship, and of his boundless dominions; because they conceive that such views are not essentially connected with salvation! But we would ask such persons how they came to know that such views are not connected with salvation! Though they may not have been essential to the salvation of men in the dark ages that are past, or to obscure tribes of people at present, who have no access to the proper sources of information, yet, since God, in the course of his providence, which guides all human inventions and discoveries, has disclosed to us a far more expansive view of the "glory of his kingdom," than former ages could obtain, for the purpose of illustrating the revelations of his word,

\* Psalm cxlv. and xvi. 3, 4.

who will dare to assert that the man who has access, by his studious efforts, to contemplate this wondrous scene, and to display its grandeur to others, and yet willfully shuts his eyes on the divine glory therein displayed, does not thereby hazard the Divine displeasure? In this point of view, the following passage deserves a serious consideration: "because they regard not the works of the Lord, nor the operations of his hands, he shall destroy them, and not build them up." We have no hesitation in admitting that persons may have obtained salvation who never saw more of the sacred writings than what is contained in the gospel of Mark, or in one of Paul's epistles; but what should we say of the man who had access to all the revelations of heaven we now possess, and yet confined his attention solely to a chapter or two in the New Testament, and would not deign to look into any other part of the inspired volume? We should not hesitate at once to pronounce that such a person was grossly deficient in his duty, and devoid of that reverence and submission which are due to the oracles of God.—And if it be admitted that the person who has access to the Bible, and who refuses to peruse its important contents, is guilty of a criminal neglect, we do not see how the man who has free access to the other volume of God's revelation, and views it as a matter of mere indifference whether he look into it or not, can be deemed in this respect entirely innocent. If it be understood that we shall be judged according to the light and privileges we enjoy, and the use we make of them in our improvement in the knowledge of God—we would deem it a hazardous position for any one to support, "That inattention to the visible glories of the kingdom of God, and to the 'declaration of his wonders among the people,' is a matter either of indifference or of trivial importance."

For, let it be considered further, that on the extent of our views respecting the universal kingdom of God, depends our conceptions of the majesty and glory of the Creator himself. We become acquainted with the nature of God only in so far as he has manifested himself to us by external operations,\* and in so far as we form just conceptions of these operations. If we conceive his empire as included within the bounds of eighty or ninety thousand miles, our conceptions of the Sovereign of that empire will be circumscribed within nearly the same limits. The mind of every reasonable man must indeed admit the abstract proposition, "That the Divine Being is infinite, and consequently fills all space with his presence."—But this infinity, in our view, is nothing more than a *vague conception of empty space, extending a little way beyond the sphere of his visible operations.* The mind must have some material, visible, or tangible objects to rest upon, and to guide it in its excursions when it would attempt to form the most definite and comprehensive conceptions of an infinite, eternal, and invisible existence. For, however much we may talk about purely *spiritual ideas*, it is quite evident, from the nature of things, and from the very constitution of man, that we can have no ideas at all without the intervention of *sensible objects.* And therefore, if we would wish to form the most sublime conceptions of God himself, we must endeavor, in the first place, to take the most extensive views which science and revelation exhibit of his vast dominions. We must endeavor to form some adequate idea of the

wide extent of the globe on which we dwell, its diversified scenery, and the numerous tribes of human beings and other animated existences, visible and invisible, which people its different provinces. We must explore the vast regions of the planetary system, and compare the bulk of the earth, large as it is, with some of those more magnificent globes which would contain within their circumference a thousand worlds as large as ours. We must next wing our way, in imagination, over a space which a cannon ball, flying five hundred miles every hour, would not traverse in ten hundred thousand years, until we arrive at the nearest fixed stars, and find ourselves in the center of thousands of systems and worlds, arranged at immeasurable distances from one another. We must pass from one nebula, or cluster of systems, to another; continuing our excursions as far as the eye or the telescope can direct our view; and, when the aid of artificial instruments begins to fail, our imagination must still take its flight far beyond the boundaries of mortal vision, and add system to system, and nebula to nebula, through the boundless regions of space, until we arrive at the grand center of the universe, the Throne of God, around which all worlds and beings revolve, where "thousands of thousands" of bright intelligences "minister to Him, and ten thousand times ten thousand stand before Him."—We must consider all this magnificent assemblage of objects, not merely as so many masses of inert matter, or as a grand rare-show, to dazzle the eyes of a few hundreds of human spectators,—but as destined for purposes worthy of the plans and the intelligence of Him who is "the only wise God,"—as peopled with numerous orders of intelligent beings, whose physical and moral economy is superintended and directed by Him who, at the same time, rules amidst the tumults of human revolutions, and governs the living myriads which people a drop of water.

In this way, then, do we come to acquire the most extensive views of the amplitude and glory of the kingdom of the Most High; and it is only by the same process of thought that we can ever attain the most exalted conceptions of the attributes of its Almighty Sovereign. For our views of the Sovereign of the universe must always correspond with our views of the extent and magnificence of those dominions which sprung from his Creating Hand, and over which he every moment presides. His essence must forever remain imperceptible to finite minds; for He is "the King Eternal, Immortal, and Invisible, dwelling in that Light which no man can approach unto, whom no man hath seen, or can see." From his nature, as a spiritual uncompounded substance, and from his immensity, as filling infinite space with his presence, it appears impossible, in the very nature of things, that the glory of his perfections can be displayed in any other way than through the medium of the visible operations of his hands, or in the dispensations of his providence toward particular worlds or classes of intelligences. And if, in the future world, the souls of good men shall enjoy a more glorious display than at present of the attributes of Deity, it will be owing chiefly to their being placed in more favorable circumstances than they now are for contemplating this display; to their faculties being more invigorated; and every physical and moral impediment to their exercise being completely removed; so as to enable them to perceive more clearly than they now do the unbounded displays he has given of his infinite Power, Wisdom, and Benevolence. And, if

\* Here I include the manifestation of Deity as exhibited both in Divine Revelation and in the system of Nature.



we expect to be introduced to this state of enlarged vision when we pass from the scenes of mortality, it cannot be a matter of mere indifference, even now, whether or not our minds be prepared for such exalted employments, by endeavoring to form the most ample conceptions of the attributes of God which can be obtained through the medium of his Word, and by a contemplation of the variety and magnificence of his Works.

In the prospect of that world where we hope to spend an interminable existence, it must also be interesting to ascertain, whether or not the dominions of the universal Sovereign present such an extent of empire, and such a variety of objects, that new scenes of wonder and glory may be expected to be displayed in continual succession, for the contemplation and entertainment of holy beings, while eternal ages are rolling on. And, on this point, the discoveries of science confirm and illustrate the notices of heavenly glory and felicity recorded in the inspired Volume, and lead us to rest with full assurance on the prophetic declaration, that "eye hath not seen, nor ear heard, nor hath it entered into the heart of man to conceive, the things which God hath prepared for them that love him."

III.—By connecting the Discoveries of Science with Religion, the minds of Christians would be enabled to take a more minute and comprehensive survey of the OPERATIONS OF PROVIDENCE.

Providence is that superintendence and care which God exercises over all creatures and events, in order to accomplish the eternal purposes of his will. In *Creation*, God brought the universe out of nothing, and arranged all its provinces and inhabitants into due order. By his *Providence*, he supports and governs all the movements of the material system, and the sensitive and rational beings with which it is peopled. It is evident, that, in proportion as our views of the Creator's Dominions are extended, our views of his Providence will, to a certain extent, be proportionably enlarged. For, wherever worlds and beings exist, there will God be found preserving, superintending, and governing the movements of all creatures and events. It is chiefly, however, in the world in which we reside, that the diversified dispensations of Providence can be distinctly traced. Now, an acquaintance with the prominent parts of the different branches of knowledge to which I have already adverted, would enable us to take a particular and comprehensive view, not only of the ways of God to man, but also of his arrangements in reference to all subordinate creatures and events.

From the Inspired History of the Old Testament, we can trace the prominent lines of the dispensations of God toward man, particularly in regard to the Israelites and the surrounding nations—from the Creation to a period about 400 years before the coming of Christ. But in order to perceive the further progress and bearings of these lines until the commencement of the New Testament economy, we must have recourse to the most authentic records of profane history. From the era of the birth of Christ to near the close of the first century, we can acquire, from the Evangelists, and the History of the Apostles, a particular account of the life of Christ, of the events which preceded and accompanied the finishing of the work of redemption, and of the progress of the Gospel through Judea, and the adjacent countries. But, after this period, we have no inspired guide to direct us in tracing the Divine

dispensations toward the various nations of the earth; and therefore we must have recourse to the annals, memoirs, chronicles, and other records of the history of nations, down to the period in which we live; otherwise we could never contemplate the continued series of events in the Divine economy toward the inhabitants of our world. Unless men of learning and of observation had recorded the prominent facts which have occurred in the history of nations, for 1700 years past, we must have remained almost as ignorant of the dispensations of God toward our race, during that period, as the inhabitants of the planet Saturn; and unless we study the events thus recorded in the writings of the historian, and contemplate their various aspects and bearings in the light of Divine Revelation, we must still remain ignorant of the grand movements and tendencies of Divine Providence. This single circumstance shows, in the clearest light, that it is the intention of God, that we should learn the operations of his Providence from the researches of Science and of History, as well as from the records of Revelation; and that the Scriptures, though they contain every *supernatural* discovery requisite to our happiness, are not of themselves sufficient to present us with a connected view of the prominent dispensations of Heaven, from the Creation to the period in which we live.

From the science of *Geography*, we acquire a knowledge of the extent of the surface of the earth—the various tribes of human inhabitants with which it is peopled—of the physical aspect of the different climates they inhabit—of their arts, manners, customs, laws, religion, vices, wars, and political economy; and, consequently, we can, in these and similar respects, trace some of the aspects of Divine Providence toward them in relation to their present and future condition. From the same source, we learn the number of human beings which the Governor of the world has under his direction at one time, which is nearly a thousand millions, or about four hundred times the number of the inhabitants of Scotland. From the data afforded by this science, we may also form an estimate of the number of disembodied spirits that have passed from this world since the creation, and are now under the superintendence of the Almighty in the invisible state, which cannot be much less than 145,000 millions; and, on similar grounds, we may also learn the number of rational beings that are coming forward into existence, and passing into the eternal world every day, which is at least 68,000, and consequently nearly 50 during each passing minute,—every individual of which the Supreme Disposer of events superintends at his entrance into life; and, at his departure from it, directs to his respective and eternal state of destination. Hence it follows, that, could we take a view of the whole system of animation on our globe with the eye of Omniscience, or even with the penetrating glance of an angelic being, we should behold *every hour*, thousands of human and other animated beings incessantly emerging into existence, and thousands, at the same time, departing into an unseen world, under a vast diversity of circumstances; and this succession and exit of human beings will incessantly go forward from age to age, until all the desigus of Providence in relation to our world be fully accomplished. All which circumstances, and many others of a similar kind, must be taken into account, in order to our forming a comprehensive conception of the numerous bearings, and the incessant agency of a Superintending Providence.

From *Natural History*, we learn the immense number and variety of the subordinate tribes of animated beings which inhabit the different regions of earth, air, and sea—their economy and instincts—their modes of existence, and the manner in which the Creator provides for their various necessities. From an acquaintance with the *History of the Arts and Mechanical Inventions*, we learn the gradual manner in which God directs the movements of the human mind, in making those improvements and discoveries which have a bearing upon the accomplishment of his eternal plans of mercy, and which tend to enlarge our views of the amplitude and the glories of his kingdom.—From *Natural Philosophy and Chemistry*, we learn the secondary causes or subordinate laws by which the Almighty supports and directs the natural constitution of the world—the wonderful manner in which our lives are every moment supported—and the agencies by which fire, air, light, heat, and fertility are distributed through the globe, for promoting the comfort and happiness “of everything that lives.”—From *Anatomy and Physiology*, we learn how “fearfully and wonderfully we are made and preserved”—that our health and comfort depend upon the regular action of a thousand organical parts and functions over which we have no control—and that our very existence every moment is dependent on the superintendence of a Superior Power, “in whose hand our breath is, and whose are all our ways.”

By an occasional study, then, of the subjects to which we have now alluded, we might gradually expand our conceptions of the range and operations of Divine Providence. Every geographical exploration of a new region of the globe—every scientific improvement and discovery—every useful invention—every eruption of a volcano—every shock of an earthquake—every hurricane, and storm, and tempest—every battle of the warrior—every revolution among the nations—and every detail in the newspapers we daily read, would lead us to form some conceptions of the providential purposes of Him who is the Supreme Disposer of all events.—Even the arrangements of Divine Wisdom, with regard to the economy of the lower animals, ought not to be overlooked in such a survey. When we consider the immense number and variety of animated beings—that there are 600 species of quadrupeds, every species containing, perhaps, many millions of individuals; 4000 species of birds; 3000 species of fishes; 700 species of reptiles; and 44,000 different kinds of insects, beside many thousands of species altogether invisible to the unassisted sight—when we consider that the structure and organization of all these different species are different from each other, and exactly adapted to their various situations and modes of existence, and that their multifarious wants in regard to food and habitation, are all provided for, and amply supplied by Him, who, at the same time, arranges and governs the affairs of ten thousand worlds—we must be lost in astonishment at the greatness of the Intelligence which formed them, and at the exuberance of that bounty which spreads so full a table for so immense an assemblage of living beings! And were we transported to other worlds, we should, doubtless, behold still more ample displays of Divine Beneficence.

We are here presented with a striking commentary on such passages of the Sacred Volume as these: “The eyes of all look unto thee, O Lord! and thou givest them their meat in due season. Thou openest thy hand liberally, and satisfiest the

desire of every living thing. The earth is full of thy riches, O Lord! so is the great and wide sea, wherein are things creeping innumerable, both great and small beasts. These all wait upon thee, and thou givest them their meat in due season. That which thou givest them they gather: Thou openest thine hand, they are filled with good.”—“O Lord, thou preservest man and beast! How excellent is thy loving-kindness! Therefore the children of men shall put their trust under the shadow of thy wings. They shall be abundantly satisfied with the fatness of thy house”\* (of the table thou hast spread in thy world for all thine offspring), “and thou shalt make them drink of the river of thy pleasures.” One excellent practical effect which might flow from such contemplations would be to inspire us with feelings of humanity toward the inferior order of animals, and to prevent us from wantonly and unnecessarily torturing, or depriving them of existence. For, since the Creator and Preserver of all has so curiously organized their bodies, and fitted them for the different regions in which they reside, and so carefully provided for all their wants, it must be His will that they should enjoy happiness according to the extent of their capacities; and, therefore, they ought to be considered as necessary parts of our sublunary system.—Another practical lesson we may derive from such surveys, is, to place an unshaken dependence upon God for our temporal subsistence, while we, at the same time, exert all our faculties in the line of active duty. “Blessed is the man who trusteth in him; for there is no want to them that fear him. The young lions may suffer hunger, but they that fear the Lord shall not want any good thing.”—He who decks the lily of the vale, and spreads out a plentiful table to the fowls of heaven, to the beasts of the forest, to the creeping insect, and even to the microscopic animalcule, will never fail to supply the necessary wants of those who “do His will, and hearken to the voice of His commandments.” And if at any time we be found destitute of daily food, and pining away in penury and squalid disease, we have too much reason to conclude, that in one way or another, either our deviation from the path of rectitude, or our distrust of Divine Providence, or our want of prudence and economy, has procured for us these things.

I have said, that it is chiefly in the world in which we dwell that the dispensations of Providence can be distinctly traced. But we must, nevertheless, admit, that the care and superintendence of God are as minutely exercised in the distant regions of the universe, as in our terrestrial sphere; though we are not permitted, at present, to inspect the particular details of His procedure in reference to other orders of intelligences. We are not, however, altogether ignorant of some prominent features of the physical and moral economy of other worlds, in consequence of the discoveries of modern astronomical science.

With respect to their *physical* economy, we behold a striking variety in the Divine arrangements. We perceive one planetary world surrounded by

\* This and several other similar passages, may be considered as more especially applicable to the bounty of Providence which God has provided for all his creatures. The practice of *spiritualizing* such passages, as it is termed, has a tendency to caricature Scripture, and to twist it from its precise and sublime references, to accord with the vague fancies of injudicious minds. The literal meaning of Scripture is always the most appropriate, emphatic, and sublime, but it may, in some cases, be used by way of accommodation, in illustrating divine subjects when it is applied with judgment and discrimination.

two splendid and magnificent rings, one of them 204,000, and the other 184,000 miles in diameter, stretching across its celestial canopy from one end of the heavens to another—moving with majestic grandeur around its inhabitants every ten hours, and diffusing a light equal to several thousands of moons like ours—which may be considered as a visible and permanent emblem of the Majesty and Glory of their Creator. We perceive, connected with the same globe, seven moons all larger than ours, of different magnitudes, and placed at different distances, and revolving in different periods of time around that spacious world. The diversified aspects of these rings, as viewed from the different regions of the planet at different times, and the variety of appearances produced by the alternate rising, setting, culmination, and frequent eclipses, and other aspects of the moons, must be presented to the inhabitants a very grand, and diversified, and magnificent scene of Divine operation.\* On the other hand, we behold another planetary globe destitute both of rings and moons, but which has the starry heavens presented to view nearly in the same aspect in which we behold them. We perceive a third globe much larger than them both, capable of containing 200 times the number of the inhabitants of our world—accompanied in its course with four moons to diffuse light in the absence of the sun, and to diversify the aspect of its sky. In some of these worlds, the succession of day and night is accomplished within the space of ten hours; in others, this revolution is not completed until after the lapse of twenty-four hours, or of as many days. In some, the days and nights are nearly equal on every part of their surface, and they have little variety of seasons; in others, the variety in the length of the days and the vicissitudes of the seasons, are nearly the same as those we experience in our terrestrial world. Around some, there appears a dense atmosphere, while others are environed with atmospheres more rare and transparent. Some move in the vicinity of the sun, and enjoy an abundant efflux of light and heat, while others are removed to the distance of eighteen hundred millions of miles from that central luminary. Some finish the revolution of their year in a few months; while others require twelve, thirty, or even eighty of our years to complete their annual round. Some appear adorned with majestic mountain scenery, and others seem to have great changes occasionally taking place in their atmospheres, or on their surfaces. There are four planetary bodies lately discovered, which, there is every reason to believe, once formed the component parts of a larger globe; but, by some mighty catastrophe in the dispensations of Heaven, it appears to have been burst asunder into the fragments we now behold. If the general proposition illustrated in Section II of the preceding chapter be admitted, such a fact would seem to indicate, that a moral revolution has taken place among the intelligent beings who had originally been placed in those regions; and that their fate was involved in the dreadful shock which burst asunder the globe they inhabited, just as the fate of the Antediluvians was involved in the shock by which the solid crust of our globe was disrupted, at the period of the universal deluge.

These are some outlines in the economy of Providence which we can trace with regard to the arrangements of other worlds; but beyond such general aspects we are not permitted to penetrate, so long as we sojourn in tabernacles of clay. But

even such general views afford some scope to the contemplative mind, for forming enlarged conceptions of the Grandeur and Diversity of the Dispensations of God, in the worlds which roll in the distant regions of space.

With regard to their *moral economy*—we may rest assured, that the prominent outlines of it are materially the same as of that economy which relates to the inhabitants of our world. The fundamental principles of the moral laws given to men, and which it is the great object of Revelation to support and illustrate, are, "Thou shalt love the Lord thy God with all thy heart and understanding," and, "Thou shalt love thy neighbor as thyself." On these two commandments hang all the Law and the Prophets.—Now we must at once admit from the Nature of the Divine Being, and from the relation in which rational beings stand to Him, and to one another,—that the Creator has enacted these laws, as the great governing principles by which the actions of all intelligences in heaven, as well as upon earth, are to be directed. For the governor of the world can never be supposed to issue a law to any order of rational creatures, which would permit them to *hate* their Creator, or to hate those whom he has formed after his own image. Such a supposition would be inconsistent with the eternal rules of rectitude, and with the perfections of Deity; and the fact supposed (if it could exist), would introduce confusion and misery throughout the whole intelligent universe. And, therefore, we must necessarily admit, that the laws to which I now advert, are binding upon all the rational inhabitants which exist throughout Jehovah's dominions; and that it is by these that the moral order of all the Principalities and Powers of Heaven is preserved and directed. In those worlds where there is no change in the succession of their inhabitants—or, in other words, where there is no death, or where they are not produced by any process analogous to generation, but have a fixed and permanent residence—there will be no need for moral precepts corresponding to the fifth and seventh commandments of our moral law; and, in those worlds where property is common, and the bounties of the Creator are equally enjoyed by all, there will be no necessity for a law corresponding to the eighth commandment; but the general principles on which these laws are founded, will be applicable to all the other circumstances and relations which actually exist: so that the *principle*, and *spirit*, and *essence* of our religion, must be common to all the holy inhabitants of the universe. And, therefore, it will follow, that every intelligent being that is animated and directed by such principles and affections, will be qualified for holding delightful intercourse with all holy beings throughout the universe of God, in whatever province of the Creator's empire he may hereafter be placed; and, to qualify us for such harmonious and affectionate intercourses, is one great end of the Salvation exhibited in the Gospel. So that, although we cannot, in our present state, acquire a minute and comprehensive knowledge of the moral history of other worlds, of the special interpositions or manifestations of Deity in relation to them, or of the means by which they are carried forward in moral and intellectual improvement—yet we can trace the *general* principles or laws which form the basis of their moral and religious economy. For, as the laws of optics, and the principle of gravitation, pervade the whole material system, as far as the universe is visible to our unassisted vision—so the principle of supreme love to God, and sincere affection to

\* See the Frontispiece, Fig. 7.

fellow-intelligences, must pervade the *intellectual* universe wherever it extends; and, if any intelligent agents beside men have violated these laws, they must experience pain, and misery, and disorder, analogous to those which are felt by the inhabitants of our apostate world.

Thus I have endeavored to show, that the combination of Science with Religion, would tend to expand our views of Divine Providence—in the various arrangements of God, in relation to the human race, and to the subordinate tribes of sensitive beings—and in reference to some of the prominent features of his administration in distant worlds. And, therefore, though the Christian ought never to overlook the ways of Providence in relation to himself, and to his spiritual and domestic concerns, yet it would argue a selfishness and a sottishness, altogether inconsistent with the noble and expansive spirit of Christianity, to overlook all the other parts of the Theater of Divine Dispensations, when a very slight degree of labor and research might be instrumental in unfolding them to his view

IV.—*The connection of Science with Religion would have a tendency to induce upon Christians A SPIRIT OF LIBERALITY, OF CANDOR, AND OF ACCURACY IN JUDGING OF THE OPINIONS AND ACTIONS OF MEN, AND OF THE DIVINE PROCEDURE AND OPERATIONS.*

Who is the most Candid and Liberal Being in the universe? God.—And why is God to be considered as the most Liberal Intelligence that exists? Because He embraces a minute, a full, and comprehensive view of all the circumstances, connections, relations, habits, motives, temptations, modes of thinking, educational biases, physical affections, and other causes, that may influence the sentiments or the conduct of any of his creatures.—Who, among created intelligences may be viewed as endowed with these qualities in the next degree? The loftiest seraph that God has created, who has winged his way to numerous worlds; and taken the most extensive survey of the dispensations of the Almighty, and of all creatures and events.—Who, among the sons of men, is the most illiberal and inaccurate in judging of opinions, of persons, and of things? The man who has lived all his days within the smoke of his father's chimney, or within the confines of his native village—who has never looked beyond the range of his own religious party—whose thoughts have always run in one narrow track—whose reading has been confined to two or three musty volumes, which have lain for ages on the same smoky shelf—who cares for nothing either in the heavens or the earth, but in so far as it ministers to his convenience, his avarice, or his sensual enjoyment—who will admit no sentiment to be true, but what he may have heard broached by his parson—and whose conversation seldom rises beyond mere gossiping chit-chat, and the slanderous remarks which are circulated among his neighbors. Such characters are entirely unqualified for forming a correct judgment, either of the sentiments and the actions of men, or of the works and the ways of God; for they are completely destitute of the requisite *data* whereon to form a rational decision in relation to either of these subjects.

It may be admitted as a kind of axiom, in our estimate of human character, that, in proportion to the ignorance, and the narrow range of view, which characterize any individual, in a similar proportion will be his want of candor, and his

unfitness for passing a sound judgment on any subject that is laid before him—and that the man who has taken excursions through the widest range of thought, accompanied with a corresponding improvement of his moral powers, will always be the most liberal and candid in his decisions on the moral and intellectual qualities of others. To these maxims, few exceptions will generally be found.—In forming an enlightened judgment in regard to any action or object, it is essentially requisite, that we contemplate it in all its different features and aspects, and in all its minute circumstances, bearings, and relations.—We would not hesitate for a moment to determine who is best qualified to give an accurate description of a city,—he who has only viewed its spires from a distance, while in rapid motion in his chariot—or he who has minutely surveyed all its streets, lanes, squares, public edifices, and surrounding scenery, in every variety of aspect; or, who appears most likely to form the most accurate and enlightened judgment in relation to any particular kingdom,—he who has just skirted along a few miles in one of its coasts, or he who has traversed its length and breadth in all directions, and mingled with every class of its inhabitants. On the same principle it must be admitted, that he who has viewed religion in all its aspects and bearings, who has taken the most extensive survey of the manifestations of God, and of the habits and relations of men, is the best qualified to pronounce a candid and accurate decision on all the intellectual and moral cases that may come before him.

If the spirit of the above-stated sentiments be founded on reason and on fact, it will follow that, the more we resemble God in the amplitude of our intellectual views and benevolent affections, the more candid, and liberal, and accurate will our judgments be in reference to all the actions, objects, and relations we contemplate. On the other hand, the man who is confined to a narrow range of thought and prospect, is continually blundering in the estimates he forms, both in respect to physical facts, to general principles, and to moral actions. He forms a premature and uncharitable opinion on every slander and report against his neighbor. He condemns without hesitation, and throws an unmerited odium on whole bodies of men, because one or two of their number may have displayed weakness and folly. He hates and despises men and their opinions, because they belong not to his political or religious party. He pronounces his decisions on the motives of men with as much confidence as if he had surveyed their hearts with the eye of Omniscience. He cannot hear an objection against his favorite opinions with patience, nor an apology for any set of principles but his own. He is arrogant and dogmatical in his assertions, and will make no concessions to the superior wisdom of others. He sets himself, with violence, against every proposal for reformation in the church, because his forefathers never thought of it, and because such "innovations" do not suit his humor and preconceived opinions. He decides, in the most confident tone, on what God *can* and *cannot* do, as if he had taken the gauge of infinite perfection; and he frets at the Divine dispensations when they do not exactly quadrate with his own humors and selfish views.

With regard to the operations of the Most High he also forms the most foolish, and vague, and contradictory conceptions. Tell him of the vast dimensions of the planetary system, of the men and animals that live on the opposite side of the

globe, of the annual and diurnal motion of the earth—that this world and its inhabitants are moving through the regions of space many thousands of miles every hour—that one of the planets is so large that it would contain 1400 worlds as spacious as ours—that, another is flying through the tracts of immensity at the rate of a hundred thousand miles an hour—and that light is darted from the sun at a velocity of 192,000 miles in a moment of time,—he will stare at you with astonishment at such extravagant assertions, and will sooner believe the stories of giants 100 feet high, and of fairies that can enter in crowds through the keyhole of his door. Instead of frankly acknowledging that “he is ignorant of such subjects, and of the grounds of such conclusions—that those that have studied them with intelligence are best capable of judging—that, if true, they must fill us with admiration of the glory of God—but that, as he has hitherto had no opportunity of examining such matters, he must suspend his assent until he inquire into the reasons which can be given for such amazing deductions;” instead of such concessions, which are the dictates of modesty and of common sense, he will tell you at once, without hesitation, and without a blush at his presumptuous decisions, that “it is all extravagance, and folly, and idle romance, contrary to Scripture, and reason, and common sense;” and will not hesitate to brand you as a heretic, for endeavoring to break loose his intellectual trammels!—thus tacitly declaring that he is far better qualified to pronounce a decision on such topics than all the philosophers and divines, and all the brightest geniuses who have appeared in the world for ages past; though he will at the same time admit, that he never gave himself the trouble to examine into such matters!

His views of the providential dispensations of God are equally partial and distorted. If disease, or poverty, or misfortune, happen to his neighbor, especially if he had withdrawn from the religious party to which he belongs, it is considered as a penal judgment for his error and apostasy. If prosperous circumstances attended his family or his religious party, it is viewed as a sign of Divine approbation. He seldom views the hand of God, except in uncommon occurrences, and then, he imagines that a miracle is performed, and that the wheels of nature are stopped in order to accomplish the event. He seldom looks beyond the precincts of his own church or nation, to observe the movements of the Divine footsteps toward other tribes of his fallen race. He overlooks the traces of Divine operation which are every moment to be seen above and around him—and yet, in the midst of all such partial and contracted views, he will sometimes decide on the Wisdom and Rectitude of the Ways of God, with as much confidence as if he had entered into the secret councils of the Eternal, and surveyed the whole plan of his procedure.

Such are a few prominent outlines of the character of thousands, whose names are enrolled as members of the visible church—whose illiberality and self-conceit are owing to the contracted notions they have formed of God and of Religion. And, surely, it must appear desirable to every enlightened Christian, that every proper mean should be used to prevent rational immortal beings from remaining enchained in such mental thralldom.

On the other hand, the man who takes an enlightened view of all the works and dispensations of God, and of all the circumstances and relations of subordinate beings, necessarily acquires a

nobleness and liberality of mind, and an accuracy in judging of things human and divine, which no other person can possess. He does not hastily take up an evil report against his neighbor; for he considers how unfounded such reports often are, and how much they are owing to the insinuations of envy or of malice. And, when he can no longer doubt of an evil action being substantiated against any one, he does not triumph over him in the language of execration; for, he considers all the circumstances, relations, feelings, and temptations with which he may have been surrounded; he considers, that he himself is a frail sinful creature, and might possibly have fallen in a similar way, had he been placed in the same situation. He does not trumpet forth the praises of a man who has performed *one* brilliant benevolent deed, as if he were a character to be admired and eulogized—while the general course of his life is marked with vice, and an utter forgetfulness of God and Religion; nor does he fix a stigma of immorality upon the person who may have acted foolishly or sinfully in one or two instances, while the general tenor of his conduct has been marked by purity and rectitude: for, in both cases he considers, that it is not an *isolated action*, but *general habits* which determine the character of any individual. He esteems the Wise and the Good, and holds friendly intercourse with them, to whatever political or religious party they belong. He can bear, with affability and candor, to have his opinions contradicted, and can differ from his neighbor in many disputed points, while, at the same time, he values and esteems him. He will not brand a man as a Heretic or a Deist, because he takes a view of some dogmas in Theology in a different light from what he himself does; for he considers the difference of habits, studies, pursuits, and educational prejudices, which must have influenced his opinions; and makes due allowance for the range of thought to which he may have been accustomed. He is always disposed to attribute the actions of others to good motives, when he has no proof to the contrary. He uses no threats nor physical force to support his opinions, or to convince gainsayers; for he knows that no external coercion can illuminate the mind, and that the strength of arguments, and the force of truth, can alone produce conviction. He is convinced how ignorant he is, notwithstanding all his study, observations, and researches, and presses forward, as long as he lives, to higher degrees of knowledge and of moral improvement.

He is an active promoter of every scheme that tends to enlighten and meliorate mankind, and to extend the knowledge of salvation to the ends of the earth; for he considers that it is not by miracles, but by the subordinate agency of intelligent beings, that God will effectuate the illumination and the moral renovation of our apostate race. He views the special agency of God in all the movements of the Scientific, the Religious, and the Political world, and perceives Him accomplishing his purpose, in the inventions of human genius, and in the economy of the minutest insect, as well as in the earthquake, the storm, and the convulsions of nations; for he considers the smallest atom, and the Hosts of Heaven, as equally directed by Eternal Wisdom, and equally necessary in the universal chain of creatures and events. He displays a becoming modesty in speaking of the ways and the works of God. When he meets with any dark and afflictive dispensation in the course of Providence, he does not fret and repine, but is calm and resigned, conscious that he perceives only a small portion of

the chain of God's dispensations, and is, therefore, unable to form a just comparison of the connection of any one part with the whole. When he contemplates the depraved and wretched condition of the greater part of the world, at present, and for thousands of years past, notwithstanding the salvation which has been achieved for sinners of mankind, he is far from arraigning the Divine goodness and rectitude, in leaving so many nations "to walk in their own ways;" for he knows not what relation this dismal scene may bear, what influence it may have, or what important impressions it may produce, on worlds and beings with which we are at present unacquainted.

He is cautious in pronouncing decisively respecting the dispensations of God, in regard to the universe at large. He does not, for example, assert, with the utmost confidence, as some have done, "that there never was, and never will be, to all the ages of eternity, such a bright display of the Divine Glory as in the Cross of Christ." He admires and adores the Condescension and the Love of God, in the plan of Salvation which the Gospel exhibits, and feels an interest in it far beyond that of any other special manifestation of Deity; but he dares not set limits to the Divine Attributes and Operations. He considers himself at present, with regard to the grand system of the Universe, in a situation similar to that of a small insect on one of the stones of a magnificent edifice, which sees only a few hairbreadths around it, and is altogether incapable of surveying the symmetry, the order, and beauty of the structure, and of forming an adequate conception of the whole. He considers that he has never yet surveyed the millionth part of Jehovah's empire, and, therefore, cannot tell what the Eternal Sovereign has been pleased to exhibit in its numerous provinces; and, least of all, can he ever presume to give into the depths of interminable ages, and boldly declare what the Almighty will, or will not do, through eternity to come. He, therefore, views it as presumption, while he has no dictate of revelation for his warrant, to pronounce decisively, either on the one side or on the other, of such a deep and important question, which seems above the reach of the loftiest seraph to determine.\* In short, he endeavors to take a view of all the manifestations of Deity within his reach, from every source of information which lies before him, and as far as his limited faculties will permit. He does not call in question the discoveries of Science, because they bring to his ears most astonishing reports of the Wisdom and Omnipotence of Jehovah; and of the boundless extent of his Kingdom; but rejoices to learn, that the grandeur of his dominions is actually found to correspond with the lofty descriptions of Divine Majesty and Glory recorded in the Volume of Inspiration, and is thereby inspired with nobler hopes of the glory and felicity of that heavenly world where he expects to spend an endless existence.

If, then, such be some of the features in the character of the enlightened Christian; if liberality and candor, and accurate investigation, mark the judgments he pronounces on the sentiments and the actions of men, and on the works and the ways of God; and if such views and feelings ought to be considered as more congenial to the noble and benevolent spirit of our religion, than the narrow and distorted notions of a contracted mind,—it must be an object much to be desired, that the mass of the Christian world be led into such trains of thought, as might imbue their

minds with a larger proportion of this spirit. And, if diversified and occasional discussions on the topics to which we have adverted would have a tendency to produce this desirable effect, it is obvious, that such branches of knowledge as are calculated to enlarge the capacity of the mind, and to throw a light over the revelations and the works of God, should no longer be overlooked in the range of our religious contemplations.

V.—*The extensive range of thought which the diversified objects in Nature present, would have a tendency to inspire us with a spirit of piety and profound humility.*

It is owing, in many instances, to want of attention to the impressive displays of Wisdom and Omnipotence in the material world, that our pious feelings and devotional exercises are so cold and languid. We stalk about on the surface of the earth, and pass from one day to another, without reflecting on the grand and complicated machinery around us, which is carrying us along through the regions of space, and from one portion of duration to another, as if the mighty energies of the Eternal Mind, exerted in our behalf, were unworthy of our acknowledgment or regard. How few, for example, reflect, when they open their eyes in the morning, and perceive the first beams of the rising sun, that, since they lay down to sleep, the Divine Power has been exerted in carrying them more than four thousand miles round to the eastward, in order that they might again be cheered with the morning light; and that, during the same period, they, along with the earth and its vast population, have been carried forward 476,000 miles from that portion of space which they occupied seven hours before! \* Or, if they have no idea of the motion of the earth, and attach no belief to such an opinion, how is it they do not reflect, that, after night has thrown its shades around them, the sun, and ten thousand other vast globes, must move several hundred millions of miles, before their eyes can again behold the light of day! Either the one or the other of these cases *must be the fact*; and, in either case, there is presented to our view, a display of the Omnipotence and the Superintendence of Him in whom we live and move, which demands our gratitude, our admiration, and praise. And can it ever be supposed, that such reflections, combined with all the other excitements to reverence and gratitude, will not tend to elevate our contemplations, and to raise our pious feelings to a higher pitch of devotion? Whether the Psalmist entertained any views of this kind, when he composed the ninety-second Psalm, we

\* When it is here said that we are carried "more than 4000 miles round to the eastward" during the hours of sleep—the author refers to the *diurnal* motion of the earth from west to east. The rate of this motion is different to the inhabitants of different latitudes. At the Equator the inhabitants are carried at the rate of 1038 miles an hour, and if 7 hours be allowed for nightly repose, they are carried round 7266 miles during sleep. Those who live in the 53d degree of latitude, as the inhabitants of places near London, move at the rate of 637 miles an hour; and, consequently, in the course of 7 hours, are carried round 4459 miles. The inhabitants of Greenland, in lat. 69°, during the same time, move only 250 miles; and, were there any inhabitants at the 88th degree of latitude, or within two degrees of the polar points, their motion, during 7 hours, would not exceed 252 miles.—When it is said we are carried forward during the same time, 476,000 miles, the reference is to the *annual* motion of the earth, which is at the rate of sixty-eight thousand miles every hour, and consequently 476,000 miles during the 7 hours supposed to be allotted to sleep.

\* See Appendix, Note XII.

cannot certainly determine; but I presume, the pious and contemplative mind, when awakening from the slumbers of the night, under such impressions, might sing the first part of that song of praise with peculiar emphasis and delight—"It is a good thing to give thanks to Jehovah, and to sing praise to thy name, O thou Most High! to show forth thy loving-kindness in the morning. For thou, Lord, hast made me glad through thy work" (or thy powerful energy),—"I will triumph in the works of thy hands. O Lord! HOW GREAT ARE THY WORKS! and thy thoughts" (or contrivances) "are very deep! A brutish man knoweth not, neither doth a fool understand this."

An extensive acquaintance with nature and science, combined with Christian principle, would also induce *profound humility*. The man who has made excursions through the most diversified regions of thought, is deeply sensible of the little progress he has attained, and of the vast and unbounded field of divine science which still remains to be explored. When he considers the immense variety of sublime subjects which the Volume of Inspiration exhibits, and of which he has obtained but a very faint and imperfect glimpse—the comprehensive extent, and the intricate windings of the operations of Providence, and the infinite number of beings over which it extends—the amplitude and magnificence of that glorious universe over which Jehovah presides, and how small a portion of it lies open to his minute inspection—he is humbled in the dust at the view of his own insignificance; he sees himself to be a very babe in knowledge; and, as it were, just emerging from the gloom of ignorance into the first dawns of light and intelligence. He feels the full force and spirit of the poet's sentiment—

"Much learning shows *how little* mortals know."

When he considers the comprehensive extent of the Divine law and its numerous bearings on every part of his conduct, and on all the diversified relations in which he stands to his God, and to his fellow-men; and when he reflects on his multiplied deviations from that eternal rule of rectitude, he is ashamed and confounded in the presence of the Holy One of Israel; and on a review of his former pride and self-conceit, is constrained to adopt the language of Agur and of Asaph—"Surely I am more brutish than any man, and have not the understanding of a man." "So foolish was I, and ignorant, I was as a beast before thee." He views the meanest and the most ignorant of his species, as but a very few degrees below him in the scale of intelligence, and sees no reason why he should glory over his fellows.

This sentiment might be illustrated from the example of some of the most eminent men in whose minds science and religion were combined. The Honorable Mr. BOYLE was the most unwaried and successful explorer of the works of God, in the age in which he lived, and all his philosophical pursuits were consecrated to the service of Religion. Among the excellent traits in his character, HUMILITY was the most conspicuous. "He had about him," says Bishop Burnet, "all that unaffected neglect of pomp in clothes, lodging, furniture, and equipage, which agreed with his grave and serious course of life," and was courteous and condescending to the meanest of his fellow-men. "He had," says the same author, "the profoundest veneration for the great God of heaven and earth that ever I observed in any person. The very *name* of God was never mention-

ed by him without a pause, and a visible stop in his discourse; and the tenor of his philosophical and theological writings is in complete unison with these traits of character.—Sir ISAAC NEWTON, too, whose genius seemed to know no limits but those of the visible universe, was distinguished by his *modesty, humility, and meekness* of temper. He had such a *humble* opinion of himself, that he had no relish of the applause which was so deservedly paid him. He would have let others run away with the glory of his inventions, if his friends and countrymen had not been more jealous of his honor than he was himself. He said a little before his death, "I do not know what I may appear to the world, but to myself I seem to have been only like a boy playing on the sea-shore, and diverting myself in now and then finding a pebble or a prettier shell than ordinary, while the great ocean of truth lay all undiscovered before me."

The same sentiment might have been illustrated from the lives of Bacon, Locke, Dr. Boerhaave, Hervey, Nieuwentyt, Ray, Derham, the Abbe Pluche, Bonnet, and other eminent characters, who devoted their stores of knowledge to the illustration of the Christian system. For an *extensive* knowledge of the operations of God has a *natural tendency* to produce humility and veneration; and wherever it is combined with pride and arrogance, either among philosophers or divines, it indicates a lamentable deficiency, if not a complete destitution, of Christian principle, and of all those tempers which form the bond of union among holy intelligences. After the attention of Job had been directed to the works of God, and when he had contemplated the inexplicable phenomena of the Divine agency in the material world, he was ashamed and confounded at his former presumption; and, in deep humility, exclaimed, "I have heard of thee by the hearing of the ear; but now mine eye seeth thee; wherefore I abhor myself, and repent in dust and ashes."—In accordance with what has been now stated, we find, that the most exalted intelligences, who, of course, possess the most extensive views of the works and providential arrangements of God, are represented as also the most humble in their deportment, and as displaying the most profound reverence in their incessant adorations. They "*fall down* before Him who sits upon the throne; and *cast their crowns before the throne*, saying, Thou art worthy, O Lord, to receive glory, and honor, and power; for thou hast created all things, and for thy pleasure they are and were created."—Their moral conduct evinces the same lowly temper of mind. They wait around the throne, in the attitude of motion, and wings outspread, ready to fly, on the first signal of their Sovereign's will; they "do his commandments, hearkening to the voice of his word," and do not disdain to perform important services, in our wretched world, to the meanest human being who is numbered among "the heirs of salvation." In like manner, were *we* induced with the grasp of intellect, the capacious minds, the extensive knowledge, and the moral powers which they possess, we would also display the same humble and reverential spirit, and feel ashamed of those emotions of vanity and pride, which dispose so many of the human family to look down with contempt on their fellow-mortals.

If the leading train of sentiment which pervades this volume be admitted, the following

**GENERAL CONCLUSIONS** may be deduced:—That, in conducting the religious instruction of the young, the works of God in the material world, and the most striking discoveries which have been made as to their magnitude, variety, and mechanism, should be frequently exhibited to their view, *in minute detail*; as illustrations of the attributes of the Deity, and of those descriptions of his nature and operations contained in the Volume of Inspiration;—that the books put into their hands should contain, among other subjects, popular and striking descriptions of the facts and appearances of

nature;—that seminaries should be established for the occasional instruction of young persons, from the age of fifteen to the age of twenty or thirty, or upward, in all those popular branches of natural and moral science which have a tendency to enlarge the capacity of their minds, and to expand their conceptions of the incessant agency of God;—and that the Ministers of Religion, in their public instructions, should frequently blend their discussions of divine topics with illustrations derived from the scenes of Creation and Providence.

## APPENDIX:

CONTAINING

### NOTES AND ILLUSTRATIONS.

**NOTE I, p. 22.**—*Illustration of the rate of Motion in the Heavenly Bodies, on the supposition that the earth is at rest.*

THE distance of the sun is about 95 millions of miles; consequently, the diameter of the circle he would describe around the earth would be 190 millions, and its circumference 597,142,857, which forms the extent of the circuit through which he would move in 24 hours, if the earth were at rest. This number, divided by 24, gives 24,880,952, the number of miles he would move in an hour; and this last number divided by 60, gives 414,682, the number of miles he would move in a minute. The nearest star is reckoned to be at least 20,000,000,000,000, or twenty bil-

lions of miles distant from the earth; consequently, its daily circuit round our globe would measure more than 125,000,000,000,000 miles. This sum, divided by 86,400, the number of seconds in a day, would give, 1,454,861,111, or somewhat more than one thousand four hundred millions of miles, for its rate of motion in a second of time,—a motion, which, were it actually existing, would, in all probability, shatter the universe to atoms.

The unlearned reader may, perhaps, acquire a more distinct idea of this explanation in the following figure:—

Fig. 32.

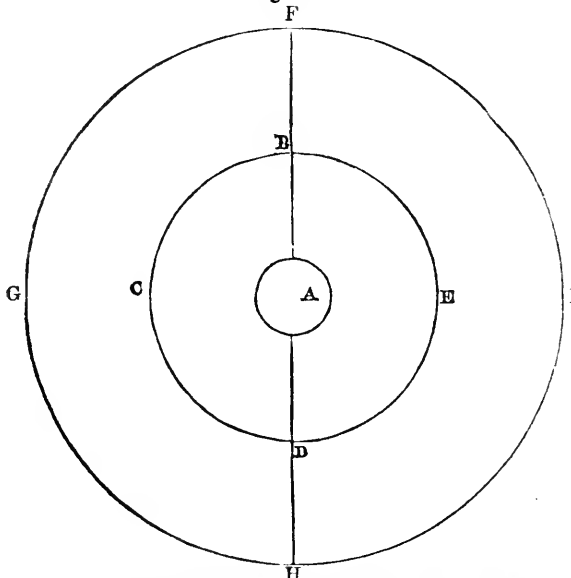

Let the small circle A, in the center, represent the Earth, and the circle B C D E the orbit of the Sun, on the supposition that he moves round the earth every 24 hours. The line A B will represent the distance of the Sun from the Earth, or

95 millions of miles; the line B D the diameter of the orbit he would describe; and the circle B C D E the circumference along which he would move every day, or 597 millions of miles, which is somewhat more than three times the diameter



If the line A F represent the distance of the nearest star, the circle F G H I will represent the circuit through which it would move every 24 hours, if the earth were at rest. It is obvious from the figure that since the stars are at a greater distance from the earth than the sun, the circle they would describe around the earth would be larger in proportion, and, consequently, their velocities would be proportionably more rapid; since they would move through their larger circles in the same time in which the sun moved through his narrower sphere. But, the supposition that the earth is the center of all the celestial motions, and that the different stars are daily moving around it with different velocities, and the slowest of these motions so inconceivably rapid, is so wild and extravagant, that it appears altogether inconsistent with the harmony of the universe, with the wisdom and intelligence of the Deity, and with all the other arrangements he has made in the system of nature.

NOTE II, pp. 31-94.—*Experimental Illustrations of the Pressure and Compressibility of the Atmosphere—The Diving-Bell, etc.*

The pressure of the atmosphere is most strikingly illustrated by means of the air-pump. But as few persons, comparatively, possess this instrument, the following experiments, which any person may perform at pleasure, are sufficiently convincing on this point. Take a common wine-glass, fill it with water; apply a piece of paper over the mouth of the glass; press the paper to the rim of the glass with the palm of the hand; turn the glass upside down; withdraw the hand from the paper; and the water will be supported by the pressure of the atmosphere. That it is the atmospheric pressure, and not the paper, which supports the water, is evident; for the paper, instead of being pressed down by the weight of the water, is pressed upward by the pressure of the atmosphere, and appears *concave*, or hollow in the middle. If the flame of a candle be applied to the paper, it may be held for an indefinite length of time, close to the paper, without setting fire to it. The same fact is proved by the following experiment:—Take a glass tube, of any length, and of a narrow bore; put one end of it in a basin of water; apply the mouth to the other end, and draw out the air by suction; the water will immediately rise toward the top of the tube; and if the finger or thumb be applied to the top of the tube, to prevent the admission of air, and the tube removed from the basin of water, the water in the tube will be supported by the pressure of the atmosphere on the lower end. Again:—Take a wine-glass, and burn a small bit of paper in it; and while the paper is burning, press the palm of the hand upon the mouth of the glass, and it will adhere to the hand with considerable force. In this case the pressure of the atmosphere will be *sensibly* felt; for it will sometimes require a considerable force to detach the glass from the hand.

The following experiment will also illustrate the pressure of the atmosphere. Take a tin vessel about 6 or 7 inches long and 3 in diameter, with its mouth about a quarter of an inch wide, as E F in Fig. 1.\* Pierce a number of small holes in its bottom, about the diameter of a common sewing needle. Plunge the vessel in water; and

when full, cork it up, so that no air can enter at top. While it remains corked no water will run out, being prevented by the atmospheric pressure, but the moment it is uncorked, the water will issue from the small holes in the bottom by the pressure of air from above.—The same experiment may be made by taking a tube, G H, Fig. 3,† 7 or 8 inches long, and about three-fourths of an inch diameter, having a small hole on each side, I K. When filled with water and corked no water will run out, but when the cork is removed the water will run out at I and K, illustrating the *lateral* pressure of the atmosphere.

The pressure of the atmosphere explains a variety of common phenomena. When we take a draught of water out of a basin or a running stream, we immerse our mouths in the water, and make a vacuum by drawing in the air; the pressure of the atmosphere upon the external surface of the water then forces it into the mouth. The same cause explains the process of a child sucking its mother's breasts—the action of a boy's sucker in lifting large stones—the rise of water in pumps—the effects produced by *cements*—the firm adhesion of snails and periwinkles to rocks and stones—the scarcity of water in the time of hard frosts—and the fact, that a cask will not run by the cock, unless a hole be opened in some other part of the cask.

The following experiment illustrates the *compressibility* of air, and at the same time the principle on which the *Diving-Bell* is constructed. Let A B, Fig. 1,‡ represent a large tumbler, nearly filled with water. Place a piece of cork on the surface of the water, and over the cork an ale-glass, C D, with its mouth downward: then push the glass perpendicularly down toward the bottom of the tumbler, and the cork will appear swimming a little above the bottom—indicating that there is no water above it in the ale-glass, but only *air*, which prevents the entrance of the water. If the water in the tumbler be supposed to represent the water of a river or of the sea, the ale-glass will represent the diving-bell in which a person may sit with safety in the depths of the sea without being immersed in the water, provided fresh air be supplied. A small quantity of water will be found to have entered the ale-glass, and the deeper it is plunged in any vessel the higher will the water rise within it; which proves the *compressibility* of the air within the glass.

The diving-bell has been much used of late in recovering valuable articles from the wrecks of ships that had sunk in deep water, and in blowing up such wrecks as are sunk near the mouths of rivers, and form impediments to navigation—by means of powder ignited by the electric spark. Major General Pasley has been employed for a considerable time past in blowing up the wreck of the Royal George man-of-war, which foundered at Spithead, near Portsmouth, in 1783. Many of the valuable articles belonging to this largest vessel of the British navy have thus been recovered. Five or six divers have been constantly employed, and no serious accidents have occurred. On the 20th June, 1842, 3065 cubic feet, or 61 loads of timber had been brought up from the wreck, beside 219 pigs of iron ballast, weighing 32 tons, 17 cwt. One of the best divers sent up 19 pigs or nearly 3 tons in one day. Most of the iron and brass cannons have thus been got up; and during the first 6 or 7 months of 1842 more than four thousand pounds

\* The figure referred to is in "Mental Illumination," p. 93 fig. 2.

† "Mental Illumination," p. 93, fig. 3.

‡ Ibid., p. 93, fig. 1.

of powder have been expended in these operations.—Dr. Payerne has lately invented a method for producing pure air, in such experiments, fit for the respiration of man, and for supporting flame without communication with the external air, which he has frequently successfully exhibited in London, in the diving-bell of the Polytechnic Institution; and on the 2d September, 1842, he put his invention to the test by descending at Spithead, along with Major Pasley, to the depth of 75 feet, when the water stood only 6 inches high at the bottom of the bell. The air they breathed in the bell was perfectly good; and the whole apparatus for purifying it was contained in a case not larger than a common portable writing-desk, which requires only the turning of a small winch occasionally, and no science on the part of the person in charge. When the diving-bell is once filled with compressed air, either by letting it escape from vessels previously filled with it, or by four men pumping for less than half-an-hour, no more pumping is necessary, as the air in the bell never requires to be changed. In the common mode of working the diving-bell, on the contrary, a powerful pump, manned by 6 or 8 men, would be required, as at Spithead, which must be kept constantly at work the whole time that the men are down in the diving-bell; and this incessant pumping is so laborious, that from 12 to 16 men, working in two reliefs, are necessary for the purpose of expelling the water.—Such inventions as that now stated may be applied to many practical and beneficial purposes, and perhaps to purposes more diversified and extensive than we can, in the meantime, anticipate.

NOTE III.—On the ideas of *Magnitude, Motion, and Duration*, as expressed by numbers. See p. 39, 41, etc.

In the pages referred to and in other parts of this work some very large numbers are expressed in *figures*. Some readers have insinuated, that it would have been better to express such numbers in *words*. The author, however, is of a different opinion; because, to some readers, not much acquainted with *Numeration*, a thousand *trillions* would convey nearly the same idea as a thousand *nonillions*, though the one number contains 58 places of figures, and the other only 22. It is chiefly the number of figures, or ciphers, in such large sums, that leads us to form a comparative estimate of their value or extent. Our ideas of magnitude and extension, conveyed by such numbers, must, of course, be very vague and undefined. If we have been accustomed to traveling we have a tolerably clear conception of a *hundred*, and even of a *thousand* miles; but we have no clear nor adequate conception of a *body*, or of a portion of space, ten hundred thousand, ten hundred millions, or ten hundred billions of miles in extent. The mind, however, may be assisted in its conceptions, and in its comparative estimate of different numbers, by fixing on some particular number as a standard. If, according to the common reckoning, we suppose, that 5828 years have elapsed since the commencement of time, the numbers of seconds, or moments, in this period, will amount to 183,913,782,212, or one hundred and eighty-three thousand, nine hundred and thirteen millions, seven hundred and eighty-two thousand, two hundred and twelve, which is less than a fifth part of a billion. If the distance of the nearest stars from the earth be at

least 20 billions of miles, then this distance may be otherwise expressed, by saying, that the number of miles which intervene between us and these bodies is more than a *hundred times greater* than the number of moments which have elapsed since the creation; and, by a similar comparison, it will be found, that the number of cubical miles, within the limits of the planetary system, is 1,02,000,000,000,000, or one hundred and thirty-two thousand billions of times greater than the number of moments in 5828 years.

It has been computed, that the earth, supposing it a solid globe, contains about 20,000,000,000,000,000,000,000,000,000, or thirty quintillions of grains of sand, supposing a hundred grains of sand to be equal in length to an inch, and, consequently, a million of such grains for every cubical inch. If we use this number as a standard for estimating the number of *cubical* miles contained within the space which intervenes between us and the nearest stars, we shall find that the number of *cubical miles* comprehended within this space is more than ten thousand millions of times greater than the number of the grains of sand contained in the globe on which we dwell.

Though the human mind can form no definite conceptions of such numbers and magnitudes, yet it may be useful occasionally to ruminat on such subjects; as it is the only, or at least the principal mode by which limited minds like ours can approximate to an idea of the *infinity* of the Creator. And if an *image* of infinity is presented to the mind in the spaces comprehended within the limits of our system, how overpowering the conception of innumerable systems, to which ours bears no more proportion than a drop of water to the mighty ocean! How ineffably glorious must be the attributes of that Incomprehensible Being who pervades every part of this vast universe, and who continually superintends all its minute and diversified movements!

NOTE IV, p. 58.—On the means by which it may probably be ascertained whether the Moon be a habitable world.

About the year 1818, the Author published in the Monthly Magazine, a few observations on the surface of the Moon, in which a few remarks were offered on this subject. The following is an extract from that communication:—

“If we be ever to obtain an ocular demonstration of the habitability of any of the celestial orbs, the Moon is the only one where we can expect to trace, by our telescopes, indications of the agency of sentient or intelligent beings; and I am pretty much convinced, that a long-continued series of observations on this planet, by a number of individuals in different places, might completely set at rest the question, ‘Whether the Moon be a habitable world.’ Were a vast number of persons, in different parts of the world, to devote themselves to a particular survey of the Moon—were different portions of her surface allotted to different individuals, as the object of their particular research—were every mountain, hill, cavern, cliff, and plain, accurately inspected—and every change and modification in the appearance of particular spots carefully marked and represented in a series of delineations, it might lead to some certain conclusions, both as to her physical constitution, and her ultimate destination. It can be demonstrated, that a telescope which magnifies 100 times, will show a spot on the Moon’s

surface, whose diameter is 1223 yards; and one which magnifies 1000 times, will, of course, enable us to perceive a portion of her surface, whose size is only 122 yards; and, consequently, an object, whether natural or artificial, of no greater extent than one of our large edifices (such as St. Paul's cathedral, London), may, by such an instrument, be easily distinguished. Now, if every minute point on the lunar surface were accurately marked by numerous observers, it might be ascertained whether any changes are taking place, either from physical causes, or from the operations of intelligent agents. If a large forest were cutting down—if a city were building in an open plain, or extending its former boundaries—if a barren waste were changing into a scene of vegetation—or, if an immense concourse of animated beings were occasionally assembled on a particular spot, or shifting from one place to another—such changes would be indicated by certain modifications of shade, color, or motion; and, consequently, would furnish a direct proof of the agency of intelligent beings analogous to man, and of the Moon being a habitable globe. For although we may never be able to distinguish the inhabitants of the Moon (if any exist), yet if we can trace those effects which can flow only from the operations of intelligent agents, it would form a complete demonstration of their existence, on the same ground on which a Navigator concludes an unknown island to be inhabited, when he perceives human habitations and cultivated fields.

“That changes occasionally happen on the lunar hemisphere, next the earth, appears from the observations of Herschel and Schroeter, particularly from those of the latter. In the Transactions of the Society of Natural Philosophy at Berlin, Schroeter relates, that, on the 30th December, 1791, at five o'clock, *p. m.*, with a seven feet reflector, magnifying 161 times, he perceived the commencement of a small crater on the south-west declivity of the volcanic mountain in the *Mare Crisium*, having a shadow of at least 2".5. On the 11th January, at twenty minutes past five, on looking at this place again, he could see neither the new crater, nor its shadow. Again, on the 4th January, 1792, he perceived, in the eastern crater of Helicon, a central mountain, of a clear gray color, 3" in diameter, of which, during many years' observations, he had perceived no trace. ‘This appearance,’ he adds, ‘is remarkable, as probably from the time of Hevelius, the western part of Helicon has been forming into its present shape, and Nature seems, in that district, to be particularly active.’—In making such minute observations as those to which I allude, it would be proper, along with an inspection of the Moon's luminous disc, to mark the appearances of different portions of her dark hemisphere, when it is partially enlightened by the reflected light from the earth, soon after the appearance of new moon. These researches would require a long-continued series of the most minute observations, by numerous observers in different regions of the globe, which could be effected only by exciting, among the bulk of mankind, a general attention to such investigations. But were this object accomplished, and were numerous observations made from the tops of mountains, and in the serene sky of southern climes, where the powers of the telescope are not counteracted by dense vapors, there can be little doubt that direct proofs would be obtained, that the Moon is a habitable world; or, at least, that the question in relation to this point would be completely set at rest.”

NOTE V.—Remarks on the pretended discovery of a Lunar Fortification.

The British public, not long ago, was amused by the announcement of a discovery said to have been made by Professor Fraunhofer of Munich. This gentleman was said to have discovered a fortification in the Moon, and to have distinguished several lines of roads, supposed to be the work of the lunar inhabitants. It is scarcely necessary to say, that such announcements are obviously premature. To perceive distinctly the shape of an object in the Moon, which resembles a fortification, it is requisite, that that object be of a much larger size than our terrestrial ramparts. Beside, although an object resembling one of our fortifications were perceived on the surface of the Moon, there would be no reason to conclude, that it served the same purpose as fortifications do among us. We are so much accustomed to war in our terrestrial system, and reflect so little on its diabolical nature, that we are apt to imagine that it must form a necessary employment even in other worlds. To be assured that a fortification existed in the Moon for the same purposes as with us, would indeed be dismal tidings from another world; for it would be a necessary conclusion, from such intelligence, that the inhabitants of that globe are actuated by the same principles of depravity, ambition, and revenge, which have infected the moral atmosphere of our sublunary world. With regard to the pretended discovery of the lunar roads, it may not be improper to remark, that such roads believed to be at least 400 feet broad, or ten times the breadth of ours, in order to be perceived as faint lines through a telescope which magnifies a thousand times; which is a higher power, I presume, than Fraunhofer can apply with distinctness to any of his telescopes. It is not at all likely that the lunar inhabitants are of such a gigantic size, or employ carriages of such an enormous bulk, as to require roads of such dimensions, since the whole surface of the Moon is only the thirteenth part of the area of our globe.

Schroeter conjectures the existence of a great city to the north of *Marius* (a spot in the Moon), and of an extensive canal toward *Hygena* (another spot), and he represents part of the spot named *Mare Imbrium*, to be as fertile as the Campania. See *Edin. Phil. Jour.*, No. 21, for July, 1824. Similar remarks to those now stated will apply to these conjectures of Schroeter. We are too apt to imagine, that the objects we perceive in the Moon must bear a certain resemblance to those with which we are acquainted on the Earth; whereas there is every reason to believe, from the variety we perceive in nature, that not one world resembles another, except in some of its more prominent and general arrangements. The moon bears a general resemblance to the Earth, in its being diversified with mountains and valleys; but the positions and arrangement of these objects in the Moon, and the scenery they exhibit, are materially different from what appears on the surface of the terraqueous globe.

NOTE VI, p. 89.—On a Plurality of Worlds.

The doctrine of a plurality of worlds is now admitted as highly probable, both by philosophers and by enlightened divines. But it has been admitted by many persons on grounds that are too general and vague, and, consequently, a full con-

viction of its truth is seldom produced in the mind. In different parts of the preceding volume, I have all along taken it for granted, because I consider it as susceptible of a *moral demonstration*.—The following heads of argument, were they fully illustrated, would go far to carry demonstration to the mind on this subject; namely, That there are numerous bodies in the universe of a bulk sufficient to contain myriads of intelligent beings, and to afford them enjoyment—that there appears, in the constitution of many of these bodies, a variety of arrangements evidently adapted to this end—that, in relation to the planets of our system, there are many circumstances which bear a striking resemblance to the constitution of our globe and its appendages. They have annual and diurnal motions, moons, atmospheres, mountains, and vales—that light, and heat, and color, appear to be distributed throughout the regions of immensity; and that these agents can have a relation only to the necessities and the happiness of organized intelligences—that every part of nature, so far as our observations on the surface of this globe extend, appears to exist solely for the sake of sentient beings—that this doctrine is more worthy of the Infinite Creator, and gives us a more glorious and magnificent idea of his nature, than to suppose his benevolent regards confined to the globe on which we dwell. When these and a variety of other arguments are considered, in connection with the *Wisdom* and other attributes of the Deity, they amount not only to a high degree of probability, but to something approaching to a moral demonstration. But to illustrate these arguments in minute detail, so as to make a convincing impression on the mind, would require a volume of a considerable size. The Author flatters himself he has some original thoughts on this subject, which may probably see the light, should the present work meet with public acceptance. There is no work in our language, which takes an extensive view of this subject, in connection with the attributes of Deity and the intimations contained in Divine Revelation. Fontenelle's "Plurality of Worlds," contains a number of ingenious reasonings; but he treats the subject in too light and flippant a manner, and without the least reference to a Supreme Intelligence. The celebrated Huygens, in his "*Cosmotheoros*," instead of attempting to prove the doctrine of a plurality of worlds, takes it for granted, and indulges chiefly in conjectures respecting the organical structure and faculties of their inhabitants.\*

That the Scriptures are silent on this head, has been assumed by some as a presumptive argument that this doctrine was without solid foundation. I have already endeavored to show that this assumption is unfounded† A plurality of worlds is more than once asserted in Scripture, and in numerous passages is evidently taken for granted. Celestial intelligences are represented as ascribing "glory, honor, wisdom, and power" to the King of heaven, "because he hath created all things, and because they perceive his works to be 'great and marvelous.'" But if all the great globes in the firmament were only so many frightful deserts, destitute of inhabitants, such a universe could never inspire superior intelligences with admiration of the *wisdom* of the Creator. For wisdom consists in proportioning *means* to

*ends*; but, in the case supposed, there would be no proportion between the means and the end. The means are indeed great and astonishing; but no end appears to justify such a display of creating energy.—The Psalmist, when he contemplated the heavens, was so affected with the idea of the immense population of the universe, that he seems to have been almost afraid lest he should be overlooked amidst the immensity of beings that are under the superintendence of God: "When I consider thy heavens—what is man that thou art mindful of him!" There would be no propriety nor emphasis in this exclamation, if the heavenly orbs were devoid of inhabitants; for, if no intelligent beings exist beside man, and a colony of angels, it would not appear wonderful that the Creator should exercise a particular care over the one-half of his intelligent offspring. But if we conceive the universe as composed of ten thousand times ten thousand worlds peopled with myriads of intellectual beings of various orders, the sentiments of admiration implied in the passage is extremely natural and emphatic, and conveys to us an impressive idea of the Intelligencer, the Beneficence, and the Condescension of the Founder and Governor of all worlds.

---

NOTE VII, p. 96.—*The Daguerreotype.*

The only deficiency in the pictures produced by means of the process discovered by Daguerre is, that they do not represent objects, in their *natural colors*, as exhibited by a convex lens in a dark chamber. It is not unlikely, however, that even this perfection may soon be attained. It has been just now (Sept. 1842) stated in the public journals, that Mr. Isenrig, a painter at Munich, has announced, that he has discovered a process by which, through the daguerreotype, he can depict all the objects in nature with the brilliancy of the colors, so as to bear comparison with the finished productions of the first artists.—If this announcement be correct, we may soon expect to have all the most interesting views of the scenery of nature and the operations of art depicted with an accuracy and a beauty, which have hitherto been unattainable by the most celebrated artists.

---

NOTE VIII, p. 99.—*Electro-Magnetic Machines.*

The possibility of moving small pieces of mechanism by the action of the electro-magnetic power has been known for some time past, but it seems never to have been practically applied on a large scale until in 1837 it was adapted to the propulsion of a boat on the river Neva, by Professor Jacobi of Petersburg. On the 25th September, 1838, a galley, 28 feet in length and 7½ in breadth, was provided with paddles similar to those of a steam vessel. The action was produced from 320 pair of plates, arranged along the sides of the galley, room being left for twelve persons. The vessel was made to proceed against the stream, and the speed attained in still water was three English miles per hour. The plan consisted in rapidly reversing the poles during the action.—Since the above period a machine has been contrived by Mr. R. Davidson of Aberdeen, in which a reiterated series of attractions are employed to produce the effect. The following is a brief account of Mr. Davidson's experiments, abridged from a letter of Professor Forbes of King's Col-

\* Since the first editions of this work were published, the author has fully illustrated the topics above stated, along with other kindred subjects, in his volumes entitled "Celestial Scenery," and "The Sideral Heavens," which are embellished with numerous engravings.

† See p. 89.

loge, Aberdeen. Mr. R. Davidson has made an arrangement by which, with only two electro-magnets, and less than one square foot of zinc surface (the negative metal being copper) a lathe is driven with such velocity, as to be capable of turning small articles. He has another arrangement by which, with the same small extent of galvanic power, a small carriage is driven, on which two persons are carried along a very coarse wooden floor of a room. He has likewise a third arrangement not yet completed, by which, from the imperfect experiments he has made, he expects to gain very considerably more force from the same extent of galvanic power than from either of the other two. The first two machines are exceedingly simple, without the least complexity, and therefore easily manageable, and not liable to derangement, and they take up very little room. As yet, the extent of power of which they are capable has not been at all ascertained, as the size of the battery employed is so trifling, and the magnets so few; but it seems probable that a very great power, in no degree inferior even to that of steam, but much more manageable, much less expensive, and occupying greatly less space—if the coals be taken into account—may be obtained. The Professor considers Mr. Davidson's inventions to be so interesting to railroad proprietors in particular, that it would be much for their interest to take up the subject and be at the expense of making the experiments necessary to bring this power into operation on a great scale.—The difference between Professor Jacobi's plan and Mr. Davidson's is this;—that Jacobi produces motion by changing the poles of the magnets, and Mr. Davidson, by cutting off the galvanic current at given points—the power of alternating as the rotation proceeds, from a neutralized magnet to a newly changed one. In both experiments it has been clearly demonstrated that the power of the magnet is increased, by increasing the diameter, and adding to the length of the helix. The power is also increased by increasing the size of the bars.

NOTE IX, p. 114.—*On the first Inventor of Printing.*

Mr. Ireland, in his "Picturesque Tour through Holland, Brabant, and part of France, in 1789," gives the following account of the Inventor of Printing, when describing the city of Haerlem. "Haerlem claims the invention of the art of Printing. It is attributed to Lawrence Koster, an alderman of this city, in 1440; whose house is yet standing in the market-place, opposite the church. Amusing himself one day in the neighboring wood, with cutting the bark of trees into letters that formed the initials of his name, he is said to have laid them on paper, and, falling asleep, when he awoke, observed, that, from the dew their form was impressed on the paper. This accident induced him to make further experiments; he next cut his letters in wood, and, dipping them in a glutinous liquid, impressed them on paper, which he found an improvement; and, soon after, substituting leaden and pewter letters, erected a press in his house; thus laying the foundation of this noble art, which has thence gradually arisen to its present excellence.—The art, it is said, was stolen from him by his servant, John Faustus, who conveyed it to Mentz, and, from the novelty of the discovery, soon acquired the title of Doctor and Conjuror. The original specimens are now shown at the Library in the Town Hall. The first is on

a leaf of parchment, and the second and third on paper, printed only on one side, and the corners left blank for capitals. At the top are wooden cuts, representing the Creation, and, as it is called, Lucifer's Fall."—pp. 109-111.

NOTE X, p. 117.—*On Telescopes; with a brief notice of a NEW REFLECTING TELESCOPE, constructed by the Author.*

It is doubtful to what particular individual we owe the invention of the telescope. Some have supposed that Roger Bacon and Baptista Porta invented this instrument. Borelli ascribes the invention to Zacharias Jansen, a native of Middleberg. Perhaps the account given in the article to which this note refers, and which is stated by a variety of authors, may be as probable as any other. It is certain the telescope was not in general use until the beginning of the 17th century, and that no discoveries in the heavens were made with it until the year 1609.

There are two kinds of telescopes, *Refracting* and *Reflecting*. In refracting telescopes, the rays of light pass through convex or concave glasses or lenses. The object-glass is always convex, and forms an image or picture of the object in an inverted position in its focus, which image is viewed by the eye-glass; and the magnifying power is in the proportion of the focal distance of the object-glass to that of the eye-glass. The focal distance of a convex glass may be ascertained by holding it in the rays of the sun, opposite to a piece of white paper, and measuring the distance between the glass and the white spot, or burning point, formed on the paper. An astronomical telescope for viewing celestial objects may be constructed with only two glasses. If an object-glass, 30 inches focal distance, be fixed in the end of a tube, and an eye-glass of one inch focus be placed at the other end, at the distance of 31 inches from the object-glass, a telescope will be formed which will magnify in the proportion of one to thirty, or 30 times; that is, objects seen through such a telescope will appear thirty times larger in diameter, or thirty times nearer than to the naked eye. By such an instrument, the inequalities on the Moon's surface, and some of the satellites of Jupiter, may be perceived; but when directed to land objects, they will appear inverted or turned upside down. In order to reverse the appearance of the object, two other eye-glasses are required;—or, if a *concave* eye-glass of a similar focus be placed at 29 inches from the object-glass, the object will appear in its natural position, and the magnifying power will be the same; but the field of view will be much smaller. Astronomical telescopes of this construction were formerly made of 120, and even of 200 feet in length, and were used without a tube; the object-glass being placed on the top of a long pole; but these are now entirely superseded by *achromatic* telescopes. In the achromatic telescope, the object-glass is compounded of two, and sometimes of three lenses, placed close to each other, one of which is a double concave of white flint glass, and the other a double convex of crown glass. By this means an image is formed without being blended with the prismatic colors; and it will, therefore, bear a large aperture, and a much greater magnifying power, than a common refractor. A good achromatic telescope four feet long will magnify objects as much as a common refractor 100 feet long.

In *Reflecting* telescopes the images of objects are formed by speculums or mirrors, instead of

lenses. They are of two kinds, the *Gregorian* and the *Newtonian*. The *Gregorian Reflector* consists of a tube in which a concave mirror, having a hole in its center, is placed. The rays of light from distant objects falling upon this mirror, form an image before it, in its center or focus. This image is intercepted by a smaller mirror, which reflects it back, through the hole in the large mirror to an eye-glass, through which the observer views the object. In the *Newtonian Reflector*, a plane mirror, placed at an angle of 45 degrees, is substituted in place of the small mirror, in the *Gregorian* construction, and the observer looks upon the object through the side of the tube. Sir David Brewster has suggested an interesting improvement in the construction of this instrument, which is described in the *Edin. Encyc.*, Art. *Optics*, p. 644.

**NEW REFLECTOR.**—Several years ago, the Author commenced a series of experiments on Reflecting Telescopes; and has lately constructed several on a new plan and principle. In this construction there is no small speculum, either plane, convex, or concave; there is no tube, except a short one of two or three inches in length, for holding the speculum. The observer sits with his back to the object, and views the image formed by the speculum through an eye-piece, which requires to be nicely directed and adjusted. Three or four instruments of this construction have been fitted up, with specula of 16, 28, 35, and 49 inches focal distance. One of them, having a speculum of eight inches focus, and two inches diameter, with a terrestrial eye-piece, magnifying about 25 times, forms an excellent parlor telescope for viewing land-objects, and exhibits them in a brilliant and novel aspect. When compared with a *Gregorian* of the same size and magnifying power, the quantity of light upon the object appears nearly doubled, and the image is *equally distinct*. It represents objects in their natural colors, without that dingy and yellowish tinge which appears when looking through a *Gregorian*. Another of these instruments, having a speculum of 28 inches focal distance, and an eye-piece producing a magnifying power of about 100 times, serves as an excellent astronomical telescope. By this instrument the belts and satellites of *Jupiter*, the ring of *Saturn*, and the mountains and cavities of the *Moon*, may be contemplated with great ease and distinctness. By placing the pedestal on the floor of the apartment, when the object is at a high elevation, we can view celestial phenomena with the same ease as if we were sitting at a writing-desk reading a book. With a magnifying power of about 40 times applied to this telescope, terrestrial objects appear extremely bright and well defined. A speculum of 49 inches focal distance, and 6½ inches diameter, has lately been fitted up on the same principle. With magnifying powers of from 100 to 130 times, it exhibits distinct and interesting views of the *Moon's* surface and of the ring of *Saturn*, and with a power of 56 times it affords a beautiful view of land objects. The specula used in some of these instruments are far from being good; being of a yellowish color, and scarcely half polished, and having large holes in the center; as they were originally intended for *Gregorian* reflectors; yet the brightness of vision approaches nearly to that of *Achromatic Telescopes*. The experiments which have been made on this subject demonstrate, that a tube is not necessary for a reflecting Telescope, when viewing either celestial or terrestrial objects; and, therefore, this construction of the instrument may be denominated, THE AERIAL REFLECTOR. The simplicity of the con-

struction, and the excellence of the performance of these instruments, have been much admired by several scientific gentlemen to whom they have been exhibited.\*

In the system of *Optics*, lately published in the *Edinburgh Encyclopedia* (one of the most luminous and comprehensive treatises which has yet appeared on this subject), the writer in his introduction to the account of Sir D. Brewster's improvement on the *Newtonian Telescope*, remarks:—"If we could dispense with the use of the small specula in telescopes of modern length, by inclining the great speculum, and using an oblique, and consequently a *distorted* reflection, as proposed first by *La Maire*, we should consider the *Newtonian Telescope* as perfect, and, on a large scale, or when the instrument exceeds 20 feet, it has undoubtedly this character, as nothing can be more simple than to magnify, by a single eye-glass, the image formed by a single speculum.—As the *front view* is quite *impracticable*, and, indeed, has *never been attempted* in instruments of a small size, it becomes of great practical consequence to remove as much as possible the evils which arise from the use of a small speculum," etc. The instruments noticed above have effectuated the desirable object alluded to by this respectable writer; and the principle of the construction is neither that of Sir W. Herschel's *front view*, nor does it coincide with that proposed by *La Maire*, which seems to have been a mere hint, which was never put into execution.

NOTE XI, p. 119.—On Steam Navigation, etc.

The application of steam, as a mechanical power, for impelling vessels and carriages, is one of the most brilliant and useful achievements of art which distinguish the present age, and is rapidly producing an important and interesting change both on inland and foreign intercourse. The fact that a vessel can be impelled by steam, against wind and tide, at the rate of twelve miles an hour, and a carriage on a railway with a velocity of thirty and upward, is sufficient to account for such a change. From the "Report of a Committee of Parliament," published in 1822, it appears, that the first application of steam to the impelling of vessels was made by an Englishman of the name of *HULL*, who, in 1736, obtained a patent for the invention of a steamboat, to be moved with a crank and paddles. But it was only in 1807 that the invention was fairly brought into practical use by Mr. *FULTON*, who had the advice and assistance of Mr. *BELL*, a Scottish engineer. In Britain, the first successful application of steam to vessels was made by Mr. *Bell*,† who built the *Comet*, of 25 tons and 4 horse power, to ply on the *Clyde*. Glasgow, which had the honor of introducing steam navigation on this side of the Atlantic, is still the seat of its greatest activity. In 1840, there were no less than 76 steamers of

\* The reader will find a more particular account of these instruments, accompanied with engravings, in the *Edinburgh Philosophical Journal* for July, 1826; the "*London Encyclopedia*," Art. *Telescope*, and in the "*London Mechanics Magazine*" for August, 1826. The Author has given a more particular description of these and various other astronomical instruments, in a work recently published.

† It is much to be regretted, and is certainly not congenial to the generous spirit of the age, that this gentleman, who was among the first inventors of steam navigation, and who did so much to promote its success in the neighborhood of Glasgow, never received any public reward for his services, but was allowed to finish his days in a condition approaching to poverty.

various sizes, comprising nearly 8000 tons, plying on the Clyde. Some of these, beside performing regular voyages to Inverary, Cambelton, Belfast, Dublin, Londonderry, Cork, Bristol, Liverpool, and other places, are also performing tours, during the summer months, to the Giant's Causeway, Staffa, Skye, and other parts of the Western Isles, and to Inverness by the Caledonian canal. Steam-vessels are also plying between Inverness and London, Perth and Dundee, Dumfries and Liverpool, Aberdeen and Leith, Dundee and London, Aberdeen and London, Leith and Dundee, Leith and London, Dover and Calais—from Liverpool to Lisbon, Cadiz, Gibraltar, Malaga, etc. In 1840, there were, throughout Great Britain and its colonies, no less than 630 steam-vessels, possessing an aggregate burden of 71,000 tons. The rivers on which these vessels chiefly ply are the Thames, the Severn, the Mersey, the Tyne, the Tay, the Forth, and the Clyde. From the Thames steamers proceed to Rotterdam, Boulogne, Havre, and many other ports on the continent. From Liverpool steam-vessels now regularly sail to the West Indies and America. These vessels are of an enormous size. The *Great Western*, the first steamer that sailed to America, is 1340 tons burden. The *Victoria* is a vessel of 500 horse power, and 27 feet longer than our largest man-of-war. The *British Queen* measures in entire length 275 feet. Her two engines are of 250 horse power each, and she is calculated to carry 1862 tons. Her outward voyage of 18 days requires a consumption of 549 tons of coal, and her homeward voyage of 12 days 360 tons. But larger vessels than even these are now in preparation. A regular communication is also now established by steam between Britain and India, by the Mediterranean, Egypt, and the Red sea.

Steam navigation on the continent is likewise making rapid progress. Steam-vessels are now to be found on the Garonne, Seine, Danube, Rhine, Rhone, lakes of Geneva and Constance, etc. It is likely that, in the course of a few years, such conveyances will be established on most of the friths and rivers both in Europe and America; and the period is no doubt hastening on when voyages will be made in such vehicles to the most distant regions of the world. A steam-vessel has for many years been sailing regularly, summer and winter, between New York and New Orleans, a distance of 2000 miles, in an open sea, exposed to great storms. On the coasts and rivers of North America, steam navigation is carried on to a much greater extent than in Great Britain or any other country. There are about 500 steam-vessels, most of them of very large size, plying on the Ohio, Mississippi, and other western waters. In this country, steam-vessels are fitted up with every accommodation and elegance which art can devise; so as to produce, if possible, as great a variety of enjoyment to passengers on sea as on land. Mr. Church, the American consul in France, in 1822, invented a paddle that revolves on the paddle-wheel by a very simple mechanism, which is found to save power. In the United States, a new mode of constructing cabins has been introduced, so as to place them beyond the reach of injury from explosions of the boiler. "The American steam-vessels are larger than ours, and are much more used for the conveyance of merchandise. The average proportion is about 1 horse power for every 4 tons of burden, computed in the usual way. The velocity is found to be nearly as the square of the power, so that an 80 horse power engine will produce only *twice* the velocity of one of 20 horse power. Something depends also on

the make and size of the vessel. Several years ago, the *Sovereign*, of 210 tons and 80 horse power, went 9 $\frac{3}{4}$  miles an hour in still water; and the *James Watt*, of 448 tons, and 100 horse power, 10 miles. For the paddle-boards, the rule is, that 3-10ths of a square foot of surface be immersed in the water for each horse power. Mr. Gladstone affirms, that so much power is wasted in displacing the water by the stroke of the board, that the velocity of the slip is only about one-half of that of the outer surface of the paddle-wheel. There are two sources of apprehension in steam-vessels—fire and the bursting of the boiler. With regard to the latter, when the boiler is of low pressure, it is satisfactorily established that not the smallest danger exists. And in the best constructed vessels, the danger from fire is completely obviated, by separating the furnace from the sides of the vessel by five inches of water."

An interesting Report was published some years ago of a series of experiments, made with a *new steam engine*, invented by an American machinist, called the *capillary steam engine*. Three great objects are said to be accomplished by this invention—*lightness, safety and economy of fuel*. In an engine calculated for a 4 horse power, the generator is formed of a copper tube,  $\frac{1}{4}$  of an inch in diameter, and 100 feet long, which weighs about 16 lbs. It is arranged in coils, one above another, in the form of a sugar loaf, 30 inches high; the bottom coil being 18 inches in diameter, and the top one considerably less. The wood is prepared as is usual for a stove, and put within the coils.—The *steam cylinder* is formed of sheet copper, 3 inches in diameter, 27 inches in stroke, and, with all its appendages, weighs about 25 lbs. It has been ascertained that the generator and main cylinder, with their contents and appendages, exclusive of fuel, need not weigh more than 20 lbs. to the horse power. *No harm can be done by the bursting of boilers*—even a safety-valve is considered as useless. In the course of the experiments, the experimenters several times burst the tube; but so far from doing any injury, it could not always be perceived by the spectators.

To ascertain what may be done toward *aerial navigation* by steam, experiments were made on the power of wings in the air, and on the power necessary to work them. The result is, that it requires a horse power to every 30 lbs. in the air; so that a flying engine, to be worked by charcoal, would weigh about 30 lbs. to the horse power, wings, condenser, and fuel included. It was also ascertained by experiments and calculations, that a balloon could be made to carry a man with an engine, which would push it at the rate of 15 miles an hour in the air. A more particular detail of these experiments may be seen in the *London Mech. Mag.*, No. 60, for 16th Oct. 1824.

"What steam is doing to facilitate intercourse by water, it is also doing on land. By means of the iron-railway, the speed of traveling in steam-carriages is treble that which is attainable by horses. The railway course is level; to accomplish which the same obstacles have to be overcome in its construction that are met with in making a canal—the high ground to be cut through and bridges to be thrown over the low. Since the railway for steam-carriages between Liverpool and Manchester was opened, a few years ago, the country has been getting intersected by others in every direction. Between these two towns, the number of passengers by this mode of conveyance averaged in 1831 about 1300 daily.—To transport all these by four-horse coaches, each allowed to carry 20 individuals, and to travel

60 miles per day, and each horse to run 20 miles, would require upward of 32 of such coaches and 390 horses. Traveling by steam is also making rapid progress on the continent and in America. Between Paris and St. Germain a substantial railway has been lately opened, with 105 vehicles, for passengers only, capable of containing 4070 persons, and of transporting the whole population of Paris to St. Germain in one day. This railway traverses no fewer than eighteen bridges, three of which are across the Seine. The rails are fifteen times heavier than those between Liverpool and Manchester. Steam-carriages have repeatedly been constructed to run on common roads; but the friction there is so great, except where the ground is very smooth, hard, and level, that, with other impediments, they have not been found to run to advantage."

Among the numerous purposes to which steam is now applied is that of breaking stones for the construction of roads. The stones are put into a kind of hopper above, and pushed down with a rake, and the machine is worked by a rotatory motion of one horse power; and will break a ton of hard pebbles, completely, in from six to eight minutes. A steam machine has also been invented for the dressing of woolen cloth, which does as much work in 50 minutes as two men could do in two days.—*Mon. Mag. Aug. 1823, p. 71.*

NOTE XII. p. 146.—*Strictures on a certain sentiment respecting the Work of Human Redemption.*

The sentiment referred to in this paragraph, "That there never was nor ever will be, through all the ages of eternity, so wonderful a display of the Divine glory as in the cross of Christ," has been frequently reiterated, in sermons and in systems of divinity, and is still repeated by certain preachers as if it were an incontrovertible axiom, which ought never to be called in question; and is no doubt intended to magnify the Divine attributes and the work of redemption. But it is nothing more than a presumptuous assumption, which has a tendency to limit the perfections of Deity, and to present a partial and distorted view of the economy of human redemption. For, in the first place, *it has no foundation in Scripture.*—There is not a single passage from which it can be legitimately deduced. The *onus probandi*, on this point, rests with those who make the assertion. A gentleman, when lately conversing on this subject, brought forward the following interrogation, as a demonstrative argument in proof of the position in question: "Is not redemption declared in Scripture to be the chief of all the works of God?" but he was not a little surprised when he was informed that the passage, which he had partly misquoted, is applied to the behemoth, or the elephant, as stated in Job, xl, 19.—2dly, The assertion is as presumptuous as it is unfounded. It takes for granted that we know all the events which have already happened, and which are now taking place throughout the whole range of God's universal empire. This empire seems unbounded; and that portion of it which we can minutely explore is but as a point in comparison of the whole. But before we can, on good grounds, hazard such an assertion as that under consideration, we must have explored all the dispensations of God, through every portion of his vast dominions; and be able to form a comparison between the different displays of divine glory made to all the different classes of intellectual beings under the govern-

ment of the Creator. And who among the sons of Adam can lay claim to such high qualifications for pronouncing so sweeping a decision on this point?—3dly, *It sets limits to the Divine perfections and operations.* For although it could be proved (which it cannot be), that no such display have hitherto been made to any other beings, yet who can take upon him to assert that displays of Divine perfections, far more glorious and astonishing, will not be exhibited during countless ages of eternity which are yet to come? To set limits to the operations of Almighty power and boundless benevolence, during the lapse of infinite duration, is not the province of any created intelligence, and far less of man, who stands so low in the scale of universal being.—4thly, *It tends to damp the hopes and prospects of immortal beings,* when looking forward to an interminable existence. For this sentiment leads them to conclude that they are already acquainted with the greatest display of Divine glory which can be made; and that, whatever scenes of wonder may be exhibited in the future world, they must of course be all inferior to this in point of extent and grandeur.

The redemption of the human race, as displayed in the Christian revelation, is a theme sufficiently grand, astonishing, and interesting to command the attention of all who are convinced that they belong to an apostate race of intelligences, and to excite the admiration and gratitude of all who have experienced its benefits; and it stands in no need of such unfounded and extravagant assertions to display its riches and glory. "Will a man speak deceitfully for God! Shall not his excellency make you afraid, and his dread fall upon you?" We pronounce nothing decisively on this subject. We feel ourselves chained down to an obscure corner of God's dominions—to be in the very infancy of our knowledge, and wihal to be connected with a race of beings whose "understandings are darkened by reason of sin;" and are, therefore, unable to pronounce an infallible decision on what God will or will not do. Were we to hazard a conjecture on this subject, we would say that the converse of the proposition under consideration is more probable than the proposition itself. We can conceive worlds ten thousand times more populous than ours, and peopled with a higher order of intellectual beings, toward whom a similar display of benevolence and mercy, were it necessary, may be made; and, therefore, in point of the extent of its objects, we can conceive the love of God more illustriously manifested than even to the inhabitants of our globe. But whether such an event shall ever take place, it would be presumption in us to determine. For the thoughts and the ways of God as far transcend ours "as the heavens are high above the earth." It demands our highest tribute of grateful adoration, that the Almighty condescended to "regard us in our low estate," and to deliver us from the moral degradation into which we had fallen; but surely it would be unreasonable to conclude, from this consideration, that of all the rational tribes which people the universe, MAN is the only favorite of the Most High, "when thousand worlds are round." Though myriads of other intelligences were to share in similar favors, it would not lessen the happiness conferred on us, nor ought it in the least to detract from our admiration of "the love of God which is in Christ Jesus our Lord."

There are a great many other vague and untenable notions which are entertained and reiterated by certain commentators and divines, as indisputable axioms, which it would be of importance



to the cause of religion to discard; such as, that angels are pure *immaterial* substances—that they were formed on the first day of the Mosaic creation—that the *wisdom* of God is nowhere so illustriously displayed throughout the universe as in the scheme of redemption—that the chief employment of the future world will be to pry into the *mysteries* of salvation—that sin is an *infinite* evil—that the whole material universe was brought into existence at the *same time* with our earth—that the Creator ceased to create any new order of beings in the universe after arranging the fabric of our globe—that the whole system of material nature in heaven and earth will be destroyed at the period of the dissolution of our world—that our thoughts and affections should be completely detached from all *created* things, etc. Several vague notions of this description are founded on the false assumption, that the globe we inhabit and the rational beings that have appeared on its surface from age to age, are the *chief objects* of God's superintendence and care—and that the Scriptures are the *only medium* through which we can view the plans and operations of the Deity—assumptions which are contrary to reason, which are unwarranted in Revelation, nay, which are directly contradicted in numerous passages of Scripture, some of which have already been referred to in the course of this volume. It would be of essential service to the cause of Christianity, that its doctrines, facts, and moral requisitions were uniformly exhibited in their native simplicity and grandeur, without being obscured and distorted by the vague and extravagant representations with which they are too frequently blended by injudicious minds.

NOTE XIII.—*Extracts from Dr. Dwight's Theology.*

As authority has a considerable degree of weight on some minds, I shall conclude with an extract on the subject of this volume, from that respectable and enlightened divine, Dr. Dwight, late President of Yale College:—"The works of God were by him intended to be, and are, in fact, manifestations of himself; proofs of his character, presence, and agency. In this light he requires men continually to regard them; and to refuse this regard is considered by him as grossly wicked, and highly deserving of punishment. Psalm xxviii, 5; Isaiah, v, 12-14. I am apprehensive that even good men are prone to pay less attention to the works of creation and providence than piety demands and the Scriptures require. We say and hear so much concerning the insufficiency of these works to unfold the character of God and the nature of genuine religion, that we are prone to consider them as almost uninformative in moral things, and in a great measure useless to the promotion of piety. This, however, is a palpable and dangerous error. The works *alone*, without the aid of the Scriptures, would, I acknowledge, be far less instructive than they now are, and utterly insufficient to guide us in the way of righteousness. The Scriptures were designed to be a comment on these works; to explain their nature, and to show us the agency, purposes, wisdom, and goodness of God in their formation. Thus explained, thus illuminated, they become means of knowledge, very extensive and eminently useful. He who does not find in the various, beautiful, sublime, awful, and astonishing objects presented to us in creation

and providence, irresistible and glorious reasons for admiring, adoring, loving, and praising his Creator, has not a claim to evangelical piety."—*System of Theology*, vol. iii, p. 477.

NOTE XIV.—*List of Popular Works on the different Sciences treated of in this volume, with occasional Remarks.*

SELECT BOOKS ON NATURAL HISTORY.

Goldsmith's History of the Earth and Animated Nature—with numerous notes from the works of the most distinguished British and foreign naturalists, embodying the most recent discoveries in natural history—illustrated by nearly 2000 figures, in 2 vols., royal 8vo., edited by Mr. Whitelaw, and published by Blackie & Son.—This edition of Goldsmith is unquestionably the most complete that has yet appeared. It contains nearly double the quantity of matter in the original work, and an account of the latest discoveries down to the period of its publication in 1840.—The Gallery of Nature and Art, by Dr. Mason Good and others, 6 vols., 8vo.—*Spectacle de la Nature*, or Nature Displayed, 7 vols., 12mo.—Nature Displayed, by Dr. Simeon Shaw, 3 vols., 8vo., or in 6 vols., 12mo. This work, though chiefly a compilation, embodies a great variety of interesting and popular descriptions of the most remarkable facts in the system of nature, which are illustrated with numerous engravings, both plain and colored. Clarke's Hundred Wonders of the World, 1 vol., 12mo., and Platt's Book of Curiosities, contain a number of interesting selections on this subject.—Smellie's Philosophy of Natural History, 2 vols., 4to., and his translation of Buffon's Natural History.—Bingley's Animal Biography, 4 vols., 8vo.—Works entitled "Systems" and "Elements" of "Natural History," are numerous; but the greater part of them is confined to descriptions of the forms, habits, and instincts of animals. On this department of natural science, a work was published some time ago by the celebrated Cuvier, entitled *The Animal Kingdom*, with engravings chiefly from the living subjects in the museum of natural history at Paris.—A work on the same subject has been publishing for several years past, in 12mo. vols., entitled *The Naturalist's Library*, by Sir W. Jardine. Every volume contains about 34 plates, with the figures colored from nature, along with a biographical sketch, and a portrait of some eminent naturalist or philosopher. About 40 vols. have already been published, price 6s. each.—A Popular and Comprehensive History of the facts which have been ascertained respecting the earth, the atmosphere, the meteors, the heavens, etc., calculated for general readers, and interspersed with appropriate moral and religious reflections, is still a *desideratum*. The facts of natural history, next to the facts recorded in the sacred volume, are the first subjects to which the minds of the young should be directed in the course of a general education.

SELECT BOOKS ON GEOGRAPHY.

Pinkerton's Modern Geography, 2 vols., 4to., and the Abridgment, 1 vol., 8vo.—The Glasgow Geography, in 5 vols., 8vo. This work comprehends an immense mass of information on the historical and descriptive parts of geography. It also contains comprehensive compends of astronomy, geology, meteorology, etc.—Malte Brun's

System of Geography, 7 vols., 8vo. The English translation of this work contains the fullest and most comprehensive view of universal geography that has yet appeared in our language, including details of the most recent discoveries. The first volume contains a luminous and comprehensive outline of the science of geology and physical and mathematical geography.—Murray's Encyclopedia of Geography, 1 vol., 8vo. This work contains a great mass of information on the subjects connected with geography, and numerous engravings.—Woodbridge's System of Universal Geography, with maps and numerous engravings.—Bell's Geography.—Myer's System of Modern Geography, with maps, views, engravings representing costumes, etc., 2 large vols., 4to.—Cooke's System of Universal Geography, in 2 very large 4to. volumes, closely printed, contains a great variety of interesting sketches in relation to *descriptive* geography, extracted from the writings of modern voyagers and travelers; the details of incidents, etc., being related, for the most part, in the words of the respective authors from whom the information is collected.—Winterbotham's Geographical and Historical View of the United States of America, etc., 4 vols., 8vo.—Morse's American Geography, 8vo.—Goldsmith's Geography on a popular plan, contains an interesting account of the manners and customs of nations, for the entertainment and instruction of the young, illustrated with above 60 engravings. Of smaller systems, there is a great abundance in the English language; but most of them are extremely deficient, particularly in what relates to *general* geography.—On *sacred* geography, Well's Geography, modernized by the Editor of Calmet's Dictionary, is the most complete work of its kind. On *physical or general* geography: Playfair's System of Geography, vol. I, and Varenus's General Geography. A *modern system* of general geography, in a separate form, on the plan of Varenus, is a *desideratum*.—Edin. Encyc., Art. *Geography*.—Encyc. Brit., 7th edition, Art. *Physical Geography*, etc. Books of Voyages and Travels generally contain the most circumstantial details of the physical aspects of the different countries, and of the dispositions and customs of their inhabitants; and present to the view of the Christian philanthropist those facts and principles from which the *moral* state and character of the various tribes of human beings may be inferred. The following works contain comprehensive abridgments of the most celebrated voyages and travels:—Pinkerton's General Collection of Voyages and Travels in all parts of the World, 17 vols., 4to.—Mavor's Voyages, etc., 23 vols., 18mo.—The World Displayed, 18 vols., 18mo.—Phillips's Collection of Voyages and Travels, etc.—Conder's Modern Traveler, 29 vols.

The following are among the most respectable modern publications on this subject, arranged according to the different quarters of the world:—AsIA. Valencia's Travels in India, Arabia, etc.—Porter's Travels in Georgia, Armenia, etc.—Gallowin's Travels in Japan.—Staunton's Account of Macartney's Embassy to China.—Raffles' Travels in Java.—Clarke's Travels in Asia Minor and the Holy Land.—Chateaubriand's Travels in Palestine.—Ali Bey's Travels in Arabia.—Sir Alexander Burness's Travels in India, etc.—Stephens' Incidents of Travel in Egypt, Arabia Petrea, and the Holy Land.—Morier's Travels through Persia.—Historical and Descriptive Account of British India, 3 vols.—Historical and Descriptive Account of China, 3 vols.—Crichton's History of Arabia.—Frazer's Account of Persia.—Russell's Palestine,

etc.—AFRICA. Lyon's Travels in Northern Africa.—Burchardt's Travels in Nubia.—Bruce's Travels in Abyssinia.—Salt's Travels in Abyssinia.—Bowditch's, Hutton's, and Dupuis's Account of Ashantee.—Park's and Lander's Travels in Africa.—Leigh's Journey in Egypt.—Belzoni's Travels in Egypt.—Sonini's Travels in Egypt.—Barrow's, Bennell's, and Campbell's Travels in Southern Africa.—Russell's Account of Nubia, Abyssinia, and the Barbary States, and View of Ancient and Modern Egypt.—Narrative of Discovery and Adventure in Africa, with Illustrations of the Geology, Mineralogy, and Zoology, etc.—AMERICA. Howison's Sketches of Upper Canada.—Stewart's Three Years in America.—Tytier's Views of the Northern Coast of America.—Humboldt's Travels in South America.—Duncan's Travels in the United States.—Miss Martineau's Society in America.—Baskinghan's Travels in the United States of America.—Lucecock's, Vidal's, Koster's, and Hall's Travels in South America, etc.—EUROPE. Henderson's and Mackenzie's Travels in Iceland.—Thomson's Travels in Sweden.—Carr's Travels in Russia, Denmark, etc.—Pallas's Travels in Russia.—Wraxall's, Neale's, Coxe's, and Lemaistre's Tours through France, Switzerland, Germany, etc.—Burgoin's and Jacob's Travels in Spain.—Brydone's Tour in Sicily, etc.—Von Bueck's Travels in Norway and Lapland.—Cochrane's Travels in Siberia, etc.—Cooke's, Anson's, Byron's, Perouse's, and Bonganville's Voyages round the World, etc.—Prior's Universal Traveler, 1 thick vol., 12mo., closely printed, with 100 engravings.

## SELECT BOOKS ON GEOLOGY.

Kirwin's Mineralogy, and his Geological Essays.—De Luc's Geology, and his Geological Travels.—Parkinson's Organic Remains of a former world, 3 vols., 4to.—The Fossils of the South Downs, or Illustrations of the Geology of Sussex, by G. Mantel, F.L.S.—The preliminary Essay to this splendid Work contains several excellent remarks respecting the connection of Geology with Religion, which are calculated to advance the interests of both.—Cuvier's Essay on the theory of the Earth, with Illustrations by Professor Jamieson, 4th edition.—Playfair's Illustrations of the Huttonian Theory of the Earth.—Transactions of the Geological and Wernerian Societies.—Dr. P. Smith's Lectures on Geology as connected with Revelation.—Dr. Hitchcock's Treatise on Geology—his Connection between Geology and Natural Religion—and his Connection between Geology and the Mosaic Account of the Creation.—Lyell's Geology.—Buckland and Babbage's Bridgewater Treatises.—Macculloch's System of Geology.—Hugh Miller's Old Red Sandstone.—Buckland's Account of the discovery of a Den of Hyenas in a cavern in Yorkshire.—Buckland's Treatise on Geology, 2 vols., 8vo.—Bakewell's Introduction to Geology.—Phillips's Outlines of Mineralogy and Geology, 12mo.—This last work forms a good introduction to the study of Geology, for those who are just commencing their inquiries on this subject. The object of this science, in the meantime, should be confined chiefly to the *collecting of facts*, in reference to the structure of the earth and the changes it has undergone. The exterior aspect of our globe, and its internal recesses, must be still more extensively explored, before any theory of the earth can be established on a broad and solid foundation. It should be left to future ages to build a system with the materials we are now preparing.

## POPULAR WORKS ON ASTRONOMY.

Brewster's Ferguson's Astronomy, 2 vols., 8vo., with a vol. of plates. The notes and supplementary chapters of this work, written by Sir D. Brewster, contain a full and comprehensive detail of all the modern discoveries in this science.—Bonnycastle's Introduction to Astronomy, 1 vol., 8vo.—La Place's System of the World, 2 vols., 8vo.—Dr. Olinthus Gregory's Astronomy, 1 vol., 8vo.—Mrs. Bryan's System of Astronomy, 8vo.—Adams' Astronomical and Geographical Essays, 8vo.—Phillips's Eight Familiar Lectures on Astronomy, 12mo.—Herschel's Astronomy.—Squire's Grammar of Astronomy, one thick vol. 18mo., closely printed, and illustrated with 35 plates.—Arago's Lectures on Astronomy.—The Wonders of the Heavens, 12mo.—This work contains a popular view of the principal facts of Astronomy, and is illustrated with 50 elegant engravings of a variety of interesting objects connected with the scenery of the heavens; but its discussions are too frequently blended with the peculiarities of a modern physical theory.—Martin's Gentleman and Lady's Philosophy, vol. 1.—Derham's Astro-Theology, and Whiston's Astronomical Principles of Religion, 8vo.—Baxter's Matho, 2 vols., etc.—An elegant and comprehensive outline of the leading facts of Astronomy in their relation to Revealed Religion, will be found in Dr. Chalmers's Discourses on the Christian Revelation, viewed in connection with Modern Astronomy, 8vo.—The general reader, in commencing his study of this science, will find Bonnycastle's "Introduction" a very interesting work. It is written in an elegant and animated style, and is agreeably interspersed with a number of appropriate reflections; but it is deficient in the detail of modern discoveries. He might next proceed to the perusal of Ferguson, Gregory, Squire, etc.—La Place's work contains a beautiful exposition of the Newtonian system; but it is glaringly deficient in reference to the Wisdom and Agency of a Supreme Intelligence. "An undevout astronomer is mad." Baxter's Matho contains a popular and interesting view of this subject, and forms a striking contrast to the apathy of La Place, who carefully keeps out of view the agency of the Creator—the main design of this author being to connect the phenomena of the heavens and the earth with the attributes of Deity, and the high destination of immortal minds. Though this work passed through three editions, it does not seem to have been appreciated according to its merits. As it has now become scarce, a new edition with notes, containing a detail of modern discoveries, might be an acceptable present to the public. Those who wish to prosecute this subject to a greater extent, may be referred to Long's Astronomy, 2 vols., 4to.—Robison's Mechanical Philosophy, vol. 1.—Dr. Pearson's Introduction to Practical Astronomy, comprising descriptions of Telescopes, Equatorials, Quadrants, and other astronomical instruments, 2 large vols., 4to., with numerous engravings of instruments.—Vince's complete System of Astronomy, 3 vols., 4to.—La Lande Astronomie, 3 vols., 4to.—and Biot's Traité Élémentaire d'Astronomie Physique. A comprehensive work on *Descriptive Astronomy*, detailing in a popular manner, all the facts which have been ascertained respecting the scenery of the heavens, accompanied with a variety of striking delineations, and interspersed with appropriate moral reflections, accommodated to the general reader, is a  *desideratum*  which we trust will be in some measure supplied by the two volumes we lately published,

entitled "Celestial Scenery," and the "Sidereal Heavens," which have already passed through several editions, and have been republished in different parts of America.

## SELECT BOOKS ON NATURAL PHILOSOPHY.

Hauy's Elementary Treatise on Natural Philosophy, translated by Dr. O. Gregory, 2 vols., 8vo. This translation contains a number of valuable notes by the translator.—Ferguson's Lectures on Select subjects in Mechanics, etc., by Sir D. Brewster, 2 vols., 8vo., with a vol. of plates. The Appendix to this work, by Sir D. Brewster, contains a mass of valuable information on Mechanics, Hydraulics, Dialing, and the construction of *Optical Instruments*; beside a variety of illustrative notes interspersed through the work, which comprises a detailed account of the recent discoveries in Experimental Philosophy.—Nicholson's Introduction to Natural Philosophy, 2 vols., 8vo.—Cavallo's Complete Treatise on Natural and Experimental Philosophy, 4 vols., 8vo.—Martin's Philosophia Britannica, 3 vols., 8vo.; his Gentleman and Lady's Philosophy; 3 vols., 8vo.; and his Philosophical Grammar, 1 vol., 8vo.—Herschel's Preliminary Discourses on the study of Natural Philosophy.—Lardner's Hydrostatics, Mechanics, and Pneumatics.—Professor Quetelet's Facts, Laws, and Phenomena of Natural Philosophy.—Partington's Manual of Natural and Experimental Philosophy, 2 vols., 8vo.—Sir D. Brewster's Treatise on Optics.—Smith's Complete System of Optics, 2 vols., 4to., with 93 plates, containing 941 figures, 1738.—Arnot's Elements of Physics, 2 vols., 8vo.—Gregory's Economy of Nature, 3 vols., 8vo.; and his Lectures on Experimental Philosophy, Astronomy, and Chemistry, 2 vols., 12mo.—Joyce's Letters on Experimental Philosophy, 2 vols., 12mo.; and his Scientific Dialogues, 18mo.—Adams' Lectures on Natural and Experimental Philosophy, 4 vols., 8vo., with a vol. of plates.—Young's Lectures on Natural Philosophy, 2 vols., 8vo.—Walker's System of familiar Philosophy, 4to., in 12 lectures, with 47 4to. engravings.—Conversations on Natural Philosophy by the author of Conversations on Chemistry, one thick vol., 12mo., with 23 engravings.—Blair's Grammar of Natural Experimental Philosophy, especially the late editions, contains (at a small price), a comprehensive view of the principal departments of Philosophy, including Astronomy, Geology, Chemistry, Meteorology, etc.—Euler's Letters to a German Princess, 2 vols., 8vo., contains a popular view of the most interesting subjects connected with Natural and Experimental Philosophy, Logic, and Ethics. This work is distinguished by a vein of dignified and scriptural piety, which runs through every part of it. Euler was one of the most distinguished Philosophers and Mathematicians of his day. He died in 1783, at the age of 77. An edition of this work, containing *Notes by Sir D. Brewster*, has been published. These notes are excellent, so far as they extend; but it is to be regretted that they are so sparingly distributed, and that the passages suppressed by M. Condorcet and De la Croix, which were restored by Dr. Hunter, who translated the work, and the notes of the French and English editors, are for the most part discarded. As a work of general information in relation to the physical sciences and other useful departments of knowledge, Chambers's *Information for the People* may be recommended to common readers, as a very useful and comprehensive compend of Science, History, Civil and Natural Geography, Ve-

getable and Animal Physiology, Chemistry, Electricity, Magnetism, etc. It is the cheapest book that has hitherto been published, when we consider the quantity of letter-press, and the vast mass of information it contains.

Notwithstanding the numerous excellent treatises which are to be found on this subject, a comprehensive work on experimental Philosophy, blended with sketches of those parts of natural history which are connected with it, and enlivened with appropriate reflections on the peculiar agencies of Deity, which appear in the various processes of nature—is still wanting to interest the general reader, and to attract his attention to this department of knowledge. Were philosophers, in their discussions of natural science, more frequently to advert to the agency of the Deity, and to point out the Religious and Philanthropic purposes to which modern discoveries might be applied, they might be the means of promoting, at the same time, the interests both of science and religion, by alluring general readers to direct their attention to such objects, and by removing those groundless prejudices which a great proportion of the Christian world still entertain against philosophical studies. About the period when Boyle, Ray, Derham, Nieuwentyt, Whiston, Addison, the Abbe Pluche, and other Christian philosophers flourished, more attention seems to have been paid to this subject than at present. Since the middle of the last century, the piety of philosophers appears to have been greatly on the decline. It is to be hoped that it is now beginning to experience a revival. But whatever may be the varying sentiments and feelings of mere philosophers, in reference to the agencies of the material system, “all the works of God *invariably* speak of their Author,” to the humble and enlightened Christian; and if he be directed to contemplate the order of nature with an eye of intelligence, he will never be at a loss to trace the footsteps and the attributes of his Father and his God.

#### SELECT BOOKS ON CHEMISTRY

Davy's Elements of Chemical Philosophy, 8vo.—Ure's Dictionary of Chemistry, on the basis of Mr. Nicholson's, 1 large vol., 8vo.—Henry's Epitome of Chemistry, 2 vols., 8vo.—Accum's Chemistry, 2 vols., 8vo.—Thomson's System of Chemistry, 4 vols., 8vo.—Murray's System of Chemistry, 4 vols., 8vo., and Appendix.—Kerr's Translation

of Lavoisier's Elements of Chemistry, 8vo.—Chaptal's Chemistry applied to the Arts, 4 vols., 8vo.—Fourcroy's Chemistry, 4 vols.—Accum's Chemical Amusements, and Griffin's Chemical Recreations, contain a description of a variety of interesting chemical facts, and amusing experiments.—Gurney's Lectures on the Elements of Chemical Science, 8vo.—Mackenzie's One Thousand Experiments in Chemistry, etc.—Mitchell's Dictionary of Chemistry.—Graham's Chemical Catechism.—Donovan's Treatise on Chemistry, in Lardner's Cyclopaedia.—Turner's Chemistry.—Conversations on Chemistry, by a Lady, 2 vols., 12mo.—Joyce's Dialogues on Chemistry, 2 vols., 18mo.—Parke's Rudiments of Chemistry, 18mo, and his Chemical Catechism, 8vo. The four works last mentioned may be recommended as popular introductions to the study of this science.—Parke's Rudiments and Catechism are distinguished by their constant reference to the agency of the Deity, and by the anxiety which the author displays to fix the attention of his readers on the evidences of benevolent design which appear in the constitution of nature. The numerous notes appended to the Chemical Catechism embody a great variety of interesting facts in reference to the economy of nature, and the processes of the arts. To this amiable and intelligent writer I feel indebted for several of the chemical facts stated in this volume.

As the science of Chemistry is making rapid progress in its investigations and discoveries—the latest editions of the works referred to, and all others on the same subject, are generally to be preferred. The same remark is applicable to almost all the works connected with the physical sciences. But, with the exception of new discoveries, many of the works published twenty or thirty years ago, are worthy of being consulted, and are, in some respects, superior to more recent publications. There are some works, on different branches of natural science, published nearly a century ago, which give more full and clear descriptions of certain scientific facts than are to be found in many of our modern publications: and therefore such works ought not to be considered as altogether obsolete. It is of some importance to the student of science to be possessed of several treatises on the same subject; as certain principles or facts which may be vaguely stated, or imperfectly explained by one author, may be more fully and clearly elucidated by another

CELESTIAL SCENERY;

OR,

THE WONDERS

OF

THE PLANETARY SYSTEM DISPLAYED;

ILLUSTRATING

THE PERFECTIONS OF DEITY

AND A PLURALITY OF WORLDS.



## P R E F A C E .

---

THE following work is intended for the instruction of general readers, to direct their attention to the study of the heavens, and to present to their view sublime objects of contemplation. With this view the author has avoided entering on the more abstruse and recondite portions of astronomical science, and confined his attention chiefly to the exhibition of *facts*, the foundation on which they rest, and the reasonings by which they are supported. All the prominent facts and discoveries connected with descriptive astronomy, in so far as they relate to the planetary system, are here recorded, and many of them exhibited in a new point of view; and several new facts and observations are detailed which have hitherto been either unnoticed or unrecorded.

The results of hundreds of tedious calculations have been introduced respecting the solid and superficial contents of the different planets, their satellites, and the rings of Saturn; their comparative magnitudes and motions, the extent of their orbits, the apparent magnitudes of bodies in their respective firmaments, and many other particulars not contained in books of astronomy, in order to produce in the minds of common readers definite conceptions of the magnitude and grandeur of the solar system. The mode of determining the distances and magnitudes of the celestial bodies is explained, and rendered as perspicuous and popular as the nature of the subject will admit; and the prominent arguments which demonstrate a plurality of worlds are considered in all their bearings, and illustrated in detail.

One new department of astronomical science, which has hitherto been overlooked, has been introduced into this volume, namely, *the scenery of the heavens as exhibited from the surfaces of the different planets and their satellites*, which forms an interesting object of contemplation, and, at the same time, a presumptive argument in favor of the doctrine of a plurality of worlds.

The author, having for many years past been a pretty constant observer of celestial phenomena, was under no necessity of adhering implicitly to the descriptions given by preceding writers, having had an opportunity of observing, through some of the best reflecting and achromatic telescopes, the greater part of the phenomena of the solar system which are here described.

Throughout the volume he has endeavored to make the facts he describes bear upon the illustration of the Power, Wisdom, Benevolence, and the Moral Government of the Almighty, and to elevate the views of the reader to the contemplation of HIM who sits on the throne of the universe, "by whom the worlds were framed," and who is the Source and Center of all felicity.

In prosecuting the subject of Celestial Scenery, the author intends, in another volume, to carry forward his survey to the STARRY HEAVENS and other objects con-

nected with astronomy. That volume will embrace discussions relative to the number, distance, and arrangement of the stars; periodical and variable stars; new and temporary stars; double and triple stars; binary systems; stellar and planetary nebulæ; the comets, and other particulars; accompanied with such reflections, as the contemplation of such august objects may suggest. The subject of a plurality of worlds will likewise be prosecuted, and additional arguments, derived both from reason and Revelation, will be adduced in support of this position. The practical utility of astronomical studies, their connection with religion, and the views they unfold of the perfections and the empire of the Creator, will also be the subject of consideration. And should the limits of a single volume permit, some hints may be given in relation to the *desiderata* in astronomy, and the means by which the progress of the science may be promoted, together with descriptions of the telescope, the equatorial, and other instruments, and the manner of using them for celestial investigation.

BROUGHTY FERRY, NEAR DUNDEE.



# CONTENTS.

## INTRODUCTION.

	PAGE
Objects and sublimity of the science of astronomy. Ignorance of former ages on this subject.	
Modern Discoveries—object of this work .....	9

## CHAPTER I.

### ON THE GENERAL APPEARANCE AND APPARENT MOTIONS OF THE STARRY HEAVENS.

Ignorance of the bulk of mankind in regard to the apparent motions of the heavens.	
Deficiencies in our modes of education. Innate curiosity of the young. Apparent motions and phenomena of the nocturnal heavens. How to find the pole-star. Description of <i>Ursa Major</i> and <i>Minor</i> . Situations of some of the principal stars. Appearance of the firmament in southern latitudes. Magnificence of the starry heavens. Proofs of the earth's rotation.	
Utility of the stars. Measures of the celestial sphere.....	11

## CHAPTER II.

### ON THE GENERAL ARRANGEMENT OF THE PLANETARY SYSTEM.

Ptolemaic system—its complexity and futility. Copernicus. System of Copernicus—its important bearings. Arguments to prove the truth of this system, and of the earth's annual motion, <i>illustrated at large</i> . Motion of the earth a sublime object of contemplation.....	19
--	----

## CHAPTER III.

### ON THE MAGNITUDES, MOTIONS, AND OTHER PHENOMENA OF THE BODIES CONNECTED WITH THE SOLAR SYSTEM.

#### 1. *The Planet Mercury.*

Its period—elongation—transits—mountains— <i>intensity of light</i> — <i>temperature</i> —magnitude and population—rate of motion—mass and density—eccentricity of orbit, &c.....	27
---	----

#### 2. *The Planet Venus.*

Form of the Planetary orbits. Explanation of astronomical terms. General appearance, phases, and apparent motions of Venus. May be seen at its <i>superior</i> conjunction. Observations on in the day-time. Discoveries on by the telescope. Views of by Cassini, Bianchini, Maraldi, Schroeter, and others. Its mountains and atmosphere. Its supposed satellite—its transits—extent of surface—quantity of light—temperature—distance—rate of motion, density, &c.....	29
---	----

#### 3. *The Earth considered as a Planet.*

Its spheroidal figure, and how ascertained—general aspect of its surface—appearance if viewed from the moon—its <i>internal structure</i> and <i>density</i> —its variety of <i>seasons</i> —general reflections on—its tropical and sidereal year, and various other particulars.....	39
--	----

#### 4. *The Planet Mars.*

Peculiar phenomena of the <i>superior</i> planets. Conjunctions, oppositions, and phases of Mars—distance, motion, apparent diameter, and extent of its orbit—telescopic views of its surface--	( v )
---	-------

its atmosphere—conclusions respecting its physical constitution—its superficial contents—proportion of light—whether it have a secondary attendant, &c.....	45
<i>5. The Planets Vesta, Juno, Ceres, and Pallas.</i>	
History of their discovery. Notice of Dr. Olbers. Magnitude, distances, periods, and other phenomena of these planets—their <i>peculiarities</i> —inclination and eccentricity of orbits, &c., &c. <i>Conclusions respecting the nature of these planets.</i> Remarks in reference to the Divine government. Meteoric phenomena. Details of meteoric showers, with remarks. Moral reflections, &c.....	51
<i>6. The Planet Jupiter.</i>	
Its distance—diurnal rotation—centrifugal force—density—magnitude and capacity for population. Discoveries made on its surface by means of the telescope. Its belts—their changes and general phenomena. Opinions respecting their nature. Its permanent spots. Its peculiar splendor. Its seasons—atmosphere—proportion of light—spheroidal figure—arc of retrogradation, &c.....	59
<i>7. The Planet Saturn.</i>	
Its distance—period of revolution and proportion of light. Discoveries on its surface by means of the telescope. Magnitude and extent. Its <i>density</i> . Gravitating power of the planets, &c., &c.....	64
<i>8. Rings of Saturn.</i>	
History of their discovery. Their dimensions—rotation—arc eccentric. Their superficial contents and vast extent illustrated. Display the grandeur of the Creator. Their appearance from the surface of Saturn. Their diversified phenomena. Firmament of Saturn described. <i>Uses of the rings.</i> Different aspects of the rings as viewed through telescopes.....	66
<i>9. The Planet Uranus.</i>	
History of its discovery. Its distance. Circumference of its orbit. Its period of revolution. Its magnitude and dimensions. Its proportion of <i>light</i> . Its temperature. Nature of caloric, &c.....	72
Whether any other planets exist within the limits of our system, and how they may be discovered.	75
<i>10. The Sun.</i>	
Its apparent <i>diurnal</i> motion as viewed from different positions on the globe—its <i>annual</i> motion—its distance—its <i>magnitude</i> particularly illustrated with reflections—its rotation. Phenomena of its spots particularly described—their variety and changes—opinions respecting them. Deductions respecting the nature and constitution of the sun. Amazing operations going forward on its surface. The extent of its surface compared with the view from Mount Etna. Displays the grandeur of the Deity. Whether it be inhabited. Its beneficial influence on our globe. Its effect on the weather. Its motion in space. Zodiacal light.....	76

## CHAPTER IV.

### ON THE SECONDARY PLANETS.

#### *1. The Moon.*

Its apparent motions and phases—rotation—opacity—distance—variety of mountains—caverns—volcanoes—telescopic views of—atmosphere—magnitude—inhabitants—pretended discoveries on—beneficial influence, &c.....	85
--	----

#### *2. The Satellites of Jupiter.*

Their discovery—revolutions—eclipses—magnitudes—diversity of phenomena—longitude—motion of light.....	95
---	----

#### *3. Satellites of Saturn.*

History of their discovery—revolutions and assumed magnitudes—appearance from Saturn...	98
---	----

4. *Satellites of Uranus.*

Their motions—distances—assumed magnitudes and peculiarities.....	99
---	----

## CHAPTER V.

## ON THE PERFECTIONS OF THE DEITY, AS DISPLAYED IN THE PLANETARY SYSTEM.

Grand object of astronomy. <i>Omnipotence</i> of the Deity—displayed in the magnitudes and motions of the sun and planets. His <i>wisdom</i> illustrated in various particulars. His boundless beneficence.....	100
---	-----

## CHAPTER VI.

## SUMMARY VIEW OF THE PLANETARY SYSTEM.

Superficies, solidity, comparative magnitudes and distances of the sun, earth, planets, satellites and rings of Saturn.....	105
---	-----

## CHAPTER VII.

## ON THE METHOD BY WHICH THE DISTANCES AND MAGNITUDES OF THE HEAVENLY BODIES ARE DETERMINED.

Popular methods illustrated. Law of shadows. Eclipses. Trigonometrical definitions. Parallaxes. Triangles. Mode of calculating the distance and diameter of the moon. General remarks.....	107
--	-----

## CHAPTER VIII.

## ON THE SCENERY OF THE HEAVENS AS VIEWED FROM THE SURFACES OF THE DIFFERENT PLANETS AND THEIR SATELLITES.

General remarks on celestial scenery. Scenery of the heavens from Mercury—Venus—Mars—the new planets—Jupiter—Saturn—Uranus—rings of Saturn. Celestial scenery of the moon. Appearance of the earth from. Lunar astronomy. Scenery from the satellites of Jupiter—of Saturn—and of Uranus. Various views of these scenes. General observations..	114
---	-----

## CHAPTER IX.

## ON THE DOCTRINE OF A PLURALITY OF WORLDS, WITH AN ILLUSTRATION OF SOME OF THE ARGUMENTS BY WHICH IT MAY BE SUPPORTED.

First argument illustrated.....	126
Second argument.....	127
Third argument.....	129
Application of the preceding arguments.....	132
Fourth argument.....	133
Fifth argument.....	134
Summary—concluding reflections.....	137

## APPENDIX.

Descriptions of Celestial phenomena, and of the positions and aspects of all the planets during the years 1838 and 1839 .....	137
---	-----



# CELESTIAL SCENERY.

## INTRODUCTION.

ASTRONOMY is that department of knowledge which has for its object to investigate the motions, the magnitudes, and distances of the heavenly bodies; the laws by which their movements are directed, and the ends they are intended to subserve in the fabric of the universe. This is a science which has in all ages engaged the attention of the poet, the philosopher, and the divine, and been the subject of their study and admiration. Kings have descended from their thrones to render it homage, and have sometimes enriched it with their labors; and humble shepherds, while watching their flocks by night, have beheld with rapture the blue vault of heaven, with its thousand shining orbs, moving in silent grandeur, until the morning star announced the approach of day. The study of this science must have been coeval with the existence of man; for there is no rational being who has for the first time lifted his eyes to the nocturnal sky, and beheld the moon walking in brightness amidst the planetary orbs and the host of stars, but must have been struck with admiration and wonder at the splendid scene, and excited to inquiries into the nature and destination of those far-distant orbs. Compared with the splendor, the amplitude, the august motions, and the ideas of infinity which the celestial vault presents, the most resplendent terrestrial scenes sink into inanity, and appear unworthy of being set in competition with the glories of the sky.

When, on a clear autumnal evening, after sunset, we take a serious and attentive view of the celestial canopy; when we behold the moon displaying her brilliant crescent in the western sky; the evening star gilding the shades of night; the planets moving in their several orbs; the stars, one after another, emerging from the blue ethereal, and gradually lighting up the firmament until it appear all over spangled with a brilliant assemblage of shining orbs; and particularly when we behold one cluster of stars gradually descending below the *western* horizon, and other clusters emerging from the *east*, and ascending, in unison, the canopy of heaven; when we contemplate the whole celestial vault, with all the shining orbs it contains, moving in silent grandeur, like one vast concave sphere, around this lower world and the place on which we stand—such a scene naturally leads a reflecting mind to such inquiries as these: Whence come those stars which are ascending from the east? Whither have those gone which have disappeared in the west? What becomes of the stars during the day which are seen in the night? Is the motion which appears in the celestial vault *real*, or does a motion in the earth itself cause this appearance? What are those immense numbers of shining orbs which appear in every part of the sky? Are they mere studs or tapers fixed in the arch of heaven, or are they bodies of immense size and splendor? Do they shine with borrowed

light, or with their own native luster? Are they placed only a few miles above the region of the clouds, or at immense distances beyond the range of human comprehension? Can their distance be ascertained? Can their bulk be computed? By what laws are their motions regulated? and what purposes are they destined to subserve in the great plan of the universe? These, and similar questions, it is the great object of astronomy to resolve, in so far as the human mind has been enabled to prosecute the path of discovery.

For a long period, during the infancy of science, comparatively little was known of the heavenly bodies excepting their apparent motions and aspects. Instead of investigating with care their true motions, and relative distances and magnitudes, many of our ancestors looked up to the sky either with a brute unconscious gaze, or viewed the heavens as the book of fate, in which they might read their future fortunes, and learn, from the signs of the zodiac, and the conjunctions and other aspects of the planets, the temperaments and destinies of men and the fate of empires. And even to this day, in many countries, the fallacious art of prognosticating fortunes by the stars is one of the chief uses to which the science of the heavens is applied. In the ages to which I allude, the world in which we dwell was considered as the largest body in the universe. It was supposed to be an immense plane, diversified with a few inequalities, and stretching in every direction to an indefinite extent. How the sun penetrated or surmounted this immense mass of matter every morning, and what became of him in the evening—whether, as the poets assert, he extinguished himself in the western ocean, and was again lighted up in the eastern sky in the morning—many of them could not determine.—*Below* this mass of matter we call the earth, it was conceived that nothing but darkness and empty space, or the regions of Tartarus, could exist. The stars which gild the concave of the firmament *above* were considered only as so many bright studs fixed in a crystalline sphere, which carried them round every day to emit a few glimmering rays, and to adorn the ceiling of our terrestrial habitation. Above the visible firmament of heaven, and far beyond the ken of mortal eye, the Deity was supposed to have fixed his special residence, among myriads of superior intelligences. The happiness, the preservation, and the moral government of the human race were supposed to be the chief business and object of the Deity, to which all his decrees in eternity past, and all his arrangements in relation to eternity to come, had a special and almost exclusive reference. Such ideas are still to be found, even in the writings of Christian divines, at a period no further back than the sixteenth century.

To hazard the opinion that the plans of the Almighty embraced a much more extensive range—

that other beings, analogous to men, inhabited the planetary or the starry orbs, and that such beings form by far the greater part of the population of the universe—would have been considered as a heresy in religion, and would probably have subjected some of those who embraced it to the anathemas of the church, as happened to Spigelius, bishop of Upsal, for defending the doctrine of the antipodes, and to Galileo, the philosopher of Tuscany, for asserting the motion of the earth. The ignorance, the intolerance, and the contracted views to which I allude, are, however, now, in a great measure, dissipated. The light of science has arisen, and shed its benign influence on the world. It has dispelled the darkness of former ages, extended our prospects of the grandeur and magnificence of the scene of creation, and, in conjunction with the discoveries of revelation, has opened new views of the perfections and moral government of the Almighty. In the progress of astronomical science, the distances and magnitudes of many of the celestial bodies began to be pretty nearly ascertained; and the invention of the *telescope* enabled the astronomer to extend his views into regions far beyond the limits of the unassisted eye, and to discover myriads of magnificent globes formerly hid in the unexplored regions of immensity. The planetary orbs were found to bear a certain resemblance to the earth, having spots and dark streaks of different shades upon their surfaces; and it was not long in being discovered that, notwithstanding their apparent brilliancy, they are, in reality, opaque globes, which derive all their light and luster from the sun. The planet Venus, in different parts of its orbit, was observed to exhibit a gibbous phase, and the form of a crescent similar to the moon, plainly indicating that it is a dark globe, enlightened only on one side by the rays of the sun.—The moon was perceived to be diversified with hills and valleys, caverns, rocks, and plains, and ranges of mountains of every shape, but arranged in a manner altogether different from what takes place in our sublunary sphere. The sun, which was generally supposed to be a ball of liquid fire, was found to be sometimes covered with large dark spots, some of them exceeding in size the whole surface of the terraqueous globe, and giving indications, by their frequent changes and disappearance, of vast operations being carried on upon the surface and in the interior of that magnificent luminary. Hundreds of stars were described where scarcely one could be perceived by a common observer; and as the powers of the telescope were increased, thousands more were brought to view, extending in every direction, from the limits of unassisted vision throughout the boundless extent of space.

It is natural for an intelligent observer of the universe to inquire into the final causes of the various objects which exist around him. When he

beholds the celestial regions filled with bodies of an immense size, arranged in beautiful and harmonious order, and performing their various revolutions with regularity and precision, the natural inquiry is, For what end has the Deity thus exerted his wisdom and omnipotence? What is the ultimate destination of those huge globes which appear in the spaces of the firmament? Are these vast masses of matter suspended in the vault of heaven merely to diversify the voids of infinite space, or to gratify a few hundreds of terrestrial astronomers in peeping at them through their glasses? Is the Almighty to be considered as taking pleasure in beholding a number of splendid lamps, hung up throughout the wilds of immensity, which have no relation to the accommodation and happiness of intelligent minds? Has he no end in view corresponding to the magnificence and grandeur of the means he has employed! Or, are we to conclude that his wisdom and goodness are no less conspicuously displayed than his omnipotence in peopling those vast bodies with myriads of intelligent existences of various orders, to share in his beneficence and to adore his perfections? This last deduction is the only one which appears compatible with any rational ideas we can entertain of the wisdom and intelligence of the Eternal Mind, and the principles of the Divine government.

This opinion is now very generally entertained by those who have turned their attention to the subject. But it is frequently admitted on grounds that are too general and vague; on the authority of men of science, or on the mere ground that the planets and stars are bodies of immense size; and hence it is only considered as a *probable* opinion, and a *thorough conviction* of its truth is seldom produced in the mind.

In the following work it shall be our endeavor to show that the arguments which may be brought forward to establish the doctrine of a plurality of worlds have all the force of a *moral demonstration*; that they throw a luster on the perfections of the Divinity; and that the opposite opinion is utterly inconsistent with the every idea we ought to entertain of an All-wise and Omnipotent Intelligence.

In order to the full illustration of this subject, it will be necessary to take a pretty minute and comprehensive view of all the known facts in relation to the heavenly bodies; and while these facts will be made to bear upon the object now proposed, they will likewise tend to exhibit the scenery of the heavens, and to elucidate many of the prominent truths and principles connected with descriptive astronomy. In the progress of our discussions, we shall descend into many minute particulars which are generally overlooked by writers on the subject of astronomy, and shall introduce several original observations and views on this subject which have not hitherto been particularly detailed.

## CHAPTER I.

### ON THE GENERAL APPEARANCE AND APPARENT MOTIONS OF THE STARRY HEAVENS.

BEFORE proceeding to a particular description of the real magnitudes, motions, and phenomena of the heavenly bodies, it may not be improper to take a brief survey of the general appearance and apparent motions of the celestial vault, as they present themselves to the eye of a common observer.

It is of importance to every one who wishes to acquire a clear idea of the principles of astronomy and the phenomena of the heavens, that he contemplate with his own eyes the *apparent* aspects and revolutions of the celestial bodies before he proceeds to an investigation of the *real* motions, phenomena, and arrangements which the discoveries of science have led us to deduce. From want of attention to this circumstance, there are thousands of smatterers in the science of astronomy who never acquire any clear or comprehensive ideas on this subject; and who, instead of clearly perceiving the relations of the heavenly orbs from their own observation, rely chiefly on the assertions of their instructors, or the vague descriptions to be found in elementary books. It is amazing how many intelligent men there are among us who would not wish to be considered altogether ignorant of modern astronomy, have never looked up to the celestial vault with fixed attention; have never made repeated observations to discover its phenomena; and cannot tell, from their own survey, what are the various motions it exhibits. There are thousands and ten thousands who have gazed on a clear evening sky, at certain intervals, during a period of many years, yet can tell no more about the glorious scene around them than that they behold a number of shining points twinkling in every direction in the canopy above. Whether these bodies shift their positions with regard to each other, or remain at the same relative distances; whether any of them appear in motion, while others appear at rest; whether the whole celestial canopy appears to stand still, or is carried round with some general motion; whether all the stars which are seen at six o'clock in the evening are also visible at twelve at midnight; whether the stars rise and set, as the sun and moon appear to do; whether they rise in the east, or north-east, or in any other quarter; whether some rise and set regularly, while others never descend below the horizon; whether any particular stars are occasionally moving backward or forward, and in what parts of the heavens they appear; whether there are stars in our sky in the daytime as well as during night; whether the same clusters of stars are to be seen in summer as in winter? To these and similar questions there are multitudes who have received a regular education, and who are members of a Christian church, who could give no satisfactory answers. And yet almost every one of these inquiries could be satisfactorily answered, in the course of a few evenings, by any man of common understanding who

directed his attention for a few hours to the subject, and that, too, without the knowledge of a single scientific principle. He has only to open his eyes, and to make a proper use of them; to fix his attention on the objects before him; to make one observation after another; and to compare them together; and to consider that "the works of the Lord are *great*," and that they ought "to be sought out [or seriously investigated] by all those who have pleasure therein."

If this representation be admitted as just, what a striking idea does it present of the *apathy* and indifference of the greater part of mankind in regard to the most astonishing and magnificent display which the Creator has given of himself in his works! Had we an adequate conception of all the scenes of grandeur, and the displays of intelligence and omnipotent power, which a serious contemplation of a starry sky is calculated to convey, all the kingdoms of this world would sink into comparative insignificance, and all their pomp and splendor appear as empty as the bubbles of the deep. It is amazing that *Christians*, in particular, should, in so many instances, be found overlooking such striking displays of Divine perfection as the firmament opens to our view, as if the most august works of the Creator, and the most striking demonstration of his "eternal power and godhead," were unworthy of their regard; while we are commanded, in Scripture, to "lift up our eyes on high, and consider Him who hath created these orbs, who bringeth forth their hosts by number," and who guides them in all their motions "by the greatness of his strength." "The heavens," says the Psalmist, "declare the glory of the Lord, and the firmament showeth his handiwork." Though these luminaries "have no speech nor language," though "their voice is not heard" in articulate sounds, yet, as they move along in *silent* grandeur, they declare to every reflecting beholder that "the hand that made them is Divine."

One great cause of this indifference and inattention is to be found in the want of those habits of observation and reflection which ought to be formed in early life by the instructions imparted in the family circle and at public seminaries. Children, at a very early age, are endowed with the principle of curiosity, and manifest an eager desire to become acquainted with the properties and movements of the various objects which surround them; but their curiosity is, in most instances, improperly directed; they are seldom taught to make a right use of their senses; and when they make inquiries in reference to the appearances of nature, their curiosity is too frequently repressed, until, at length, habits of inattention and indifference take possession of their minds. A celebrated author represents his pupil as expressing himself in the following manner:—"I shall freely tell you the things which frequently occur to my mind, and often perplex my

thoughts. I see the heavens over my head, and tread on the earth with my feet; but I am at a loss what to think of that *mighty concave* above me, or even of this very earth I walk upon. I often think whether the earth may not stretch out in breadth to immensity, so as, if one was to travel it over, one should never be able to get to the *end* of the earth, but always find room to continue the journey; nor can I satisfy myself as to the depth of the earth, whether it has any bottom; and, if so, what it can be that is below the earth. As to the heaven, I need say nothing; every change that happens, and every object seen there, perplex me with doubts and fruitless guesses. I often wonder how the sun moves over so large a space every day, and yet seems not to stir out of his place. I would know where he goes beyond the mountains in the evening; what becomes of him in the night-time; whether he makes his way through the thickness of the earth, or the depth of the sea, and so always shows himself again from the east next morning. It seems strange that, being so small a body as he is, he should still be seen everywhere, and still of the same bigness. The various nature of the *moon* seems yet more perplexing; to-night, perhaps, you can scarce discern her; but, in a few days, she becomes larger than the body of the sun itself. In a little time after, she decays, and, at last, wears quite away; yet she recovers again. In a word, she is never the same, and yet still becoming what she was before. What means that multitude of stars scattered over the face of the whole sky, whose number is so great that it is become proverbial? There are other things I want to be informed of, but these are the main difficulties which exercise my thoughts, and perplex my mind with endless doubting."

Were the young, or any other class of persons, led to such reflections as these, and were their doubts and inquiries resolved, so far as our knowledge extends, we should have a hundred intelligent observers of the phenomena of the universe for one that is found in the present state of society. But, instead of answering their inquiries and gratifying their natural curiosity, we not unfrequently tell them that they are troublesome with their idle questions; that they ought to mind their grammar and parts of speech, and not meddle with philosophical matters until they be many years older; that such subjects cannot be understood until they become men; and that they must be content to remain in ignorance for ten or twelve years to come. Thus we frequently display our own ignorance and inattention, and thus we repress the natural desire for knowledge in the young, until they become habituated to ignorance, and until the uneasy sense arising from curiosity and unsatisfied desire has lost its edge, and a desire for sensual or vicious pleasure usurps its place. I recollect, when a boy of about seven or eight years of age, frequently musing on such subjects as those to which we have now alluded. I sometimes looked out from a window, in the daytime, with fixed attention, on a pure azure sky, and sometimes stretched myself on my back on a meadow, or in a garden, and looked up to the zenith to contemplate the blue ethereal. On such occasions a variety of strange ideas sometimes passed through my mind. I wondered how far the blue vault of heaven might extend; whether it was a solid transparent arch, or empty space; what would be seen could I transport myself to the highest point I perceived; and what display the Almighty made of himself in those regions so far removed from mortal view. I asked myself

whether the heavens might be bounded on all sides by a solid wall; how far this wall might extend in thickness; or whether there was nothing but empty space, suppose we could fly forever in any direction. I then entered into a train of inquiries as to what would have been the consequences had neither heaven nor earth been made, and had God alone existed in the boundless void. Why was the world created? What necessity was there why God himself should exist? And why was not all one vast blank, devoid of matter and intelligence? My thoughts ran into wild confusion; they were overwhelming, and they became even oppressive and painful, so as to induce me to put a check to them, and to hasten to my playful associates and amusements. But although my relatives were more intelligent than many of their neighbors, I never thought of broaching such ideas, or of making any inquiries of them respecting the objects which had perplexed my thoughts; and, even if I had, it is not likely I should have received much satisfaction. Such views and reflections are, perhaps, not uncommon in the case of thousands of young people. I mention these things to show that the youthful mind, in consequence of the innate desire of knowledge with which it is endowed, is often in a state peculiarly adapted for receiving instruction on many important subjects, and for becoming an intelligent observer of the economy of nature, were it not that our methods of instruction hitherto, both in public and in private, instead of gratifying juvenile curiosity, have frequently tended to counteract the natural aspirations of the opening mind.

But, leaving such reflections and digressions, let us now take a general view of the motions of and phenomena of the nocturnal heavens.

Let us suppose ourselves under the open canopy of heaven in a clear night, at six o'clock in the evening, about the first of November. Fix upon this period, because the *Pleiades*, or seven stars, which are known to every one, are then visible during the whole night, and because, at this season of the year, the most brilliant fixed stars, and the more remarkable constellations, are above the horizon in the evening. Turning our eyes, in the first place, toward the *easterly* quarter of the heavens, we shall see the seven stars just risen above the horizon, in a direction about half way between the east and the north-east points, or east-north-east. North-west from the seven stars, at the distance of thirty degrees, a very bright star, named *Capella*, may be perceived at an elevation of about eighteen degrees above the horizon. Directing our view toward the south, we shall perceive a pretty bright star, with a small star on the north and another on the south of it, which has just passed the meridian. This star is called *Altair*, and belongs to the constellation *Aquila*.—It is nearly south, at an elevation of forty-six degrees, or about half-way between the horizon and the zenith. About thirty-three degrees north from *Altair*, and a little farther to the west, is the brilliant star *Lyra*, belonging to the *Harp*. Looking to the west, a bright star, named *Arcturus*, will be seen about fifteen degrees above the horizon, a very little to the north of the western point. Turning our eyes in a northerly direction, the constellation *Ursa Major*, or the Great Bear, presents itself to view. This cluster of stars is sometimes distinguished by the name of the *Plow*, or *Charles's Wain*, and is known to almost every observer. The relative positions of the prominent stars it contains are represented in the following figure. At the time of the evening



now supposed, it appears a little to the westward of the northern point of the heavens, the two eastern stars of the square being about eighteen degrees west from that point. These two stars, the uppermost of which is named *Dubhe*, and the lower one *Merak*, are generally distinguished by the name of the *Pointers*, because they *point*, or direct our eye toward the pole-star.

The seven stars in the lower part of the figure are the prominent stars which constitute the tail and the body of the Great Bear. The first of these, reckoning from the left, is termed *Benetnasch*, the second *Mizar*, the third *Alioth*, the fourth *Megrez*, immediately below which is *Phad*. The other two stars to the right are the *Pointers*, alluded to above. If a line connecting these two stars be considered as prolonged upward to a considerable distance until it meet the first bright star, it directs us to the *pole-star*, which is the one nearest to the pole, and which, to a common observer, never seems to shift its position. The uppermost star in the figure toward the right hand represents the pole-star in its relative distance and position to the Great Bear. The distance between the two pointers, *Dubhe* and *Merak*, is about five degrees; and the distance between *Dubhe*, the uppermost of the pointers, and the pole-star, is about twenty-nine degrees; so that the space between *Dubhe* and the pole-star is nearly six times the distance between the two pointers. By attending to these circumstances, the distance between any two stars, when expressed in degrees, may be nearly ascertained by the eye. The six small stars in the upper part of the figure represent the constellation *Ursa Minor*, or the Lesser Bear, of which the pole-star forms the tip of the tail.—They resemble the configuration of the stars in

Fig. 1.

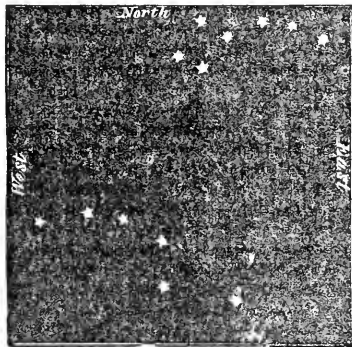

the Great Bear, only they are on a smaller scale, and in a reversed position.\*

Having now fixed on certain stars or points in the heavens as they appear about six in the evening, and marked their relative positions, let us take another view of the celestial vault as it appears about ten o'clock the same evening, or the first clear evening afterward. We shall then find that the seven stars have risen to a considerable

\*In these observations, the observer is supposed to be placed nearly in 52° north latitude, which is nearly the latitude of London. Those who reside in latitudes between 40° and 45°, as the inhabitants of Philadelphia, New York, Hartford, Boston, Montreal, Madrid, Rome, etc., would require to postpone their observations until a little after half-past six in the evening, and to make a small allowance for the elevations, above stated, of certain stars above the horizon. In most other respects, the appearance of the heavens, to the inhabitants of such places, will be the same as here described.

elevation, and are nearly half way between the eastern horizon and the south; that the *Bull's-eye*, a bright ruddy star, which was before invisible, is now seen a little to the eastward of the Pleiades; and that bright constellation *Orion*, which in the former observation was below the horizon, is now distinctly visible in the east and south-east; and the star *Capella* midway between the horizon and the zenith. The stars *Altair* and *Lyra*, which were before nearly south, have descended more than half-way toward the western horizon.—The star *Arcturus* is no longer visible, having sunk beneath the horizon; and many stars in the eastern quarter of the heavens, which were formerly unseen, now make their appearance at different elevations. The stars of the Great Bear, particularly the two pointers, which were formerly to the west of the north point, have now passed to the east of it. At twelve o'clock, midnight, their position may be thus represented.

Fig. 2.

North.

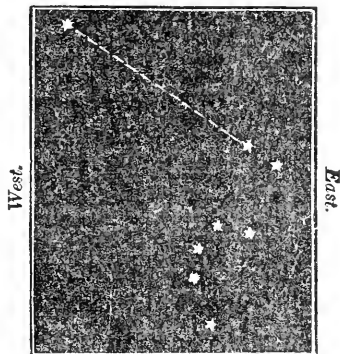

The pointers now appear considerably to the eastward of the north point, and considerably more elevated than before, while the stars in the tail appear much lower. About three o'clock next morning the pointers will appear nearly due east from the pole-star, and at the same elevation above the horizon; and the other stars in that constellation will be seen hanging, as it were, nearly perpendicularly below them. At this hour the Pleiades, or seven stars, will appear to have moved twenty-five degrees past the meridian to the west, and the brilliant constellation *Orion* will be seen nearly due south. The bright star *Capella* now appears nearly in the zenith, or point directly over our heads; *Lyra* is in the horizon, nearly due north, and *Altair* has descended below the western horizon. At six in the morning, the seven stars will be seen in the west, only a short distance above the horizon; and all the other stars to the eastward of them will be found to have made a considerable progress toward the west.—At this hour the stars of the Great Bear will appear near the upper part of the heavens, and the pointers not far from the zenith. Their position at this time is shown in the following figure.

Here the pointers appear elevated a great way above the pole-star, whereas, in the observation at six in the evening, the whole constellation appeared far below it. At eight in the morning, the whole of the constellation would be seen nearly overhead, were the stars then visible; at twelve, noon, it would appear toward the west, at a considerable elevation; and at six in the evening, it would again return to its former position, as noted

Fig. 3.

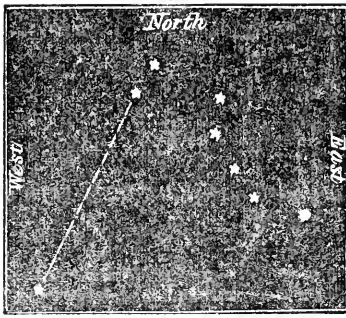

in our first observation. The following figure represents the position of *Ursa Minor*, or the Lesser Bear, at four different periods during twenty-four hours.

Fig. 4.

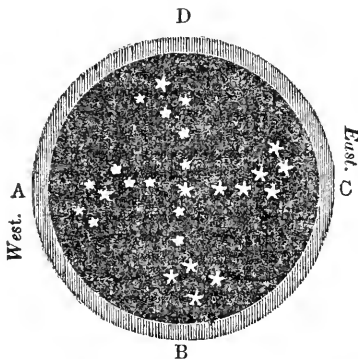

At six in the evening, about the beginning of November, *Ursa Minor* will be nearly in the position represented on the left at *A*, nearly straight west from the pole-star, which appears in the center. Six hours afterward, or at twelve, midnight, it will appear below the pole, in the position marked *B*; at six next morning, it will appear opposite to its first position, as represented on the right at *C*; at twelve, noon, it will appear above the pole, as represented at *D*; but in this position it cannot be seen in November, or during the winter months, as the stars at that time of the day are eclipsed by the light of the sun. At six in the evening it again returns to its former position. Such are the general appearance and apparent motions of all the stars in the northern hemisphere, within fifty-two degrees of the pole, to a spectator situated in  $52^{\circ}$  of north latitude. They all appear to perform a circuit, in the course of twenty-four hours, around a point which is the center of their motion, near to which is the pole-star. All the stars within this range never set, but appear to describe complete circles, of different dimensions, around the pole and above the horizon. When they are in the lower part of their course, or beneath the pole, they appear to move from west to east; but when in the higher part of their course, their apparent motion is from east to west; and all their circuits are completed in exactly the same period of time, namely, twenty-three hours, fifty-six minutes, and four seconds.

Let us now consider the appearances which present themselves in the other quarters of the heavens. If we turn our eyes a little to the left

of the south, near to that point of the compass called south-south-east, and observe a star near the horizon, such as the star *Fomalhaut*, in the Southern Fish, it will appear to rise to a very small altitude when it comes to the meridian, only about six degrees, and in about five hours it will set near the point south-south-west, having described a very small arc of a circle above the horizon. If we direct our attention to the south-east, and observe any bright star, such as *Sirius*, or the Dog-star, in the horizon, it will make a larger circuit over the southern sky, and will remain about nine hours above the horizon before it sets in the south-west. If we look due east, and see a star, such as *Procyon* in the constellation of the Lesser Dog, rising, it will remain about twelve hours above the horizon, and will set in the west. If we look to the north-east, and perceive any stars, such as *Castor* and *Pollux*, beginning to appear, they will make a large circuit round the heavens, such as the sun describes in the month of June, and, after the period of about eighteen hours, will set in the north-west.

Such are the general appearances and the apparent motions of the heavens which present themselves when viewed from our northern latitude. Were we to take our station near the Gulf of Guinea, in the island of Sumatra, or Borneo, in the Gallipago Isles, in the city of Quito, in South America, or on any other point of the globe near the equator, the motions of the stars would appear somewhat different. The pole-star, instead of being at a high elevation, as in our latitude, would be in the horizon. All the stars would appear to rise and set, and the time of their continuance above the horizon would be precisely the same. The stars which rise in the east would ascend to the zenith, and pass directly overhead, in the course of six hours; and in another six hours they would descend to the horizon, and set in the western point. The stars near the northern and southern points would appear to describe small semicircles above the horizon during the same time, and their motion would appear much slower. The Great Bear, which never sets in our latitude, would be above the horizon only during the one-half of its circuit. Many stars and constellations would appear in the southern quarter of the sky which we never see in our latitude. Every star would be found to remain exactly twelve hours above and twelve hours below the horizon, and all the visible stars in the firmament might, from such a position be perceived in the course of a year. Were we to take our station in the southern hemisphere, in Valdivia, Botany Bay, or Van Dieman's Land, the heavens would present a different aspect from any of those we have yet contemplated. The north pole-star, the Great Bear, and other neighboring constellations, would never appear above the horizon. Many of the stars which we now see in the south would appear in the north. The south pole would appear elevated about forty degrees above the horizon, and various clusters of stars would be seen revolving round it, as the Great Bear and other constellations do around the north pole. In fine, could we take our station at ninety degrees of north latitude, or, in other words, at the north pole of the world, we should just see one-half of the stars of heaven, and no portion of the other half would ever be visible. These stars would appear neither to rise nor set, nor yet to stand still. They would appear to move round the whole heavens, in circles parallel to the horizon, every twenty-four hours; and on every clear evening, all the stars that are ever visible in that

hemisphere may be seen. The stars, however, that appear in a certain direction at any particular hour, will appear at the same elevation in the opposite direction, twelve hours afterward; and during nearly six months no stars will be seen in the sky.

The apparent motion of the heavens may at any time be perceived by fixing on any star that appears nearly in a line with a tree, a spire, or any other fixed object, and in the course of a few minutes its motion will be perceptible; or, fix a common telescope upon a pedestal, and direct it to any star, and in three or four minutes it will be seen to have passed out of the field of view. In the description now given, I have spoken of the *pole-star* as if it were actually the pole, or the most northerly point of the heavens. But it may be proper to state, that though it is the nearest large star to that point, it is not actually in the pole; it is somewhat more than a degree and a half from the polar point, and revolves around that point, in a small circle, every twenty-four hours. This motion may be perceived by directing a telescope of a moderate magnifying power to this star, and fixing it in that position, when, in the course of an hour or two, it will be found to have moved beyond the field of view.

All the observations above stated (excepting those supposed to have been made at the equator, and in southern latitudes) may be accomplished in the course of two or three evenings, without incurring the loss of a couple of hours; for each observation may be made in the space of five or ten minutes. Every inhabitant of the globe has an opportunity, if he choose, of observing the aspect of the heavens in the manner now described, excepting, perhaps, those who live in dark and narrow lanes, in large cities, where the sky is scarcely visible; the most unnatural situations in which human beings can be placed, and which ought no longer to remain as the abodes of men. And the man who will not give himself the trouble of making such observations on the starry heavens, deserves to remain in ignorance of the most sublime operations of the Creator.

Let us now consider what is the conclusion we ought to deduce from our observations respecting the apparent motions of the heavens. All the phenomena which we have described, when duly considered and compared together, conspire to show that the *whole celestial vault performs an apparent revolution round the earth*, carrying, as it were, all the stars along with it, in the space of twenty-four hours. This may be plainly demonstrated by means of a celestial globe, on which all the visible stars are depicted. When the north pole is elevated fifty-two degrees above the northern horizon, and the globe turned round on its axis, all the variety of phenomena formerly described may be clearly perceived.

Here, then, we have presented to view a scene the most magnificent and sublime. All the bright luminaries of the firmament revolving in silent grandeur around our world; not only the stars visible to the unassisted eye, but all the ten thousands and millions of stars which the telescope has enabled us to descry in every region of the heavens, for they all seem to partake of the same general motion. If we could suppose this motion to be *real*, it would convey to the mind the most magnificent and impressive idea which could possibly be formed of the incomprehensible energies of Omnipotence. For here we have presented to view, not only ten thousand times ten thousands of immense globes, far superior to the whole earth in magnitude, but the greater part of them carried

round in their revolutions with a velocity that baffles the power of the most capacious mind to conceive. In this case, there would be millions of those vast luminaries, which behoved to move at the rate of several thousands of millions of miles in the space of a second of time. For in proportion to the distances of any of these bodies would be the rapidity of their motions. The nearest star would move more than fourteen hundred millions of miles during the time in which the pendulum of a clock moves from one side to another; but there are thousands of stars visible through our telescopes at least a hundred times more distant, and whose distance cannot be less than 2,000,000,000,000,000, or two thousand billions of miles. This forms the radius, or half diameter of a circle, whose circumference is about 12,500,000,000,000,000, or twelve thousand five hundred billions of miles. Around this circumference, therefore, the star behoved to move every day. In a sidereal day of twenty-three hours, fifty-six minutes, and four seconds, there are 86,164 seconds. Divide the number of miles in the circumference by the number of seconds in a day, and the quotient will be somewhat more than 145,000,000,000, or one hundred and forty-five thousand millions, which is the number of miles that such a star would move in the space of a second, or during the pulsation of an artery, were the celestial vault to be considered as really in motion; a rate of motion more than a hundred thousand millions of times greater than that of a cannon ball, and seven hundred thousand times more rapid than the motion of light itself, which is considered the swiftest motion in nature.

The idea of such astonishing velocities completely overpowers the human imagination, and is absolutely inconceivable. We perceive no objects or motions connected with our globe that can assist our imagination in forming any definite conceptions on this subject. The swiftest impulse that was ever given to a cannon ball, or any other projectile, sinks into nothing in the comparison. Were we transported to the planet Saturn, and placed on its equatorial regions, we should behold a stupendous arch, thirty thousand miles in breadth, and more than six hundred thousand miles in circumference, revolving around us every ten hours, at the rate of a thousand miles in a minute, and sixty thousand miles every hour.—But even this astonishingly rapid motion would afford us little assistance in forming our conceptions, as it bears no comparison with the motions to which we have now adverted. It becomes those persons, therefore, who refuse to admit the motion of the earth, to consider, and to ponder with attention, the only other alternative which *must* be admitted, namely, that all the bodies of the firmament move round the earth every day with such amazing velocities as have now been stated. If it appear wonderful that this globe of the land and water, with all its mighty cities and vast population, moves round its axis every day at the rate of a thousand miles an hour, how much more wonderful, and passing all comprehension, that myriads of huge globes should move round the earth in the same time with such inconceivable rapidity. If we reject the motion of the earth because it is incomprehensible and contrary to all our preconceived notions, we must, on the same ground, likewise reject the motion of the heavens, which is far more difficult to be conceived, and consequently fall into downright skepticism, and reject even the evidences of our senses as to what appears in the economy of nature. Such views and considerations, however, teach us that, in

whatever point of view we contemplate the works of the Almighty, particularly the scenery of the heavens, the mind is irresistibly inspired with sentiments of admiration and wonder. To the vulgar eye as well as to the philosophic, "the heavens declare the glory of God." Their harmony and order evince his wisdom and intelligence; and the numerous bodies they contain, and the astonishing motions they exhibit, on whatever hypothesis they are contemplated, demonstrate both to the savage and the sage the existence of a power which no created being can control.

"View the amazing canopy!  
The wide, the wonderful expanse!  
Let each bold infidel agree  
That God is there, unknown to chance."

We cannot, however, admit, in consistency with the dictates of enlightened reason, that the apparent diurnal movements of the stars are the *real* motions with which these bodies are impelled.—For, in the first place, *such motions are altogether unnecessary* to produce the effect intended, namely, the alternate succession of day and night with respect to our globe; and we know that the Almighty does nothing in vain, but employs the most simple means to accomplish the most astonishing and important ends. The succession of day and night can be accomplished by a simple rotation of the earth from west to east every twenty-four hours, which will completely account for the apparent motion of the heavens, in the same time, from east to west. This we find to be the case with Jupiter and Saturn, which are a thousand times larger than the earth, as well as with the other planets, which have a rotation round their axes, some in ten hours, some in twenty-three, and some in ten hours and a half; and consequently, from the surfaces of these bodies the heavens *will appear* to revolve around them in another direction from what they do to us, and, in certain instances, with a much greater degree of velocity. We must therefore conclude that our motion every day toward the east causes the heavens to appear as if they moved toward the west; just as the trees and houses on the side of a narrow river appear to move to the west when we are sailing down its current in a steamboat toward the east.

2. *Because it is impossible to conceive that so many bodies of different magnitudes, and at different distances from the earth, could all have the same period of diurnal revolution.* The sun is four hundred times farther from us than the moon, and is sixty millions of times larger. Saturn and Herschel are still further from the earth; the comets are of different sizes, and traverse the heavens in all directions and at different distances; the fixed stars are evidently placed at different distances from the earth and from each other; yet all these bodies have exactly the same period of revolution, even to a single moment, if the heavens revolve around the earth, and that, too, notwithstanding the other motions, in various directions, which many of them perform. It is, therefore, much more natural and reasonable to suppose that the earth revolves around its axis, since this circumstance solves all the phenomena and removes every difficulty.

3. *Because such a rate of motion in the heavenly bodies, if it could be supposed to exist, would soon shatter them to atoms.* Were a ball of wood to be projected from a cannon at the rate of a thousand miles an hour, in a few moments it would be reduced to splinters; and hence the forge and other soft substances projected from a musket or a piece of ordnance are instantly torn to pieces. What,

then, might be supposed to be the consequence, were a body impelled through the regions of space with a velocity of a hundred and forty thousand millions of miles in a moment of time? It would most assuredly reduce to atoms the most compact bodies in the universe, although they were composed of substances harder than adamant. But as the fixed stars appear to be bodies of a nature somewhat similar to the sun, and as the sun is much less dense than the earth, and only a little denser than water, it is evident that they could not withstand such a rapidity of motion, which would instantly shatter their constitution, and dissipate every portion of their substance through the voids of space.

4. *Because there is no known instance in the universe (if that to which we are now adverting be excepted) of a larger body revolving around a smaller.* The planet Jupiter does not revolve around his satellites, which are a thousand times less than that ponderous globe, but they all revolve around him; nor does the earth, which is fifty times larger than the moon, revolve around that nocturnal luminary, but she regularly revolves about the earth, as the more immediate center of her motion. The sun does not perform his revolution around Venus or Mercury, but these planets, which are small, compared with that mighty orb, continually revolve about him as the center of their motions. Neither on earth nor in the heavens is there an instance to be found contrary to this law, which appears to pervade the whole system of universal nature; but if the diurnal revolution of the stars is to be considered as their proper motion, then the whole universe, with all the myriads of huge globes it contains, is to be considered as daily revolving around an inconsiderable ball, which, when compared with these luminaries, is only as an atom to the sun, or as the smallest particle of vapor to the vast ocean.

5. *The apparent motion of the heavens cannot be admitted as real, because it would confound all our ideas of the intelligence of the Deity.* While it tended to exalt our conceptions of his omnipotence to the highest pitch, it would convey to us a most unworthy and distorted idea of his wisdom. Wisdom is that perfection of an intelligent agent which enables him to proportionate one thing to another, and to devise the most proper means in order to accomplish important ends. We infer that an artist is a wise man from the nature of his workmanship, and the methods he employs to accomplish his purposes. We should reckon that person foolish in the extreme who should construct, at a great expense, a huge and clumsy piece of machinery for carrying round a grate, and the wall of a house to which it is attached, for the purpose of roasting a small fowl placed in the center of its motion, instead of making the fowl turn round its different sides to the fire. We should consider it as the most preposterous project that was ever devised were a community to attempt, by machinery, to make a town and its harbor move forward to meet every boat and small vessel that entered the river on which it was situated, instead of allowing such vehicles to move onward as they do at present. But none of these schemes would be half so preposterous as to suppose that the vast universe moves daily round an inconsiderable ball, when no end is accomplished by such a revolution but what may be effected in the most simple manner. Such a device, therefore, cannot be any part of the arrangements of Infinite Wisdom. It would tend to lessen our ideas of the intelligence of that adorable Being who is "wonderful in counsel and excellent in working."

who "established the world by his wisdom, and stretched out the heavens by his understanding," and whose wisdom as far exceeds that of man as the "heaven in its high surpasses the earth."—This argument alone I consider as demonstrative of the position we are now attempting to support.

The above are a few arguments which, when properly weighed, ought to carry conviction to the mind of every rational inquirer, that the general motion which appears in the starry heavens is not real, but is caused by the rotation of the earth round its axis every day, by which we and all the inhabitants of the globe are carried round in a regular and uniform motion from west to east. When this conclusion is admitted, it removes every difficulty and every disproportion which at first appeared in the motions and arrangements of the celestial orbs, and reduces the system of the universe to a scene of beauty, harmony and order worthy of the infinite wisdom of Him who formed the plan of the mighty fabric, and who settled "the ordinances of heaven." Instead, then, of remaining in a state of absolute rest, as we are at first apt to imagine, we are transported every moment toward the east with a motion ten times more rapid than has ever been effected by steam-carriages or air-balloons. It is true, we do not feel this motion, because it is smooth and uniform, and is never interrupted. The earth is carried forward in its course, not like a ship in the midst of a tempestuous ocean, but through a smooth ethereal sea, where all is calm and serene, and where no commotions to disturb its motion ever arise. Carried along with a velocity which is common to everything around us, we are in a state somewhat similar to that of a person in a ship which is sailing with rapidity in a smooth current; he feels no motion except when a large wave or other body happens to dash against the vessel; he fancies himself at rest, while the shore, the buildings, and the hills appear to him to move; but the smallness of the vessel, compared with the largeness of the objects which seem to move, convinces him that the motion is connected with the ship in which he sails: and on similar principles we infer that the apparent motion of the heavens is caused by the real motion of the earth, which carries us along with it as a ship carries its passengers along the sea. With regard to motion, it may be observed, that, strictly speaking, we do not perceive any motion either in the earth or in the heavens. When we look at a star with the utmost steadiness, we perceive no motion, although we keep our eye fixed upon it for a few minutes; but, if we mark the position of the star with regard to a tree or a chimney top, and, after an hour or two, view the star from the same station, we shall find that it then appears in a different direction. Hence we infer that motion has taken place; but whether the motion be in the star or in the persons who have been observing it, remains still to be determined. We perceive no motion in the star any more than we feel the motion of the earth. All that we perceive is, that the two objects have changed their relative positions; and, therefore, the body that is really in motion must be determined by such considerations as we have stated above.

Beside the apparent diurnal revolution of the heavens, there is another apparent motion which requires to be considered. It is well known to every one who has paid the least attention to this subject, that we do not perceive the same clusters of stars at every season of the year. If, for example, we take a view of the starry heavens on the first of October, at ten o'clock in the evening,

and again, at the same hour, on the first of April, we shall find that the clusters of stars in the southern parts of the heavens are, at the latter period, altogether different from those which appeared in the former; and those which are in the neighborhood of the pole will appear in a different position in April from what they did at the same hour in the month of October. The square of the *Great Bear*, for example, will appear immediately below the pole-star in October; whereas in April it will appear as far above it, and near to the zenith. In the former case, the two stars called the *Pointers* will point upward to the pole, in the latter case they will point downward. In October this constellation will appear nearly in the position represented in fig. 1 (p. 13); in April it will appear nearly as represented in fig. 3 (p. 13). These variations in the appearance of the stars lead us to conclude that there is an *apparent annual motion* in these luminaries. This motion may be observed, if we take notice, for a few days or weeks, of those stars which are situated near the path of the sun. When we see a bright star near the western horizon, a little elevated above the place where the sun went down, if we continue our observation we shall find that every day it appears less elevated at the same hour, and seems to be gradually approaching to the point of the heavens in which the sun is situated, until, in the course of a week or two, it ceases to be visible, being overpowered by the superior brightness of the sun. In the course of a month or two the same star which disappeared in the west will be seen rising some time before the sun in the east, having passed from the eastern side of the sun to a distance considerably westward of him. The stars in the western quarter of the heavens which appeared more elevated will be found gradually to approximate to the sun, until they likewise disappear; and in this manner all the stars of heaven seem to have a revolution, distinct from their diurnal, from east to west, which is accomplished in the course of a year.

The different positions of the *Pleiades*, or seven stars, at different seasons of the year, will afford every observer an opportunity of perceiving this motion. About the middle of September these stars will be seen, about eight o'clock in the evening, a little to the south of the north-east point of the horizon; about the middle of January, at the same hour, they will be seen on the meridian, or due south; on the first of March they will be seen half-way between the zenith and the western horizon; about the middle of April they will appear very near the horizon; soon after which they will be overpowered by the solar rays, and will remain invisible for nearly two months, after which they will re-appear in the east, early in the morning, before the rising sun.

This annual motion of the stars evidently indicates that the sun has an *apparent* motion every day from west to east, contrary to his apparent diurnal motion, which is from east to west. This apparent motion is at the rate of nearly a *degree* every day, a space nearly equal to twice the sun's apparent diameter. In this way the sun appears to describe a circle around the whole heavens, from west to east, in the course of a year. This apparent motion of the sun is caused by the *annual* revolution of the earth around the sun as the center of its motion, which completely accounts for all the apparent movements in the sun and stars to which we have now adverted. If we place a candle upon a table in the midst of a room, and walk round it in a circle, and, as we proceed, mark the different parts of the opposite walls with

which the candle appears coincident, when we have completed our circle the candle will appear to have made a revolution round the room. If the walls be conceived to represent the starry heavens, and the candle the sun, it will convey a rude idea of the apparent motion of the sun, and the different clusters of stars which appear at different seasons of the year in consequence of the annual motion of the earth. But this subject will be more particularly explained in the sequel.

From what we have now stated in relation to the apparent motions of the heavens, we are necessarily led to conceive of the earth as a body, placed, as it were, in the midst of infinite space, and surrounded in every direction, above, below, on the right hand and on the left, with the luminaries of heaven, which display their radiance from every quarter at immeasurable distances; and that its annual and diurnal motions account for all the movements which appear in the celestial sphere. Hence it is a necessary conclusion, that we are surrounded at all times with a host of stars, in the *day-time* as well as in the night, although they are then imperceptible. The reason why they are invisible during the day is obviously that their fainter light is overpowered by the more vivid splendor of the sun and the reflective power of the atmosphere. But although they are then imperceptible to the unassisted eye, they can be distinctly perceived, not only in the mornings and evenings, but even at noonday, while the sun is shining bright, by means of telescopes adapted to an equatorial motion; and in this way almost every star visible to the naked eye at night can be pointed out, even amid the effulgence of day, when it is within the boundary of our hemisphere. When the stars which appear in our sky at night have, in consequence of the rotation of the earth, passed from our view, in about twelve hours afterward they will make their appearance nearly in the same manner to those who live on the opposite side of the globe; and when they have cheered the inhabitants of those places with their radiance, they will again return to adorn our nocturnal sky.

On the whole, *the starry heavens present, even to the vulgar eye, a scene of grandeur and magnificence.* We know not the particular destination of each of those luminous globes which emit their radiance to us from afar, or the specific ends it is intended to subservise in the station which it occupies, though we cannot doubt that all of them answer purposes in the Creator's plan worthy of his perfections and of their magnitude and grandeur; but we are certain that they have, at least, a remote relation to man, as well as to other beings far removed from us, in the decorations they throw around his earthly mansion. They serve as a glorious ceiling to his habitation. Like so many thousand sparkling lusters, they are hung up in the magnificent canopy which covers his abode. He perceives them shining and glittering on every hand, and the dark azure which surrounds them contributes to augment their splendor. The variety of luster which appears in every star, from those of the sixth magnitude to those of the first,

and the multifarious figures of the different constellations, present a scene as diversified as it is brilliant. What are all the decorations of a Vauxhall Garden, with its thousands of variegated lamps, compared with ten thousands of suns, diffusing their beams over our habitation from regions of space immeasurably distant? A mere gewgaw in comparison; and yet there are thousands who eagerly flock to those gaudy shows who have never spent an hour in contemplating the glories

of the firmament, which may be beheld "without money and without price." That man who has never looked up with serious attention to the motions and arrangements of the heavenly orbs must be inspired with but a slender degree of reverence for the Almighty Creator, and devoid of taste for enjoying the beautiful and the sublime.

The stars not only adorn the roof of our sublunary mansion, but they are also, in many respects, *useful* to man. Their influences are placid and gentle. Their rays, being dispersed through spaces so vast and immense, are entirely destitute of heat by the time they arrive at our abode; so that we enjoy the view of a more numerous assemblage of luminous globes without any danger of their destroying the coolness of the night or the quiet of our repose. They serve to guide the traveler both by sea and land; they direct the navigator in tracing his course from one continent to another through the pathless ocean. They serve "for signs and for seasons, and for days and years." They direct the labors of the husbandman, and determine the return and conclusion of the season. They serve as a magnificent "timepiece" to determine the true length of the day and of the year, and to mark with accuracy all their subordinate divisions. They assist us in our commerce, and in endeavoring to propagate religion among the nations, by showing us our path to every region of the earth. They have enabled us to measure the circumference of the globe, to ascertain the *density* of the materials of which it is composed, and to determine the exact position of all places upon its surface. They cheer the long nights of several months in the polar regions, which would otherwise be overspread with impenetrable darkness. Above all, they open a prospect into the regions of other worlds, and tend to amplify our views of that Almighty Being who brought them into existence by his power, and "whose kingdom ruleth over all." In these arrangements of the stars in reference to our globe, the Divine wisdom and goodness may be clearly perceived. We enjoy all the advantages to which we have alluded as much as if the stars had been created solely for the use of our world, while, at the same time, they serve to diversify the nocturnal sky of other planets, and to diffuse their light and influence over ten thousands of other worlds with which they are more immediately connected; so that, in this respect, as well as in every other, the Almighty produces the most sublime and diversified effects by means the most simple and economical, and renders every part of the universe subservient to another, and to the good of the whole.

Before proceeding further, it may be expedient to explain the *measures* by which astronomers estimate the apparent distances between any two points of the heavens. Every circle is supposed to be divided into 360 equal parts. A circle which surrounds the concavity of the heavens, as that which surrounds an artificial globe, is divided into the same number of parts. The number 360 is entirely arbitrary, and any other number, had mathematicians chosen, might have been fixed upon; and hence the French, in their measures of the circle, divide it into 400 equal parts or degrees; each degree into 100 minutes, and each minute into 100 seconds. The reason why the number 360 appears to have been selected, is, that this number may be divided into halves, quarters, and eighths, without a fraction; and, perhaps, because the year was, in former times, supposed to contain about 360 days. Each degree is divided

into sixty minutes, each minute into sixty seconds, each second into sixty thirds, &c. Degrees are marked thus, °; minute, ′; seconds, ″; thirds, ‴. Thus the obliquity of the ecliptic for January 1st, 1836, was twenty-three degrees, twenty-seven minutes, forty-two seconds, which are thus expressed,  $23^{\circ} 27' 42''$ .

It may not be improper to remark, that when we state the number of degrees between two objects, either on the earth or in the heavens, it is not intended to express the *real* distance, but only the *relative* or *apparent* distance of the objects. Thus, when we say that two places on the earth, which lie directly north and south of each other, are twenty degrees distant, it does not convey an idea of the *actual distance* of these places from each other, but only what proportion of the earth's circumference intervenes between them. If, however, we know the number of yards or miles contained in that circumference, or in a single degree of it, we can then find the actual distance, by multiplying the number of degrees by the number of miles in a degree. But this supposes that the extent of a degree on the earth's surface has been measured, and the number of yards or miles it contains ascertained. In like manner, when we say that two stars in the heavens are fifteen degrees from each other, this merely expresses their relative position, or what portion of a great circle of the celestial sphere intervenes between them, but determines nothing as to their real distance, which is far surpassing our comprehension. The real magnitude of objects or spaces in the heavens depends upon their distance. Thus, the apparent breadth or diameter of the moon is about half a degree, or nearly thirty-two minutes, and that of the sun nearly the same; but as the moon is much nearer to us than the sun, a *minute of a degree* on her surface is equal only to about seventy miles, while a minute on the sun's surface is equal to more than 28,000 miles, which is four hundred times greater. The greatest apparent diameter of Saturn is twenty seconds, or one-third of a minute; the greatest diameter of Venus is fifty-eight seconds, or nearly a minute; but as Saturn is much farther from us than Venus, his real diameter is 79,000 miles, while that of Venus is only 7,700. Before

the real diameter of any object in the heavens can be determined, its distance must be first ascertained.

Those who have never been in the practice of applying angular instruments to the heavens may acquire a tolerably correct idea of the extent of space which is expressed by any number of degrees by considering that the apparent diameters of the sun and moon are about *half a degree*; that the distance between the two pointers in the Great Bear is about five degrees; that the distance between the pole-star and the nearest pointer is twenty-nine degrees; that the distance between the *Pleiades* and the ruddy star *Aldebaran*, which lies to the eastward of these stars, is fourteen degrees; that the distance between *Castor* and *Pollux* is five degrees; and the distance between *Bellatrix* and *Betelgeuse*, the stars in the right and left shoulder of *Orion*, is eight degrees. Perhaps the most definite measure for a common observer is that which is to be found in the three stars in a straight line which form the *belt* of *Orion*, which are known to every one, and which are distinguished in England by the name of the *Three Kings*, or the *Ell* and *Yard*, and in Scotland by "*The Lady's Elwand*." The line which unites these three stars measures exactly three degrees, and, consequently, there is just one and a half degree between the central star and the one on each side of it. By applying this rule or yard to any of the spaces of the firmament, the number of degrees which intervenes between any two objects may be nearly ascertained. *Orion* is the most striking and splendid of all the constellations; and as the equator runs through the middle of it, it is visible from all the habitable parts of the globe. About the middle of January it is nearly due south at nine o'clock in the evening.

I have been somewhat particular in the above sketches of the apparent motions and phenomena of the heavens, because such descriptions are seldom or never given in elementary treatises; because I wish every lover of the science of astronomy to contemplate with his own eyes the scenery of the sky; and because such views and observations of the general aspect of the heavens are necessary in order to understand the true system of the universe.

## CHAPTER II.

### ON THE GENERAL ARRANGEMENT OF THE PLANETARY SYSTEM.

WHEN we take an attentive view of the nocturnal heavens at different periods, we find that the stars never shift their positions with respect to each other. The stars, for instance, that form the constellation of *Orion*, preserve the same relative positions to each other every succeeding day, and month, and year. They exhibit the same general figure which they presented in the days of our fathers, and even in the times of *Amos* and of *Job*. We never see the three stars in the belt, which *Job* calls "the bands of *Orion*," move nearer to, or farther from, each other. We never see the pointers in the Great Bear directed on any other line than toward the pole-star, nor do we see *Aldebaran* to the north or south, or to the west, of the seven stars; and the same may be

said, with two or three exceptions, in regard to all the stars in the heavens, which preserve invariably the same general relations to each other from one year and century to another. Hence they have been denominated *fixed stars*. But when an attentive observer surveys the heavens with minuteness, he will occasionally perceive some bodies that shift their positions. When the movements of these bodies are carefully marked, they will be found to direct their course sometimes to the east, at other times to the west, and at certain times to remain in a fixed position; but on the whole, their motion is generally from west to east. Their motion is perceived by their appearing sometimes on one side of a star and sometimes on another. They appear to partake of



the general diurnal motion of the heavens, and rise and set with the stars to which they are adjacent. These bodies have received the name of *planets*, that is, *wandering stars*; and, indeed, were their real motions such as they appear to a common observer, the name would be exceedingly appropriate. For their apparent motions are, in many instances, exceedingly irregular; and, were they delineated on paper, or attempted to be exhibited by machinery, they would appear an almost inextricable maze. Ten bodies of this description have been discovered in the heavens, five of which are invisible to the naked eye, and can only be perceived by means of telescopes. They were, of course, unknown to the ancients. The names of the five which have been known in all ages are, Mercury, Venus, Mars, Jupiter, and Saturn. The names of the other five, which have been discovered within the last sixty years, are, Vesta, Juno, Ceres, Pallas, and Uranus, or Herschel.

It was long before the true magnitudes and real motions of these globes were fully ascertained.—Most of the ancient astronomers supposed that the earth was a quiescent body in the center of the universe, and that the planets revolved around it in so many different heavens, which were nearly concentric, and raised one above another in a certain order. The first or lowest sphere was the *Moon*, then *Mercury*, and, next in order, *Venus*, the *Sun*, *Mars*, *Jupiter*, *Saturn*, and then the sphere of the fixed stars. They found it no easy matter to reconcile the daily motion, which carries the stars from east to west, with another peculiar and slow motion, which carries them round the poles of the ecliptic, and from west to east, in the period of 25,000 years; and, at the same time, with a third motion, which carries them along from east to west in a year, around the poles of the ecliptic. They were no less at a loss how to reconcile the *annual* and *daily* motions of the sun, which are directly contrary to each other.—An additional difficulty was found in the particular course pursued by each individual planet. It required no little ingenuity to invent celestial machinery to account for all the variety of motions which appeared among the heavenly orbs. After the first *mobiles*, or powers of motion, they placed some very large heavens of solid crystal, which, by rolling one over another, and by a mutual and violent clashing, communicated to each other the universal motion received from the *primum mobile*, or first mover; while, by a contrary motion, they resisted this general impression, and, by degrees, carried away, each after its own manner, the planet for the service of which it was designed.—These heavens were conceived to be *solid*; otherwise the upper ones could have had no influence on the lower to make them perform their daily motion, and they behoved to be of the *finest crystal*, because the light of the stars could not otherwise penetrate the thickness of these arches applied one over another, nor reach our eyes. Above the sphere of the fixed stars were placed the first and second crystalline heavens, and above these the *primum mobile*, which carried round all the subordinate spheres. They imagined that the *primum mobile* was circumscribed by the empyreal heaven, of a cubic form, which they supposed to be the blessed abode of departed souls. Some astronomers were contented with seven or eight different spheres, while others imagined no less than seventy of them wrapped up one within another, and all in separate motions. They no sooner discovered some new motion or effect, formerly unknown, than they immediately set to work and

patched up a new sphere, giving it such motions and directions as were deemed requisite. Cycles, epicycles, deferents, centric and eccentric circles, solid spheres, and other celestial machinery, were all employed to solve the intricate motions of the heavens, which seemed to baffle all the efforts of human ingenuity. After their system was supposed to be completed, new anomalies were detected, which required new pieces of machinery to be applied to solve appearances. But after all the ingenuity displayed in their patchings and re-patchings, the celestial spheres could never be got to move onward in harmony, and in accordance with the phenomena of the heavens.\*

It would be no easy task to describe how their epicycles could be made to move through the thick crusts of crystal of which their spheres were made. They, however, found some means or other to extricate themselves from every difficulty, as they always had recourse to geometrical lines, which never found any obstacle to their passage on paper. To make all the pieces of their machinery move with as much smoothness and as little inconsistency as possible, they were forced to delineate certain furrows, or to notch on the arches certain grooves, in which they jointed and made the tenons and mortises of their epicycles to slide. All this celestial joiner's work, to which succeeding astronomers added several pieces to produce balancings, or perpetual goings backward and forward, had no other tendency than to conceal the sublime and beautiful simplicity of nature, and to prevent mankind, for many ages, from recognizing the true system of the world.—With all their cumbrous and complicated machinery, they never could account for the motions and other phenomena of Mercury and Venus, and the different apparent magnitudes which the planets present in different parts of their orbits.—Without admitting the motion of the earth, it would surpass the wisdom of an angel, on any rational principles, to solve the phenomena of the heavens. This is the system which has been denominated the *Ptolemaic*, from Ptolemy, an astronomer of Egypt, who first gave a particular explanation of its details; but it is understood to have been received by the ancient Greek philosophers except the Pythagoreans. It was supported by Aristotle, who wrote against the motion of the earth; and as the authority of this philosopher was thought sufficient to establish the opinion of the earth being a quiescent body, it was generally received by the learned in Europe until the sixteenth century, or a little after the period of the Reformation. This is the system to which almost all our theological writers, even of the seventeenth century, uniformly refer, when alluding to the heavenly bodies and to the general frame of the world; and, in consequence of admitting so absurd and untenable a theory, their reflections and remarks in reference to the objects of the visible world, and many of their comments on Scripture, are frequently injudicious and puerile, and, in many instances, worse than useless. That such a clumsy and bungling system was so long in vogue, is a disgrace to the ages in which it prevailed, and shows that even the learned were more prone to frame hypotheses and to submit to the authority of Aristotle, than to follow the path of observation, and to contemplate with their own eyes the phenomena of the universe. To suppose that the Architect of nature was the author of such a complex and clumsy piece of machinery, was little short of a libel on his perfections, and a

\* See La Pluche's "*Spectacle De la Nature*."



virtual denial of his infinite wisdom and intelligence

"Oh how unlike the complex works of man,  
Heaven's easy, artless, unencumber'd plan!"

From this brief sketch of the Ptolemaic system, we may learn into how many absurdities we involve ourselves by the denial of a single important fact and the admission of a single false principle; and the importance of substantiating every fact and proving every principle in all our investigations of the system of nature and the order of the universe.

The first among the moderns who had the boldness to assail the ancient system which had so long prevailed, was the famous *Nicolaus Copernicus*, who was born at Thorn, in Polish Prussia, in 1472, and died at Worms, where he had been made a canon of the church by his mother's brother, who was bishop of that place. His attention was early directed to the sciences of mathematics and astronomy. Having traveled into Italy for the purpose of enlarging his knowledge on such subjects, he remained some time at Bologna with Dominicus Maria, an eminent professor of astronomy, and afterward went to Rome, where he soon acquired so great a reputation that he was chosen professor of mathematics, which he taught for a long time with great applause. At the same time he was unwearied in making celestial observations. Returning to his own country, he began to apply his vast knowledge in mathematics to correct the system of astronomy which then prevailed. Having applied himself with assiduity to the study of the heavens, he soon perceived that the hypothesis of the ancient astronomers was conformable neither to harmony, uniformity, nor reason. With a bold independent spirit, and a daring hand, he dashed the crystalline spheres of Ptolemy to pieces, swept away his cycles, epicycles, and deferents, stopped the rapid whirl of the primum mobile, fixed the sun in the center of the planetary orbs, removed the earth from its quiescent state, and set it in motion through the ethereal void along with the other planets, and thus introduced simplicity and harmony into the system of the universe. But such a bold attack on ancient systems, which had been so long venerated, could not be made without danger. Even the learned set themselves in opposition to such bold innovations in philosophy; the vulgar considered such doctrines as chimeras, contrary to the evidence of the senses, and allied to the ravings of a maniac; and the church thundered its anathemas against all such opinions as most dangerous heresies. When only about thirty-five years of age, Copernicus wrote his book "On the Revolution of the Celestial Orbs;" but, fearing the obloquy and persecution to which his opinions might expose him, he withheld its publication, and communicated his views only to a few friends. For more than thirty years he postponed the publishing of this celebrated work, in which his system is demonstrated; and it was with the utmost difficulty, even in the latter part of his life, that he could be prevailed upon to usher it into the world. Overcome, at length, by the importunity of his friends, he put the work in order, and dedicated it to Pope Paul III; in which dedication, not to shock received prejudices, he presented his system under the form of a hypothesis. "Astronomers," said he "being permitted to imagine circles to explain the motion of the stars, I thought myself equally entitled to examine if the supposition of the motion of the earth would render the theory of these appearances more exact and simple."—

The work was printed at Nuremberg at the expense of his friends, who wrote a preface to it, in order to palliate as much as possible, so extraordinary an innovation. But its immortal author did not live to behold the success of his work. He was attacked by a bloody flux, which was succeeded by a palsy in his left side; and only a few hours before he breathed his last he received a copy of his work, which had been sent to him by one of his scientific friends. But he had then other cases upon his mind, and compositively resigned his soul to God on the 23d of May, 1543, in the seventy-first year of his age. His remains were deposited in the cathedral of Frauenberg; and spheres cut in relief on his tomb were the only epitaph that recorded his labors. Not many years ago his bones were wantonly carried off to gratify the impious curiosity of two Polish travelers.\*

The system broached by Copernicus, notwithstanding much opposition, soon made its way among the learned in Europe. It was afterward powerfully supported by the observations and reasonings of Galileo, Kepler, Halley, Newton, La Place, and other celebrated philosophers, and now rests on a foundation firm and immutable as the laws of the universe. The introduction of this system may be considered an era as important in philosophy as that of the Reformation was in politics and religion. It had even a bearing upon the progress of religion itself, and upon the views we ought to take of the character and operations of the Creator. It paved the way for a rational contemplation of his works, and for all those brilliant discoveries in the celestial regions which have expanded our views of his adorable perfections, and of the boundless extent of his universal empire. It was promulgated nearly at the same period when the superstitions of the dark ages were beginning to be dissipated; when the power of the Romish church had lost its ascendancy; when the art of printing had begun to illuminate the world; when the mariner's compass was applied to the art of navigation; when the western continent was discovered by Columbus; and when knowledge was beginning to diffuse its benign influence over the nations; and, therefore, it may be considered as connected with that series of events which are destined, in the moral Government of God, to enlighten and renovate the world.

I shall now proceed to consider the arrangement of the planetary or Copernican system, and some of the arguments by which it is supported.

In this system the sun is considered as placed near the center. Around this central luminary the planets perform their revolutions in the following order:—First, the planet Mercury, at the distance from the sun's center of about 37 millions of miles. Next to Mercury is Venus, distinguished by the name of the morning and evening star, at the distance of 31 millions of miles from the orbit of Mercury, and 68 millions from the sun. The Earth is considered as the planet next in order, which revolves at the distance of 95 millions of miles from the sun, and 27 millions from the orbit of Venus. Farther from the sun than the Earth is the planet Mars, which is 145 millions of miles from the sun, and 50 millions beyond the orbit of the Earth. Next to the orbit of Mars are four small planetary bodies, some-

\* A fac-simile of one of the letters of Copernicus may be seen in No. IX of the "Edinburgh Philosophical Journal," for July, 1821; and an engraving of the house in which he lived in No. XIII of the same Journal for July, 1822.

times named *Asteroids*, which were discovered at different times about the beginning of the present century. They are named *Vesta*, *Juno*, *Ceres*, and *Pallas*. Of these, the first in order from the sun is *Vesta*, at the distance of 225 millions of miles; the next, *Juno*, at the distance of 253 millions. *Ceres*, at 260 millions; and *Pallas*, at 256 millions of miles. The planet *Jupiter* is the next in order, and performs its revolution in an orbit 495 millions of miles from the sun, and 400 from the orbit of the earth. *Saturn* is nearly double the distance of *Jupiter* from the sun, being distant from that orb above 900 millions of miles. The most distant planet in the system which has yet been discovered is *Uranus*, or *Herschel*, which is removed from the sun at more than double the distance of *Saturn*; namely, above 1800 millions of miles. The orbit of this planet includes the orbits of the whole of the bodies of the solar system that have hitherto been discovered, and is eleven thousand three hundred millions of miles in circumference, and three thousand six hundred millions in diameter. To move round this circumference at the rate of thirty miles every hour would require above forty-two thousand nine hundred years. Such is the order, and such are the ample dimensions of that system of which we form a part; and yet it is but a mere speck in the map of the universe. The following diagram exhibits the order of the planets in the solar system.

Fig. 5.

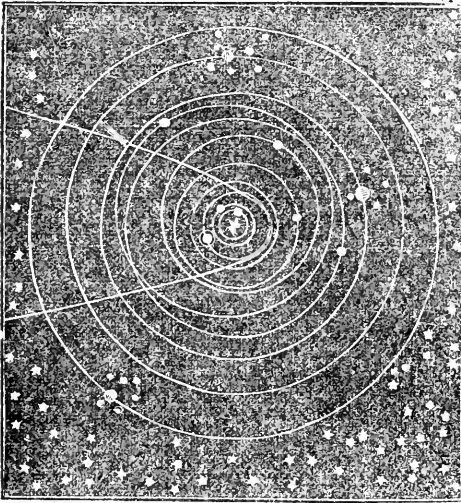

In the foregoing figure the small central star represents the sun, and the circles represent the orbits of *Mercury*, *Venus*, the *Earth*, *Mars*, *Vesta*, *Juno*, *Ceres*, *Pallas*, *Jupiter*, *Saturn*, and *Uranus*, in the order here enumerated. The orbits of the new planets, *Vesta*, *Juno*, *Ceres*, and *Pallas*, are represented as crossing each other, as they do in nature; and the portion of a long ellipse which crosses the orbits of all the planets represents the orbit of a comet. The *proportional distances* and *magnitudes* of the planets are represented in a subsequent chapter.

I shall now proceed to offer a few arguments or demonstrations of the truth of the solar system, as first proposed by *Copernicus*, and now received by all astronomers. I shall first state those which may be called *presumptive arguments*, or which amount to a high degree of probability, and then

briefly illustrate those which I consider as demonstrative. Having already endeavored to prove the diurnal rotation of the earth, I shall consider that point as settled, and confine myself, at present, to the consideration of the earth's *annual revolution*, and the phenomena of the planets which result from this motion.

The presumptive arguments that the earth is a planetary body, and revolves round the sun in concert with other planets, are, 1. *It is most simple and agreeable to the general arrangements of the Creator* that such an order as we have now stated should exist in the planetary system. For, by the motion of the earth, all the phenomena of the heavens are resolved and completely accounted for, which they cannot be on any other system, without the supposition of clumsy and complex machinery and motions altogether repugnant to reason and to what we know of the other operations of the all-wise Creator. Beside, it is contrary to the first rule laid down in philosophy,—“That more causes of natural things are not to be admitted than are both true and sufficient to explain the phenomena.” But the Ptolemaic, or vulgar system of the world, assumes the existence of facts which can never be established, and introduces cumbersome and complicated motions which are quite unnecessary for explaining the phenomena. 2. Because it is more rational to suppose that the earth moves about the sun, than that the huge masses of the planets, some of which are a thousand times larger than our globe—or that the stupendous body of the sun, which is thirteen hundred thousand times greater—should perform a revolution around so comparatively small a globe as the earth. To suppose the contrary, would be repugnant to all the laws of motion that are known to exist in the universe. We might as well expect that a sling, which contains a millstone in it, may be fastened to a pebble, and continue its motion about that pebble without removing it, as that the sun can revolve about the earth while the earth continues immovable in the center of that motion.

3. It was a law discovered by *Kepler*, by which all the planets, both primary and secondary, are regulated, “That the squares of the periodic times of the planets’ revolutions are as the cubes of their distances;”\* but, if the sun move around the earth, that law, which is established on the most accurate observations, is completely destroyed, and the general order and symmetry of the system of nature are infringed upon and interrupted. For, according to that law, the sun would be so far from revolving about the earth in 365 days, that it would require no less than 5·9 years to accomplish one revolution, as will appear from the following calculation: The moon revolves round the earth in twenty-seven days eight hours, at the distance of 240,000 miles; the sun is placed at the distance of 95,000,000 miles. The period of the revolution of any body revolving at that distance will be found, according to the law now stated, by the following proportion: As the cube of the moon’s distance : is to the cube of the sun’s distance : : so is the square of the moon’s period : to the square of the period of any body moving about the earth at the distance of the sun. Now, the cube of the moon’s distance, 240,000, is 13,

\* For example; if one planet were four times as distant as another, it would revolve in a period eight times as long; for the cube of 4=64 is equal to the square of 8. Thus *Mars* is about four times as remote from the sun as *Mercury*, and *Uranus* four times as remote as *Jupiter*, and their periods of revolution correspond to this proportion of their distances. This argument, when properly understood, is demonstrative.

824,000,000,000,000; the cube of the sun's distance, 95,000,000, is 857,375,000,000,000,000,000. The square of the moon's periodical time, twenty-seven days eight hours, is 747, which, multiplied by the cube of the sun's distance, and divided by the cube of the moon's distance, is 46,329,508,463, the square root of which is 215,242 days, or 589 years and 257 days. This calculation is of itself sufficient to determine the point in question, for there is no exception known to the law we have stated. Beside, did the sun observe this universal law, and yet revolve in 365 days, his distance ought to be only about 1,351,000 miles, whereas it can be shown that it is about 95,000,000. For, as the square of the moon's period, 747 : is to the square of the sun's,  $365 \times 365 = 133,225$  : so is the cube of the moon's distance from the earth 13,824,000,000,000,000 : to 2,465,465,050,240,963,855, the cube root of which is 1,351,295, or one million, three hundred and fifty-one thousand, two hundred and ninety-five miles, which should be the sun's distance if he revolved about the earth in accordance with this universal law, which governs every moving body, both primary and secondary.\*

4. It appears most reasonable to conclude that the sun is placed near the center of the planetary system, as it is the fountain of light and heat for cheering and irradiating all the worlds within the sphere of its influence; and it is from the center alone that these emanations can be distributed in uniform and equable proportions to all the planets. If the earth were in the center, with the sun and planets revolving around it, the planetary worlds would be, at different times, at very different distances from the sun; and, when nearest to him, would be scorched with excessive heat, and at their greatest distance would be frozen with excessive cold; and as some of the planets would, on this supposition, be sometimes five times the distance from the source of light and heat which they are at other times, it would produce the same effect as if the earth were occasionally to be carried beyond the orbit of Jupiter, four hundred and seventy millions of miles from its present position. But if the sun be considered as placed in the center of the system, we have then presented to our view a system of universal harmony and order: the planets all revolving around the great central orb by the universal law or power of gravitation, and everything corresponding to the laws of circular motion and central forces; otherwise we are left entirely in the dark as to the operations of nature and the system of the universe.

There is no more difficulty in conceiving the earth to move than that it should remain quiescent in the same place. For if the earth remain at rest *a* the center of the system, it is supported upon nothing, in the midst of infinite space, by the power of Omnipotence: and we have as little conception how a ponderous globe of the size of the earth should remain suspended upon *nothing*, as that it should move through the voids of space with a velocity of sixty-eight thousand miles an hour. The Power that is able to suspend it in empty space can as easily make it fly through the ethereal regions, as is the case with Jupiter and Saturn, which are globes a thousand times larger; and such a motion is *necessary* in order to display the harmony and proportion of the Creator's works, and to vindicate his all-perfect wisdom and intelligence. It is even no more difficult

to conceive such a motion than it is to conceive how the earth can be inhabited all round, and that there can be no such thing as *up* or *down* in the universe, absolutely considered; how, for example, persons can stand upright on the opposite sides of the globe; that our antipodes, standing with their heads in an opposite direction to ours can look *up* into the sky and *down* to the earth just as we do, without any more danger of falling off from its surface than we are of being carried upward into the air. These are circumstances which necessarily flow from the rotundity of the earth and its attractive power; they are known to every one, and cannot possibly be disputed, unless we deny the globular form of the earth, or, in other words, contradict the evidence both of our reason and our senses. But we know as little of that power which draws everything to the earth on all sides, as we do of a power which carries a planet round its orbit at the rate of a hundred thousand miles an hour. Both are effects of that Almighty agent who contrived the universe, "who is wonderful in counsel and excellent in working," and "whose ways," in numerous instances, "are past finding out." But, in all cases where the least doubt exists, we ought to adopt that view of the Creator's plans and operations which is most consistent with the ideas of a Being of infinite perfection.

The arguments now stated, although we could produce no other, would be sufficient to corroborate the idea that the earth is a planetary body, performing its motion through the depths of space; but, happily, we are able to produce proofs of the sun occupying the center of the system, which may be considered as demonstrative. These proofs I shall now state as briefly as possible.

1. In the first place, the planets Mercury and Venus are uniformly observed to have two conjunctions with the sun, but no opposition, which could not possibly happen unless the orbits of those planets lay *within* the orbit of the earth, as delineated in the plan of the solar system. This circumstance will be more particularly understood by the following diagram.

Fig. 6.

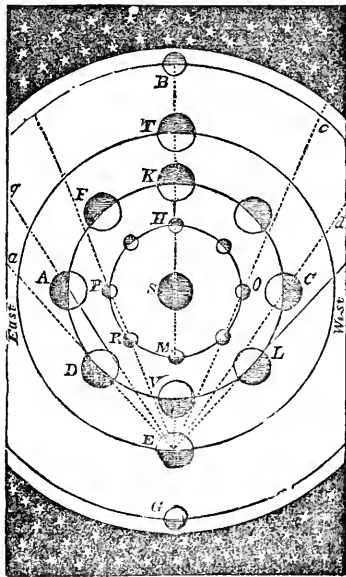

Let S represent the sun in the center of the

\* The primary planets are those which revolve about the sun as their center, as Venus, Mars, and Jupiter. The secondary planets are those which revolve around the primary, the moons of Jupiter, Saturn, and Uranus.

system, *M*, Mercury; *V*, Venus; *E*, Earth; and *G*, Mars. It is evident that when Mercury is at *M* and Venus at *V*, they will be seen from the earth, *E*, in the same part of the heavens as the sun; namely, at *B*, where Mars is represented; because they are all situated in the same straight line, *E B*. In this position they are between the sun and the earth, and this is called their *inferior* conjunction. Again, when Mercury and Venus come to the situations *H*, *K*, they are again in the straight line joining the centers of the earth and sun, and are therefore seen in the same part of the heavens with that orb. In these last positions they are *beyond* the sun, which is now between them and the earth. This is called their *superior* conjunction. Here it is evident that these two planets must appear twice in conjunction with the sun, in each revolution, to a spectator on the earth at *E*; but they can never appear in *opposition* to the sun, or, in other words, they can never be seen in the east immediately after the sun has set in the west, as is the case with Mars, which may be seen at *G* when the sun appears at *B*, in the opposite direction; all which appearances are exactly correspondent with observation, but could never take place if the earth were the center of their motions.

2. The greatest *elongation* or distance of Mercury from the sun is twenty-nine degrees, and that of Venus about forty-seven degrees, which answers exactly to observation, and to the positions and distances assigned to them in the system; but if they moved round the earth as a center, they would sometimes be seen 180 degrees from the sun, or in *opposition* to him. But they have never been seen in such a position by any observer, either in ancient or modern times, nor at greater distances from the sun than those now specified. It is evident, from the figure, that when Venus is at *D*, the point of its greatest elongation, it will be seen at *a*, in the direction of *E a*, which forms an angle of forty-seven degrees with the line *E B*, or the direction of the sun as seen from the earth. In like manner Mercury, when at its greatest elongation, at *R*, will be seen at *e*, which forms a less angle than the former with the line of direction in which the sun is seen. Hence it is that Mercury is so rarely seen, and Venus only at certain times of the year; whereas, were the earth at rest in the center of the planetary orbits, these planets would be seen in all positions and distances from the sun in the same manner as the moon appears.

3. The planets Mars, Jupiter, Saturn, Uranus, and all the other superior planets, have each their *conjunctions* and *oppositions* to the sun, alternate and successively, which could not be unless their orbits were *exterior* to the orbit of the earth.— Thus, from the earth at *E* Mars will appear in conjunction with the sun at *B* and in opposition at *G*; that is, in a part of the heavens 180 degrees distant from the sun, or directly opposite to him; and the same is the case with all the planets beyond the orbit of Mars, which proves that they are all situated in orbits which *include* the orbit of the earth.

4. In the arrangements of the planets in the system, as formerly stated, they will all be sometimes much nearer to the earth than at other times; and, consequently, their brightness and splendor, and likewise their *apparent diameters*, will be proportionably greater at one time than at another. This corresponds with every day's observation. Thus the apparent diameter of Venus, when greatest, is fifty-eight seconds, and when least, about ten seconds; of Mars, when greatest

about twenty-five seconds, and when least, not above four or five seconds; so that in one part of his orbit he is five times nearer to the earth than at the opposite part, and, consequently, appears twenty-five times larger in surface. Thus, when Mars is in the point *G*, in opposition to the sun, he is the whole diameter of the earth's orbit, or 190 millions of miles nearer us than when he is in conjunction, in the point *B*. In the one case he is only 50 millions of miles distant from the earth, while in the other he is no less than 240 millions of miles; and his apparent magnitude varies accordingly. But, according to the system which places the earth in the center, the apparent magnitude of Mars, and of all the other planets, should always be equal, in whatever points of their orbits they may be situated.

5. When the planets are viewed through good telescopes, they appear with different phases; that is, with different parts of their bodies enlightened. Thus, Mars sometimes appears round, or with a full enlightened face; and at other times he presents a gibbous phase, like that of the moon three or four days before the full. Venus presents all the different phases of the moon, appearing sometimes with a gibbous phase, sometimes like a half moon, and at other times like a slender crescent. Thus, at *V*, her dark side is turned to the earth, and she is consequently invisible, unless she happens to pass across the disc of the sun, when she appears like a round black spot on the surface of that luminary. At *D* she appears like a crescent; at *A* like a half moon, because only the one-half of her enlightened side is turned toward the earth; and at *P* she presents a gibbous phase. When Copernicus first proposed his system, it was one of the strongest objections which his adversaries brought against it, and by which they supposed they had completely confuted him; namely, that "if his hypothesis were true, Venus and Mercury must vary their phases like the moon, but that they constantly appeared round." Copernicus at once admitted that these consequences were justly drawn; and he attributed the cause of their round appearances to the structure of our eyes, to the distance of the objects, and to those radiating crowns which hinder us from judging either of the size or the exact form of the stars and planets; and he is said to have prophesied that one day or other these various phases would be discovered; and little more than a half century intervened, when the telescope (which was unknown in the time of Copernicus), in the hands of Galileo, determined to a certainty the matter in dispute, and confirmed the prediction of that eminent astronomer. How great, may we suppose, would have been the transport of that illustrious man had a telescope been put into his hands, and had he seen, as we now do, that Venus, when she appears most brilliant, exhibits, in reality, the form of a crescent! so that this formidable objection to the truth of his system has now become one of the strongest and most palpable demonstrations of the reality of that arrangement which has placed the sun in the center, and set the earth in motion between Mars and Venus.

6. All the planets in their motions are seen, sometimes to move *direct*; sometimes *retrograde*; and at other times to remain *stationary*, without any apparent motion: in other words, in one part of their course they appear to move to the east; in another part to the west; and at certain points of their orbits they appear fixed for some time in the same position. Thus, Venus, when she passes from her greatest elongation westward, at *L*, to her elongation eastward, at *D*, through the arc

*LCKFAD*, will appear *direct* in motion, or from west to east; but as she passes from *D* to *L*, through the arc *DVL*, she will appear *retrograde*, or as if she were moving from east to west. When she is in those parts of her orbit most distant from the sun, as at *D* and *L*, she will appear for some time stationary, because the tangent line or visual ray appears to coincide for some time with the orbit of the planet; just as a ship at a great distance, when moving directly toward the eye in the line of vision, appears for a little time to make no progress. All these apparent diversities of motion are *necessary* results of the Copernican system, and they coincide with the most accurate observations; but they are altogether inexplicable on any other hypothesis.

7. The planets Mercury and Venus, in their superior conjunctions with the sun, as at *H* and *K*, are sometimes hid behind the sun's body; which could never happen on the Ptolemaic hypothesis, because in it the orbit of the sun is supposed to be *exterior* to the orbits of these two planets.

8. The *times* in which these conjunctions, oppositions, direct and retrograde motions, and stationary aspects of the planets happen, are not such as they would be if the earth were at rest in its orbit; but *precisely* such if the earth move, and all the other planets in the periods assigned them. Thus, suppose Venus at any time in conjunction with the sun at *V*; were the earth at rest in *E*, the next conjunction of the same kind would happen again when Venus had made just one revolution, that is, in 224 days. But this is contrary to experience; for a much longer time is found to intervene between two conjunctions of the same kind, as must be if we suppose the earth to have a motion in the same direction. For, when Venus comes to the point *V*, the earth will if the earth were considered as remaining fixed in the center of its motion. On each side of the loops in the figure it appears stationary; in that part of the loop next the earth it appears retrograde; and in all the rest of the path, which seems to stretch far away from the earth, it appears direct, until its course again appears to run into a loop. Let the reader trace the whole of the curve here delineated, and then ask himself whether such motions can possibly be real, or the contrivances of Infinite Wisdom. The motions of Venus, and all of the superior planets, as seen from the earth, present similar curves and anomalies. Now it is a fact, that when the earth is considered as moving round the sun in a year, between the orbits of Venus and Mars, all these apparent irregularities are completely accounted for by the combination of motions produced by our continual change of position, in consequence of the earth's progress in its annual orbit; and thus the movements of all the planets are reduced to perfect harmony and order.

Such is a brief summary of the leading proofs which may be brought forward to establish the fact of the annual motion of the earth round the sun. They all converge toward the same point, and hang together in perfect harmony. It is next to impossible that such a combination of arguments could be found to prove a false position. When thoroughly understood and calmly considered they are calculated to produce on the mind of every unbiased inquirer as strong a conviction of the point

have passed in that time from *E* to some other part of its orbit, and from this part still keeps moving on until Venus overtakes it, and gets again between it and the sun. The period which Venus will take before she overtakes the earth and comes in conjunction with the sun, is found as follows: The daily mean motion of the earth is fifty-nine minutes eight seconds (which is the same as the *apparent* mean motion of the sun), and the daily mean motion of Venus is one degree, thirty-six minutes, eight seconds. The difference of these mean motions is thirty-seven minutes. Therefore, as 37 : is to the number of minutes in the whole circle of 360 degrees, namely, 21600 : : so is one day : to 583 days, 18 5-4 hours, which is the time between two conjunctions of the same kind, or one year and a little more than seven months, which is somewhat more than two and a half revolutions of Venus, and which perfectly agrees with the most accurate observations.

In the last place, if we were to suppose the earth at rest in the center of the planetary system, the *motions* of all the planets would present a scene of *inextricable confusion*. They would appear so irregular and anomalous that no rational being would ever suppose they could be the contrivances of an All-wise Being, possessed of every perfection. This will appear at once by casting the eye on Fig. 7, which represents the apparent motion of the planet Mercury, as seen from the earth, from the year 1708 to 1715, as originally delineated by the celebrated astronomer Cassini, and published in the Memoirs of the Royal Academy of Sciences. Here the motion of this planet appears to describe a complicated curve, or a series of loops or spirals running into each other, instead of a regular circular motion in an orbit; and such irregular curves must be the *real* motion of the planet, to account for all its appearances,

Fig. 7

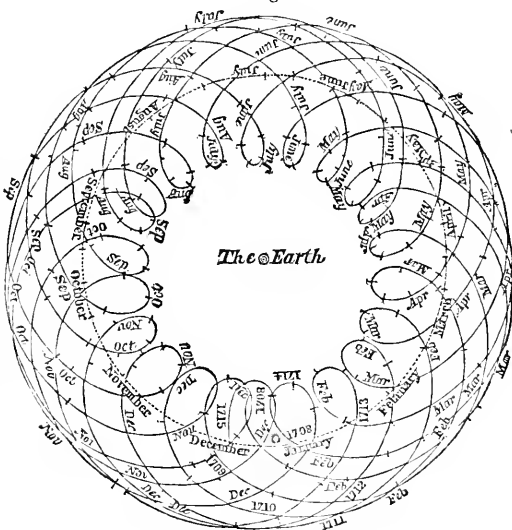

in question, as if, from a fixed position in the heavens, we actually beheld the earth and all its population sweeping along through the ethereal spaces with the velocity of sixty-eight thousand miles every hour. These arguments are plain and easy to be understood if the least attention be bestowed. Most of them require nothing more than common observation, or, in

other words, common sense, in order to understand and appreciate them; and he who will not give himself the trouble to weigh them with attention must be contented to remain in ignorance. I have stated them with more particularity than is generally done in elementary books on this subject, because they lie at the foundation of astronomical science, and of all our views of the amplitude and order of the universe: and because many profess to believe in the motion of the earth merely on the authority of others, without examining the grounds of their belief, and, consequently, are never fully and rationally convinced of the important position to which we have adverted.

The motion of the earth presents before us a *most sublime and august object of contemplation*. We wonder at beholding a steam carriage, with all its apparatus of wagons and passengers, carried forward on a railway at the rate of thirty miles an hour, or a balloon sweeping through the atmosphere with a velocity of sixty miles in the same time. Our admiration would be raised still higher, should we behold Mount Etna, with its seventy cities, towns, and villages, and its hundred thousand inhabitants, detached from its foundations, carried aloft through the air, pouring forth torrents of red-hot lava, and impelled to the continent of America in the space of half an hour. But such an object, grand and astonishing as it would be, could convey no adequate idea of the grandeur of such a body as the earth flying through the voids of space in its course round the sun. Mount Etna, indeed, contains a mass of matter equal to more than 800 cubical miles, but the earth comprises an extent of more than 263,000,000,000 of solid miles, and, consequently, is more than three hundred millions of times larger than Etna, and of a much greater density. The comparative size of this mountain to the earth may be apprehended by conceiving three hundred millions of guineas laid in a straight line, which would extend 4700 miles, or from London to the equator, or to south America. The whole line of guineas throughout this vast extent would represent the bulk of the earth, and a single guinea, which is only about an inch in extent, would represent the size of Etna compared with that of the earth. Again: Etna, in moving from its present situation to America in half an hour, would move only at the rate of 130 miles in

a minute; while the earth in its annual course flies with a velocity of more than 1130 miles in the same space of time, or about nine times that velocity.

How august, then, and overpowering the idea, that during every pulse that beats within us we are carried nearly twenty miles from that portion of absolute space we occupied before! that during the seven hours we repose in sleep, we, and all the inhabitants of the world, are transported 470,000 miles through the depths of space; that during the time it would take to read deliberately from the beginning of the last paragraph to the present sentence, we have been carried forward with the earth's motion more than 4509 miles; and that, in the course of the few minutes we spend in walking a mile, we are conveyed through a portion of absolute space to the extent of more than 18,000 miles. What an astonishing idea does such a motion convey of the ENERGIES of the Almighty Creator, especially when we consider that thousands of rolling worlds, some of them immensely larger than our globe, are impelled with similar velocities, and have, for many centuries past, been running without intermission their destined rounds! Here, then, we have a magnificent scene presented to view, far more wonderful than all the enchanted palaces rising and vanishing at the stroke of the magician's rod, or all the scenes which the human imagination has ever created, or the tales of romance have recorded, which may serve to occupy our mental contemplation when we feel *ennui*, or are at a loss for subjects of amusement or reflection. We may view in imagination this ponderous globe on which we reside, with all its load of continents, islands, oceans, and its millions of population wheeling its course through the heavens at a rate of motion, *every day*, exceeding 1,600,000 miles, we may transport ourselves to distant regions and contemplate globes far more magnificent moving with similar or even greater velocities we may wing our flight to the starry firmament where worlds unnumbered run their ample rounds where suns revolve around suns, and systems around systems, around the throne of the Eternal; until, overpowered with the immensity of space and motion, we fall down with reverence, and worship Him who presides over all the departments of universal nature, "who created all worlds, and for whose pleasure they are and were created."

## CHAPTER III.

### ON THE MAGNITUDES, MOTIONS, AND OTHER PHENOMENA OF THE BODIES CONNECTED WITH THE SOLAR SYSTEM

In the elucidation of this subject, I shall, in the first place, present a few sketches of the magnitudes, motions, and other phenomena of the primary planets belonging to the solar system. These planets, as formerly stated, are, Mercury, Venus, Mars, Vesta, Juno, Ceres, Pallas, Jupiter, Saturn, and Uranus, which are here mentioned in the order of their distance from the sun.

In this order I shall proceed to give a few descriptions of the principal facts which have been ascertained respecting each planet.

#### I THE PLANET MERCURY.

This planet is the nearest to the sun of any that have yet been discovered, although a space of no less than thirty-seven millions of miles intervene between Mercury and the central luminary. Within this immense space several planets may revolve, though they may never be detected by us, on account of their proximity to the sun. To an inhabitant of Mercury, such planets, if any exist, may be as distinctly visible as Venus and

Mercury are to us; because they will appear, in certain parts of their course, at a much greater elongation from the sun than they can to us. This planet, on account of its moving in the neighborhood of the sun, is seldom noticed by a common observer. It is only to be seen by the naked eye about the period of its greatest elongation from the sun, which is sometimes only about 16° or 17°, and never exceeds 29°. These elongations happen, at an average, about six or seven times every year; about three times when the planet is eastward of the sun, and three times when it is to the westward. This planet, therefore, can only be seen by the unassisted eye for a few days about these periods, either in the morning a little before sunrise, or in the evenings a little after sunset. As it is sometimes not above 16°, even at its greatest elongation, from the point of sunrise or sunset, and is likewise very near the horizon, it is sometimes very difficult to distinguish it by the naked eye, and at all other times it is generally imperceptible without a telescope. It is said that the celebrated astronomer, Copernicus, had never an opportunity of seeing this planet during the whole course of his life. I have seen Mercury three or four times with the naked eye, and pretty frequently with a telescope. With a magnifying power of 150 times, I have seen it about the time of its greatest elongation, more than half an hour after sunrise, when it appeared like a small brilliant half moon; but no spots could be discovered upon it. To the naked eye, when it is placed in a favorable position, it appears with a brilliant white light, like that of Venus, but much smaller and less conspicuous. The best mode of detecting it is by means of an equatorial telescope, which, by a slight calculation and the help of an ephemeris, may be directed to the precise point of the heavens where it is situated. The most favorable seasons of the year for observing it are when its greatest elongations happen in the month of March or April, and in August or September. In winter it is not easily perceived, on account of its very low altitude above the horizon at sunrise and sunset; and in summer, the long twilight prevents our perception of any small object in the heavens. From the planets Saturn and Uranus, Mercury would be altogether invisible, being completely immersed in the splendor of the solar rays; so that an inhabitant of these planets would never know that such a body existed in the universe, unless he should happen to see it when it passed, like a small dark point, across the disc of the sun.

Mercury revolves around the sun in the space of eighty-seven days twenty-three hours, which is the length of its year; but the time from one conjunction to the same conjunction again, is about 116 days; for as the earth has moved about a fourth part of its revolution during this period, it requires nearly thirty days for Mercury to overtake it, so as to be in a line with the sun. During this period of about 116 days it passes through all the phases of the moon, sometimes presenting a gibbous phase, sometimes that of a half moon, and at other times the form of a crescent; which phases and other particulars will be more particularly explained in the description I shall give of the planet Venus. Mercury, at different times, makes a transit across the sun's disc; and as its dark side is then turned to the earth, it will appear like a round spot upon the face of the sun; and when it passes near the center of the sun, it will appear for the space of from five to seven hours on the surface of that orb. Its last transit happened on the 7th of November, 1855,

which was visible in the United States of America, but not in Britain, as the sun was set before its commencement. The next transits, to the end of the present century, are as follows-

	Hours.	Minutes.
1845, May 8th.....	7	54 P. M.
1848, November 9th.....	1	38 P. M.
1861, November 12th.....	7	20 P. M.
1868, November 5th.....	6	44 A. M.
1878, May 6th.....	6	38 P. M.
1881, November 8th.....	0	49 A. M.
1891, May 10th.....	2	45 A. M.
1894, November 10th.....	6	17 P. M.

The time stated in the above table is the mean time of conjunction at Greenwich, or nearly the middle of the transit; so that, in whatever part of the world the sun is risen at that time, the transit will be visible if no clouds interpose. The next two transits, in 1845 and 1848, will be partly visible in Britain.

Few discoveries have been made on the surface of this planet by means of the telescope, owing to the dazzling splendor of its rays, which prevents the telescope from presenting a well-defined image of its disc; owing, likewise, to the short interval during which observations can be made, and particularly to its proximity to the horizon, and the undulating vapors through which it is then viewed. That unwearied observer of the heavens, Sir William Herschel, although he frequently viewed this planet with magnifying powers of 200 and 300 times, could perceive no spots or any other phenomenon on its disc from which any conclusions could be deduced respecting its peculiar constitution or the period of its rotation. Mr. Schroeter, an eminent German astronomer, however, appears to have been more successful. This gentleman has long been a careful observer of the phenomena of the planetary system, by means of telescopes of considerable size, and has contributed not a few interesting facts to astronomical science. He assures us that he has seen not only spots, but even mountains on the surface of Mercury, and that he succeeded in ascertaining the altitude of two of these mountains. One of them he found to be little more than 1000 toises in height, or about an English mile and 372 yards. The other measured 8900 toises, or ten miles and 1378 yards, which is more than four times higher than Mount Etna or the Peak of Teneriffe. The highest mountains are said to be situated in the southern hemisphere of this planet. The same observer informs us, that, by examining the variation in the daily appearance of the horns or cusps of this planet, when it appeared of a crescent form, he found the period of its diurnal rotation round its axis to be twenty-four hours, five minutes, and twenty-eight seconds. But these deductions require still to be confirmed by future observations.

The light or the intensity of solar radiation which falls on this planet is nearly seven times greater than that which falls upon the earth; for the proportion of their distances from the sun is nearly as three to eight, and the quantity of light diffused from a luminous body is as the square of the distance from that body. The square of 3 is 9, and the square of 8, 64, which, divided by 9, produces a quotient of 7 1-9, which nearly expresses the intensity of light on Mercury compared with that on the earth. Or, more accurately, thus: Mercury is 36,880,000 miles from the sun, the square of which is 1,360,134,400, 000,000; the earth is distant 95,000,000, the

square of which is, 9,025,000,000,000,000. Divide this last square by the first, and the quotient is about  $6\frac{2}{3}$ , which is very nearly the proportion of light on this planet. As the apparent diameter of the sun is likewise in proportion to the square of the distance, the inhabitants of this planet will behold in their sky a luminous orb, giving light by day, nearly seven times larger than the sun appears to us; and every object on its surface will be illuminated with a brilliancy seven times greater than are the objects around us in a fine summer's day. Such a brilliancy of luster on every object would completely dazzle our eyes in their present state of organization; but in every such case we are bound to believe that the organs of vision of the inhabitants of any world are exactly adapted to the sphere they occupy in the system to which they belong. Were we transported to such a luminous world as Mercury, we could perceive every object with the same ease and distinctness we now do, provided the pupil of the eye, instead of being one-eighth of an inch in diameter, as it now is, were contracted to the size of one-fiftieth of an inch. In consequence of the splendor which is reflected from every object on this planet, it is likely that the whole scenery of nature will assume a most glorious and magnificent aspect, and that the *colors* depicted on the various parts of the scenery of that world will be much more *vivid* and *splendid* than they appear on the scenery of our terrestrial mansion; and since it appears highly probable that there are elevated mountains on this planet, if they be adorned with a diversity of color, and of rural and artificial objects, they must present to the beholder a most beautiful, magnificent, and sublime appearance. The following figures will present to the eye a comparative view of the apparent size of the sun, as beheld from Mercury and from the earth.

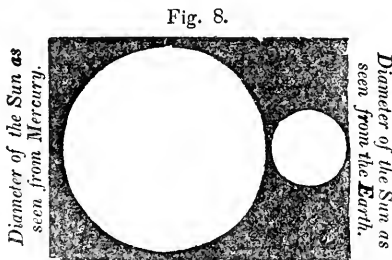

While the intensity of the solar light on this planet is about seven times greater than on the earth, the light on the surface of Uranus, the most distant planet of the system, is 360 times less than that on the earth; for the square of the earth's distance, as formerly stated, is 9,025,000,000,000,000, and the square of the distance of Uranus from the sun, 1,800,000,000, of miles, is 3,240,000,000,000,000,000, which, divided by the former number, gives a quotient of 359 and a fraction, or, in round numbers, 360; the number of times that the light on the earth exceeds that on Uranus. Yet we find that the light reflected from that distant planet, after passing 1,800,000,000 of miles from the body of the sun, and returning again by reflection 1,700,000,000 of miles to the earth, is visible through our telescopes, and even sometimes to the naked eye. Thus it appears that the intensity of light at the two extremes of the solar system is in the proportion of 2400 to 1; for  $3606 \times \frac{2}{3} = 2400$ , the number of times that the quantity of light on Mercury ex-

ceeds that on Uranus. But we may rest assured, from what we know of the plans of Divine wisdom, that the eyes of organic intelligence, both at the extremes and in all the intermediate spaces of the system, are exactly adapted to the sphere they occupy and the quantity of light they receive from the central luminary.

In regard to the *temperature* of Mercury, if the intensity of *heat* were supposed to be governed by the same law as the intensity of light, the heat in this planet would, of course, be nearly seven times greater than on the earth. Supposing the average temperature of our globe to be fifty degrees of Fahrenheit's thermometer, the average temperature on Mercury would be 333 degrees, or 121 degrees above the heat of boiling water; a degree of heat sufficient to melt sulphur, to make nitrous acid boil, and to dissipate into vapor every volatile compound. But we have no reason to conclude that the degree of sensible heat on any planet is in an inverse proportion to its distance from the sun. We have instances of the contrary on our own globe. On the top of the highest range of the Andes, in South America, there is an intense cold at all times, and their summits are covered with perpetual snows, while in the plains immediately adjacent, the inhabitants feel all the effects of the scorching rays of a tropical sun. The sun, during our summer in the northern hemisphere, is more than three millions of miles further from us than in winter; and although the obliquity of his rays is partly the cause of the cold felt in winter when he is nearest us, yet it is not the *only* cause; for we find that the cold in New York and Pennsylvania is more intense in winter than in Scotland, although the sun rises from ten to sixteen degrees higher above the horizon in the former case than in the latter. Beside, we find that the heat of summer in the southern hemisphere, when the sun is nearest to the earth, is not so great as in the summer of corresponding latitudes in the northern hemisphere. In short, did heat depend chiefly on the nearness of the sun or the obliquity of his rays, we should always have the same degree of heat or cold at the same time of the year, in a uniform circle; which experience proves to be contrary to fact. The degree of heat, therefore, on any planet, and on different portions of the same planet, must depend in part, and perhaps chiefly, on the nature of the atmosphere, and other circumstances connected with the constitution of the planet, in combination with the influence of the solar rays. These rays undoubtedly produce heat, but the degree of its intensity will depend on the nature of the substances on which they fall; as we find that the same degree of sensible heat is not felt when they fall on a piece of iron or marble, as when they fall on a piece of wood or flannel.

Mercury was long considered as the smallest primary planet in the system; but the four new planets lately discovered between the orbits of Mars and Jupiter, are found to be smaller. Its diameter is estimated at 3200 miles, and consequently, its surface contains above 32,000,000 of square miles, and its solid contents are 17,157,324,800, or more than seventeen thousand millions of solid miles; and if the number of solid miles contained in the earth, which are 261,000,000,000, be divided by this sum, the quotient will be somewhat more than fifteen, showing that the earth is above fifteen times larger than Mercury. Notwithstanding the comparatively diminutive size of this planet, it is capable of containing a population upon its surface much greater than has ever been supported on the surface of the earth



during any period of its history. In making an estimate on this point, I shall take the population of England as a standard. England contains 50,000 square miles of surface, and 14,000,000 of inhabitants, which is 280 inhabitants for every square mile. The surface of Mercury contains 32,000,000 of square miles, which is not much less than all the habitable parts of our globe. At the rate of population now stated, it is sufficiently ample to contain 8,960,000,000, or eight thousand nine hundred and sixty millions of inhabitants, which is more than eleven times the present population of our globe. And although the one-half of the surface of this planet were to be considered as covered with water, it would still contain nearly six times the population of the earth. Hence it appears, that small as this planet may be considered, when compared with others, and seldom as it is noticed by the vulgar eye, it in all probability holds a far more distinguished rank in the intellectual and social system under the moral government of God, than this terrestrial world of which we are so proud, and all the living beings which traverse its surface.

I shall only mention further the following particulars in reference to this planet. In its revolution round the sun, its motion is swifter than that of any other planet yet discovered; it is no less than at the rate of 109,800 miles every hour at an average, although in some parts of its course it is slower, and in other parts swifter, since it moves in an elliptical orbit. Of course it lies 1830 miles every minute, and more than thirty miles during every beat of our pulse. The density of this planet is found by certain physical calculations and investigations, founded on the laws of universal gravitation, to be nine times that of water, or equal to that of lead; so that a ball of lead 3200 miles in diameter would exactly poise the planet Mercury. This density is greater than that of any of the other planets, and nearly twice the density of the earth. The mass of this planet, or the quantity of matter it contains, when compared with the mass of the sun, is, according to La Place, as 1 to 2,025,810, or about the two millionth part; that is, it would require two millions of globes of the size and density of Mercury to weigh one of the size and density of the sun. But as Mercury contains a much greater quantity of matter in the same bulk than the sun, in point of size it would require 22,000,000 of globes of the bulk of Mercury to compose a body equal to that of the sun. In consequence of the great density of this planet, bodies will have a greater weight on its surface than on the earth. It has been computed, that a body weighing one pound on the earth's surface would weigh one pound eight and a half drachms on the surface of Mercury. If the centrifugal force of this planet were suspended, and its motion in a circular course stopped, it would fall toward the sun, as a stone when thrown upward falls to the ground, by the force of gravity, with a velocity continually increasing as the square of the distance from the sun diminished. The time in which Mercury or any other planet would fall to the sun by the centripetal force, or the sun's attraction, is equal to its periodic time divided by the square root of thirty-two; a principle deduced from physical and mathematical investigation. Mercury would therefore fall to the sun in 15 days, 13 hours; Venus in 39 days, 17 hours; the earth in 64 days, 13 hours; Mars in 121 days, 10 hours; Vesta in 205 days; Ceres in 297 days, 6 hours; Pallas in 301 days, 4 hours; Juno in 354 days, 19 hours; Jupiter in 765 days, 19 hours, or above two years;

Saturn in 1901 days, or about five years; Uranus in 5425 days, or nearly fifteen years; and the Moon would fall to the earth, were its centrifugal force destroyed, in 4 days, 20 hours. Some of the deductions stated above may be apt to startle some readers as beyond the powers of limited intellects, and above the range of human investigation. The discoveries of Newton, however, have now taught us the laws by which these bodies act upon one another; and as the effects they produce depend very much upon the quantities of matter they contain, by observing these effects we are able, by the aid of mathematical reasoning, to determine the quantities of matter in most of the planets with considerable certainty. But to enter on the demonstration of such points would require a considerable share of attention and of mathematical knowledge, and would probably prove tedious and uninteresting to the general reader.

Mercury revolves in an orbit which is elliptical, and more eccentric than the orbits of most of the other planets, except Juno, Ceres, and Pallas. Its eccentricity, or the distance of the sun from the center of its orbit, is above 7,000,000 of miles.—The time between its greatest elongations from the sun varies from 106 to 130 days. Its orbit is inclined to the ecliptic, or the plane of the earth's orbit, in an angle of seven degrees, which is more than double the inclination of the orbit of Venus.

## H. OF THE PLANET VENUS.

Of all the luminaries of heaven, the sun and moon excepted, the planet Venus is the most conspicuous and splendid. She appears like a brilliant lamp amid the lesser orbs of night, and alternately anticipates the morning dawn and ushers in the evening twilight. When she is to the westward of the sun, in winter, she cheers our mornings with her vivid light, and is a prelude to the near approach of the break of day and the rising sun. When she is eastward of that luminary, her light bursts upon us after sunset, before any of the other twinkling orbs of heaven make their appearance; and she discharges, in some measure, the functions of the absent moon. The brilliancy of this planet has been noticed in all ages, and has been frequently the subject of description and admiration both by shepherds and by poets. The Greek poets distinguished it by the name of *Phosphor* when it rose before the sun, and *Hesperus* when it appeared in the evening after the sun retired; and it is now generally distinguished by the name of the Morning and Evening Star.

“Next Mercury, Venus runs her larger round,  
With softer beams and milder glory crown'd,  
Friend to mankind, she glitters from afar,  
Now the bright evening, now the morning star,  
From realms remote she darts her pleasing ray,  
Now leading on, now closing up the day;  
Tern'd *Phosphor* when her morning beams she yields,  
And *Hesperus* when her ray the evening gilds.”

Before proceeding to a more particular description of this planet, I shall lay before the reader a brief explanation of the nature of the planetary orbits, as I may have occasion to refer to certain particulars connected with them in the following descriptions. All the planets and their satellites move in elliptical orbits, more or less eccentric. The following figure exhibits the form of these orbits.

The figure *A D B E* represents the form of a planetary orbit, which is that of an oval or ellipse. The longest diameter is *A B*; the shorter diameter *D E*. The two points *F* and *G* are

called the *foci* of the ellipse, around which, as two of the central points, the ellipse is formed. The sun is not placed in *C*, the center of the orbit, but at *F*, one of the foci of the ellipse. When the planet,

Fig. 9.

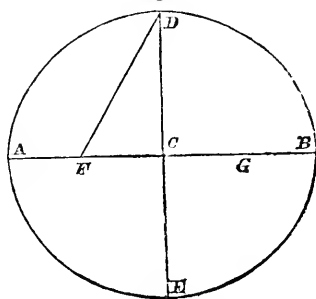

therefore, is at *A*, it is nearest the sun, and is said to be in its *perihelion*; its distance from the sun gradually increases until it reaches the opposite point, *B*, when it is at its greatest distance from the sun, and is said to be in its *aphelion*; when it arrives at the points *D* and *E* of its orbit, it is said to be at the *mean distance*. The line *AB*, which joins the perihelion and aphelion, is called the *line of the apsides*, and also the greater axis or the *transverse axis* of the orbit; *DE* is the *lesser* or *conjugate axis*; *FD*, the *mean distance* of the planet from the sun; *FC*, or *GC*, the *eccentricity* of the orbit, or the distance of the sun from its center; *F* is the *lower focus*, or that in which the sun is placed; *G* the *higher focus*; *A* the *lower apsis*, and *B* the *higher apsis*. The orbits of some of the planets are more elliptical than others.—The eccentricity of the orbit of Mercury is above 7,000,000 miles; that is, the distance from the point *F*, where the sun is placed, to the center, *C*, measures that number of miles; while the eccentricity of Venus is only about 490,900 miles, or less than half a million. Most of the planetary orbits, except those of some of the new planets, approach very nearly to the circular form.

The orbits of the different planets do not all lie in the same plane, as they appear to do in orreries and in the representations generally given of the solar system. If we suppose a plane to pass through the earth's orbit, and to be extended in every direction, it will trace a line in the starry heavens which is called the *plane of the ecliptic*, and the plane itself is called the *plane of the ecliptic*. The orbits of all the other planets do not lie in this plane, one half of each orbit rising above it, while the other half falls below it. This may be illustrated by supposing a large bowl or concave vessel to be nearly filled with water; the surface of the water will trace a circular line round the inner surface of the bowl, which may represent the ecliptic, while the surface of the water itself is the *plane of the ecliptic*, and the bowl is the one-half of the concave sky. If we now immerse in the bowl a large circular ring obliquely, so that one-half of it is above the surface of the water and the other half below, this ring will represent the orbit of a planet inclined to the ecliptic or to the fluid surface; or if we take two large rings or hoops of nearly equal size, and place the one within the other obliquely, so that the half of the one hoop may be above, and the opposite half below the other hoop, it will convey an idea of the inclination of a planet's orbit to the plane of the ecliptic. Thus, if the circle *EF G H* (Fig. 10) represent the plane of the earth's orbit or the ecliptic, the circle *A B C D*

may represent the orbit of a planet which is inclined to it; the semicircle *I A B K* being below the level of the ecliptic, and the other half or semicircle being above it. The points of intersection at *I* and *K*, where the circles cut one another, are called the *nodes*. If the planet is moving in the direction *A I D*, the point *I*, where it ascends above the plane, is called the *ascending node*, and the opposite point, *K*, the *descending*

Fig. 10.

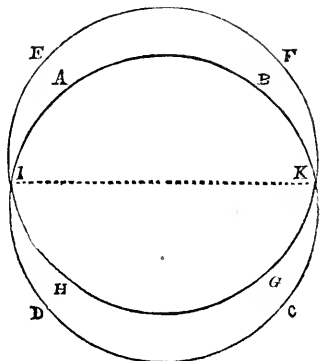

*node*. The line *I K*, which joins the nodes, is called the *line of the nodes*, which, in the different planetary orbits, points to different parts of the heavens. It is when Mercury and Venus are at or near the line of the nodes that they appear to make a transit across the sun's disc. The moon's orbit is inclined to the plane of the earth's orbit in an angle of about five degrees; and it is only when the full moon or change happens at or near the nodes that an eclipse can take place, because the sun, moon, and earth are then nearly in the same plane; at all other times of full or change, the shadow of the moon falls either above or below the earth, and the shadow of the earth either above or below the moon. The ecliptic is supposed to be divided into twelve signs, or 360 degrees, which have received the names:—*Aries, Taurus, Gemini, Cancer, Leo, Virgo, Libra, Scorpio, Sagittarius, Capricornus, Aquarius, Pisces*.—Each of these signs is divided into thirty equal parts, called *degrees*; each degree into sixty parts, or minutes; each minute into sixty parts, or seconds, &c.

Having stated the above definitions, which it may be useful to keep in mind in our further discussions, I shall proceed to a particular description of the motions and other phenomena of Venus.

*General Appearances and apparent motions of Venus*.—This planet, as already noticed, is only seen for a short time, either after sunset in the evening, or in the morning before sunrise. It has been frequently seen by means of the telescope, and sometimes by the naked eye, at noon-day, but it was never seen at midnight, as all the other planets may be, with the exception of Mercury. It never appears to recede farther from the sun than forty-seven degrees, or about half the distance from the horizon to the zenith. Of course, it was never seen rising in the east, or even shining in the south, after the sun had set in the west, as happens in regard to all the other heavenly bodies, with the exception now stated.

When this planet, after emerging from the solar rays, is first seen in the evening, it appears very near the horizon about twenty minutes after

sunset, and continues visible only for a very short time, and descends below the horizon not far from the point where the sun went down. Every succeeding day its apparent distance from the sun increases; it rises to a higher elevation, and continues a longer time above the horizon. Thus it appears to move gradually eastward from the sun for four or five months, until it arrives at the point of its greatest elongation, which seldom exceeds forty-seven degrees, when it appears for some time stationary; after which it appears to commence a retrograde motion from east to west, but with a much greater degree of apparent velocity; approaching every day nearer the sun, and continuing a shorter time above the horizon. until, in the course of two or three weeks, it appears lost in the splendor of the solar rays, and is no longer seen in the evening sky until more than nine or ten months have elapsed. About eight or ten days after it has disappeared in the evening, if we look at the eastern sky in the morning, a little before sunrise, we shall see a bright star very near the horizon, which was not previously to be seen in that quarter: this is the planet Venus, which has passed its inferior conjunction with the sun, and has now moved to the westward of him, to make its appearance as the morning star. It now appears every succeeding day to move pretty rapidly from the sun to the westward, until it arrives at the point of its greatest elongation, between  $45^{\circ}$  and  $48^{\circ}$  distant from the sun, when it again appears stationary; and then returns eastward, with an apparently slow motion, until it is again immersed in the sun's rays, and arrives at its superior conjunction, which happens after the lapse of about nine months from the time of being first seen in the morning. But the planet is not visible to the naked eye all this time on account of its proximity to the sun when slowly approaching its superior conjunction. After passing this conjunction it soon after appears in the evening, and resumes the same course as above stated. During each of the courses now described, when viewed with a telescope, it is seen to pass successively through all the phases of the moon, appearing *gibbous*, or nearly round, when it is first seen in the evening; of the form of a half moon when about the point of its greatest elongation; and of the figure of a crescent, gradually turning more and more slender as it approaches its inferior conjunction with the sun. Such are the general appearances which Venus presents to the attentive eye of a common observer, the reasons of which will appear from the following figure and explanations.

Fig. 11.

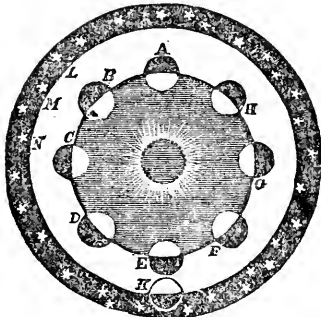

Let the earth be supposed at K; then when Venus is in the position marked A, it is nearly in a line with the sun as seen from the earth, in

which position it is said to be in its *superior* conjunction with the sun, or beyond him, in the remotest part of its orbit from the earth; in which case the body of the sun sometimes interposes between the earth and Venus; at other times it is either a little above or below the sun, according as it happens to be either in north or south latitude. When it is in this position, the whole of its enlightened hemisphere is turned toward the earth. As it moves on its orbit from A to B, which is from west to east, and is called its *direct* motion, it begins to appear in the evening after sunset. When it arrives at B, it is seen among the stars at L, in which position it assumes a gibbous phase, as a portion of its enlightened hemisphere is turned from the earth. When it arrives at C, it appears among the stars at M, at a still greater distance from the sun, and exhibits a less gibbous phase, approaching to that of a half moon. When arrived at D, it is at the point of its greatest eastern elongation, when it appears like a half moon, and is seen among the stars at N; it now appears for some time stationary; after which it appears to move with a rapid course in an opposite direction, or from east to west, during which it presents the form of a crescent, until it approaches so near the sun as to be overpowered with the splendor of his rays. When arrived at E, it is said to be in its *inferior* conjunction, and, consequently, nearest the earth. In this position it is just 27 millions of miles from the earth; whereas, at its superior conjunction, it is no less than 163 millions of miles from the earth, for it is then farther from us by the whole diameter of its orbit, which is 136 millions of miles. This is the reason why it appears much smaller at its superior conjunction than when near its inferior; although, in the latter case, there is only a small crescent of its light presented to us, while in the former case its full enlightened hemisphere is turned to the earth.

The following figure will exhibit more distinctly the *phases* of this planet in the different parts of its course, and the reason of the difference of its apparent magnitude in different points of its orbit. At A it is in the superior

Fig. 12

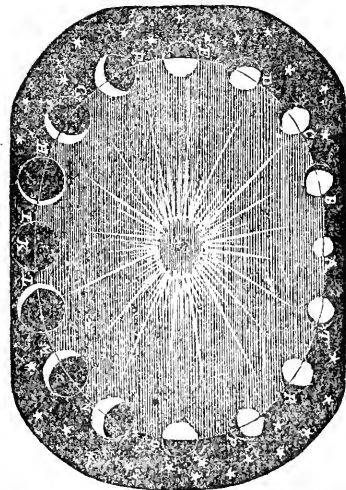

conjunction, when it presents to our view a round full face. At B it appears as an evening star, and exhibits a gibbous phase, somewhat less than

full moon. At *D* it approaches somewhat nearer to a half moon. At *E*, near the point of its eastern elongation, it appears like a half moon. During all this course it moves from west to east. From *F* to *I* it appears to move in a contrary direction, from east to west, during which it assumes the figure of a crescent, gradually diminishing in breadth, but increasing in extent, until it arrives at *I*, the point of its inferior conjunction, when its dark hemisphere is turned toward the earth, and is consequently invisible, being in a situation similar to that of the moon at the time of change. It is seen no longer in the evenings, but soon appears in the morning under the figure of a slender crescent, and passes through all the other phases represented in the diagram, at *M*, *N*, *O*, &c., until it arrives again at *A*, its superior conjunction. The earth is here supposed to be placed at *K*; and if it were at rest in that position, all the changes now stated would happen in the course of 224 days. But as the earth is moving forward in the same direction as the planet, it requires some considerable time before Venus can overtake the earth, so as to be in the same position as before with respect to the earth and the sun. The time, therefore, that intervenes between the superior conjunction and the same conjunction again, is nearly 584 days, during which period Venus passes through all the variety of its motions and phases as a morning and evening star.

This diversity of motions and phases, as formerly stated, serves to prove the truth of the system, now universally received, which places the sun in the center, and the earth beyond the orbit of Venus. In order to illustrate this point to the astronomical tyro in the most convincing manner, I have frequently used the following plan. With the aid of a planetarium, and by means of an ephemeris or a nautical almanac, I place the earth and Venus in their true positions on the planetarium, and then desire the learner to place his eye in a line with the balls representing Venus and the earth, and to mark the *phase* of Venus, as seen from the earth, whether gibbous, a half moon, or a crescent. I then adjust an equatorial telescope (if the observation be in the day-time), and, pointing it to Venus, show him this planet *with the same phase* in the heavens; an experiment which never fails to please and to produce conviction.

It has generally been asserted by astronomers that it is impossible to see Venus at the time of its superior conjunction with the sun. Mr. Benjamin Martin, in his "Gentleman and Lady's Philosophy," vol. i, says, "At and about her upper conjunction Venus cannot be seen, by reason of her nearness to the sun." And in his "Philosophia Britannica," vol. iii, the same opinion is expressed: "At her superior conjunction Venus would appear a full enlightened hemisphere, were it not that she is then lost in the sun's blaze, or hidden behind his body." Dr. Long, in his "Astronomy," vol. i, says, "Venus, in her superior conjunction, if she could be seen, would appear round like the full moon." Dr. Brewster, in the article of *Astronomy* in the "Edinburgh Encyclopædia," when describing the phases of Mercury and Venus, says, "Their luminous side is completely turned to the earth at the time of their superior conjunction, when they would appear like the full moon, if they were not then eclipsed by the rays of the sun." The same opinion is expressed in similar phrases by Ferguson, Gregory, Adams, Gravesend, and most other writers on the science of astronomy, and has been copied by all subsequent compilers of treatises on this subject. In

order to determine this point, along with several others, I commenced, in 1813, a series of observations on the celestial bodies in the *day-time*, by means of an equatorial instrument. On the 5th of June that year, a little before midday, when the sun was shining bright, I saw Venus distinctly with a magnifying power of sixty times, and a few minutes afterward with a power of thirty, and even with a power of fifteen times. At this time the planet was just  $3^{\circ}$  in longitude and about  $15'$  in time east of the sun's center, and, of course, only  $23\frac{1}{2}^{\circ}$  from the sun's limb. Cloudy weather prevented observations when Venus was nearer the sun.\* On the 16th of October, 1819, an observation was made, in which Venus was seen when only six days and nineteen hours past the time of her superior conjunction. Her distance from the sun's eastern limb was then only  $1^{\circ} 25' 42''$ . A subsequent observation proved that she could be seen when only  $1^{\circ} 27'$  from the sun's margin, which approximates to the nearest distance from the sun at which Venus is distinctly visible. About the 10th of March, 1826, I had a glimpse of this planet within a few hours of its superior conjunction, but the interposition of clouds prevented any particular or continued observations. It was then about  $1^{\circ} 25\frac{1}{2}'$  from the sun's center. Observations were likewise made to determine how near its inferior conjunction this planet might be seen. The following is the observation in which it was seen nearest to the sun. On March 11th, 1822, at thirty minutes past twelve, noon, the planet being only thirty-five hours past the point of its inferior conjunction, I perceived the crescent of Venus by means of an equatorial telescope, magnifying about seventy times. It appeared extremely slender, but distinct and well-defined, and apparently of a larger curve than that of the lunar crescent when the moon is about two days old. The difference of longitude between the sun and Venus at that time was about  $2^{\circ} 19'$ . A gentleman who happened to be present perceived the same phenomenon with the utmost ease and perfect distinctness.†

From the above observations, the following conclusions are deduced: 1. That Venus may be distinctly seen at the moment of her superior conjunction, with a moderate magnifying power, when her geocentric latitude‡ at the time of conjunction exceeds  $11\frac{1}{2}^{\circ}$ , or, at most,  $1^{\circ} 43'$ . 2. That during the space of 584 days, or about nine-

\* The particulars connected with this observation, and with those made on the other planets, and on stars of the first and second magnitudes, together with a description of the instrument, and the manner of making day observations are recorded in Nicholson's "Journal of Natural Philosophy," &c., for October, 1813, vol. xxvii, pp. 109 to 128, in a communication which occupies about twenty pages; and also, in an abridged form, in the "Monthly Magazine," "Annals of Philosophy," and other periodical journals of that period. During the succeeding winter the celebrated Mr. Playfair, professor of natural philosophy in the University of Edinburgh, communicated, in his lectures to the students, the principal details contained in that communication, as *new facts* in astronomical science.

† The observations stated above are also recorded in scientific journals. The observation of the 16th October, 1819, is recorded in the "Edinburgh Philosophical Journal," No. V, for July, 1820, pp. 191, 192; and in Dr. Brewster's second edition of "Ferguson's Astronomy," vol. ii, p. 111 in the "Monthly Magazine" for August, 1820, vol. i, p. 62. The observation of March 11, 1822, made on Venus when near the inferior conjunction, is recorded at large in the "Edinburgh Philosophical Journal," No. XIII, July, 1822, pp. 177, 178, &c.

‡ The latitude of a heavenly body is its distance from the ecliptic, or the apparent path of the sun, either north or south. Its *geocentric* latitude is its latitude as seen from the earth. Its *heliocentric* latitude is its latitude as viewed from the sun. These latitudes seldom coincide.

teen months, the time Venus takes in moving from one conjunction of the sun to a like conjunction again, when her latitude at the time of her superior conjunction exceeds  $1^{\circ} 43'$ , she may be seen by means of an equatorial telescope every clear day without interruption, except at the moment of her inferior conjunction, and a very short time before and after it, a circumstance which cannot be affirmed of any other celestial body, the sun only excepted. 3. That from the time when Venus ceases to be visible, prior to her inferior conjunction, on account of the smallness of her crescent and her proximity to the sun, to the moment when she may again be perceived in the day-time by an equatorial telescope, there elapses a period of only two days and twenty-two hours; or, in other words, Venus can never be hidden from our view about the time of her inferior conjunction for a longer period than seventy hours. 4. That during the space of 584 days, the longest period in which Venus can be hidden from our view under any circumstances, excepting a cloudy atmosphere, is about sixteen days and a half.—During the same period, this planet sometimes will be hidden from the view of a common observer for the space of five or six months.

One practical use of the above observations is, that they may lead to the determination of the difference (if any) between the polar and equatorial diameters of this planet, which point has never yet been determined. It is well known that the earth is of a spheroidal figure, having its polar shorter than its equatorial diameter. Jupiter, Mars, and Saturn have also been ascertained to be oblate spheroids and the proportion between their equatorial and polar diameters has been pretty accurately determined. As Venus is found to have a rotation round her axis, as these planets have, it is reasonable to conclude that she is of a similar figure. It is impossible, however, to determine this point when she is in those positions in which she has generally been viewed; as at such times she assumes either a gibbous phase, the form of a half moon, or that of a crescent, in neither of which cases can the two diameters be measured. I am therefore of opinion that, at some future conjunction, when her geocentric latitude is considerable, with a telescope of a high magnifying power, furnished with a micrometer, this point might be ascertained. If the planet is then viewed at a high latitude, and the sky serene, its disc will appear sufficiently luminous and well-defined for this purpose; free of that glare and tremulous aspect it generally exhibits when near the horizon, which makes it appear larger than it ought to do, and prevents its margin from being accurately distinguished.

Such observations require a considerable degree of attention and care, and various contrivances for occasionally diminishing the aperture of the object-glass, and for preventing the direct rays of the sun from entering the tube of the telescope. In order to view this planet to advantage at any future conjunction, when in *south* latitude, it will be proper to fix a board, or any other thin opaque substance, at a considerable distance beyond the object end of the telescope, having such a degree of concave curvature as shall nearly correspond with a segment of the diurnal arc at  $t$  at time described by the sun, with its lower concave edge at an elevation a small degree above the line of collimation of the telescope, when adjusted for viewing the planet, in order to intercept as much as possible the solar rays. When the planet is in *north* latitude, the curvature of the board must be made *convex*, and placed a little below the line of sight.

Fig. 13

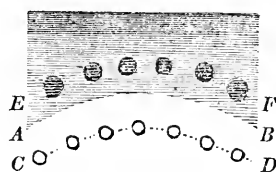

The above figure will illustrate my idea; where  $A B$  (Fig. 13) represents the concave curve of the board to be used when the planet is in *south* latitude;  $C D$ , a segment of the apparent diurnal path of the planet; and  $E F$ , a segment of the sun's diurnal arc. Fig. 14, represents the board

Fig. 14.

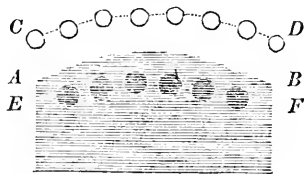

to be used when the planet is in *north* latitude, which requires no further description. I have given the above brief statement of the observations on Venus because they are not yet generally known, and because compilers of elementary books on astronomy still reiterate the vague and unfounded assertion that it is impossible to see this planet at its superior conjunction, when it presents a full enlightened hemisphere. The circumstance now ascertained may not be considered as a fact of much importance in astronomy. It is always useful, however, in every department of science, to ascertain every fact connected with its principles, however circumstantial and minute, as it tends to give precision to its language; as it enables the mind to take into view every particular which has the least bearing on any object of investigation; and as it may ultimately promote its progress by leading to conclusions which were not at first apprehended. One of these conclusions or practical uses has been stated above; and another conclusion is, that such observations as now referred to may possibly lead to the discovery of planets yet unknown within the orbit of Mercury, which circumstance I shall take occasion more particularly to explain in the sequel.

*Discoveries made by the Telescope in relation to Venus.*—The first circumstance which attracted the attention of astronomers after the invention of the telescope, was, the variety of phases which Venus appeared to assume, of which I have already given a description. Nothing further was observed to distinguish this planet until more than half a century had elapsed, when Cassini, a celebrated French astronomer, in the years 1666–7, discovered some spots on its surface, by which he endeavored to ascertain the period of its revolution round its axis. October 14th, 1666, at five hours forty-five minutes, *p. m.*, he saw a bright spot near the limits between the light and the dark side of the planet, not far from its center; at the same time he noticed two dark oblong spots near the west side of the disc, as represented in Fig. 15. After this he could obtain no satisfactory views of Venus until April 20th, 1667, about fifteen minutes before sunrise, when he saw upon the disc, now half enlightened, a bright part, distant from the southern edge about a

fourth part of the diameter of the disc, and near the eastern edge. He saw, likewise, a darkish oblong spot toward the northern edge, as in Fig. 15. At sunrise he perceived that the bright part

Fig. 15.

Fig. 16.

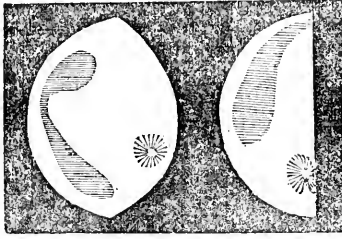

was advanced farther from the southern point than when he first observed it, as at Fig. 17, when he had the satisfaction of finding an evident proof of the planet's motion. On the next day, at sunrise, the bright spot was a good way off the section, and distant from the southern point a fourth part of the diameter of the disc. When the sun had risen six degrees above the horizon, the spot had got beyond the center. When the sun had risen seven degrees, the section cut it in halves, as in Fig. 18, which showed its motion to have some inclination toward the center.\* Several ob-

Fig. 17.

Fig. 18.

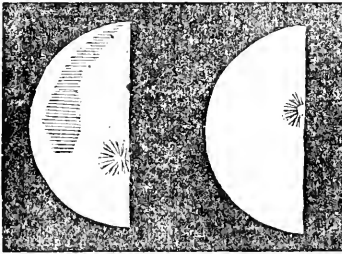

servations of a similar kind were made about that time, which led Cassini to the conclusion that the planet revolves about its axis in a period somewhat more than twenty-three hours. From this time, for nearly sixty years, we have no further accounts of spots having been observed on the disc of Venus.

In the year 1726, *Bianchini*, with telescopes of 90 and 100 Roman palms, commenced a series of observations on Venus, and published an account of them in a book entitled, "*Hesperii et Phosphorici nova Phenomena*." In these observations, we do not find that any one of them was continued long enough to discover any change of position in the spots at the end of the observation from what there was at the beginning; but at the distance of two and of four days he found the same spot advanced so far that he concluded it must have gone round at the rate of  $15^\circ$  in a day. This advance would show that Venus turned round either once in about twenty-four days, or in little more than twenty-three hours, but would not determine which of these was the true period. For, if an observer, at a given hour, suppose seven in the evening, were to mark the exact place of a spot, and at the same hour on the next day find the spot advanced  $15^\circ$ , he would not be able to determine

whether the spot, during that interval of twenty-four hours, had advanced forward only  $15^\circ$ , or had finished a revolution, and  $15^\circ$  more as a part of another rotation.\* Of these two periods, *Bianchini* concluded that the rotation was accomplished in twenty-four days eight hours. The following is the chief, if not the only observation, he brings forward to substantiate his conclusion. He saw three spots, *A*, *B*, *C*, in the situation represented in Fig. 19, which he and several persons of distinction viewed for about an hour

Fig. 19.

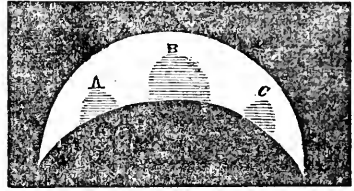

when they could discover no change of place in their appearance. Venus being hidden behind the *Barbarini* palace, their view was interrupted for nearly three hours, at the end of which they found that the spots had not sensibly changed their situation. But the inference from this observation is not conclusive for the period of twenty-four days eight hours. For, during the three hours' interruption, the spot *C* might have gone off the disc, and the spot *B* moved into its place, where, being near the edge, it would appear less than when in the middle. *A*, succeeding into the place of *B*, would appear larger than it did near the edge, and another spot might have come into the place of *A*. For that there were other spots, particularly one which, by the rotation of Venus, would have been brought into the place of *A*, appears by the figures given by *Bianchini*; and if so, it would correspond with the rotation of twenty-three hours twenty minutes deduced by *Cassini*. Beside, it is impossible to make observations on Venus for three or four hours in succession, as is here supposed, without the help of equatorial instruments, which were not then in use, as this planet is seldom more than three hours above the horizon after sunset; and when it descends within  $8^\circ$  or  $10^\circ$  of the horizon, it is impossible to see its surface with any degree of distinctness, on account of the brilliancy of its light, and the undulating vapors near the horizon, which, in some cases, prevent even its phase from being accurately distinguished. In the communication in "*Nicholson's Journal*" for 1813, already referred to, I have shown how the dispute in reference to the rotation of Venus may be settled, by commencing a series of observations on this planet in the day-time, when its spots, if any were perceived, could be traced in their motion for twelve hours or more. *Mr. Ferguson*, in his astronomy, by adopting the conclusion of *Bianchini*, has occupied a number of pages in describing the phenomena of Venus on this supposition, which description is altogether useless, and conveys erroneous ideas of the circumstances connected with this planet, if the period determined by *Cassini* (as is most probable) be correct. *Mr. Schroeter*, formerly mentioned, who has been a most diligent and accurate observer of the heavens, commenced a series of observations, in order to determine the daily period of this planet

\* See "Philosophical Transactions," abridged by *Drs. Hutton, Shaw, and Pearson*, vol. 1, part 2, p. 217; "*Journal des Savans*," vol. 1, p. 216; and "*Memoires of the Royal Academy of Sciences*."

\* See some particular remarks on this subject, illustrated with a figure, in my volume "On the Improvement of Society," section 3.

He observed particularly the different shapes of the two horns of Venus. Their appearance generally varied in a few hours, and became nearly the same at the corresponding time of the subsequent day, or, rather, about half an hour sooner every day. Hence he concluded that the period must be about twenty-three hours and a half; that the equator of the planet is considerably inclined to the ecliptic, and its pole at a considerable distance from the point of the horn. From several observations of this kind he found that the period of rotation must be twenty-three hours, twenty-one minutes, or only one minute more than had been assigned by Cassini; and this, we have reason to believe, is about the true period of this planet's revolution round its axis, being thirty-five minutes less than the period of the earth's rotation, which is twenty-three hours fifty-six minutes. I have stated these observations respecting the rotation of Venus at some length, because they are not generally known to common readers on this subject, or noticed in modern elementary books on astronomy, and that the general reader may perceive the reason of the dispute which has arisen among astronomers on this point.

**Mountains on Venus.**—Mr. Schroeter, in his observations, discovered several mountains on this planet, and found that, like those of the moon, they were always highest in the southern hemisphere; their perpendicular heights being nearly as the diameters of their respective planets. From the 11th of December, 1789, to the 11th of January, 1790, the southern horn, *b* (Fig. 20), appeared much blunted, with an enlightened mountain,

Fig. 20.

Fig. 21

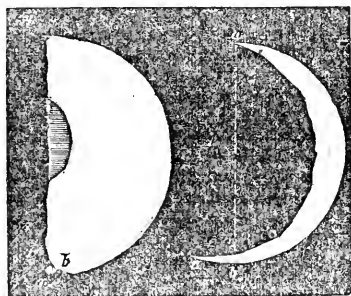

*m.* in the dark hemisphere, which he estimated at about 18,300 toises, or nearly twenty-two miles in perpendicular height. It is quite obvious that if such a bright spot as here represented was regularly or periodically seen, it must indicate a very high elevation on the surface of the planet, and its precise height will depend upon its distance from the illuminated portion of the disc, or, in other words, the length of its shadow. It is precisely in such a way that the mountains in the moon are distinguished. Mr. Schroeter measured the altitude of other three mountains, and obtained the following results: height of the first, nineteen miles, or about five times the height of Chimborazo; height of the second, eleven miles and a half; and of the third, ten miles and three quarters. These estimates may, perhaps, require certain corrections in future observations.

**Atmosphere of Venus.**—From several of Mr. Schroeter's observations, he concludes that Venus has an atmosphere of considerable extent. On the 10th of September, 1791, he observed that the southern cusp of Venus disappeared, and was bent like a hook about eight seconds beyond the luminous semicircle into the dark hemisphere. The

northern cusp had the same tapering termination, but did not encroach upon the dark part of the disc. A streak, however, of glimmering bluish light proceeded about eight seconds along the dark line, from the point of the cusp, from *b* to *c* (Fig. 21), *b* being the extremity of the diameter of *a b*, and consequently, the natural termination of the cusp. The streak *b c*, verging to a pale gray, was faint when compared with the light of the cusp at *b*. I was struck with a similar appearance when observing Venus, when only thirty-five hours past her inferior conjunction, on March 11, 1822, as formerly noticed (p. 12). One of the cusps, at least, appeared to project into the dark hemisphere, like a fine lucid thread, beyond the luminous semicircle. This phenomenon Mr. Schroeter considers as the twilight, or crepuscular light of Venus. From these and various other observations, which it would be too tedious to detail, he concludes, on the ground of various calculations, that the dense part of the atmosphere of Venus is about 16,020 feet, or somewhat above three miles high; that it must rise far above the highest mountains; that it is more opaque than that of the moon; and that its density is a sufficient reason why we do not discover on the surface of Venus those superficial shades and varieties of appearance which are to be seen on the other planets.

**Day Observations on Venus.**—The most distinct and satisfactory views I have ever obtained of this planet were taken at noonday, or between the hours of ten in the morning and two in the afternoon, when it happened to be at a high elevation above the horizon, which is generally the case during the summer months. The light of this planet is so brilliant, that its surface and margin seldom appear well-defined in the evening, even with the best telescopes. But in the day-time its disc and margin present a sharp and well-defined aspect with a good achromatic telescope, and almost completely free of those undulations which obscure its surface when near the horizon. The following figure (No. 1) represents one of the appearances of Venus which I have frequently seen in the day-time when viewing this planet at a high altitude and in a serene sky, when near the meridian, by means of a three-and-a-half feet achromatic telescope, magnifying about 150 times.

Fig. 22.

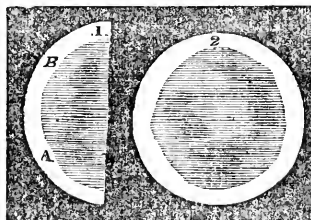

The exterior curve of the planet, as here exhibited, appeared far more lucid and bright than the interior portion. It was not a mere stripe or luminous margin, but a broad semicircle, of a breadth nearly one-third of the semidiameter of the planet. It appeared as if it were a kind of table-land, or a more elevated portion of the planet's surface, while the interior and darker part appeared more like a plain, diversified with inequalities, and two large spots, somewhat darker than the other parts, were faintly marked. The appearance was somewhat similar to that of certain portions of the level parts of the moon which lie adjacent to a ridge of mountains or a range of

elevated ground. I have exhibited this view of Venus at different times to various individuals, and even those not accustomed to look through telescopes could plainly perceive it. I consider it as a corroboration of the fact, that mountains of great elevation exist on the surface of this planet. There appeared likewise some slight indentations in the boundary which separated the dark from the enlightened hemisphere, which circumstance leads to the same conclusions. If the whole hemisphere of the planet had been enlightened, it would probably have appeared as in No. 2. On the whole, I am of opinion that future discoveries in relation to Venus will be chiefly made in the day-time, by large telescopes adapted to equatorial machinery, when such instruments shall be brought into use more than they have hitherto been. Venus, however, is the only planet on which useful observations can be made in the day-time; for although several of the other planets can be perceived, even at noonday, particularly Jupiter, yet they present a very obscure and cloudy appearance compared with Venus, on account of the comparatively small quantity of solar light which falls upon their surfaces.

*Supposed Satellite of Venus.*—Several astronomers have been of opinion that Venus is attended with a satellite, although it is seldom to be seen. It may not be improper to give the reader an abridged view of the observations on which this opinion is founded, that he may be able to judge for himself. The celebrated Cassini, who discovered the rotation of Mars, Jupiter, and Venus, and four of the satellites of Saturn, was the first who broached this opinion. The following is his account of the observations on which it is founded:

"16:6, August 18, at fifteen minutes past four in the morning, looking at Venus with a telescope of thirty-four feet, I saw at the distance of three-fifths of her diameter, eastward, a luminous appearance, of a shape not well-defined, that seemed to have the same phase with Venus, which was then gibbous on the western side. The diameter of this phenomenon was nearly equal to a fourth part of the diameter of Venus. I observed it attentively for a quarter of an hour, and having left off looking at it for four or five minutes, I saw it no more; but daylight was then advanced. I had seen a like phenomenon, which resembled the phase of Venus, on January 25, 1672, from fifty-two minutes after six in the morning to two minutes after seven, when the brightness of the twilight caused it to disappear. Venus was then horned, and this phenomenon, the diameter of which was nearly a fourth part of the diameter of Venus, was of the same shape. It was distant from the southern horn of Venus, a diameter of Venus on the western side. In these two observations I was in doubt whether it was not a satellite of Venus, of such a consistence as not to be very well fitted to reflect the light of the sun, and which, in magnitude, bore nearly the same proportion to Venus as the moon does to the earth, being at the same distance from the sun and the earth as Venus was, the phases of which it resembled."

In the year 1740, October 23, at sunrise, Mr. Short, with a reflecting telescope of sixteen inches and a half, which magnified about sixty times, perceived a small star at the distance of about ten seconds from Venus; and, putting on a magnifying power of 240 times, he found the star put on the phase of Venus. He tried another magnifying power of 140 times, and even then found the star to have the same phase. Its diameter seemed

about a third of the diameter of Venus. Its light was not so bright or vivid, but exceedingly sharp and well-defined. A line passing through the center of Venus and it made an angle with the equator of about twenty degrees. He saw it, for the space of an hour, several times that morning; but, the light of the sun increasing, he lost it about a quarter of an hour after eight. He says he looked for it every clear morning after this, but never saw it again.\*

A similar phenomenon is described as having been seen by Baudouin, Montaigne, Rodkier, Montbarron, and other astronomers, and, from their observations, the celebrated M. Lambert, in the "Memoirs of the Academy of Berlin" for 1773, gave a theory of the satellite of Venus, in which he concludes that its period is eleven days, five hours, and thirteen minutes; the inclination of its orbit to the ecliptic,  $63^{\circ} 34'$ ; its distance from Venus,  $66\frac{1}{2}$  radii of that planet; and its magnitude,  $4-27$  of that of Venus, or nearly equal to that of our moon. There is a singular consistency in these observations, which it is difficult to account for if Venus have no satellite. Astronomers expected that such a body, if it existed, would be seen as a small dark spot upon the sun at the time of the transits of Venus in 1761 and 1769; but no such phenomenon seems to have been noticed at those times by any of the observers. Lambert, however, maintains, from the tables he calculated in relation to this body, that the satellite, if it did exist, might not have passed over the sun's disc at the time of the transits, but he expected that it might be seen alone on the sun when Venus passed near that luminary.

The following is a particular account of the observations made by Mr. Montaigne:—May 3, 1761, he perceived, at twenty minutes distance from Venus, a small crescent, with the horns pointing the same way as those of Venus. Its diameter was a fourth of that of its primary; and a line drawn from Venus to the satellite made, below Venus, an angle with the vertical of about twenty degrees toward the south, as in Fig. 22. No. 3, where *Z N* represents the vertical, and *E C* a parallel to the ecliptic, making then an angle with the vertical of forty-five degrees. The

Fig. 22.—No. 3.

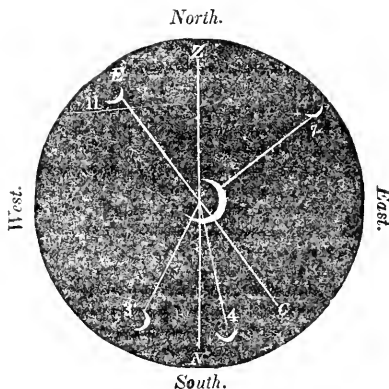

numbers 3, 4, 7, 11, mark the situations of the satellite on the respective days. May 4th, at the same hour, he saw the same star, distant from Venus about one minute more than before, and

\* "Philosophical Transactions," No. 459, for January February and March, 1741.



making an angle with the vertical of ten degrees below, but on the north side; so that the satellite seemed to have described an arc of about thirty degrees, whereof Venus was the center, and the radius twenty minutes. The two following nights being hazy, Venus could not be seen. But May 7th, at the same hour as on the preceding days, he saw the satellite again, but above Venus, and on the north side, as represented at 7, between twenty-five and twenty-six minutes, upon a line which made an angle of forty-five degrees with the vertical toward the right hand. It appears by the figure that the points 3 and 7 would have been diametrically opposite if the satellite had gone fifteen degrees more round the central point where Venus is represented. May 11th, at nine o'clock, P. M., the only night when the view of the planet was not obscured by moonlight, twilight, or clouds, the satellite appeared nearly at the same distance from Venus as before, making, with the vertical, an angle of forty-five degrees toward the south, and above its primary. The light of the satellite was always very weak; but it had always the same phase with its primary, whether viewed with it in the field of the telescope or alone by itself. He imagined that the reason why the satellite had been so frequently looked for without success might be, that one part of its globe was crusted over with spots, or otherwise unfit to reflect the light of the sun with any degree of brilliancy, as is supposed to be the case with the fifth satellite of Saturn.

It is evident that, if Venus has a satellite, it must be difficult to be seen, and can only be perceived in certain favorable positions. It cannot be seen when nearly the whole of its enlightened hemisphere is turned to the earth, on account of its great distance at such a time, and its proximity to the sun; nor could it be expected to be seen when the planet is near its inferior conjunction, as it would then present to the earth only a very slender crescent, beside being in the immediate neighborhood of the sun. The best position in which such a body might be detected is near the time of the planet's greatest elongation, and when it would appear about half enlightened. If the plane of its orbit be nearly coincident with the plane of the planet's orbit, it will be frequently hidden by the interposition of the body of Venus, and likewise when passing along her surface in the opposite point of its orbit; and if one side of this body be unfitted for reflecting much light, it will account in part for its being seldom seen. It is not sufficient in this case, to say, as Sir David Brewster has done, "that Mr. Wargentin had in his possession a good achromatic telescope, which always showed Venus with such a satellite, and that the deception was discovered by turning the telescope about its axis." For we cannot suppose that such accurate observers as those mentioned above would have been deceived by such an optical illusion; and, beside, the telescopes which were used in the observations alluded to were both refractors and reflectors, and it is not likely that both kinds of instruments would produce an illusion, especially when three different powers were applied, as in Mr. Short's observations. Were the attention of astronomers more particularly directed to this point than it has hitherto been; were the number of astronomical observers increased to a much greater degree than at present; and were frequent observations on this planet made in the clear and serene sky of tropical climates, it is not improbable that a decisive opinion might soon be formed on this point; and, if a satellite were detected, it would tend to pro-

mote the progress and illustrate the deductions of physical astronomy. It is somewhat probable, reasoning *a priori*, that Venus, a planet nearly as large as the earth, and in its immediate neighborhood, is accompanied by a secondary attendant.

*Transits of Venus.*—This planet, when in certain positions, is seen to pass like a round black spot across the disc of the sun. These *transits*, as they are called, are of rare occurrence, and take place at intervals of 8 and 113 years. If the plane of the orbit of Venus exactly coincided with that of the earth, a transit would happen at regular intervals of little more than nineteen months; but as one-half of this planet's orbit is three degrees and a half below the plane of the earth's orbit, and the other half as much above it, a transit can only take place when it happens to be in one of the *nodes*, or intersections of the orbits, about the time of its inferior conjunction. These transits of Venus are phenomena of very great importance in astronomy, as it is owing to the observations which have been made on them, and the calculations founded on these observations, that the distance of the sun has been very nearly ascertained, and the dimensions of the planetary system determined to a near approximation to the truth. It would be too tedious to enter into a particular explanation of the process and calculations connected with this subject, and, therefore, I shall only, in a few words, explain the *principle* on which the deductions are founded. Suppose *B A* (Fig. 23) to represent the earth; *v*, Venus; and *S* the sun. Suppose two spectators, *A* and *B*, at opposite extremities of that diameter of the earth which is perpendicular to

Fig. 23.

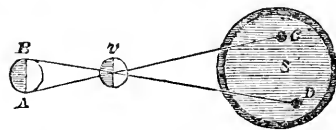

the ecliptic; then, at the moment when the observer at *B* sees the center of the planet projected at *D*, the observer at *A* will see it projected at *C*. If, then, the two observers can mark the precise position of Venus on the sun's disc at any given moment, or note the precise time of ingress or egress of the planet, the angular measure of *C D*, as seen from the earth, might be ascertained. Since *A C* and *B D* are straight lines crossing each other at *v*, they consequently make equal angles on each side of the point *v*; and *C D* will be to *B A* as the distance of Venus from the sun is to her distance from the earth; that is, as 68 to 27, or nearly as  $2\frac{1}{2}$  to 1; for Venus is 68 millions of miles from the sun, and 27 millions from the earth, at the time of a transit or an inferior conjunction. *C D*, therefore, occupies a space on the sun's disc  $2\frac{1}{2}$  times as great as the earth's apparent diameter at the distance of the sun, or, in other words, it is equal to *five times* the sun's horizontal parallax; and, therefore, any error that might occur in measuring it will amount to only one-fifth of that error on the horizontal parallax that may be deduced from it; and it is on the ground of this parallax that the distance of the sun is determined. The result of all the observations made on the transits which happened in 1761 and 1769, gives about  $8\frac{1}{2}$  seconds as the horizontal parallax of the sun, which makes his distance 95 millions of miles. The distance is considered by the most enlightened astronomers as within *one-fiftieth* part of the true distance of

the sun from the earth; so that no future observations will alter this distance so as to increase or diminish it by more than two millions of miles.

The future transits of Venus for the next 400 years are as follows:

	Hours.	Minutes.
1874, December 9th.....	4	8 A. M.
1882, December 6th.....	4	16 P. M.
2004, June 8th.....	8	51 A. M.
2012, June 6th.....	1	17 A. M.
2117, December 11th.....	2	57 A. M.
2125, December 8th.....	3	9 P. M.
2247, June 11th.....	0	21 P. M.
2255, June 9th.....	4	44 A. M.

Some of these transits will last nearly seven hours. The next two transits will not be visible throughout their whole duration in Britain or in most countries in Europe. Such was the importance attached to the observations of the last transits, in 1761 and 1769, that several of the European states fitted out expeditions to different parts of the world, and sent astronomers with them, to make the requisite observations. This was one end, among others, of the celebrated expedition of Captain Cook, in 1769, to the islands of the Pacific Ocean; and the transit was observed in *Takiti*, now so celebrated on account of the moral revolution which has lately taken place among its inhabitants.

*Magnitude and Extent of Surface on this Planet.*  
—The diameter of Venus has been computed at about 7800 miles; and, consequently, its surface contains 191,134,944, or above 191 millions of square miles. Taking, as formerly, the population of England as a standard, this planet would contain a number of inhabitants equal to more than 53,500 millions, or nearly sixty-seven times the population of our globe. It does not appear that any great quantity of water exists upon this planet, otherwise there would be a greater contrast between the different parts of its surface, the water presenting a much darker hue than the land. For, if from a high mountain we survey a scene in which a portion of a large river or of the ocean is contained, when the sun is shining on all the objects, we shall find that the water presents a much darker appearance than the land, as it absorbs the greater part of the rays of light, except in a few points between our eyes and the sun, where his rays are reflected from the surface of the fluid; but these partial reflections would be altogether invisible at the distance of the nearest planet. It is pretty evident, however, from what has been formerly stated, that there is a great diversity of surface on this planet; and if some of its mountains be more than twenty miles in elevation, they may present to view objects of sublimity and grandeur, and from their summits extensive and diversified prospects of which we can form no adequate conception. So that Venus, although a small fraction smaller than the earth, may hold a rank in the solar system, and in the empire of the Almighty, in point of population and sublimity of scenery, far surpassing that of the world in which we dwell.

Having dwelt so long on the phenomena of this planet, I shall state only the following additional particulars: The *quantity of light* on Venus is nearly twice as great as that on the earth, which will, doubtless, have the effect of causing all the colors reflected from the different parts of the scenery of that planet to present a more vivid, rich, and magnificent appearance than with us. It is probable, too, that a great proportion of the objects on its surface are fitted to reflect the solar

rays with peculiar splendor; for its light is so intense as to be distinctly seen by telescopes in the day-time; and, during night, the eye is so overpowered by its brilliancy as to prevent its surface and margin from being distinctly perceived. Were we to indulge our imaginations on this subject, this circumstance might lead us to form various conceptions of the glory and magnificence of the diversified objects which may be presented to the view of the intellectual beings who inhabit this world; but, in the meantime, we have no sufficient *data* to warrant us in indulging in conjectural speculations. The apparent size of the sun as seen from Venus, compared with his magnitude as seen from the earth, is represented in fig. 24, the larger circle showing the size of the sun from Venus.

Fig. 24.

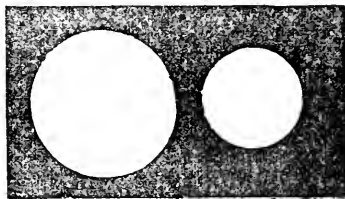

With regard to the *heat* in this planet, according to the principles and facts formerly stated (page 28), it may be modified by the constitution of its atmosphere and the nature of the substances which compose its surface, so that its intensity may not be so great as we might imagine from its nearness to the sun. Even on the supposition that the intensity of the heat of any body is inversely as the square of its distance from the sun, it has been calculated that the greatest heat in Venus exceeds the heat of St. Thomas, on the coast of Guinea, or of Sumatra, about as much as the heat in those places exceeds that of the Orkney Islands or that of the city of Stockholm; and, therefore, at 60 degrees north latitude on that planet, if its axis were perpendicular to the plane of its orbit, the heat would not exceed the greatest heat of the earth, and, of course, vegetation like ours could be carried on, and animals of a terrestrial species might subsist. But we have no need to enter into such calculations in order to prove the habitability of Venus, since the Creator has, doubtless, in this as well as in every other case, adapted the structure of the inhabitant, to the nature of the habitation.

In addition to the above, the following facts may be stated: Venus revolves in an orbit which is 433,800,000 of miles in circumference in the space of 224 days 16 hours; its rate of motion is therefore about eighty thousand miles every hour; one thousand three hundred and thirty miles every minute, and above twenty-two miles every second. Its distance from the sun is 68 millions of miles; and its distance from the earth, when nearest us, is about 27 millions of miles, which is the nearest approach that any of the heavenly bodies (except the moon) make to the earth. Yet this distance, when considered by itself, is very great; for it would require a cannon ball six years and three months to move from the earth to the nearest point of the orbit of Venus, although it were flying every moment at the rate of 500 miles an hour, or 12,500 miles a day. Were the enlightened hemisphere of the planet turned to the earth when it is in this nearest point of its orbit, it would appear like a brilliant moon, twenty-five times larger than it generally does to the naked

eye; but at that time its light side is turned to the sun and away from the earth. At its greatest distance from us it is 163 millions of miles from the earth. The period of its *greatest brightness* is when it is about forty degrees from the sun, either before or after its inferior conjunction, at which time there is only about *one-fourth* part of its disc that appears enlightened. In this position it may sometimes be seen with the naked eye even amid the splendors of noonday. In the evening it casts a distinct shadow on a horizontal plane. Sir John Herschel remarks, that this shadow, to be distinguished, "must be thrown upon a white ground. An open window in a whitewashed room is the best exposure; in this situation I have observed not only the shadow, but the diffracted fringes edging its outline." The *density* of Venus compared with that of the sun is as 1 to 383,137, according to La Place's calculations, while that of the earth is as 1 to 329,630; so that the earth is somewhat denser than Venus. A body weighing one pound on the earth will weigh only 15 oz. 10 dr. on the surface of Venus. The *eccentricity* of the orbit of Venus is less than that of any of the other planets; it amounts to 492,000 miles, which is only the 1-276th part of the diameter of its orbit, which, consequently, approaches very nearly to a circle. The inclination of its orbit to the ecliptic is  $3^{\circ} 23' 33''$ . Its mean apparent diameter is 17", and its greatest about  $57\frac{1}{2}''$ . Its greatest elongation from the sun varies from  $45^{\circ}$  to  $47^{\circ} 12'$ . Its mean arc of *retrogradation*, or when it moves from east to west, contrary to the order of the signs, is  $16^{\circ} 12'$ , and its mean duration forty-two days, commencing or ending when it is about  $26^{\circ} 48'$  distant from the sun. Such is a condensed view of most of the facts in relation to Venus which may be considered as interesting to the general reader.

### III. OF THE EARTH, CONSIDERED AS A PLANET.

In exhibiting the scenery of the heavens, it is not perhaps absolutely necessary to enter into any particular description of the earth; but as it is the only planetary body with which we are intimately acquainted, and the only standard by which we can form a judgment of the other planetary globes, and as it is connected with them in the same system, it may be expedient to state a few facts in relation to its figure, motion, structure, and general arrangements.

The earth, though apparently a quiescent body in the center of the heavens, is suspended in empty space, surrounded on all sides by the celestial luminaries and the spaces of the firmament. Though it appears to our view to occupy a space larger than all the heavenly orbs, yet it is, in fact, almost infinitely smaller, and holds a rank only with the smaller bodies of the universe; and, although it appears to the eye of sense immovably fixed in the same position, yet it is, in reality, flying through the ethereal spaces at the rate of more than a thousand miles every minute, as we have already demonstrated. The *figure* of the earth is now ascertained to be that of an oblate spheroid, very nearly approaching to the figure of a globe. An orange and a common turnip are oblate spheroids, and are frequently exhibited to illustrate the figure of the earth. But they tend to convey an erroneous idea; for, although a spheroid of ten feet diameter were constructed to exhibit the true figure of the earth, no eye could distinguish the difference between such a spheroid and a perfect globe, since the difference of its two diameters would scarcely exceed one-third of an

inch; whereas, if its diameters bore the same proportion to each other as the two diameters of an orange generally do, its polar diameter would be nearly one foot three inches shorter than its equatorial.

Before the time of Newton, it was never suspected that the figure of the earth differed in any degree from that of a perfect sphere, excepting the small inequalities produced by the mountains and vales. The first circumstance which led to the determination of its true figure was an accidental experiment made with a pendulum near the equator. M. Richer, a Frenchman, in a voyage made to Cayenne, which lies near the equator, found that the pendulum of his clock no longer made its vibrations so frequently as in the latitude of Paris, and that it was absolutely necessary to shorten it in order to make it agree with the times of the stars passing the meridian. Some years after this, Messrs. Deshayes and Varin, who were sent by the French king to make certain astronomical observations near the equator, found that the pendulum at Cayenne made 148 vibrations less in a day than at Paris, and that his clock was retarded by that means two minutes twenty-eight seconds; and was obliged to make his pendulum shorter by two lines, or the sixth part of a Paris inch, in order to make the time agree with that deduced from celestial observations. Similar experiments, attended with the same results, were made at Martinique, St. Domingo, St. Helena, Goree, on the coast of Africa, and various other places, in all which it was found that the alteration was the greatest under the equator, and that it diminished as the observer approached the northern latitudes. This discovery, trifling as it may at first sight appear, opened a new field of investigation to philosophic minds; and there are, perhaps, few facts throughout the range of science from which so many curious and important facts have been deduced. Sir Isaac Newton and M. Huygens were among the first who perceived the extensive application of this discovery, and the important results to which it might lead. Newton, whose penetrating eye, traced the fact through all its bearings and remote consequences, at once perceived that the earth must have some other figure than what was commonly supposed, and demonstrated that this diminution of weight naturally arises from the earth's rotation round its axis, which, according to the laws of circular motion, repels all heavy bodies from the axis of motion; so that, this motion being swifter at the equator than in other parts more remote, the weight of bodies must also be less there than near the poles. All heavy bodies, when left to themselves, fall toward the earth in lines perpendicular to the horizon; and, were those lines continued, they would all pass through the earth's center. Every part of the earth, therefore, gravitates toward the center; and as this force is found to be about 289 times greater than that which arises from the rotation of the earth, a certain balance will constantly be maintained between them, and the earth will assume such a figure as would naturally result from the difference of these two opposite forces. From various considerations and circumstances of this kind, Newton founded his sublime calculations on this subject; and, as Fontenelle remarks, "determined the true figure of the earth without leaving his elbow-chair."

Newton and Huygens were both engaged in these investigations at the same time, unknown to each other, but the results of their calculations were nearly alike. They demonstrated, from the

known laws of gravitation, that the true figure of the earth was that of an oblate spheroid, flattened at the poles, and protuberant at the equator; that the proportion between its polar and equatorial diameters is as 229 to 230, and consequently, that the polar diameter is shorter than the equatorial by about thirty-four miles.\* If these deductions be nearly correct, it follows that a degree of latitude in the polar regions must measure more than a degree near the equator. To determine this point by actual measurement, it was ordered by the French King that a degree should be measured both at the equator and within the polar circle. Messrs. Maupertuis, Clairaut, and others were sent to the north of Europe, and Messrs. Bouguer, Godin, and La Condamine to Peru, in South America. The first of these companies began their operations at Tornea, near the Gulf of Bothnia, in July, 1736, and finished them in June, 1737. Those who were sent to Peru, having greater difficulties to encounter, did not finish their survey until the year 1741. The results of these measurements were, that a degree of the meridian in Lapland contains 344,627 French feet, and a degree of the meridian at the equator 340,606; so that a degree in Lapland is 4021 French feet, or 4280 English feet, longer than a degree at the equator; that is, they differ about six and a half English furlongs, or 8-16ths of a mile. But if the earth had been a perfect sphere, a degree of the meridian in every latitude would have been found precisely of the same length. This spheroidal figure is not peculiar to the earth; for the planets Saturn, Jupiter, and Mars are likewise found to be spheroids, and some of them much flatter at the poles than the earth. The difference between the polar and equatorial diameters of Jupiter is more than 6000 miles.

From the circumstances stated above, we may learn that the most minute facts connected with the system of nature ought to be carefully observed, investigated, and recorded, as they may lead to important conclusions, which, at first view, we may be unable to trace or to appreciate; for in the system of the material world, the greatest and most sublime effects are sometimes produced from apparently simple and even trivial causes. Who could have imagined that such a simple circumstance as the retardation of clocks in southern climes, and the shortening or lengthening of a pendulum, would lead to such an important discovery as the spheroidal figure of the earth? Hence we may conclude, that if ten thousands of rational observers of the facts of nature were to be added to those who now exist, many parts of the scenery of the universe which are now involved in darkness and mystery might ere long be unfolded to our view.

*General Aspect of the Earth's Surface.*—The most prominent and distinguishing feature of the surface of our globe is the two bands of land and of water into which it is divided. These bands present a somewhat irregular appearance and form, but their greatest length is from north to south. One of these bands of land, generally denominated the eastern continent, comprehends Europe, Africa, and Asia, and extends from the Cape of Good Hope on the south to the north-eastern extremity of Kamtschatka, in which direction its length measures about 10,000 miles.—Its greatest breadth from Corea, or the eastern

parts of Chinese Tartary, to the western extremity of Africa, is about 9000 miles. The other band of earth is the western continent, comprehending North and South America, lying between the Atlantic on the east and the Pacific Ocean on the west. Its greatest length is about 8000 miles from north to south, and its greatest breadth, from Nootka Sound to Newfoundland, North America, and from Cape Blanco to St. Roque, South America, is about 5000 miles. Beside these two larger bands of land, there is the large island of New Holland, which is 2600 miles long and 2000 broad, which might be reckoned a third continent; along with many thousands of islands, of every form and size, which are scattered throughout the different seas and oceans. The whole of these solid parts of our globe comprehends an area of about forty-nine millions of square miles, or about one-fourth of the superficies of the terraqueous globe, which contains about one hundred and ninety-seven millions of square miles. Were all these portions of the land peopled with inhabitants in the same proportion as in England, the population of the globe would amount to thirteen thousand seven hundred and twenty millions of human beings, which is more than *seventeen* times its present number of inhabitants. Yet, strange to tell, this world has, in all ages, been the scene of wars, bloodshed, and contests for small patches of territory, although the one-seventeenth part of it is not yet inhabited!

There is a striking correspondence between two sides of the two continents to which we have adverted, the prominent parts of the one corresponding to the indentings of the other. If we look at a terrestrial globe or map of the world, we shall perceive that the projection of the western coast of Africa nearly corresponds with the opening between North and South America, opposite to the Gulf of Mexico; that the projection in South America, about Cape St. Roque and St. Salvador, nearly corresponds with the opening in the Gulf of Guinea; so that, if we could conceive the two continents brought into contact, the openings to which I have referred would be nearly filled up, so as to form one compact continent. The Gulf of Guinea would be nearly blocked up with the eastern coast of South America, and a large gulf formed between Brazil and the land to the eastward of the Cape of Good Hope. The Gulf of Mexico would be formed into a kind of inland lake, and Nova Scotia and Newfoundland would block up a portion of the Bay of Biscay and the English Channel, while Great Britain and Ireland would block up the entrance to Davis's Straits. A consideration of these circumstances renders it not altogether improbable that these continents were originally conjoined, and that, at some former physical revolution or catastrophe, they may have been rent asunder by some tremendous power, when the waters of the ocean rushed in between them, and left them separated as we now behold them. That power which is said to "remove mountains," which "shaketh the earth out of her place," and causeth "the pillars thereof to tremble," is adequate to produce such an effect; and effects equally stupendous appear to have been produced when the waters of the great deep covered the tops of the highest mountains, when the solid strata of the earth were bent and disrupted, and rocks of enormous size transported from one region of the earth to another. There appears no great improbability in the supposition that such an event may have taken place at the universal deluge, when the original constitution of the globe seems to

\* From a comparison of the length of different degrees of the meridian, lately measured, it is probable that the difference of the diameters is somewhat less than is here stated. Its equatorial diameter is about 7534 miles, and its polar about 7508.

have undergone a dreadful change and disarrangement.

Between the two continents now mentioned are two immense bands of water, extending nearly from the northern to the southern extremities of the globe, one of which is 10,000, and the other 3,000 miles broad. These vast collections of water surround the continents and islands, and form numerous seas, straits, gulfs, and bays, which indent and diversify the coasts through every region of the earth. They occupy a square surface of 148,000,000 of miles, forming about three-fourths of the surface of the globe, and containing about 296,000,000 of *cubical* miles of water, sufficient to cover the whole globe to the depth of 2600 yards. This vast superabundance of water, compared with the quantity of land, it is probable, is peculiar to our globe, and that no such arrangement exists on the surface of the other planets of our system. It is probable that such an extensive ocean did not exist at the period of the original formation of the earth, and that such a disproportionate accumulation of water took place in consequence of the deluge. The present constitution of the earth, and the disproportion of the water to the dry land, are circumstances more adapted to a race of fallen intelligences than to beings in a state of innocence, and adorned with the image of their Creator.

Beside the circumstances now stated, the earth is diversified with extensive ranges of mountains, which stretch in different directions along the continents and islands, rearing their summits, in some instances, several miles above the level of the ocean, and diversifying in various modes the landscape of the earth. From these mountains flow hundreds of majestic rivers, some of them more than 2000 miles in length, fertilizing the countries through which they flow, and forming a medium of communication between the inland countries and the ocean. The atmosphere is thrown around the whole of this terraqueous mass, by means of which, and the operation of the solar heat, a portion of the ocean is carried up to the region of the clouds in the form of vapor, which diffuses itself over every region of the earth, and is again condensed into rains and dews, to supply the sources of rivers, and to distribute fertility throughout every land. This atmosphere is the region of the *winds*, whether fanning the earth with gentle breezes, or heaving the ocean into mountainous billows, and overturning forests by hurricanes and tornadoes. It is the theater where thunders roll and lightnings flash, where the fiery meteor sweeps along with its luminous train, and where the *aurora borealis* display their fantastic coruscations. It is constituted by a law of the Creator to sustain the principle of life, and to preserve in existence and in comfort not only man, but all the tribes of animated existence which traverse the regions of earth, air, or sea, without the benign influence of which this globe would be soon left without a living inhabitant.

Were the earth to be viewed from a point in the heavens, suppose from the moon, it would present a pretty variegated, and sometimes a mottled appearance. The distinction between its seas, oceans, continents, and islands would be clearly marked, which would appear like brighter and darker spots upon its disc. The continents would appear bright, and the ocean of a darker hue, because water absorbs the greater part of the solar light that falls upon it. The level plains (excepting, perhaps, such spots as the Arabian deserts of sands) would appear of a somewhat

darker color than the more elevated and mountainous regions, as we find to be the case on the surface of the moon. The islands would appear like small bright specks on the darker surface of the ocean; and the lakes and Mediterranean seas like darker spots, or broad streaks intersecting the brighter parts of the land. By its revolution round its axis, successive portions of its surface would be brought into view, and present a different aspect from the parts which preceded. Were the first view taken when the middle of the Pacific Ocean appeared in the center, almost the whole hemisphere of the earth would present a dull and somber aspect, except a few small spots near the middle, where the Marquesas, the Sandwich, and the Society Isles are situated, and some bright streaks on its north-eastern, north-western, and south-western borders, where the north-western parts of America, the north-eastern parts of Asia and New Holland are situated. In about six hours afterward the whole of Asia, with its large islands, Borneo, Sumatra, New Guinea, &c., would come into view and diversify the scene, having a portion of the Pacific on the east, and the Indian Ocean and a portion of Africa on the west. In another six hours the whole of Africa and Europe, the Atlantic Ocean, and the eastern part of South America, would make their appearance; and in six hours more the whole of North and South America would appear near the center of the view, having the Atlantic Ocean on the east and the Pacific on the west. All these views would present a considerable variety of aspect, but in every one of them the darker shades would appear to cover the greater part of the view, except, perhaps, in that view which takes in the whole of Asia and part of Africa and Europe.—Each of these views occasionally present a mottled and unstable appearance, on account of the numerous strata of clouds suspended over different regions, which would be seen frequently to shift their positions. These clouds, when dense, and accumulated over particular countries, would prevent certain portions of the land and water from being distinctly perceived. They would sometimes appear like bright spots upon the ocean, by the reflection of the solar rays from their upper surfaces, and sometimes like dark spots over the land. The following figures represent two of the views to which we have alluded:

Fig. 25.

Fig. 26.

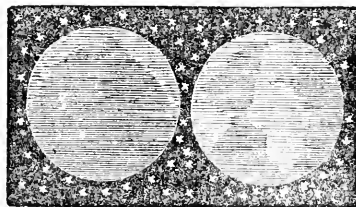

Fig. 25, represents the appearance of the earth when the middle of the Pacific is in the center of the view. Fig. 26, is the appearance when the Atlantic is presented to the spectator's eye, with South and part of North America on the west, and Europe, Africa, and a portion of Asia on the east.

*Internal Structure of the Earth.*—We are now pretty well acquainted with the general outline of the surface of the earth, and the different ramifications of land and water with which it is diversified, except those regions which lie adjacent to the poles. But our knowledge of its *internal*

structure is extremely limited. The deepest mines that have ever been excavated do not descend above a mile from the surface, and this depth is no more, compared with the thickness of the earth, than the slight scratch of a pin upon a large artificial globe compared with the extent of its semi-diameter. What species of materials are to be found two or three thousand miles within its surface, or even within fifty miles, will, perhaps, be forever beyond the power of mortals to determine. Various researches, however, have been lately made as to the materials which compose its upper strata, immediately beneath the surface, and the order in which they are arranged. From these researches we learn that substances of various kinds compose the exterior crust of the globe, and that they are thrown together in almost every possible position; some horizontal, some vertical, and some inclined to each other at various angles. Geologists have arranged the strata of the crust of the earth into various classes: 1. *Primary* rocks, which are supposed to have been formed before all the others, and which compose, as it were, the great frame or groundwork of our globe. These rocks are composed of *granite, gneiss, mica-slate*, and other substances; they form the most lofty mountains, and, at the same time, extend themselves downward beneath all the other formations, as if all the materials on the surface of the globe rested upon them as a basis. 2. *Transition* rocks, which are above the primitive, and rest upon them, and are composed of the larger fragments of the primary rocks, consolidated into continuous masses. These rocks contain the remains of certain organized beings, such as sea-shells, while no such remains are found among the rocks termed primitive. 3. *Secondary* rocks, which lie upon the primary and transition rocks, and which appear like deposits from the other species of rocks. The substances which this class of rocks contain are secondary limestone, coal, oolite, sandstone, and chalk. There are likewise *tertiary, basaltic, and volcanic* rocks, and *alluvial and alluvial* deposits. But it would be foreign to our present subject to ascend into particulars.

From facts which have been ascertained respecting these and various other circumstances connected with the constitution of the earth, it has been concluded that important changes and astonishing revolutions have taken place in its physical structure since the period of its formation; that rocks of a huge size have been rolled from one region of the globe to another, and been carried up to the tops of hills and elevated portions of the land; that the hardest masses of its rocks have been fractured, and its strata bent and dislocated; that in certain places sea-shells, sharks' teeth, the bones of elephants, the hippopotamus, oxen, deer, and other animals, are found mingled together, as if they had been swept along by some overpowering force, amid a general convulsion of nature; that the bed of the ocean has been raised up by the operation of some tremendous power, so as to form a portion of the habitable surface of the globe; and that the loftiest mountains were once covered by the waters of the ocean. From these and other considerations we have reason to believe that the earth now presents a very different aspect from what it did when it first proceeded from the creating hand of its Maker, and when all things were pronounced by him to be "very good." The earth, therefore, as presently constituted, ought not to be considered as a standard or model to be compared with the other planets of our system, and by which to judge

whether they appear to be fitted for being the abodes of intelligent beings. For, in its present state, notwithstanding the numerous objects of sublimity and beauty strewed over its surface, it can be considered as little more than a majestic ruin; a ruin, however, sufficiently accommodated to the character of the majority of inhabitants who have hitherto occupied its surface, whose conduct, in all ages, has been marked with injustice, devastation, and bloodshed.

*Density of the Earth.*—In the year 1773, Dr. Maskelline, the astronomer royal, with other gentlemen, made a number of observations on the mountain Schellien, in Scotland, to determine the attraction of mountains. After four months spent in the necessary arrangements and observations, it was ascertained beyond dispute that the mountain exerted a sensible attraction, leaving no hesitation as to the conclusion that every mountain and every particle of earth is endowed with the same property in proportion to its quantity of matter. The observations were made on both sides of the mountain, and from these it appears that the sum of the two contrary attractions exerted upon the plumbline of the instruments was equal to eleven seconds and a half. Professor Playfair, more than thirty years afterward, from personal observation, endeavored to determine the specific gravity or density of the materials of which Schellien is composed, and after numerous experiments and calculations, it was concluded that "the mean density of the earth is nearly double the density of the rocks which compose that mountain," which seem to be considerably more dense than the mass of those which form the exterior crust of the earth. The density of these rocks was reckoned to be two and a half times the weight of water; consequently the density of the earth is to that of water as five to one; that is, the whole earth, bulk for bulk, is five times the weight of water, so that the earth, as now constituted, would counterpoise five globes of the same size composed of the same specific gravity as water. As the mean density, therefore, of the whole earth's surface, including the ocean, cannot be above twice the density of water, it follows that the interior of the earth must have a much greater density than even five times the weight of water, to counterbalance the want of weight on its surface. Hence we are necessarily led to conclude that the interior parts of the earth, near the center, must consist of very dense substances, denser than even iron, lead, or silver, and that no great internal cavity can exist within it, as some theorists have supposed, unless we could suppose that most of the materials far below the foundation of the ocean are much denser than the heaviest metallic substances yet discovered. La Place has attempted to estimate the earth's density near the center on the following data: If 5.2.5 be its mean density, and 3.1.8, 3.1.5, 2.4.5, and 2.3.5 be assumed as its superficial densities, then, on the theory of compressibility, the density at the center will be 134, 113, 153, and 204.19 respectively. The least of the specific gravities (134) is nearly double the density of zinc, iron, and the ore of lead; and the greatest (204.19) is nearly equal to purified and forged platinum, which is the most ponderous substance hitherto discovered. Yet this ponderous globe, with all the materials on its surface, is carried through the regions of space with a velocity of sixteen hundred thousand miles every day.

*Variety of Seasons.*—The annual revolution of the earth is accomplished in 365 days, 5 hours, 48

minutes, and 51 seconds. In the course of this revolution, the inhabitants of every clime experience, though at different times, a variety of seasons. Spring, summer, autumn, and winter follow each other in constant succession, diversifying the scenery of nature, and distinguishing the different periods of the year. In those countries which lie in the southern hemisphere of the globe, November, December, and January, are the summer months, while in the northern hemisphere, where we reside, these are our months of winter, when the weather is coldest and the days are shortest. In the northern and southern hemispheres, the seasons are opposite to each other, so that when it is spring in the one it is autumn in the other; when it is winter in southern latitudes it is summer with us. During six months, from March 21 to September 23, the sun shines without intermission on the north pole, so that there is no night there during all that interval, while the south pole is all this time enveloped in darkness. From September to March the south pole enjoys the solar light, while the north, in its turn, is deprived of the sun and left in darkness. The sun is at different distances from the earth at different periods of the year, owing to the earth's moving in an elliptical orbit; but it is not upon this circumstance that the seasons depend. For on the first of January we are more than three millions of miles nearer the sun than on the first of July, when the heat of our summer is generally greatest. The true cause of the variation of the seasons consists in the inclination of the axis of the earth to the plane of its orbit; or, in other words, to the *ecliptic*. If its axis were perpendicular to the ecliptic, the equator and the orbit would coincide; and as the sun is always in the plane of the ecliptic, it would in this case be always over the equator; the two poles would be always enlightened, and there would be no diversity of days and nights, and but one season throughout the year. What is meant by the inclination of the axis will appear from the following figures.

Fig. 27.

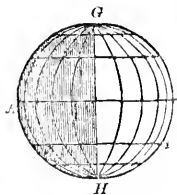
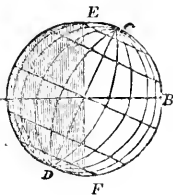

Fig. 28.



Let  $AB$  represent the plane of the ecliptic, or the earth's orbit, and  $CD$  (Fig 28) the axis of the earth, inclined at an angle of  $66\frac{1}{2}^{\circ}$  to the ecliptic, and  $23\frac{1}{2}^{\circ}$  from the perpendicular  $EP$ , or the axis of the ecliptic, and it will represent the position of the axis of the earth with respect to the plane of its orbit. Fig. 27 represents the axis of the earth,  $GI$ , perpendicular to the ecliptic. As the sun can enlighten only the one-half of the globe at a time, it is evident that, if his rays come in the direction from  $B$ , Fig. 28, they cannot illuminate both poles at once. While the north polar circle between  $E$  and  $C$  is enlightened, the regions around the south pole between  $D$  and  $F$  must necessarily remain in the dark. But if the axis of the earth were perpendicular to its orbit, as exhibited in Fig. 27, then both poles would constantly be enlightened at the same time. The following figure will more particularly show the effect of the inclination of the axis of the earth

during its progress through the twelve signs of the zodiac. (See Fig. 29.)

In this representation the ellipse exhibits the earth's orbit seen at a distance, the eye being supposed to be elevated a little above the plane of it. The earth is represented in each of the twelve signs, with the names of the months annexed. In each of the figures  $e$  is the pole of the ecliptic, and  $ed$  its axis, perpendicular to the plane of the orbit.  $P$  is the north pole of the earth;  $Pm$  its axis, about which the earth daily turns from west to east,  $P Ce$  shows the angle of its inclination. During the whole of its course, the axis keeps always in a parallel position, or points always to the same parts of the heavens. If it were otherwise, if the axis of the earth shifted its position in any considerable degree, the most appalling and disastrous effects might be produced; the ocean in many places might overflow the land, and rush from the equator toward the polar regions, and produce a general devastation and destruction to myriads of its inhabitants. If the axis pointed always to the center of its orbit, so as to be continually varying its direction, all the objects around us would appear to whirl about us in confusion; there would be no fixed polar points to guide the mariner, nor could his course be directed through the ocean by any of the stars of heaven.

When the earth is in the first point of Libra, the sun appears in the opposite point of the ecliptic, at Aries, about the 21st of March; and when the earth is in Aries, the sun,  $S$ , will appear in Libra about the 23d of September. At these times both poles of the earth are enlightened, and the day and night are equal in all places. When the earth has moved from Libra to Capricorn, its axis keeping always the same direction, all places within the north polar circle,  $P e$ , are illuminated throughout the whole diurnal revolution, at which time the inhabitants of those places have the sun more than twenty-four hours above the horizon. This happens at the time of our summer solstice, or about the 21st of June, at which time the south polar circle,  $d m$ , is in darkness. While the earth is moving from Libra, through Capricorn, to Aries, the north pole,  $P$ , being in the illuminated hemisphere, will have six months continual day; but while the earth passes from Aries, through Cancer, to Libra, the north pole will be in darkness, and have continual night; the south pole at the same time enjoying continual day. When the earth is at Cancer, the sun appears at Capricorn, at which season the nights in the northern hemisphere will as much exceed the days as the days exceed the nights when the earth was in the opposite point of its orbit.

Our summer is nearly eight days longer than our winter. By summer is meant the time that passes between March 21 and September 23, or between the vernal and autumnal equinoxes; and by winter, the time between September 23 and March 21, the autumnal and vernal equinoxes. The portion of the earth's orbit which lies north of the equinoctial contains 184 degrees, while that portion which is south of the equinoctial contains only 176 degrees, being eight degrees less than the other portion, which is the reason why the sun is nearly eight days longer on the north of the equator than on the south. In our summer the sun's apparent motion is through the six northern signs, Aries, Taurus, Gemini, Cancer, Leo, and Virgo; and in our winter, through the six southern. In the former case, from March 21 to September 23, the sun is about 166 days 11 hours in passing through the northern signs, and

only 178 days 18 hours in passing through the southern signs, from September 23 to March 21, the difference being about 7 days 17 hours. The

Fig. 29.

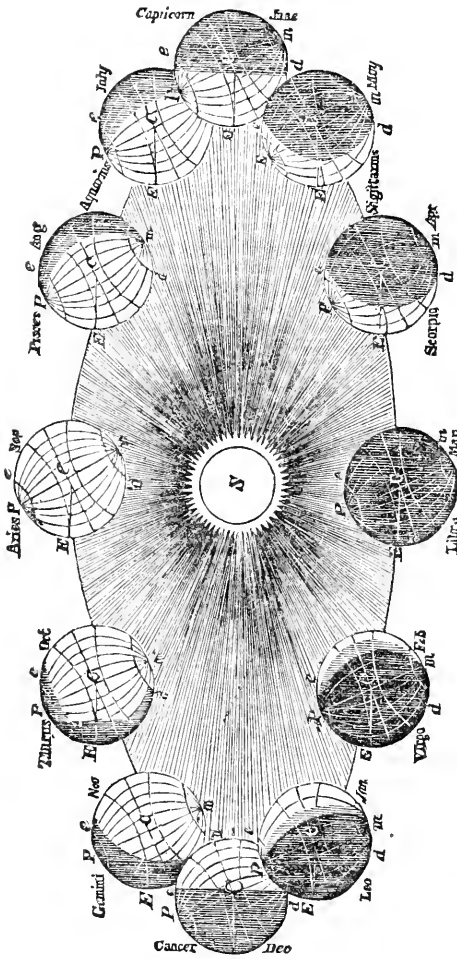

the horizon in summer than in winter, and, consequently, its rays falling more directly and less oblique, the thicker or denser will they be, and so much the hotter. when no counteracting causes from local circumstances exist. Thus, supposing a parcel of rays,  $A B C D E$  (Fig. 30), to fall perpendicularly on any plane ( $D C$ ), and obliquely on another plane ( $E C$ ), it is evident they will occupy a smaller space ( $D C$ ) in the former than ( $E C$ ) in the latter; and, consequently, their heat would be much greater in the lesser space  $D C$  than in the greater space  $E C$ . If, instead of lines, we suppose  $D C$  and  $E C$  to be the diameters of surfaces, then the heat on those surfaces will be inversely as the squares of the diameters. Let  $D C$  be 20 and  $E C$  28; the square of 20 is 400, and the square of 28 is 784, which is nearly double the square of  $D C$ , and, consequently, there is nearly double the quantity of heat on  $D C$  compared with that on  $E C$ , in so far as it depends on the direct influence of the solar rays; but other causes may concur either to diminish or increase the heat in certain places, to which I have already alluded when describing the phenomena of Mercury. 2. The greater length of the day contributes to augment the heat in summer; for the earth and the air are heated by the sun in the day-time, more than they are cooled in the night, and on this account the heat will go on increasing in the summer, and for the same reason will decrease in winter, when the nights are longer than the days. Another reason is, that in summer, when the sun rises to a great altitude, his rays pass through a much smaller portion of the atmosphere, and are less refracted and weakened by it than when they fall more obliquely on the earth, and pass through the dense vapors near the horizon.

The cause of the variety of the seasons can be exhibited with more clearness and precision by means of machinery than by verbal descriptions; and, therefore, those whose conceptions are not clear and well-defined on this subject, should have recourse to orreries and planetariums, which exhibit the celestial motions by wheel-work. There is a small instrument, called a *Tellurion*, which has been long manufactured by Messrs. Jones, Holborn, London, which conveys a pretty clear idea of the motions and phases of the moon, the inclination of the earth's axis to the plane of its orbit, and the changes of the seasons. It may be procured at different prices, from 1*l.* 8*s.* to 4*l.* 14*s.* 6*d.*, according to the size and the quantity of the wheel-work.

The subject of the seasons and the variety of phenomena they exhibit have frequently been the themes both of the philosopher and the poet, who have expatiated on the beauty of the contrivance and the benignant effects they produce; and, therefore, they conclude that other planets enjoy the same vicissitudes and seasons similar or analogous to ours. But although, in the present constitution of our globe, there are many benign agencies which accompany the revolutions of the seasons, and are essential to our happiness in the circumstances in which we now exist, yet it is by no means probable that the seasons, as they now operate, formed a part of the original arrangements of our terrestrial system. Man was at first created in a state of innocence, and adorned with the image of his Maker; and the frame of nature, we may confidently suppose, was so

reason of this difference is, that the earth moves in an elliptical orbit, one portion of which is nearer the sun than another, in consequence of which the sun's apparent motion is slower while it appears in the northern signs than while it traverses the southern ones.

As the sun is farther from us in summer than in winter, it may naturally be asked why we experience the greatest heats in the former season. The following, among other reasons, may be as-

Fig. 30.

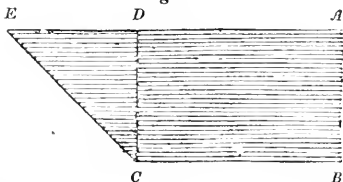

signed, which will partly account for this effect: 1. The sun rises to a much higher altitude above



arranged as to contribute in every respect both to his sensitive and intellectual enjoyment. But neither the horrors of winter, and its dreary aspect in northern climes, nor the scorching heats and appalling thunder-storms which are experienced in tropical climates, are congenial to the rank and circumstances of beings untainted with sin and endowed with moral perfection. Such physical evils and inconveniences as the change of seasons occasionally produces, appear to be only adapted to man in his present state of moral degradation. In the primeval state of the world, it is not unlikely that the axis of the earth had a different direction from what it has at present, and that, instead of scorching heats and piercing colds, and the gloom and desolations of winter, there was a more mild and equable temperature, and something approaching to what the poet calls "a perpetual spring." We are assured, from the records of sacred history, that the original constitution of the earth has undergone a considerable change and derangement: its strata were disrupted, "the fountains of the great deep were broken up," and a flood of waters covered the tops of the loftiest mountains; the effects of which are still visible in almost every region of the globe. At that memorable era, it is highly probable those changes were introduced which diversify the seasons and produce those alarming phenomena and destructive effects which we now behold; but as man advances in his moral, intellectual, and religious career, and in proportion as his mental and moral energies are made to bear on the renovation of the world, he has it in his power to counteract or meliorate many of the physical evils which now exist. Were the habitable parts of the earth universally cultivated, its marshes drained, and its desolate wastes reduced to order and vegetable beauty by the hand of art, and replenished with an industrious and enlightened population, there can be little doubt that the seasons would be considerably meliorated, and many physical evils prevented with which we are now annoyed. And all this is within the power of man to accomplish, provided he chooses to direct his wealth, and his intellectual and moral energies, into this channel. If these remarks have any foundation in truth, then we ought not to imagine that the earth is a standard by which we are to judge of the state of other planetary worlds, or that they are generally to be viewed as having a diversity of seasons similar to ours.

The following facts, in addition to the preceding, may be noted in relation to the earth: Under the equator, a pendulum, of a certain form and length, makes 86,400 vibrations in a mean solar day; but, when transported to London, the same pendulum makes 86,535 vibrations in the same time. Hence it is concluded that the intensity of the force urging the pendulum downward at the equator is to that at London as 86,490 to 86,535, or as 1 to 1.00315; or, in other words, that a mass of matter at the equator, weighing 10,000 pounds, exerts the same pressure on the ground as 10,031½ of the same pounds transported to London would exert there. If the gravity of a body at the equator be 1, at the poles it will be 1.00569, or about the 1-194th part heavier; that is, a body weighing 194 pounds at the equator would weigh 195 pounds at the north pole; so that the weight of bodies is increased as we advance from the equator to the poles, owing to the polar parts being nearer the center of the earth than the equatorial, and the centrifugal force being diminished. It is this variation of the action of gravity in different latitudes that causes

the same pendulum to vibrate slower at the equator than in other places, as stated above. For a pendulum to oscillate seconds at the equator, it must be thirty-nine inches in length; and at the poles, thirty-nine and one-fifth inches.

The *tropical* year, or the time which the sun (or the earth) takes in moving through the twelve signs of the ecliptic, from one equinox to the same equinox again, is three hundred and sixty-five days, five hours, forty-eight minutes, and fifty-one seconds. This is the proper or natural year; because it always keeps the same seasons to the same months. The *sidereal* year is the space of time the sun takes in passing from any fixed star until it returns to the same star again. It consists of three hundred and sixty-five days, six hours, nine minutes, and eleven and a half seconds, being twenty minutes and twenty and a half seconds longer than the true solar year. This difference is owing to the regression of the equinoctial points, which is fifty seconds of a degree every year; and, to pass over this space, the sun requires twenty minutes and twenty and a half seconds. The earth moves in an elliptical orbit, whose *eccentricity*, or distance of its foci from the center, is 1,618,000 miles: that is, the ellipse or oval in which it moves is double the eccentricity, or 3,236,000 miles longer in one direction than it is in another, which is the reason that the sun is farther from us at one season of the year than at another. This is ascertained from the variation of the apparent diameter of the sun. About the first of January, when he is nearest the earth, the apparent diameter is thirty-two minutes, thirty-five seconds; and on the 1st of July, when he is most distant, it is only thirty-two minutes, thirty-one seconds. This proves that the earth has a slower motion in one part of its orbit than in another. In January, it moves at the rate of about 69,690 miles an hour, but in July its rate of motion every hour is only about 66,400 miles; a difference of more than 3000 miles an hour.

#### IV. OF THE PLANET MARS.

The earth is placed, in the solar system, in a position between the orbits of Venus and Mars. The two planets, Mercury and Venus, which are placed *within* the orbit of the earth, and whose orbits lie between it and the sun, are termed the *inferior* planets. Those whose orbits lie *beyond* the orbit of the earth, at a greater distance from the sun, as Mars, Jupiter, Saturn, and Uranus, are termed *superior* planets. The motions and aspects of all the superior planets, as seen from the earth, differ considerably from those which are exhibited by the inferior. In the first place, the inferior planets are never seen but in the neighborhood of the sun, none of them ever appearing beyond forty-eight degrees from that luminary; whereas, the superior planets appear at all distances from the sun, even in the opposite quarter of the heavens, or 180 degrees from the point in which the sun may happen to be placed. This could not possibly happen unless their orbits were *exterior* to that of the earth, and the earth placed at such times between them and the sun. In the next place, the inferior planets, when viewed through telescopes, exhibit, at different times, all the phases of the moon; but the superior planets never appear either horned or in the shape of a half moon. The planets Jupiter, Saturn, and Uranus, never appear in any other shape than *round*, or with full enlightened hemispheres. This circumstance of itself furnishes a proof that we

see these planets always in a direction not very remote from that in which they are illuminated by the solar rays; and, consequently, that we occupy a station which is never very far removed from the center of their orbits. It proves, in other words, that the path of the earth round the sun is entirely included within their orbits, and likewise that this circular path of the earth is of small diameter compared with their more expansive orbits. This may be illustrated by the following figures. Let *S*, Fig. 32, represent the sun; *A B*

Fig. 31.

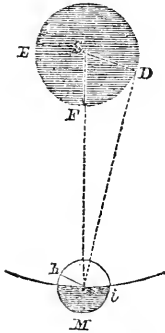
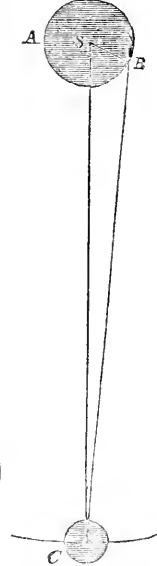

Fig. 33.



Fig. 32.



the orbit of the earth; and *C* the planet Saturn, about ten times farther from the sun than the earth is. Suppose *B* to represent the earth at its greatest elongation from the sun, as seen from Saturn; the angle, *S C D*, being so small, it is evident that an observer on the earth, at *B*, can see little or nothing of the dark hemisphere of Saturn at *C*, but must perceive the whole enlightened hemisphere of the planet, within a small fraction, which fraction is not perceptible by our best telescopes.

There is only one of the superior planets that exhibit any perceptible *phases*, and that is the planet *Mars*. In Fig. 31, *S* represents the sun; *E D*, the orbit of the earth; *M*, Mars; and *D*, the earth at its greatest elongation, as seen from Mars. In this case the angle *S M D* is much larger than in the former case, as Mars is much nearer to the earth than Saturn or any other of the superior planets. Consequently, a spectator on the earth is enabled to see a greater portion of the dark hemisphere of Mars, and, of course, loses sight of a corresponding portion of his enlightened disc.— This is represented by the line *h i*. This gibbous phase of Mars, however, differs only in a small degree from a circle; it is never less than seven-eighths of the whole disc. This phase is represented in Fig. 33. When the earth arrives near the point *E*, when Mars appears in opposition to the sun, the whole of his enlightened hemisphere is then visible. The extent of the gibbous phase of this planet affords a measure of the angle *S M D*, and, therefore, of the proportion of the distance, *S M* of Mars, to *S D* or *S E*, the distance of the earth from the sun, by which we are war-

ranted to conclude that the diameter of the orbit of Mars cannot be less than 1 1-2 that of the orbit of the earth. The phases of Saturn, Jupiter, and Uranus being quite imperceptible, demonstrate that their orbits must include both the orbit of the earth and that of Mars; and, consequently, that they are removed at a much greater distance than either of these bodies from the center of the system.

Before proceeding to a particular description of the phenomena connected with the planet Mars, I shall give a brief sketch of the motions peculiar to this planet, which will serve, in some measure, as a specimen of the apparent motions of all the other superior planets. In the following figure *S*

Fig. 34.

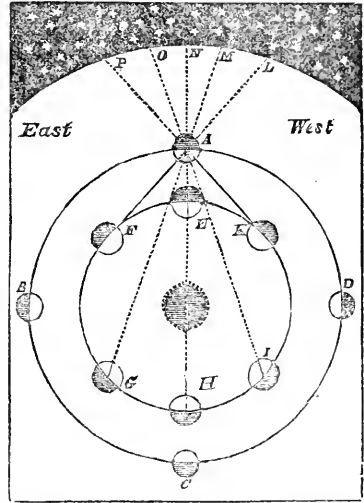

represents the sun; *A B C D* the planet Mars in four different positions in its orbit; *E F G H I K* the orbit of the earth; and *L M N O P*, a segment of the starry heavens. Suppose Mars at *A* and the earth at *E*, directly between it and the sun, then all the planet's enlightened hemisphere will be turned toward the earth, and it will appear like the full moon. When the planet is at *B* it will be gibbous, like the moon a few days before or after the full. At *C* it would again appear wholly enlightened, were it not in the same part of the heavens with the sun. At *D* it is again gibbous, as seen from *E*, and will appear less gibbous as it advances toward *A*. At *A* it is said to be in opposition to the sun, being seen from the earth at *E* among the stars at *N*, while the sun is seen in the opposite direction, *E C*. When the planet is at *C* and the earth at *E*, it is said to be in conjunction with the sun, being in the same part of the heavens with that luminary. In regard to all the superior planets, there is but one conjunction with the sun during the course of their revolution; whereas the inferior planets, Mercury and Venus, have two conjunctions, as formerly explained. Let us now attend to the apparent motions of this planet. Suppose the earth at *F*, and the planet at rest in its orbit at *A*; it will be projected or seen by a ray of light among the stars at *L*; when the earth arrives at *G*, the planet will appear at *M*, by the ray *G M*; and in the same manner, when the earth is at *H*, *I*, and *K*, the planet will be seen among the stars at *N*, *O*, and *P*; and, therefore, while the earth moves over the large part of its orbit, *F H K*, the

planet will have an apparent motion from *L* to *P* among the stars; and this motion is from west to east, in the order of the signs, or in the same direction in which the earth moves; and the planet is then said to be *direct* in motion. When the earth is at *K* and the planet appears at *P*, for a short space of time it appears *stationary*, because the ray of light proceeding from *P* to *K* nearly coincides with the earth's orbit and the direction of its motion. But when the earth moves on from *K* to *E*, the planet will appear to return from *P* to *N*; and while the earth moves from *E* to *F*, the planet will still continue to retrograde from *N* to *L*, where it will again appear stationary as before. From what has been now stated, it is clear, that since the part of the orbit which the earth describes in passing through *F H K* is much greater than the arc *K E F*, and the space *L P* which the planet describes in its direct and retrograde motion is the same; therefore, the *direct motion is very slow* from *L* to *P*, in comparison of the *retrograde motion* from *P* to *L*, which is performed in much less time.

In the above description I have supposed the planet at *rest* in its orbit at *A*, in order to render the explanation more easy and simple, and the diagram less complex than it would have been had we traced the planet through different parts of its orbit, together with the motions of the earth. But the appearances are the same, whether we suppose the planet to be at rest or in motion. The only difference is in the *time* when the retrograde or direct motions happen, and in the *places* of the heavens where the planet will be at such times situated. What has now been stated in regard to the apparent motions of Mars will apply to Jupiter, Saturn, and all the superior planets, making allowance for the difference of time in which their direct and retrograde motions are performed. All the superior planets are retrograde in their apparent motions when in *opposition*, and for some time before and after; but they differ greatly from each other, both in the extent of their *arc* of retrogradation, in the *duration* of their retrograde movement, and in its *rapidity*, when swiftest. It is more extensive and rapid in the case of Mars than of Jupiter, of Jupiter than of Saturn, and of Saturn than of Uranus. The longer the periodic time or annual revolution of a superior planet, the more frequent are its stations and retrogradations; they are less in quantity, but continue a longer time. The mean arc of retrogradation of Mars, or from *P* to *L*, Fig. 34, is sixteen degrees, twelve minutes, and it continues about seventy-three days; while the mean arc of retrogradation of Jupiter is only nine degrees, fifty-four minutes, but its mean duration is about 121 days. The time between one opposition of Saturn and another is 378 days, or one year and thirteen days. The time between two conjunctions or oppositions of Jupiter is 397 days, or one year and thirty-three days. But Mars, after an *opposition*, does not again come into the same situation until after two years and fifty days. It is only at and near the time of the opposition of Mars that we have the best telescopic views of that planet, as it is then nearest the earth; and, consequently, when it has passed its opposition for any considerable time, a period of two years must elapse before we see it again in such a conspicuous situation. Hence it is that this planet is seldom noticed by ordinary observers, except during a period of three or four months every two years. At all other times it dwindles to the apparent size of a small star.

*Distance, Motion, and Orbit of Mars.*—This

planet is ascertained to be about 145 millions of miles from the sun. From what we have stated above, it is obvious that, in the course of its revolution, it is at very different distances from the earth. When at its greatest distance, as when the earth is at *E*, and the planet at *C*, Fig. 34, it is 240 millions of miles from the earth. This will appear from an inspection of the figure. The distance, *E S*, from the earth to the sun is 95 millions of miles; the distance, *S C*, of Mars from the sun is 145 millions. These distances, added together, amount to the whole distance from *E* to *C*, or from the earth to Mars when in conjunction with the sun. When nearest the earth, as at *A*, it is only 50 millions of miles distant from us. For as the whole distance of the planet from the sun, *A S*, is 145 millions, subtract the distance of the earth from the sun, *E S*=95 millions, and the remainder will be the distance of the planet, *E A*=50 millions of miles from the earth. Small as this distance may appear compared with that of some of the other planets, it would require more than 275 years for a steam-carriage, moving without intermission at the rate of twenty miles an hour, to pass over the space which intervenes between the earth and Mars at its nearest distance.

From what has been now stated, it is evident that this planet will present a very different aspect, as to size and splendor, in the different parts of its orbit. When nearest to the earth, it appears with a surface twenty-five times larger than it does at its greatest distance, and seems to vie with Jupiter in apparent magnitude and splendor. But, when verging toward its conjunction with the sun, it is almost imperceptible. And this is one proof, among others, of the truth of the Copernican system. All its motions, stations, and direct and retrograde movements, and the times in which they happen, exactly accord with its position in the system and the motion of the earth, as a planet between the orbits of Venus and Mars. Whereas, were the earth supposed to be the center of this planet's motion, according to the Ptolemaic hypothesis, it would be impossible to account for any of the phenomena above stated.

The orbit of Mars is 901,964,000, or more than 900 millions of miles in circumference. Through this space it moves in one year and 322 days, or in 16,488 hours. Consequently, its rate of motion is 54,640 miles every hour, which is more than a hundred times the greatest velocity of a cannon ball when it leaves the mouth of the cannon. The diurnal rotation of this planet, or its revolution round its axis, is accomplished in twenty-four hours, thirty-nine minutes, twenty-one seconds, which is about two-thirds of an hour longer than our day. This period of rotation was first ascertained by Cassini, from the motion of certain spots on its surface, which I shall afterward describe. Its axis is inclined to the plane of its orbit in an angle of thirty degrees, eighteen minutes, which is nearly seven degrees more inclined from the perpendicular than that of the earth. This motion is in the same direction as the rotation of the earth, namely, from west to east. The inclination of the orbit of Mars to that of the earth is one degree, fifty-one minutes, six seconds, so that this planet is never so much as two degrees either north or south of the ecliptic. The orbit of Mars is considerably *eccentric*. Its eccentricity is no less than 13,463,000 miles, or about 1-21 of its diameter, which is more than eight times the eccentricity of the orbit of the earth. Hence it follows, that Mars, when in opposition to the sun, may be nearer the earth by

a considerable number of millions of miles at one time than at another, when he happens to be about his *perihelion*, or nearest distance from the sun at such opposition. On the 27th of August, 1719, this planet was in such a position, being in opposition within two and a half degrees of its perihelion, and nearer to the earth than it had been for a long period before; so that its magnitude and brightness were so much increased, that, by common spectators, it was taken for a new star.

*Appearance of the Surface of Mars when viewed through Telescopes.*—It was not before the telescope was brought to a certain degree of perfection that spots were discovered on the surface of Mars. This instrument was first directed to the heavens by Galileo, in the year 1610; but it was not until the beginning of 1666 that any of the spots which diversify this planet were discovered. On the 6th of February, that year, in the morning, Cassini, with a telescope of sixteen feet long, saw two dark spots on the face of Mars, as represented in Fig. 35; and on February 21, in the evening, he saw on the other face of the planet two other spots, somewhat like those of the first, but larger, as represented in Fig. 36.

Fig. 35.

Fig. 36.

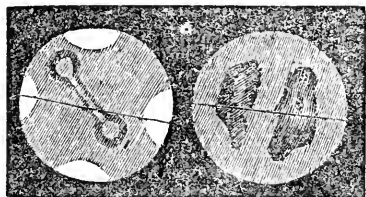

These figures are copied from the first volume of the Transactions of the Royal Society. Afterward, continuing his observations, he found the spots of these two faces to turn by little and little from east to west, and to return at last to the same situation in which he had first seen them. Campani and several other astronomers observed similar spots about the same time at Rome, and Dr. Hook in England. Some of these observers were led to conclude, from the motion of these spots, that the rotation of this planet was accomplished in thirteen hours; but Cassini, who observed them with particular care, proved that the period of rotation was about twenty-four hours and forty minutes, and showed that the error of the other astronomers arose from their not distinguishing the difference of the spots which appeared on the opposite sides of the disc of Mars. The deductions of Cassini on this point have been fully confirmed by subsequent observations.

Maraldi, a celebrated French mathematician and astronomer, made particular observations on these spots in the year 1704. He observed that the spots were not always well-defined, and that they often changed their form, not only in the space of time from one opposition to another, but even within the space of a month; but some of them continued of the same form long enough to ascertain their periods. Among these was an oblong spot, not unlike one of the broken belts of Jupiter, that did not reach quite round the body of Mars, but had, not far from the middle of it, a small protuberance toward the north, so well-defined as to enable him to settle the period of its revolution at twenty-four hours, thirty-nine minutes; only one minute less than as Cassini had determined it. This appearance of Mars is represented in Fig. 37. On the 27th of August, 1719, the same observer, with a telescope of thir-

ty-four feet in length, perceived, among several other spots, a long belt that reached about half way round the planet, not parallel to its equator, to the end of which another short belt was joined, so as to form an angle a little obtuse, as represented in Fig. 38.

Fig. 37.

Fig. 38.

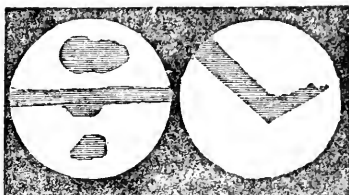

The following figures represent the appearance of the spots as seen by Dr. Hook in 1666. He saw Mars on March 3, 1666, as represented in Fig. 39, which appearance was taken down at the moment of observation. On the 23d of the same month he perceived the spots as delineated in Fig. 40, which appears to have been either the same

Fig. 39.

Fig. 40.

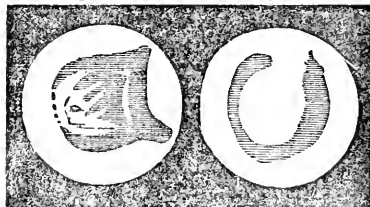

spots in another position, or some other spots on the other hemisphere of the planet.

The following are two views of this planet by Sir William Herschel, who has given a great variety of delineations of the different appearances of Mars in the Transactions of the Royal Society of London for 1784.

Fig. 41.

Fig. 42.

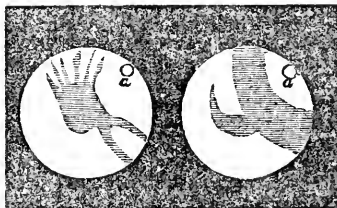

My own views of this planet have not been numerous, as it is only at intervals of two years, when near its opposition, that observations can be made on its surface with effect. I have, however, distinctly perceived its surface as delineated in Figures 43 and 44.

Fig. 43.

Fig. 44.

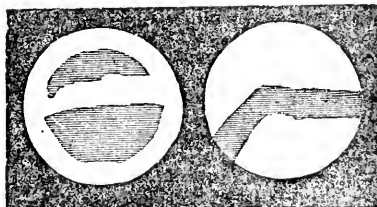

These observations were made in November

and December, 1832, and in January, 1837, and the appearances were very nearly the same; but the spots as represented in the two figures were seen at different times, and were evidently on different hemispheres of the planet, which were presented in succession by its motion of rotation. The instrument used in the observations was a  $4\frac{1}{2}$  inch achromatic telescope, with magnifying powers of 150 and 180 times.

Beside the dark spots here delineated, there is a small portion of the globe of Mars, round its south pole, which has, at least occasionally, a much brighter appearance than the other parts. Maraldi, who made observations on Mars about the year 1719, says, that this bright spot had been noticed for sixty years before that period, and that it is more permanent than any of the other spots of Mars; that this segment or zone is not all of equal brightness, more than one-half of it being brighter than the rest; that the part which is least bright is subject to great changes, and has sometimes disappeared; and that there has sometimes been seen a similar luminous zone round the north pole of Mars, which has appeared of different brightness in different years. The bright spot at the polar point is represented at *a*, Figures 41 and 42. These white spots have been conjectured to be snow, as they disappear when they have been long exposed to the sun, and are greatest when just emerging from the long night of the polar winter in that planet. This is the opinion of Sir W. Herschel, in his paper on this subject, in the Philosophical Transactions. "In the year 1751," says this astronomer, "the south polar spot was extremely large, which we might well expect, as that pole had but lately been involved in a whole twelve-month's darkness and absence of the sun; but in 1783, I found it considerably smaller than before, and it decreased continually from the 20th of May until about the middle of September, when it seemed to be at a stand. During this last period, the south pole had already been about eight months enjoying the benefit of summer, and still continued to receive the sunbeams, though, toward the latter end, in such an oblique direction as to be but little benefited by them. On the other hand, in the year 1751, the north polar spot, which had been its twelve-month in the sunshine, and was but lately returning into darkness, appeared small, though undoubtedly increasing in size." Hence he concludes, "that the bright polar spots are owing to the vivid reflection of light from frozen regions, and that the reduction of those spots is to be ascribed to their being exposed to the sun."

*Atmosphere of Mars.*—From the gradual diminution of the light of the fixed stars when they approach near the disc of Mars, it has been inferred that this planet is surrounded with an atmosphere of great extent. Although the extent of this atmosphere has been much overrated, yet it is generally admitted by astronomers that an atmosphere of considerable density and elevation exists. Both Cassini and Roemer observed a star, at six minutes from the disc of Mars, become so faint before it was covered by the planet, that it could not be seen even with a three feet telescope; which, in all probability, was caused by the light of the star being obscured by passing through the dense part of the atmosphere of the planet. It is, doubtless, owing to this circumstance that Mars presents so ruddy an appearance, more so than any other planet or star in the nocturnal sky. When a beam of light passes through a dense medium, its color inclines to red, the other rays being partly reflected or absorbed. Thus the

morning and evening clouds are generally tinged with red, and the sun, moon, and stars, when near the horizon, either rising or setting, uniformly assume a ruddy aspect, because their light then passes through the lower and denser part of our atmosphere. When the light of the sun passes through the atmosphere of Mars, the most refrangible colors, such as the violet, will be partly absorbed; and before the reflected rays reach the earth, they must again pass through the atmosphere of the planet, and be deprived of another portion of the most refrangible rays; and, consequently, the red rays will predominate, and the planet assume a dull red color. This I conceive to be the chief reason why I could never perceive Mars in the day-time, even when in the most favorable position, so distinctly as Jupiter, although the quantity of solar light which falls on this planet is more than eleven times greater than what falls on Jupiter; which seems to indicate that Jupiter is surrounded with a less dense and more transparent atmosphere. Sir W. Herschel, though he questions the accuracy of some of the observations of the dimness caused by the appulses of the fixed stars to this planet, yet admits that it has a considerable atmosphere. "For," says he, "beside the permanent spots on its surface, I have often noticed occasional changes of partial bright belts, and also once a darkish one in a pretty high latitude; and these alterations we can hardly ascribe to any other cause than the variable disposition of clouds and vapors floating in the atmosphere of the planet."

*Conclusions respecting the Physical Constitution of Mars.*—From the preceding observations and views we have exhibited of this planet, I presume we are warranted to deduce, with a high degree of probability, the following conclusions: 1. That land and water, analogous to those on our globe, exist in the planet Mars. The dark spots are obviously the water or seas upon its surface, which reflect a much less proportion of the solar light than the land. "The seas," says Sir John Herschel, "by a general law in optics, appear greenish, and form a contrast to the land. I have noticed this phenomenon on many occasions, but never more distinct than on the occasion when the drawing was made;" from which the figure of Mars in his "Astronomy" is engraved. It is not improbable, from the size of the dark spots compared with the whole disc of Mars, that about one-third or one-fourth of the surface of that planet is covered with water. If this estimate be nearly correct, it will follow that the quantity of land and water on Mars is nearly in a reverse proportion to that which obtains on our globe, where the quantity of water is nearly four times greater than that of the land. The dark spots in some of the views given above seem to convey the idea of several large gulfs or bays running up into the land. The various appearances of these spots which we have delineated are partly owing to the different relations and positions in which they appear during different periods of the planet's rotation, as I have already shown, would happen in the appearance of the earth were it viewed from a distance in the heavens (see page 41). 2. It is probable, too, that there are strata of clouds of considerable extent occasionally floating in the atmosphere of Mars; for some of the observers referred to above have remarked that some of the spots "changed their form in the course of a month;" and Sir W. Herschel, as above stated, declares that he has noticed "occasional changes of partial bright belts, and also once of a darkish one." These, in all probability, were clouds of

greater or less density, which, for the most part, would appear brighter than the seas by the reflection of the solar rays from their upper surfaces; for although the *under* surface of dense clouds appears dark to us who view them from below, yet, were we to view their upper surface from a distance when the sun shines upon them, they would undoubtedly present a bright appearance by the reflection of the solar rays. It is, doubtless, owing to the occasional interposition of such clouds in the atmosphere of Mars, that the *permanent* spots sometimes appear to vary their form and aspect. 3. A variety of seasons, somewhat similar to ours, must be experienced in this planet. The diversity of seasons on our globe arises chiefly from the inclination of its axis to the plane of the ecliptic. Now, in reference to Mars, the axis of rotation is inclined to its orbit at even a greater angle than that of the earth; and, therefore, the contrast between its opposite seasons is probably more marked and striking than on the earth. The seasons will also continue for a much longer period than with us, as the year in Mars is nearly double the length of ours, so that summer and winter will be prolonged for a period of eight or nine months respectively. If the opinion of Sir W. Herschel be correct, that the white spots at the poles of Mars are caused by the reflection of the sun's rays from masses of ice and snow, it will afford an additional proof of the existence of a diversity of seasons on this planet, and that its inhabitants are subjected to a winter of great severity and of long duration. 4. This planet bears a more striking resemblance to the earth than any other planet in the solar system. Its distance from the sun, compared with that of the other superior planets, is but a little more than that of the earth. The distinction of land and water on its surface is more strikingly marked than on any of the other planets. It is encompassed with an atmosphere of considerable extent. It is probable that large masses of clouds are occasionally formed in that atmosphere, such as sometimes hover over the whole of Britain, and even of Europe, for several weeks at a time. The length of the day is nearly the same as ours, and it has evidently a succession of different seasons. Were we warranted from such circumstances to form an opinion respecting the physical and moral state of the beings that inhabit it, we might be apt to conclude that they are in a condition not altogether very different from that of the inhabitants of our globe.

*Magnitude and Extent of Surface of Mars.*—This planet is now estimated to be about 4200 miles in diameter, which is only a little more than half the diameter of the earth. It contains 38,792,000,000 or more than 38 thousand millions of solid miles; and the number of square miles on its surface is 55,417,824, or more than fifty-five millions, which is about six millions of square miles more than on all the habitable parts of our globe. At the rate of population formerly stated, 200 to a square mile, it would contain a population of more than fifteen thousand five hundred millions, which is nineteen times the number of the inhabitants of the earth; but, as it is probable that one-third of the surface of Mars is covered with water, should we subtract one-third from these sums, there would still remain accommodation for twelve times the number of the population of our globe.

No moon or secondary planet has yet been discovered about Mars; yet this is no proof that it is destitute of such an attendant; for as all the secondary planets are much less than their prima-

ries, and as Mars ranks among the smallest planets of the system, its satellite, if any exist, must be extremely small. The second satellite of Jupiter is only the 1-43d part of the diameter of that planet; and a satellite bearing the same proportion to Mars would be only ninety-seven miles in diameter. But, suppose it were double this size, it could scarcely be distinguishable by our telescopes, especially when we consider that such a satellite would never appear to recede to any considerable distance from the margin of Mars. The distance of the first satellite of Jupiter is only three diameters of that planet from its center; and the distance of the first satellite of Saturn is but one diameter and two-thirds from its center. Now, if a satellite of the size we have supposed were to revolve round Mars at the distance of only two or three of its diameters, its nearness to the body of Mars would generally prevent its being perceived, unless with telescopes of very great power and under certain favorable circumstances; and it could never be expected to be seen but about the time of that planet's opposition to the sun, which happens only at an interval of more than two years. If such a satellite exist, it is highly probable that it will revolve at the nearest possible distance from the planet, in order to afford it the greatest quantity of light; in which case it would never be seen beyond two minutes of a degree from the margin of the planet, and that only in certain favorable positions. If the plane of its orbit lay nearly in a line with our axis of vision, it would frequently be hidden either by the interposition of the body of Mars or by transiting its disc. It is therefore possible, and not at all improbable, that Mars may have a satellite, although it has not yet been discovered. It is no argument for the non-existence of such a body that we have not yet seen it; but it ought to serve as an argument to stimulate us to apply our most powerful instruments to the regions around this planet with more frequency and attention than we have hitherto done, and it is possible our diligence may be rewarded with the discovery. The long duration of winter in the polar regions of Mars seems to require a moon to cheer them during the long absence of the sun; and if there be none, the inhabitants of those regions must be in a far more dreary condition than the Laplanders and Greenlanders of our globe.

*Proportion of Light on the Surface of Mars.*—As the quantity of solar light on any of the planets is in an inverse proportion to their distances from the sun, the quantity of light which falls upon Mars will be much less than that which we enjoy. It is nearly in the proportion of 43 to 100, which is less than one-half of the light which falls upon the earth. This is partly the reason why Mars appears so much less brilliant than Venus, but it is not the only reason; for Jupiter appears much more brilliant than Mars, although he is placed at a much greater distance from the sun. The refraction, reflection, and absorption of the rays of light, in passing through the dense atmosphere to which we have alluded, form, doubtless, one principal reason why Mars appears more somber in its aspect than Jupiter or Venus. The following figure represents the apparent size of the sun as seen from Mars and the earth. The circle *m* represents the size of the sun as seen from Mars, and *e* as seen from the earth. The degree of *heat* on different parts of this planet will depend upon various circumstances; the inclination of its axis, the positions of places in respect to its equator and poles, the nature of its soil, the materials which compose its surface, the quantity of

Fig. 15.

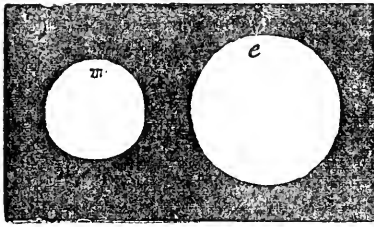

water in different regions, the constitution of its atmosphere, and other circumstances with which we are unacquainted.

The figure of Mars is an *oblate spheroid*, like that of the earth, but much flatter at the poles.—Its equatorial diameter is to its polar as 1355 to 1272, or nearly as 16 to 15; consequently, if its equatorial diameter be 4200 miles, its polar diameter will be only 3937, which is 263 miles shorter than the equatorial. The *mass* of this planet compared with that of the sun is as 1 to 1,846,082. Its *density*, compared with water, is as 3.27 to 1, which is considerably less than that of the earth, but greater than the general density of the rocks and other materials which compose the surface of our globe. A body which weighs one pound on the surface of the earth would weigh only five ounces six drachms on the surface of Mars.

#### V. ON THE LATELY-DISCOVERED PLANETS, VESTA, JUNO, CERES, AND PALLAS.

The immense interval which lies between the orbits of Mars and Jupiter led some astronomers to surmise that a planet of considerable magnitude might possibly exist somewhere within this limit. This conjecture was grounded on the intervals which exist between the rest of the planetary orbits. Between the orbits of Mercury and Venus there is an interval of 31,000,000 of miles; between those of Venus and the earth, 27,000,000; between those of the earth and Mars, 50,000,000; but between the orbits of Mars and Jupiter there intervenes the immense space of 319,000,000 of miles. Here the order of the solar system was supposed to be interrupted, which would form an exception to the general law of the proportion of the planetary distances. No planetary body, however, was detected within this interval until the beginning of the present century; and, instead of one large body, as was surmised, four very small ones have been discovered. These bodies are situated at a distance from Mars nearly corresponding to the order and proportion to which we have now alluded; and this circumstance leads to a belief "that it is something beyond a mere accidental coincidence, and belongs to the essential structure of the system." As these bodies are invisible to the naked eye, and can only be seen in certain favorable positions, and as only a short period has elapsed since their discovery, we are not yet much acquainted with many of their phenomena and physical peculiarities.

Of these four bodies, the first discovered was that which is now named *Ceres*, and sometimes *Piazzi*, from the name of its discoverer. It was discovered at Palermo, in the island of Sicily, on the 1st of January, 1801, or the first day of the present century, by Piazzi, a celebrated astronomer belonging to that city, who has since distinguished himself by his numerous observations on the fixed stars. This new celestial body was then situ-

ated in the constellation Taurus, and, consequently, at no very great distance from its opposition to the sun. It was observed by Piazzi until the 12th of February following, when a dangerous illness compelled him to discontinue his observations; but it was again discovered by Dr. Olbers, of Bremen, after a series of unwearied observations and laborious calculations, founded on a few insulated facts which had been stated by Piazzi. Dr. Brewster states, in the "Edinburgh Encyclopedia," vol. ii, p. 638, and likewise in his second edition of "Ferguson's Astronomy," vol. ii, p. 38, "that the redisccovery of this planet by Olbers did not take place until the 1st of January, 1807;" which must be a mistake, for in "*La Decade Philosophique*," for July, 1803, it is stated that Dr. Olbers, some time before, received La Lande's prize for having discovered the planet Pallas; and, at the same time, his merit is referred to in having rediscovered Ceres; and having been among the first that announced it to the world. Beside, Sir W. Herschel has observations on this planet in the "Philosophical Transactions," of date February 7, 1802, which, of course, was posterior to Dr. Olbers' redisccovery.

The planet *Pallas*, or, as it is sometimes named, *Olbers*, was discovered on the 28th of March, 1802,—only fifteen months after the discovery of Ceres,—by Dr. Olbers, a physician at Bremen, in Lower Saxony, distinguished for his numerous celestial observations, and for his easy and commodious method of calculating the orbits of comets. The planet *Juno* was discovered on the evening of September 1, 1804, within two years and a half of the discovery of Pallas, by M. Harding, at the observatory of Lillienthal, near Bremen, while endeavoring to form an atlas of all the stars near the orbits of Ceres and Pallas, with the view of making further discoveries. While thus engaged, he perceived a small star of about the eighth magnitude, which was not marked in the Celestial Atlas of La Lande, which he put down in his chart. Two days afterward he found that the star had disappeared from the position in which he had marked it; but a little to the south-west of that position he perceived another star resembling it in size and color; and having observed it again on the 5th of September, and finding that it had moved a little in the same direction as before, he concluded that it was a moving body connected with the solar system.

The planet *Vesta* was discovered on the 29th of March, 1807, little more than two years and a half after the discovery of Juno, so that four primary planets belonging to our system, which had been hidden for thousands of years from the inhabitants of our globe, were discovered within the space of little more than six years.—Vesta must then have been near its opposition. The discovery of Vesta was made by Dr. Olbers, who had previously discovered Pallas, and rediscovered Ceres. He had formed an idea that the three small bodies lately discovered might possibly be the fragments of a larger planet, which had been burst asunder by some unknown and powerful irruptive force proceeding from its interior parts, and that more fragments might still be detected. Whether this position be tenable or not, it seems to have led to the discovery of Vesta; for the doctor concluded, if his opinions were just, that although the orbits of all these fragments might be differently inclined to the ecliptic, yet as they must all have diverged from the same point they ought to have two common points of reunion, or two nodes in opposite regions of the heavens, through which all the planetary fragments

must sooner or later pass." One of these nodes, or points of intersection of the orbits he found to be in the sign *Virgo*, and the other in the constellation of the *Whale*; and it was actually in the regions of the *Whale* that the planet *Juno* was discovered by M. Harding. With the view, therefore, of detecting other fragments, if any should exist, Dr. Olbers examined, three times every year, all the small stars in the opposite constellations of *Virgo* and the *Whale*, and in the constellation of *Virgo* the planet *Vesta* was first seen.\* This was doubtless a remarkable coincidence of theory with observation, and affords a presumption that the conjecture of this eminent astronomer may possibly have a foundation in fact.

The following is a summary of what has been ascertained respecting the distances, magnitudes, and motions of these bodies:

*The Planet Vesta.*—The mean distance of this planet from the sun is reckoned to be about 225 millions of miles; its annual revolution is completed in about 3 years  $7\frac{1}{2}$  months, or in 1325 days; the circumference of its orbit is 1414 millions of miles, and, of course, it moves with a velocity, on an average, of more than 44,000 miles an hour. The inclination of its orbit to the plane of the ecliptic is seven degrees, eight minutes; and its eccentricity 21 millions of miles. The diameter of this planet has been estimated by some astronomers at only about 270 miles; and, if this estimate be correct, it will contain only 223,000 square miles, or a surface somewhat less than Great Britain, France, and Ireland; and, according to the rate of population formerly stated, would contain 64 millions of inhabitants, or about five times the number of the inhabitants of the United States of America, or nearly the twelfth part of the population of the earth. It is probable, however, that this estimate is too small, and that the apparent diameter of this planet has not yet been accurately taken; for the light of this body is considered equal to that of a star of the fifth or sixth magnitude, and it may sometimes be distinguished, in a clear evening, by the naked

eye. Its light is more intense and white than that of either *Ceres*, *Juno*, or *Pallas*; and it is not surrounded with any nebulosity, as some of these planets are. It is not likely that a body of this size could be seen at the distance of 130 millions of miles, which is its nearest approach to the earth, and that, too, by the naked eye (as Schroeter affirms he did several times), unless the substances on its surface were of such a nature as to reflect the solar rays with a far greater degree of brilliancy than any of the other planets. The diameter of the third satellite of *Jupiter* is reckoned at 3377 miles, and its surface, of course, contains 35,827,211 square miles, which is 156 times greater than the surface of *Vesta*, according to the above estimation. Yet this satellite can never (or, at least, but rarely) be seen by the naked eye. *Vesta* is, indeed, only about one-third the distance from us of the satellite of *Jupiter*; but, making allowance for this circumstance, it should be at least twenty times larger in surface than is estimated above in order to be seen by the naked eye, or with the same distinctness as the third satellite of *Jupiter*. In other words, it should have a diameter of at least 1200 miles. If this is not the case, there must be something very peculiar and extraordinary in the reflective power of the materials which compose its surface to produce such an intensity of light from so small a body at so great a distance as 130 millions of miles. I am therefore of opinion that the size of this planet has not yet been accurately ascertained, and that future and more accurate observations are still requisite to determine its apparent diameter and real magnitude.

*The Planet Juno.*—The next planet in the order of the system is *Juno*. Its distance from the sun is estimated at 254 millions of miles. The circumference of its orbit is 1596 millions of miles. Through this circuit it moves in four years and 128 days, at the rate of 41,850 miles every hour. Its diameter, according to the estimate of Schroeter, is 1425 English miles. Its surface will therefore contain six millions, three hundred and eighty thousand square miles, and a population of one thousand, seven hundred and eighty-six millions, which is more than double the number of the earth's inhabitants. The orbit of *Juno* is inclined to the ecliptic in an angle of thirteen degrees, three minutes. Its eccentricity is 63,588,000 miles, so that its greatest distance from the sun is 316,968,000 miles, while its least distance is only 189,792,000. Its apparent diameter as seen from the earth is little more than three seconds. This planet is of a reddish color, and is free from any nebulosity; yet the observations of Schroeter render it probable that it has an atmosphere more dense than that of any of the old planets of the system. A remarkable variation in the brilliancy of this planet has been observed by this astronomer, which he attributes to changes that are going on in its atmosphere, and thinks it not improbable that these changes may arise from a diurnal rotation performed in twenty-seven hours.

*The Planet Ceres.*—This planet is about 263 millions of miles from the sun, and completes its annual revolution in four years, seven months, and ten days. The circumference of its orbit is 1653 millions of miles, and it moves at the rate of about forty-one thousand miles an hour. The eccentricity of its orbit is 20,598,000 miles. Its greatest distance from the sun is 233,590,000 miles, and its least distance 242,300,000. Its apparent mean diameter, including its atmosphere, according to Schroeter, is somewhat more than six seconds at its mean distance from the earth

\* William Olbers, M. D., the discoverer of *Vesta* and *Pallas*, was born on the 11th of October, 1758, at Arbergen, a village in the Duchy of Bremen, where his father was a clergyman. His father, beside being a man of great general learning, was a good mathematician and a lover of astronomy. Young Olbers, when in his fourteenth year, felt a great taste for that science. During an evening walk in the month of August, having observed the Pleiades, or seven stars, he became very desirous of knowing to what constellation they belonged. He therefore purchased some charts and books, and began to study this science with the greatest diligence; he read with the greatest avidity every astronomical work he was able to procure, and in a few months made himself acquainted with all the constellations. Finding that a knowledge of mathematics was necessary to the study of astronomy, he devoted all his leisure time to this subject. He was at the same time engaged in the study of medicine as a profession. In the year 1779, when scarcely twenty-one years of age, he observed at Göttingen, and calculated the first comet. An account of this labor was published in the "Berlin Astronomical Calendar" for 1782, where it is mentioned that Olbers made his construction one night while attending a patient; and yet it was afterward found that his determination of this orbit corresponded with the most accurate elements of the comet which were calculated. Since that period, the astronomy of comets has been his favorite study, and it is admitted that none of the methods formerly tried for calculating the orbit of a comet is so simple, and, at the same time, so elegant as that of Dr. Olbers. When at Vienna, amid all his applications to the study of medicine, he was the first who observed the planet *Uranus* (after its discovery by Herschel), on the 15th of August, 1781. On the 19th he perceived its motion, and continued his observations until the end of September, at which period it was considered as a comet. Returning from the scene of his studies, he settled at Bremen as a physician, where he soon acquired the confidence of his fellow-citizens, both on account of his successful practice and integrity and affability of his character.



Its real diameter, according to the estimate of the same astronomer, is 1624 English miles; but, including its atmosphere, is  $25^{\circ}4$  miles. Its surface, therefore, contains 8,275,580 square miles, or about the one-sixth part of the habitable portions of our globe; and would afford accommodation for 2,319,962,400, or more than 2300 millions of inhabitants, according to the rate of population in England, which is nearly triple the present population of the earth. This planet is of a slight ruddy color, and appears about the size of a star of the eighth magnitude, and is consequently invisible to the naked eye. It seems to be surrounded with a dense atmosphere, and exhibits a disc or sensible breadth of surface when viewed with a magnifying power of two hundred times. Schroeter has determined, from a great number of observations, that its atmosphere is about six hundred and seventy-five English miles in height, and that it is subject to numerous changes. Like the atmosphere of the earth, it is very dense near the planet, and becomes rarer at a greater distance, which causes its apparent diameter to appear somewhat variable. When this planet is approaching the earth, toward the point of its opposition to the sun, its diameter increases more rapidly than it ought to do from the diminution of its distance, which Schroeter supposes to arise from the finer exterior strata of its atmosphere becoming visible while it approaches the earth. He also perceived that the visible hemisphere of the planet was sometimes overshadowed, and at other times cleared up, so that he concludes there is little chance of discovering the period of its diurnal rotation. The inclination of its orbit to the ecliptic is in an angle of ten degrees, thirty-seven minutes. The intensity of light upon its surface is more than seven times less than what we enjoy.

Sir William Herschel, in the year 1802, after the discovery of Ceres and Pallas, made a number of observations to ascertain if any of these bodies were accompanied with satellites. Several very small stars were occasionally perceived near Ceres with high magnifying powers, of the positions and motions of which he has given several delineations; but it did not appear probable, in subsequent observations, that they accompanied the planet. In his observation of April 28, with a power of 550, he says, "Ceres is surrounded with a strong haziness. The breadth of the coma, beyond the disc, may amount to the extent of a diameter of the disc, which is not very sharply defined. Were the whole coma and star taken together, they would be at least three times as large as my measure of the star. The coma is very dense near the nucleus; but loses itself pretty abruptly on the outside, though a gradual diminution is still very perceptible." These observations seem to corroborate the idea that Ceres is encompassed with an atmosphere of great density and elevation.

*The Planet Pallas.*—This planet revolves about the sun at the mean distance of two hundred and sixty-three millions of miles, and finishes its revolution in 1681 days, 17 hours, or in four years and seven and one-third months, which is within a day of the time of the revolution of Ceres. Its distance is likewise nearly the same as that planet, and the circumference of its orbit will also be nearly the same. This planet, however, is distinguished in a remarkable degree both from Ceres and from all the other planets by the very great inclination of its orbit to the plane of the ecliptic. This inclination is no less than thirty-four degrees, thirty-seven minutes, or nearly five

times the inclination of Mercury's orbit, which was formerly reckoned to have the greatest inclination of any of the planetary orbits. The eccentricity of the orbit of Pallas is likewise greater than that of any of the other planets, being no less than 64,516,000 miles, so that this planet is 129,000,000 of miles nearer the sun in one part of its orbit than it is at the opposite extremity. Its greatest distance from the sun is 527,437,000 miles, and its least distance only 136,404,000 miles. Of course, its rate of motion in its orbit must be very variable, sometimes moving several thousands of miles an hour swifter at one time than at another, which is likewise the case, in a remarkable degree, with the planet Juno. Its mean motion is about 41,000 miles an hour.

This planet presents a ruddy aspect, but less so than that of Ceres. It is likewise surrounded with a nebulosity somewhat like that of Ceres, but of less extent. The following are some of the observations of this planet by Schroeter and Herschel. The atmosphere of Pallas, according to Schroeter, is to that of Ceres as one hundred and one to one hundred and forty-six, or nearly as two to three. It undergoes similar changes, but the light of the planet exhibits greater variations. On the 1st of April, the atmosphere of Pallas suddenly cleared up, and the solid nucleus or disc of the planet was alone visible. About twenty-four hours afterward, the planet appeared pale and surrounded with fog, and this appearance continued during the 3d and 4th of April; but this phenomenon was not considered as arising from the diurnal rotation of the planet. The following are Herschel's observations: "April 22. In viewing Pallas, I cannot, with the utmost attention and under favorable circumstances, perceive any sharp termination which might denote a disc; it is rather what I would call a nucleus. April 22. The appearance of Pallas is cometary; the disc, if it has any, being ill-defined. When I see it to the best advantage, it appears like a much-compressed, extremely small, but ill-defined planetary nebula. May 1. With a twenty-foot reflector, power 477, I see Pallas well, and perceive a very small disc, with a coma of some extent about it, the whole diameter of which may amount to six or seven times that of the disc alone."—*Philosophical Transactions* for 1802.

The diameter of this planet has not, perhaps, been ascertained with sufficient precision. The difference in the estimates formed by Sir W. Herschel and M. Schroeter is very great. According to Schroeter, the diameter of Pallas is 2099 miles. If this estimate be nearly correct, Pallas will be about the size of our moon, and will comprehend on its surface nearly fourteen millions of square miles, which would accommodate a population of nearly four thousand millions, or five times the population of our world. The apparent mean diameter of this planet, comprehending its atmosphere, at its mean distance from the earth, according to Schroeter, is six and a half seconds.

Such is a brief view of the principal facts which have been ascertained respecting the planets Vesta, Juno, Ceres, and Pallas. All these bodies are situated between the orbits of Mars and Jupiter, and they are all invisible to the naked eye, except, perhaps, the planet Vesta, when in certain favorable positions. The real magnitudes of these planets are not to be considered as yet accurately determined; they may be a little greater or less than what is stated above, though it is not probable they are much larger. It may not be improper to remark, that on this point there is a great difference in the

estimates of Schroeter and Herschel, the two principal observers who have investigated the phenomena of these planets, owing to the mode in which they measured the apparent diameters of these bodies. According to Sir W. Herschel, there is none of these bodies that exceeds 163 miles in diameter. But it is obvious, from the considerations I have stated in the description of Vesta, that bodies of such a small size could not be visible at such a distance, unless they were either luminous or composed of matter fitted to reflect the solar light with an extraordinary degree of brilliancy; and, therefore, it is far more probable that the estimates of Schroeter are nearest the truth.

*Peculiarities of the New Planets.*—These bodies present to our view various singularities and anomalies, which, at first sight, appear incompatible with the proportion and harmony which we might suppose originally to have characterized the arrangements of the solar system. In the first place, *their orbits have a much greater degree of inclination to the ecliptic than those of the old planets.* The orbit of Venus is inclined to the ecliptic in an angle of three degrees, twenty minutes; of Mars, one degree, fifty-one minutes; of Jupiter, one degree, eighteen minutes; of Saturn, two degrees and a half; and of Uranus, only forty-six minutes. But the inclination of the orbit of Vesta is seven degrees, nine minutes; of Juno, thirteen degrees; of Ceres, ten degrees, thirty-seven minutes; and of Pallas, no less than thirty-four degrees and a half, which is nineteen times greater than the inclination of Mars, and twenty-seven times greater than that of Jupiter. The proportion of these inclinations is represented in the following figure.

Fig. 46.

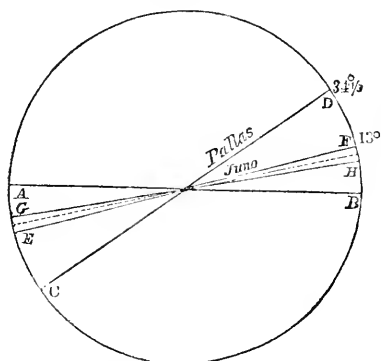

Let *AB* represent the plane of the ecliptic, and the line *CD* will represent the inclination of the orbit of Pallas =  $34\frac{1}{2}$  degrees, *EF*, the inclination of the orbit of Juno = 13 degrees; *GH*, the inclination of Vesta's = 7 degrees; and the dotted line the inclination of Ceres =  $10\frac{1}{2}$  degrees. All the older planets have their orbits much less inclined to the ecliptic, except Mercury, which has nearly the same inclination as Vesta; so that the zodiac would now require to be extended nearly five times its former breadth in order to include the orbits of all the planets.

2. *The orbits of these planets are in general more eccentric than those of the other planets;* that is, they move in longer and narrower ellipses. The following figure nearly represents the orbit of Pallas, and the orbit of Juno is nearly similar. *S* represents the sun in one of the foci of the ellipse; *C*, the center; *F*, the upper focus of the ellipse;

and the whole line *AB*, the transverse diameter. Now the distance *SC*, from the sun to the center, is the *eccentricity* of the orbit. This eccentricity,

Fig. 47.

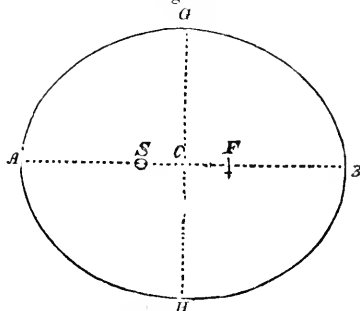

in the case of Pallas, amounts to more than sixty-four and a half millions of miles. Consequently, when the planet is at *B*, which is called its *Aphelion*, or greatest distance from the sun, it is double its eccentricity, or the whole length of the line *SF* farther from the sun than when it is at the point *A*, which is called its *Perihelion*, or least distance from the sun, that is, it is 129 millions of miles farther from the sun in the one case than in the other, which is nearly *one-fourth* of the whole transverse diameter of the orbit *AB*. Consequently, its motion will be much slower, by several hundreds of thousands of miles a day, when near the point *B*, its aphelion, than when near its perihelion at the point *A*; and to a spectator on its surface the sun will appear more than double the size from the point *A* that he does from the point *B*; and its inhabitants (if any) will experience a greater difference in the intensity of the solar light which falls upon them in different periods of its year, than there is between Venus and the earth, or between the earth and Mars. On the other hand, the eccentricity of the orbits of the older planets is comparatively small. The eccentricity of the orbit of Venus is less than half a million of miles, which is only the 1-274th part of the transverse diameter of its orbit. The Earth's eccentricity is 1,618,000, or the 1-119th part; Jupiter's, 1-43d part; Saturn's, 1-38th part; and that of Uranus, about 1-13d part; whereas, the eccentricities of Pallas and Juno amount to nearly *one-eighth* part of the transverse axes of their orbits. Were the orbits of the old planets represented by figures ten times larger than the above diagram, they could not be distinguished from circles. In the above figure, the dotted line *GH* is the *conjugate* or shorter diameter of the ellipse. When the planet is at the points *G* and *H*, it is said to be at its *mean distance* from the sun, or at the middle point between its greatest and its least distance.

3. *The Orbits of several of the New Planets cross each other.*—This is a very singular and unaccountable circumstance in regard to the planetary orbits. It had been long observed that comets, in traversing the heavens in every direction, crossed the orbits of the planets; but, before the discovery of Pallas, no such anomaly was found throughout the system of the planets. For the orbits of all the other planets approach so nearly to circles, and are separated from each other by so many millions of miles, that there is no possibility of such intersection taking place. The following diagram represents the intersection of the orbits of Ceres and Pallas.

The central circle represents the sun; the two

new circles the orbits of the earth and Mars; and the two outer circles, crossing each other, those

Fig. 48.

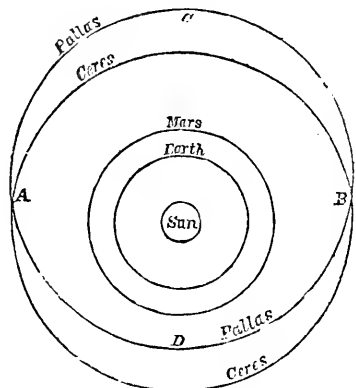

of Ceres and Pallas. In consequence of this intersection of their orbits, there is a possibility, especially if the periods of their revolutions were somewhat more different from each other, that the two planets might happen to strike against each other were they to meet at the points A and B, where the orbits intersect; a very singular contingency in the planetary system. It is owing to the very great eccentricity of the orbit of Pallas that it crosses the orbit of Ceres. It is several millions of miles nearer the sun in its perihelion (or at A, Fig. 47) than Ceres, when in the same point of its orbit. But when Pallas is in its aphelion (or at B, Fig. 47); its distance from the sun is several millions of miles greater than that of Ceres in the same point of its orbit. Suppose its aphelion at C, Fig. 48; it is further from the sun than Ceres, and nearer at D its perihelion. The same things happen in the case of the other two planets, particularly Vesta. Juno is further from the sun at its aphelion than Ceres in the same point of its orbit, and Vesta is further from the sun in its aphelion than either Juno, Ceres, or Pallas, in their perihelions. The perihelion distance of Vesta is greater than that of Juno or Pallas. Hence it follows that Vesta may sometimes be at a greater distance from the sun than either Juno, Ceres, or Pallas, although its mean distance is less than that of either of them by twenty-eight millions of miles; so that the orbit of Vesta crosses the orbits of all the other three, and, therefore, it is a possible circumstance that a collision might take place between Vesta and any of these three planets, were they ever to meet at the intersection of their orbits. Were such an event to happen, it is easy to foresee the catastrophe that would take place. If the collision of two large slips, sailing at the rate of ten miles an hour, be so dreadful as to shatter their whole frame and sink them in the deep, what a tremendous shock would be encountered by the impulse of a ponderous globe, moving at the rate of forty thousand miles an hour? A universal disruption of their parts and a derangement of their whole constitution would immediately ensue; their axes of rotation would be changed; their courses in their orbits altered; fragments of their substance tossed about through the surrounding void, and the heavens above would appear to run into confusion. Though we cannot affirm that such an event is impossible or will never happen, yet we are sure it can never take place without the per-

mission and appointment of Him who at first set these bodies in motion, and who superintends both the greatest and the most minute movements of the universe.

4. Another peculiarity in respect to these planets is, that they revolve nearly at the same mean distances from the sun. The mean distance of Juno is 254 millions of miles; that of Ceres, 262,903,000; and that of Pallas, 262,901,000, which is almost the same as Ceres. This is a very different arrangement from that of the other planets, whose mean distances are immensely different from each other; Mars being 50 millions of miles from the orbit of the earth, and 89 millions from the orbits of any of the new planets; Jupiter, 270 millions from Pallas; Saturn, 412 millions from Jupiter; and Uranus, 900 millions from Saturn. Except in the case of the new planets, the planetary system appears constructed on the most ample and magnificent scale, corresponding to the unlimited range of infinite space of which it forms a part.

5. These new planetary bodies perform their revolutions in nearly the same periods. The period of Vesta is 3 years,  $7\frac{1}{2}$  months; that of Juno, 4 years,  $4\frac{1}{2}$  months; of Ceres, 4 years,  $7\frac{1}{2}$  months; and of Pallas, 4 years,  $7\frac{1}{2}$  months. So that there are only three months of difference between the periods of Juno and Ceres, and scarcely the difference of a single day between those of Ceres and Pallas; whereas, the periods of the other planets differ as greatly as their distances. The period of Mercury is about 3 months; of Venus,  $7\frac{1}{2}$  months; of Mars, nearly 2 years; of Jupiter, 12 years; of Saturn,  $29\frac{1}{2}$ ; and of Uranus, nearly 84 years. A planet moving round the sun in almost the same period and at the same distance as another, is a singular anomaly in the solar system, and could scarcely have been surmised by former astronomers.

6. Another singularity is, that these bodies are all much smaller than the other planets. Mercury was long considered as the smallest primary planet in the system, but it is nearly four times larger in surface than Ceres, and contains eight times the number of solid miles. Mars, the next smallest planet, is seventeen times larger than Ceres; and Jupiter, the largest of the planets, is 170,000 times larger than Ceres, when their cubical contents are compared. The planets Vesta and Juno are smaller than Ceres, and Pallas is only a small degree larger. It is probable that all these four bodies are less in size than the secondary planets, or the satellites of Jupiter, Saturn, and Uranus.

*Conclusions respecting the Nature of the New Planets.*—The anomalies and peculiarities of these bodies, so very different from the order and arrangement of the older planets, open a wide field for reflection and speculation. Having been accustomed to survey the planetary system as a scene of proportion, harmony, and order, we can scarcely admit that these bodies move in the same paths, and are arranged in the same order as when the system was originally constructed by its Omnipotent Contriver. As we know that changes have taken place in our sublunary region since our globe first came from the hands of its Creator, so it is not contrary either to reason or observation to suppose that changes and revolutions, even on an ample scale, may take place among the celestial orbs. We have no reason to believe in the "incorruptibility" of the heavenly orbs, as the ancients imagined, for the planets are demonstrated to be opaque globes as well as the earth; they are diversified with mountains and vales, and, in all probability, the materials which

compose their surfaces and interior are not very different from the substances which constitute the component parts of the earth. I have already alluded to the opinion of Dr. Olbers, that the new planets are only the fragments of a larger planet which had been burst asunder by some immense irruptive force proceeding from its interior parts. However strange this opinion may at first sight appear, it ought not to be considered as either very improbable or extravagant. We all profess to admit, on the authority of Revelation, that the earth was arranged in perfect order and beauty at its first creation; and on the same authority we believe that its exterior crust was disrupted, that "the cataracts of heaven were opened, and the fountains of the great deep broken up," and that a flood of waters ensued which covered the tops of the loftiest mountains, which transformed the earth into one boundless ocean, and buried the immense myriads of its population in a watery grave. This was a catastrophe as tremendous and astonishing as the bursting asunder of a large planet. Although physical agents may have been employed in either case to produce the effect, yet we must admit, in consistency with the Divine perfections, that no such events could take place without the direction and control of the Almighty, and that, when they do happen, whatever appalling or disastrous effects they may produce, they are in perfect consistency with the moral laws by which his universal government is directed.

We know that a moral revolution has taken place among the human race since man was created, and that this revolution is connected with most of the physical changes that have happened in the constitution of our globe; and, if we believe the sacred historian, we must admit that the most prominent of these physical changes or convulsions was the consequence or punishment of man's alienation from God and violation of his laws. As the principles of the Divine government must be essentially the same throughout every part of the boundless empire of the Almighty, what should hinder us from concluding that a moral cause, similar to that which led to the physical convulsions of our globe, may have operated in the regions to which we allude, to induce the Governor of the universe to undermine the constitution, and to dash in pieces the fabric of that world? The difference is not great between bursting a planet into a number of fragments and cleaving the solid crust of the earth asunder, removing rocks and mountains out of their place, and raising the bed of the ocean from the lowest abyss, so as to form a portion of elevated land; all which changes appear to have been effected in the by-past revolutions of our globe, and both events are equally within the power and the control of Him "who rules in the armies of heaven, and among the inhabitants of the earth," whatever physical agents he may choose to select for the accomplishment of his purposes. In the course of the astronomical discoveries of the two preceding centuries, views of the universe have been laid open which have tended to enlarge our conceptions of the attributes of the Deity, and of the magnificence of that universe over which he presides; and who knows but that the discovery of those new planets described above, and the singular circumstances in which they are found, are intended to open to our view a new scene of the physical operations of the Creator, and a new display of the operations of his moral government? For all the manifestations of God in his works are doubtless intended to produce on the mind not only an intellectual, but also a moral

effect; and in this view the heavens ought to be contemplated with as much reverence as the revelations of his word. As the great Sovereign of the universe is described by the inspired writers as being the "King Eternal and Invisible," so we can trace his perfections and the character of his moral government only, or chiefly, through the medium of those displays he gives of himself in his wonderful operations both in heaven and on earth. And since in the course of his providence, he has crowned with success the inventive genius of man, and led him on to make the most noble discoveries in reference to the amplitude and grandeur of his works, we have every reason to conclude that such inventions and such discoveries, both in the minute parts of creation and in the boundless sphere of the heavens, are intended to carry forward the human mind to more expansive views of his infinite attributes, of the magnificence of his empire, and of the *moral economy* of the government which he has established throughout the universe.

The hypothesis of the bursting of a large planet between Mars and Jupiter accounts in a great measure, if not entirely, for the anomalies and apparent irregularities which have been observed in the system of the new planets; and if this supposition be not admitted, we cannot account, on any principle yet discovered, for the singular phenomena which these planets exhibit. Sir David Brewster, who has entered into some particular discussions on this subject, after stating the remarkable coincidences between this hypothesis and actual observation, concludes in the following words: "These singular resemblances in the motions of the greater fragments and in those of the lesser fragments, and the striking coincidence between theory and observation in the eccentricity of their orbits, in their inclination to the ecliptic, in the position of their nodes, and in the places of their aphelia, are phenomena which could not possibly result from chance, and which concur to prove, with an evidence amounting almost to demonstration, that the four new planets have diverged from one common node, and have therefore composed a single planet."

Another species of phenomena, in which a great mystery still hangs, might be partly elucidated were the above hypothesis admitted, and that is the singular but not well-attested fact of large masses of solid matter falling from the higher regions of the atmosphere, or what are termed *meteoric stones*. Few things have puzzled philosophers more than to account for large fragments of compact rocks proceeding from regions beyond the clouds, and falling to the earth with great velocity. These stones sometimes fall during a cloudy, and sometimes during a clear and serene atmosphere; they are sometimes accompanied with explosions, and sometimes not. The following statements, selected from respectable authorities, will convey some idea of the phenomena peculiar to these bodies. The first description I shall select is given by J. L. Lyons, Esq., F. R. S., and contained in the "Transactions of the Royal Society." It is entitled, "Account of the Explosion of a Meteor, near Benares, in the East Indies, and of the falling of some Stones at the same time." The following are only the leading particulars. "A circumstance of so extraordinary a nature as the fall of stones from the heavens could not fail to excite the wonder and to attract the attention of every inquisitive mind. On the 19th of December, 1798, about eight o'clock in the evening, a very luminous meteor was observed in the heavens by the inhabitants of Benares and

the parts adjacent, in the form of a large ball of fire; it was accompanied by a loud noise resembling thunder, and a number of stones fell from it about fourteen miles from the city of Benares. It was observed by several Europeans, as well as natives, in different parts of the country. It was likewise very distinctly observed by several European gentlemen and ladies, who described it as a large ball of fire, accompanied with a loud rumbling noise not unlike an ill-discharged platoon of musketry. It was also seen and the noise heard by several persons at Benares. When a messenger was sent next day to the village near which they had fallen, he was told that the natives had either broken the stones to pieces, or given them to the native collector or others. Being directed to the spot where they fell, he found four, most of which the fall had buried six inches deep in the earth.—He learned from the inhabitants that, about eight o'clock in the evening, when retired to their habitations, they observed a very bright light, proceeding as from the sky, accompanied with a loud clap of thunder, which was immediately followed by the noise of heavy bodies falling in the vicinity. They did not venture out to make any inquiries until next morning, when the first circumstance that attracted their attention was the appearance of the earth being turned up in several parts of their fields, where, on examination, they found the stones. Several other stones of the same description were afterward found by different persons. One of these stones, of about two pounds' weight, fell through the top of the watchman's hut, close to which he was standing, and buried itself several inches in the floor, which was of consolidated earth. The form of the more perfect stones appeared to be that of an irregular cube, rounded off at the edges, but the angles were to be observed on most of them. At the time when the meteor appeared the sky was perfectly serene; not the smallest vestige of a cloud had been seen since the 11th of the month, nor were any observed for many days after. It is well known there are no volcanoes on the continent of India, and therefore they could not derive their origin from any such source; and no stones have been met with in the earth, in that part of the world, which bear the smallest resemblance to those now described.\*

On the 13th of December, 1795, a stone weighing fifty-six pounds fell near Wold cottage, in Yorkshire, at three o'clock, P. M. It penetrated through twelve inches of soil and six inches of solid chalk rock, and, in burying itself, had thrown up an immense quantity of earth to a great distance; as it fell, a number of explosions were heard as loud as pistols. In the adjacent villages the sound was heard as of great guns at sea; but at two adjoining villages the sounds were so distinct of something passing through the air to the residence of Mr. Topham, that five or six people came up to see if anything extraordinary had happened at his house. When the stone was extracted, it was warm, smoked, and smelt very strong of sulphur. The day was mild and hazy, but there was no thunder nor lightning the whole day. No such stone is known in the country, and there is no volcano nearer than Vesuvius or Hecla. The constituent parts of this stone were found exactly the same as those of the stones from Benares.\*

On the 26th of April, 1803, an extraordinary

shower of stones happened at L'Aigle, in Normandy. About one o'clock, the sky being almost serene, a rolling noise like that of thunder was heard, and a fiery globe of uncommon splendor was seen, which moved through the atmosphere with great rapidity. Some moments after there was heard at L'Aigle, and for thirty leagues around in every direction, a violent explosion, which lasted five or six minutes; after which was heard a dreadful rumbling like the beating of a drum. In the whole district there was heard a hissing noise like that of a stone discharged from a sling, and a great many mineral masses, exactly similar to those distinguished by the name of *meteor stones*, were seen to fall. The largest of these stones weighed seventeen pounds and a half. The Vicar of St. Michael's observed one of the stones fall with a hissing noise at the feet of his niece in the courtyard of his parsonage, and that it rebounded more than a foot from the pavement.—When it was taken up and examined, it was found to resemble the others in every respect. As a wire manufacturer was working with his men in the open air, a stone grazed his arm and fell at his feet, but it was so hot that, on attempting to take it up, he instantly let it fall again. The celebrated Biot was deputed by government to repair to the spot and collect all the authentic facts in relation to this phenomenon, an account of which was afterward published in a long memoir. He found that almost all the residents of twenty hamlets declared that they were eyewitnesses of the shower of stones which was darted from the meteor.—The interior parts of these stones resembled those of all the meteorites analyzed by Messrs. Howard and Vauquelin, such as those described above. They all contain silica, magnesia, oxyd of iron, nickel, and sulphur, in various proportions.—Their specific gravity is about three and one-third or three and one-half times heavier than water.

The following are a few brief statements in relation to this subject. In 1492, November 7, a stone of 260 lbs. fell at Ensisheim, in Alsace. It is now in the library of Colmar, and has been reduced to 150 lbs., in consequence of the abstraction of fragments. The famous Gassendi relates that a stone of a black metallic color fell on Mount Vaision, in Provence, November 29, 1637. It weighed 54 lbs., and had the size and shape of the human head. Its specific gravity was three and one-half times that of water. 1654, March 30: A small stone fell at Milan and killed a Franciscan. 1706, June 7: A stone of 72 lbs. fell at Larissa, in Macedonia; it smelled of sulphur, and was like the scum of iron. 1751, May 26: Two masses of iron, of 71 lbs. and 16 lbs., fell in the district of Agram, the capital of Croatia. The largest of these is now in Vienna. 1790, July 24: A great shower of stones fell at Barbotan, near Rounefort, in the vicinity of Bourdeaux. A mass fifteen inches in diameter, penetrated a hut and killed a herdsman and a bullock. Some of the stones weighed 25 lbs., and others 30 lbs. July, 1810: A large ball of fire fell from the clouds at Shahabad, which burned five villages, destroyed the crops, and killed several men and women. November 23, 1810: Three stones fell in the commune of Charionville and neighborhood of Orleans. These stones were precipitated perpendicularly, and without the appearance of any light or ball of fire. One of them weighed 20 lbs., and made a hole in the ground in a perpendicular direction, driving up the earth to the height of eight or ten feet. It was taken out half an hour after, when it was still so hot that it could scarcely be

\* See a long paper on this subject, by E. Howard, Esq., F. R. S. in "Transactions of the Royal Society of London" for 1802.

held in the hand. The second formed a hole three feet deep, and weighed 40 lbs. 1812, April 15: A stone, the size of a child's head, fell at Erxleben, and a specimen of it is in the possession of Professor Haussmann, of Brunswick. 1814, September 1: A few minutes before midday, while the sky was perfectly serene, a violent detonation was heard in the department of the Lot and Garonne. This was followed by three or four others, and finally by a rolling noise, at first resembling a discharge of musketry, afterward the rumbling of carriages, and, lastly, that of a large building falling down. Stones were immediately after precipitated to the ground, some of which weighed 18 lbs., and sank into a compact soil to the depth of eight or nine inches, and one of them rebounded three or four feet from the ground.—1818, July 29, O. S.: A stone of 7 lbs. weight fell at the village of Slobodka, in Russia, and penetrated nearly sixteen inches into the ground. It had a brown crust with metallic spots. In 1825, February 10: A meteoric stone weighing 16 lbs. 7 oz., fell from the air at Nanjemoy, Maryland.—It was taken from a ground about half an hour after its fall, was sensibly warm, and had a sulphurous smell.

Several hundreds of instances similar to the above might be produced of large masses of stones having fallen from the upper regions upon the earth.\* These stones, although they have not the smallest analogy with any of the mineral substances already known, either of a volcanic or any other nature, have a very peculiar and striking analogy with each other. They have been found at places very remote from each other, and at very distant periods. The mineralogists who have examined them agree that they have no resemblance to mineral substances, properly so called, nor have they been described by mineralogical authors. They have, in short, a peculiar aspect, and peculiar characters which belong to no native rocks or stones with which we are acquainted. They appear to have fallen from various points of the heavens, at all periods, in all seasons of the year, at all hours both of the day and night, in all countries in the world, on mountains and on plains, and in places the most remote from any volcano. The luminous meteor which generally precedes their fall is carried along in no fixed or invariable direction; and as their descent usually takes place in a calm and serene sky, and frequently in cloudless weather, their origin cannot be traced to the causes which operate in the production of rain, thunder-storms, or tornadoes.

From a consideration of these and many other circumstances, it appears highly probable, if not absolutely certain, that these substances proceed from regions far beyond the limits of our globe. That such solid substances, in large masses, could be generated in the higher regions of the atmosphere, is an opinion altogether untenable, and is now generally discarded, even by most of those philosophers who formerly gave it their support. That they have been projected from volcanoes is a hypothesis equally destitute of support; for the products of volcanoes are never found at any great distance from the scene of their formation, and the substances they throw out are altogether different in their aspect and composition from meteoric stones. Beside, these stones, in most instances, have descended to the earth in places

removed hundreds, or even thousands of miles from any volcanic mountain, and at times when no remarkable eruption was known to take place. Perceiving no probability of their having their origin either in the earth or the atmosphere, Dr. Hutton, Poisson, La Place, and others, conjectured that they were projected from the moon. They demonstrated the abstract proposition, that a heavy body projected with a velocity of six thousand feet in a second, may be carried beyond the sphere of the moon's attraction, and come within the attraction of the earth. But it has never yet been proved that volcanoes exist on the surface of the moon; and, although they did exist, and were as large and powerful as terrestrial volcanoes, they would have no force sufficient to carry large masses of stone with such a rapid velocity over a space of several thousands of miles. Beside, were the moon the source of meteoric stones, ejected from the craters of volcanoes, we should expect such volcanic productions to exhibit several varieties of aspect and composition, and not the precise number of ingredients which are always found in meteoric stones.—From a consideration of the difficulties attending this hypothesis, La Place was afterward induced to change his opinion.

In order to trace the origin of meteoric stones, we are therefore under the necessity of directing our views to regions far beyond the orbit of the moon. On the supposition that the bursting of a large planet was the origin of the small planets Vesta, Juno, Ceres, and Pallas, we may trace a source whence meteoric stones probably originate. When the cohesion of the planet was overcome by the action of the explosive force, a number of little fragments, detached along with the greater masses, would, on account of their smallness, be projected with very great velocity; and, being thrown beyond the attraction of the greater fragments, might fall toward the earth when Mars happened to be in the remote part of his orbit. When the portions which are thus detached arrive within the sphere of the earth's attraction, they may revolve round that body at different distances, and may fall upon its surface, in consequence of a diminution of their centrifugal force; or, being struck by the electric fluid, they may be precipitated upon the earth, and exhibit all those phenomena which usually accompany the descent of meteoric stones." This opinion appears to have been first broached by Sir David Brewster, and is stated and illustrated in the "Edinburgh Encyclopedia," article *Astronomy*, and in vol. ii. of his edition of "Ferguson's Astronomy." Though not unattended with difficulties, it is perhaps the most plausible hypothesis which has yet been formed to account for the extraordinary phenomena of heavy substances falling with velocity upon the earth through the higher regions of the atmosphere.

On this subject I would consider it as premature to hazard any decisive opinions. I have laid down the above facts before the reader that he may be enabled to exercise his own judgment and form his own conclusion. I have stated them particularly with this view, that they may afford a subject of investigation and reflection. For all the works and dispensations of the Almighty, both in the physical and moral world, are worthy of our contemplation and research, and may ultimately lead both to important discoveries and to moral instruction. Though "the ways of God" are, in many instances, "past finding out," yet it is our duty to investigate them so far as our knowledge and limited powers will permit. For

\* For more particular details on this subject, the reader may consult "The Edinburgh Encyclopedia," art. *Meteorite*. "The Edin. Phil. Journl.," No. 2, p. 221-225. "Phil. Magazine," vol. xii. "Retrospect of Philosophical Discoveries," 1865, vol. 1, p. 201-210, &c., &c.

as we are told, on the highest authority, that "the works of the Lord are great and marvelous," so it is declared that "they will be sought out" or investigated "by all those who have pleasure therein." There is, perhaps, no fact throughout the universe, however minute in itself, or however distant from the scene we occupy, but is calculated, when properly considered, to convey to the mind an impression of the character of the Deity and of the principles of his moral government. The mere philosopher may content himself with the application of the principles of chemistry and mathematics to the phenomena of matter and motion; and it is highly proper and necessary that both chemical and mathematical analysis be applied for the investigation of the laws and order of the material universe; but the man who recognizes the principles of Divine Revelation will rise to still higher views. From nature he will ascend to nature's God, and trace the invisible perfections of the Eternal from the visible scene of his works; and, from his physical operations, will endeavor to learn something of the order and economy of his moral administration.

If there be any foundation for the hypothesis to which we have adverted, it might be a question and a subject of consideration at what period the disruption of the supposed planet may have taken place. If the history of the fall of meteoric stones would be considered as throwing any light on this question, it will follow that such an event must have taken place at a very distant period; for the descent of such stones can be traced back to periods more than a thousand years before the commencement of the Christian era; perhaps even to the days of Joshua, when a shower of stones destroyed the enemies of Israel,\* which would lead us to conclude that more than three thousand years must have elapsed since such an event. It might likewise be a subject of inquiry, why the Deity has exposed the earth to the impulse of such ethereal agents; for the fall of meteoric stones is evidently attended with imminent danger to the inhabitants of those places on which they fall. The velocity and impetus with which they descend are sufficient to cause instant death to those whom they happen to strike, and even to demolish human habitations, as happened in several of the instances above recorded. Would the Deity have permitted a world peopled with innocent beings to be subjected to such accidents and dangers? If not, is it not a presumptive proof that man, in being exposed to such casualties from celestial agents, as well as from storms, earthquakes, and volcanoes, is not in that state of primal innocence in which he was created? And if we suppose that a moral revolution was the cause of the catastrophe which happened to the planet to which we allude, we may trace both a physical and a moral connection, however distant, between the earth and that planet; for if the stones to which we allude are a part of the wreck of that world, they have been the means of exciting alarm among various tribes of the earth's population, and of producing destruction and devastation; so that one depraved world has been the instrument in some degree of punishing another.

But perhaps I have gone too far in such speculations. I have stated them with the view of

showing that we might occasionally connect our moral views of the Deity with the contemplation of the material fabric of the universe. When, through the medium of our telescopes and our physical investigations, we obtain a glimpse of the order and economy of a distant region of the universe, it may be considered as a new manifestation of the Deity, and it is our duty to deduce from it those instructions it is calculated to convey. And although we may occasionally deduce erroneous conclusions from existing facts, yet such speculations and reflections may sometimes have a tendency to excite an interesting train of thought, and to inspire us with an ardent desire of beholding the scene of the universe and the plan of the Divine administration more completely unfolded, in that world where the physical and moral impediments which now obstruct our intellectual vision shall be forever removed.

#### VI. ON THE PLANET JUPITER.

Next to Pallas, in the order of the system, is the planet Jupiter. This planet, when nearest the earth, is the most splendid of all the nocturnal orbs, except Venus and the moon. Its distance from the sun is 495,000,000 of miles, and the circumference of its orbit, 3,110,000,000 of miles. Around this orbit it moves in eleven years and three hundred and fifteen days, at the rate of nearly thirty thousand miles every hour. When nearest to the earth, at the time of its opposition to the sun, it is about 400,000,000 of miles distant from us. A faint idea of this distance may be acquired by considering that a cannon-ball, flying five hundred miles every hour, would require more than ninety-one years to pass over this space; and a steam-carriage, moving at the rate of twenty miles an hour, would require nearly two thousand three hundred years before it could reach the orbit of Jupiter. When at its greatest distance from the earth, about the time of its conjunction with the sun, this planet is distant from us no less than 590,000,000 of miles; yet its apparent size, in this case, does not appear very much diminished, although it is 190,000,000 of miles farther from us in the latter case than in the former. When viewed with a telescope, however, it appears sensibly larger and more splendid at the period of its opposition than when near the point of its conjunction.

*Diurnal Rotation.*—This planet has been found to revolve around its axis in the space of nine hours, fifty-five minutes, and forty-nine and a half seconds. This discovery was made by observing a small spot in one of the belts, which appeared gradually to move across the disc of the planet. Mr. Hook appears to have first observed it in the year 1664; and in the following year, 1665, Cassini, that accurate observer of the heavens, perceived the same spot, which appeared round, and moved with the greatest velocity when in the middle, but was narrower, and moved more slowly as it approached nearer the edge of the disc, which showed that the spot adhered to the body of Jupiter, and was carried round upon it. This spot continued visible during the following year, so that Cassini was enabled to determine the period of Jupiter's rotation to be nine hours and nearly fifty-six minutes. This rotation is far more rapid than that of any of the other planets, so far as we know, and nearly equals the velocity of Jupiter in his annual course round the sun. The circumference of this planet is 278,600 miles, and, therefore, its equatorial parts will move with a velocity of 28,000 miles an hour, which is

\* These stones, in our translation of the Bible, are called *hailstones*, but without any reason, since the original word, *abentim*, signifies stones in general according to the definition given in Parkhurst's Hebrew Lexicon; and in the book of Job, chap. xxviii. 3. the word is translated *stones of darkness*; meaning, undoubtedly, metallic stones or metals which are searched out from the bowels of the earth.

3000 miles more than the equatorial parts of the earth's surface move in twenty-four hours. This rapid velocity of the tropical regions of Jupiter, and of the places which lie adjacent to them, will have the effect of rendering all bodies *lighter* than they would be were the motion of rotation as slow as that of the earth. The gravity of bodies at the surface of Jupiter is more than twice as great as at the surface of the earth, on account of his superior bulk; so that a body weighing one pound at the equatorial surface of the earth would weigh two pounds four ounces and a half at the surface of Jupiter. If, therefore, we were transported to the surface of that planet, we should be a burden to ourselves, being pressed down with more than double our present weight, and having but the same strength to support it. But Jupiter is eleven times larger in circumference than the earth; and hence, if both planets revolved on their axes in the same time, the centrifugal force on Jupiter would be eleven times greater than with us. But the squares of the number of revolutions performed in the same time by the earth and Jupiter; that is, the square of twenty-four hours, and the square of nine hours, fifty-six minutes, are nearly as one to six; therefore, a body placed on Jupiter will have sixty-six\* times a greater centrifugal force than with us, which would sensibly relieve the weight of the inhabitants if they stood in need of it. This rapid rotation would of itself relieve them of one-eighth or one-ninth of their whole weight; or, in other words, a body weighing eight stone at the equator of Jupiter, if the planet stood still, would gravitate with a force of only seven stone on the commencement of its diurnal rotation, at the rate at which we now find it.

It may perhaps be surmised by some that, since the semidiameter of Jupiter is eleven times greater than that of the earth, the attraction or weight of bodies on its surface ought to be eleven times greater than on the surface of our globe. This would be the case if the matter in Jupiter were as dense as in the earth; and the weight of bodies would, of course, be in proportion to their semidiameter, or the distance of the surface from the centers of these bodies. But the density of Jupiter is only a little more than that of water, while the density of the earth is five times greater. If the density of Jupiter were as great as that of the earth, and, consequently, the weight of bodies on its surface eleven times greater, men of our stature and make could scarcely be supposed to support eleven times the weight of such bodies as ours, but behooved to be almost chained down to the surface of the planet by their own gravity; and were we to suppose them of a larger stature, this inconvenience would become the greater; for the least of any species of animated beings have generally the greatest nimbleness and agility of motion. This circumstance is perhaps one of the reasons why the larger planets of the system have the least degree of density: for if Jupiter were composed of materials as dense as those of Mercury, organized beings like man would be unable, without a supernatural power, to traverse the surface of such a planet.

In consequence of the rapid motion of Jupiter, the days and nights will be proportionably short. The sun will appear to move through the whole celestial hemisphere, from the eastern to the western horizon, in less than five hours, and all the planets and constellations will appear to move with the same rapidity: so that the apparent mo-

tions of all these bodies will be perceptible to the eye when contemplating them only for a few moments, excepting those which appear near the polar regions. The sky of this planet will, therefore, assume an air of sublimity superior to ours, in consequence of all the bodies it contains appearing to sweep so rapidly around, and to change their positions in so short a space of time. As Jupiter moves round the sun in 4332 $\frac{1}{2}$  of our days, and round its axis in nine hours, fifty-six minutes, there will be 10,470 days in the year of that planet.

*Magnitude and Superficial Contents of the Globe of Jupiter.*—This planet is the largest in the system, being 89,000 miles in diameter, and, consequently, fourteen hundred times larger than the earth. Its surface contains 24,884,000,000, or twenty-four thousand eight hundred and eighty-four millions of square miles, which, at the rate of population formerly stated, 280 inhabitants to a square mile, would be sufficient for the accommodation of 6,967,520,000,000, or nearly seven billions of inhabitants, which is more than eight thousand seven hundred times the present population of our globe, and nearly fifty times the number of human beings that have existed on the earth since its creation. Although the one-half of this planet were covered with water, which does not appear to be the case, it would still be ample enough to contain a population more than four thousand times larger than that of our globe. If such a population actually exist, as we have little reason to doubt, it may hold a rank, under the Divine government, equal to several thousands of worlds such as ours. Such an immense globe, replenished with such a number of intellectual beings, revolving with such amazing rapidity round its axis, moving forward in its annual course 30,000 miles every hour, and carrying along with it four moons larger than ours to adorn its firmament, presents to the imagination an idea at once wonderful and sublime, and displays a scene of wisdom and omnipotence worthy of the infinite perfections of its Creator.

*Discoveries which have been made in relation to Jupiter by the Telescope.*—Jupiter presents a splendid and interesting appearance when viewed with a powerful telescope. His surface appears much larger than the full moon to the naked eye; his disc is diversified with darkish stripes; his satellites appear sometimes in one position and sometimes in another, but generally in a straight line with each other. Sometimes two of them are seen on one side of the planet and two on another; sometimes two only are visible, while the other two are eclipsed either by the disc or the shadow of Jupiter; and sometimes all the four may be seen on one side and in a straight line from the planet, in the order of their distances; so that these moons present a different aspect and relation to each other every successive evening.

These moons were first seen by Galileo, in the year 1610, by means of a telescope he had constructed, composed of two glasses, a concave next the eye, and a convex next the object, which magnified about thirty-three times. No further discoveries were made in relation to this planet until about the year 1633, when the *belts* were discovered by Fontana Rheita, Riccioli, and several others. They were afterward more particularly observed and delineated by Cassini. These belts appear like dark stripes across the disc of the planet, and are generally parallel to one another and to the planet's equator. They are somewhat variable, however, both as to their number and their distance from each other, and

\* That is,  $11 \times 6 = 66$ .



sometimes as to their position. On certain occasions eight have been seen at a time; at other times only one. Though they are generally parallel to one another, yet a piece of a belt has been seen in an oblique position to the rest, as in Fig. 49. They also vary in breadth; for one belt has been observed to have grown a good deal narrower than it was, when a neighboring belt has been increased in breadth, as if the one, like a fluid, had flowed into the other. In favor of this opinion, it is stated in the "Memoirs of the Royal Academy of Sciences," that a part of an oblique belt was observed to lie so as to form a communication between them, as represented in Fig. 49. At one time, says Dr. Long, the belts have continued without sensible variations for nearly three months; at another time a new belt has been formed in an hour or two. They have sometimes been broken up and distributed over the whole face of the planet, in which state they are exhibited in some of the delineations of Sir W. Herschel; but this phenomenon is extremely rare, and does not appear to have been noticed by any other observer. In the year 1787, Schroeter saw two dark belts in the middle of Jupiter's disc; and near to them two white and luminous belts, resembling those which were seen by Campani in 1664. The equatorial zone which was comprehended between the two dark belts had assumed a dark gray color, bordering upon yellow. The northern dark belt then received a sudden increase of size, while the southern one became partly extinguished, and afterward increased into an uninterrupted belt. The luminous belts also suffered several changes, growing sometimes narrower, and sometimes one-half larger than their original size.

The following figures represent some of the appearances of the belts of Jupiter.

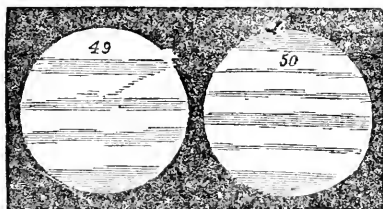
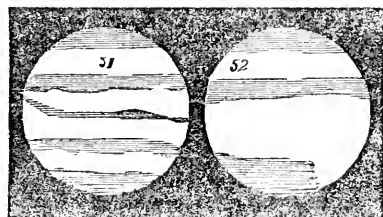
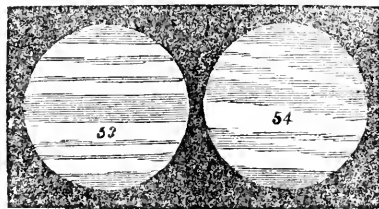

Fig. 49, represents a view of Jupiter's belts by Cassini. Fig. 50, a view from Dr. Hook, as delineated in the "Philosophical Transactions" for 1666, which was taken by a sixty feet refracting telescope. The small black spot on the middle belt, which did not appear at the beginning of the observation, and which moved about a third or fourth part across the disc in the space of ten minutes, was judged to be the shadow of one of the satellites moving across the disc of the planet. Fig. 51, exhibits a view of Jupiter as he



appeared about the end of 1832 and the beginning of 1833, which was taken by means of an

achromatic telescope, with magnifying powers of 150 and 180 times. Fig. 52, is a view taken with the same telescope in 1837. In this view the principal belt near the planet's equator appeared dark, distinct, and well-defined; but the other two belts at either pole were extremely faint, and could only be perceived after a minute inspection. Fig. 53, is a view in which a bright



and a dark spot were perceived on one of the belts; and Fig. 54, a view by Sir John Herschel. I have had an opportunity of viewing Jupiter with good telescopes, both reflecting and achromatic, for twenty or thirty years past; and, among several hundreds of observations, I have never seen above four or five belts at one time.—The most common appearance I have observed is that of two belts, distinctly marked, one on each side of the planet's equator, and one at each pole, generally broader, but much fainter than the others. I have never perceived much change in the form or position of the belts during the same season, but in successive years a slight degree of change has been perceptible, some of the belts having either disappeared, or turned much fainter than they were before, or shifted somewhat their relative positions; but I have never seen Jupiter without at least two or three belts. Some of the largest of these belts, being at least the one-eighth part of the diameter of the planet in breadth, must occupy a space at least 11,000 miles broad and 278,000 miles in circumference; for they run along the whole circumference of the planet, and appear of the same shape during every period of its rotation. It is probable that the smallest belts we can distinctly perceive by our telescopes are not much less than a thousand miles in breadth.

What these belts really are has been a subject of speculation and conjecture among astronomers, but it is difficult to arrive at any definite conclusion. By some they have been regarded as immense strata of clouds in the atmosphere of Jupiter; while others imagine that they are the marks of great physical changes which are continually agitating the surface of this planet. I am inclined to think that the dark belts are portions of the real surface of the planet, and that the brighter parts are something analogous to clouds, or other substances with which we are unacquainted, floating in its atmosphere, at a considerable elevation above its surface. That the dark belts are the body of the planet appears highly probable from this consideration, that the spot by which the rotation of Jupiter was determined has been always found in connection with one of the dark belts; and as this spot must be considered as a permanent one on the body of Jupiter, so the belt with which it is connected must be considered as a portion of the real body of the planet. It is absurd and preposterous to suppose, as some have done, that the changes on the surface of Jupiter are produced by physical convulsions, occasioned by earthquakes and inundations; for, in such a case, the globe of Jupiter would be unfit for being the peaceful abode of rational

inhabitants. What should we think of a world where 5000 miles of ocean occasionally inundated a corresponding portion of the land, or where earthquakes sometimes swallowed up continents of several thousands of miles in length and breadth? Such physical catastrophes recurring every year on such a splendid and magnificent globe as Jupiter would not only render it unfit for the habitation of any beings, but would imply a reflection on the wisdom and benevolence of the great Creator. Whatever opinions, therefore, we may adopt, respecting the phenomena of this planet, they ought to be such as are consistent with the idea of a habitable world and with the perfections of the Deity. Were the belts of Jupiter permanent and invariable, it would be comparatively easy to account for the phenomena which appear on his surface; for the dark belts might be considered as seas, and the brighter portions of his surface as land. But as these belts, whether bright or dark, are found to be variable, we must have recourse to another hypothesis for their explanation, or be content, in the meantime, to confess our ignorance. Our opinions and conjectures respecting the circumstances of other worlds are too frequently guided merely by what we know of the objects and operations which exist on our globe; and we are apt to think that the arrangements of other globes destined for the abode of intellectual beings must be similar to those of our own. We talk of physical convulsions, earthquakes, and inundations in Jupiter, and of volcanic eruptions in the sun and moon, as if these phenomena were as common in other worlds as in the earth; whereas it is not improbable that they are *peculiar* to our globe, and that they are connected with the moral, or rather *demoralized* state of its present inhabitants. There is an *infinite variety* in the system of nature; and it is highly probable that there is no world in the universe that exactly resembles another. Although Jupiter moves round the sun, and turns upon his axis by the same laws which direct the motions of our globe, yet there may be as great a difference in the arrangements connected with this planet and those of the earth, as there is between the constitution of the earth and that of a planet which revolves around the star Sirius.—Would it be altogether improbable to suppose that the globe of Jupiter is partly inclosed within a sphere of semitransparent substance, at a considerable elevation above his surface, or rather within parallel rings, like an Armillary sphere composed of such a substance, which vary their position, and sometimes surround one part of his globe and sometimes another? These rings, of whatever substance they might be composed, might serve to reflect the rays of the sun so as to produce an addition of light and heat, and, at the same time, by exhibiting a variety of colors and motions, to diversify and adorn the firmament of this planet. Almost any supposition is preferable to the idea of a continued scene of physical convulsions.—The idea now thrown out is not more extravagant than that of a planet nearly as large as Jupiter being surrounded with two concentric rings. Had we not discovered the rings of Saturn, we should never have formed the idea of a world environed with such an appendage. As a corroboration of the idea that the bright stripes which appear on this planet surround its body at a considerable elevation, it has been observed by Sir John Herschel, “that the dark belts do not come up in all their strength to the edge of the disc, but fade away gradually before they reach it;” an almost decisive proof that the bright belts inclose the

dark ones, or, in other words, the body of the planet; and that they are elevated above the dark globe of Jupiter, in all probability, not less than a thousand miles.

Whatever opinion we may form as to the constitution of this planet, the phenomena it presents afford a vast field for investigation and reflection. If it be a fact, as has been asserted by credible observers, that two belts have gradually disappeared during the time of an observation, and that, at another time, a new belt has been formed in an hour or two, agents far more powerful than any with which we are acquainted must have been in operation to produce such an effect, and changes more extensive than any which take place in our terrestrial sphere must have happened in the regions connected with Jupiter; for some of the belts of this planet are from five to ten thousand miles in breadth; and if those alluded to extended quite across the disc of the planet, they must have been more than one hundred and thirty thousand miles in length. Yet such a change may have taken place, not only without convulsions, causing terror and confusion, but to the admiration and joy of the inhabitants of that globe, as opening up a new and striking scene in the canopy of heaven; for if we suppose such bright belts or circles as we have imagined rapidly to shift their position in the canopy above, such a grand effect might in a short time be produced.

Beside the belts, spots of different kinds, some of them brighter and some darker than the belts, have been occasionally seen. The spot by which Jupiter's rotation was determined is the largest and of the longest continuance of any hitherto observed. Its diameter is one-tenth of the diameter of Jupiter, and it is situated in the northern part of the southern belt. Its center, when nearest that of the planet, is distant from the center of Jupiter about one-third of the semidiameter of the planet. This spot was first perceived by Hook and Cassini in the years 1664, 1665, and 1666. It appeared and vanished eight times between the years 1665 and 1708. From 1708 until 1713 it was invisible; the longest time of its continuing visible was three years, and the longest period of its disappearing was from 1708 to 1713. It has evidently some connection with the southern belts; for it has never been seen when that disappeared, though that belt has often been visible without the spot. Beside this ancient spot, as it is called, Cassini, in the year 1699, saw one of less stability, which did not continue of the same shape and dimensions, but broke into several small ones, of which the revolution was but 9 hours, 51 minutes; and two other spots which revolved in 9 hours, 52½ minutes. The large spot described above, being about the one-tenth of the diameter of Jupiter, must have been more than 8000 miles in extent, and, consequently, larger than the diameter of the earth. When Cassini had assured himself of the period of rotation from the motion of this spot, he made a report of his observations to the Royal Academy of Sciences, and calculated the precise moment when the spot would appear on the eastern limb of the planet, on a future day; on which the academy sent a deputation of M. Buet, M. Mariotte, and others, to be present at the observation; and when they came to the royal observatory, they saw the spot in the position predicted, and traced its motion for an hour or two, until the heavens began to be overcast with clouds. All the observations which have been made upon this spot and others, and its successive appearance and disappearance, perfectly agree

with the idea of bright belts inclosing the globe of Jupiter at a distance from the surface, and varying their aspect and motions at different periods of time. And although some readers may consider it as a trifling matter to dwell with such particularity on a spot in Jupiter, yet that spot, however insignificant it may appear through our telescopes, may be more spacious and important in the system of nature than all the continents and islands of our globe, and may form a greater portion of the divine government than all the kingdoms of the earth.

There is a peculiar splendor in the appearance of Jupiter, both through the telescope and to the naked eye, considering his great distance from the sun and from the earth. The planet Mars appears comparatively dull and obscure, even when nearest the earth, when it is only fifty millions of miles distant; while the planet Jupiter, which is 350 millions of miles farther from the earth and from the source of light, presents a brilliancy of aspect far superior. This circumstance seems to indicate that there is some apparatus connected with the globe of Jupiter calculated to reflect the light of the sun in a peculiar manner, both on the surface of the planet itself, on its moons, and toward other planets. Such an apparatus is not only consistent with the supposition thrown out above, but tends to corroborate it; and however strange we may consider the idea of brilliant belts surrounding a planet, yet as *variety* is stamped on all the works of the Creator, and as no world is precisely like another, the dissimilarity of such an appendage to what we know of our own or of other globes ought to be no argument against its existence. If we wish to know more of the phenomena of this planet than what we have hitherto ascertained, we must endeavor to improve our telescopes, and to increase, indefinitely, the number of observers. Were an immense number of intelligent observers distributed over different parts of the earth, and provided with the best telescopes; were they to mark with care and minuteness the phenomena to which we have adverted; were they to delineate, in a series of drawings, the various aspects of this planet during two or three periodical revolutions, marking the periods of the different changes, and the positions of the planet with respect to the earth and the sun, and noting at the same time the positions of the satellites when any change in the belts took place, we might possibly ascertain something more of the nature of the belts, whether dark or bright, of the periods of their changes, and whether these changes be influenced by the attractive power of the satellites. For if any appendage is connected with Jupiter composed of a substance of small density, it is reasonable to believe that its positions and movements would be affected at certain times by the positions of the satellites, especially when they all happened to be situated on the same side of Jupiter.

*Seasons, Proportion of Light, &c., in Jupiter.*—The axis of this planet being nearly perpendicular to the plane of its motion, there can be no variety of seasons similar to what we experience. The inclination of its axis, however, is stated by some astronomers, to be 86 degrees, 54½ minutes; or 3 degrees, 5½ minutes from the perpendicular. This inclination will cause a slight variety of seasons at different periods of the planet's annual revolution, but not nearly to the same extent as in Mars or the earth. If the axis of Jupiter were as much inclined to his ecliptic as the axis of the earth, his polar regions would remain in darkness

for nearly six years without intermission, just as the places around our north and south poles are deprived of the light of the sun for one-half of the year. There will be nearly equal day and night in every part of the surface of this planet; but to the places near the equator the sun will appear to rise to a high elevation above the horizon, and to move through the heavens with great rapidity, while near the polar regions he will appear to move comparatively slow, and to describe only a small semicircle above the horizon. We are not to imagine, however, that "everlasting winter" prevails around the poles of this planet, as some have asserted, because the sun never rises high above those regions, and the solar rays fall obliquely upon them; for there may be arrangements and compensations, of which we are ignorant, to produce nearly as great a degree of light and heat in the polar as in the equatorial regions; and perhaps the bright belts to which we have adverted may be so arranged as to contribute to this effect. Nor are we to imagine that there is no *variety of scenery* in Jupiter because there are no seasons similar to ours. For every degree of latitude from the equator to the poles will produce a diversity of aspect; and the variation of the belts, whatever may be their arrangement, and of what substances soever they may consist, will produce a diversity of scenery in the firmament of Jupiter far greater, and, perhaps, far more magnificent and transporting than anything we contemplate in our terrestrial globe.

The *intensity of the solar light* on the surface of Jupiter is twenty-seven times less than on the earth. The mean apparent diameter of the sun, as seen from the earth, is thirty-two minutes, three seconds; but the solar diameter, as seen from Jupiter, is only six minutes, nine seconds, which is less than one-fifth as great as the sun appears to us. The square of 6' 9", or 369", is 136,161, and the square of 32' 3" is 369,729, which, divided by 136,161, produces a quotient of 27 1-6, which shows that the surface of the sun, as seen from Jupiter, is more than twenty-seven times less than he appears to us; and as the intensity of light decreases in proportion to the square of the distance, there will be twenty-seven times less light on this planet than on the earth. But if the intensity of the light be increased by reflection from any substances connected with this planet, or if the inhabitants have the pupils of their eyes much larger than ours, all the objects around them may appear with even greater splendor than on the earth. The following figures will show to the eye the proportional size of the sun as seen from Jupiter and from the earth. The small circle shows the comparative bulk of the solar orb as seen from Jupiter, and the larger circle its bulk as viewed from the earth.

Fig. 55.

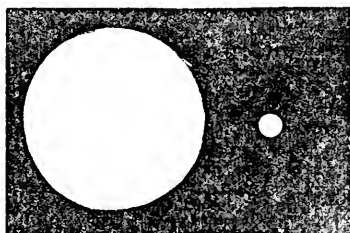

Nothing particular has been ascertained respecting an *atmosphere* surrounding this planet.— Though it is probable that it has an appendage

answering the purpose of an atmosphere, yet it may be very different in its nature and properties from that which surrounds the earth. And if the planet be surrounded with bright belts, as we have supposed, or if the bright parts of its surface are to be considered as something analogous to clouds suspended in a body of air, it is evident that the denser parts of its atmosphere never can be perceived by us, and that no dimness or obscurity is to be expected when a fixed star approaches its disc. Hence M. Schroeter, when he had a very clear and distinct view of the spots and belts when Jupiter suffered an occultation by the moon on the 7th of April, 1792, could perceive nothing throughout the whole observation indicative of a refractive medium near the margin of the planet.

Jupiter is remarkable on account of his *spheroidal figure*. This figure is obvious to the eye when viewing the planet with a high magnifying power. Nor is this an optical illusion; for both diameters have been accurately measured by the micrometer; and the equatorial diameter is found to be in proportion to the polar nearly as fourteen to thirteen, so that the equatorial is more than 6300 miles longer than the polar diameter. This oblate figure is ascribed to the swiftness of Jupiter's rotation, which produces a centrifugal force, which has a tendency to make the equatorial parts more protuberant than the polar. From calculations formed on the principles of physical astronomy, it is found that the proportion above stated is really the degree of oblateness which corresponds, on those principles, to the dimensions of this planet and the time of its rotation; so that theory perfectly harmonizes with observation.

The *density* of this planet compared with that of water is as 1 1-24 to 1; that is, it is a small fractional part denser than water. Its *mass*, compared with that of the sun is as 1 to 1067; compared with that of the earth, as 312 to 1; that is, Jupiter could weigh 312 globes of the same size and density as the earth. The *eccentricity* of its orbit is 23,810,000 miles; and the *inclination* of the orbit to the ecliptic is about one degree, nineteen minutes. Its mean *apparent diameter* is thirty-eight seconds, and its greatest diameter, when in opposition to the sun, forty-seven and a half seconds. Its mean arc of retrogradation is nine degrees, fifty-four minutes, and its mean duration about 121 days. This retrogradation, or moving contrary to the order of the signs, commences or finishes when the planet is not more than 115 degrees from the sun. The following figure exhibits a view of Jupiter and his satellites as seen through a good telescope. \*

Fig. 56.

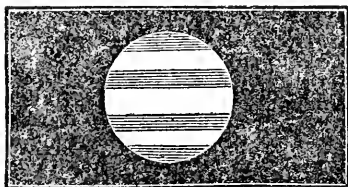

VII. ON THE PLANET SATURN.

The planet Saturn may be considered in almost every respect as the most magnificent and interesting body within the limits of the planetary system. Viewed in connection with its satellites and rings, it comprehends a greater quantity of surface than even the globe of Jupiter; and its

majestic *rings* constitute the most singular and astonishing phenomena that have yet been discovered within the limits of our system.

Its distance from the sun is 906 millions of miles, which is nearly twice the distance of Jupiter; and the circumference of its orbit is 5,695,000,000 of miles; to move round which a cannon ball would require more than 1300 years, although it were moving 500 miles every hour. But a steam-carriage, moving at the rate of twenty miles an hour, would require above 32,500 years to complete the same round. When nearest the earth, Saturn is 811 millions of miles distant, an interval which could not be traversed by a carriage, at the rate now stated, in less than 4629 years; and even a cannon ball, moving with the velocity above mentioned, would require 184 years. So that, although man were divested of the gravitating power, and capable of supporting himself amid the ethereal regions, and though he were invested with a power of rapid motion superior to any movement we perceive on earth, before he could reach the middle orbit of the planetary system, or one-fourth of its diameter, it would require a space of time far more than is yet allotted to mortal existence, and, therefore, all hope of personally exploring the celestial regions is completely annihilated, so long as we are invested with our present corporeal vehicles, and are connected with this terrestrial abode.

This planet revolves round the sun in the space of about 29½ years, or in 10,758 days, 23 hours, 16 minutes, 34 seconds, which is its *sidereal revolution*, or the time it takes in moving from a certain fixed star to the same star again. Through the whole of its circuit it moves at the rate of 22,000 miles every hour. The period of its rotation was for a long time unknown. About a century ago, it was conjectured by some astronomers that it was accomplished in about ten or eleven hours. It was not, however, until Sir W. Herschel applied his powerful telescopes to Saturn that its rotation was accurately determined. By certain dark spots which he perceived on its disc, and by their change of position, he ascertained that the diurnal rotation is performed in ten hours, sixteen minutes, and nineteen seconds.\* It is remarkable that La Place, from physical considerations, had calculated the rotation of Saturn to be nearly the same as above stated, before Herschel had determined it by direct observation. The rotation is performed on an axis perpendicular to the plane of the ring. The circumference of Saturn being 248,000 miles, the parts about the equator will move at the rate of 24,000 miles an hour. Its year will consist of 25,150 days, or periods of its diurnal rotation.

*Proportion of Light on Saturn.*—This planet being about 9½ times farther from the Sun than the earth, it will receive only the *one-ninetieth* of the light which we receive; for the square of 9½ is equal to 90¼. This quantity of light, however, is equal to the light which would be reflected from a thousand full moons such as ours; and there can be little doubt that the beings that reside in this planet have their organs of vision so constructed as to be perfectly adapted to the quantity of light they receive; and, by such an adaptation, all the objects around them may appear as splendidly enlightened, and their colors as vivid as they do on the globe on which we live. The apparent diameter of the sun, as seen from Saturn, is three minutes, twenty-two seconds; but his

\* Sir John Herschel states the period of rotation to be ten hours, twenty-nine minutes, seventeen seconds.

mean apparent diameter, as seen from the earth, is equal to thirty-two minutes, three seconds. This proportion of size in which the sun appears from the earth and from Saturn is represented in the following figure, in which the small circle represents the size of the sun as seen from Saturn.

Fig. 57.

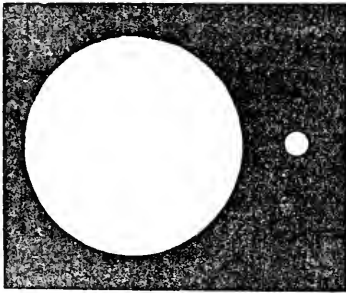

*Discoveries by the Telescope on the Body of Saturn.*—The great distance of this planet from the earth prevents us from observing its surface so minutely as that of Jupiter. Certain dusky spots, however, have of late years been occasionally seen on its surface, when very powerful telescopes were applied, and by the motion of these its diurnal rotation was determined. Belts somewhat similar to those of Jupiter have likewise been seen. Huygens, more than 150 years ago, states that he had perceived five belts on Saturn which were nearly parallel to the equator. Sir W. Herschel, in his numerous observations, also observed several belts, which in general, were parallel with the ring. On the 11th of November, 1798, immediately south of the shadow of the ring upon Saturn, he perceived a bright, uniform, and broad belt, and close to it a broad or darker belt, divided by two narrow white streaks, so that he saw five belts, three of which were dark and two bright. The dark belt had a yellow tinge. These belts cover a larger zone of the disc of the planet than the belts of Jupiter occupy upon his surface. With a magnifying power of 200 times I have sometimes seen one darkish belt on the body of Saturn; but it was much fainter than those of Jupiter. It does not appear that these belts vary or shift their positions, as the belts of Jupiter are found to do; the dark ones are much fainter than those of Jupiter, and, therefore, it is most probable that they are permanent portions of the globe of Saturn, which indicate a diversity of surface and configuration either of land or water, or of some other substances with which we are unacquainted. When this planet is viewed with a good telescope, it appears, like Jupiter, to be of a spheroidal figure, or somewhat approaching to it. The proportion of its polar to its equatorial diameter is as 32 to 35, or nearly as 11 to 12; so that the polar diameter is more than 6,700 miles shorter than the equatorial, which is a greater difference than that of the two diameters of Jupiter. Saturn was generally considered, until lately, as a regular spheroid; but on the 12th of April, 1805, Sir W. Herschel was struck with a very singular appearance when viewing the planet. "The flattening of the poles did not seem to begin until near a very high latitude, so that the real figure of the planet resembled a square, or rather a parallelogram, with the four corners rounded off deeply, but not so much as to bring it to a spheroid." It is probable that the action of the ring or its attractive power is the cause of

the great protuberance which is found about the equatorial regions of Saturn.

*Magnitude and Extent of Surface on Saturn.*—This planet is about 79,000 miles in diameter, and nearly a thousand times larger than the earth. Its surface contains more than 19,600,000,000 of square miles, and, consequently, at the rate of 280 inhabitants to a square mile, it would contain a population of 5,488,000,000,000, or about five billions and a half, which is six thousand eight hundred and sixty times the present number of inhabitants on our globe; so that this globe, which appears only like a dim streak on our nocturnal sky, may be considered as equal to six thousand worlds like ours; and since such a noble apparatus of rings and moons is provided for the accommodation and contemplation of intelligent beings, we cannot doubt that it is replenished with ten thousand times ten thousands of sensitive and rational inhabitants; and that the scenes and transactions connected with that distant world may far surpass in grandeur whatever has occurred on the theater of our globe.

*Density of Saturn.*—The density of Saturn, compared with that of the earth, is nearly as one to nine; compared with that of water, it is less than one-half; so that the mean density of this planet cannot be much more than the density of cork; and, consequently, the globe of Saturn, were it placed in an immense ocean, would swim on the surface as a piece of cork or light wood swims in a basin of water. There is none of the planets, so far as we know, whose density is so small as that of Saturn, or less than the density of water. We are not to imagine, however, that the materials which compose the surface of Saturn are as light as cork, or similar substances; for anything we know to the contrary, they may be as dense as the rocks and mold which compose the crust of our globe. We have only to suppose that the globe of Saturn is hollow, or merely filled with some elastic fluid, and that the solid parts of its exterior crust form a shell of a hundred or two hundred miles in thickness. It is true, indeed, that the density of our globe increases from its surface downward, perhaps even to the center. But we have no reason to suppose that this is the case with all the other planets; on the contrary, it is most probable that it is exactly the reverse in the case of Saturn; for if the materials which compose that planet were to increase in density toward the center, the substances on its surface would have little more density or solidity than that of a cloud suspended in the atmosphere. And we know that, in all the works of the Creator, *variety* is one grand characteristic of his plans, even where the same general objects are intended to be accomplished, and the same *general* laws are in operation.

From want of correct views on this subject, several foolish and erroneous notions have been entertained and circulated. In a late number of a popular and extensively circulated journal, when treating of "Planetary Arrangements," it is stated, that "while on Mercury a native of earth would scarcely be able to drag one foot after another for the strong power pulling him to the ground, he could, on the planet Saturn, leap sixty feet high as easily as he could here leap a yard." Now, both these positions are quite erroneous; for although the density of Mercury is about double the density of the earth, and nearly that of lead, yet the bulk of the two planets is very different, the diameter of the earth being nearly 8000 miles, while that of Mercury is only 3200, and the force with which a body placed on their surfaces gravitates to them is in proportion

to their masses divided by the squares of their diameters. If Mercury were as large as the earth, an inhabitant of our globe placed on the surface of that planet would feel himself "pulled to the ground" as if he were placed on a similar ball of lead, and his weight, of course, would be increased; but, as matters now stand, the gravitation on Mercury is only a small fraction greater than on the surface of the earth; so that, in this respect, "a native of the earth," and particularly an inhabitant of Greenland, might walk with nearly as much ease on the planet Mercury as under our equator. The same considerations show the absurdity of what is stated in relation to Saturn; for that planet is ten times the diameter of the earth; and though its density is nearly as small as that of cork, yet its immense bulk renders the force of gravity at its surface somewhat greater than even on the earth, and almost as great as on the surface of Mercury. A body which weighs one pound on the surface of the earth would weigh one pound and four drachms if removed to the surface of Saturn; so that a person, instead of being able to "leap sixty feet high" from the surface of this planet, would be unable to leap quite so high as he can do on the earth. In short, there is not a planet in the solar system, with the exception of Jupiter, on which an inhabitant of the earth might not move about as easily, in respect to gravitating power, as he does on the terraqueous globe; and even on Jupiter, he would experience little more than double the weight he now feels. On some of the other planets, such as Mars and Juno, he would feel somewhat lighter than he now does, but not nearly so much as would enable him to leap to such a height as above stated. On the same principle, which is taken for granted in the above quotation, we might suppose that a person would feel much lighter were he placed on the surface of the sun, because the density of that luminary is little more than the density of water; whereas, in consequence of his immense size, the gravitating power would be *twenty-seven* times greater than at the surface of our globe. For, according to the calculations of La Place, a body which, at the earth's equator, weighs one pound, if transported to the surface of the sun, would weigh about twenty-seven and a half pounds; from which it follows, that there a heavy body would descend about four hundred and twenty-five feet in the first second of time; consequently, were a man who weighs two hundred pounds to be placed on the sun, he would be pressed down to its surface with a force equal to five thousand five hundred pounds, or nearly two tons and a half, which would fix him to the surface without power of motion. So that whatever beings may inhabit that globe, it is not fitted for the residence of man in his present state of organization.

The *eccentricity* of Saturn's orbit is 49,000,000 of miles, which is about the 1-37th part of the diameter of the orbit. Its inclination to the ecliptic is  $2^{\circ} 29\frac{1}{2}'$ . Its apparent diameter, as seen from the earth, is seventeen minutes, six seconds; and its mean daily motion, two minutes of a degree.

#### VIII. ON THE RINGS OF SATURN.

Beside the appearance above described, this planet is encircled with a double ring, one of the most astonishing phenomena which have yet been discovered in the heavens, and which, therefore, requires a separate and particular description.

The first individual who perceived a glimpse of Saturn's ring was Galileo, soon after the invention of the telescope. He thought he saw that planet appear like two smaller globes on each side of a larger globe; or, as he expressed it, that "Saturn was in the shape of an olive." In the year 1610, he published his discovery in a Latin sentence, the meaning of which was, that he had seen Saturn appear *with three bodies*. After viewing Saturn in this form for two years, he was surprised to see him become quite round without his adjoining globes, and to remain in this state for some time, and, after a considerable period, to appear again in his triple form as before. This deception was owing to the want of magnifying power in the telescope used by Galileo; for the first telescope constructed by this astronomer magnified the diameters of objects only three times; his second improved telescope magnified only eight times; and the best telescope which, at that time, he found himself capable of constructing, magnified little more than *thirty times*; and with this telescope he made most of his discoveries. But a telescope of this power is not sufficient to show the opening or dark space between the ring and Saturn on each side of the planet; and at the time when it appeared divested of its two appendages, the thin and dark edge of the ring must have been in a line between his eye and the body of Saturn, which phenomenon happens once every fifteen years. About forty years after this period, the celebrated Huygens greatly improved the art of grinding object glasses; and with a telescope of his own construction, twelve feet long, and afterward with another of twenty-three feet, which magnified objects one hundred times, he discovered the true shape of Saturn's ring, and in 1659 he published his "*Systema Saturnium*," in which he describes and delineates all its appearances.

It was suspected by astronomers more than a century ago, that the ring of Saturn was double, or divided into two concentric rings. Cassini supposed it probable that this was the case. Mr. Pound, in the account of his observations on Saturn in 1723, by means of Hadley's new reflecting telescope, states that with this instrument he could plainly perceive "*the black list in Saturn's ring*," and gives an engraving of the planet and ring with this dark stripe distinctly marked, as in the modern views of Saturn.\* Mr. Hadley likewise states† that, in the year 1722, with the same telescope, he observed the dark line on the ring of Saturn parallel to its circumference, which was chiefly visible on the anse, or extremities of the elliptic figure in which the ring appears, but that he was several times able to trace it quite round; particularly in May, 1722, he could discern it without the northern limb of Saturn, in that part of the ring that appeared beyond the globe of the planet, and could perceive that the globe of Saturn reflects less light than the inner part of the ring. It was not, however, until Sir W. Herschel began to make observations on this planet with his powerful telescopes, that Saturn was recognized as being invested with two concentric rings. The following cut (Fig. 58) exhibits a view of Saturn and his rings, nearly in their respective proportions, as they would appear were they placed perpendicular to our line of sight; but, on account of the oblique angle

\* See "*Philosophical Transactions*," No. 378, for July, 1723; and Reid and Gray's Abridgment, Vol. vi, p. 153.

† "*Philosophical Transactions*," No. 378; or Abridgment, Vol. vi, p. 154.

they generally form to our line of vision, we never see them through the telescope in this position.

Fig. 58.

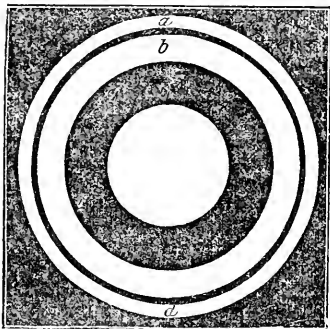

The following are the dimensions of the rings, as determined by the observations of Sir W. Herschel, which are here expressed in the nearest round numbers. Outside diameter of the exterior ring, *a* *d*, 204,800 miles, which is nearly twenty-six times the diameter of the earth. Inside diameter of this ring, 190,200 miles; breadth of the dark space between the two rings, 2839 miles, which is 700 miles more than the diameter of our moon, so that a body as large as the moon would have room to move between the rings. Outside diameter of the interior ring, *b*, 184,400, and the inside diameter, 146,300 miles. Breadth of the exterior ring, 7200 miles; breadth of the interior, 20,000 miles, or  $2\frac{1}{2}$  times the diameter of the earth; so that the interior ring is nearly three times broader than the exterior. The thickness of the rings has not yet been accurately determined. Sir John Herschel supposes that it does not exceed a hundred miles. "So very thin is the ring," says Sir John, "that it is quite invisible, when its edge is directly turned to the earth, to any but telescopes of extraordinary power." On the 19th of April, 1833, "the disappearance of the rings was complete when observed with a reflector eighteen inches in aperture and twenty feet in focal length.\* The breadth of the two rings, including the dark space between them, is very nearly equal to the dark space which intervenes between the globe of Saturn and the inside of the interior ring. It appears to have been lately ascertained that this double ring is not exactly circular, but eccentric. This seems to have been first observed by M. Schwab, of Dessau, in 1828. He informed M. Harding of it, who thought he saw the same thing; M. Harding informed Professor Schumacher, who applied to M. Struve to settle the question by means of the superb micrometer attached to his great telescope. M. Struve measured the distance between the ring and the body of the planet on five different days, and ascertained that *Saturn's ring is really eccentric*, and, consequently, that the center of the planet does not coincide with the center of the ring; but that the center of gravity of the rings oscillates round that of the body of Saturn, describing a very minute orbit. This is considered as of the utmost importance to the *stability* of the system of the rings, in preventing them from

being shifted from their equilibrium by any external force, such as the attraction of the satellites, which might endanger their falling upon the planet. That this double ring really consists of two concentric rings, was demonstrated, says Professor Robison, "by a star having been seen through the interval between them."

This double ring is now found to have a swift rotation round Saturn in its own plane, which it accomplishes in about ten hours and a half. This is very nearly the periodic time which a satellite would take in revolving at the same distance from the center of Saturn. This rotation was detected by observing that some portions of the ring were a little less bright than others. Sir W. Herschel, when examining the plane of the ring with a powerful telescope, perceived near the extremity of its arms or *ansæ* several lucid or protuberant points, which seemed to adhere to the ring. At first he imagined them to be satellites, but afterward found, upon careful examination, that none of the satellites could exhibit such an appearance, and therefore concluded that these points adhered to the ring, and that the variation in their position arose from a rotation of the ring round its axis in the period above stated. The circumference of the exterior ring being 643,650 miles, every point of its outer surface moves with a velocity of more than a thousand miles every minute, or seventeen miles during one beat of the clock. It is highly probable that this rapid rotation of the ring is one of the principal causes, under the arrangements of the Creator, of *sustaining* the ring, and preventing it from collapsing and falling down upon the planet. This double ring is evidently a *solid* compact substance, and not a mere cloud or shining fluid; for it casts a deep shadow upon different regions of the planet, which is plainly perceived by good telescopes. Beside, were it not a solid arch, its centrifugal force, caused by its rapid rotation, would soon dissipate all its parts, and scatter them in the surrounding spaces. It is not yet ascertained whether both the rings have the same period of rotation. This magnificent appendage to the globe of Saturn is about 30,000 miles distant from the surface of the planet, so that four globes nearly as large as the earth could be interposed between them; it keeps always the same position with respect to the planet; is incessantly moving around it; and is carried along with the planet in its revolution round the sun.

The surface of the double ring does not seem to be exactly plane. One of the *ansæ*\* sometimes disappears and presents its dark edge, while the other *ansa* continues to appear, and exhibits a part of its plane surface. On the 9th of October, 1714, the *ansæ* appeared twice as short as usual, and the eastern one much longer than the western. On the first of the same month, the largest *ansa* was on the east side; on the 12th, the largest *ansa* was on the west side of Saturn's disc; which led the observers, even at that period, to conclude that the ring had a rotation round the planet. On the 11th of January, 1774, M. Messier observed both the *ansæ* completely detached from the planet,

\* The parts of the ring about the ends of the longest axis, reaching beyond the disc of the planet, are called the *ansæ*. *Ansa* signifies a *handle*, which name was given when telescopes were so imperfect as to represent Saturn as a globe with two small knobs on each side. The same name is still continued, though it is somewhat improper, now that the true shape of this appendage is known. Still the general appearance of Saturn is somewhat like a globe, with an *ansa* or handle on each side.

† *Memoirs of the Royal Academy of Sciences for 1715.*

\* Sir John Herschel states the dimensions of these rings on a somewhat lower scale than what his father determined. He says that they were calculated from Professor Struve's micrometrical measures; but admits that some of the dimensions he states are perhaps too small.



and the eastern one larger than the other. In 1774, Sir W. Herschel likewise observed Saturn with a single ansæ. From these observations, it has been concluded that there are irregularities on the surface of the ring, analogous, perhaps, to mountains and vales of vast extent; and that the occasional disappearance of the ansæ may possibly arise from a curvature in its surface. Sir W. Herschel was of opinion that the *edge* of the exterior ring is not flat, but of a spherical, or rather spheroidal form.

*Dimensions of Saturn's Rings.*—It is difficult for the mind to form an adequate conception of the magnitude, the mechanism, and the magnificence of these wonderful rings, which form one of the most astonishing objects that the universe displays. In order to appreciate, in some measure, the *immense size* of these rings, it may be proper to attend to the following statements: Suppose a person to travel round the outer edge of the exterior ring, and to continue his journey without intermission at the rate of twenty-five miles every day, it would require more than *seventy years* before he could finish his tour round this immense celestial arch. The interior boundary of the *inner ring* incloses a space which would be sufficient to contain within it three hundred and forty globes as large as the earth; and the *outer ring* could inclose within its inner circumference five hundred and seventy-five globes of the same magnitude, supposing every portion of the inclosed area to be filled. This outer ring would likewise inclose a globe containing 2,829,500,622,048,315 or more than two thousand eight hundred *billions* of cubical miles, which globe would be equal to more than *ten thousand eight hundred globes* of the size of the earth. In regard to the *quantity of surface* contained in these rings, the one side of the outer ring contains an area of 4,529,401,800, or more than four thousand five hundred millions of square miles. The one side of the inner ring contains 9,95,780,818, or nearly ten thousand millions of square miles. The two rings, therefore, contain on one side above fourteen thousand four hundred millions of square miles; and as the other sides of the rings contain the same extent of surface, the whole area comprehended in these rings will amount to 28,850,365,236, or more than twenty-eight thousand eight hundred millions of square miles. This quantity of surface is equal to 146 times the number of square miles in the terraqueous globe, and is more than 588 times the area of all the habitable portions of the earth. Were we to suppose these rings inhabited (which is not at all improbable) they could accommodate a population, according to the rate formerly stated, of 8,078,102,266,080, or more than *eight billions*, which is equal to more than *ten thousand times* the present population of our globe; so that these rings, in reference to the space they contain, may be considered, in one point of view, as equal to ten thousand worlds.

Were we to take into consideration the *thickness* of the rings, we should find a very considerable addition to the area above stated. Supposing, according to Sir J. Herschel's estimate, that they are only one hundred miles thick, the area of the exterior circumference of the edge of the *outer ring* will be 64,365,700 miles; and that of the interior edge, 59,777,100. The exterior edge of the *inner ring* will contain an area of 57,954,200 square miles, and the interior edge 45,980,000; in all 228,077,000 square miles, which is thirty-one millions of square miles more than the whole area of our globe.

These rings, therefore, exhibit a striking idea

of the *power* of the Creator, and of the grandeur and magnificence of his plans and operations. They likewise display the depths of his *wisdom* and intelligence; for they are so adjusted, both in respect to their position around the body of the planet and to the degree of motion impressed upon them, as to prevent both their falling in on the planet and their flying off from it through the distant regions of space. We have already stated that the rings are not exactly concentric with the body of the planet. Now, it is demonstrable, from physical considerations, that were they mathematically perfect in their circular form, and exactly concentric with the planet, "they would form a system in a state of *unstable equilibrium*, which the slightest external power," such as the attraction of the satellites, "might completely subvert, by precipitating them unbroken on the surface of the planet." For physical laws must be considered as operating in the system of Saturn as well as in the earth and moon, and the other planets; and every minute circumstance must be adjusted so as to correspond with these laws. "The observed oscillation," says Sir J. Herschel, "of the centers of the rings about that of the planet is, in itself, the evidence of a perpetual contest between conservative and destructive powers, both extremely feeble, but so antagonizing one another as to prevent the latter from ever acquiring an uncontrollable ascendancy and rushing to a catastrophe." "The smallest difference of velocity between the body and rings must infallibly precipitate the latter on the former, never more to separate: consequently, either their motions in their common orbit around the sun must have been adjusted to each other by an external power with the minutest precision, or the rings must have been formed about the planet while subject to their common orbital motion and under the full free influence of all the acting forces." Here, then, we have an evident proof of the consummate wisdom of the almighty Contriver in so nicely adjusting everything in respect to number, weight, position and motion, as to preserve in undeviating stability and permanency this wonderful system of Saturn; and we have palpable evidence that everything conducive to this end has been accomplished, from the fact that no sensible deviation has been observed in this system for more than 220 years, or since the ring was discovered; nor, in all probability, has there ever been any change or catastrophe in this respect since the planet was first created and launched into the depths of space.

*Appearance of the Rings from the body of Saturn.*—These rings will appear in the firmament of Saturn like large luminous arches or semicircles of light, stretching across the heavens from the eastern to the western horizon, occupying the one-fourth or one-fifth part of the visible sky.—As they appear more brilliant than the body of the planet, it is probable that they are composed of substances fitted for reflecting the solar light with peculiar splendor, and therefore, will present a most magnificent and brilliant aspect in the firmament of Saturn. Their appearance will be different in different regions of the planet. At a little distance from the equator they will be seen nearly as complete semicircles, stretching along the whole celestial hemisphere, and appearing in their greatest splendor. In the day-time they will present a dim appearance, like a cloud or like our moon when the sun is above the horizon.—After sunset their brightness will increase, as our moon increases in brilliancy as the sun disappears, and the shadow of the globe of Saturn will



be seen on their eastern boundary directly opposite to the sun. This shadow will appear to move gradually along the rings until midnight, when it will be seen near the zenith, or the highest point of these celestial arches. After midnight it will appear to decline to the western horizon, where it will be seen near the time of the rising of the sun. After sunrise the brightness decays, and it appears like a cloudy arch throughout the day. The following circumstances will add to the interest of this astonishing spectacle: 1. The *rapid motion* of the rings, which will appear to move from the eastern horizon to the zenith in two hours and a half. 2. The *diversity of surface* which the rings will exhibit; for if we can trace inequalities upon these rings by the telescope at the distance of more than 800,000,000 of miles, much more must the inhabitants of Saturn perceive all the variety with which they are adorned when they are placed so near them as the one-eighth part of the distance of our moon. Every two or three minutes, therefore, a new portion of the scenery of the rings will make its appearance in the horizon with all their diversified objects; and if these rings be inhabited, the various scenes and operations connected with their population might be distinguished from the surface of Saturn with such eyes as ours, aided by our most powerful telescopes. 3. The motion of the shadow of the globe of Saturn in a direction contrary to the motion of the rings, which shadow will occupy a space of many thousand miles upon the rings, will form another variety of scenery in the firmament. 4. If the two rings revolve around the planet in different periods of time, the appearance in the celestial vault will be still more diversified; then one scene will be seen rising on the upper, and another and a different scene rising on the lower ring; and, through the opening between the rings, the stars, the planets, and one or two of the satellites may sometimes appear.

Near the polar regions of the planet only a comparatively small portion of the rings will appear above the horizon, dividing the celestial hemisphere into two unequal parts, and presenting the same general appearance now described, but upon a smaller scale. Toward the polar points the rings will, in all probability, be quite invisible. During the space of fourteen years and nine months, which is half the year of this planet, the sun shines on the one side of these rings without interruption, and during the same period he shines on the other side. During nearly fifteen years, therefore, the inhabitants on one side of the equator will be enlightened by the sun in the day-time and the rings by night, while those on the other hemisphere, who live under the dark side of the ring, suffer a solar eclipse of fifteen years' continuance, during which they never see the sun.— At the time when the sun ceases to shine on one side of the ring, and is about to shine on the other, the rings will be invisible for a few days or weeks to all the inhabitants of Saturn.

At first view we might be apt to suppose that it must be a gloomy situation for those who live under the shadow of the rings during so long a period as fifteen years; but we are not acquainted with all the *circumstances* of their situation, or the numerous beneficent contrivances which may tend to cheer them during this period, and, therefore, are not warranted to conclude that such a situation is physically uncomfortable. We know that they enjoy the light of their moons without almost any interruption; sometimes two, sometimes four, and sometimes all their seven moons are shining in their hemisphere in one bright as-

semblage. Beside, during this period is the principal opportunity they enjoy of contemplating the starry firmament, and surveying the more distant regions of the universe, in which they may enjoy a pleasure equal, if not superior, to what is felt amid the splendor of the solar rays; and it is not improbable that multitudes may resort to these darker regions for the purpose of making celestial observations; for the bright shining of the rings during the continuance of night will, in all probability, prevent the numerous objects in the starry heavens from being distinguished. The very circumstances, then, which might, at first view, convey to our minds images of gloom and horror, may be parts of a system in which are displayed the most striking evidences of beneficent contrivance and design. It must be a striking scene when the sun is of a sudden altogether intercepted, without any apparent cause, not to return for fifteen years; and, on the other hand, when, at the end of this period, his light again bursts all at once upon the astonished beholders, closing up, as it were, the prospects of the firmament, and diffusing his splendor on every surrounding object; and both events may be attended with sentiments of admiration and emotions of delight. At certain times of the year of Saturn, and in certain latitudes from his equator, the sun will be eclipsed for a short time, every day at noon, by the upper part of the exterior ring, according as he declines more or less to the opposite side; and sometimes he will be partially eclipsed by the under side of the exterior ring and the upper side of the interior, and sometimes will be seen moving along the interval which separates these rings.

The following figures are intended to convey a rude idea of the objects connected with the firmament of Saturn.

Fig. 59.

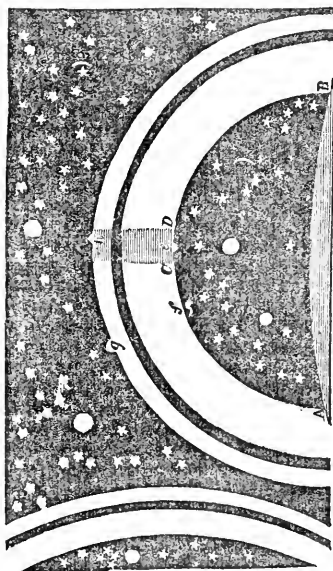

Fig. 60.

Fig. 59, represents the appearance of the rings at a little distance from the planet's equator, where they will appear nearly as complete semicircles. *A B* represents a portion of the globe of Saturn; *C D* the shadow of Saturn as it

appears upon the rings at midnight, after which it will appear to move gradually to the west until sunrise, when it will disappear below the horizon. The sun, partly eclipsed by the upper and lower edge of the rings in the day-time, is represented at *e, f, g,* and *h*. The other objects are some of the satellites in different phases, and the fixed stars, of which few will probably be seen, some of them within and some of them beyond the rings.—Fig. 69, represents the rings as they will appear from places near the polar regions of the planet, from which situations they will appear as only small segments of circles near the horizon. The nearer the pole, the smaller the circles will appear.

From the above description, it appears that there is a great *variety* in the scenery presented in the firmament of Saturn; and this scenery is different as viewed from different regions of the planet. From the regions near the equator the rings will appear to the greatest advantage and in all their splendor. From these positions the various objects connected with the rings will be most distinctly observed, as the spectators will be at the nearest distance from the inner ring, which is about thirty thousand miles. At the latitude of  $45^\circ$  they will be twenty thousand miles farther from them; they will appear at a much lower elevation above the horizon, a smaller portion of their curve will be seen, and their *breadth* will occupy a less space in the heavens. At a higher latitude a still smaller portion will be seen, until they dwindle to a small curve or speck of light in the horizon; and at the poles they will be quite invisible by the interposition of equatorial parts of the planet. Immediately under the equator the light of the rings will be scarcely visible, but the sun will occasionally illuminate the under edge of the interior ring, at *f, e, D,* and other places; which, at night, will appear like a narrow luminous arch stretching directly across the zenith from the eastern to the western horizon, and diversified with the motion of the shadow of Saturn. Beside the different appearances of the starry regions, the various aspects of the moons, some of them rising, setting, and culminating,\* some of them appearing as crescents, half moons, and full enlightened hemispheres, some entering into an eclipse, and some emerging from it, and all of them appearing to move with a rapid velocity around the sky, will greatly add to the *variety* and diversity of scenery which appears in the firmament of this planet. This diversity of aspect, which the scenery of nature presents from different regions of the planet, will, in all probability, have a tendency to promote frequent intercourses among the different tribes of its inhabitants, in order to contemplate the different scenes of nature and providence displayed throughout this spacious and magnificent globe. All these circumstances, properly considered, form of themselves a presumptive argument to prove that the sublime and exquisite contrivances connected with this planet were not intended merely to illuminate barren sands and hideous deserts, but to afford a comfortable and magnificent habitation for thousands of millions of rational inhabitants who employ their faculties in the contemplation of the wonders which surround them, and give to their Creator the glory which is due to his name.

It has often been asked as a mysterious question, "What is the *use* of the rings with which Saturn is environed?" This is a question which I conceive there is no great difficulty in answer-

\* A heavenly body is said to culminate when it comes to the meridian, or the highest point of its diurnal course.

ing. The following considerations will go a great way in determining this question: 1. They are intended to produce all the varieties of celestial and terrestrial scenery which I have described above, and doubtless other varieties with which we are unacquainted; and this circumstance of itself, although we could devise no other reason, might be sufficient to warrant the Creator to deviate from his general arrangements in respect to the other planets. For *variety* is one characteristic of his plans and operations, both in respect to the objects on our globe and to those which exist throughout the planetary system, and it is accordant with those desires for novelty and variety which are implanted in the minds of intelligent beings. 2. They are intended to give a display of the *grandeur* of the Divine Being, and of the effects of his Omnipotence. They are also intended to evince his inscrutable wisdom and intelligence in the nice adjustment of their motions and positions, so as to secure their stability and permanency in their revolutions, along with the planet, around the sun. 3. They are doubtless intended to teach us what varied scenes of sublimity and beauty the Deity has introduced or may yet introduce into various regions throughout the universe. We are acquainted with only a few particulars respecting *one* planetary system; but we have every reason to conclude that many millions of similar or analogous systems exist throughout the unlimited regions of space. In some of those systems the arrangements connected with the worlds which compose them may be as different from those of our globe and some of the other planets, as the arrangements and apparatus connected with Saturn are different from those of the planet Vesta or Mars. Around some of these worlds there may be thrown not only two concentric rings, but rings standing at right angles to each other, and inclosing and revolving round each other; yea, for aught we know, there may be an indefinite number of rings round some worlds, and variously inclined to each other, so that the planet may appear like a terrestrial globe suspended in the middle of an armillary sphere; and all those rings may be revolving within and around each other in various directions and in different periods of time, so as to produce a variety and sublimity of aspect of which we can form no adequate conception. There is nothing irrational or extravagant in these suppositions; for, had we never discovered the rings of Saturn, we could have formed no conception of such an appendage being thrown around any world, and it would have been considered in the highest degree improbable and romantic had any one broached the idea. We are therefore led to conclude, from the characteristic of *variety* impressed on the universe, that Saturn is not the only planet in creation that is surrounded with such an apparatus, and that the number and position of its rings are not the only models according to which the planetary arrangements in other systems may be constructed.

4. Beside the considerations now stated, the chief use, I presume, for which these rings were created was, that they might serve as a spacious *abode* for myriads of intelligent creatures. If we admit that the globe of Saturn was formed for the reception of rational inhabitants, there appears no reason why we should not also admit that the rings were constructed chiefly for the same purpose. These rings, as we have already seen, contain a surface of about *thirty thousand millions* of square miles; and, if all the other planets be inhabited, it is not likely that the Creator would

leave a space equal to nearly 600 times the habitable parts of our globe as a desolate waste, without any tribes of either sensitive or intelligent existence. It forms no objection to this idea that the rings are *flat*, and not globular like the planets; for the Creator can arrange any figure of a world into a suitable abode for intelligent beings; and on our globe we find myriads of animated beings fitted for every mode of existence, and in situations where we should scarcely ever have expected to see them. Beside, three or four centuries have scarcely elapsed since the earth was generally considered as a *plane* indefinitely extended; and the idea of its being a globe, inhabited on all sides, was scouted as untenable, and considered far more ridiculous than it can be now to suppose the flat rings of Saturn as serving the purpose of a habitable world. What should hinder them from serving this purpose as well as the globe of Saturn? They are *solid* arches, which is evident from their shadows and their rapid motion; they contain an ample space for an immense population; they have the power of attraction, like other material substances connected with the solar system; they are capable of being adorned with as great a diversity of surface, and as great a variety of beautiful and sublime objects, as this earth or any other of the planetary bodies; and it can make no great difference in the enjoyments of sentient and intellectual beings whether they live on a globe, a spheroid, a cylinder, or a plane surface, which the hand of Wisdom and Omnipotence has prepared for their reception; while it displays, at the same time, the variety of modes in which the Universal Parent can convey happiness to his numerous offspring. It may, perhaps, be objected to the idea of the habitability of these rings, that, while one side is enlightened during fifteen years without intermission, the other side remains in the dark during the same period. But the same thing happens to extensive regions on the globe of Saturn; and, doubtless, arrangements are made for the enjoyment of the inhabitants in both cases during this period. They enjoy in succession, and sometimes all at once, the light reflected from at least seven moons, and they behold occasionally the body of Saturn reflecting the solar rays from certain parts of its surface, and appearing like a vast luminous crescent, in different degrees of luster, suspended in the sky. (See p. 69.)

Many other views and descriptions might be given of the phenomena connected with the system of Saturn, were it not that I do not wish to exhaust the patience of the reader by dwelling too long on one subject. The circumstance of two concentric rings being thrown around a planet, however simple it may at first sight appear, involves in it an immense variety of peculiar and striking phenomena, in regard both to the inhabitants of the planet and of the rings, so that it is difficult for the mind to form a precise and definite conception of every particular. To acquire even a general view of such phenomena, it would be requisite to construct a pretty large machine, representing the system of Saturn, in all its known motions and proportions, and to make it revolve around a central light. An instrument of this kind is as necessary for illustrating the subject on which we have been descending, as an orrery or planetarium to illustrate the seasons and the planetary motions.

*Telescopic Views of Saturn and its Rings.*—As these rings present a variety of aspects as seen from different parts of the planet, so they appear to assume a different appearance at different times

when viewed through our telescopes. Sometimes the planet appears to be completely divested of its rings; sometimes they appear only like a short luminous line or streak on each side of its body; sometimes they appear like handles on each side of the planet; and at other times like a large ellipse or oval almost surrounding the body of the planet. These varied aspects of the rings are owing to the following circumstances. The rings never stand at right angles to our line of vision; otherwise we should see them as represented in Fig. 58 (p. 67). Our eye is never elevated more than thirty degrees above the plane of the rings. The *plane* of these rings preserves a position parallel to itself in every part of the planet's revolution, being constantly inclined at the same, or nearly the same angle to the orbit and to the ecliptic, which angle is about twenty-nine or thirty degrees. The *nodes* of the rings lie in  $190^{\circ}$  and  $550^{\circ}$  of longitude, which correspond to the twentieth degree of Virgo and the twentieth of Pisces. When, therefore, the planet is in these points, the rings entirely disappear, because the thin edge of the outer ring only is turned toward our eye, and every trace of it is lost for some time, except the shadow of it, which appears like a dark belt across the planet. This disappearance happens once every fifteen years, but frequently with different circumstances. Two disappearances and two reappearances may occur in the same year, but never more. When Saturn is in the longitude above stated, the plane of the rings passes through the sun, and, the light then falling upon it edge-wise, it is to us no longer visible. The rings likewise disappear when their plane passes through the earth; for its edge being then directed to the eye, and being too fine to be seen, the planet appears quite round and unaccompanied with its rings. When the earth is placed on the side of the rings which is turned from the sun, we have a third cause of its disappearance. As the planet passes from the ascending to the descending node of the rings, the *northern* side of their plane is turned toward the sun. As it passes from the descending to the ascending node, the *southern* side of the rings is enlightened. In proportion as it recedes from these nodes, the rings appear to widen and to present a broader ellipsis, until it arrives at  $90^{\circ}$  from either node, or in  $80^{\circ}$  or  $260^{\circ}$  of longitude, corresponding to  $20^{\circ}$  of Gemini and  $20^{\circ}$  of Scorpio; at which time the rings will be seen to the greatest advantage, and appear almost surrounding the globe of Saturn. At the time of the greatest opening of the rings, their shorter diameter appears exactly one-half of the longer diameter.

The following figures represent the different appearances of the rings, during half the period of the revolution of Saturn, as seen through good telescopes. Fig. 60 shows the appearance of Saturn when the plane of the ring is parallel to the line of vision, and its thin edge turned to the eye. In this manner the planet appeared during the months of October, November, and part of December, 1832, when nothing was perceptible except the dark shade across its disc, as represented in the figure. The first time the weather permitted observations on Saturn about this period was December 27, when I perceived the ring, with a power of 180, appearing like a line thread of light on each side of the planet, as represented Fig. 61. About the beginning of October the plane of the ring passed through the center of the sun. At that time the inhabitants of Saturn, who had previously been in darkness, would perceive the margin of the sun projecting over the

edge of the ring like a brilliant streak of light, and, in the course of about four of our days, or nine days of Saturn, the whole body of the sun would appear above the plane of the ring, gradually rising a little higher every day, as he does after the 21st March to the north pole of the earth. The ring began to appear a little larger during the months of January, February, and March, 1833; but in April it again disappeared, as the earth was then in the plane of the ring, and it continued invisible until near the end of June. After which it again appeared, as represented in Fig. 61, and will now continue visible until the

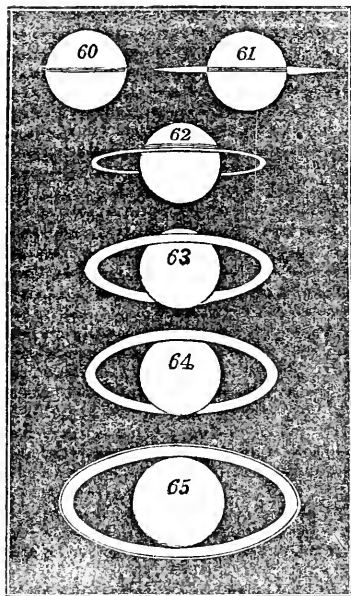

year 1847, when it will again disappear. In about a year after its second disappearance, it appeared as in Fig. 62. In about a year and a half afterward the opening between the rings appeared wider, as in Fig. 63; and in 1837 it appeared as in Fig. 64. In Fig. 65 the rings are represented at the utmost extent in which they are ever seen, along with the dark space that separates the two rings, which can only be distinguished by a telescope magnifying from 220 to 300 times. In this position it will be seen in 1849; after which it will pass through all the gradations here represented, appearing narrower every year until 1847, when it will be seen as in Fig. 61; soon after which it will entirely disappear, and the planet will be seen as if divested of its ring, as represented in Fig. 60. Such are the various aspects under which Saturn and his rings appear, as viewed through powerful telescopes.

#### IX. ON THE PLANET URANUS.

Since the time of Newton, when the physical causes of the celestial motions began to be studied and investigated, astronomers have had their attention directed to the power or influence which the planetary bodies exert upon each other. This power is termed attraction or gravitation, and is inherent in all material substances, so far as our knowledge extends. It is exerted in proportion to the quantity of matter and the distances of the respective bodies; the planets, in their nearest approach to each other, causing some slight devia-

tions in their orbits and motions. Some disturbances or inequalities in the motions of Jupiter and Saturn, which could not be accounted for from the mutual action of these planets, led certain astronomers to conclude that another planet of considerable magnitude existed beyond the orbit of Saturn, by the action of which these irregularities were produced. It was not, however, until near the close of the eighteenth century that this happy conjecture was realized and confirmed.—To the late Sir W. Herschel astronomy is indebted for discovering a new primary planet, which had been previously unknown to all astronomers.

This illustrious astronomer, when residing in Bath, had constructed reflecting telescopes of a larger size and with higher powers than any that had been previously in use, and had devoted his unwearied attention to celestial observations.—While pursuing a design which he had formed, of making minute observations on every region of the heavens, on the 13th of March, 1781, while examining, with one of his best telescopes, the constellation of Gemini, he observed a star near the foot of Castor, the light of which appeared to differ considerably from that of the neighboring stars, or those which he found described in catalogues. On applying a higher magnifying power it appeared evidently to increase in diameter; and two days afterward he perceived that its place was changed, and that it had moved a little from its former position. From these circumstances he concluded that it was a comet, and sent an account of it as such to the astronomer royal. As a comet, however, it seemed particularly singular that no tail or nebulous appearance could be perceived; on the contrary, it was found to show with a faint steady light, somewhat paler than that of Jupiter. The account of this discovery soon spread throughout Europe, and was confirmed by observations made at Paris, Vienna, Milan, Pisa, Berlin, and Stockholm. The star was for some time generally considered as an extraordinary comet, free of all nebulosity, and astronomers were occupied in determining the parabolic elements of its course. “The President Bochart de Saron, of the Academy of Sciences of Paris, and Lexel, an astronomer of St. Petersburg, who was in London at the time, were the first who discovered its circular form, and calculated the dimensions of its orbit. It was no longer doubted that Herschel’s star was a new planet; and all subsequent observations verified this unexpected result.\* We have here a striking proof of the perfection of modern theories; for the laws regulating the motion of this new planet were determined before it had accomplished the twentieth part of its course, and that motion was not less accurately known than that of other planets which had been observed during so many centuries. Since its discovery to the present time, it has not yet moved much more than two-thirds of a revolution round the sun; and yet its motions are calculated, and its place in the heavens predicted, with as much accuracy and certainty as those of the other planets, a circumstance which demonstrates the precision of modern astronomers, and which should lead the unskillful in astronomy to rely on the deductions of this science, however far they may transcend their previous conceptions.

When the motion of this new planet was calculated, the points of the heavens which it successively occupied during the preceding century

\* Biographical Memoir of Sir W. Herschel, by Baron Fourier. Read to the Royal Academy of Sciences, June 7, 1824.

could be pointed out; and it occurred to some astronomers that it might possibly have been observed before, though not known to be a planet. Mr. Bode, of Berlin, who had just published a work containing all the catalogues of zodiacal stars which had appeared, was induced to consult these catalogues in order to discover whether any star marked by one astronomer, and omitted by another, might not be the new planet in question. In the course of this inquiry he found that the star No. 964 in Mayer's catalogue had been unobserved by others, and observed only once by Mayer himself, so that no motion could have been perceived by him. On this Mr. Bode immediately directed his telescope to that part of the heavens where he might expect to find it, but without success. At the same time he found, by calculation, that its apparent place in the year 1756 ought to have been that of Mayer's star, and this was one of the years in which he was busied in his observations; and, on further inquiry, it was found that the star 964 had been discovered by Mayer on the 15th of September, 1756; so that it is now believed that this star was the new planet of Herschel. It appears likewise that this star was seen several times by Flamsteed, the astronomer royal, in the year 1690; once by Bradley; and eleven times by Lemonnier; all of whom considered it as one of the fixed stars, but never suspected that it was a planetary body. The discovery of this planet enlarges our views of the extent of the solar system, and of the quantity of matter it contains, far more than if planets equal to Mercury, Venus, the Earth, the Moon, Mars, Vesta, Juno, Ceres, and Pallas, were to be added to that system; for, although it is scarcely distinguishable by the naked eye on the vault of heaven, it is more than twenty times larger than all these bodies taken together.

After this body was ascertained to belong to the planetary system, it became a subject of consideration by what name it should be distinguished.—The old planets were distinguished by names borrowed from the heathen deities, a nomenclature which, perhaps, it might now be expedient to change; but Galileo and Cassini gave to the celestial bodies they discovered the names of the princes who had patronized their labors. Hence Galileo, when he had discovered the satellites of Jupiter, sent his drawings of them to his patron, Cosimo Medici, Grand Duke of Tuscany, in honor of whom he called them *Medicean stars*; and Cassini named the satellites of Saturn which he discovered after Louis XIV. In imitation of these discoveries, Sir W. Herschel named his newly-discovered planet *Georgian Sidus*, in honor of his patron George the Third. But foreign astronomers, for a considerable time, gave it the name of *Herschel*, in honor of the discoverer; but afterward hesitated between the names *Cybele*, *Neptune*, and *Uranus*. This last name, derived from one of the Nine Muses who presided over astronomy, ultimately prevailed, and will probably distinguish this planet in future generations, unless the present nomenclature of the planets be abolished.

*Distance and Period of Uranus.*—Uranus is the most distant planet of the solar system, so far as our knowledge yet extends; although it is by no means improbable that planets may exist even beyond its orbit, distant as it is; for comets pass far beyond the limits of this planet, and again return to the vicinity of the sun. Its distance from the sun, in round numbers, is 1,800,000,000; that is, eighteen hundred millions of miles, which is double the distance of the planet Saturn.—

When nearest the earth, it is distant from us about 1,705,000,000 of miles. In order to acquire a rude conception of this distance, let us suppose a steam-carriage to set out from the earth, and to move, without intermission, twenty miles every hour, it would require more than nine thousand, seven hundred and thirty years before it could reach the planet Uranus, so that, although the journey had been commenced at the creation of our globe, it would still require more than three thousand seven hundred years to arrive at its termination. Even a cannon ball, flying at the rate of twelve thousand miles every day, would require three hundred and eighty-nine years to reach the nearest point of the orbit of this planet. Yet the comet which appeared in 1835, in all probability, pursues its course far beyond the orbit of Uranus, and will, doubtless, visit this part of our system again, as it has done before, within the space of seventy-six years, although it must move more than double the above distance before it returns. The *circumference* of the orbit in which Uranus revolves about the sun is 11,314,000,000 of miles, through which it moves in 30,686 mean solar days, or about eighty-four years. It is the slowest moving planet in the system, and yet it pursues its course at the rate of 15,000 miles every hour.—Were a steam-carriage to move around the immense orbit of this planet at the rate above stated, it would require no less than sixty-four thousand, five hundred and seventy years before this ample circuit could be completed; and yet a globe eighty times larger than the earth finishes this vast tour in eighty-four years! This planet doubtless revolves round its axis as the other planets do, but the period of its rotation is as yet unknown. Its great distance from the earth prevents us from observing any spots or changes on its surface by which its rotation might be determined. La Place concludes, from physical considerations, that it revolves about an axis very little inclined to the ecliptic; and that the time of its diurnal rotation cannot be much less than that of Jupiter or Saturn.

*Magnitude and Dimensions of Uranus.*—This planet is about 35,000 miles in diameter, and 110,000 miles in circumference, being about eighty-one times larger than the earth, and four thousand times larger than the moon. Its surface contains 3,848,460,000 of square miles, which is 19 times the area of our globe, and 78 times the area of all the habitable portions of the earth. At the rate of population formerly stated, 280 to a square mile, it could, therefore, accommodate 1,077,565,800,000, or more than one billion of inhabitants, which is one thousand three hundred and forty-seven times the population of our globe. So that this planet, which escaped the notice of astronomers for more than five thousand years, forms a very considerable portion of the solar system and of the scene of the Divine government.

*Proportion of Light on Uranus.*—As this planet is nineteen times farther from the sun than the earth is, and as the square of 19 is 361, the intensity of light on its surface will be three hundred and sixty times less than what we enjoy. Yet this quantity of light is equal to what we should have from the combined effulgence of three hundred and forty-eight full moons; and, with a slight modification of our visual organs, such a proportion of light would be quite sufficient for all the purposes of vision. Though the light of the sun flies eighteen hundred millions of miles before it reaches this planet, and returns again by reflection nearly the same distance before it reaches the

earth, yet it is distinctly visible through our telescopes, and sometimes even to the naked eye; and Uranus, with a moderate magnifying power, appears about as bright as Saturn. How small a quantity of solar light may suffice for the purpose of vision will be obvious by attending to the following circumstance: In the late solar eclipse which happened on the 15th of May, 1856, little more than the one-twelfth part of the sun was visible at those places where the eclipse was annular. Almost every person imagined that a dismal gloom and darkness would ensue, yet the diminution of light appeared no greater than what frequently happens in a cloudy day. At the time of the greatest-obscurtion there was more than half the light which falls upon Uranus, and all the objects of the surrounding landscape, though somewhat deficient in brilliancy, were distinctly perceived. There can be no doubt that the organs of vision of the inhabitants of the different planets, being formed by Divine wisdom, are exactly adapted to the objects amid which they are placed, and the quantity of light reflected from them; and there may be innumerable modes, unknown to us, by which this end may be effected. We can easily conceive, that if the pupils of our eyes were rendered capable of a greater degree of expansion than they now possess, or were the *retina*, on which the images of objects are depicted, endowed with a greater degree of nervous sensibility, so as to be more easily affected by the impulses of light, we might perceive as much splendor on all the objects connected with Uranus, were we placed on that planet, as we now do on the scenery around us during the brightest days of summer. When we pass from the light of the sun into a darksome apartment, on our first entrance we can scarcely distinguish any objects with distinctness; but after remaining five or six minutes, until the pupil has time to expand, every object around us is readily perceived; and, from the same cause, nocturnal animals can pursue their course with ease and certainty amid the deepest shades of night; so that the inhabitants of the most distant planet of our system, although it were removed from the sun to double the distance of Uranus, might perceive objects with all the distinctness requisite for the purposes of vision; and if the pupils of the eyes of such beings be much more expansive than ours (as is probably the case), it is highly probable they will be enabled to penetrate much farther into the celestial regions, and to perceive the objects in the firmament with much greater distinctness and "space-penetrating power" than we can do, even with the aid of instruments. It is likewise probable

Fig. 66.

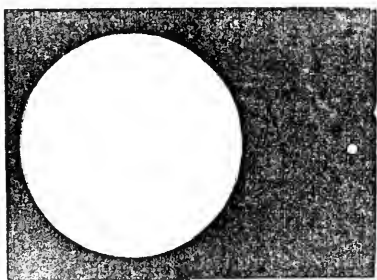

that the objects on the surface of the more distant planets of our system are fitted to reflect the rays of light with peculiar brilliancy. Hence we

find that the light of Uranus, though descending upon us from a region 900 millions of miles farther than Saturn, appears as vivid as the light which is reflected to us from that planet. The apparent diameter of the sun, as seen from Uranus, is only 1 minute, 38 seconds; whereas his mean apparent diameter as seen from the earth is 32 minutes, 3 seconds; consequently this orb, as viewed from this planet, will appear very little larger than Venus appears to us in her greatest brilliancy, or Jupiter when near his opposition. The foregoing figure represents to the eye the apparent size of the sun as seen from Uranus and from the earth, the small circle representing his size as seen from Uranus.

*Temperature of Uranus.*—If heat followed the same law as the propagation of light, and decreased as the square of the distance of the planet from the sun increased, then the surface of the planet Uranus would be a cold region indeed, in which no life or animation, such as we see around us, could exist. Baron Fourier, in his "Memoir of Herschel," says, "Its temperature is more than forty degrees below that of ice;" and if the degrees of Reaumur's thermometer be meant, this temperature will correspond to one hundred and twenty-two degrees below the freezing point of Fahrenheit; a cold enough region, truly. In accordance with such representations, the poets of the last century expatiated on the cold temperature of *Saturn* in such strains as the following:

"When the keen north with all its fury blows,  
Congeals the floods, and forms the fleecy snows,  
'Tis heat intense to what can there be known;  
Warmer our poles than is its burning zone.  
Who there inhabit must have other powers,  
Juices, and veins, and sense, and life, than ours.  
One moment's cold, like theirs, would pierce the bone,  
Freeze the heart's blood, and turn us all to stone."

BAKER'S *Universe*.

This, it must be admitted is a *very cold* poetic strain, almost sufficient to make one shiver, and to freeze our very thoughts; and if such a description were applicable to Saturn, it is much more so to the planet Uranus, at double the distance.—But I presume it is more in accordance with poetic license than with the deductions of sound philosophy. We have no valid reason to conclude that the degree of heat on the surfaces of the different planets is inversely proportional to the squares of their respective distances from the sun. The sun is to be considered chiefly as the great storehouse of *light*, and it may likewise be viewed as the great agent in the production of heat, without supposing it to be an enormous mass of fire, which the common opinion seems to take for granted. Its rays produce heat chiefly by exciting an insensible action between *caloric* and the particles of matter contained in bodies; and *caloric* appears to be a substance universally diffused throughout nature. If the degree of heat were in proportion to the distance from the sun, why should the upper regions of the atmosphere be so intensely cold? Why should the tops of lofty mountains be crowned with perpetual snows, while the plains below are scorched with heat?—Why should an intense cold be felt in the latitude 40°, when a comparative mildness is experienced in the latitude of 56°? In the state of Connecticut, North America, in January, 1835, the thermometer ranged from *minus* 25° to 27° of Fahrenheit; while in Scotland, during the same period, it was seldom so low as the freezing point.—But as I have already thrown out some remarks on this subject when describing the planet Mercury, I need not enlarge (see page 28). In order to form correct ideas of the distribution of heat

among the planetary bodies, we have only to suppose that the Creator has proportioned the quantity of caloric (or that which produces sensible heat) to the distance at which every planet is placed from the sun, so that a large quantity exists in Saturn and a smaller quantity in Mercury. If, therefore, the quantity of caloric connected with Uranus be in proportion to its distance from the sun, there may be as much warmth experienced in that distant region of the solar system as in the mildest parts of our temperate zones. So that we are under no necessity of associating the frigid and gloomy ideas of the poet with our contemplations of this expansive globe. At all events, we may rest assured that the Creator, whose wisdom is infinite in its resources, and whose "tender mercies are over all his works," has adapted the structure and constitution of the inhabitants of every planet to the nature and circumstances of the habitation provided for them, so as to render every portion of his dominions a comfortable abode for his intelligent offspring; provided they do not frustrate his benevolent designs (as has been done in our world) by their rebellion and immoral conduct. For in no region of the universe, whatever may be its physical arrangements, can true happiness be enjoyed, unless love to God and love to all surrounding intelligences form the grand principles of action, and be uniformly displayed in every intercourse and association, and amid all the ramifications of moral conduct. On this basis chiefly rests the happiness of the intelligent universe; and, wherever principles directly opposite to these prevail among any order of intellectual beings, whatever may be the structure or scenery of their habitation, misery and moral disorder must be the inevitable consequence.

The following additional particulars may be stated in relation to this planet: Its *density* is reckoned to be nearly equal to that of water. A body weighing one pound on the earth's surface would weigh only fourteen ounces, fourteen drachms, if removed to Uranus. The *eccentricity* of its orbit is 85,000,000 of miles, which is about the 1-42d part of its diameter. Its mean *apparent diameter*, as seen from the earth, is about four seconds. The *inclination of its orbit* to the ecliptic is forty-six minutes, twenty-six seconds, so that it is never much more than three-fourths of a degree from the ecliptic. This inclination is less than that of any of the other planetary orbits. Six satellites are supposed to be connected with Uranus, but their periods and other phenomena have not yet been accurately ascertained.

In the preceding pages I have given a brief sketch of the principal phenomena connected with the *primary* planets of our system. Whether any other planets beside those specified belong to this system is at present unknown. We have no reason to believe that the boundaries of the planetary system are circumscribed within the range of our discoveries or the limits of our vision. Within the space of little more than half a century, the limits of this system have been expanded to our view to double the extent which they were formerly supposed to comprehend. Instead of an area of only 25,400,000,000 of square miles, it is now found to comprise an extent of 101,700,000,000 of square miles, which is four times the dimensions formerly assigned to it. There would be no improbability in conceiving it extended to at least triple these dimensions. Within the space of twenty-six years, from 1781

to 1807, no fewer than five primary planets and eight secondaries were discovered, beside a far greater number of comets than had ever before been detected within a similar lapse of years; and therefore it would be obviously rash and premature to conclude that we have now discovered all the moving bodies of our system. Far beyond the limits of even Uranus other planets yet unknown may be performing their more ample circuits around the sun; for we know, from the case of comets, that even throughout those distant regions his attractive power and influence extend. In the immense interval of 900,000,000 of miles between the orbits of Saturn and Uranus, one, if not two planets may possibly exist, though they have hitherto eluded the observation of astronomers. In order to detect such bodies, if any exist, it would be requisite to survey, more minutely than has yet been done, a zone of the heavens extending at least twenty degrees on each side of the ecliptic, marking exactly the minutest objects in every part of it which the most powerful telescopes can enable us to descry. After which a second survey should be made to ascertain if any of the bodies formerly observed be found missing or have shifted their position. It might likewise be expedient to compare with new observations the stars marked in all the celestial atlases that have hitherto been published, and to note particularly those which are wanting where they were formerly marked, and those that have appeared in certain places where they were formerly unobserved. If a taste for celestial investigations were more common among mankind, and were the number of observers indefinitely increased, there would be no great difficulty in accomplishing such an object; for certain small portions of the heavens might be allotted to different classes of observers, who might proceed simultaneously in their researches, and in a comparatively short period the whole survey might be completed.

It is not improbable that a planet may exist within the space of 37 millions of miles which intervenes between the orbit of Mercury and the sun. But such a body could never be detected in the evening after sunset, as its greatest elongation from the sun could not be supposed to be more than ten or twelve degrees, and, consequently, it would descend below the horizon in about half an hour after sunset, and before twilight had disappeared. The only chance of detecting such a planet would be when it happened to transit the sun's disc; but as this would happen only at distant intervals, and as it might make the transit in cloudy weather, or when the sun is absent from our hemisphere, there is little prospect of our discovering such a body in this way. It might be of some importance, however, that those who make frequent observations on the sun should direct their attention to this circumstance; as there have been some instances in which dark bodies have been observed to move across the sun's disc in the space of five or six hours, when no other spots were visible. An opaque body of this description was seen by Mr. Lloft and others on the 6th of January, 1818, which moved with greater rapidity across the solar disc than Venus in her transit in 1769. It is possible that a planet within the orbit of Mercury might be detected in the day-time, were powerful telescopes applied to a space of the heavens about ten or twelve degrees around the sun. Small stars have been seen even at noonday with powerful instruments, and, consequently, a planet even smaller than Mercury might be perceived in the day-time. In this case, a round opaque body would require to be placed

at a considerable distance from the observer, so as completely to intercept the body of the sun, and about a degree of the heavens all around him; and every portion of the surrounding space, extending to at least twelve degrees in every direction, should then be carefully and frequently examined. Such observations, if persevered in, would undoubtedly afford a chance of detecting any revolving body that might exist within such a limit. But I may afterwards have an opportunity of describing more particularly the observations, and the mode of conducting them, to which I allude.

#### X. THE SUN.

Having taken a cursory survey of the most prominent particulars connected with the primary planets, I shall now proceed to a brief description of the sun, that magnificent luminary on which they all depend, from which they derive light, and heat, and vivifying influence, and by whose attractive energy they are directed in their motions and retained in their orbits. Before proceeding to a description of the particular phenomena connected with the sun, it may be expedient briefly to describe some of his *apparent motions*.

*Apparent Motions of the Sun.*—The most obvious apparent motion of the sun, which is known to every one, is, that he appears to rise in the morning in an easterly direction, to traverse a certain portion of the sky, and then to disappear in the evening in a direction toward the west. Were we to commence our observations on the 21st of December, in the latitude of  $52^{\circ}$  north, which nearly corresponds to that of London, we should see the sun rising near the south-east point of the horizon, as at *S E*, Fig. 67, describing a comparatively small curve above the horizon, from *S E* to *S W*, in the southern quarter of the heavens, and setting at *S W*, near the south-west. At this season the sun remains only between seven and eight hours above the horizon; and when he arrives at *S*, at midday, which is the highest point of his elevation, he is only about fourteen degrees above the horizon, which may

Fig. 67.

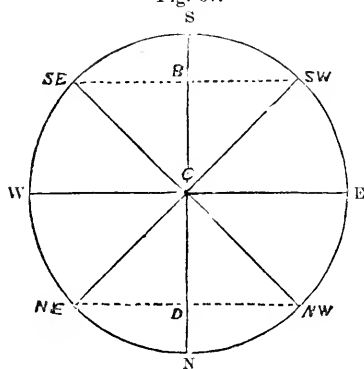

be represented by the line *S B*. After disappearing in our horizon in the evening, he describes the large curve from *S W* to *W*, *N*, and *E*, until he again arrives in the morning near the point *S E*. All this curve is described *below* our horizon, and, therefore, the nights at this season are much longer than the days. After this period the sun rises every day at points a little farther to the north, between *S E* and *E*, and sets in corresponding points in the west, between *S W* and *W*, until the 21st of March, when he rises at the point *E*, due east, and sets due west at the point

*W*. At this time he moves through the semicircle *E*, *S*, *W*, and at noon he rises to the elevation of thirty-eight degrees above the southern horizon, which may be represented by the line *S C*. This is the period of the vernal equinox, when there is equal day and night throughout every part of the earth, the sun being twelve hours above and twelve hours below the horizon. After this period the sun rises to the north of the easterly point, and sets to the north of the westerly, and the length of the day rapidly advances until the 21st of June, when he rises near the north-east point, *N E*, and sets near the north-west point, *N W*, describing the large curve from *N E* to *E*, *S*, *W*, and *N W*. This period of the year is called the summer *solstice*, when the days are longest, at which time the sun rises at noon to an elevation of  $61\frac{1}{2}$  degrees above the horizon, which may be represented by the line *S D*, and he continues above the horizon for nearly seventeen hours. The length of the nights at this time is exactly the same as the length of the days on the 21st of December. The sun's nocturnal arch, or the curve he describes below the horizon, is that which is represented in the lower part of the figure from *N W* to *N E*. In more southern latitudes than fifty-two degrees, the sun rises to a higher elevation at noon; and in higher latitudes his meridian altitude is less than what is stated above. From the time of the summer solstice the days gradually shorten; the sun rises in a more southerly direction until the 23d of September, which is called the *autumnal equinox*, when he again rises in the eastern point of the compass, and every succeeding day at a point still farther to the south, until, on the 21st of December, or the *winter solstice*, he is again seen to rise near the south-east, and afterward to pass through all the apparent variations of motion above described.

Were we residing in southern latitudes, such as those of Buenos Ayres, the Cape of Good Hope, or Van Dieman's Land, the apparent motions of the sun would be somewhat different. Instead of beholding the sun moving along the *southern* part of the sky from the left hand to the right, we should see him direct his course along the northern part of the heavens from the right hand to the left. In other respects his apparent motions would nearly correspond to those above described. Were we placed in countries under the equator at the time of the equinoxes, the sun at midday would shine directly from the zenith, at which time objects would have no shadows. At all other times the sun is either in the northern or the southern quarter of the heavens. During the one-half of the year he shines from the north, and the shadows of objects fall to the south; during the other half he shines from the south, and the shadows of all objects are projected toward the north. This is a circumstance which can never occur in our climate or in any part of the temperate zones. At the equator, too, the days and nights are of the same length, twelve hours each, throughout the whole year. Were we placed at the *poles*, the motion of the sun would present a different aspect from any of those we have described. At the north pole, on the 21st of March, we should see a portion of the sun's disc appear in the horizon after a long night of six months. This portion of the sun would appear to move quite round the horizon every twenty-four hours; it would gradually rise higher and higher until the whole body of the sun made its appearance. As the season advanced, the sun would appear to rise higher and higher until he attained the altitude of  $23\frac{1}{2}$  degrees above the



horizon, which would take place on the 21st of June; after which his altitude would gradually decline until the 23d of September, when he would again appear in the horizon. During the whole of this period of six months there is perpetual day, the stars are never seen, and the sun appears to go quite round the heavens every twenty-four hours without setting, in circles nearly parallel to the horizon. After the 23d of September the sun disappears, and a night of six months succeeds, which is occasionally enlivened by the moon, the stars, and the coruscations of the *aurora borealis*, during which period the south pole enjoys all the splendor of an uninterrupted day. In all places within the polar circles, the length of the longest day varies from twenty-four hours to six months. In the northern parts of Lapland, for example, the longest day is about six weeks; during this time the sun appears to move round the heavens without setting; but at noon, when he comes to the meridian, he is about 40 degrees above the *southern* horizon, and twelve hours afterward he appears elevated about six degrees above the *northern* horizon, from which point he again ascends until he arrives at the southern meridian.

Such are the apparent *diurnal* motions and general aspects of the sun in different parts of the earth, which are owing partly to the inclination of the axis of the earth to the plane of the ecliptic, and partly to the different positions in which a spectator is placed in different zones of the globe. It is almost needless to remark, that these motions of the sun are not *real*, but only *apparent*. While presenting all these varieties of motion, he is still a quiescent body in the center of the planetary system. By the rotation of the earth round its axis, from west to east, every twenty-four hours, all these apparent motions of the sun are produced. This we have already endeavored to prove in chap. i, pp. 16-17.

Beside the apparent diurnal motion now described, there is another apparent motion of the sun in a contrary direction, which is not so much observed, and that is, his apparent motion from *west to east* through the whole circle of the heavens, which he accomplishes in the course of a year. This motion manifests itself by the appearance of the heavens during the night. The stars which lie near the path of the sun, and which set a little time after him are soon lost in his light, and after a short time reappear in the east a little before his rising. This proves that the sun advances toward them in a direction contrary to his diurnal motion; and hence we behold a different set of stars in our nocturnal sky in summer and in winter. This apparent revolution of the sun is produced by the *annual* motion of the earth round the sun, of which I have already given an explanation (chap. i, p. 17,) along with certain demonstrative proofs that the sun is the center of the planetary system (see also chap. ii, pp. 22-26).

*Distance and Magnitude of the Sun.*—To find the exact distance of the sun from the earth is an object which has much interested and engaged astronomers for a century past. The angle of parallax being so small as about eight and a half seconds, rendered it for some time difficult to arrive at an accurate determination on this point, until the transits of Venus in 1761 and 1769. From the calculations founded upon the observations made on these transits, it has been deduced that the distance of the sun is about 95,000,000 of miles. This distance is considered by La Place and other astronomers to be within the 1-87th part of the true distance, so that it cannot be much below 94 mil-

lions on the one hand, nor much above 96 millions on the other. Small as this interval may appear when compared with the vast distances of some of the other celestial bodies, it is, in reality, a most amazing distance when compared with the spaces which intervene between terrestrial objects; a distance which the mind cannot appreciate without a laborious effort. It is thirty-one thousand six hundred times the space which intervenes between Britain and America; and were a carriage to move along this space at the rate of 480 miles every day, it would require 542 years before the journey could be accomplished.

The *magnitude* of this vast luminary is an object which overpowers the imagination. Its diameter is 880,000 miles; its circumference, 2,764,600 miles; its surface contains 2,432,800,000,000 of square miles, which is twelve thousand three hundred and fifty times the area of the terraqueous globe, and nearly fifty thousand times the extent of all the habitable parts of the earth. Its solid contents comprehend 356,818,739,200,000,000,\* or more than three hundred and fifty-six thousand billions of cubical miles. Were its center placed over the earth, it would fill the whole orbit of the moon, and reach 200,000 miles beyond it on every hand. Were a person to travel along the surface of the sun, so as to pass along every square mile on its surface, at the rate of thirty miles every day, it would require more than two hundred and twenty millions of years before the survey of this vast globe could be completed. It would contain within its circumference more than thirteen hundred thousand globes as large as the earth, and a thousand globes of the size of Jupiter, which is the largest planet of the system. It is more than five hundred times larger than all the planets, satellites, and comets belonging to our system, vast and extensive as some of them are. Although its density is little more than that of water, it would weigh 3360 planets such as Saturn, 1067 planets such as Jupiter, 329,000 globes such as the earth, and more than *two millions* of globes such as Mercury, although its density is nearly equal to that of lead. Were we to conceive of its surface being peopled with inhabitants at the rate formerly stated, it would contain 681,184,000,000,000, or more than six hundred and eighty billions, which would be equal to the inhabitants of *eight hundred and fifty thousand worlds* such as ours.

Of a globe so vast in its dimensions, the human mind, with all its efforts, can form no adequate conception. If it is impossible for the mind to take in the whole range of the terraqueous globe, and to form a comprehensive idea of its amplitude and its innumerable objects, how can we ever form a conception, approaching to the reality, of a body one million three hundred thousand times greater? We may express its dimensions in figures or in words, but in the present state of our limited powers we can form no mental image or representation of an object so stupendous and sublime. Chained down to our terrestrial mansion, we are deprived of a sufficient range of prospect, so as to form a substratum to our thoughts, when we attempt to form conceptions of such amazing magnitudes. The imagination is overpowered and bewildered in its boldest efforts, and drops its wings before it has realized the ten thousandth part of the idea which it

\* In some editions of the "Christian Philosopher," under the article *Astronomy*, this number is inaccurately stated; and the number which follows, *two thousand millions*, should be *two hundred millions*.

attempted to grasp. It is not improbable that the largest ideas we have yet acquired or can represent to our minds of the immensity of the universe are inferior to a *full and comprehensive idea* of the vast globe of the sun in all its connections and dimensions; and, therefore, not only must the powers of the human mind be invigorated and expanded, but also the limits of our intellectual and corporeal vision must be indefinitely extended, before we can grasp the objects of overpowering grandeur which exist within the range of creation, and take an enlightened and comprehensive view of the great Creator's empire. And as such endowments cannot be attained in the present state, this very circumstance forms a presumptive argument that man is destined to an immortal existence, where his faculties will be enlarged and the boundaries of his vision extended, so as to enable him to take a large and comprehensive view of the wonders of the universe, and the range of the Divine government. In the meantime, however, it may be useful to allow our thoughts to expatiate on such objects, and to endeavor to form as comprehensive an idea as possible of such a stupendous luminary as the sun, in order to assist us in forming conceptions of objects still more grand and magnificent; for the sun which enlightens our day is but one out of countless millions of similar globes dispersed throughout creation, some of which may far excel it in magnitude and glory.

*Rotation of the Sun.*—This luminary, although it is placed in the center of the system, in the enjoyment of perpetual day, and stands in no need of light from any other orb, yet is found to have a rotation round its axis. This circumstance seems to indicate that motion is essential to all the bodies of the universe, whether revolving in orbits around another body, or acting as the centers of light and attractive influence. And from what we know of the more distant bodies in the heavens, we have reason to believe that there is none of them in a state of absolute quiescence, but that they are all in incessant motion, either round their axes, or around a distant center. The rotation of the sun was discovered by the motion of certain dark spots across its disc. These spots appear to enter the disc on the east side, to move from thence with a velocity continually increasing until they arrive at the middle of the disc; they then move slower and slower until they go off at the sun's western limb; after which they disappear for about the same space of time they occupied in crossing the disc, and then enter again on the eastern limb and move onward in the same track as before, unless they suffer a change, as frequently happens, after they disappear from the western limb. The apparent *inequality* in the motion of the spots is purely optical, and is owing to the oblique view we have of the parts of a globe which are near the margin; but the motion is such as demonstrates that the spots are carried round with a uniform and equable motion.—From the motion of these spots we learn, 1. That the sun is a globe, and not a flat surface; 2. That it has a rotation round its own axis; and, 3. That this rotation is performed in the same direction as the rotation of the planets and their annual revolutions, namely, according to the order of the signs of the zodiac. The time which a spot takes in moving from the eastern to the western limb is thirteen days and nearly sixteen hours, and, consequently, the whole apparent revolution is twenty-seven days and nearly eight hours. But this is not the true period of the sun's rotation; for as the earth has, during this time, advanced in its

orbit from east to west, and in some measure followed the motion of the spot, the real time in which the spots perform their revolutions is found, by calculation,\* to be twenty-five days, ten hours. Every part of the sun's equator, therefore, moves at the rate of 4532 miles every hour. The axis of the sun, round which this revolution is performed, is inclined 7 degrees 20 minutes to the ecliptic.

*The Solar Spots, and the Physical Construction of the Sun.*—Although the sun is the fountain of light, and is incessantly pouring a flood of radiance over surrounding worlds, yet the nature of this vast luminary, and the operations which are going on upon its surface and adjacent regions, are in a great measure involved in darkness.—Before stating any opinions on this subject, it may be proper, in the first place, to give a brief description of the phenomena which have been observed on the surface of the sun. The first and most striking phenomenon is the dark spots to which we have alluded. These spots are of all sizes, from one twenty-fifth part of the sun's diameter to the one five-hundredth part and under. The larger spots are uniformly dark in the center, and surrounded with a kind of border or fainter shade, called a *penumbra*. This penumbra, which sometimes occupies a considerable space around the dark nucleus, is frequently of a shape nearly corresponding to that of the black spot. Sometimes two or more dark spots, and a number of small ones are included within the same *penumbra*, and at other times a number of small spots in a train, forming a kind of tail, accompany the larger ones. The *number* of the spots is very various; sometimes there are only two or three, sometimes above a hundred, and sometimes none at all. *Scheiner*, who was among the first that observed these spots, remarks, that "from the year 1611 to 1629 he never found the sun quite clear of spots, except a few days in December, 1624; at other times he was able to count twenty, thirty, and even fifty spots upon the sun at a time." Afterward, during an interval of twenty years, from 1650 to 1670, it is said that scarcely any were to be seen. But, since the beginning of last century, no year has passed, so far as we know, in which spots have not been seen. I have had an opportunity of viewing the sun with good telescopes several hundreds of times, but have seldom seen his surface altogether free of spots.—In some years, however, they have been far more numerous than in others. In the beginning of 1835 comparatively few were seen, but during the latter part of it, the whole of 1836, and up to the present time (September, 1837), they have been exceedingly numerous. On the 16th of November, 1835, with an achromatic telescope, magnifying about a hundred times, I perceived about ten different clusters; and, within the limits of two of the clusters, sixty different spots were counted, and in the whole of the other clusters above sixty more; making in all about 120 spots, great and small. On the 19th of October, 1836, and the 21st of February, 1837, I counted about 130; and on a late occasion I perceived spots of all descriptions to the amount of about 150. Such a number of spots are generally arranged into ten or twelve different clusters, each cluster having one or two large spots, surrounded with a number of smaller ones. Fig. 68, represents the spots of the sun nearly as they appeared on the 19th of October, 1836, some of the smaller

\*The following is the proportion by which the true rotation is found:  $365d. 5h. 48m. + 27d. 7h. 37m. = 392d. 13h. 25m.$   
 $365d. 5h. 48m. : 27d. 7h. 37m. :: 25d. 9h. 56m. =$  the true time of the sun's rotation.

spots being omitted. The larger spots are represented on a somewhat larger scale than they should be in proportion to the diameter of the circle; but they present nearly the same relative aspect they exhibited when viewed through the telescope at the time specified. Fig. 69 shows the large spot on a larger scale; and Fig. 70 a large spot which appeared in a subsequent observation, which had a bright streak or two in the center.

The magnitude of some of the solar spots is astonishing. One of the spots seen November 16, 1835, was found to measure about the *fortieth* part of the sun's diameter; and as that diameter is equal to 850,000 miles, the diameter of the spot must have been 22,000 miles, which is nearly three times the diameter of the earth; and if we suppose it only a flat surface, and nearly circular, it contained 350,133,600 square miles, which is nearly double the area of our globe. The largest of the spots in the figure, including the penumbra, measured about the one twenty-first part of the sun's diameter; and its breadth about the 1-54th part of the same diameter; consequently the length of the spots and penumbra was 41,900 miles, its breadth 16,300, and its area 6,829,700,000 square miles, which would afford room for ten globes as large as the earth to be placed upon it. It consisted of a dark spot of a longish form, about 12,000 miles in length, and two or three smaller spots, some of them several thousand miles long, all included within one penumbra. The smallest spots we can discern on the solar disc cannot be much less than five or six hundred miles in diameter.

These spots are subject to numerous changes. When watched from day to day, they appear to enlarge or contract, to change their forms, and at length to disappear altogether, or to break out on parts of the solar surface where there were none before. Hevelius observed one which arose and vanished in the space of seventeen hours. No spot has been known to last longer than one that appeared in the year 1676, which continued upon the sun above seventy days; but it is seldom that any spots last longer than six weeks. Those spots that are formed gradually are generally gradually dissolved; those which arise suddenly are, for the most part, suddenly dissolved. Dr. Long, in his "Astronomy," vol. ii, states, that "while he was viewing the image of the sun cast through a telescope upon white paper, he saw one roundish spot, by estimation not much less in diameter than our earth, break into two, which immediately receded from one another with a prodigious velocity." The Rev. Dr. Wollaston, when viewing the sun with a reflective telescope, perceived a similar phenomenon. A spot burst in pieces while he was observing it like a piece of ice, which, thrown upon a frozen pond, breaks in pieces and slides in various directions. On the 11th of October, 1833, at 2h. 30' r. m., I observed a large spot, with several smaller ones behind it, as represented Fig. 71. Next day, at 9h. 30' r. m., the small spots marked e had entirely disappeared, and no trace of them was afterward seen. Each of these spots was more than a thousand miles in diameter, yet they were all changed in the space of twenty-

two hours. The spot marked d, near the large spot, though at least two or three thousand miles in length, disappeared about three days afterward. When any spot begins to increase or diminish, the nucleus, or dark part, and the penumbra contract and expand at the same time. During the process of diminution, the penumbra encroaches gradually upon the nucleus, so that the figure of the nucleus and the boundary between it and the penumbra are in a state of perpetual change; and it sometimes happens during these variations, that the encroachment of the penumbra divides the nucleus into two or more parts. These circumstances show that there is a certain connection between the penumbra and the nucleus; yet it is observed, that when the spots disappear the penumbra continues for a short time visible after the nucleus has vanished. It is likewise observed that the exterior boundary of the penumbra never consists of sharp angles, but is always curvilinear, how irregular soever the outline of the nucleus may be. The portions of the sun on which spots of any description are perceived lie from thirty to fifty degrees on each side of its equator. No spots are ever seen about its polar

Fig. 63.  
North.

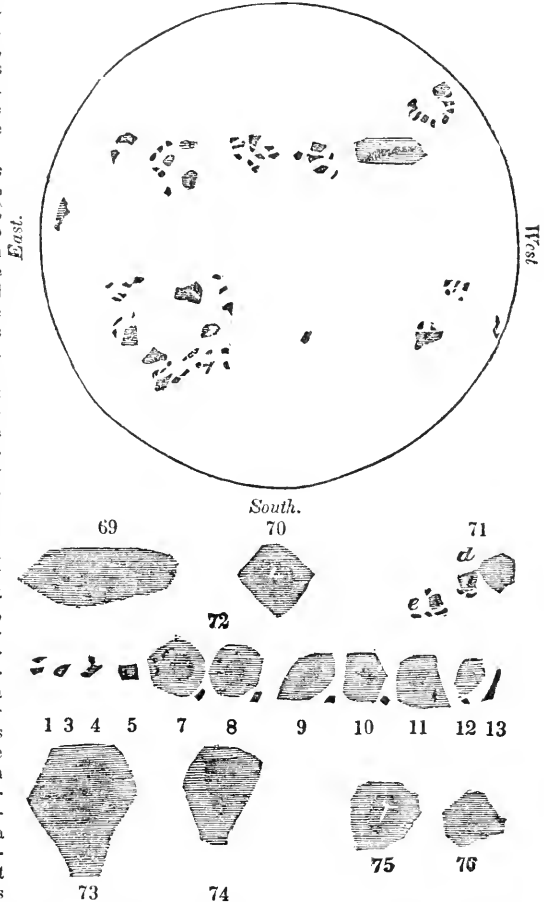

regions, though I have sometimes seen small spots as distant from the equator as sixty degrees.

Fig. 72 shows the progress of a spot across the sun's disc, from its eastern to its western limb, as

observed and delineated by Hevelius, in May, 1644. The figures refer to the number of days on which the spot was observed. On the first day of the observation, when the spot first appeared on the eastern limb, it was seen as represented at 1; the second day it was not visible, by reason of cloudy weather. The third, fourth, and fifth days it gradually increased in bulk; the sixth day it was not seen. On the tenth and following days the spot was vastly increased in bulk, with an irregular atmosphere about it and a dark central spot. Figs. 73, 74, 75, 76, are representations of spots by Sir W. Herschel. Fig. 75 shows the division of a decaying nucleus or opening, where the luminous passage across the opening resembles a bridge thrown over a hollow.

Beside the dark spots now described, there are other spots which have a bright and mottled appearance, which were formerly termed *facule*, and which Sir W. Herschel distinguished by the terms *Nodules*, *Corrugations*, and *Ridges*. These spots are chiefly to be seen near the margin of the sun, in the same latitudes in which the other spots appear. They appear first on the eastern margin, and continue visible for three or four days, but are invisible when they arrive near the middle of the disc, and when they approach near the western limb they are again distinctly visible. This circumstance shows that they are ridges or elevations, which appear in profile when near the limb, but in front or foreshortened when near the middle of the disc, so as to become invisible.—They are generally seen in the immediate neighborhood of dark spots, and in the places where spots have appeared; and hence, for several years past, when any of these *facule* or ridges have appeared on the eastern margin, I have uniformly been enabled to predict the appearance of a large spot or two within the course of twenty-four or thirty hours; and in more than twenty or thirty instances I have never been disappointed. These *facule* and ridges present a mottled and waving appearance, like that of a country with gentle elevations and depressions, and bear a strong resemblance to certain portions of that surface of the moon, particularly the more level portions of the orb, which present a number of gentle windings or elevations and depressions. And as those windings or ridges which appear on the sun are, in a clear atmosphere, as distinctly perceptible as the rough surface of the moon, they must be objects of immense extent and of very great elevation, whether they consist of luminous clouds or of more dense materials. Some of those spaces or ridges have been found to occupy a portion of the solar disc equal to seventy-five thousand miles. They extend over a large portion of the sun's surface, and their shape and position are frequently changing.

*Opinions and Deductions respecting the Nature and Constitution of the Sun.*—Having described the principal phenomena connected with this immense luminary, we may now consider what conclusions those appearances lead us to deduce respecting its construction and the processes which are going on near its surface. Very vague and foolish opinions have been entertained respecting the nature of the sun ever since the invention of the telescope. It has very generally been considered as a vast body of liquid fire; and in a large volume now before me, published only about a century ago, it is considered as the local place of *hell*. A large map of the sun, copied from the delineations of *Kircher* and *Scheiner*, is exhibited, in which the solar surface is represented as all over covered with flames, smoke, volcanoes, and

“great fountains, or ebullitions of fire and light, spread thick over the whole body of it; and in many places *dark spots*, representing dens or caverns, which may be supposed the seats of the blackness of darkness.”\* In this picture the smoke and flames are represented as rising beyond the margin of the sun about a ninth part of its diameter, or nearly 39,000 miles; a picture as unlike the real surface of the sun as the gloom of midnight is unlike the splendors of day. But, leaving such extravagant and untenable notions, even some philosophers have held opinions altogether incompatible with reason and with the phenomena presented by the sun: Galileo, Hevelius, and Maupertius considered the spots as *scoria* floating in the inflammable liquid matter of which they conceived the sun to be composed. Others have imagined that the fluid which sends forth light and heat contains a nucleus or solid globe, in which are several volcanoes, like Etna or Vesuvius, which from time to time cast forth quantities of bituminous matter up to the surface of the sun, and form those spots which are seen upon it; and that, as this matter is gradually changed and consumed by the luminous fluid, the spots disappear for a time, but are seen to rise again in the same places when those volcanoes cast up new matter. Others, again, have supposed that the sun is a fiery luminous fluid, in which several opaque bodies of irregular shapes are immersed, and that these bodies are sometimes buoyed up or raised to the surface, where they appear like spots; while others imagine that this luminary consists of a fluid in continual agitation, by the rapid motion of which some parts more gross than the rest are carried up to the surface in like manner as scum rises on the top of melted metal or anything that is boiling. The futility of all such opinions is obvious when we consider attentively all the varieties of the solar phenomena, and when we reflect on the immense magnitude both of the sun itself and of the spots which traverse its surface. What resemblance can there be between such volcanoes as Etna and Vesuvius, and spots on the sun 2,000 miles in diameter, and several times larger than the whole earth? between the vast and sublime operations going forward in this magnificent globe, and “the scum and scoria of melted metal?” We err most egregiously when we attempt to compare the substances and the puny operations which we see around us on the globe we inhabit, with what takes place on so stupendous a globe as the sun, whose constitution must be so immensely different from that of the planetary bodies, and from everything within the range of our observation on this earth. We talk of volcanoes, of boiling metals, of bituminous matter, of dens, and caverns, and fiery flames in the sun, as if they were as common there as with us; whereas there is every reason to believe that nothing similar to any of these is to be found in the constitution of this vast luminary. We might, with as good reason, attempt to compare the process of vegetation on our globe, and the tides and currents of our ocean, with what takes place on the surface of Jupiter or on the rings of Saturn. In all such cases, it is most becoming rather to acknowledge our ignorance than to caricature and degrade the sublimest works of Omnipotence by our puerile explanations and whimsical theories. The following are some of the more rational conclusions which have been deduced in reference to the constitution of the sun.

\* “An Inquiry into the Nature and Place of Hell,” By the Rev. T. Swinden, M. A., Rector of Cuxton, in Kent, 2d edit., p. 470. London, 1727.

In the first place, from a variety of observations, it is now pretty well determined that the solar spots are *depressions*, and not elevations, and that the black nucleus of every spot is the opaque body of the sun seen through an opening in the luminous atmosphere with which it is environed. This was first ascertained by numerous observations made by the late Dr. Wilson, professor of astronomy in the university of Glasgow. This conclusion is founded on the following facts: When any spot is about to disappear behind the sun's western limb, the eastern portion of the umbra first contracts in its breadth, and then vanishes. The nucleus then contracts and vanishes, while the western portion of the umbra still remains visible. When a spot comes into view on the sun's eastern limb, the eastern portion of the umbra first becomes visible, then the dark nucleus, and then the western part of the umbra makes its appearance. When two spots are near each other, the umbra of the one spot is deficient on the side next the other; and when one of the spots is much larger than the other, the union of the largest will be completely wanting on the side next the small one. From various micrometrical estimates and calculations in relation to the breadth of the umbra, and the manner of their appearance and disappearance, the doctor was led to the conclusion that the *depth* of the nucleus or dark part of the spots was, in several instances, from 2000 to nearly 4000 miles. In order to confirm his theory, he constructed a globe representing the sun, with certain hollows cut out to represent the spots or excavations, which were painted black with Indian ink, and the slope or shelving sides of the excavations were distinguished from the brightness of the external surface by a shade of the pencil, which increased toward the external border. When this artificial sun was fixed in a proper frame, and examined at a great distance with a telescope, the umbra and the nucleus exhibited the same phenomena which are observed on the real sun.\*

Sir William Herschel, with his powerful telescopes, made numerous observations on the solar spots, and arrived at the same conclusion as Dr. Wilson had done, that the dark nucleus of the spots is the opaque body of the sun appearing through the openings in its atmosphere, and that the luminous surface of the sun is neither a liquid substance nor an elastic fluid, but luminous or phosphoric clouds floating in the solar atmosphere. He conceives, from the uniformity of color in the penumbra or *shadows*, that below these self-luminous clouds there is another stratum of clouds of inferior brightness, which is intended as a curtain to protect the solid and opaque body of the sun from the intense brilliancy and heat of the luminous clouds; and that "the luminous strata are sustained far above the level of the solid body by a transparent elastic medium, carrying on its upper surface, or at some considerably lower level within its depth, a cloudy stratum, which, being strongly illuminated from above, reflects a considerable portion of the light to our eyes, and forms a penumbra, while the solid body, shaded by the clouds, reflects little or none."

What, then, are the conclusions which may be deduced in regard to the constitution of the sun? In the first place, we must admit that, at present, we know very little of the nature of this immense

luminary, and of the processes that are going forward on its surface or in its atmosphere. For there is no similar body with which we are intimately acquainted with which we can compare it, and which might enable us to form some definite conceptions of the causes which produce the phenomena it presents. But, secondly, it appears highly probable, if not absolutely certain, that the great body of the sun consists of an opaque solid globe, most probably diversified with elevations and depressions, but of the nature or qualities of this interior globe, and the materials of which it is composed, we are altogether unacquainted. Thirdly, that this opaque globe is surrounded with a body of light, which it diffuses throughout the planetary system and far beyond it; but whether this light consists of phosphoric clouds in perpetual motion, or how it is produced and kept continually in action, is only matter of conjecture. But, in whatever it consists, it is pretty evident that it forms a shell or covering around the dark body of the sun of several thousand miles in thickness. Fourthly, there are stupendous motions and operations continually going forward in connection with the surface or the luminous atmosphere of this immense body.

That extensive and amazing operations and processes are going forward on the surface of the sun, or in its immediate vicinity, appears from the immense size of both the dark and luminous spots, and the sudden and extensive changes to which they are frequently subjected. Spots have been observed on the solar disc so large as the one twentieth of the sun's diameter, and, of course, 41,000 miles in lineal extent, comprising an area of one thousand five hundred and twenty millions of square miles. Now it is known from observation that such spots seldom or never last longer than forty-four days, and, consequently, their borders must approach at the rate of at least a thousand miles every day, but in most cases with a much more rapid motion. What, then, shall we think of the motions and operations by which a large spot has been made to disappear in the course of twenty-two hours, as I have sometimes observed, yea, which have disappeared in the course of a single hour? And what shall we think of the process by which a spot as large as the earth was broken into two during the moment of observation, and made to recede from each other, as was observed both by Dr. Long and Dr. Wollaston? (See page 79.) How powerful the forces, how rapid the motions, and how extensive the changes which must have been produced in such cases! Whether we consider such changes to be produced in the solid globe of the sun, or in the luminous atmosphere with which it is environed, the scale on which such movements and operations must be conducted is immense, and altogether overpowering to the imagination. What should we think were we to behold the whole of the clouds which float in the earth's atmosphere dissipated in a moment; the continent of America detached from its basis and transported across the Atlantic; or the vast Pacific ocean, in the course of a few days, overwhelming with its billows the whole of Asia, Africa, and Europe? Amazing as such changes and revolutions would appear, there are, in all probability, operations and changes, though of a very different description, taking place on the solar surface or atmosphere upon a scale of much larger extent. It is found by calculation that the smallest space containing a visible area which can be distinctly perceived on the sun with good telescopes is about 460 miles; and a circle of this diameter contains about 166,000 square miles.

\* See an elaborate paper on this subject by Dr. Wilson, in vol. xiv of the "Philosophical Transactions;" and another, in reply to some objections of La Lande, in the volume for 1783.

Now those ridges or corrugations, formerly termed *facule*, which are seen near the sun's margin, are more than twenty times larger than such a space; they evidently appear to be elevations and depressions on the solar surface, and are almost as distinctly perceptible as the wavings and inequalities on the surface of the moon. How immensely large and elevated, then, must such objects in reality be, when we perceive their inequalities so distinctly at the distance of ninety-five millions of miles! The elevated parts of such objects cannot be less than several hundreds of miles above the level of the valleys or depressions, and extending in length several thousands of miles. Yet, sometimes in a few days, or, at most, a few weeks, these extensive objects are either dissipated or dark spots appear in their room.

It is evident, then, that stupendous powers are in action, and vast operations are going on in connection with this august luminary, far surpassing everything within the range of our contemplation in this terrestrial sphere, and of which the human mind can form no distinct conception. These operations appear to be carried forward in a systematic order, and by the regular influence of certain physical agents. But what these agents are; how they produce their effects; wherein they differ in their nature and properties from the physical agents connected with our globe; whether they be employed in keeping up a constant efflux of light and heat to the worlds which roll around; or whether their activities have any relation to intelligent beings connected with the sun, are questions which, in our present state, it is impossible to resolve. But we can easily conceive that scenes of overpowering grandeur and sublimity would be presented to view could we suppose ourselves placed in the immediate vicinity of this luminary. Were we placed within a hundred miles of the solar luminous atmosphere, where the operations which we now behold at a remote distance would be distinctly perceived, we should doubtless behold a scene of overpowering magnificence and splendor, and a series of sublime phenomena far surpassing what "eye hath yet seen," or the mind of man can yet conceive. Were we placed within this luminous atmosphere, on the solid surface of the sun, we should doubtless contemplate a scene altogether novel, and still more brilliant and astonishing. To a spectator in this position an opening in the luminous atmosphere several thousands of miles in circumference, where none appeared before, would be presented to his view, through which the stars of heaven might possibly be perceived: and in a short time this opening would gradually close, and he would find himself again surrounded with ineffable splendor; while, at the same time, he might have a view of the physical agents by which these astonishing effects are produced. In a short time another opening of a different kind would be perceived, and other scenes and transformations would be exhibited to the view in regular succession. That such scenes would actually be exhibited is a natural deduction from the theory (which may be considered as established) that the sun consists of a solid globe, surrounded with a luminous atmosphere, and that the dark spots are the openings in that luminous fluid.

It appears, then, that the sun which we daily behold is a body of ineffable magnitude and splendor, and that the most magnificent operations are incessantly going forward on its surface or in its immediate vicinity. It is, indeed, a kind of *universe* in itself, the magnitude, and extent, and grandeur of which, and the vast and sublime

operations connected with its physical constitution, surpass the powers of the human mind to form any adequate conception. We are destitute of a *substratum* of thought for enabling us to form a comprehensive conception on this subject. When we ascend to the top of Mount Etna or Mount Blanc, and survey the vast group of surrounding objects which appear around and beneath us when the morning sun illuminates the landscape, we behold one of the largest and most expansive objects that can meet our eye in this sublunary scene; and we can compare it with objects that are smaller and with those that are somewhat larger. But the amplitude of such a scene extends only to a hundred or a hundred and fifty miles in every direction, which is less than the least visible point or spot which we can perceive on the sun with the most powerful telescopes. Were we transported to a point five or six thousand miles above the surface of the earth, so as to take in nearly at one view the whole hemisphere of our globe; and were our eyes to be strengthened so as to be able to perceive every part of its surface distinctly, our ideas of *magnitude* would be vastly enlarged, and we should be enabled to form more correct and comprehensive conceptions than we can now do of the still greater magnitudes of many of the celestial bodies. But even such an object as the whole of the earth's hemisphere, seen at one comprehensive view, would afford us comparatively little assistance in forming an adequate conception of such a stupendous globe as the sun; it would not equal the idea of magnitude which we ought to attach to one of the smaller spots on its surface. For the area of the solar surface is twenty-four thousand seven hundred times greater; so that 24,700 scenes equal in magnitude to the hemisphere of our globe must pass between us in review before we could acquire a comprehensive and adequate idea of the expansive surface of the sun. And were a scene of this description to pass before our eyes every two hours, until an extent equal to the area of the sun passed under our view, and were twelve hours every day allotted for the observation, it would require more than eleven years before such a rapid survey of this vast luminary could be completed. But, as we can have no adequate idea of a scene comprehending a whole hemisphere of our globe, let us compare the view from Mount Etna with the amplitude of the sun. "There is no point on the surface of the globe," says Mr. Brydone, "that unites so many awful and sublime objects as the top of Etna, and no imagination has dared to form an idea of so glorious and magnificent a scene. The body of the sun is seen rising from the ocean, immense tracts both of sea and land intervening; the islands of Pinari, Alicudi, Lipari, Stromboli, and Volcano, with their smoking summits, appear under your feet, and you look down on the whole of Sicily as on a map, and can trace every river through all its windings from its source to its mouth. The view is absolutely boundless on every side, so that the sight is everywhere lost in the immensity." Yet this glorious and expansive prospect is comprised within a circle about 240 miles in diameter and 754 in circumference, containing 45,240 square miles, which is only 1-53,776,608th part of the surface of the sun; so that fifty-three millions, seven hundred and seventy-six thousand landscapes, such as beheld from Mount Etna, behoved to pass before us before we could contemplate a surface as expansive as that of the sun; and if every such landscape were to occupy two

hours in the contemplation, as supposed above, it would require *twenty-four thousand five hundred and fifty-four years* before the whole surface of this immense globe could be in this manner surveyed; and, after all, we should have but a very imperfect conception of the *solid contents* of the sun, which contains 356,818,739,209,090,000 of cubical miles, which number is 146,670 times greater than the number of square miles upon its surface.

What a glorious idea, then, does such an object as the sun present to us of the *GRANDEUR* of the Deity and the *ENERGIES* of OMNIPOTENCE! There is no single object within the range of our knowledge that affords a more striking and august emblem of its Great Creator. In its luster, in its magnitude, in its energy, in its boundless influence, and its beneficial effects on this earth and on surrounding worlds, there is a more bright display of Divine perfection than in any other material being with which we are acquainted:

"Great source of day! best image here below  
Of thy Creator! ever pouring wide  
From world to world, the vital ocean round,  
On Nature write, with every beam, his praise"

Could such a magnificent orb have been produced by a fortuitous concurrence of atoms, and placed in its proper position to distribute light and attractive influence to the worlds which roll around it? Could chance have directed the distance at which it should be placed from the respective planets, or the size to which it should be expanded, in order to diffuse its energies to the remotest part of the system? Could chance have impressed upon it the laws requisite for sustaining in their courses all the bodies dependent upon it, or have endowed it with a source of illumination which has been preserved in action from age to age? To affirm such positions would be to undermine and annihilate the principles of all our reasonings. The existence of the sun proves the existence of an Eternal and Supreme Divinity, and at the same time demonstrates his omnipotent power, his uncontrollable agency, the depths of his wisdom, and the riches of his beneficence. If such a luminary be so glorious and incomprehensible, what must its Great Creator be? If its splendor be so dazzling to our eyes, and its magnitude so overpowering to our imagination, what must He be who lighted up that magnificent orb, and bade a retinue of worlds revolve around it; who "dwells in light inaccessible, to which no mortal eye can approach?" If the sun is only one out of many myriads of similar globes dispersed throughout the illimitable tracts of creation, how great, how glorious, how far surpassing human comprehension must be the plans and the attributes of the infinite and eternal Creator! "His greatness is unsearchable, and his ways past finding out." Could we thoroughly comprehend the depths of his perfections or the grandeur of his empire, he would cease to be God, or we should cease to be limited and dependent beings. But, in presenting to our view such magnificent objects, it is evidently his intention that we should rise in our contemplations from the effect to the cause, from the creature to the Creator, from the visible splendors and magnificence of creation to the invisible glories of Him who sits on the throne of the universe, "whose kingdom ruleth over all, and before whom all nations are counted as less than nothing and vanity."

It might here form a subject of inquiry, *whether there be any reason to believe that the sun is inhab-*

*ited?* Most astronomers have been disposed to answer this question in the negative. Sir W. Herschel, however, and several others, consider it as not altogether improbable that the sun is peopled with rational beings. Viewing this luminary as consisting of a dark solid nucleus, surrounded by two strata of clouds, the outermost the region of that light and heat which is diffused to the remotest parts of the system, they conceived that the interior stratum was intended to protect the inhabitants of the sun from the fiery blaze of the sphere of light and heat with which they are surrounded. On either side of this question it becomes us to speak with diffidence and modesty. We ought not to set limits to the wisdom and arrangements of the Creator by affirming that rational beings could not exist and find enjoyment on such a globe as the sun, on account of the intensity of light and heat which forever prevails in that region. For it is probable that the luminous matter that encompasses the solid globe of the sun does not derive its splendor from any intensity of heat. If this were the case, the parts underneath, which are perpetually in contact with that glowing matter, would be heated to such a degree as to become luminous and bright, whereas we find that they have uniformly a *dark* appearance: so that it is possible the interior region of the sun may be in a state of comparatively low temperature. For anything we know to the contrary or can demonstrate, the sun may be one of the most splendid and delightful regions of the universe, and scenes of magnificence and grandeur may be there displayed far surpassing anything that is to be found in the planets which revolve around it, and its population may as far exceed in number that of other worlds as the immense size of this globe exceeds that of all the other bodies in the system. But, on the other hand, we know too little of the nature and constitution of the sun, and the plans of Divine Wisdom, to warrant us to make any positive assertions on this point. Although no intelligent beings were connected with this great luminary, its boundless influence in the planetary system; its being the soul and center of surrounding worlds; its diffusing light, and heat, and genial influences of various kinds, to all the tribes of their inhabitants; and its cementing them all by its attractive energy in one harmonious system, are reasons sufficient for the creation of this vast globe, without the influence of which perpetual darkness would ensue, the planets would start from their spheres, and the whole system soon become one universal wreck.

It is owing to the existence of the sun that our globe is a habitable world and productive of enjoyment. Almost all the benign agencies which are going forward in the atmosphere, the waters, and the earth, derive their origin from its powerful and perpetual influence. Its light diffuses itself over every region, and produces all that diversity of coloring which enlivens and adorns the landscape of the world, without which we should be unable to distinguish one object from another. By its vivifying action, vegetables are elaborated from inorganic matter, the sap ascends through their myriads of vessels, the flowers glow with the richest hues, the fruits of autumn are matured, and become, in their turn, the support of animals and of man. By its heat the waters of the rivers and the ocean are attenuated and carried to the higher regions of the atmosphere, where they circulate in the form of vapor until they again descend in showers, to supply the sources of the rivers and to fertilize the soil. By the same

agency all winds are produced, which purify the atmosphere by keeping it in perpetual motion, which propel our ships across the ocean, dispel noxious vapors, prevent pestilential effluvia, and rid our habitations of a thousand nuisances. By its attractive energy the tides of the ocean are modified and regulated, the earth conducted in its annual course, and the moon sustained and directed in her motions. Its influence descends even to the mineral kingdom, and is felt in the chemical compositions and decompositions of the elements of nature. The disturbances in the electric equilibrium of the atmosphere, which produce the phenomena of thunder, lightning, and rain, and the varieties of terrestrial magnetism; the slow degradation of the solid constituents of the globe and their diffusion among the waters of the ocean, may all be traced, either directly or indirectly, to the agency of the sun. It illuminates and cheers all the inhabitants of the earth from the polar regions to the torrid zone. When its rays gild the eastern horizon after the darkness of the night, something like a new creation appears. The landscape is adorned with a thousand shades and colors; millions of insects awake and bask in its rays; the birds start from their slumbers, and fill the groves with their melody; the flocks and herds express their joy in hoarse acclamations; "man goeth forth to his work and to his labor;" all nature smiles, and "the hills rejoice on every side." Without the influence of this august luminary, a universal gloom would ensue, and surrounding worlds, with all their trains of satellites, would be shrouded in perpetual darkness. This earth would become a lifeless mass, a dreary waste, a rude lump of inactive matter, without beauty or order. No longer should we behold the meadows clothed with verdure, the flowers shedding their perfumes, or "the valleys covered with corn." The feathered songsters would no longer chant their melodious notes; all human activity would cease; universal silence would reign undisturbed, and this huge globe of land and water would return to its original chaos.

Hence it appears that there is a sufficient reason for the creation of this powerful luminary, although no sensitive or intelligent beings of any description were placed on its surface. But, at the same time, when we consider the infinite wisdom and intelligence of the Divine mind, and that the thoughts and the ways of God as far surpass the thoughts of man as the heavens in height surpass the earth; when we consider that animated beings on our own globe are found in situations where we should never have expected them; that every puddle and marsh, and almost every drop of water, is crowded with living beings; and that even the very viscera in the larger animals can afford accommodation for sentient existence, it would be presumptuous in man to affirm that the Creator has not placed innumerable orders of sentient and intelligent beings, with senses and constitutions accommodated to their situations, throughout the expansive regions of the sun.

It has been a question which has exercised the attention of some astronomers, whether the solar phenomena have any effect upon the weather, or the productiveness of our seasons. Sir W. Herschel was of opinion, that when the corrugations and openings of the solar atmosphere are numerous, the heat emitted by the sun must be proportionably increased, and that this augmentation must be perceptible by its effects on vegetation; and, by comparing the solar appearances as given by La Lande with the table of the price of wheat in Smith's "Wealth of Nations," he obtained results

which he considered as favorable to his hypothesis. But it is evident that we are not yet in possession of such a series of facts in relation to this subject as will warrant us to draw any general conclusions. Beside, we know too little of the construction of the sun, and the nature of those processes which are going on in its atmosphere, to be able to determine the proportion of light and heat which particular phenomena indicate. So far as my own observation goes, I should be disposed to adopt an opposite conclusion, namely, that in those years when the spots of the sun are numerous, the seasons are colder and more unproductive of vegetation. This was remarkably the case in the year 1816, when the solar spots were extremely numerous, and when the harvest was so late and scanty, that the price of all kinds of grain was more than double what it had been before or what it has been since. The year 1836, and the present year, 1857, afford similar examples; for, during eighteen months past, the solar spots have been more numerous than in any other period in my recollection; and the cold of the summer and harvest of 1836, and of the winter and spring of 1837, and its unfavorable effects on vegetation, were greater than what had been experienced for more than twenty years before. But on this point we are not yet warranted to draw any positive conclusions. Before we can trace any general connection between the solar spots and the temperature and vegetation of our globe in any particular season, we must endeavor to ascertain the effects produced on vegetation not only in two or three particular countries which lie adjacent to each other, but over all the regions of the earth. It may be proper to direct our future observations to this point, as they might probably lead to some important results; but a considerable period behooved to elapse before we could be warranted to deduce any definite conclusions.

Whether the sun has a progressive motion in absolute space is another question which has engaged the attention of astronomers. If the sun have such a motion directed to any quarter of the heavens, the stars in that quarter must apparently recede from each other, while those in the opposite region will seem gradually to approach. Sir W. Herschel found that the apparent proper motion of forty-four stars out of fifty-six are very nearly in the direction which should result from a motion of the sun toward the constellation *Hercules*, or to a point of the heavens whose right ascension is  $250^{\circ} 52'$ , and north declination  $49^{\circ} 38'$ . "No one," says Sir John Herschel, "who reflects with due attention on the subject, will be inclined to deny the high probability, nay, *certainty*, that the sun has a proper motion in some direction." But it appears to be yet undetermined by modern astronomers to what point in the heavens this motion is directed, and whether it be in a straight line or in a portion of the circumference of an immense circle. If the sun, then, has a proper motion in space, all the planetary bodies and their satellites, along with the comets, must partake of it; so that, beside their own proper motions around this luminary, they are likewise carried along with the sun through the depths of infinite space with a velocity perhaps as great as that with which they are carried round in their orbits. Our earth will therefore partake of three motions: one round its axis, another round the sun, and a third in the direction in which the sun is moving, and, consequently, it is probable that we shall never again occupy that portion of absolute space through which we are



now passing throughout all the succeeding periods of eternity.

*The Zodiacal Light.*—The zodiacal light is a phenomenon which has been generally considered as connected with the sun. The light appears to have been noticed by Mr. Childrey about the year 1660; but it was afterward more particularly noticed and described by Cassini in the spring of 1683, which was the first time he had seen it, and he observed it for about eight days. It appears generally in a conical form, having its base directed toward the body of the sun and its point toward some star in the zodiac. Its light is like the milky way, or that of the faint twilight, or the tail of a comet, thin enough to let the stars be seen through it, and seems to surround the sun in the form of a lens, the plane of which is nearly coincident with the plane of the sun's equator.—The apparent angular distance of its vertex from the sun varies from 40 to 90 degrees, and the breadth of its base, perpendicular to its axis, from 8 to 30 degrees. It is supposed to extend beyond the orbit of Mercury, and even as far as that of Venus, but never so far as the orbit of the earth. This light is weaker in the morning when day is coming on than at night when darkness is increasing, and it disappears in full moonlight or in strong twilight. In north latitudes it is most conspicuous after the evening twilight about the end of February and the beginning of March; and before the appearing of the morning twilight, about the beginning of October; for at those times it stands most erect above the horizon, and is therefore farthest removed from the thick vapors and the twilight. About the time of the winter solstice it may likewise be seen in the mornings; but it is seldom perceptible in summer on account of the long twilights. It is more easily and more frequently perceived in tropical climates, and particularly near the equator, than in our country, because in those parts the obliquity of the equator and zodiac to the horizon is less, and because the duration of twilight is much shorter. Humboldt observed this light at Caracas, on the 18th of January, after seven o'clock in the evening. The point of the pyramid was at the height of 53 degrees; and the light totally disappeared about half past nine, about 3 $\frac{1}{4}$  hours after sunset, without any diminution in the serenity of the sky. On the 15th of February it disappeared 2 hours and 50 minutes after sunset, and the altitude of the pyramid on both these occasions was

50 degrees. The following figure exhibits a view of this phenomenon as it is seen about the beginning of March, at seven o'clock in the evening,

Fig. 77.

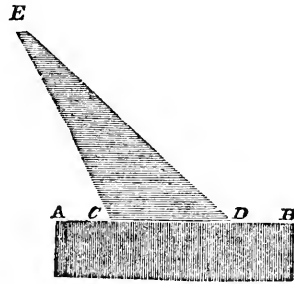

when the twilight is ending, and the equinoctial point in the horizon. *AB* represents the horizon; *CD* the base of the luminous triangle; and *E* its apex, pointing toward the Pleiades or the star Aldebaran, its axis forming an angle of between 60 and 70 degrees with the horizon.

Various opinions have been entertained as to the cause of this phenomenon; but as it uniformly accompanies the sun, it has been generally ascribed to an atmosphere of immense extent surrounding that luminary, and extending beyond the orbit of Mercury. According to this opinion, the zodiacal light is considered as a section of this atmosphere; but this opinion now appears extremely dubious. Professor Olmsted, of Yale College, the celebrated Arago, Biot, and others, are now disposed to identify this phenomenon with the cause that produces the "November Meteors," or shooting stars, which have, of late, excited so great a degree of public attention. It appears highly probable that these meteors derive their origin from a nebulous body which revolves round the sun, and which, in certain parts of its course, comes very near the orbit of the earth, so as to be within its attractive power; and if such a body be the source whence these meteors proceed, it may also account for the phenomena of the zodiacal light. The subject is worthy of particular attention, and future observations may not only throw light on this particular phenomenon, but open to our view a species of celestial bodies with which we were formerly unacquainted.

## CHAPTER IV.

### ON THE SECONDARY PLANETS OR MOONS.

HAVING, in the preceding chapter, given a detailed account of the phenomena connected with the sun and the primary planets of our system, I shall now proceed to a brief description of what is known in reference to the satellites or moons which accompany several of the primary planets.

A secondary planet or satellite is a body which revolves around a primary planet as the center of its motion, and which is at the same time carried along with its primary round the sun. The satellites form a system, in connection with their primaries, similar to that which the planets form in

connection with the sun. They revolve at different distances from their primaries; they are regulated according to the laws of Kepler formerly alluded to; their orbits are circles or ellipses of very moderate eccentricity; in their motions around their primaries they describe areas very nearly proportional to the times; and the squares of the periodical times of all the satellites belonging to each planet are in proportion to each other as the cubes of their distances (see page 23). The planets around which satellites have been discovered, are, the earth, Jupiter, Saturn, and

Uranus. Of the satellites belonging to these bodies I shall present a brief sketch in the order in which they are here mentioned.

#### I. OF THE EARTH'S SATELLITE, OR THE MOON.

Before proceeding to a particular description of this nocturnal luminary, I shall present a brief sketch of its *apparent motions*.

The moon, like all the other celestial bodies, appears daily to rise in an easterly direction, and to set in the western parts of the horizon. Its apparent motion in this respect is similar to that of the sun, formerly described, and is owing to the diurnal motion of the earth. Its *real motion* round the earth is in a contrary direction, namely, from west to east, or in the same direction in which all the planets move round the sun. This motion may be traced every lunation, but more distinctly during the spring months, when the moon, in the first quarter, appears in a high degree of north declination, and when its crescent is sometimes visible within thirty-six hours of the change. About this period, on the second or third day of the moon's age, it will be seen in the west after sunset at a small elevation above the horizon, and exhibiting the form of a slender crescent. On the next evening it will appear at a still higher elevation at the same hour, having moved about thirty degrees farther to the east, and its crescent will appear somewhat larger. Every succeeding day it will appear at a greater elevation, and farther to the east than before, and its crescent will appear larger, until about the seventh or eighth day, when it will be seen in the south when the sun is setting in the west, at which time it assumes the appearance of a semicircle, or half moon. During this period the horns of the crescent point toward the east, the enlightened part of the lunar disc being turned toward the sun. After the first quarter, or the period of half moon, the lunar orb still keeps on its course to the eastward, and the portion of its enlightened disc is gradually enlarged, until about the fifteenth day of the moon's age, when it appears as a full enlightened hemisphere, and rises in the east about the time when the sun is setting in the west. In this position it is said to be in *opposition* to the sun, and passes the meridian about midnight. After this period the enlightened part of its disc gradually diminishes, and it rises at a later hour, until, in the course of seven days, it is again reduced to a semicircle, and is seen only during one half of the night. Some nights after it appears reduced to a crescent, having its points or horns turned toward the *west*, the sun being then to the east of it. After this it rises but a little time before the sun, and is seen only early in the morning; and its crescent daily diminishes until it at length disappears, when it rises at the same time with the sun; and after having been invisible for two or three days, it reappears in the evening in the west a little after sunset. During this period the moon has made a complete circuit round the heavens from west to east, which is accomplished in twenty-nine days and a half, in which period it passes through all the phases now described. The progressive motion from west to east, every day, may be traced by observing the stars which lie nearly in the line of the moon's course. If a star be observed considerably to the eastward of the moon on any particular evening, on the following evening it will appear about thirteen degrees nearer the star, and will afterward pass to the eastward of it, and every succeeding day will approach nearer to all the other stars which lie

near the line of its course to the eastward. The reason why the moon appears under the different phases now described will appear from the following figure.

In this diagram *S* represents the sun; *E* the earth; and *M, A, B, C, D, F, G, H*, the moon in different positions in its orbit round the earth. When the moon is at *M*, as seen from the earth, her dark side is completely turned to the earth; and she is consequently invisible, as at *I*, being

Fig. 78.

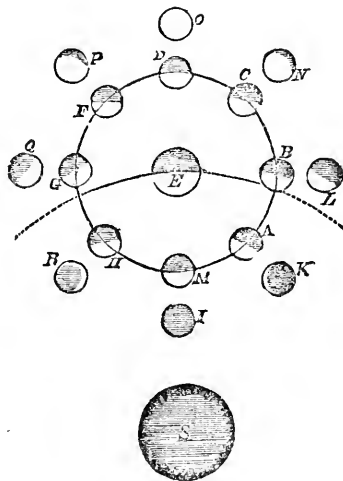

nearly in the same part of the heavens with the sun. She is in this position at the period termed *new moon*, when she is also said to be in *conjunction* with the sun. When she has moved from *M* to *A* a small part of her enlightened hemisphere is turned toward the earth, when she appears in the form of a *crescent*, as at *K*. In moving from *A* to *B* a larger portion of her enlightened hemisphere is gradually turned toward the earth; and when she arrives at *B* the one-half of her enlightened hemisphere is turned to the earth, and she assumes the figure of a *half moon*, as at *L*. When arrived at *C* she appears under what is called a *gibbous* phase, as at *N*, more than one-half of her enlightened disc being turned to the earth. At *D* her whole enlightened hemisphere is turned to our view, and she appears a *full moon*, as at *O*. After this period she again decreases, turning every day less and less of her enlightened hemisphere to the earth, so that at *F* she appears as at *P*; at *G* a half-moon on the *decline*, as at *Q*; at *H* a crescent, as at *R*; and at *M* she is again in conjunction with the sun, when her dark side is turned to the earth as before. The moon passes through all these changes in twenty-nine days, twelve hours, and forty-four minutes, at an average, which is termed her *synodical revolution*. But the time which she takes in making one revolution round the earth, from a fixed star to the same again, is only twenty-seven days, seven hours, and forty-three minutes, which is called her *periodical revolution*. For, after one revolution is finished, she has a small arc to describe in order to get between the sun and the earth; because, in consequence of the earth's motion in the same direction, the sun appears to be advancing forward in the ecliptic, and, of course, the moon requires some time to overtake him, after having finished a revolution. This surplus of motion occupies

two days, five hours, and one minute, which, added to the periodical, make the synodical revolution, or the period between one new or full moon and another. This might be illustrated by the revolution of the hour and minute-hands of a watch or clock. Suppose the hour-hand to represent the sun, and a complete revolution of it to represent a year; suppose the minute-hand to represent the moon, and its circuit round the dial-plate a month, it is evident that the moon or minute-hand must go more than round the circle where it was last conjoined with the sun or hour-hand before it can again overtake it. If, for example, they were in conjunction at 12, the minute-hand or moon must make a complete revolution and above one-twelfth before they can meet, a little past 1; for the hour-hand, being in motion, can never be overtaken by the minute-hand at that point from which they started at their last conjunction.

To a spectator placed on the lunar surface, the earth would every month exhibit all the phases of the moon, but in a reverse order from what the moon exhibits to the earth at the same time. Thus (Fig. 78), when the moon is at *D* only the dark hemisphere of the earth is turned toward the moon, and, consequently, the earth would be then invisible; so that when it is full moon to us, it is new moon to a lunar inhabitant; as the earth will then be in conjunction with the sun, and nothing but its dark hemisphere presented to view. When the moon is at *P* a small portion of the enlightened half of the earth is turned toward the moon, and it appears as a crescent. When she is at *Q* the earth appears as a half-moon; when at *R*, a gibbous phase; and when she is at *I*, the time of new moon to us, the earth then shines on the dark side of the moon with a full enlightened hemisphere. It is owing to this circumstance, that when the new moon first appears like a slender crescent, her dark hemisphere is seen illuminated with a faint light, perceptible even to the naked eye; and with the help of a telescope we are enabled, by this faint illumination, to distinguish the prominent spots on this portion of the lunar disc. This faint light, therefore, is nothing else than the *moonlight of the moon*, produced by the earth shining with nearly a full face upon the dark surface of the moon. And as the surface of the earth is thirteen times larger than the surface of the moon, the light reflected from the earth will be nearly equal to that of thirteen full moons. As the age of the moon increases, this secondary light is gradually enfeebled, and after the seventh or eighth day from the change it is seldom visible. This arises from the diminution of the enlightened part of the earth, which then appears only like a half-moon, approaching to a crescent, and consequently, throws a more feeble light upon the moon, which is the more difficult to be perceived as the enlightened part of the moon increases.

*Rotation of the Moon.*—While the moon is performing her revolution round the earth every month, she is also gradually revolving round her axis; and it is somewhat remarkable that her revolution round her own axis is performed in the same time as her revolution round the earth. This is inferred from the circumstance that the moon *always turns the same face to the earth*, so that we never see the other hemisphere of this globe. For if the moon had no rotation upon an axis, she would present every part of her surface to the earth. This does not, at first sight, appear obvious to those who have never directed their attention to the subject. Any one, however, may convince himself of the fact by standing in the center of a

circle, and causing another person to carry round a terrestrial globe, without turning it on its axis, when he will see every part of the surface of the globe in succession; and in order that one hemisphere only should be presented to his view, he will find that the globe will require to be gradually turned round its axis, so as to make a complete rotation during the time it is carried round the circle. The axis of the moon is inclined  $88^{\circ} 29'$  to the ecliptic, so that it is nearly perpendicular to it. Although the moon presents nearly the same side to the earth in all its revolutions around it, yet there is perceived a certain slight variation in this respect. When we look attentively at the disc of the moon with a telescope, we sometimes observe the spots on her eastern limb, which were formerly visible concealed behind her disc, while others appear on her western limb which were not seen before. The spots which appear on the western limb withdraw themselves behind the limb, while the spots which were concealed behind the eastern limb again appear. The same phenomena are observed in the north and south limb of the moon, so that the spots sometimes change their positions about three minutes on the moon's disc, or about the eleventh part of her diameter. This is termed the *libration of the moon*; the one her libration in *longitude*, and the other her libration in *latitude*.

From what we have stated above in relation to the phases and motions of the moon, it is evident that the moon is a dark body, like the earth, and derives all its light from the sun, for its enlightened side is always turned toward that luminary. It likewise derives a faint light by the reflection of the sun's rays from the earth, in the same way as we derive a mild light from the moon. And as the earth has an uneven surface, composed of mountains and vales, so the moon is found to be diversified with similar inequalities. It is owing to these inequalities, or the *roughness* of the moon's surface, that the light of the sun is reflected from it in *every direction*; for, if the surface of the moon were perfectly smooth, like a polished globe or speculum, her orb would be invisible to us; except, perhaps, at certain times, when the image of the sun, reflected from it, would appear like a bright lucid point. This may be illustrated by the following experiment. Place a silver globe, perfectly polished, about two inches diameter, in the sun; the rays which fall upon it being reflected variously, according to their several incidences, upon the convex surface, will come to our eye only from one point of the globe, which will therefore appear a small bright spot, but the rest of the surface will appear dark. Let this globe then be boiled in the liquor used for whitening silver, and placed in the sun; it will appear in its full dimensions all over luminous; for the effect of that liquor is to take off the smoothness of the polish, and make the surface rough, and then every point of it will reflect the rays of light in every direction.

The moon is nearest to the earth of all the celestial bodies, and is a constant attendant upon it at all seasons. Her distance from the center of the earth is, in round numbers, 240,000 miles, or somewhat less than a quarter of a million; which is little more than the fourth part of the diameter of the sun. Small as this distance is compared with that of the other planets, it would require five hundred days, or sixteen months and a half, for a steam-carriage to move over the interval which separates us from the lunar orb, although it were moving day and night at the rate of twenty miles every hour. In her motion round the earth

every month, she pursues her course at the rate of 2300 miles an hour. But she is carried at the same time, along with the earth, round the sun every year, so that her real motion in space is much more rapid than what has now been stated; or while she accompanies the earth in its motion round the sun, which is at the rate of 68,000 miles an hour, she also moves thirteen times round the earth during the same period, which is equal to a course of nearly twenty millions of miles.

The moon's orbit is inclined to the ecliptic in an angle of  $5^{\circ} 9'$ ; so that, in one part of her course, she is above, and in another below the level of the earth's orbit. It is owing to this circumstance that this orb is not eclipsed at every full moon and the sun at every new moon, which would regularly happen did the moon move in an orbit exactly coincident with the plane of the ecliptic. The moon's orbit, of course, crosses the orbit of the earth in two opposite points, called her *nodes*; and it is only when the new or full moon happens at or near these nodes that an eclipse of the sun or moon can take place; for it is only when she is in such a position that the sun, the moon, and the earth are nearly in a straight line, and that the shadow of the one can fall upon the other. The shadow of the moon falling upon any part of the earth produces an eclipse of the sun, and the shadow of the earth falling upon the moon causes an eclipse of the moon. An eclipse of the moon can only take place at *full moon*, when the earth is between the

eclipse is never seen throughout the whole hemisphere of the earth where the sun is visible; as the moon's disc is too small to hide the whole, or any part of the sun from the whole disc or hemisphere of the earth. Nor does an eclipse of the sun appear the same in all parts of the earth where it is visible, but when in one place it is total, in another it is only partial.

The moon's orbit, like those of the other planets, is in the form of an *ellipse*, the *eccentricity* of which is 12,969 miles, or about 1-37th part of its longest diameter. The moon is, therefore, at different distances from the earth in different parts of her orbit. When at the greatest distance from the earth, she is said to be in her *apogee*; when at the least distance, in her *perigee*. The nearer the moon is to the periods of *full* or *change*, the greater is her velocity; and the nearer to the quadratures, or the periods of half-moon, the slower she moves. When the earth is in its *perihelion*, or nearest the sun, the periodical time of the moon is the greatest. The earth is at its perihelion in winter, and, consequently, at that time the moon will describe the largest circle about the earth, and her periodical time will be the longest; but when the earth is in its *aphelion*, or farthest from the sun, which happens in summer, she will describe a smaller circle, and her periodical time will be the least; all which circumstances are found to agree with observation. These and many other irregularities in the motion of this orb, which it would be too tedious to particularize, arise from the attractive influence of the sun upon the lunar orb in different circumstances and in different parts of its course, so as to produce different degrees of accelerated and retarded motion. The irregularities of the moon's motion have frequently puzzled astronomers and mathematicians, and they render the calculations of her true place in the heavens a work of considerable labor. No less than thirty equations require to be applied to the *mean* longitude in order to obtain the *true*, and about twenty-four equations for her latitude and parallax; but to enter minutely into such particulars would afford little satisfaction to general readers.

*Description of the surface of the Moon, as seen through telescopes.*—Of all the celestial bodies, the telescopic view of the moon presents the most interesting and variegated appearance. We perceive, as it were, a map or model of another world, resembling in some of its prominent features the world in which we dwell, but differing from it in many of its minute arrangements. It bears a certain analogy to the earth in some of the mountains and vales which diversify its surface; but the general form and arrangement of these elevations and depressions, and the scenery they present to the spectator on the lunar surface, are very different from what we behold in our terrestrial landscapes. When we view the moon with a good telescope when about three days old, we perceive a number of elliptical spots with slight shadows, evidently indicating elevations and depressions; we also perceive a number of bright specks or studs in the dark hemisphere, immediately adjacent to the enlightened crescent, and the boundary between the dark and the enlightened portion of the disc appears jagged and uneven. At this time, too, we perceive the dark part of the moon covered with a faint light; so that the whole circular outline of the lunar hemisphere may be plainly discerned. When we take a view of the lunar surface, at the period of half moon, we behold a greater variety of objects, and the shadows of the mountains and caverns appear larger and more prominent. This is, on the

Fig. 79.

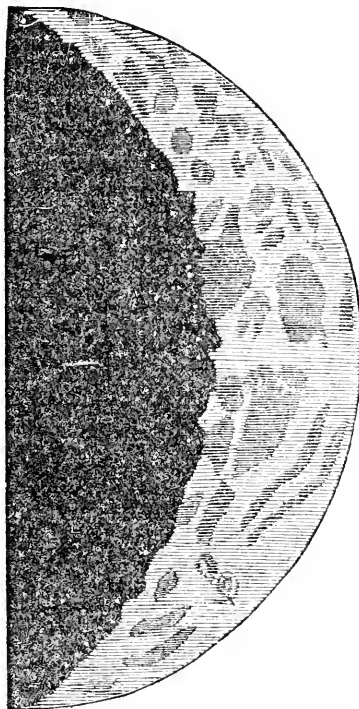

sun and the moon; and an eclipse of the sun can only happen at *new moon*, when the moon comes between the sun and the earth. Lunar eclipses are visible in all parts of the earth which have the moon above their horizon, and are everywhere of the same magnitude and duration; but a solar

whole, the best time for taking a telescopic view of the surface of the moon. When we view her when advanced to a gibbous phase we see a still greater extent of the surface, but the shadows of the different objects are shorter and less distinct. At the time of full moon, no shadows either of the mountains or caverns are perceptible, but a variety of dark and bright streaks and patches appear distributed in different shapes over all its surface. If we had no other view of the moon but at this period, we should scarcely be able to determine whether mountains and vales existed on this orb. The view of the full moon, therefore, however beautiful and variegated, can give us no accurate idea of the mountains, vales, caverns, and other geographical arrangements which diversify its surface.

*Lunar Mountains.*—That the surface of the moon is diversified with mountains or high elevations, is evident from an inspection of its disc, even with a common telescope. They are recognized from various circumstances. 1. From the appearance of the boundary which separates the dark from the enlightened hemisphere of the moon. This boundary is not a straight line or a regular curve, as it would be if the moon were a perfectly smooth globe, but uniformly presents an uneven or jagged appearance, cut, as it were, into numerous notches and breaks somewhat resembling the teeth of a saw, which appearance can only be produced by elevations and depressions on the lunar surface (Fig. 79). 2. Adjacent to the boundary between light and darkness, and *within* the dark part of the moon, there are seen, in almost every stage of the moon's increase and decrease, a number of *shining points* like stars, completely separated from the enlightened parts, and sometimes other small spaces or streaks which join to the enlightened surface, but run out into the dark side, which gradually change their figure until at length they come wholly within the enlightened boundary. These shining points or streaks are ascertained to be the tops or highest ridges of mountains which the sun first enlightens before his rays can reach the valleys; just as the beams of the rising sun irradiate our mountain tops before the lower parts of the landscape are enlightened. 3. The *shadows* of the mountains, when they are fully enlightened, are distinctly seen near the border of the illuminated part of the moon, as the shadows of elevated objects are seen on the terrestrial landscape. These shadows are longest and most distinctly marked about the time of half-moon; and they grow shorter as the lunar orb advances to the period of full moon, in the same way as the shadows of terrestrial objects in summer gradually shorten as the sun approaches the meridian. These considerations demonstrate, beyond the possibility of doubt, that mountains of very considerable altitude and in vast variety of forms abound in almost every region of the moon.

The lunar mountains in general exhibit an arrangement and an aspect very different from the mountain scenery of our globe. They may be arranged into the four following varieties: 1. *Insulated mountains*, which rise from plains nearly level, like a sugar-loaf placed on a table, and which may be supposed to present an appearance somewhat similar to Mount Etna or the peak of Teneriffe. The shadows of these mountains, in certain phases of the moon, are as distinctly perceived as the shadow of an upright staff when placed opposite to the sun; and their heights can be calculated from the length of their shadows. The heights and the length of the base of more

than seventy of these mountains have been calculated by M Schroeter, who had long surveyed the lunar face with powerful telescopes, and who some time ago published the result of his observations in a work entitled "Fragments of Selenography." Thirty of these insulated mountains are from 2 to 5 miles in perpendicular height; thirteen are above 4 miles; and about forty are from a quarter of a mile to two miles in altitude. The length of their bases varies from  $3\frac{1}{2}$  to 96 miles in extent. Some of these mountains will present a very grand and picturesque prospect around the plains on which they stand. 2. *Ranges of mountains*, extending in length two or three hundred miles. These ranges bear a distant resemblance to our Alps, Apennines, and Andes, but they are much less in extent, and do not form a very prominent feature of the lunar surface. Some of them appear very rugged and precipitous, and the highest ranges are, in some places, above four miles in perpendicular altitude. In some instances they run nearly in a straight line from north-east to south-west, as in that range called the *Apennines*; in other cases they assume the form of a semicircle or a crescent. 3. Another class of the lunar mountains is the *circular ranges* which appear on almost every part of the moon's surface, particularly in its southern regions. This is one

Fig. 80.

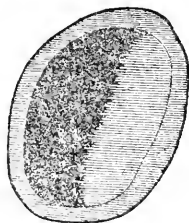
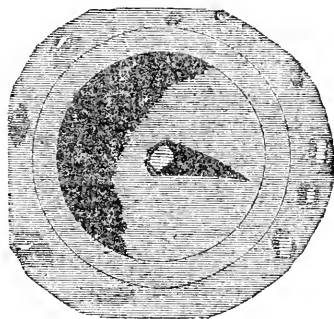

Fig. 81.



of the grand peculiarities of the lunar ranges, to which we have nothing similar in our terrestrial arrangements. A plain, and sometimes a large cavity, is surrounded with a circular ridge of mountains, which encompasses it like a mighty rampart. These annular ridges and plains are of all dimensions, from a mile to forty or fifty miles in diameter, and are to be seen in great numbers over every region of the moon's surface. The mountains which form these ridges are of different elevations, from one-fifth of a mile to  $3\frac{1}{2}$  miles in altitude, and their shadows sometimes cover the one-half of the plain.

These plains are sometimes on a level with the general surface of the moon, and in other cases they are sunk a mile or more below the level of the

Fig. 82.

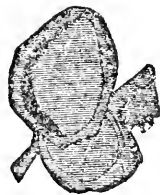

ground which surrounds the *exterior* circle of the mountains. In some of these circular ridges I have perceived a narrow *pass* or opening, as if intended to form an easy *passage* or communication between the interior plain and the regions beyond the exterior of the mountains. 4. The next variety is the *central mountains*, or those which are placed in the middle of circular plains. In many of the plains and cavities surrounded by annular mountains there is an insulated mountain, which rises from the center of the plain, and whose shadow sometimes extends, in a pyramidal form, across the semi-diameter of the plain to the opposite ridges. These central mountains are generally from half a mile to a mile and a half in perpendicular altitude. In some instances they have two and sometimes three separate tops, whose distinct shadows can be easily distinguished. Sometimes they are situated toward one side of the plain or cavity, but, in the great majority of instances, their position is nearly or exactly central. The lengths of their bases vary from five to about fifteen or sixteen miles.

The preceding figures may perhaps convey a rude idea of some of the objects now described; but

Fig. 83.

North.

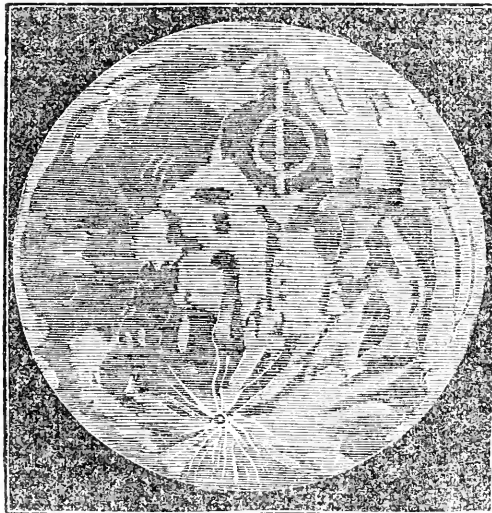

it is impossible, by any delineations, to convey an idea of the peculiarities and the vast variety of scenery which the lunar surface presents, such as is exhibited by a powerful telescope during the different stages of the increase and decrease of the moon.

Fig. 79 represents the moon in a crescent phase, for the purpose of showing how the enlightened tops of the mountains appear on the dark part of the moon, detached as it were from the enlightened part, and likewise to show how the boundary between the light and darkness appears jagged and uneven, indicating the existence of elevations and depressions upon its surface. Fig. 80 represents a circular or elliptical range of mountains, surrounding a plain of the same shape, where the shadow of that side of the range which is opposite to the sun appears covering the half of the plain. Fig. 81 represents a circular plain, with the shadow of one side of the mountains which encompass it, and a *central* mountain with its shadow

in the same direction. Fig. 82 exhibits another of these circular ridges and plains. Several hundreds of these circular cavities and plains are distributed over the lunar surface, but they are most abundant in the southern regions.

Fig. 83 exhibits a pretty correct view of the full moon, as seen through a telescope magnifying above a hundred times, in which the darker shades represent, for the most part, the *level* portions of the moon's surface, and the lighter shades those which are more elevated or mountainous. The bright spot near the bottom, from which streaks or streams of light seem to proceed, is called *Tycho* by some, and *Mount Etna* by others. It consists of a large irregular cavity, surrounded by mountains; and the streaks of light are the elevated ridges of ranges of mountains, which seem to converge toward it as to a center. This is the most variegated and mountainous region of the lunar surface. Fig. 84 is a view of the moon, hastily taken, when in a gibbous phase. The shadows were then comparatively short, and it would require to be engraved on a much more extensive scale than our page admits to show distinctly the elevations and depressions at the boundary between light and darkness. Fig. 85 (Nos. 1 and 2) represent some detached spots near the line which separated the dark and enlightened parts of the moon.

From what has now been stated respecting the lunar mountains, it will evidently appear that there must be a great variety of sublime and picturesque scenery connected with the various landscapes of the moon. If the surface of that orb be adorned with a diversity of color and with something analogous to the vegetation of our globe, there must be presented to the view of a spectator in the moon a variety of scenes altogether dissimilar to those which we can contemplate on this earth. The circular plains and mountains will present three or four varieties of prospect, of which we have no examples on our globe. In the first place, a spectator near the middle of the plane will behold his view bounded on every hand by a chain of lofty mountains, at the distance of 5, 10, 15, or 20 miles, according to the diameter of the plain; and as the tops of these mountains are at different elevations, they will exhibit a *variety* of mountain-scenery. In the next place, when standing on the top of the central mountain, the whole plain, with its diversified objects, will be open to his view, which will likewise take in all the variety of objects connected with the circular mountain-range which bounds his prospect. A third variety of view will be presented in traveling round the plain, where the various aspects of the central mountain will present, at every stage, a new landscape and a diversity of prospect. Another view, still more extensive, will be obtained by ascending to the summit of the circular range, where the whole plain and its central mountain will be full in view, and a prospect will, at the same time, be opened of a portion of those regions which lie beyond the *exterior* boundary of the mountains (see Fig. 81). A diversity of scenery will likewise be presented by the *shadows* of the circular range and the central mountain. When the sun is in the horizon, the whole plain will be enveloped in the shadows of the mountains, even after daylight begins to appear. These shadows will grow shorter and shorter as the sun rises in the heavens; but a space of time equal to one or two of our days

will intervene before the body of the sun is seen from the opposite side of the plain, rising above the mountain tops; and a still longer space of time before his direct rays are seen at the opposite extremity. These shadows are continually varying; during the increase of the moon they are thrown in one direction, and during the decrease in a direction exactly opposite; and it is only about the time of full moon that every part of the plain, and the mountains which surround it, are fully enlightened, and the shadows disappear. There must, therefore, be a far greater variety of sublime mountain-scenery, and of picturesque objects connected with it, on the lunar surface, than what is presented to our view in terrestrial landscapes.

*The Lunar Cavities.*—These form a very peculiar and prominent feature of the moon's surface, and are to be seen throughout almost every region; but are most numerous in the south-west part of the moon. Nearly a hundred of them, great and small, may be distinguished in that quarter. They are all nearly of a circular shape, and appear like a very shallow egg-cup. The smaller cavities appear within almost like a hollow cone, with the sides tapering toward the center; but the larger ones have, for the most part, flat bottoms, from the center of which there frequently rises a small steep conical hill, which gives them a resemblance to the annular ridges and central mountains above described. In some instances their margins are level with the general surface of the moon, but in most cases they are encircled with a high annular ridge of mountains marked by lofty peaks. Some of the larger of these cavities contain smaller cavities of the same kind and form, particularly in their sides. The mountainous ridges which surround these cavities reflect the greatest quantity of light; and hence that region of the moon in which they abound appears brighter than any other. From their lying in every possible direction, they appear, at and near the time of full moon, like a number of brilliant streaks or radiations. These radiations appear to converge toward a large brilliant spot surrounded by a faint shade, near the lower part of the moon, which is known by the name of *Tycho*, and which every one who views the full moon, even with a common telescope, may easily distinguish. In regard to their *dimensions*, they are of all sizes, from three miles to fifty miles in diameter at the top; and their depth below the general level of the lunar surface varies from one-third of a mile to three miles and a half. Twelve of these cavities, as measured by Schroeter, were found to be above two miles in perpendicular depth. These cavities constitute a *peculiar feature* in the scenery of the moon, and her physical constitution, which bears scarcely any analogy to what we observe in the physical arrangements of our globe. But, however different such arrangements may appear from what we see around us in the landscapes of the earth, and however unlikely it may at first sight appear that such places should be the abode of intelligent beings, I have no doubt that, in point of beauty variety, and sublimity, these spacious hollows, with all their assemblage of circular and central mountain-scenery, will exceed in interest and grandeur any individual scene we can contemplate on our globe. We have only to conceive

that such places are diversified and adorned with all the vegetable scenery which we reckon beauti-

Fig. 84.

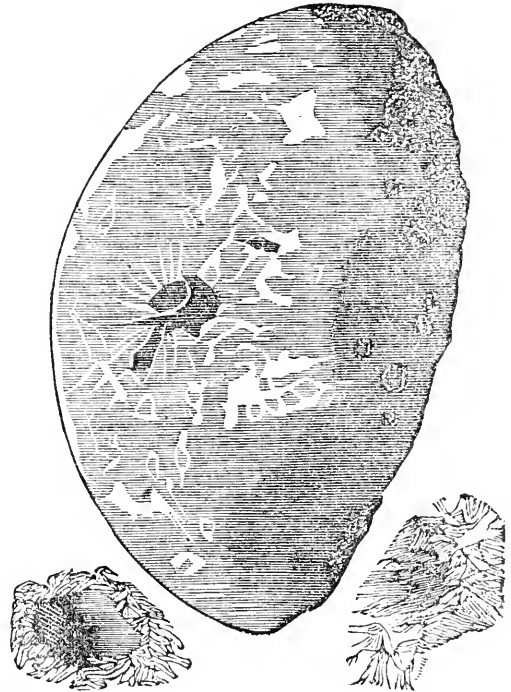

Fig. 85. (No. 1.)

Fig. 85. (No. 2.)

ful and picturesque in a terrestrial landscape, and with objects which are calculated to reflect with brilliancy the solar rays, in order to give such an idea of the grandeur of the scene. And that the objects connected with these hollows are formed of substances fitted to reflect the rays of the sun with peculiar luster, appears from the brilliancy which most of them exhibit when either partially or wholly enlightened; presenting to view, especially at full moon, the most luminous portions of the lunar surface, so that former astronomers were led to compare them to rocks of diamond.

*Whether there be any evidence of Volcanoes in the Moon.*—From a consideration of the broken and irregular ground, and the deep caverns which appear in different parts of the moon's surface, several astronomers were led to conjecture that such irregularities were of volcanic origin. These conjectures were supposed to be confirmed by the appearance of certain luminous points, which were occasionally seen on the dark part of the moon. During the annular eclipse of the sun on the 21th of June, 1778, Don Ulloa perceived, near the north-west limb of the moon, a bright white spot, which he imagined to be the light of the sun shining through an opening in the moon. This phenomenon continued about a minute and a quarter, and was noticed by three different observers. Beccaria observed a similar spot in 1772. M. Bode, of Berlin, M. de Villeneuve, M. Nouet, Captain Kater, and several others, at different times observed similar phenomena, some of which had the appearance of a small nebula, or a star of the sixth magnitude, upon the dark part of the

lunar disc. Sir W. Herschel, in 1787, observed similar phenomena, which he ascribes to the eruption of volcanoes. The following is an extract from his account of those phenomena: "April 19, 1787, 10*h*. 36*m*. I perceive three volcanoes in different places of the dark part of the new moon. Two of them are already nearly extinct, or otherwise in a state of going to break out; the third shows an eruption of fire or luminous matter. The distance of the crater from the northern limb of the moon is 3' 57"; its light is much brighter than the nucleus of the comet which M. Mechain discovered at Paris on the 10th of this month." "April 20, 10*h*. The volcano burns with greater violence than last night; its diameter cannot be less than three seconds; and hence the shining or burning matter must be above three miles in diameter. The appearance resembles a small piece of burning charcoal when it is covered by a very thin coat of white ashes, and it has a degree of brightness about as strong as that with which such a coal would be seen to glow in faint daylight."

Such are some of the phenomena from which it has been concluded that volcanoes exist in the moon. That such appearances indicate the existence of fire or some species of luminosity on the lunar surface, is readily admitted; but they by no means prove that anything similar to terrestrial volcanoes exist in that orb. We err egregiously when we suppose that the arrangements of other worlds must be similar to those on our globe, especially when we perceive the surface of the moon arranged in a manner so very different from that of the earth. We have no right to conclude that burning mountains abound in the moon because these are the only large streams of fire that occasionally burst forth from certain points on our globe. For there are many other causes of which we are ignorant, and which may be peculiar to the moon, which may produce the occasional gleams or illuminations to which we allude. The conflagration of a large forest, such as happened a few years ago at Miramichi, the blazing of large tracts of burning heath, the illumination of a large town, or the conflagration of such a city as Moscow, would, in all probability, present to a spectator in the moon luminous specks such as those which astronomers have observed on the dark portion of the lunar orb. Such luminosities in the moon may possibly be of a phosphoric nature, or a mere display of some brilliant artificial scenery by the inhabitants of that planet. Schroeter is of opinion that most of these appearances are to be ascribed to the light reflected from the earth to the dark part of the moon's disc, which returns it from the tops of the mountains under various angles, and with different degrees of brightness; and from various observations I have made on the dark portion of the moon, when about two or three days old, and from the degree of brightness with which some of the small spots have frequently appeared, I am disposed to consider this opinion as highly probable.

The existence of volcanoes on our globe is scarcely to be considered as a part of its original constitution. Such appalling and destructive agents appear altogether inconsistent with the state of an innocent being formed after the Divine image; and, therefore, we have no reason to believe that they existed in the primitive age of the world, while man remained in his paradisaical state, but began to operate only after the period of the universal deluge, when the primitive constitution of our globe was altered and deranged, and when earthquakes, storms, and tempests began, at the same time, to exert their destructive energies.

They are thus to be considered as an evidence or indication that man is no longer in a state of moral perfection and that his habitation now corresponds with his character as a sinner. To suppose, therefore, that such destructive agents exist in the moon, would be virtually to admit that the inhabitants of that planet are in the same depraved condition as the inhabitants of this world. The same thing may be said with regard to a pretended discovery which was announced some years ago, that "there are fortifications in the moon;" for, if such objects really existed, it would be a plain proof that the inhabitants were engaged in wars and contentions, and animated with the same diabolical principles of pride, ambition, and revenge, which have ravaged our globe and demoralized its inhabitants.

Whether there be Seas in the Moon is a question which has engaged the attention of astronomers, and which demands a few remarks. When we view the moon through a good telescope, we perceive a number of large dark spots, of different dimensions, some of which are visible to the naked eye. These spots, in the early observations of the moon with telescopes, were generally supposed to be large collections of water similar to our seas, and the names given them by Hevelius, such as *Mare Crisium*, *Mare Imbrium*, &c., are founded on this opinion. The general smoothness of these obscure regions, and the consideration that water reflects less light than the land, induced some astronomers to draw this conclusion. But there appears no solid ground for entertaining such an opinion; for, in the first place, when these dark spots are viewed with good telescopes, they are found to contain numbers of cavities, whose shadows are distinctly perceived falling within them, which can never happen in a sea or smooth liquid body; and beside, several insulated mountains, whose shadows are quite perceptible, are found here and there in these supposed seas. In the next place, when the boundary of light and darkness passes through these spots, it is not exactly a straight line or a regular curve, as it ought to be were those parts perfectly level like a sheet of water, but appears slightly jagged or uneven. I have inspected these spots hundreds of times, with powers of 150, 180, and 230 times, and in every instance, and in every stage of the moon's increase and decrease, gentle elevations and depressions were seen, similar to the wavings or inequalities which are perceived upon a plain or country generally level. There are scarcely any parts of these spots in which slight elevations may not be seen. In many of them the light and shade, indicating the inequality of surface, are quite perceptible; and in certain parts ridges nearly parallel, of slight elevation, with interjacent plains, are distinctly visible. These dark spots, therefore, must be considered as *extensive plains* diversified with gentle elevations and depressions, and consisting of substances calculated to reflect the light of the sun with a *less degree of intensity* than the other parts of the lunar surface. These plains are of different dimensions, from 40 or 50 to 700 miles in extent, and they occupy more than one-third of that hemisphere of the moon which is seen from the earth, and, consequently, will contain nearly three millions of square miles. As the moon, therefore, is diversified with mountains and cavities of forms altogether different from those of our globe, so the plains upon the surface of that orb are far more varied and extensive than the generality of plains which are found on the surface of the earth. It is a globe diversified with an immenso variety of



mountain-scenery, and, at the same time, abounding with plains and valleys of vast extent. But there appear to be no seas, oceans, or any *large* collections of water, though it is possible that small lakes or rivers may exist on certain parts of its surface. As we see only one side of the moon from the earth, we cannot tell what objects or arrangements may exist on its opposite hemisphere, though it is probable that that hemisphere does not differ *materially* in its scenery and arrangements from those which are seen on the side which is turned toward the earth.

*Atmosphere of the Moon.*—Whether the moon has an atmosphere, or body of air similar to that which surrounds the earth, has been a subject of dispute among astronomers. On the one side, the existence of such an atmosphere is denied, because the stars which disappear behind the body of the moon retain their full luster until they seem to touch its very edge, and then they vanish in a moment; which phenomenon, it is supposed, would not happen if the moon were encompassed with an atmosphere. On the other hand, it has been maintained that the phenomena frequently attending eclipses of the sun furnish arguments for the existence of a lunar atmosphere. It has been observed on different occasions that the moon in a solar eclipse was surrounded with a luminous ring, which was most brilliant on the side nearest the moon; that the sharp horns of the solar crescent have been seen blunted at their extremities during total darkness; that, preceding the emersion, a long narrow streak of dusky red light has been seen to color the western limb of the moon; and that the circular figure of Jupiter, Saturn, and the fixed stars has been seen changed into an elliptical one when they approached either the dark or the enlightened limb of the moon; all which circumstances are considered as indications of a lunar atmosphere. The celebrated M. Schroeter, of Lilienthal, made numerous observations in order to determine this question, and many respectable astronomers are of opinion that his observations clearly prove the existence of an atmosphere around the moon. He discovered near the moon's cusps a faint gray light of a pyramidal form, extending from both cusps into the dark hemisphere, which, being the moon's twilight, must necessarily arise from its atmosphere. It would be too tedious to detail all the observations of Schroeter on this point; but the following are the general conclusions: "That the inferior or more dense part of the moon's atmosphere is not more than 1500 English feet high; and that the light of the atmosphere where it could affect the brightness of a fixed star, or deflect the solar rays, does not exceed 5742 feet," or little more than an English mile. A fixed star will pass over this space in less than two seconds of time; and if it emerge at a part of the moon's limb where there is a ridge of mountains, scarcely any observation can be perceptible.

On the whole, it appears most probable that the moon is surrounded with a fluid which serves the purpose of an atmosphere, although this atmosphere, as to its nature, composition, and refractive power, may be very different from the atmosphere which surrounds the earth. It forms no proof that the moon or any of the planets is destitute of an atmosphere because its constitution, its density, and its power of refracting the rays of light are different from ours. An atmosphere may surround a planetary body, and yet its parts be so fine and transparent that the rays of light from a star or any other body may pass through it without being in the least obscured or changing

their direction. In our reasonings on this subject we too frequently proceed on the false principle that everything connected with other worlds must bear a resemblance to those on the earth. But as we have seen that the surface of the moon, in respect to its mountains, caverns, and plains, is very differently arranged from what appears on the landscape of our globe, so we have every reason to conclude that the atmosphere with which that orb may be surrounded is materially different in its constitution and properties from that body of air in which we move and breathe; and it is highly probable, from the diversity of arrangements which exists throughout the planetary system, that the atmospheres of all the planets are variously constructed, and have properties different from each other. Whatever may be the nature of the moon's atmosphere, it is evident that nothing similar to *clouds* exist in it, otherwise they would be quite perceptible by the telescope; and hence we may conclude that neither hail, snow, rain, nor tempests disturb its serenity; for all the parts uniformly present a clear, calm, and serene aspect, as if its inhabitants enjoyed a perpetual spring.

*Magnitude of the Moon.*—The distance of the moon from the earth is determined from its horizontal parallax; and this distance, compared with its *apparent* angular diameter, gives its *real* or linear diameter. The mean horizontal parallax is fifty-seven minutes, thirty-four seconds, and the mean apparent diameter thirty-one minutes, twenty-six seconds. From these *data* it is found that the real diameter of the moon is 2180 miles, which is little more than the one-fourth of the diameter of the earth. The real magnitude of the moon, therefore, is only about one-forty-ninth part of that of the earth. This is found by dividing the cube of the earth's diameter by the cube of the moon's, and the quotient will express the number of times that the bulk of the earth exceeds that of the moon; for the real bulk of globes is in proportion to the cubes of their diameters. Although the apparent size of the moon appears equal to that of the sun, yet the difference of their real bulk is very great, for it would require more than *sixty-three millions* of globes of the size of the moon to form a globe equal in magnitude to that of the sun. Its surface, notwithstanding, contains a very considerable area, comprising nearly 15,000,000 of square miles, or about one-third of the habitable parts of our globe; and were it as densely peopled as England, it would contain a population amounting to *four thousand two hundred millions*, which is more than five times the population of the earth; so that the moon, although it ranks among the smallest of the celestial bodies, may contain a population of intelligent beings far more numerous, and perhaps far more elevated in the scale of intellect, than the inhabitants of our globe.

Whether it may be possible to discover the inhabitants of the moon is a question which has been sometimes agitated. To such a question I have no hesitation in replying, that it is highly improbable that we shall ever obtain a direct view of any living beings connected with the moon by means of any telescopes which it is in the power of man to construct. The greatest magnifying power which has ever been applied, *with distinctness*, to the moon, does not much exceed a thousand times; that is, makes the objects in the moon appear a thousand times larger and nearer to the naked eye. But even a power of a thousand times represents the objects on the lunar surface at a

distance of 240 miles, at which distance no living beings, although they were nearly of the size of a kraken, could be perceived. Even although we could apply a power of ten thousand times, lunar objects would still appear 24 miles distant; and at such a distance no animal, even of the size of an elephant or a whale, could be discerned. Beside, we ought to consider that we have only a *bird's-eye view* of the objects on the moon; and, consequently, supposing any beings resembling man to exist on that orb, we could only perceive the diameter of their heads, as an aeronaut does when he surveys the crowds beneath him from an elevated balloon. Nay, though it were possible to construct a telescope with a power of one hundred thousand times, which would cause the moon to appear as if only two and a half miles distant, it is doubtful if, even with such an instrument, living beings could be perceived. We ought also to consider that nature has set certain limits to the magnifying power of telescopes; for, although we could apply such powers as now stated to any telescope, the vapors and undulations of the atmosphere, and the diurnal motion of the earth, would interpose a barrier to distinct vision; and as the quantity of light is diminished in proportion to the magnifying power, the loss of light in such high powers would prevent the distinct perception of any object.

But although we can never hope to see any of the inhabitants of the moon by any instrument constructed by human ingenuity, yet we may be able to trace the operations of sentient or intelligent beings, or those effects which indicate the agency of living beings. A navigator who approaches within a certain distance of a small island, although he perceives no human beings upon it, can judge with certainty that it is inhabited if he perceive human habitations, villages, corn-fields, or traces of cultivation. In like manner, if we could perceive changes or operations in the moon which could be traced to the agency of intelligent beings, we should then obtain demonstrative evidence that such beings exist on that planet; and I have no doubt that it is possible to trace such operations. A telescope which magnifies 1200 times will enable us to perceive, as a *visible point* on the surface of the moon, an object whose diameter is only about 100 yards or 300 feet. Such an object is not larger than many of our public edifices; and, therefore, were any such edifices rearing in the moon, or were a town or city extending its boundaries, or were operations of this description carrying on in a district where no such edifices had previously been erected, such objects and operations might probably be detected by a minute inspection. Were a multitude of living creatures moving from place to place in a body, or were they encamping in an extensive plain like a large army, or like a tribe of Arabs in the desert, and afterward removing, it is possible that such movements might be traced by the difference of shade or color which such movements would produce. In order to detect such minute objects and operations, it would be requisite that the surface of the moon should be distributed among at least a hundred astronomers, each having a spot or two allotted him as the object of his more particular investigation, and that the observations be continued for a period of at least thirty or forty years, during which time certain changes would probably be perceived, arising either from physical causes or from the operations of living agents. But although no such changes should ever be detected, it would form no proof that the moon is destitute of in-

habitants; for, in other worlds, intelligent beings may probably enjoy all the happiness congenial to their natures without those edifices or artificial accommodations which are requisite for man in this terrestrial abode. In reference to the subject under consideration, Dr. Olbers is fully of opinion "that the moon is inhabited by rational creatures, and that its surface is more or less covered with a vegetation not very dissimilar to that of our own earth." Gruithuisen maintains that he has discovered, by means of his large achromatic telescope, "great artificial works in the moon, erected by the lunarians." And lately, another foreign observer maintains, from actual observation, "that great edifices do exist in the moon." I am of opinion that all such announcements are premature and uncertain. Without calling in question the accuracy of the descriptions published by these astronomers, there is some reason to suspect that what they have taken for "edifices" and "artificial works" are only small portions of natural scenery, of which an immense variety, in every shape, is to be found on the surface of the moon. Future and more minute observations may, however, enable us to form a definite opinion on this subject.\*

\* A short time ago a *hoax* was attempted to be played off on the public in relation to this subject. An article entitled "Wonderful Discoveries in the Moon, by Sir John Herschel," was copied into most of the American, French, and British newspapers and other periodicals, and was likewise published in a separate pamphlet. It is not a little astonishing how easily the public is gulled by such extravagant descriptions as were contained in this pamphlet, and it shows the *ignorance* which still prevails among the great mass of the community in every country in relation to astronomy and optics, that such pretended discoveries should have been listened to even for a moment. For even some editors of newspapers treated the affair in a grave manner, and only expressed their *doubts* on the subject, plainly indicating that they had far less knowledge of the science of astronomy than many schoolboys now acquire. The title of the pamphlet was sufficient to convince any man of common understanding, who directed his attention for a moment to the subject, that the whole was a piece of deception; for it stated that "the object-glass weighed *seven tons*," and had "a magnifying power of 42,000 times." Now, supposing such a power had been used, the objects on the surface of the moon would still have appeared more than five miles and two-thirds distant; and how could an animal, even of the largest size, be seen at such a distance? Yet the writer of the pamphlet declares that animals such as sheep, and cranes, and small birds were not only distinguished, but the shape and color of their horns, eyes, beards, and the difference of sexes, were perceived. To perceive such objects it was requisite that they should have been brought within six yards instead of six miles. The author might have rendered his description more consistent by putting a power of 200,000 times upon his imaginary telescope, since he had every power at his command, so as to have brought the objects, at least, within the distance of a mile. The author of this deception, I understand, is a young man in the city of New York, who makes some pretensions to scientific acquirements, and he may perhaps be disposed to congratulate himself on the success of his experiment on the public. But it ought to be remembered that all such attempts to deceive are violations of the laws of the Creator, who is the "God of truth," and who requires "truth in the inward parts;" and, therefore, they who willfully and deliberately contrive such impositions ought to be ranked in the class of liars and deceivers. The "Law of Truth" ought never for a moment to be sported with. On the universal observance of this law depends the happiness of the whole intelligent system and the foundations of the throne of the Eternal. The greatest part of the evils which have afflicted our world have risen from a violation of this law, and were it to be *universally* violated, the inhabitants of all worlds would be thrown into a state of confusion and misery, and creation transformed into a chaos. Beside, the propagation of such deceptions is evidently injurious to the interests of science. For when untutored minds and the mass of the community detect such impositions, they are apt to call in question the *real* discoveries of science, as if they were only attempts to impose on their credulity. It is to be hoped that the author of the deception to which I have adverted, as he advances in years and in wisdom, will perceive the folly and immorality of such conduct.

It has sometimes been a subject of speculation whether it might be possible, by any symbols, to correspond with the inhabitants of the moon. "Gruithuisen, in a conversation with the great continental astronomer Gauss, after describing the regular figures he had discovered in the moon, spoke of the possibility of a correspondence with the lunar inhabitants. He brought to Gauss' recollection the idea he had communicated many years ago to Zimmerman. Gauss answered, that the plan of erecting a geometrical figure on the plains of Siberia corresponded with his opinion, because, according to his view, a correspondence with the inhabitants of the moon could only be begun by means of such mathematical contemplations and ideas which we and they must have in common.\* Were the inhabitants of the moon to recognize such a figure, erected on an immense scale, as a signal of correspondence, they might perhaps erect a similar one in reply. But it is questionable whether the intention of such a signal would be recognized; and our terrestrial sovereigns are too much engaged in plunder and warfare to think of spending their revenues in so costly an experiment; and, therefore, it is likely that, for ages to come, we shall remain in ignorance of the genius of the lunar inhabitants. Schemes, however, far more foolish and preposterous than the above have been contrived and acted upon in every age of the world. The millions which are now wasting in the pursuits of mad ambition and destructive warfare might, with far greater propriety, be expended in constructing a large triangle or ellipsis, of many miles in extent, in Siberia or any other country, which might at the same time accommodate thousands of inhabitants who are now roaming the deserts like the beasts of the forest.

Whatever may be the arrangements of the moon or the genius of its inhabitants, we know that it forms a most beautiful and beneficial appendage to our globe. When the sun has descended below the western horizon, the moon lights up her lamp in the azure firmament, and diffuses a mild radiance over the landscape of the world. She pours her luster on spacious cities and lofty mountains, glittering on the ocean, the lakes, and rivers, and opening a prospect wide as the eye can reach, which would otherwise be involved in the deepest gloom. As the son of Sirach has observed, "She is the beauty of heaven, the glory of the stars, an ornament giving light in the high places of the Lord." She cheers the traveler in his journeys, the shepherd while tending his fleecy charge, and the mariner while conducting his vessel at midnight through the boisterous ocean. She returns to us, during night, a portion of the solar light which we had lost, and diffuses a brilliancy far superior to that which we derive from all the stars of heaven. If we intend to prosecute our journeys after the sun has left our hemisphere, the moon, in her increase, serves as a magnificent lamp to guide our footsteps. If we wish to commence our progress at an early hour in the morning, the moon, in her decrease, diffuses a mild radiance in the east, and enables us to anticipate the dawn; and if we choose to defer our journey until the period of full moon, this celestial lamp enables us to enjoy, as it were, an uninterrupted day of twenty-four hours long. By this means we can either avoid the burning heats of summer, or dispatch such business as may be inexpedient during the light of day. While the

apparent revolution of the sun marks out the year and the course of the seasons, the revolution of the moon round the heavens marks out our months; and, by regularly changing its figure at the four quarters of its course, subdivides the month into periods of weeks; and thus exhibits to all the nations of the earth a "watchlight" or signal, which every seven days presents a form entirely new, for marking out the shorter periods of duration. By its nearness to the earth, and the consequent increase of its gravitating power, it produces currents in the atmosphere, which direct the course of the winds and purify the aerial fluid from noxious exhalations; it raises the waters of the ocean, and produces the regular returns of ebb and flow, by which the liquid element is preserved from filth and putrefaction. It extends its sway even over the human frame, and our health and disorders are sometimes partially dependent on its influence. Even its eclipses, and those it produces of the sun, are not without their use. They tend to arouse mankind to the study of astronomy and the wonders of the firmament; they serve to confirm the deductions of chronology, to direct the navigator, and to settle the geographical positions of towns and countries; they assist the astronomer in his celestial investigations, and exhibit an agreeable variety of phenomena in the scenery of the heavens. In short, there are terrestrial scenes presented in moonlight, which, in point of solemnity, grandeur, and picturesque beauty, far surpass in interest, to a poetic imagination, all the brilliancy and splendors of noontide. Hence, in all ages, a moonlight scene has been regarded, by all ranks of men, with feelings of joy and sentiments of admiration. The following description of Homer, translated into English verse by Mr. Pope, has been esteemed one of the finest night-pieces in poetry:

"Behold the moon, refulgent lamp of night,  
O'er heaven's clear azure spread her sacred light,  
When not a breath disturbs the deep serene,  
And not a cloud o'ercasts the solemn scene;  
Around her throne the vivid planets roll,  
And stars unnumbered gild the glowing pole;  
O'er the dark trees a yellower verdure shed,  
And tip with silver every mountain's head;  
Then shine the vales; the rocks in prospect rise,  
A flood of glory bursts from all the skies.  
The conscious swains, rejoicing in the sight,  
Eye the blue vault, and bless the useful light."

Without the light of the moon, the inhabitants of the polar regions would be for weeks and months immersed in darkness. But the moon, like a kindly visitant, returns at short intervals in the absence of the sun, and cheers them with her beams for days and weeks together. So that, in this nocturnal luminary, as in all the other arrangements of nature, we behold a display of the paternal care and beneficence of that Almighty Being who ordained "the moon and stars to rule the night," as an evidence of his superabundant goodness, and of "his mercy, which endureth for ever."

## II. ON THE SATELLITES OF JUPITER.

There are four moons or satellites attending the planet Jupiter, which revolve around it from west to east, according to the order of the signs, or in the same direction as the moon revolves round the earth and the planets round the sun. They are placed at different distances from the center of Jupiter; they revolve round it in different periods of time, and they accompany the planet in its twelve years' revolution round the sun, without deviating in the least in their dis-

\* Edinburgh New Philosophical Journal for October, 1826, p. 390.

tances from the planet, as the more immediate center of their motions. These bodies were discovered by Galileo, who first applied the telescope to celestial observations. Three of them were first seen on the night of the 7th of January, 1610, and were at first supposed to be telescopic stars; but by the observations of three or four subsequent evenings, he discovered them to be attendants on the planet Jupiter. On the 13th of the same month he saw the fourth satellite, and continued his observations until March 2, when he sent his drawings of them, and an account of his observations, to his patron, *Cosmo Medici*, Great Duke of Tuscany, in honor of whom he called them the *Medicean stars*. This discovery soon excited the attention of astronomers, and every one hastened with eagerness to view the new celestial wonders. The senators of Venice who were eminent for their learning, invited Galileo to come to the tower of St. Mark, and in their presence make a trial of his new instruments. He complied with their request, and in a fine night, neither cold nor cloudy, showed them with his instrument the new phenomena which had excited attention; the satellites of Jupiter, the crescent of Venus, the triple appearance of Saturn, and the inequalities on the surface of the moon, which many of the learned refused to admit, because they overthrew the system of the schools and the philosophical notions which had previously prevailed. At this conference with the Venetian senators Galileo demonstrated the truth of the Copernican system, and showed how all his discoveries had a tendency to prove that the earth is a moving body, and that the sun is the center of the planetary motions.

The following are the respective distances of the satellites of Jupiter, in round numbers, and the periodic times in which they revolve around that planet. The mean distance of the first satellite from the center of Jupiter is 260,000 miles, or somewhat more than the distance of the moon from the earth; and it revolves around the planet in 1 day, 18 hours, 27½ minutes. The second satellite is distant 420,000 miles, and finishes its revolution in 3 days, 13 hours, 13½ minutes.—The third is distant 670,000 miles, and performs its revolution in 7 days, 3 hours, 42½ minutes. The fourth satellite is distant 1,180,000 miles, or more than four times the distance of the first, and requires 16 days, 16 hours, and 32 minutes to complete its revolution. These satellites suffer numerous eclipses in passing through the shadow of Jupiter, as our moon is eclipsed in passing through the shadow of the earth. But as their orbits are very little inclined to the orbit of Jupiter, their eclipses are much more frequent than those of our moon. The first three satellites are eclipsed every time they are in opposition to the sun. The first satellite is in opposition once in 42½ hours, and, consequently, suffers an eclipse about eighteen times every month. The second suffers eight or nine eclipses, and the third about four eclipses every month. But the fourth satellite frequently passes through its opposition without being involved in the shadow of Jupiter, and, consequently, its eclipses are less frequent than those of the other three, only a few of them happening in the course of a year. As those satellites are opaque globes like our moon—when they are in their inferior conjunction, or in a line between Jupiter and the sun—their bodies are interposed between the sun and certain parts of the disc of the planet, so as to cause an eclipse of the sun to those places over which their shadow passes. These eclipses, or the shadows of the satellites passing across the

body of Jupiter, are perceived by powerful telescopes. Sometimes the satellites themselves may be seen crossing the disc like luminous spots; and sometimes the body of the planet interposes between our eye and the satellites, when they are said to suffer an *occultation*. It has been ascertained, by the calculations and investigations of La Place, that the whole number of these moons can never be eclipsed at the same time, and that scarcely ever more than two of them can be eclipsed at once.

The following diagram (Fig. 86), exhibits the system of Jupiter's satellites nearly in the proportion of their distances from the planet. The small circles on the orbit of the third satellite represent the enlightened side of the satellites turned toward the sun, and the dark side in an opposite direction. The enlightened side of every satellite is always very nearly turned toward the earth; but in their revolutions round Jupiter they present to that planet all the phases of the moon, as represented in the figures marked on the orbit of the fourth satellite. In the direction *A*, when in opposition to the sun, they appear like *full moons*; in the direction *B* they assume a *gibbous* phase; at *C* they appear like a *half moon*; at *D* like a *crescent*; at *E*, the dark side being turned toward the planet, the satellite becomes invisible; at *F*, *G*, and *H*, it again successively appears under a crescent, a half moon, and a gibbous phase. In the direction *A* the satellites are in opposition to the sun, as seen from Jupiter, at which time they pass through his shadow, and are eclipsed for the space of more than two hours, with the exception of the fourth, which sometimes passes the point of its opposition without falling into the shadow. At *E* the shadow of the satellite passes across the disc of Jupiter, producing a solar eclipse to all those regions on his surface over which the shadow moves.

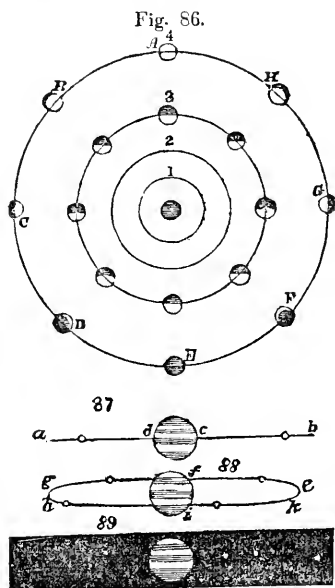

These satellites, when viewed from the earth, do not appear to revolve round Jupiter in the manner here represented, but seem to oscillate backward and forward nearly in a straight line. This is owing to our being nearly on a level with the plane of their orbits. When the earth is i.

one of the geocentric nodes of a satellite, the plane of its orbit passes through our eye, and therefore it appears to be a straight line, as *a b*, (Fig. 87), so that, in passing the half of its orbit which is most distant from the earth, it first seems to move from *b* to *c*, when it is hidden for some time by the planet, and then from *d* to *a*, the point of its greatest elongation; after which it seems to return again in the same line, passing between us and the disc of the planet, until it arrives at its greatest elongation at *b*. In every other situation of the earth, the orbit of a satellite appears as an ellipsis more or less oblong, as represented in Fig. 88. When it passes through its superior semicircle, or that which is more distant from the earth than Jupiter is, as *e, f, g*, its motion is *direct*, or according to the order of the signs; when it is in its inferior semicircle, nearer to us than Jupiter, as *h, i, k*, its apparent motion is in the opposite direction, or *retrograde*. Hence these satellites, as seen through a telescope, appear nearly in a straight line from the body of Jupiter, as represented in Fig. 89.

*Magnitude of the Satellites.*—These bodies, though invisible to the naked eye, are nevertheless of a considerable size. The following are their diameters in miles, as stated by Struve. The first satellite is 2508 miles in diameter, which is considerably larger than our moon. The second is 2068 miles in diameter, or about the size of the moon. The third is 3377 miles in diameter, which is more than seven times the bulk of the moon.—The fourth is 2990 miles in diameter, or about three times the bulk of the moon; so that the whole of Jupiter's satellites are equal to nearly thirteen of our moons.\* The superficial contents of the first satellite is 19,760,865 square miles; of the second, 13,435,442; of the third, 35,827,211; and of the fourth, 26,238,957 square miles. The number of square miles on all the satellites, is therefore, 95,262,475, or more than ninety-five millions of square miles, which is about double the quantity of surface on all the habitable parts of our globe. At the rate of 280 inhabitants to every square mile, these satellites would, therefore be capable of containing a population of 26,673 millions, which is thirty-three times greater than the population of the earth.

The satellites of Jupiter may be seen with a telescope magnifying about thirty times; but in order to perceive their eclipses with advantage, a power of one hundred or one hundred and fifty times is requisite. When the brilliancy of the satellites is examined at different times, it appears to undergo a considerable change. By comparing the mutual positions of the satellites with the times when they acquire their maximum of light, Sir W. Herschel concluded that, like the moon, they all turned round their axis in the same time that they performed their revolution round Jupiter. The same conclusion had been deduced by former astronomers in reference to the fourth satellite. This satellite was sometimes observed to take but half the usual time in its entrance on the disc of Jupiter or its exit from it, which was supposed to be owing to its having a dark spot upon it that covered half its diameter; and, by observ-

ing the period of its variations, it was concluded that it had a rotation round its axis. These circumstances form a presumptive proof that the surface of these satellites, like our moon, are diversified with objects of different descriptions, and with varieties of light and shade. Cassini suspected the first satellite to have an atmosphere, because the shadow of it could not be seen, when he was sure it should have been, upon the disc of Jupiter, if it had not been shortened by its atmosphere, as in the case in respect to the shadow of the earth in lunar eclipses.

From what has been stated respecting the motions, magnitudes and eclipses of these satellites, it is evident they will present a most diversified and sublime scenery in the firmament of Jupiter.—The first satellite moves along a circumference of 1,633,632 miles in the space of 42½ hours, at the rate of 38,449 miles an hour, which is a motion sixteen times more rapid than that of the moon in its circuit round the earth. During this short period it presents to Jupiter all the appearances of a new moon, crescent, half moon, gibbous phase, and full moon, both in the increase and decrease; so that, in the course of twenty-one hours, it passes through all the phases which our moon exhibits to us; beside suffering an eclipse in passing through the shadow of the planet, and producing either a partial or total eclipse of the sun to certain regions of Jupiter on which its shadow falls. The rapidity of its motion through the heavens will also be very striking; as it will move through the whole hemisphere of the heavens in the course of twenty-one hours, beside its daily apparent motion, in consequence of the diurnal rotation of Jupiter. The other three satellites will exhibit similar phenomena, but in different periods of time. Sometimes two or three of these moons, and sometimes all the four, will be seen shining in the firmament at the same time; one like a crescent, one like a half-moon, and another in all its splendor as a full enlightened hemisphere; one entering into an eclipse, another emerging from it; one interposing between the planet and the sun, and for a short time intercepting his rays; one advancing from the eastern horizon, and another setting in the west; one satellite causing the shadows of objects on Jupiter to be thrown in one direction, and another satellite causing them to be projected in another, or in an opposite direction; while the rapid motions of these bodies among the fixed stars will be strikingly perceptible. Eclipses of the satellites and of the sun will be almost an every-day phenomenon, and occultations of the fixed stars will be so frequent and regular as to serve as an accurate measure of time.

The eclipses of Jupiter's satellites afford signals of considerable use for determining the longitude of places on the earth. For this purpose tables of these eclipses, and of the times at which the satellites pass across the disc of Jupiter or behind his body, are calculated and inserted in the nautical and other almanacs. These tables are adapted to the meridian of the Royal Observatory at Greenwich; and by a proper use of them, in connection with observations of the eclipses, the true meridian, or the distance of a place east or west from Greenwich, may be ascertained. For example: suppose, on the 27th of December, 1837, the immersion of Jupiter's first satellite be observed to happen, in an unknown meridian, at 15 hours, 23 minutes, 10 seconds, I find by the tables that this immersion will happen at Greenwich at 13 hours, 34 minutes, 50 seconds of the same day. The difference of the time is 1 hour, 48 minutes, 20 seconds, which, being converted

\*Former astronomers reckoned the bulk of the satellites larger than the dimensions here stated. Cassini and Maraldi reckoned the diameter of the third satellite to be one-eighth of the diameter of Jupiter, and, consequently, nearly 500 miles in diameter; and the first and second to be one-twentieth of Jupiter's diameter, or about 4450 miles; which estimation would make the magnitudes of these bodies much larger than stated by Struve.

into degrees of the equator (allowing 15 degrees for an hour), will make 27 degrees, 5 minutes, which is the longitude of the place of observation. This longitude is *east* of Greenwich, because the time of observation was *in advance* of the time at the British observatory. Had the time of observation been behind that of Greenwich, for example, at 13 hours, 4 minutes, 50 seconds, the place must then have been  $7\frac{1}{2}$  degrees west of the Royal Observatory. *Before* Jupiter's opposition to the sun, or when he passes the meridian in the morning, the shadow is situated to the *west* of the planet, and the *immersions* happen on that side; but *after* the opposition the *emersions* happen to the *east*. These eclipses cannot be observed with advantage unless Jupiter be eight degrees *above*, and the sun at least eight degrees *below* the horizon.

The eclipses of Jupiter's moons first suggested the idea of the *motion of light*. As the orbit of the earth is concentric with that of Jupiter, the mutual distance of these two bodies is continually varying. In the following figure let *S* represent

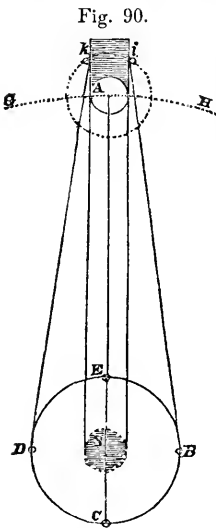

Fig. 90.

the sun; *B, C, D, E*, the orbit of the earth; and *G, H*, a portion of the orbit of Jupiter. It is evident that when the earth is at *E* and Jupiter at *A*, the earth will be the semidiameter of its orbit nearer Jupiter than when it is at *B* or *D*; and when at *C* it will be the whole diameter of its orbit, or 190,000,000 of miles farther from Jupiter than when it is at *E*. Now if light were instantaneous, the satellite *i*, to a spectator at *B*, would appear to enter into Jupiter's shadow, *k i*, at the same moment of time as to another spectator at *E*. But, from numerous observations, it was found, that when the earth was at *E*, the immersion of

the satellite into the shadow happened sooner by eight minutes and a quarter than when the earth was at *B*, and sixteen minutes and a half sooner than when the earth was at *C*. It was therefore concluded that light is not instantaneous, but requires a certain space of time to pass from one region of the universe to another, and that the time it takes in passing from the sun to the earth, or across the semidiameter of the earth's orbit, is eight minutes and a quarter, or at the rate of 192,000 miles every second, which is more than ten hundred thousand times swifter than a cannon ball the moment it is projected from the mouth of the cannon; and therefore it is the swiftest movement with which we are acquainted in nature. It follows that, if the sun was annihilated, we should see him for eight minutes afterward; and if he were again created, it would be eight minutes before his light would be perceived. The motion of light deduced from the eclipses of Jupiter's satellites has been confirmed by Dr. Bradley's discovery of the *aberration of light* produced by the annual motion of the earth, from which it appears that the light from the fixed stars moves with about the same velocity as the light of the sun.

### III. ON THE SATELLITES OF SATURN.

Saturn is surrounded with no less than seven satellites, which revolve around him, at different distances, in a manner similar to those of Jupiter. As they are more difficult to be perceived than the satellites of Jupiter, owing to the great distance of Saturn from the earth, none of them were discovered until the telescope was considerably improved; and more than a century intervened after the first five satellites until the sixth and seventh were detected. As was to be supposed, the larger satellites were first discovered. In the year 1665, about forty-five years after the invention of the telescope, M. Huygens, a celebrated Dutch mathematician and astronomer, discovered the fourth satellite, which is the largest, with a telescope twelve feet long. Four of the others were discovered by Cassini; the fifth in 1671, which is next in brightness to the fourth; the third in December, 1672; and the first and second in the month of March, 1684. These four satellites were first observed by common refracting telescopes of 100 and 136 feet in length; but, after being acquainted with them, he could see them all, in a clear sky, with a tube of thirty-four feet. The sixth and seventh satellites, were discovered by Sir W. Herschel in August, 1789, soon after his large forty-foot reflecting telescope was completed. These are nearer to Saturn than the other five; but, to avoid confusion they are named in the order of their discovery. The following is the order of the satellites in respect of their distance from Saturn:

Seventh.	Sixth.	First.	Second.	Third.	Fourth.	Fifth.
1	2	3	4	5	6	7

The motions and distances of these bodies have not been so accurately ascertained as those of Jupiter. The following statement contains a neat approximation of their periods and distances. The seventh satellite, or that nearest to Saturn, is distant 120,000 miles from the center of the planet, about 80,000 from its surface, and only about 18,000 miles beyond the edge of the outer ring. It moves round the planet in twenty-two hours, thirty-seven minutes, a circuit of 377,000 miles, at the rate of 16,755 miles an hour. The sixth satellite, or the second from Saturn, is distant 150,000 miles, and finishes its revolution in one day, eight hours, fifty-three minutes. The first of the old satellites, or the third from Saturn, finishes its periodical revolution in one day, twenty-one hours, eighteen minutes, at the distance of 190,000 miles. The second (or fourth from Saturn), in two days, seventeen hours, forty four and three-quarter minutes, at the distance of 243,000 miles. The third (fifth from Saturn), in four days, twelve hours, fifty-five minutes, at the distance of 340,000 miles. The fourth (sixth from Saturn), in fifteen days, twenty-two hours fifty-one minutes, at the distance of 788,000 miles. The fifth (seventh from Saturn), in seventy-nine days, seven hours, and fifty-four and a half minutes, at the distance of 2,297,000 miles.

The orbits of the six inner satellites are inclined about thirty degrees to the plane of Saturn's orbit, and lie almost exactly in the plane of the rings, and therefore they appear to move in ellipses similar to the ellipses of the rings. But the orbit of the fifth or outer satellite, makes an angle with the plane of Saturn's orbit of 24 degrees, 45 minutes. These satellites, having their orbits inclined at so great angles to Saturn, cannot cross the body of that planet, or go behind it, or pass

th. ough its shadow, as Jupiter's satellites do, except on rare occasions, and hence they very seldom suffer eclipses or occultations. The only time when eclipses happen is near the periods when the ring is seen edgewise. The fifth or most distant satellite is sometimes invisible in the eastern part of its orbit, which is supposed to arise from one part of the satellite being less luminous than the rest. Sir W. Herschel observed this satellite through all the variations of its light, and concluded, as Cassini had done before, that it turned round its axis like our moon, in the same time that it performed its revolution round Saturn. In consequence of this rotation, the obscure part of its disc is turned toward the earth when in the part of its orbit east of Saturn; and the luminous portion of its surface is turned to the earth and becomes visible while it passes through the western part of its course.

Of these satellites the two innermost are the smallest and the most difficult to be perceived.—They have never been discerned but with most powerful telescopes, and then under peculiar circumstances. At the time of the disappearance of the ring, "they have been seen threading, like beads, the most infinitely thin fiber of light to which it is then reduced, and, for a short time, advancing off it at either end." Few astronomers beside Sir W. Herschel and his son have been able to detect these small bodies. The celebrated Schroeter and Dr. Harding, on the 17th, 20th, 21st, and 27th of February, 1798, obtained several views of the sixth satellite (the second from Saturn) by means of a reflecting telescope 13 feet long, carrying a power of 288. Their observations fully confirmed the accuracy of Sir W. Herschel's statement of the period of its revolution. The first and second satellites (third and fourth from Saturn) are the next smallest; the third (fifth from Saturn) is greater than the first and second; the fourth (sixth from Saturn) the most conspicuous and the most distant satellite, according to Sir John Herschel, is by far the largest, although it is not so conspicuous in one part of its orbit. In order to see any of the satellites of this planet, a good telescope, with a power of at least 70 or 80 times, is requisite, and with such a power only the two outermost satellites will be perceived. To perceive all the five old satellites requires a power of at least 200 times, and a considerable quantity of light.

*Magnitude of Saturn's Satellites.*—The precise bulk of these satellites has not yet been accurately determined. Sir John Herschel estimates the most distant satellite, which he thinks the largest, as not much inferior in size to the planet Mars, which is 4200 miles in diameter. The fourth satellite, which is the most conspicuous, cannot be supposed to be much inferior to it in bulk.—But as the precise dimensions of most of the inner satellites cannot be estimated with accuracy, we shall not, perhaps, exceed the dimensions of these bodies if we suppose for the whole a general average of 3000 miles diameter for each. On this assumption, the surface of each satellite will contain 28,274,400 of square miles, which is nearly double the area of our moon. The area of all the seven satellites will therefore amount to 197,920,800 square miles, which is four times the quantity of surface on all the habitable parts of the earth. At the rate of 280 inhabitants to the square mile, these satellites would therefore contain 55,417,824,000, or more than *fifty-five thousand millions* of inhabitants, which is sixty-nine times the population of our globe.

These satellites will present a beautiful and

variegated appearance in the firmament of Saturn; the nearest satellite, being only 80,000 miles from the *surface* of the planet, which is only the one-third of the distance of the moon from the earth, will exhibit a very large and splendid appearance. Supposing it to be only about the diameter of our moon, it will present a surface nearly nine times larger than the moon does to us; and in the course of twenty-two and a half hours will exhibit all the phases of a crescent, half moon, full moon, &c., which the moon presents to us in the course of a month; so that almost every hour its phase will be sensibly changed, and its motion round the heavens will appear exceedingly rapid. While, in consequence of the diurnal rotation of Saturn, it will appear to move from east to west, it will also be seen moving with a rapid velocity among the stars in a contrary direction, and will pass over a whole hemisphere of the heavens in the course of eleven hours. The next satellite in order from Saturn, being only 110,000 miles from its surface, will also present a splendid appearance, much larger than our moon, and will exhibit all the phases of the moon in the course of sixteen hours. All the other satellites will exhibit somewhat similar phenomena, but in different periods of time. They will appear, when viewed from the surface of Saturn, of different sizes; some of them nine times larger than the moon appears to us, some three times, some double the size, and it is probable that even the most distant satellites will appear nearly as large as our moon, so that a most beautiful and sublime variety of celestial phenomena will be presented to a spectator in the heavens of Saturn, beside the diversified aspects of the rings to which we formerly adverted, all displaying the infinite grandeur and beneficence of the Creator.

#### IV. ON THE SATELLITES OF URANUS.

This planet is attended by six satellites, all of which were discovered by Sir W. Herschel, to whom we owe the discovery of the planet itself. The second and fourth satellites were detected in January, 1787, about six years after the planet was discovered: the other four were discovered several years afterward, but their distances and periodical revolutions have not been so accurately ascertained as those of the two first discovered.

The *first* of these satellites, or the nearest to Uranus, completes its sidereal revolution in 5 days, 21 hours, and 25 minutes, at the distance of 224,000 miles from the center of the planet. The *second* in 8 days, 17 hours, at the distance of 291,000 miles. The *third* in 10 days, 23 hours, at the distance of 340,000 miles. The *fourth* in 13 days, 11 hours, at the distance of 390,000 miles. The *fifth* in 38 days, 1 hour, 48 minutes, at the distance of 777,000 miles. The *sixth* in 107 days, 16 hours, 40 minutes, at the distance of 1,556,000 miles.

These bodies present to our view some remarkable and unexpected peculiarities. Contrary to the analogy of the whole planetary system, *the planes of their orbits are nearly perpendicular to the ecliptic*, being inclined no less than 79 degrees to that plane. Their motions in these orbits are likewise found to be *retrograde*, so that, instead of advancing from west to east round Uranus, as all the other planets and satellites do, they move in the opposite direction. Their orbits are quite circular, or very nearly so, and they do not appear to have undergone any material change of inclination since the period of their discovery. "These anomalous peculiarities," says Sir John Herschel, "seem to occur at the extreme limits of the system,

as if to prepare us for further departure from all its analogies in other systems which may yet be disclosed to us" in the remoter regions of space.

The satellites of Uranus are the most difficult objects to perceive of any within the boundary of the planetary system, excepting the two interior satellites of Saturn; and therefore few observers, excepting Sir William and Sir John Herschel, have obtained a view of them. Their magnitudes, of course, have never been precisely determined; but there is every reason to believe that they are, on an average, as large as the satellites of Saturn, if not larger, otherwise they could not be perceived at the immense distance at which they are placed from our globe. Supposing them, on an average, to be 3000 miles in diameter—and they can scarcely be conceived to be less—the surfaces of all the six satellites will contain 169,646,400 square miles, or about  $3\frac{1}{2}$  times the area of all the habitable portions of the earth; and which, at the rate formerly stated, would afford scope for a population of 47,500,992,000, or above forty-seven thousand millions, which is about sixty times the present number of the inhabitants of the earth.

The satellites of Uranus seldom suffer eclipses; but as the plane in which they move must pass twice in the year through the sun, there may be eclipses of them at those times; but they can be seen only when the planet is near its opposition. Some eclipses were visible in 1799 and 1818, when they appeared to ascend through the shadow of the planet in a direction almost perpendicular to the plane of its orbit. It is probable that this planet is attended with more satellites than those which have yet been discovered. It is not unlikely that two satellites, at least, revolve between the body of the planet and the first satellite; for the third satellite of Saturn is not nearly so far distant from the surface of that planet as the first satellite

of Uranus is from its center. But as the inner satellites may be supposed to be the smallest, and yet present as large a surface to the planet as the exterior ones, it is probable that, on account of their diminutive size, they may never be detected. It is likewise not improbable that two satellites may exist in the large spaces which intervene between the orbits of the fourth and fifth, and the fifth and sixth satellites. All these satellites will not only pour a flood of light on this distant planet, but will exhibit a splendid and variegated appearance in its nocturnal firmament.

The satellites of Jupiter, Saturn, and Uranus, of which we have given a brief description in the preceding pages, form, as it were, so many distinct planetary systems in connection with the great system of the sun. The same laws of motion and gravitation which apply to the primary planets are also applicable to the secondary planets or moons. The squares of their periodical times are in proportion to the cubes of their distances. They are subject to the attraction of their primaries, as all the primary planets are attracted by the sun; and as the sun, in all probability, is carried round a distant center along with all his attendants, so the satellites are carried round the sun along with their respective planets; partly by the influence of these planets, and partly by the attractive power of the great central luminary.—Each of these secondary systems forms a system by itself, far more grand and extensive than the whole planetary system was conceived to be in former times. Even the system of Saturn itself, including its rings and satellites, contains a mass of matter more than a thousand times larger than the earth and moon. The system of Jupiter comprises a mass of matter nearly fifteen hundred times the size of these two bodies; and even that of Uranus is more than eighty times the dimensions of our terrestrial system.

## CHAPTER V.

### ON THE PERFECTIONS OF THE DEITY, AS DISPLAYED IN THE PLANETARY SYSTEM.

ALL the works of nature speak of their Author in language which can scarcely be misunderstood. They proclaim the existence of an original, uncreated Cause, of an eternal Power and Intelligence, and of a supreme agency which no created being can control. "The heavens," in a particular manner, "declare the glory of God, and the firmament showeth forth his handiwork."—When we consider the heavenly orbs in their size, their distance, the rapidity of their motions, and the regularity and harmony with which they perform their respective revolutions, it is obvious to the least attentive observer that such bodies could not have formed themselves, or have arranged their motions, their periods, and their laws in the beautiful order in which we now behold them. Motion of every kind supposes a moving power. As matter could not make itself, so neither can it set itself in motion. Its motion must commence from a power exterior to itself, and that power must correspond in energy to the

effect produced. In the planetary system we find bodies a thousand times larger than the earth moving with a velocity sixty times greater than a cannon ball, and carrying along with them in their train other expansive globes in the same swift career. Such motions could only proceed from a power which is beyond calculation or human comprehension; and such a power can only reside in an uncreated, self-existent, and independent Intelligence. The *continuance* of such motions must likewise depend upon the incessant agency of the same Almighty Being, either directly, or through the medium of such subordinate agents as he is pleased to appoint for the accomplishment of his designs. In this respect the laws of motion, of attraction, gravitation, electricity, and other powers, are so many agents, under the direction and control of the Almighty, for carrying forward the plans of his physical and moral government of the universe.

The study of astronomy ought always to leave



in view as its ultimate object, to trace the Divine perfections as displayed in the phenomena of the heavens. For, as our poet Milton expresses it, "Heaven is as the book of God before us set, wherein to read his wondrous works." There is no scene we can contemplate in which the attributes of the Divinity are so magnificently displayed. It is in the heavens alone that we perceive a sensible evidence of the *infinity* of his perfections, of the grandeur of his operations, and of the immeasurable extent of his universal dominions. Even the planetary system, small as it is in comparison of the whole extent of creation, contains within it wonders of creating Omnipotence and skill which almost overpower the human faculties, and demonstrate the "eternal power and godhead" of Him who at first brought it into existence. To consider astronomy merely as a secular branch of knowledge, which improves navigation, and gives scope to the mathematician's skill, and to overlook the demonstrations it affords of the invisible Divinity, would be to sink this noble study far below its native dignity, and to throw into the shade the most illustrious manifestations of the glories of the Eternal mind.

When we contemplate the stupendous globes of which the planetary system is composed, and the astonishing velocity with which they run their destined rounds, we cannot but be struck with an impressive idea of the power of the Deity; of the incomprehensible ENERGIES of the Eternal Mind that first launched them into existence. What are all the efforts of puny man as displayed in the machinery he has set in motion, and in the most magnificent structures he has reared, in comparison with worlds a thousand times larger than this earthly ball, and with *forces* which impel them in their courses at the rate of thirty thousand, and even a hundred thousand miles an hour! The mind is overpowered and bewildered when it contemplates such august and magnificent operations. Man, with all his imaginary pomp and greatness, appears, on comparison, as a mere microscopic animalcula, yea, as "less than nothing and vanity;" and such displays of the omnipotence of Jehovah are intended to bring down the "lofty looks of men," and to stain the pride of all human grandeur, "that no flesh should glory in his presence." Without materials, and without the aid of instruments or machinery, the foundations of the planetary system were laid, and all its arrangements completed. "He only spake and it was done;" he only gave the *command*, and mighty worlds started into existence and ran their spacious rounds. "By the word of the Lord were the heavens made, and all the host of them by the breath of His mouth." That Almighty Being who, by a single volition, could produce such stupendous effects, must be capable of effecting what far transcends our limited conceptions. His agency must be universal and uncontrollable, and no created being can ever hope to frustrate the purposes of his will or counteract the designs of his moral government. Whatever he has promised will be performed; whatever he has predicted by his inspired messengers must assuredly be accomplished. "For the kingdom is the Lord's, He is the Governor among the nations," and all events, and the movements of all intelligent beings, are subject to his sovereign control. "Though the mountains should be carried into the midst of the seas, and the earth reel to and fro like a drunkard;" yea, though this spacious globe should be wrapped in flames, and "all that it inherits be dissolved," yet that power which brought into existence the planetary

worlds, and has supported them in their rapid career for thousands of years, can cause "new heavens and a new earth, wherein dwelleth righteousness," to arise out of its ruins, and to remain in undiminished beauty and splendor.

"The heavens," says an inspired writer, "declare the glory of the Lord, and there is no speech nor language where their voice is not heard." Even the pagan nations were impressed with the power of a supreme intelligence from a contemplation of the nocturnal firmament. "When we behold the heavens," says Cicero, "when we contemplate the celestial bodies, can we fail of conviction? Must we not acknowledge that there is a Divinity, a perfect being, a ruling intelligence that governs, a God who is everywhere, and directs all by his power? Any one who doubts this may as well deny that there is a sun that enlightens us." Plato, when alluding to the motions of the sun and planets, exclaims, "How is it possible for such prodigious masses to be carried round for so long a period by any natural cause? for which reason I assert God to be the great and first cause, and that it is impossible that it should be otherwise."

A very slight view of the planetary system is sufficient to impress our minds with an overpowering sense of the *grandeur* and *omnipotence* of the Deity. In one part of it we behold a globe fourteen hundred times larger than our world flying through the depths of space, and carrying along with it a retinue of revolving worlds in its swift career. In a more distant region of this system we behold another globe, of nearly the same size, surrounded by two magnificent rings, which would inclose 500 worlds as large as ours, winging its flight through the regions of immensity, and conveying along with it seven planetary bodies larger than our moon, and the stupendous arches with which it is encircled, over a circumference of five thousand seven hundred millions of miles. Were we to suppose ourselves placed on the nearest satellite of this planet, and were the satellite supposed to be at rest, we should behold a scene of grandeur altogether overwhelming; a globe filling a great portion of the visible heavens, encircled by its immense rings, and surrounded by its moons, each moving in its distinct sphere and around its axis, and all at the same time flying before us in perfect harmony with the velocity of 22,000 miles an hour. Such a scene would far transcend everything we now behold from our terrestrial sphere, and all the conceptions we can possibly form of motion, of sublimity, and grandeur. Contemplating such an assemblage of magnificent objects moving through the ethereal regions with such astonishing velocity, we would feel the full force of the sentiments of inspiration: "THE LORD GOD OMNIPOTENT REIGNETH. His power is irresistible; His greatness is unsearchable; wonderful things doth he which we cannot comprehend." The *motions* of the bodies which compose this system convey an impressive idea of the agency and the energies of Omnipotence. One of these bodies, eighty times larger than the earth, and the slowest moving orb in the system, is found to move through its expansive orbit at the rate of fifteen thousand miles an hour; another at twenty-nine thousand miles in the same period, although it is more than a thousand times the size of our globe; another at the rate of eighty thousand miles; and a fourth with a velocity of more than a hundred thousand miles every hour, or thirty miles during every beat of our pulse. The mechanical forces requisite to produce such motions surpass the mathe-

matician's skill to estimate or the power of numbers to express. Such astonishing velocities, in bodies of so stupendous a magnitude, though incomprehensible and overwhelming to our limited faculties, exhibit a most convincing demonstration of the existence of an agency and a power which no created beings can ever counteract, and which no limits can control. Above all, the central body of this system presents to our view an object which is altogether overpowering to human intellects, and of which, in our present state, we shall never be able to form an adequate conception. A luminous globe, thirteen hundred thousand times larger than our world, and five hundred times more capacious than all the planets, satellites, and comets taken together, and this body revolving round its axis and through the regions of space, extending its influences to the remotest spaces of the system, and retaining by its attractive power all the planets in their orbits, is an object which the limited faculties of the human mind, however improved, can never grasp, in all its magnitude and relations, so as to form a full and comprehensive idea of its magnificence. But it displays in a most astonishing manner the GRANDŒUR of Him who launched it into existence, and lighted it up "by the breath of his mouth;" and it exhibits to all intelligences a demonstration of his "eternal power and godhead." So that, although there were no bodies existing in the universe but those of the planetary system, they would afford an evidence of a power to which no limits can be assigned; a power which is infinite, universal, and uncontrollable.

The planetary system likewise exhibits a display of the wisdom and intelligence of the Deity. If it is an evidence of wisdom in an artist that he has arranged all the parts of a machine, and proportioned the movements of its different wheels and pinions so as exactly to accomplish the end intended, then the arrangement of the planetary system affords a bright display of "the manifold wisdom of God." In the center of this system is placed the great source of light and heat; and from no other point could those solar emanations be propagated, in an equable and uniform manner, to the worlds which roll around it. Had the sun been placed at a remote distance from the center, or near one of the planetary orbits, the planets in one part of their course would have been scorched with the most intense heat, and in another part would have been subjected to all the rigors of excessive cold; their motions would have been deranged, and their present constitution destroyed. The enormous bulk of this central body was likewise requisite to diffuse light and attractive influence throughout every part of the system. The diurnal rotations of the planets evince the same wisdom and intelligence. Were these bodies destitute of diurnal motions, one-half of their surface would be parched with perpetual day, and the other half involved in the gloom of a perpetual night. To the inhabitants of one hemisphere the sun would never appear, and to the inhabitants of the other the stars would be invisible; and those expansive regions of the universe, where the magnificence of God is so strikingly displayed, would be forever veiled from their view. The permanency of the axes on which the planets revolve was likewise necessary, in order to the stability of the system and the comfort of its inhabitants; and so we find that their poles point invariably in the same direction or to the same points of the heavens, with only a slight variation scarcely perceptible until after the lapse of centuries. As the planets are of a spheroidal figure,

had the direction of their axes been liable to frequent and sudden changes, the most alarming and disastrous catastrophes might have ensued. In such a globe as ours, the shifting of its axis might change the equatorial parts of the earth into the polar, or the polar into the equatorial, to the utter destruction of those plants and animals which are not capable of interchanging their situations. Such a change would likewise cause the seas to abandon their former positions, and to rush to the new equator; the consequence of which would be, that the greater part of the men and animals with which it is now peopled would be again overwhelmed in a general deluge, and the habitable earth reduced to a cheerless desert. But all such disasters are prevented by the permanent position of the axis of our globe and of the other planets during every part of their annual revolutions, as fixed and determined by Him who is "wonderful in counsel and excellent in working."

The same wisdom is conspicuous in so nicely balancing and proportioning the magnitudes, motions, and distances of the planetary orbs. We find that the larger planets move in orbits most remote from the smaller planets and from the center of the system. If the great planets Jupiter and Saturn had moved in lower spheres and at no great distance from the smaller, their attractive force would have had a much more powerful influence than it now has in disturbing the planetary motions, and might have introduced considerable confusion into the system. But, while they revolve at so great distances from all the inferior planets, their influence is inconsiderable, and the slight perturbations they produce are not permanent, but periodical; they come to a limit, and then go back again to the same point as before. Again, the law of gravitation, by which the planets are directed in their motions, is also an evidence of Divine intelligence. The law is found to act reciprocally as the square of the distance; that is, at double the distance it has one-fourth, and at triple the distance one-ninth of the force; at one-half the distance it has four times, and at one-third the distance it has nine times the strength or influence. Now it could easily be shown, that a law directly opposite to this, or even differing materially from it, would not only derange the harmony of the system, but might be attended with the most disastrous consequences. If, for instance, a planet as large and as remote as Saturn had attracted the earth in proportion to the quantity of matter it contains, and, at the same time, in any proportion to its distance; in other words, had its attractive power been greater the farther it was removed from us, it would have dragged our globe out of its course, deranged its motions, and, in all probability, deprived us of the security we now possess, and of all the prospects and enjoyments which depend upon its equable and harmonious movements. There is no contrivance in the system more wonderful than the rings of Saturn. That these rings should be separated thirty thousand miles from the body of the planet; that they should, notwithstanding, accompany the planet in its revolution round the sun, preserving invariably the same distance from it; that they should revolve round the planet every ten hours, at the immense velocity of more than a thousand miles in a minute; and that they should never fly off to the distant regions of space, nor fall down upon the planet, are circumstances which require adjustments far more intricate and exquisite than we can conceive, and demonstrate that the almighty contriver of that stupendous appendage to the globe of Saturn is "great in counsel

and mighty in operation." Yet these adjustments, in whatever they may consist, have been completely effected. For this planet has been flying through the regions of space in a regular curve for thousands of years, and the system of its satellites and rings still remains permanent and unimpaired as at its first creation.

An evidence of wisdom may likewise be perceived in the *distance* at which each planet is placed from the great central body of the system. In the case of our own globe, its distance from the sun is so adjusted as to correspond to the density of the earth and waters, to the temper and constitution of the bodies of men and other animals, and to the general state of all things here below. The quantity of light which the central luminary diffuses around us is exactly adapted to the structure of our eyes, to the width of their pupils, and the nervous sensibility of the retina. The heat it produces, by its action on the *caloric* connected with our globe, is of such a temperature as is exactly suited to the nature of the soil and to the constitution of the animal and vegetable tribes. It is placed at such a distance as to enlighten and warm us, and not so near as to dazzle us with its splendor or scorch us with its excessive heat; but to cheer all the tribes of living beings, and to nourish the soil with its kindly warmth. Were the earth removed fifty millions of miles farther from the sun, everything around us would be frozen up, and we should be perpetually shivering amid all the rigors of excessive cold. Were it placed as much nearer, the waters of the rivers and the ocean would be transformed into vapor; the earth would be hardened into an impenetrable crust; the process of vegetation would cease; and all the orders of animated beings would faint under the excessive splendor of the solar beams. There can be no doubt that the distances of the other planets are likewise adapted to the nature of the substances of which they are composed and the constitution of their inhabitants. We find that the *densities* of these bodies *decrease* in proportion to their distance from the sun; and it is highly probable that this is one reason, among others, why they are placed at different distances, and are thus adapted to the greater or less degree of influence which the central luminary may produce on their surfaces.

The *figures* of the planetary bodies likewise indicate contrivance and intelligence. They are all either of a spherical or spheroidal form, and this figure is evidently the best adapted to a habitable world. It is the most *capacious* of all forms, and contains the greatest quantity of area in the least possible space. It is the best adapted to motion, both annual and diurnal, every part of the surface being nearly at the same distance from the center of gravity and motion. Without this figure there could have been no comfortable and regular alternations of day and night in our world as we now enjoy, and the light of the sun and the mass of waters could not have been equably distributed. Had the earth been of a cubical, prismatic, or pentagonal form, or of any other angular figure, some parts would have been comparatively near the center of gravity, and others hundreds or thousands of miles farther from it; certain countries would have been exposed to furious tempests, which would have overturned and destroyed every object, while others would have been stifled for want of currents and agitation in the air; one part would have been overwhelmed with water, and another entirely destitute of the liquid element; one part might have

enjoyed the benign influence of the sun, while another might have been within the shadow of elevations a hundred miles high, and in regions of insufferable cold. In short, while one country might have resembled a paradise, others would have been transformed into a chaos, where nothing was to be seen but barrenness and hideous desolation; but the globular figure which the Creator has given to our world prevents all such inconveniences and evils, and secures to us all the advantages we enjoy from the equable distribution of light and gravity, of the waters of our seas and rivers, and of the winds and motions of the atmosphere; and arrangements similar or analogous are enjoyed by all the other planetary worlds, in consequence of the globular figure which has been impressed upon them.

The same Divine Wisdom is displayed throughout the solar system in the *nicely adjustment* of the *projectile velocity* to the *attractive power*. The natural tendency of all motion, impressed by a single force, is to make the body move in a *straight line*. The projectile force originally given to the planets, if not counteracted, would carry them away from the sun, in right lines, through the regions of infinite space. On the other hand, had the planets been acted upon solely by an attractive power proceeding from the center, they would have moved with an increased velocity toward that center, and, in a short time, have fallen upon the body of the sun. Now the Divine Intelligence strikingly appears in nicely proportioning and balancing these two powers, so as to make the planets describe orbits nearly circular. If these powers had not been accurately adjusted, the whole system would have run into confusion. For, were the velocity of any planet double to what would make it move in a circle or ellipse, it would rush from its sphere through the regions of immensity, and never again return to its former orbit. Or, should half its velocity be taken away, the planet would descend obliquely toward the sun until it became four times nearer him than before, and then ascend to its former place; and by ascending and descending alternately, would describe a very eccentric orbit, and would feel the influence of the solar light and power sixteen times greater in one part of its course than in another; which would prevent such a globe as ours, and probably all the planetary bodies, from being habitable worlds. But, in this respect, every part of celestial mechanism is adjusted with the nicest skill, and the whole system appears a scene of beauty, order, and stability worthy of the intelligence of Him "who hath established the world by his wisdom, and stretched out the heavens by his understanding." And as the power of gravitation was first impressed upon matter by the hand of the Creator, so its continued action is every moment dependent on his sovereign will. Were its influence to be suspended, the whole system would immediately dissolve and run into confusion. The centrifugal force of the planets, in whirling round their axes, would shatter them into pieces and dissipate their parts throughout the circumambient spaces; every portion of matter would fly in straight lines, according as the projectile force chanced to direct at the moment this power was suspended; and the regions of infinite space, instead of presenting a prospect of beauty and order, would become a scene of derangement, overspread with the wrecks of all the globes in the universe; so that the order and stability of universal nature entirely depends upon the will and the omnipotence of the Deity in sustaining

in constant action the power of universal gravitation. Were it his pleasure that the material world should be dissolved and its inhabitants destroyed, he has only to interpose his Almighty fiat, and proclaim, "Let the power of attraction be suspended," and the vast universe would soon be unbinged and return to its original chaos.

In short, the depth of the Divine Wisdom might have been illustrated from the constant proportion between the times of the periodical revolutions of all the planets, primary and secondary, and the cubes of their mean distances; from the constancy and regularity of their motions, that, amid so immense a variety of moving masses, all should observe their due bounds and keep their appointed paths, to answer the great ends of their creation; from the exactness with which they run their destined rounds, finishing their circuits with so much accuracy as not to deviate from the periods of their revolutions a single minute in a hundred years; from the *distances* of the several planets from the sun, compared with their respective *densities*; from their velocities in their orbits compared with their distances from the central luminary; from the wonderful simplicity of the laws on which so much beauty, harmony, and enjoyment depend; and from various other considerations, all which would tend to demonstrate that He who framed the planetary system is "the only wise God," whose "understanding is infinite," and the depth of whose intelligence is "past finding out."

From what we have now stated, we may see what a beautiful and divine fabric the solar system exhibits. Like all the arrangements of Infinite Wisdom its foundations are plain and simple, but its superstructure is wonderful and diversified.—The causes which produce the effects are few, but the phenomena are innumerable. While the ends to be accomplished are numerous and various, the means are the fewest that could possibly bring the design into effect. What a striking contrast is presented between the works of Omnipotence as they really exist, and the bungling schemes of the ancient astronomers? who, with all their cycles, epicycles, concentric and eccentric circles, their deferents, and solid crystalline spheres, could never account for the motions of the planetary orbs, nor explain their phenomena. The plans of the Almighty, both in the material world and in his moral government, are quite unlike the circumscribed and complex schemes of man. Like himself, they are magnificent and stupendous, and yet accomplished by means apparently weak and simple. All his works are demonstrations, not only of his existence, but of his inscrutable wisdom and superintending providence. As the accomplishments of every workman are known from the work which he executes, so the operations of the Deity evince his supreme agency and his boundless perfections. What being less than infinite could have arranged the solar system, and launched from his hand the huge masses of the planetary worlds? What mathematician could so nicely calculate their distances and arrange their motions? Or what mechanic so accurately contrive their figures, adjust their movements, or balance their projectile force with the power of gravitation? None but He whose power is supreme and irresistible, whose agency is universal, and whose wisdom is unsearchable.

In the last place, the planetary system exhibits a display of the goodness of the Creator and of his superintending care. The goodness of God is that perfection of his nature by which he delights to communicate happiness to every order of his

creatures. Now all the movements and arrangements of the planetary bodies are so ordered and directed as to act in subserviency to the happiness of sentient and intelligent beings. This is evidently the grand design of all the wise contrivances to which we have adverted. The spherical figure given to all the planets for the regular distribution of the waters of the seas and rivers, and of the currents of the atmosphere; their rotation on their axes, to produce the alternate succession of day and night; the situation of the sun in the center of the system, for the equable distribution of light and heat to surrounding planets; and an apparatus of rings and moons, to reflect a mild radiance in the absence of the sun, are contrivances which can only have a respect to the comfort and convenience of animated beings; for they can serve no purpose to mere inert matter devoid of life and intelligence, and the Creator, so far as we know, never employs means without a corresponding end in view. In our world, the utility of these arrangements, in order to our happiness, is obvious to the least reflecting mind. Without light our globe would be little else than a gloomy prison; for it is this that cheers the heart of man, and unavails to our view the beauties and sublimities of creation; and had the earth no rotation, and were the sun continually shining on the same hemisphere, the temperate zones as well as the equatorial regions would be parched with a perpetual day, the moisture of the soil evaporated, the earth hardened, vegetables deprived of nourishment, the functions of the atmosphere deranged, and numerous other inconveniences would ensue, from which we are now protected by the existing arrangements of nature; and as such contrivances are essential to the comfort of the inhabitants of the earth, so we have every reason to conclude that these and all the additional arrangements connected with other planets are intended to promote the enjoyment of the different orders of sensitive and intelligent existence with which they are peopled.

As the object of the wise contrivances of the Deity is the communication of happiness, it would be inconsistent with every rational view we can take of his wisdom and intelligence not to admit that the same end is kept in view in every part of his dominions, however far removed from the sphere of our immediate contemplation, and though we are not permitted, in the mean time, to inspect the minute details connected with the economy of other worlds; for the Creator must always be considered as consistent with himself, as acting on the same eternal and immutable principles at all times, and throughout every department of his empire. He cannot be supposed to devise means in order to accomplish important ends in relation to our world, while in other regions of creation he devises means for no end at all. To suppose, for a moment, such a thing possible, would be highly derogatory to the Divine character, and would confound all our ideas of the harmony and consistency of the attributes of him who is "the only wise God." We have, therefore, the highest reason to conclude, that not only this earth, but the whole of the planetary system, is a scene of *divine benevolence*; for it displays to our view a number of magnificent globes, with special contrivances and arrangements, all fitted to be the abodes of intelligent beings, and to contribute to their enjoyment. Every provision has been made to supply them with that *light* which unfolds the beauties of nature and the glories of the firmament. All the arrangements for its equable distribution have been effected, and several

wonderful modes unknown in our world have been contrived for alleviating their darkness in the absence of the sun, all which contrivances are, doubtless, accompanied with many others which lie beyond the range of our conception, and which our remote distance prevents us from contemplating. In proportion, then, as the other planets exceed the earth in size, in a similar proportion, we may conceive, is the extent of that theater on which the Divine goodness is displayed. If this "earth is full of the goodness of the Lord," if the benevolence of the Creator has distributed unnumbered comforts among every order of creatures here below, what must be the exuberance of his bounty, and the overflowing streams of felicity enjoyed in worlds which contain thousands of times the population of our globe! If a world which has been partly de-raiged by the sin of its inhabitants abounds with so many pleasures, what numerous sources of happiness must abound, and what ecstasie joys must be felt in those worlds where mortal evil has never entered, where diseases and death are unknown, and where the inhabitants bask perpetually in the regions of immortality! Were we permitted to take a nearer view of the enjoyments of some of those worlds, were we to behold the magnificent scenery with which they are encircled, the riches of Divine munificence which appear

on every hand, the inhabitants adorned with the beauties of moral perfection, and every society cemented by the bond of universal love, and displaying the virtues of angelic natures, it is highly probable that all the enjoyments of this terrestrial sphere would appear only "as the drop of a bucket and the small dust of the balance," and as unworthy of our regard in comparison of the overflowing fountains of bliss which enrich the regions and gladden the society of the celestial worlds. In this point of view what a glorious and *amiable* being does the eternal Jehovah appear! "God is love." This is his name and his memorial in all generations and throughout all worlds. Supremely happy in himself and independent of all his creatures, his grand design in forming and arranging so many worlds could only be to display the riches of his beneficence, and to impart felicity, in all its diversified forms, to countless orders of intelligent beings, and to every rank of perceptive existence. And how *extensive* his goodness is, not only throughout the planetary system, but over all the regions of universal nature, it is impossible for the tongues of men or angels to declare, or the highest powers of intelligence to conceive. But of this we are certain, that "Jehovah is good to all;" that "his bounty is great above the heavens;" and that "his tender mercies are over all his works."

## CHAPTER VI.

## SUMMARY VIEW OF THE MAGNITUDE OF THE PLANETARY SYSTEM.

HAVING, in the preceding pages, given a brief description of the principal facts and phenomena connected with the solar system, and offered a few reflections suggested by the subject, it may not be inexpedient to place before the reader a summary view of the magnitude of the bodies belonging to this system, as compared with the population and magnitude of the globe on which we live. In this summary statement I shall chiefly attend to the *area* or superficial contents of the different

planets, which is the only accurate view we can take of their magnitudes, when we compare them with each other as habitable worlds. The population of the different globes is estimated, as in the preceding descriptions, at the rate of 280 inhabitants to a square mile, which is the rate of population in England, and yet this country is by no means overstocked with inhabitants, but could contain, perhaps, double its present population.

	Square Miles.	Population.	Solid Contents.
Mercury .....	32,000,000	8,960,000,000	17,157,324,800
Venus .....	191,134,944	53,500,000,000	248,475,427,200
Mars .....	55,417,824	15,500,000,000	38,792,000,000
Vesta .....	229,000	64,000,000	10,035,000
Juno .....	6,380,000	1,786,000,000	1,515,250,000
Ceres .....	8,285,580	2,319,962,400	2,242,630,320
Pallas .....	14,000,000	4,000,000,000	4,900,000,000
Jupiter .....	21,884,000,000	6,967,520,000,000	368,283,200,000,000
Saturn .....	19,600,000,000	5,488,000,000,000	261,326,800,000,000
Saturn's outer ring	9,058,803,600	8,141,963,826,080	1,442,518,261,800
Inner ring .....	19,791,501,636		
Edges of the rings	228,077,000		
Uranus .....	3,847,460,000	1,077,568,800,000	22,437,804,620,000
The Moon .....	15,000,000	4,200,000,000	5,455,000,000
Jupiter's satellites	95,000,000	26,673,000,000	45,693,970,126
Saturn's satellites	197,920,800	55,417,824,000	98,960,400,000
Uranus's satellites	169,646,400	47,500,992,000	84,823,200,000
Amount .....	78,195,916,784	21,894,974,404,480	654,038,348,119,246

From the above statement, the real magnitude of all the moving bodies connected with the solar system may at once be perceived. If we wish to ascertain what proportion these magnitudes bear

to the amplitude of our own globe, we have only to divide the different amounts stated at the bottom of the table by the area, solidity, or population of the earth. The amount of area, or the superficial

contents of all the planets, primary and secondary, is 78,195,916,784; or above *seventy-eight thousand millions* of square miles. If this sum be divided by 197,000,000, the number of square miles on the surface of our globe, the quotient will be 397; showing that the surfaces of these globes are 397 times more expansive than the whole surface of the terraqueous globe; or, in other words, that they contain an amplitude of space for animated beings equal to nearly *four hundred worlds* such as ours. If we divide the same amount by 49,000,000, the number of square miles in the habitable parts of the earth, the quotient will be 1595; showing that the surface of all the planets contains a space equal to one thousand five hundred and ninety-five times the area of all the continents and islands of our globe. If the amount of population which the planets might contain, namely, 21,894,974,404,480, or nearly *twenty-two billions*, be divided by 800,000,000, the population of the earth, the quotient will be 27,368; which shows that the planetary globes could contain a population more than twenty-seven thousand times the population of our globe; in other words, if peopled in the proportion of England, they are equivalent to twenty-seven thousand worlds such as ours in its present state of population. The amount of the third column expresses the number of solid miles comprised in all the planets, which is 654,038,348,119,246, or more than *six hundred and fifty-four billions*. If this number be divided by 263,000,-

000,000, the number of cubical miles in the earth, the quotient will be 2483, which shows that the solid bulk of the other planets is two thousand four hundred and eighty-three times the bulk of our globe. Such is the immense magnitude of our planetary system, without taking into account either the sun or the hundreds of comets which have been observed to traverse the planetary regions.

Great, however, as these magnitudes are, they are far surpassed by that stupendous globe which occupies the center of the system. The surface of the sun contains 2,432,800,000,000 square miles (nearly two and a half billions). If this sum be rightly divided by 197 millions, the number of square miles on the earth's surface, the quotient will be 12,350, which shows that the surface of the sun contains *twelve thousand three hundred and fifty* times the quantity of surface on our globe. If the same sum be divided by 78,195,916,784, the number of square miles in all the planets, the quotient will be 31, showing that the area of the surface of the sun is *thirty-one* times greater than the area of all the primary planets, with their rings and satellites. The solid contents of the sun amount to 356,818,739,200,000,000, or nearly three hundred and fifty-seven thousand billions of cubical miles, which number, if divided by 654,038,348,119,246, the number of solid miles in all the planets, will produce a quotient of 545, which shows that the sun is five hundred and forty-five times larger than all the planetary bodies taken together. Such is the vast and incomprehensible magnitude of this stupendous luminary, whose effulgence sheds day over a retinue of revolving worlds, and whose attractive energy controls their motions and preserves them all in one harmonious system. If this immense globe be flying through the regions of space at the rate of sixty thousand miles an hour, as is supposed, and carrying along with it all the planets of the system, it presents to the mind one of the most sublime and overwhelming ideas of motion, magnitude, and grandeur which the scenes of the universe can convey.

The comparative magnitudes of the different bodies in the system are represented to the eye in Fig. 91, where the circle at the top, No. 1, represents Jupiter; No. 2, Saturn; No. 3, Uranus; No. 4, the Earth; adjacent to which, on the left, is the Moon; No. 5, Mars; No. 6, Venus; and No. 7, Mercury. The four small circles at the bottom are the planets Vesta, Juno, Ceres, and Pallas, whose proportional sizes cannot be accurately represented. The other small circles connected with Jupiter, Saturn, and Uranus, are intended to represent the satellites of these planets, which in general may be estimated as considerably larger than our moon. These comparative magnitudes are only approximations to the truth; for it would require a large sheet were we to attempt delineating them with accuracy; but the figure will convey to the eye a *general* idea of the comparative bulks of these bodies, in so far as it can be conveyed by a comparison of their diameters;\* but no repres-

\* The reader will find a comparative view of the distances and magnitudes of the planets, engraved on a very large sheet, in "Burritt's Geography of the Heavens" published at Hartford, North America.

Fig. 92.

Fig. 91.

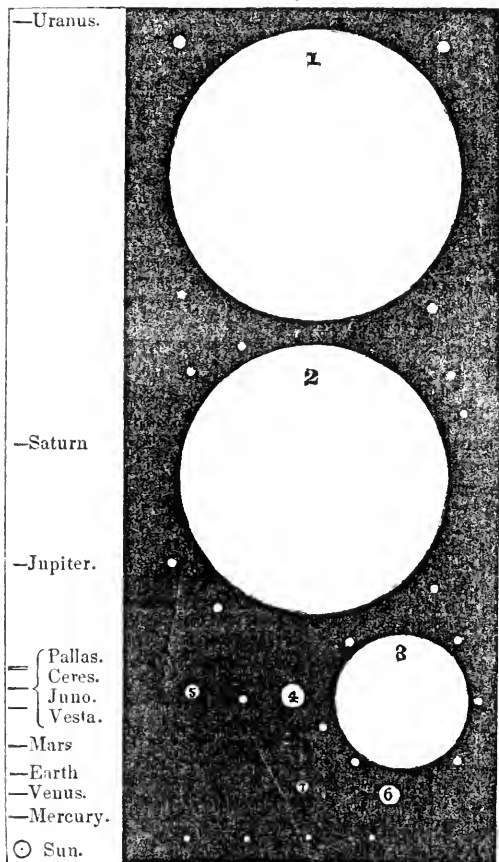

tation on a plane surface can convey an idea of the *solid contents* of these globes as compared with each other. The reader will perceive the great disparity of globes, whose diameters do not differ very widely from each other, if he place a globe of twelve inches diameter beside one of eighteen inches diameter. Though these globes differ only six inches in their diameters, yet he will at once perceive that the eighteen-inch globe contains more than double the surface of the twelve-inch; and the *solid* space which it occupies contains  $3\frac{3}{8}$  times the space occupied by the smaller globe. Were the sun to be represented in its proportional size to Jupiter and the other planets, it would fill a space *twenty inches in diameter*. On the same scale in which the planets are delineated, Saturn's ring would occupy a space four and a half inches in diameter. From these representations we may see how small a space our earth occupies in the planetary system, and what an inconsiderable appearance it presents in comparison with Jupiter, Saturn, and Uranus. Fig. 92 represents the *proportional distances* of the primary planets from the sun, from which it will be seen that Saturn, which was formerly considered the most distant planet, occupies nearly the middle of the system.

In Fig. 93 is represented a comparative view of the earth and the rings of Saturn. The small circle at the right hand side represents the lineal proportion of our globe to those stupendous arches, so that the eye may easily perceive that hundreds of worlds such as ours could be enclosed within such expansive rings. Fig. 94 represents the proportion which the sun bears to the planet Jupiter, the largest planetary orb in the system. The large circle represents the sun, and the small circle Jupiter. If the earth were to be represented on the same scale, it would appear like a point

scarcely perceptible. It is chiefly by the aid of such tangible representations that the mind can form any idea approximating to the reality of

Fig. 93.

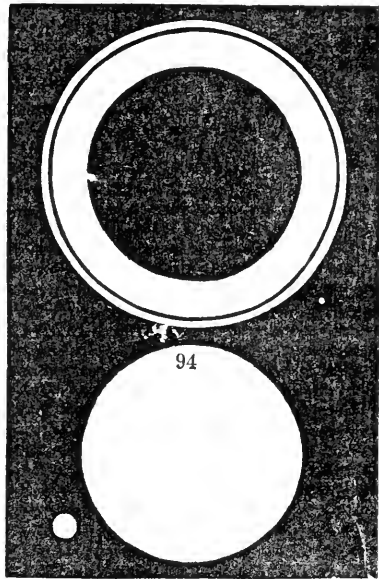

such magnitudes and proportions; and, after all its efforts, its views of such stupendous objects are exceedingly imperfect and obscure.

## CHAPTER VII.

### ON THE METHOD BY WHICH THE DISTANCES AND MAGNITUDES OF THE HEAVENLY BODIES ARE ASCERTAINED.

THERE is a degree of skepticism among a certain class of readers in regard to the conclusions which astronomers have deduced respecting the distances and magnitudes of the celestial bodies. They are apt to suspect that the results they have deduced are *merely conjectural*, and that it is impossible for human beings to arrive at anything like certainty, or even probability, in regard to distances so immensely great, and to magnitudes so far surpassing everything we see around us on this globe. Hence it is that the assertions of astronomers as to these points are apt to be called in question, or to be received with a certain degree of doubt and hesitation, as if they were beyond the limits of truth or probability. And hence such persons are anxious to inquire, "How can astronomers find out such things?" "Tell us by what methods they can measure the distances of the planets and determine their bulks?" Such questions, however, are more easily proposed than answered; not from any difficulty in stating the principles on which astronomers proceed in their investigations, but from the impossibility, in many instances, of conveying an idea of these principles to those who are ignorant of the elements of

geometry and trigonometry. A very slight acquaintance with these branches of the mathematics, however, is sufficient to enable a person to understand the mode by which the distances of the heavenly bodies are determined; but a certain degree of information on such subjects is indispensably requisite, without which no satisfactory explanation can be communicated.

In offering a few remarks on this subject, I shall, in the first place, state certain considerations, level to the comprehension of the general reader, which prove that the celestial bodies are much more distant from the earth, and, consequently, much larger than they are generally supposed to be by the vulgar, and those who are ignorant of astronomical science; and, in the next place, shall give a brief view of the mathematical principles on which astronomers proceed in their calculations.

When a common observer views the heavens for the first time, previous to having received any information on the subject, he is apt to imagine that the sun, moon, and stars are placed in the canopy of the sky at nearly the same distance from the earth, and that this distance is only a little beyond the region of the clouds; for it is

impossible, merely by the eye, to judge of the relative distances of such objects. Previous to experience, it is probable that we could form no correct idea of the relative distances of any objects whatever. The young man who was born blind, and who was restored to sight at the age of thirteen, and who was operation performed by Mr. Cheselden, could form no idea of the distances of the new objects presented to his visual organs. He supposed everything he saw touched his eyes, in the same manner as everything he felt touched his skin. An object of an inch diameter placed before his eyes, which concealed a house from his sight, appeared to him as large as the house. What he had judged to be round by the help of his hands he could not distinguish from what he had judged to be square; nor could he discern by his eyes whether what his hands had perceived to be above or below was really above or below; and it was not until after two months that he could distinguish pictures from solid bodies. In like manner we are apt to be deceived in our estimate of the distances of objects by the eye, particularly of those which appear in the concave of the heavens; and reason and reflection must supply the deficiency of our visual organs before we can arrive at any definite conclusions respecting objects so far beyond our reach.

That the heavenly bodies, particularly the sun, are much greater than they appear to the vulgar eye, may be proved by the following consideration: When the sun rises due east in the morning, his orb appears just as large as it does when he comes to the meridian at midday. Yet it can be shown that the sun, when he is on our meridian, is about 4000 miles nearer us than when he rose in the morning. This may be illustrated by the following figure.

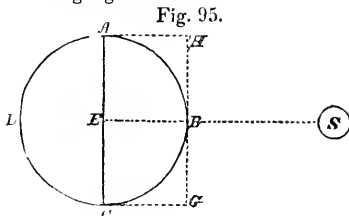

Let *A B C D* represent the earth, and *S* the sun at the point of his rising. Suppose the line *A E C* to represent the meridian of a certain place, and *A* or *E* the place of a spectator. When the sun, in his apparent diurnal motion, comes opposite the meridian *A C*, he is a whole semidiameter of the earth nearer the spectator at *E* than when he appeared in the eastern horizon. This semidiameter is represented by the lines *A H, E B, C G*, and is equal to 3965 miles. Now were the sun only four thousand miles distant from the earth, and consequently, eight thousand miles from us at his rising, he would be nearly four thousand miles nearer us when on the meridian than at his rising; and, consequently, he would appear twice the diameter, and four times as large in surface as he does at the time of his rising. But observation proves that there is no perceptible difference in his apparent magnitude in these different positions; therefore the sun must be much more distant from the earth than four thousand miles. If his distance were only 120,000 miles, his apparent diameter would appear 1-30th part broader when on the meridian than at

the time of his rising, and the difference could easily be determined; but no such difference is perceptible; therefore the sun is still more distant than one hundred and twenty thousand miles.— And, as the *real* size of any body is in proportion to its distance, compared with its *apparent* size, the sun must, from this consideration alone, be more than 1200 miles in diameter, and must contain more than nine hundred millions of cubical miles. But how much greater his distance and magnitude are than what is now stated cannot be determined from such observations.

The same idea may be illustrated as follows: Suppose a spectator at Edinburgh, which may be represented by the point *A* (Fig. 95), and another at Capetown, in the southern extremity of Africa, about the time of our winter solstice, which position may be represented by the point *E*; both spectators might see the sun at the same moment, and he would appear exactly of the same size from both positions. Yet such spectators would be more than 4000 miles distant from each other in a *straight line*, and the observer at Capetown would be several thousands of miles nearer the sun than the one at Edinburgh. Now if the sun were only a few thousands of miles from the earth, he would appear of a very different magnitude to observers removed so far from each other which is contrary to fact. Consequently, the sun must be at a very great distance from the earth, and his real size proportionable to that distance. For experience proves that objects which are of great magnitude may appear comparatively small when removed from us to a great distance. The lofty vessel, as it recedes from the coast toward the ocean, gradually diminishes in its apparent size, until at length it appears as a scarcely distinguishable speck on the verge of the horizon, and the aeronaut with his balloon, when they have ascended beyond the region of the clouds, appear only as a small dusky spot on the canopy of the sky, and sometimes entirely disappear.

The following argument, which is level to the comprehension of every reflecting mind, proves that the sun is larger than the whole globe of the earth, and that the moon is considerably less. Previous to the application of the argument to which I allude, it may be proper to illustrate the

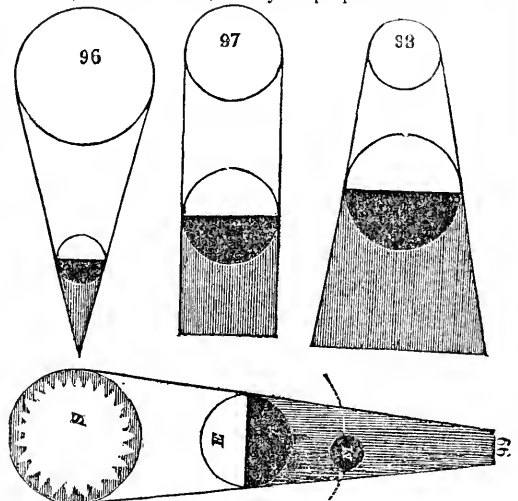

law of shadows. The law by which the shadows of globes are projected is as follows: When the luminous body is larger in diameter than the



opaque body, the shadow which it projects converges to a point which is the vertex of a cone, as in Fig. 96. When the luminous and the opaque body are of an equal size, the shadow is cylindrical, and passes on from the opaque body to an indefinite extent, as represented in Fig. 97. When the luminous body is less than the opaque, the shadow extends in breadth beyond the opaque body, and grows broader and broader in proportion to its distance from the opaque globe, as in Fig. 98. This may be illustrated by holding a ball three or four inches in diameter opposite to a candle, when the shadow of the ball will be seen to be larger in diameter in proportion to the distance of the wall or screen on which the shadow is projected. Now it is well known, and will readily be admitted, that an eclipse of the moon is caused by the shadow of the earth falling upon the moon, when the sun, earth, and moon are nearly in a straight line with respect to each other; and that an eclipse of the sun is caused by the shadow of the moon falling upon a certain portion of the earth. Let *S* (Fig. 99) represent the sun; *E*, the earth; and *M*, the moon, nearly in a straight line, which is the position of these three bodies in an eclipse of the moon. The shadow of the earth, at the distance of the moon, is found to be of a less diameter than the diameter of the earth. This is ascertained by the time which the moon takes in passing through the shadow. The real breadth of that shadow, at the moon's distance from the earth, is about 5900 miles, sometimes more and sometimes less, according as the moon is nearer to or farther from the earth; but the diameter of the earth is nearly 8000 miles; therefore the shadow of the earth gradually decreases in breadth in its progress through space, and, by calculation, it is found that it terminates in a point, as in Fig. 96, at the distance of about 850,000 miles. But when a luminous globe causes the shadow of an opaque globe to converge toward a point, as in Fig. 96, the luminous body must be larger in diameter than the opaque one. The sun is the luminous body which causes the earth to project a shadow on the moon; this shadow, at the moon, is less in breadth than the diameter of the earth; therefore it inevitably follows that the sun is larger than the earth; but how much larger cannot be determined from such considerations.

From the same premises it necessarily follows that the moon is less than the earth. For the moon is sometimes completely covered by the shadow of the earth, although this shadow is less than the earth's diameter, and not only so, but sometimes takes an hour or two in passing through the shadow. If the sun were only equal to the earth in size, the earth's shadow would be projected to an indefinite extent, and be always of the same breadth, and might sometimes eclipse the planet Mars when in opposition to the sun. If the sun were less than the earth, the shadow of the earth would increase in bulk the farther it extended through space (as represented in Fig. 98), and would eclipse the great planets Jupiter, Saturn, and Uranus, with all their moons, when they happened to be near their opposition to the sun; and in this case they would be deprived of the light of the sun for many days together. In such a case, too, the sun would sometimes be eclipsed to the earth by the planet Venus, when in its inferior conjunction with that luminary: an eclipse which might cause a total darkness of several hours' continuance. In short, if the sun were less than any one of the planets, the system would be thrown into confusion by the shadows

of all these bodies increasing in proportion to their distance, and interrupting, periodically, for a length of time, the communications of light and heat. But as none of these things ever happen, it is evident that the sun is much larger than the whole terraqueous globe.

All that requires to be taken for granted by the unlearned reader in this argument is, that the earth is a globular body; that an eclipse of the moon is caused by the shadow of the earth falling upon that orb; and that the shadow of the earth, at the distance of the moon, is of less breadth than the earth's diameter. The first two positions will readily be admitted; and the third position, respecting the breadth of the earth's shadow, may be received on the ground of what has been above stated, and on the authority of astronomers. For, if they were ignorant of this circumstance, they could not calculate eclipses with so much accuracy as they do, and predict the precise moment of the beginning and end of a lunar eclipse

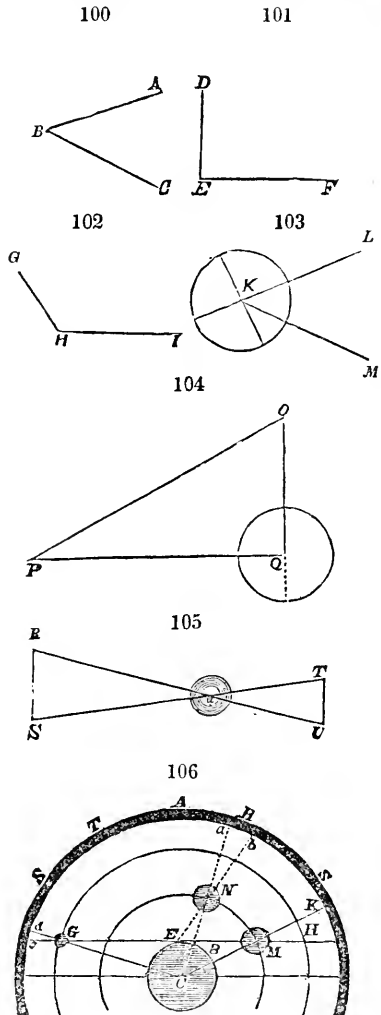

If, then, any individual is convinced, from the consideration above stated, that the sun must be much larger than the earth, he has advanced one step in his conceptions of the magnificence of the

heavenly bodies, and may rest with confidence on the assertions of astronomers in reference to the *real* distances and magnitudes of these orbs, although he may not be acquainted with the mathematical principles and investigations on which their calculations proceed.

Before proceeding to the illustration of the trigonometrical principles on which astronomers proceed in determining the true distances of the heavenly bodies, it may be requisite, for the unlearned reader to give a description of the nature of angles and the mode by which they are measured. An angle is the opening between any two lines which touch each other in a point; and the width of the opening determines the extent of the angle, or the number of degrees or minutes it contains. Thus if we open a pair of compasses, the legs of which may be represented by  $AB, BC$ , Fig. 100, an angle is formed of different dimensions, according as the extremities of the legs are removed farther from or brought nearer to each other. If the legs are made to stand perpendicular to each other, as in Fig. 101, the angle is said to be a *right angle*, and contains ninety degrees, or the fourth part of a circle. The walls of a room generally stand at right angles to the floor. If the legs be separated more than a right angle, they form what is termed an *obtuse angle*, as in Fig. 102. When the angle is less than a right angle, it is called an *acute angle*, as in Fig. 100, and, consequently, contains a less number of degrees than ninety. All angles are measured by the arc of a circle described on the angular point; and every circle, whether great or small, is divided into 360 equal parts, called degrees. Thus, if I want to know the quantity of an angle at  $K$ , (Fig. 103) I place one point of the compasses at the angular point  $K$ , and describe the arc of a circle between the two sides  $LK, KM$ , and whatever number of degrees of a circle is contained between them is the quantity or measure of the angle. If, as in the present case, the angle contains the eighth part of a circle or half a right angle, it is said to be an angle of forty-five degrees. A *triangle* is a figure which contains three angles and three sides, as  $OPQ$ , Fig. 104. It is demonstrated by mathematicians, that the three angles of every triangle, whatever proportion these angles may bear to each other, are exactly equal to two right angles, or 180 degrees. Thus, in the triangle  $OPQ$ , the angle at  $Q$  is a right angle, or ninety degrees, and the other two angles,  $O$  and  $P$ , are together equal to ninety degrees; so that, if one of these angles be known, the other is found by subtracting the number of degrees in the known angle from ninety. Thus, if the angle at  $P$  be equal to thirty degrees, the angle at  $O$  will be equal to sixty degrees. Hence, if any two angles of a triangle be known, the third may be found by subtracting the sum of the two known angles from 180 degrees, the remainder will be the number of degrees in the third angle. All the triangles have their greatest sides opposite to their greatest angles; and if all the angles of the triangle be equal, the sides will also be equal to each other.

If any three of the six parts of a triangle be known (excepting the three angles) all the other parts may be known from them. Thus, if the side  $PQ$ , and the angles at  $P$  and  $Q$  be known, we can find the length of the sides  $PO$  and  $OQ$ . It is on this general principle that the distances and magnitudes of the heavenly bodies are determined.

In order to understand and apply this principle, it is necessary that we explain the nature of a

*parallax*. A parallax denotes the change of the apparent place of any heavenly body, caused by being seen from different points of view. This may be illustrated by terrestrial objects as follows: Suppose a tree 40 or 50 yards distant from two spectators, who are 15 or 20 yards distant from each other; the one will perceive the tree in a line with certain objects near the horizon, which are considerably distant from those which appear in the direction of the tree, as viewed from the station occupied by the other spectator. The difference between the two points near the horizon where the tree appears to coincide to the two different spectators is the *parallax* of the object. If the tree were only 20 or 25 yards distant, the parallax would be twice as large; or, in other words, the points in the horizon where it was seen by the two spectators would be double the distance, as in the former case; and if the tree were two or three hundred yards distant, the parallax would be proportionably small. Or, suppose two persons sitting near each other at one side of a room, and a candle placed on a table in the middle of the room, the points on the opposite wall where the candle would appear to each of the two persons would be considerably distant from each other; and this distance may be called the *parallax* of the candle as viewed by the two observers. This may be illustrated by Fig. 105, where  $R$  and  $S$  may represent the positions of the observers;  $a$  the candle or tree; and  $T$  and  $U$  the points on the opposite wall or in the horizon where the candle or the tree appears to the respective observers. The observer at  $R$  sees the intermediate object at  $U$ ; and the one at  $S$  sees it in the direction  $ST$ . The angle  $RaS$ , which is equal to the angle  $TaU$ , is called the angle of parallax, which is the difference of position in which the object is seen by the two observers. If, then, the distance between the observers  $RS$  be known, and the quantity of the angle  $RaS$ , the distance between the observers and the object can also be known by calculation.

Let us now apply this principle to the heavenly bodies. In Fig. 106 let the semicircle  $S, T, A, R, S$ , represent a section of the concave of the heavens; the middle circle,  $EC$ , the earth;  $M$ , the moon;  $C$ , the center of the earth; and  $EH$ , the sensible horizon of a spectator at  $E$ . It is evident that if the moon be viewed from the earth at the point  $E$ , she will be seen in the horizon at the point  $H$ ; but were she viewed at the same time from  $C$ , the center of the earth, she would appear among the stars at the point  $K$ , in a more elevated position than when seen from the surface of the earth at  $E$ . The difference between these two apparent positions of the moon, or the angle  $KMH$ , is called the moon's *horizontal parallax*. Astronomers know from calculation in what point of the heavens the moon would appear as viewed from the earth's center; and they know from actual observation where she appears as viewed from the surface; and, therefore, can find the difference of the two positions, or the angle of parallax. This angle might likewise be found by supposing two spectators on different parts of the earth's surface viewing the moon at the same time. Suppose a spectator at  $E$ , who sees the moon in the horizon at  $H$ ; and another observer, on the same meridian, at  $B$ , who sees her in his zenith at  $K$ ; the parallax, as formerly, will be  $KH$ .

The parallax of a heavenly body decreases in proportion to its altitude above the horizon, and at the zenith ( $A$ ) it is nothing, for the line from the center of the earth coincides with that from the surface, as  $CEA$ . Thus the parallax of the moon at  $N$  ( $a b$ ) is less than the horizontal parallax

*K H*; but from the parallax observed at any altitude, the horizontal parallax can be deduced; and it is from this parallax that the distance of the moon or any other heavenly body is determined. *The greater the distance of any body from the earth, the less is its parallax.* Thus the heavenly body *G*, which is farther from the earth than the moon, has a less parallax (*c d*) than that of the moon, *K H*.

Now the parallax of the moon being known, it is easy to find the distance of that orb from the earth; for in every triangle, if one side and two angles be known, the other angle and the other two sides can also be found. In the present case, we have a triangle *E M C*, in which the side *E C*, or the semidiameter of the earth, is known. The angle *M E C* is a right angle, or ninety degrees; and the parallactic angle *E M C* is supposed to be found by observation. From these data, by an easy trigonometrical calculation, the length of the side *C M*, or the distance of the moon from the center of the earth, can be determined with the utmost precision, provided the angle of parallax has been accurately ascertained.

Before proceeding to illustrate by examples the method of calculating the distances of the heavenly bodies when the parallax is found, I shall present an example or two of the mode of computing the heights and distances of terrestrial objects, the principle on which we proceed being the same in both cases. Suppose it were required to find the height of the tower *C B* (Fig. 107), we first measure the distance from the bottom of the tower, *B*, to a station at the point *A*, which suppose to be one hundred feet. From this station, by a quadrant or other angular instrument, we take the angle of elevation of the top of the tower, or the angle *C A B*, which suppose to be forty-seven and a half degrees. Here we have a triangle in which we have one side, *A B*, and two angles; namely, the angle at *A*= $47\frac{1}{2}^\circ$ , and the angle at *B*, which is a right angle, or  $90^\circ$ , as the tower is supposed to stand perpendicular to the ground; therefore, the side *C B*, which is the height of the tower, can be found, and likewise the other side, *A C*, if required. To find *C B*, the height of the tower, we make *A B* the radius of the circle, a portion of which measures the angle *A*; and the side *B C*, or the height of the tower, becomes the tangent of that angle. And as there is a certain known proportion between the radius of every circle and the tangent, the height of the tower will be found by the following proportion: As the radius: is to the tangent of the angle *A*,  $47\frac{1}{2}^\circ$ : so is the side *A B*, 100 feet: to *C B*, the height of the tower= $109\frac{1}{8}$  feet. The following is the calculation by logarithms:

Logarithm of the 2d term—	
Tangent of $47\frac{1}{2}^\circ$ .....	10.0379475
Logarithm of <i>A B</i> =100 feet—	
3d term.....	2.0000630
	<hr/>
	12.0379475
Logarithm of radius—1st term.....	10.0000000
	<hr/>
Logarithm of <i>C B</i> , 4th term=	
$109\frac{1}{8}$ feet.....	2.0379475

By this calculation the height of the tower is found with the greatest nicety, provided the measurement of the side *A B*, and the angle *A*, have been taken with accuracy.

Again: Suppose it were required to measure the distance between a tree *E*, and a house *D*, on the opposite side of a river. We first measure a space

from *E* to *F* (Fig. 108), suppose 200 yards, in a right line, and then find the angles *E* and *F* at each end of this line. Suppose the angle at *E* to be seventy-three degrees and the angle at *F* sixty-eight degrees. As all the angles of a triangle are equal to two right angles, or  $180^\circ$ , if we add these two angles and subtract their sum from  $180^\circ$ , the remainder,  $39^\circ$ , will be the measure of the angle at *D*.

It is a demonstrated proposition in trigonometry, that in any plane triangle, the sides are in the same proportion as the sines of the opposite angles. A sine is a line drawn through one extremity of an arc perpendicular upon the diameter or radius passing through the other extremity, as *ad* (Fig. 107).

In order, then, to find the distance (*E D*) between the tree and the house on the other side of the river, we state the following proportion: As the sine of *D*,  $39^\circ$ , the angle opposite to *E F*, the known side: is to the sine of the angle *F*,  $68^\circ$ , opposite the side sought, *E D*: so is the length of the line *E F*=200 yards: to the distance, *E D*, between the tree and the house= $294\frac{1}{2}$  yards. The following is the operation by logarithms:

2d term—Sine of angle, <i>F</i> = $68^\circ$	9.9671659
3d term— <i>E F</i> =200 yards. Log.	2.3010300
	<hr/>
1st term—Sine of angle, <i>D</i> = $39^\circ$	12.2681959
	9.7988718
	<hr/>
4th term— <i>D E</i> = $294\frac{1}{2}$ yards=	2.4693241

In these examples the logarithms of the second and third terms of the proportion are added, and from their sum the logarithm of the first term is subtracted, which leaves the logarithm of the fourth term; as in common numbers, the second and third terms are multiplied together, and their product divided by the first term; addition of logarithms corresponding to multiplication of whole numbers, and subtraction to division. The logarithms of common numbers, and of sines and tangents, are found in tables prepared for the purposes of calculation.

I shall now state an example or two in reference to the celestial bodies. Suppose it is required to find the distance of the moon from the earth. In Fig. 109, let *E C* represent the earth;

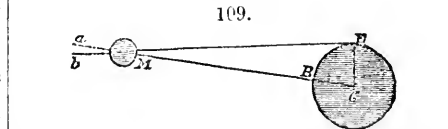

*M*, the moon; *E*, the place of a spectator observing the moon in his sensible horizon; *E M b* and *C M a* the direction of the moon as seen from

the center of the earth at *C*, or from its surface at *B*; *a* the place of the moon as seen from the center, and *b* its place as seen from the surface at *E*; or, in other words, the moon's *horizontal parallax*. This parallax, at the moon's mean distance from the earth, is found to be 57 minutes, 5 seconds. Here, then, we have a triangle, *CEM*, of which we have one side and two angles given. The side given is the semidiameter of the earth, *EC*, which is equal to 3965 miles; the angle at *E* is a right angle, or ninety degrees, for it forms a tangent to the circle at *E*; the angle at *M* is the horizontal parallax, which is found by observation. From these data, the side *MC*, or the distance of the moon from the center of the earth, may be easily found. If we make *CM* radius, *EC* will be the sine of the angle *M*; and the distance of the moon is found from the following proportion: As *EC*, the sine of fifty-seven minutes, five seconds: is to 3965, the number of miles in the semidiameter of the earth:: so is *MC*, the radius: to a fourth number, 238,800=*MC*=the distance of the moon from the center of the earth.

2d term—3965=the earth's semidiameter	3.598243
3d term—Radius . . . . .	10.000000
	13.598243
1st term—Sine of 57 minutes, 5 seconds	8.220215
<i>MC</i> , distance of the moon, 238,800 miles=	5.378028

According to this calculation, the moon is two hundred and thirty-eight thousand, eight hundred miles from the earth. In round numbers we generally say that the moon is 240,000 miles distant; and, in point of fact, she is sometimes considerably more than 240,000 miles distant, and sometimes less than the number above stated, as she moves in an elliptical orbit, her horizontal parallax varying from 54 to above 60 minutes.

To find the Diameter of the Moon.—In Fig. 110 let *AGB* represent the moon, and *C* an observer at the earth. The apparent diameter of the moon at its mean distance, as measured by a micrometer, is 31 minutes, 26 seconds, represented by the angle *ACB*; the half of this, or the angle formed by the semidiameter of the moon, *ACG*, is 15 minutes, 43 seconds. The distance of the moon, *GC*, is supposed to be found as above stated,

110.



namely, 238,800 miles. Here, then, we have the angle *CA G*, which is a right angle, and the angle *AC G*=15' 43", which is found by observation; and the side *CG*, or the distance of the moon from the earth. We can therefore find the side *AG*, or the semidiameter of the moon, by the following proportion: As radius: is to *CG*, the distance of the moon, 238,800 miles:: so is the sine of *AC G*, 15' 43": to the number of miles contained in the moon's semidiameter, *AG*=1091½, which, being doubled, gives 2183 miles as the diameter of the moon.

2d term— <i>CG</i> =238,800—Log.	5.378028
3d term—Sine of <i>AC G</i> , 15' 43"	7.660059
	13.038087
1st term—Radius . . . . .	10.000000
Semidiameter of the moon, 1,091½=	2.303808
	2
Diameter of the moon=	2,183

Such is the general mode by which the distances and magnitudes of the heavenly bodies are calculated. I am aware that the general reader who is unacquainted with the principles of trigonometry, may find a little difficulty in comprehending the statements and calculations given above; but my design simply was to convey an idea of the principle on which astronomers proceed in their computations of the distances and bulks of the celestial orbs, and to excite those who are anxious to understand the subject, to engage in the study of plane trigonometry, a study which presents no great difficulty to any one who is already a proficient in common arithmetic. I conclude the subject with the following

*General Remarks.*—1. Before the bulks of the heavenly bodies can be determined, their distances from the earth must first be ascertained. When their distances are found, it is quite an easy matter to determine their real bulks from their apparent magnitudes. 2. The semidiameter of the earth forms the groundwork of all our calculations respecting the distances of the celestial orbs. Were we ignorant of the dimensions of the earth, we could not find the real distance and magnitude of any heavenly body; and it is owing to the comparatively small diameter of the earth that it becomes difficult in some cases to determine with accuracy the parallaxes of certain heavenly bodies. Were we placed on a planet such as Jupiter, whose diameter is more than eleven times that of our globe, it would be much more easy to find the parallaxes of the sun and planets. The parallaxes of Jupiter's moons, as observed from that planet, will form pretty large angles and be easily perceptible; and so likewise will be the parallaxes of the sun and the other planets which are visible from that globe. 3. The chief difficulty in finding the distances of the heavenly bodies is to determine accurately the precise quantity of their parallaxes. In the case of the moon there is no difficulty, as her horizontal parallax amounts to nearly one degree, and can be taken with the greatest nicety; but the sun's parallax is so small that it was some time before it was accurately determined. It was for this purpose, among others, that Captain Cook's first expedition to the Pacific Ocean was undertaken, in order that the astronomers connected with it might observe the transit of Venus at the Island of Tahiti; since which time the sun's distance has been ascertained within the one eighty-seventh part of his true distance, which likewise determines very nearly the true proportional distance and magnitudes of all the planets. This circumstance accounts for the fact, that in books of astronomy published about a century ago, the distances and magnitudes of the sun and planets are estimated somewhat lower than they are now found to be, the improvements which have been made in the construction of astronomical instruments having enabled modern observers to measure parallactic angles with greater niceness and accuracy. 4. When the parallax of any heavenly body is once accurately found, and its

apparent diameter measured, its real distance and bulk can be as certainly known as the price of any quantity of merchandise which is calculated by the rule of proportion. 5. From what has been stated above, we may learn the importance of knowing all the properties of a triangle, and the art of measuring angles. At first sight it may appear to be a matter of trivial importance to know that the radius of a circle bears a certain known proportion to the sine or tangent of a certain angle; that the *sides* of any triangle are in the same proportion as the *sines* of the opposite angles; and that the three angles of every plane triangle are exactly equal to two right angles.— Yet such truths form the foundation of all the discoveries which have been made respecting the magnitudes and distances of the great bodies of the universe, and of the ample conceptions we are now enabled to form of the vast extent of creation, and of the attributes of its adorable Creator.

Those persons who feel themselves unable to comprehend clearly the principles and calculations above stated, may rest satisfied with the general deductions of astronomers respecting the distances and magnitudes of the sun and planets, from the following considerations: 1. *The general agreement of all modern astronomers as to these deductions.* However much astronomers may differ in regard to certain subordinate opinions or conjectures respecting certain phenomena, they all agree with respect to the bulks and distances of the planetary orbs, and the mode by which they are ascertained. If there were any fallacy in their calculations, such is the tendency of human nature to find fault, it would soon be pointed out.—

2. *The consideration of the accuracy with which astronomers predict certain celestial phenomena should induce persons unskilled in this science to rely on the conclusions deduced by astronomers.* They are fully aware that the eclipses of the sun and moon are calculated and predicted with the utmost accuracy. The very moment of their beginning, middle, and end, and the places where they will be visible, are fore-told to a nicety; the nature and magnitude of the eclipse, and all the circumstances connected with it, determined; and that, too, for more than a century to come. All the eclipses which have happened of late years were calculated more than half a century ago, and are to be found recorded in the writings of astronomers. They can likewise tell when Mars, Jupiter, or Saturn is to suffer an occultation by the moon, the time when it will begin and end, the particular part of the moon's limb behind which the planet will disappear, the point on the opposite limb where it will again emerge, and the places of the earth where the occultation will be visible. They can likewise predict the precise moment when any of the fixed stars—even those invisible to the naked eye—shall suffer an occultation by the moon or by any of the planets; and such occultations of the stars and planets are stated in the "Nautical Almanac," and similar publications, three or four years before they actually happen.

The precise time, likewise, when the planets Mercury and Venus will appear to pass across the sun's disc, has been predicted for a century before such events happened, and such transits have been calculated for several centuries to come, and will most assuredly take place, as they have hitherto done, if the laws of nature continue to operate as in ages past. Dr. Halley, in 1691, predicted the transit of Venus that happened in 1761, seventy years before it took place; and not only so, but

he calculated the precise hour in which the planet would appear to touch the limb of the sun as seen from different places; the particular part of the sun's margin where the planet would appear and disappear, and the precise course it would take in passing across the disc of the sun; the appearance it would present in different regions of the globe, and the most proper places in both hemispheres were pointed out where either its beginning, middle, or end would be most distinctly observed, in order to accomplish the object in view; namely, the determination of the exact distance of the sun. All which calculations and predictions were ultimately found to be correct; and astronomers were sent to different parts of the globe to observe this interesting phenomenon, which happens only once or twice in the course of a century. The same astronomer calculated the period of a comet, distinguished by the name of "Halley's Comet," and predicted the periods when it would return. It was seen in England in 1682, and Dr. Halley calculated that it would again appear in this part of the system in 1758; and it accordingly made its appearance in December, 1758, and arrived at its perihelion on the 13th of March, 1759. The validity of these calculations and predictions has been again verified by the reappearance of the same comet in 1835, just at the time when it was expected, which proves that it completes its course in the period which had been predicted, namely, seventy-six years, and will, doubtless, again revisit this part of the system in the year 1911 or 1912. Astronomers can likewise point out, even in the day-time, the different stars and planets which are above the horizon, though invisible to the unassisted eye. I have sometimes surprised even gentlemen of intelligence by showing them, through an equatorial telescope, the star *Arcturus*, and, in a minute or two afterward, the star *Allair* in another part of the heavens, and the planet *Venus* in another quarter in the form of a brilliant crescent, while the sun was several hours above the horizon, and shining in its greatest brightness, and while these bodies are every moment shifting their apparent positions; all which is quite easy to be accomplished by every one who understands the motions of the heavenly bodies and the first principles of astronomy.

Now as the above facts are indisputable, and every one who feels an interest in the subject may satisfy himself as to their reality, it is evident to a demonstration that the principles of science on which such calculations and predictions proceed are not mere conjectures or precarious suppositions, but have a real foundation in the constitution of nature and in the fundamental laws which govern the universe. And as the knowledge of astronomers cannot be questioned in relation to the phenomena to which I refer, it would be unreasonable, and injurious to the moral characters of such men, to call in question their modes of ascertaining the distances of the sun and the planetary bodies, and the deductions they have made in relation to their astonishing magnitudes. There is no science whose principles are more certain and demonstrable than those of astronomy. No labor or expense has been spared to extend its observations, and to render them accurate in the extreme; and the noblest efforts of genius have been called forth to establish its truths on a basis immutable as the laws of the universe; and, therefore, the man who questions the leading facts and deductions of this science only proclaims his own imbecility and ignorance.

## CHAPTER VIII.

### ON THE SCENERY OF THE HEAVENS, AS VIEWED FROM THE SURFACES OF THE DIFFERENT PLANETS AND THEIR SATELLITES.

THIS is a department of descriptive astronomy which is seldom noticed in books professedly written to illustrate the objects of this science. It is here introduced not only as an interesting subject of contemplation, but as an illustration of the *variety* which the Creator has introduced into the scenes of the universe, and as a collateral or presumptive argument in support of the doctrine of a plurality of worlds.

Before proceeding to the particular descriptions I intend to give, it may be proper to state the following *General Remarks*: 1. The different clusters of stars or the *constellations* will appear exactly the same when viewed from the other planets as to the inhabitants of our globe. For example, the constellations of *Orion* and of the *Great Bear* will appear of the same shape or figure, and all the stars of which they are composed will appear to have the same arrangement and the same relative distances from each other and from neighboring stars, as they do to us. 2. The *apparent magnitudes* of the fixed stars will appear exactly the same as they do when viewed from our world; that is, they will appear no larger than shining points of different magnitudes, even when viewed from the most distant planets. The reason of this and of the preceding position is obvious from the consideration of the *immense distance* of those bodies; for although we are 190 millions of miles nearer some of the fixed stars at one time of the year than at another, yet there appears no sensible difference in their size or arrangement, and although we were placed on the remotest planet of the system, we have no reason to believe that any material difference in this respect would be perceived; for the distances of the remoter planets bear no sensible proportion to the distances of the fixed stars. Even the distance of the planet *Uranus*, great as it is, which would require four hundred years for a cannon ball to move over the space which intervenes between that orb and us, is less than the ten-thousandth part of the distance of the nearest star; and, therefore, can produce no sensible difference in the general aspect of the starry firmament. 3. Though the general arrangement of the stars and constellations will appear the same as to us, yet the different directions of the axes of some of the planets from that of the earth will cause a *different appearance in their apparent diurnal revolutions*. Some stars which appear in our equator may, in other planets, appear near one of their poles, and our pole star may appear near their equator.

In the following descriptions it is taken for granted that the general laws of vision are materially the same in all the planetary bodies as in that part of the system which we occupy. Of this we have no reason to doubt, as the same identical light which illuminates the earth likewise enlightens all the planets and their satellites. It originates from the same source, it is refracted

and reflected by the same laws, and must produce colors similar or analogous to those which diversify the surface of our globe; though, perhaps, susceptible of numerous modifications in other regions, according to the nature of the atmospheres through which it passes, and the quality of the objects on which it falls. The descriptions that follow likewise proceed on the supposition that the *extent of vision* is the same as ours. This in all probability, is not the case. It is more probable that, in certain worlds, the organs of vision of their inhabitants may be far more exquisite than ours, and capable of surveying with distinctness a much more extensive range of view. But as we are ignorant of such particulars, we can only proceed on the assumption of what would appear to eyes constituted like ours were we placed on the surfaces of the different planets.

*Scenery of the Heavens from the Planet Mercury*.—This planet being so near the sun has prevented us from discovering various particulars which have been ascertained in relation to several of the other planets; and, therefore, little can be said respecting its celestial scenery. The starry heavens will appear to move around it every twenty-four hours, as they do to us, if the observations of M. Schroeter, formerly stated (p. 27) be correct; but the direction of its axis of rotation is not known, and, therefore, we cannot tell what stars will appear near its equator or its poles. The sun will present a surface in the heavens seven times as large as he does to us, and, of course, will exhibit a very august and brilliant appearance in the sky, and will produce a corresponding brightness and vividness of color on the objects which are distributed over the surface of the planet. Both *Venus* and the earth will appear as *superior* planets; and when *Venus* is near its opposition to the sun, at which time it will rise when the sun sets, it will present a very brilliant appearance to the inhabitants of *Mercury*, and serve the purposes of a small moon, to illuminate the evenings in the absence of the sun. As *Venus* presents a full enlightened hemisphere at this period to the inhabitants of *Mercury*, it will exhibit a surface six or seven times larger than it does to us when it shines with its greatest brilliancy, and, therefore, will appear a very bright and conspicuous object in the firmament of this planet. At all other times it will appear at least two or three times larger than it ever does as seen from the earth. It will generally appear round, but at certain times it will exhibit a gibbous phase, as the planet *Mars* frequently does to us. It will never appear to the inhabitants of *Mercury* in the form of a crescent or half moon, as it sometimes does through our telescopes. There is no celestial body within the range of this planet with which we are acquainted which will exhibit either a half moon or a crescent phase unless it be accompanied with a satellite. The

earth is another object in the firmament of Mercury which will appear next in splendor to Venus. The earth and Venus are nearly of an equal size, Venus being only 130 miles less in diameter than the earth; but the earth being nearly double the distance of Venus from Mercury, its apparent size, at the time of its opposition to the sun, will be only about half that of Venus. The earth, however, at this period, will appear in the sky of Mercury of a size and splendor three or four times greater than Venus does to us at the period of its greatest brilliancy. Our moon will also be seen like a star accompanying the earth, sometimes approaching to or receding farther from the earth, and sometimes hidden from the view by passing across the disc of the earth or through its shadow. It will probably appear about the size and brightness of Mars or Saturn, as seen in our sky. The earth with its satellite, and Venus, will be seen near the same point of the heavens at the end of every nineteen months, when they will for some time appear the most conspicuous objects in the heavens, and will diffuse a considerable portion of light in the absence of the sun. At other periods, the one will rise in the eastern horizon as the other sets in the western; so that the inhabitants of Mercury will seldom be without a conspicuous object in their heavens, diffusing a luster far superior to that of any other stars or planets. The earth will be in opposition to the sun every four months, and Venus after a period of five months. The planets Mars, Jupiter, and Saturn will appear nearly as they do to us, but with a somewhat inferior degree of magnitude and brilliancy, particularly in the case of Mars. The period of the annual revolution of Mercury being eighty-eight days, the sun will appear to move from west to east through the circle of the heavens at a rate more than four times greater than his apparent motion through the signs of our zodiac.

*Appearance of the Heavens as viewed from Venus.*—To the inhabitants of this planet the heavens will present an aspect nearly similar to that of Mercury, with a few variations. Mercury will be to Venus an *inferior* planet, which will never appear beyond thirty-eight or forty degrees of the sun. It will appear in the evening after sunset for the space of two or three hours when near its elongation, and in the morning before sunrise when in the opposite part of its course, and will alternately be a morning and an evening star to Venus, as that planet is to us, but with a less degree of splendor. The most splendid object in the nocturnal sky of Venus will be the *earth*, when in opposition to the sun, when it will appear with a magnitude and splendor five or six times greater than either Jupiter or Venus appear to us at the time of their greatest brilliancy. It will serve, in a great measure, the purpose of a moon to Venus, if this planet have no satellite, and will cause the several objects on its surface to project distinct and well-defined shadows, as our moon does when she appears a crescent. Our moon, in its revolutions round the earth, will likewise appear a prominent object in the heavens, and will probably appear about the size that Jupiter appears to us. Her occultations, eclipses, and transits across the earth's disc will be distinctly visible. With telescopes such as the best of ours the earth would appear from Venus a much larger and more variegated object than any of the planets do to us when viewed with high magnifying powers. The forms of our different continents, seas, and islands, the different strata of clouds in our atmosphere, with their several changes and motions,

and the earth's diurnal rotation, would, in all probability, be distinctly perceived. Even the varieties which distinguish the surface of our moon would be visible with telescopes of high magnifying power. The circumstances now stated prove the connection of the different parts of the planetary system with one another, and that the Creator has so arranged this system as to render one world, in a certain degree, subservient to the benefit of another. The earth serves as a large and splendid moon to the lunar inhabitants; it serves, in a certain degree, the purpose of a small moon to Mercury; it serves the purpose of a larger moon, by exhibiting a surface and a radiance four times greater to the inhabitants of Venus; and it serves as a morning and an evening star to the planet Mars. So that, while we feel enjoyment in contemplating the moon walking in brightness, and hail with pleasure the morning star as the harbinger of day, and feel a delight in surveying those nocturnal orbs through our telescopes, the globe on which we dwell affords similar enjoyments to the intellectual beings in neighboring worlds, who behold our habitation from afar as a bright speck upon their firmament, diffusing amid the shades of night a mild degree of radiance. From Venus the planets Saturn and Jupiter will appear nearly as they do to us, but the planet Mars will appear considerably smaller. The sun in this planet will present a surface twice as large as he does in our sky, and will appear to make a revolution round the heavens in the course of seven months and a half, which completes the year of Venus.

*The Heavens as viewed from Mars.*—From this planet the earth will at certain periods be distinctly seen, but it will present a different aspect both in its general appearance and its apparent motions from what it does to the inhabitants of Venus. To Mars the earth is an inferior planet, whose orbit is *within* the orbit of Mars. It will therefore, be seen only as a morning and an evening star, as Venus appears to us; but with a less degree of magnitude and brightness, since Mars is at a greater distance from the earth than the earth is from Venus. It will present to Mars successively the form of a *crescent*, a *half-moon*, and a *gibbous* phase, but will seldom or never be seen as a full enlightened hemisphere, on account of its proximity to the sun, when its enlightened surface is fully turned toward the planet; nor will it ever appear farther removed from the sun, either in the mornings or evenings, than forty-eight degrees, so that the earth will never appear in the firmament of Mars about midnight. The earth will likewise be sometimes seen to pass across the sun's disc like a round black spot, as Venus and Mercury at certain periods appear to us; but the planet Mercury will never be seen from Mars on account of its smallness and its nearness to the sun; for at its greatest elongation it will be only a few degrees from the sun's margin, and will consequently be immersed in his rays. The only time in which it might happen to be detected will be when it makes a transit across the solar disc. Venus will be as seldom seen by the inhabitants of Mars as Mercury is to us. Our moon will likewise be seen from Mars like a small star accompanying the earth, sometimes appearing to the east and sometimes to the west of the earth, but never at a greater distance from each other than fifteen minutes of a degree, or about half the apparent breadth of the moon; and with telescopes such as ours all its phases and eclipses might be distinctly perceived. The planets Jupiter and Saturn will appear to Mars nearly as

they do to us. At the time of Jupiter's opposition to the sun that planet will appear a *slight degree* larger, as Mars is then fifty millions of miles nearer it than we are; but Saturn will not appear sensibly larger than to us; and it is likely that the planets Uranus, Vesta, Juno, Ceres and Pallas will not be more distinguishable than they are from our globe. The point *Aries*, on the ecliptic of Mars, or one of the points where its ecliptic and equator intersect each other, corresponds to  $19^{\circ} 25'$  of our sign *Sagittarius*. In consequence of this, the poles of Mars will be directed to points of the heavens considerably different from our polar points, and its equator will pass through a different series of stars from that which marks our equator, which will cause the different stars and constellations in their apparent diurnal revolution to present a different aspect from what they do in their apparent movements round our globe.

*The Heavens, as viewed from Vesta, Juno, Ceres and Pallas.*—These planets, being so very nearly at the same mean distance from the sun, the appearance of the heavens will be nearly the same to the inhabitants [if any] of each of these bodies. The planet Jupiter will be the most conspicuous object in the nocturnal sky of all these planets, and will appear with nearly three times the size and splendor that he does when seen from the earth, so as to exhibit the appearance of a small brilliant moon. Saturn will appear somewhat larger and brighter than to us, but the difference in his appearance will be inconsiderable; nor will Uranus be more distinctly visible than from the earth. At other times, when near their conjunction with the sun, these planets will appear smaller than to us. Mars will sometimes appear as a morning and an evening star, but he will always be in the immediate neighborhood of the sun, and will present a surface much less in apparent size than he does to the earth. The earth will seldom be seen on account of its proximity to the sun; and Venus and Mercury will be altogether invisible, unless when they transit the solar disc. It is likely that, at certain times, the planets Vesta, Juno, Ceres, and Pallas will exhibit an uncommon, and occasionally a brilliant appearance in the firmament of each other. As their distances from the sun are so nearly the same, they may occasionally approach each other so as to be ten times nearer to one another in one part of their course than at another. It is even possible that they might approach within a few miles of each other, or even come into collision. These different positions in which they may be placed in relation to one another will doubtless produce a great variety in the appearances they present in their respective firmaments; so that at one time they may present in the visible firmament a surface a hundred or even two hundred times greater than they do in other parts of their annual revolutions. It is probable, therefore, that the diversified aspects of these planets, in respect to each other, will form the most striking phenomena which diversify their nocturnal heavens. In consequence of the great eccentricity of the orbit of Pallas, the sun will appear much larger to this planet in one part of its revolution than it does at another.

*Celestial Scenery from Jupiter.*—The only planet whose appearance will be conspicuous in the firmament of Jupiter is the planet *Saturn*, which will appear with a surface four times greater than is exhibited in our sky, and will appear larger than either Jupiter or Venus does to us, particularly at the time of its opposition to the sun. At certain

other periods, when near the time of its conjunction with the sun, it will appear considerably smaller than when viewed from the earth; as, at such periods, Saturn is nearly fourteen hundred millions of miles distant from Jupiter, while it is never beyond ten hundred millions from the earth, even at its remotest distance. The planet Uranus, which is scarcely visible to our unassisted sight, will not be much more distinguishable at Jupiter than with us, even at the period of its opposition, although Jupiter is at that time 400,000,000 of miles nearer it than a spectator on the earth. At other times, when near its conjunction with the sun, it will be 2,300,000,000 of miles from Jupiter, which is 400,000,000 of miles more distant than it ever is from us. Mars will scarcely be seen from Jupiter, both on account of his smallness and his proximity to the sun; for at his greatest elevation he can never be more than eighteen degrees from that luminary. The earth, too, will be invisible from Jupiter, both on account of its small size, its distance, and its being in the immediate vicinity of the sun, and immersed in its rays; so that the inhabitants of this planet will scarcely suspect that such a globe as that on which we dwell exists in the universe. It is a humiliating consideration to reflect, that before we have passed over one fourth part of the extent of our system, this earth, with all its kingdoms and fancied grandeur, of which mortals are so proud, vanishes from the sight, as if it were a mere atom in creation, and is altogether unnoticed and unknown. It is calculated to convey a lesson of *humility* and of humanity to those proud and ambitious mortals who glory in their riches, and in the small patches of earthly territory they have acquired at the expense of the blood of thousands of their fellow-men, and who fancy themselves to be a species of demigods, because they have assisted in the conquest of nations, and in spreading ruin and devastation over the earth. Let us wing our flight to Jupiter or Saturn, which appear so conspicuous in our nocturnal sky, and before we have arrived at the middle point of the planetary system this globe on which we tread, with all the proud mortals that dwell upon its surface, vanishes from the sight as a particle of water, with its microscopic animalcule, dropped into the ocean, disappears for ever. In those regions more expansive and magnificent scenes open to view, and their inhabitants, if ever they have heard of such beings as fallen man, look down with an eye of pity and commiseration, and view their characters and conduct with a holy indignation and contempt.

Venus and Mercury will, of course, be altogether invisible from the surface of Jupiter, and it is questionable whether even the planets Vesta, Juno, Ceres, and Pallas will be perceived. But although so few of the primary planets are seen in the nocturnal sky of this planet, its firmament will present a most splendid and variegated aspect by the diversified phases, eclipses, and movements of the satellites with which it is encircled; so that its inhabitants will be more charmed and interested by the phenomena presented by their own moons than by their contemplation of the other bodies of the system. But as I have already described the appearances of the moons, as seen from Jupiter (p. 95, chap. iv, sec. ii.) it is unnecessary to enlarge.

*Scenery of the Heavens as viewed from Saturn.*—The firmament of Saturn will unquestionably present to view a more magnificent and diversified scene of celestial phenomena than that of any other planet of our system. It is placed nearly in the middle of that space which intervenes between



the sun and the orbit of the remotest planet. Including its rings and satellites, it may be considered as the largest body or system of bodies within the limits of the solar system; and it excels them all in the sublime and diversified apparatus with which it is accompanied. In these respects Saturn may justly be considered as the sovereign among the planetary hosts. The prominent parts of its celestial scenery may be considered as belonging to its own system of rings and satellites, and the views which will occasionally be opened of the firmament of the fixed stars; for few of the other planets will make their appearance in its sky. Jupiter will appear alternately as a morning and an evening star, with about the same degree of brilliancy it exhibits to us; but it will seldom be conspicuous except near the period of its greatest elongation, and it will never appear to remove from the sun farther than thirty-seven degrees, and, consequently, will not appear so conspicuous nor for such a length of time, as Venus does to us. Uranus is the only other planet which will be seen from Saturn, and it will there be distinctly perceptible, like a star of the third magnitude, when near the time of its opposition to the sun. But near the time of its conjunction it will be completely invisible, being then eighteen hundred millions of miles more distant than at the opposition, and eight hundred millions of miles more distant from Saturn than it ever is from the earth at any period. All the other eight planets, together with our moon, will be far beyond the reach of a spectator in Saturn, unless he be furnished with organs of vision far superior to ours in their "space-penetrating power." It is not improbable that more comets will be seen in their course from the sun, from the distant regions in which Saturn moves, than from that part of the system in which we are placed. Some of these bodies, when they pass beyond the limits of our view, will be visible beyond the orbit of Saturn; and as their motions in those distant spaces are much slower than when near the sun, they will remain visible for a longer time, when they happen to make their appearance, than they do when passing through our part of the system.

Having already given a pretty full description of the appearance of the rings of this planet as viewed from its surface (p. 63-71), and of the phenomena exhibited by its satellites (p. 98), it is unnecessary to introduce the subject in this place. I shall only remark further, in regard to the rings which encompass this planet, that, beside the light they reflect on the planet, and the brilliant aspect they present in its firmament, they cast a great diversity of shadows upon the surface of the planet, of different breadths at different times and places, and it will require a considerable degree of attention and investigation on the part of its inhabitants to determine whence the shadows proceed. For when the dark sides of the rings are turned toward them, they will, in all probability, be invisible in their sky, as the dark side of the moon or of Venus is to us, and, therefore, they may be at a loss, in some instances, to discover the causes of such varieties of light and shade. For, although we are placed in a convenient position to perceive that they are in reality *complete rings* which environ the body of Saturn, yet it will not be so easy for its inhabitants to discover this fact; as only a portion of the rings will be visible in some places, and in the regions near the poles they will appear only like a bright streak in the horizon. They will naturally conclude that the shadows proceed from some body in their firmament; but they will require to make a great variety of observations, to

compare them together, and to investigate the doctrine of parallaxes, before they come to the conclusion that the phenomena alluded to are caused by mighty rings which encompass their habitation.

As the diameter of Saturn is ten times the diameter of the earth, it will be comparatively easy for its inhabitants to find the parallaxes, distances, and magnitudes of its different satellites, and likewise of Jupiter and Uranus, which are the only planets visible from Saturn. To those who dwell in its equatorial regions, the motion of the rings around their axis will furnish an accurate measure of time, as well as the diurnal rotation of the planet; and to all places on its surface the periodical revolutions of its different satellites will afford various measures, divisions, and subdivisions of the lapse of duration. The sun will appear from this planet of a size about five times the diameter which Jupiter presents to our view, or about 1-9th or 1-10th part of the diameter of the sun as seen from the earth; but, notwithstanding, there appears no deficiency of light on the surface of Saturn.

Let us, then, suppose two mighty arches in Saturn's nocturnal sky, appearing to the inhabitants of one region like broad semicircles of light extending completely across the heavens, to other regions like large segments of an arch, the highest point of which elevated only twenty or thirty degrees above the horizon, and to the places adjacent to the polar regions as a zone of light hovering in the horizon; let us suppose the distant stars twinkling through the dark space which separates the rings; the sun eclipsed at noon, in one place, by the upper edge of the rings, and in another place by the lower; the brightness of this luminary waxing dimmer and dimmer, and in a few hours hidden by an invisible object, not to appear again until after a lapse of fourteen years; and the inhabitants of this region of shadows occasionally traveling to those countries where the rings are enlightened and the sun is constantly shining; let us suppose one moon, nine times as large in apparent size as ours, suspended in the canopy of heaven; another, three times as large as ours, in another quarter of the sky; a third twice as large; a fourth about the apparent size of our moon; and a fifth, sixth, and seventh of different apparent magnitudes; some of them appearing with a crescent, some with a gibbous phase, and others with a full enlightened hemisphere; some rising, some setting; one entering into an eclipse, and another emerging from it; let us suppose such scenes as these, and we may acquire a general idea of the phenomena presented in the heavens of Saturn.

*Scenery of the Heavens in Uranus.*—The orbit of this planet, so far as we know, forms the extreme boundary of the planetary system. Being so far removed from the center of the system, almost all the other planets and their satellites will be invisible to a spectator placed on this orb. The only planet which will be distinctly visible is Saturn, which will be seen occasionally as a morning and an evening star, and will appear nearly of the same size as to us; but as it will always be seen in the immediate neighborhood of the sun, it will only be visible at certain distant periods, or intervals of fifteen years, and will appear about as near to the sun as Mercury does when viewed from the earth. Its rings and satellites might occasionally be perceived with such instruments as our best telescopes when it is near the points of its greatest elongation. It is not probable that Jupiter will be visible from this planet on account of its proximity to the sun. If ever it be visible, it will only be for a short time, after periods of six or eight years have elapsed. From Uranus it is

likely that the motions of some of the comets will be seen to advantage, and for a considerable length of time, as the motions of these bodies must be comparatively slow in those distant regions.— It is not improbable that, in their course from the sun, the motions of some of these bodies may be followed to the extreme point of their trajectories, and their courses traced in their return toward the central luminary; and that they may be visible in the firmament of this planet for months, and even for years together. It is likewise probable that, from Uranus, the parallax of the nearest fixed stars, and, consequently, their *distance*, may be ascertained. For the diameter of its orbit, which is 3,600,000,000 of miles, will form a pretty extensive *base line* for this purpose, and will produce a parallax nineteen times greater than that of the diameter of the earth's annual orbit, which is only 190 millions of miles. But the determination of such a parallax would require a series of observations made at intervals of forty-two years, namely, at two opposite points of the orbit of Uranus, in moving between which it occupies a space of nearly forty-two years.

The most splendid and interesting scenery in the firmament of this planet will be produced by the phases, eclipses, revolutions, and various aspects of its moons. Six of these bodies have been discovered revolving around it, and it is not improbable that several more (perhaps three or four) may be connected with this distant orb, the smallness of which, and their nearness to the planet, may forever prevent them from being detected by our most powerful instruments. Let us suppose, then, one satellite presenting a surface in the sky eight or ten times larger than our moon; a second five or six times larger; a third three times larger; a fourth twice as large; a fifth about the same size as the moon; a sixth somewhat smaller; and, perhaps, three or four others of different apparent dimensions: let us suppose two or three of these, of different phases, moving along the concave of the sky, at one period four or five of them dispersed through the heavens; one rising above the horizon, one setting, one on the meridian, one toward the north, and another toward the south; at another period five or six of them displaying their luster in the form of a half moon or a crescent in one quarter of the heavens, and at another time the whole of these moons shining, with full enlightened hemispheres, in one glorious assemblage, and we shall have a faint idea of the beauty, variety, and sublimity of the firmament of Uranus. What is deficient in respect of the invisibility of the other planets is amply compensated by its assemblage of satellites, which illuminate and diversify its nocturnal sky. Although this planet is more than seventeen hundred millions of miles nearer some of the fixed stars than we are, yet those luminaries will not appear sensibly larger, as seen from Uranus, than they do from our globe. For even this immense interval would not subtend an angle of nineteen seconds, or the 1-190th part of a degree, as seen from the nearest star; and, of course, all the constellations will present the same figures and relative aspects as they do to us, with this difference only, that those stars which are near our equator or tropics may be near the poles or polar circles of Uranus. This depends entirely upon the position of its axis of rotation, which is to us unknown. The sun will appear so small from this planet, that its apparent diameter will not exceed  $2\frac{1}{2}$  times the apparent diameter of Jupiter; but its light is not so weak as we might be apt to imagine from this circumstance, as is evident from the brightness it exhibits when

viewed with a telescope in the night-time, and likewise from the well-known phenomenon that when the sun is eclipsed to us, so as to have only the *one-fortieth* part of its disc left uncovered by the moon, the diminution of light is not very sensible; and it has been frequently noticed that, at the end of the darkness in total eclipses, when the sun's western limb begins to be visible, and seems no bigger than a thread of fine silver wire, the increase of light is so considerable, and so quickly illuminates all surrounding objects, as to strike the spectators with surprise. But whatever deficiency of light there may be on this planet, we may rest assured, from a consideration of the *wisdom* and benevolence of the Creator, that this deficiency is amply compensated, either by the objects on which it falls being endowed with a strong reflective power, or by the organs of vision being adapted to the light received, or by some other contrivances with which we are unacquainted.

#### SCENERY OF THE HEAVENS AS SEEN FROM THE SATELLITES.

*Celestial Scenery of the Moon.*—Although the moon is the nearest body to the earth, and its constant attendant, yet its celestial phenomena will, in a variety of respects, be very different from ours. The earth will appear to be the most splendid orb in its nocturnal sky, and its various phases and relative positions will form a subject of interesting inquiry and contemplation to its inhabitants. It will present the appearance of a globe in the sky *thirteen times larger* than the moon does to us, and will diffuse nearly a corresponding portion of light on the mountains and vales on the lunar surface. As the moon always presents nearly the same side to our view, so the earth will be visible to only one half of the lunar inhabitants. Those who live on the opposite side of the moon, which is never turned toward our globe, will never see the earth in the sky unless they undertake a journey to the opposite hemisphere for this purpose; and those who dwell near the central parts of that hemisphere which is turned from our globe will require to travel more than 1500 miles before they can behold the large globe of the earth suspended in the sky. To all those to whom the earth is visible, it will appear *fixed* and immovable in the same relative point of the sky, or, at least, will appear to have no circular motion round the heavens. To a spectator placed in the middle of the moon's visible hemisphere, the earth will appear directly in the zenith or over head, and will always seem to be fixed very nearly in that position. To a spectator placed in any part of the extremity of that hemisphere, or what seems to us to be the margin of the moon, the earth will appear always nearly in the horizon; and to spectators at intermediate positions the earth will appear at higher or lower elevations above the horizon, according to their distance from the extremities or the central parts of that hemisphere. But, although the earth appears fixed nearly in the same part of the sky, there is a slight variation produced by what is termed the *libration* of the moon (see p. 87), by which it appears to turn occasionally a small portion of its hemisphere toward the earth. In consequence of this libration the earth will appear now and then to shift its position a little by a kind of vibratory motion, so that those at the extremities of the hemisphere, who see the earth in their horizon, will sometimes see it dip a little below, and at other times rise a little above their horizon. This vibratory motion they will probably be disposed, at first view, to attribute to the earth,

which they will naturally consider as a body nearly at rest, but subject to a vibratory movement like that of a pendulum, whereas this apparent vibration proceeds from the moon itself.

The earth is continually shifting its *phases* as seen from the moon. When it is *new moon* to us it is *full moon* to the lunar inhabitants, as the hemisphere of the earth next the moon is then fully enlightened; so that, at the time when the sun is absent, they enjoy the effulgence of a full moon thirteen times larger than ours. When the moon is in the first quarter to us, the earth is in the third quarter to them; and, in every other case, the phases of the earth are exactly opposite to those which the moon presents to us (see p. 87). The earth passes through all the phases of the moon in the course of a month; but the *progress* of these phases will be more regularly and accurately perceived than that of the moon's phases are by us. When it is night in the moon, and the nights there are a fortnight long, the inhabitants see at first only a small part of the earth enlightened, like a slender crescent; then a larger and a larger portion, until at length it becomes entirely luminous. During the whole of these changes the earth is every moment visible, and apparently fixed in the same immovable position; and as there are no clouds in the lunar atmosphere, the view of the earth and of the variation of its phases will never be interrupted; whereas these changes in the moon are visible to us only from one night to another, and, by the interposition of clouds, the moon is frequently hidden from our view for seven or eight days together. By means of the light thus diffused by the earth upon the moon, it so happens that the side of the moon next the earth is never in darkness; for, when the sun is absent, the earth shines in the firmament with a greater or less degree of splendor; but when the sun is absent from the other hemisphere, the inhabitants have no light but what is derived from the stars and planets. It is probable, however, that the light of these luminaries is more brilliant as seen from the moon than from the earth; and as the lunar atmosphere is more pure and transparent than that of the earth, and as no clouds or dense vapors exist in it to intercept the rays of those distant orbs; and the stars and planets will constantly shine in the firmament of that hemisphere of the moon with undiminished luster.— Perhaps, too, there may be some arrangement for providing additional light to that hemisphere in the absence of the sun, either by the coruscations of some phosphoric substance, or by something analogous to our aurora borealis.

Whether the earth will throw as much light upon the moon, *in proportion to its size*, as the moon diffuses upon the earth, is somewhat doubtful. I am disposed to think that the greater part of the surface of the terraqueous globe will not reflect so much light, in proportion to its bulk, as the general surface of the moon; for, as the greater part of the earth is covered with water, and as water absorbs a considerable portion of the rays of light, the seas and ocean will present a more dark and somber aspect than any part of the lunar orb presents to us; but it is highly probable that the continents and islands will exhibit a luster nearly equal to that of the mountainous regions of the moon.

Although the earth will seem nearly fixed in one position, yet, its *rotation round its axis* will be *distinctly perceptible*, and will present a variety of different appearances. Europe, Asia, Africa, and America, will present themselves one after another in different shapes, nearly as they are represented

on our maps and globes; and the regions near our poles, which we have never yet had it in our power to explore, will be distinctly seen by the lunarians, who will be enabled to determine whether they chiefly consist of land or of water. The several continents, seas, islands, lakes, peninsulas, plains, and mountain-ranges, will appear like so many spots, of different forms and degrees of brightness, moving over its surface. When the Pacific Ocean, which occupies nearly half the globe, is presented to view, the great body of the earth will assume a dusky or somber aspect, except toward the north, the north-east, and north-west; and the islands connected with this ocean will exhibit the appearance of small lucid spots on a dark ground. But when the eastern continent turns round to view, the earth (especially its northern parts) will appear to shine with a greater degree of luster. These appearances will be diversified by the numerous strata of clouds which are continually carried by the winds over different regions, and will occasionally intercept their view of certain parts of the continents and seas, or render their appearance more obscure at one time than at another. It is likewise probable that the occasional storms in tropical climates, and the changes produced in different countries by summer and winter, will cause the earth to present a diversity of aspect to the inhabitants of the moon. The bands of ice which surround the poles will alternately exhibit a kind of lucid circle, while the verdant plains will appear of a different color and assume a milder aspect. By means of these different spots, the lunarians will be enabled to determine the exact period of the earth's rotation, as we determine that of the sun by the appearance and disappearance of the spots on its surface. And as the period of the earth's rotation never varies, it may serve as a clock or dial for the exact measure of time; and the lesser divisions of this period may be ascertained by the appearance on the margin or the central parts of the earth's hemisphere of certain seas, continents, or large islands, which will constantly appear on certain parts of the earth's disc at regular intervals of time. Through telescopes such as ours, the variegated aspect of the earth in its diurnal motion would present to us, were we placed on the moon, a novel and most interesting appearance.

The apparent diurnal motions of the sun, the planets, and the stars, will appear much slower, and somewhat different in several respects from what they do to us. When the sun rises in their eastern horizon, his progress through the heavens will be so slow that it will require more than seven of our days before he comes to the meridian, and the same time before he descends to their western horizon; for the days and nights of the moon are nearly fifteen days each, and they are nearly of an equal length on all parts of its surface, as its axis is nearly perpendicular to the ecliptic, and, consequently, the sun never removes to any great distance from the equator. During the day the earth will appear like a faint cloudy orb, always in the same position; and during night the stars and planets will be visible, *without interruption*, for fifteen days, and will be seen moving gradually during that time from the eastern to the western horizon. Though the earth will always be seen in the same point of the sky both by day and night, yet it will appear to be constantly shifting its position with respect to the planets and the stars, which will appear to be regularly moving from the east to the west of it, and some of them will occa-

sionally be hidden or suffer an *occultation* for three or four hours behind its body. The sun, planets, and fixed stars will appear exactly of the same apparent magnitudes as they do from the earth; but as the poles of the moon are directed to points of the heavens different from those to which the poles of the earth are directed, the pole-stars in the lunar firmament, and the stars which mark its equator and parallels, will all be different from ours; so that the stars, in their apparent diurnal revolutions, will appear to describe circles different from those which they describe in our sky. The *inferior* planets Mercury and Venus will generally be seen in the neighborhood of the sun, as they are from the earth; but they will be more distinctly perceived, and be visible for a much longer period of time after sunset than they are from our globe. This is owing, first, to the transparency of the lunar atmosphere, and the absence of dense vapors near the horizon, which, in our case, prevent any distinct observations of the celestial bodies when at a low altitude; and, secondly, to the slow apparent diurnal motion of these bodies. When Mercury is near its greatest elongation, it will remain above the horizon more than thirty hours after the sun has set, and, consequently, will be visible for a much longer time in succession than it is to us. When Venus is near its greatest elongation, it will be seen, without intermission, either as a morning or an evening star, for a space of time equal to more than three of our days. The *superior* planets, as with us, will be seen in different parts of the heavens, and occasionally in opposition to the sun; but they will appear to be continually shifting their positions with respect to the earth, and in the course of fifteen days will be seen in the very opposite quarter of the heavens, and in other fifteen days will be again in conjunction with the earth; and nearly the same appearances will be observed in reference to the other planets, but the periodic times of their conjunctions with the earth and oppositions to it will be somewhat different, owing to the difference of their velocities in their annual revolutions.

The *eclipses of the sun* which happen to the lunarians will be more striking, and total darkness will continue for a much longer time than with us. When a total eclipse of the *moon* happens to us, there will be a total eclipse of the *sun* to the lunarians. At that time the dark side of the earth is completely turned toward the moon, and the sun will appear to pass gradually behind the earth until it entirely disappears. The time of the continuance of *total darkness* in central eclipses will be nearly two hours; and, of course, a total eclipse of the sun will be a far more striking and impressive phenomenon to the inhabitants of the moon than to us. A complete darkness will ensue immediately after the body of the sun is hidden, and the stars and planets will be as clearly seen as at midnight. When a *partial* eclipse of the moon happens to us, all that portion of the moon's surface over which the shadow of the earth passes will suffer a *total* eclipse of the sun during the period of its continuance. On other parts of the moon's surface there will be a *partial* eclipse of the sun, and to those who are beyond the range of the earth's shadow no eclipse will appear. When an eclipse of the *sun* happens to us, the lunarians will behold a dark spot, with a penumbra or fainter shades around it, moving across the disc of the earth, which then appears a full enlightened hemisphere, excepting the obscurity caused by the progress of the shadow. The inhabitants on the other hemisphere of the

moon can never experience a solar eclipse, as the earth can never interpose between the sun and any part of that hemisphere, so that they will only know of such phenomena by report, unless they undertake a journey for the purpose of observing them.

The study of astronomy in the moon will, on the whole, be more difficult and complex than to us on the earth. The phenomena exhibited by the earth will be the most difficult to explain. The lunarians, at first view, will be apt to imagine that the earth is a quiescent body in their firmament, because it appears in the same point of the sky, and that the other heavenly orbs revolve around it. It will require numerous observations of the apparent motions of the sun, the earth, the planets, and the stars, and numerous trains of reasoning respecting the phenomena they exhibit, before they are convinced that the globe on which they dwell really moves round the earth, and that both of them move, in a certain period, around the sun. If they are endowed with no higher powers than man, or if they are as foolish and contumacious as the great bulk of mankind, it will be more difficult to convince them of the true system of the world than it has been for our astronomers to convince a certain portion of our community that the earth turns round its axis, and performs a revolution round the sun. They will naturally think, as we did formerly, that their habitation is in a quiescent state in the center of the universe, and that all the other bodies in the heavens, except the earth, revolve around it; and the singular phenomena which our globe exhibits in their sky, with its diversified aspect, its diurnal rotation, and occasional *vibrations*, will puzzle them not a little in attempting to find out a proper explanation. It will be somewhat difficult to them to ascertain the exact length of their year or the time of their revolution round the sun. There are only two ways by which we can conceive they will be enabled to determine this point:—1. By observing when either of the poles of the earth begins to be enlightened and the other pole to disappear, which is always at the time of our equinoxes. 2. By observing the course of the sun among the stars, and endeavoring to ascertain when he returns to the same relative position in reference to any of these orbs. The length of the lunar year is about the same as ours, but different as to the number of days, the lunarians having only 12 7-19 days in their year, every day and night being as long as 29½ of ours. On the other hand, the lunar astronomers will enjoy some advantages in making celestial observations which we do not possess. Those who live on the side next the earth will be enabled to determine the *longitude* of places on the lunar surface with as much ease as we find the *latitude* of places on our globe. For as the earth keeps constantly over one meridian of the moon (or very nearly so), the east and west distances of places from that meridian may be readily found, by taking the altitude of the earth above the horizon, or its distance from the zenith, on the same principle as we obtain the latitude of a place by taking the altitude of the pole-star, or the height of the equator above the horizon. The lunar astronomers will likewise possess advantages superior to ours in the purity of their atmosphere, and the greater degree of brilliancy with which the heavenly bodies will appear; and, in particular, they enjoy a singular advantage above a terrestrial astronomer in the *length of their nights*, which gives them an opportunity of contemplating the heavenly bodies, particularly Mercury and Venus, and tracing their

motions and aspects for a length of time without intermission.

Such are some of the peculiar phenomena of the heavens as beheld from the moon. However different these phenomena may appear from those which are beheld in our terrestrial firmament, they are all owing to the following circumstances: that the moon moves round the earth as the more immediate center of its motion; that it turns always the same side to the earth, and, consequently, it moves round its axis in the same time in which it moves round the earth. These slight differences in the motions and relative positions of the earth and moon are the principal causes of all the peculiar aspects of the lunar firmament which we have now described. And this consideration shows us how the Creator may, by the slightest changes in the positions and arrangements of the celestial orbs, produce an indefinite variety of scenery throughout the universe, so that no world or system of worlds shall present the same scenery and phenomena as another. And so far as our knowledge and observation extends, this appears to be one of the grand principles of the Divine arrangements throughout the system of Creation, which will be still more apparent from the sketches I am now about to give of the phenomena presented from the surfaces of the satellites connected with the other planets.

*The Scenery of the Heavens from the Satellites of Jupiter.*—The scenery of the firmament as beheld from the satellites of this planet will bear a certain analogy to what we have now described in relation to the moon, but it will be much more diversified and resplendent. The most striking and glorious object in the firmament of the *first satellite* is the planet itself. The distance of this satellite from the center of Jupiter being only about three diameters of that body, it will appear in the heavens like an immense globe, above thirteen hundred times larger than the apparent size of our moon, and will occupy a considerable portion of the celestial hemisphere. To those who live in the middle of the hemisphere of this satellite, opposite to Jupiter, this vast globe will appear in the zenith, filling a large portion of the sky directly above them, equal to 19 degrees of a great circle, so that nine or ten of such bodies would reach from one side of the heavens to another. To those in other situations it will appear at different elevations above the horizon, according to their distances from the central parts of that hemisphere. This huge globe, in the course of twenty-one hours, will exhibit a crescent, a half moon, a gibbous phase, and a full enlightened hemisphere, so that its appearance will be perpetually changing. When it shines with a full face, it will exhibit a most glorious appearance; it will reflect an immense quantity of light upon the satellite, and all the varieties on its surface will be beautifully perceived. In the day-time it will present a cloudy appearance, continually changing its form, and when its dark side is turned to the satellite it will probably become invisible; but it will never be altogether invisible beyond two or three hours at a time, until its enlightened crescent again begins to appear. We find by the telescope that the surface of Jupiter is diversified with a variety of belts, which frequently change their appearance, and sometimes by bright and dark spots. Now all the varieties on its surface, and the changes which may take place in its atmosphere, will be pretty distinctly seen from the surface of this satellite; and as Jupiter turns round its axis in the space of less than ten hours, every hour will present a new scene upon its sur-

face. This expansive and variegated surface of Jupiter, its diurnal rotation, and its rapid change of phases, will therefore form a most wonderful and interesting spectacle to the inhabitants of this satellite.

The three other satellites will likewise increase the variety and the luster of its firmament. The second satellite, in its course round Jupiter, will frequently come within 160,000 miles of the first, which is its nearest approach to it; at which time the satellite will appear with a face nearly three times as large as our moon. At other times it will be 680,000 miles distant, and will appear more than sixteen times smaller than in the former position. At the time when Jupiter presents its dark hemisphere to the first satellite, if the second satellite be then at its nearest distance, or in opposition to the sun, it will shine with a full enlightened hemisphere upon the first satellite. At other times it will assume a half moon, a crescent, or a gibbous phase; and these phases will not only be rapidly changing, but the apparent magnitude of the satellite will likewise be rapidly increasing or diminishing. While at one period it shines with a large and full enlightened face, in the course of two or three of our days it will appear as a slender crescent, and more than twelve or sixteen times less in apparent diameter than before. The third and fourth satellites will exhibit phenomena somewhat similar; but as their distance is greater than that of the second, their apparent magnitudes will be smaller, and the changes of their phases will be less frequent, in proportion to the slowness of their motions and the length of the periods of their revolutions. The eclipses of the sun, which so frequently happen to the first satellite from the interposition of the body of Jupiter, will form very interesting and impressive phenomena. Every forty-two hours this satellite suffers a solar eclipse for the space of more than two hours; and it is highly probable that it is chiefly at such times that the starry firmament appears in all its splendor, and affords its inhabitants an opportunity of tracing the motions and contemplating the phenomena of the distant bodies of the universe; for at other times the blaze of reflected light from the body of Jupiter and from the other satellites will, in all probability, prevent the greater part of the fixed stars from being distinctly perceived; so that these eclipses, instead of being an evil or a cause of annoyance to the inhabitants, will increase their enjoyment, will add to the variety of their celestial scenery, and open to them prospects of the grandeur of the starry firmament and the distant regions of creation.

What has been now stated in reference to the first satellite may also be applied in general to the other three satellites, with this difference, that Jupiter will appear of a different apparent magnitude from each satellite; and the motions, magnitudes, and aspects of the other satellites will likewise be somewhat different. In each satellite the great globe of Jupiter, suspended motionless in the sky, will be the most conspicuous object in the heavens. To the *second* satellite this globe will appear about 470 times larger than our moon; to the *third* 180 times; and to the *fourth* about 80 times the apparent size of the full moon. But each satellite will have certain other phenomena peculiar to itself, which it would be too tedious to describe. To all of them the occultations of the other satellites by the body of Jupiter; their eclipses by falling into its shadow; the varieties on its surface, caused by its diurnal rotation; the shadows of the satellites passing like dark spots

across its disc; the transits of the satellites themselves, like full moons crossing the orb of Jupiter; the diversified phenomena of eclipses, some of them happening when the satellite is like a crescent or half moon, and some of them when it appears as a full enlightened hemisphere, and various other circumstances, will afford an indefinite variety of celestial phenomena; and scarcely a single day will pass in which some of these phenomena are not observed. The length of the day is different in each satellite. In the first satellite, the length of the day and night is 42 hours 27 minutes; in the second, 3 days, 13 hours; in the third, 7 days, 3½ hours; and in the fourth, 16 days, 16½ hours. The starry heavens will therefore appear to make a revolution round each satellite in these respective times. The other satellites will also appear to make a diurnal revolution, but in periods of time somewhat different. The variety of motions, and other phenomena to which we have now alluded, and particularly the rotation of Jupiter and the variation of its phases, will afford various accurate measures of time to all the satellites. The following figure contains a rude sketch of a portion of the firmament as it will appear from one of the satellites of Jupiter.

Fig. 111.

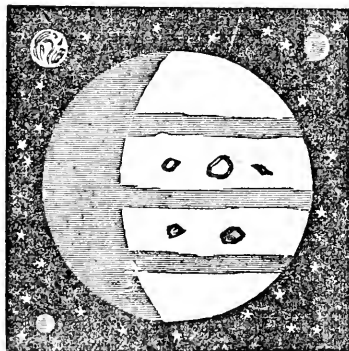

In this figure, suppose the larger circle at the top to represent one of the satellites as seen in the firmament of the fourth satellite, and suppose it appears with a surface twice the size of our moon; Jupiter would require to be double the size here represented, and more than fifteen times larger to represent its comparative size as viewed from the first satellite. The larger circle represents Jupiter when exhibiting a gibbous phase to the satellite; the three other figures are the other satellites under different phases.

*Celestial Scenery of the Satellites of Saturn.*—What has been stated above in relation to Jupiter's satellites will apply, in part, to those of Saturn. But the satellites of this planet have like-wise celestial scenery peculiar to themselves, and the scenes presented to one satellite are, in some respects, different from those presented to all the rest. One of the most singular phenomena in their firmament is the diversified appearance of the body of Saturn, and that of its rings, which will be beheld in their sky under a great variety of aspects. To describe all the variety of phenomena peculiar to each satellite connected with Saturn would almost require a separate treatise, and therefore I shall state only two or three prominent facts in relation to the first and seventh, or the innermost and outermost satellites. The first satellite, being only 80,900 miles distant from the surface of Saturn and only 18,000 miles from

the outer edge of the rings, the globe of Saturn and its stupendous rings must present a very august and striking appearance in its nocturnal firmament. The hemisphere of Saturn contains an area more than 1300 times larger than that of our moon; consequently, if the first satellite were placed at the same distance from Saturn as our moon, the surface of that planet would appear, from the satellite, 1300 times larger than the moon does to us. But the satellite is only 120,000 miles from the center of Saturn, or half the distance of the moon from the center of the earth; therefore Saturn will appear four times larger, or 5200 times greater, as seen from this satellite, than the moon when viewed from the earth. The moon occupies only the 1-30,000th part of our celestial hemisphere, but the globe of Saturn will fill one-seventeenth part of the visible firmament of its first satellite; and if we take the extent of the rings into account, they will occupy a space two or three times greater; so that the planet and its rings will present a most grand and magnificent object in the canopy of heaven, of which we can form only a very faint conception. It is not likely that more than one-half of the globe of Saturn will be visible from this satellite on account of the interposition of the rings; and as it moves in an orbit which is nearly parallel with the plane of the rings, the surfaces of these rings will be seen in a very oblique direction; but still they will exhibit a very resplendent appearance. When the edge of the exterior ring is opposite to the satellite, and enlightened by the sun, it will present a large arch of light in the heavens on each side of the planet, above which will appear half the hemisphere of Saturn. If the satellite turn round its axis in the same time in which it revolves round the planet, as is probable, Saturn and its rings will appear stationary in the heavens, and the planet will present to the inhabitants of the satellite a variety of phases, such as a half moon and a crescent, beside the variety of objects which will appear on the surface of Saturn during its rotation on its axis. The rings will likewise appear to vary their aspect during every revolution, beside the variety of objects they will present during their rotation. At one time they will exhibit large and broad luminous arches; at another time they will appear as narrow streaks of light; and at another they will appear like dark belts across the disc of Saturn. And as this satellite moves round the planet in the course of twenty-two and a half hours, these appearances will be changing almost every hour. The appearances of the six other satellites, continually varying their phases, their apparent magnitudes, and their relative aspects; their positions in respect to the body of Saturn and its rings; their occultations by the interposition both of the rings and the planet, and the eclipses to which they are frequently subjected, will produce a diversity of phenomena and a grandeur unexampled in the case of any other moving bodies in our system. The second satellite, when in opposition, or at its nearest position to the first, will be only thirty thousand miles distant; and although its real size is not greater than our moon, it will present a surface sixty-four times larger than the full moon does in our sky. It will appear in all the phases of the moon in the course of less than thirty-six hours, and will be continually changing its apparent magnitude, on account of its removing farther from or nearer to the first satellite. The third satellite\* will appear

\* Here the satellites are distinguished according to the order of their distances from Saturn.

nearly half as large, as it is only seventy thousand miles distant at its nearest approach; and will present nearly the same varieties as the other.—All the other satellites will appear smaller in proportion to their distance from the orbit of the first; but they will all appear much larger than our moon, except the seventh, or outermost satellite, which will appear considerably smaller. Perhaps the sixth satellite from Saturn will not appear larger than our moon.

The seventh or outermost satellite, which is reckoned among the largest, will have a scenery in its sky somewhat different from that of the first. As its orbit is materially inclined to the rings, its inhabitants will have a more ample prospect of these rings and of the body of Saturn than several of the other satellites, although these objects are beheld at a greater distance, and, consequently, will not fill so large a portion of its sky. Their appearance, however, will not be destitute of splendor; for this satellite is 430 times nearer Saturn than we are, and the body of this planet will appear sixteen times larger than the moon to us, and its rings will occupy a space proportionably more expansive. The phases of Saturn and its rings, and the various changes of aspect which they assume, will be more distinctly perceptible, though on a smaller scale, than from some of the interior satellites; for the whole body of the planet, as well as the rings, will in most cases appear full in view. The other six satellites will be seen in all the different phases and aspects above described, and they will never appear to recede to any great distance from the body of Saturn; but will appear first on one side and then on another, and sometimes either above or below the planet, as Mercury and Venus appear to us in respect to the sun, and, consequently, that portion of the heavens in which Saturn appears will present a most splendid appearance. In this respect the relative positions of the satellites, as seen from the outermost, will be different from their aspects and positions as viewed from the innermost satellite, where they will sometimes appear in regions of the sky directly opposite to Saturn. All the other satellites of this planet will have phenomena peculiar to themselves in their respective firmaments, and in all of them these phenomena will be exhibited on a scale of grandeur and magnificence. But to enter into details in reference to each satellite might prove tedious to the general reader.

Let us, then, conceive a firmament in which is suspended a globe five thousand times larger than the apparent size of our moon; let us conceive luminous arches, still more expansive, surrounding this globe; let us conceive six moons of different apparent magnitudes, some of them sixty times larger in apparent size than ours; let us conceive, further, all these magnificent bodies sometimes appearing in one part of the heavens and sometimes in another, changing their phases and apparent magnitudes and distances from each other every hour; appearing sometimes like a large crescent, sometimes like a small, sometimes shining with a full enlightened face, and sometimes suffering a total eclipse; sometimes hidden behind the large body of the planet, and sometimes crossing its disc with a rapid motion, like a circular shadow; let us suppose these and many other diversified phenomena presenting themselves with unceasing variety in the canopy of heaven, and we shall have some faint idea of the grandeur of the firmament as seen from some of the satellites of Saturn.

No delineations, except on a very large scale, could convey any tolerable idea of the objects

now described. Fig. 112 exhibits a rude idea of the firmament as viewed from the first or second satellite of Saturn; but the body of Saturn and

Fig. 112.

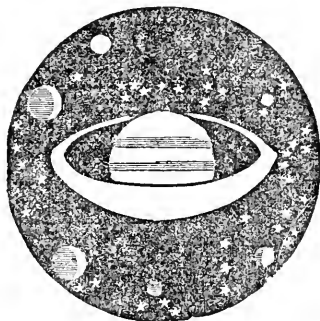

the ring should be eight or ten times larger in proportion to the size of the moons or satellites here represented. As the orbits of the inner satellites are nearly on the same plane as the rings, they will appear, in an oblique position, and it is questionable whether the division between the rings will be distinctly visible. The opposite part of the ring, or that which is most distant from the satellite, will appear smaller than the side which is nearest it; and only one-half of the body of Saturn will be seen, the other half being hidden, either in whole or in part, by the ring.

Fig. 113 represents the firmament of the seventh or outermost satellite. As its orbit is considerably inclined to the plane of the ring, the

Fig. 113.

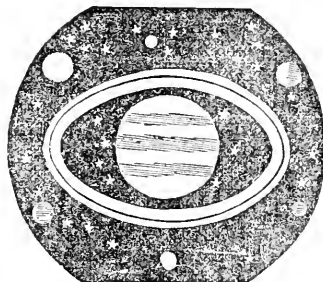

whole body of the planet will frequently be seen within the rings, which will appear as ovals around it. The six other satellites will appear in the vicinity of Saturn and its rings, none of them ever removing to any considerable distance from the edge of the rings, and some of them may occasionally be seen moving in the open space between the planet and the rings. In this figure Saturn and the rings should be considerably larger in proportion to the moons than they are here represented.

*Celestial Scenery as viewed from the Rings of Saturn.*—Supposing the rings to be inhabited, which there is as much reason to believe as that the planet itself is a habitable globe, it is probable that there is a greater diversity of celestial scenery and of sublime objects presented to view than any we have yet described. There will be at least six varieties of celestial scenery, according as the spectator is placed on different parts of the rings. One variety of scene will be exhibited from the exterior edge of the outer ring; a second

variety from the *interior* edge of the inner ring; a third variety from the interior edge of the *outer* ring; a fourth from the exterior edge of the *inner* ring; a fifth from the *sides* of the rings enlightened by the sun; and a sixth variety from the opposite sides, which are turned away from the sun, and enjoy, for a time, only the reflected light from the satellites. To describe all these varieties in a minute detail would be tedious, and at the same time unsatisfactory, without the aid of diagrams and figures on a very enlarged scale, and therefore I shall chiefly confine myself to a general description of one of these celestial views.

Those who live on the sides of the rings will behold the one-half of the hemisphere of Saturn, which will fill, perhaps, the one-fifth or the one-sixth part of their celestial hemisphere, while the other portions of the planet will be hidden by the interposition of the rings. Those who are near the inner edge of the interior ring are only thirty thousand miles from the surface of Saturn, and consequently all the varieties upon its surface will be distinctly perceived. Those near the outer edge of the exterior ring are about sixty thousand miles distant from the planet, which will consequently appear to them four times less in size than to the former; but being only eighteen thousand miles from the first satellite at the time of its opposition to Saturn, that satellite will present an object more than three hundred and fifty times larger than our moon, which will rapidly assume different phases, and will be continually varying in its apparent magnitude; and at its greatest distance beyond the opposite side of the rings it will appear at least 170 times less than when in the nearest point of its orbit; and all the intermediate varieties of magnitude and aspect will be accomplished within less than two days. So that this satellite will be continually changing its apparent size, from an object two or three times the apparent bulk of our moon to one 350 times greater. The same may be affirmed in respect to the other six satellites, with this exception, that they will appear of a smaller magnitude, and the periodic times of their phases and the changes in apparent magnitude will be different.

Another object which will diversify the firmament of those who are on one of the sides of the rings is the opposite portions of the rings themselves.—These will appear proceeding from each side of the planet like large broad arches of light, each of them somewhat less than a quadrant, and will fill a very large portion of the sky, so that the inhabitants of the same world will behold a portion of their own habitation forming a conspicuous part of their celestial canopy; and, at first view, may imagine that it forms a celestial object with which they have no immediate connection. Were they to travel to the opposite part of the ring, they would see the habitation they had left suspended in the firmament, without being aware that the spot which they left forms a portion of the phenomenon they behold. As the rings revolve round the planet, and the planet revolves round its axis, the different parts of the surface of the planet will present a different aspect, and its variety of scenery will successively be presented to the view. The eclipses of the sun and of the satellites, by the interposition of the body of Saturn and of the opposite sides of the rings, will produce a variety of striking phenomena, which will be diversified almost every hour.

From the dark side of the rings, which are turned away from the sun for fifteen years, a great variety of interesting phenomena will likewise be presented; and, during this period, the aspect of

the firmament will in all probability be most vivid and striking. This portion of the rings will not be in absolute darkness during the absence of the sun, for some of the seven satellites will always be shining upon it; sometimes three, sometimes four, and sometimes all the seven, in one bright assemblage. It is probable, too, that the planet, like a large slender crescent, will occasionally diffuse a mild splendor; and, in the occasional absence of these, the fixed stars will display their radiance in the heavens, which will be the principal opportunity afforded for studying and contemplating these remote luminaries. Those who are on the outermost ring will behold the other ring, and the opposite parts of their own, like vast arches in the heavens; and although only 2800 miles intervene between the two rings, that space may be as impassable as is the space which intervenes between us and the moon.

If the two rings have a rotation round Saturn in different periods of time, as is most probable, it will add a considerable variety to the scenery exhibited by the different objects which will successively appear in the course of the rotation.

The numerous splendid objects displayed in the heavens, as seen from these rings, would afford a grand and diversified field for telescopic observations, surpassing in variety and sublimity whatever is displayed in any other region of the solar system;

Fig. 114.

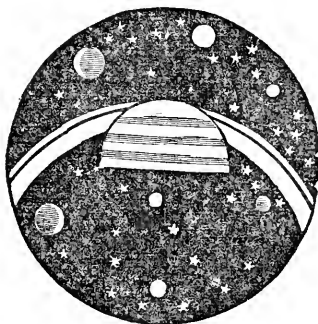

by which some of the objects might be contemplated as if they were placed within the distance of forty or fifty miles.

The preceding figure (114) represents a view of the firmament from one of the sides of the rings, in which is seen half of the hemisphere of Saturn, with a portion of the opposite sides of the rings projecting, as it were, from each side of the planet, the central part being hidden by the interposition of its body. From the inner edge of the interior ring the whole hemisphere of Saturn will be visible. The body of Saturn and the rings should be at least twenty times larger than here represented, so as to be proportionate to the apparent size of the satellites.

*Celestial Scenery from the Satellites of Uranus.*—After what we have stated respecting the satellites of Jupiter, it would be needless to enter into detail respecting the celestial views from the satellites of this planet, as they will bear a striking analogy to those of the moons of Jupiter; but the firmament of each satellite of Uranus will be more diversified than that of any of the satellites of Jupiter, as there are six satellites connected with this planet, and probably three or four more which lie beyond the reach of our telescopes.—From its first satellite the body of Uranus will



appear nearly three hundred times larger than the apparent size of the moon in our sky, and, consequently, will appear a very grand and magnificent object in its firmament, while the other five moons, in different phases and positions, will serve both to illuminate its surface, and to diversify the scenery of the heavens. To the second satellite Uranus will appear about one hundred and eighty times larger than the moon to us; and to the other satellites it will present a smaller surface in proportion to their distance. Each satellite will have its own peculiarity of celestial phenomena; but after what we have already stated in the preceding descriptions, it would be inexpedient to enter into details. I shall therefore conclude these descriptions with the following remarks:

1. In the preceding descriptions, the *apparent magnitudes* of Jupiter, Saturn, and Uranus, as seen from the satellites, and the apparent magnitudes of the satellites, as seen from each other, are only approximations to the truth, so as to convey a *general idea* of the scenes displayed in their respective firmaments; perfect accuracy being of no importance in such descriptions. 2. The variety of celestial phenomena in the firmaments of these bodies is much greater than we have described.— Were we to enter into minute details in relation to such phenomena, it would require a volume of considerable size to contain the descriptions; for in the system of Saturn itself there is more variety of phenomena than in all the other parts of the planetary system. 3. Machinery would be requisite in order to convey clear ideas of some of the views alluded to in the preceding descriptions, particularly in relation to the rings and satellites of Saturn, in which the proportional distances and magnitudes of the respective bodies would require to be accurately represented. An instrument of considerable size and complication of machinery would be requisite for exhibiting all the phenomena connected with Saturn; and one of the principal difficulties would be to produce a diurnal rotation of the rings round Saturn, while at the same time they had no immediate connection with it, and while their *thickness* was no greater in proportion to their breadth than what is found in nature, which is only about the one three hundredth part of the breadth of the two rings, including the empty space between them. 4. The diversity of celestial scenery to which we have alluded is an evidence of the *infinite variety*

which exists throughout the universe, and shows us by what apparently simple means this variety is produced. We are thus led to conclude, that among all the systems and worlds dispersed throughout boundless space, there is no one department of creation exactly resembling another. This is likewise exemplified in the boundless variety exhibited in our world, in the animal, vegetable, and mineral kingdoms. 5. The alternations of light and darkness, and the frequent eclipses of the celestial luminaries which happen among the bodies connected with Jupiter, Saturn, and Uranus, so far from being inconveniences and evils, may be considered as blessings and enjoyments; for it is only or chiefly when their inhabitants are deprived of the direct light of the sun, or its reflection from the satellites, that the starry heavens will appear in all their glory; and as the interval in which they are thus deprived of light is short, and as it adds to the variety of the celestial scene, it must be productive of pleasure and enjoyment. 6. The same planets will be seen in the firmaments of the satellites as in those of their primaries; but they will be seldom visible on account of the large portion of reflected light which will be diffused throughout their sky, except in those cases when their nocturnal luminaries suffer an occultation or a total eclipse. The bodies more immediately connected with their own system will form the chief objects of their attention and contemplation, and will appear more interesting and magnificent than any phenomena connected with more distant worlds. 7. On all the satellites, and particularly on the rings of Saturn, it will be more difficult to ascertain the true system of the universe than in any other point of the solar system. I have already alluded to the difficulty of determining the true system of the world as observed from the moon: but it will be still more difficult in the case of observers placed on the rings or satellites of Saturn. The numerous bodies which are seen every hour shifting their aspects and positions, the apparent complication of motions which they will exhibit, their phases, eclipses, and rapid diminution of apparent size, combined with the apparent diurnal revolution of the heavens and of all the bodies in their firmament, will require numerous and accurate observations, and powers of intellect superior to those of man, in order to determine with precision their place in the solar system and the true theory of the universe.

## CHAPTER IX.

### ON THE DOCTRINE OF A PLURALITY OF WORLDS, WITH AN ILLUSTRATION OF SOME OF THE ARGUMENTS BY WHICH IT MAY BE SUPPORTED.

In the preceding descriptions of the facts connected with the bodies which compose the planetary system, and of the celestial scenery displayed in their respective firmaments, I have assumed the position that they are all peopled with intellectual beings. This is a conclusion to which the mind is almost necessarily led, when once it admits the facts which have been ascertained by modern astronomers. It requires, however, a minute knowledge of the whole scenery and circumstances connected with the planetary system before this truth comes home to the understanding with full

conviction. As in the preceding pages I have stated, with some degree of minuteness, the prominent facts connected with all the bodies of the solar system (except comets), so far as they are yet known, the way is now prepared for bringing forward a few arguments founded on these facts, which will require less extensive illustrations than if I had attempted to discuss this topic without the previous descriptions. It may be proper, however, to state, that in this volume I propose to bring forward *only a few* of those arguments or considerations by which the position announced

above may be corroborated and supported, leaving the discussion of the remaining arguments to another volume, in which the other portions of the scenery of the heavens will be described. This is rendered almost indispensable on account of the size to which the present volume has already swelled.

### SECTION I.

The first argument I shall adduce in support of the doctrine of a plurality of worlds is, that *there are bodies in the planetary system of such MAGNITUDES as to afford ample scope for the abodes of myriads of inhabitants.*

This position has been amply illustrated in the preceding parts of this volume, particularly in chapter iii. From the statements contained in chap. vi, it appears that the whole planetary bodies, exclusive of the sun, comprehend an area of more than *seventy-eight thousand millions of square miles*, which is *three hundred and ninety-seven times* the area of our globe; so that the surfaces of all the planets and their satellites are equal, in point of space, to 397 worlds such as ours. But as the greater part of our globe is covered with water, and, consequently, is unfit for the permanent residence of rational beings, and as we have no reason to believe that the other planets have such a proportion of water on their surface, if we compare the habitable parts of the earth with the extent of surface on the planets, we shall find that they contain *one thousand five hundred and ninety-five times* the area of all that portion of our globe which can be inhabited by human beings. If we take into consideration the *solid contents* of these globes, we find that they are more than *two thousand four hundred and eighty times* the bulk of our globe; and the number of inhabitants they would contain, at the rate of England's population, is no less than 21,350,000,000,000, or nearly *twenty-two billions*, which is more than *twenty-seven thousand times* the present population of our globe. In other words, the extent of surface on all the planets, their rings and satellites, in respect of space for population, is equivalent to 27,930 such worlds as ours in its present state.

Now, can we for a moment imagine that the vast extent of surface on such magnificent globes is a scene of barrenness and desolation; where eternal silence and solitude have prevailed, and will for ever prevail; where no sound is heard throughout all their expansive regions; where nothing appears but interminable deserts, diversified with frightful precipices and gloomy caverns; where no vegetable or mineral beauties adorn the landscape; where no trace of rational intelligences is to be found throughout all their wastes and wilds; and where no thanksgivings, nor melody, nor grateful adorations ascend to the Ruler of the skies? To suppose that such is the state of these capacious globes would exhibit a most gloomy and distorted view of the character and attributes of the Creator. It would represent him as exerting his creating power to no purpose; and as acting in a different, and even in an *opposite character*, in different parts of his dominions; as displaying wisdom in one part of his creation, and an opposite attribute in another. For, so far as we are able to penetrate, it appears demonstrable that matter exists chiefly, if not *solely*, for the sake of sensitive and intellectual beings; either

to serve the purpose of gratifying the senses or of affording a medium of thought to the mental faculty, or of exhibiting to the mind a sensible display of the existence and perfections of the supreme Intelligence. And if it serve such purposes in this part of the creation which we occupy, reason says that it must serve similar purposes in other regions of the universe. How incongruous would it be to maintain that matter serves such purposes in our terrestrial sphere, and nowhere else throughout the range of the planetary system? In other words, that it is useful to sensitive existences within the compass of the *one four hundredth part* of that system, but serves no useful or rational purpose in the other three hundred and ninety-nine parts; for the area of the earth, as above stated, is only about the *one four hundredth part* of the area of all the other planets. Such a conclusion can never be admitted in consistency with those perfections which both natural and revealed religion attribute to the Deity. If matter was not created merely for itself, but for the enjoyment of a superior nature, then it necessarily follows, that *wherever matter exists, that nobler nature, whether sensitive or intellectual, for whose sake it was created, must likewise exist throughout some portions of its extent.* To replenish one comparatively little globe with sensitive and rational inhabitants, and to leave several hundreds empty, desolate, and useless, is the perfect reverse of art and contrivance, and altogether incompatible with the conceptions we ought to form of Him who is "the only wise God," and who is declared to have displayed himself, in all his operations, as "wonderful in counsel and excellent in working."

In accordance with this sentiment, we find the inspired writers, when speaking in the name of Jehovah, admitting the validity of such reasoning. "Thus saith Jehovah that created the heavens; God himself that formed the earth and made it: he hath established it; HE CREATED IT NOT IN VAIN; HE FORMED IT TO BE INHABITED. I am Jehovah, and there is none else."\* Here it is plainly and pointedly declared, that to create the earth without the design of its being inhabited would have been a piece of folly inconsistent with the perfections of Him whose intelligence and wisdom are displayed throughout all his works. "Have I left it empty and useless would have been "to create it in vain." It would neither have contributed to the enjoyment of intellectual beings, nor served as a manifestation of the intelligence, wisdom, and beneficence of its Creator. This passage likewise intimates that it is the ultimate design of Jehovah that this world shall, ere long, be fully peopled with inhabitants, and that its forests and desolate wastes shall, in future ages, be transformed into scenes of beauty and fertility, fitted for being the abodes of renovated moral agents at that period when "the knowledge of the Lord shall cover the earth;" and this extension of population and of cultivation is evidently going forward with rapid progress at the present time in different quarters of the globe. In connection with this declaration respecting the earth, it is also declared, that the same Almighty Being that arranged the earth for the purpose of replenishing it with inhabitants, likewise "*created the heavens;*" plainly intimating, that as both the fabrics were erected by the same all-wise and omnipotent intelligence, the same wisdom is displayed in both, and that the same grand and beneficent designs

\* Isaiah xlv. 13.

are accomplished in the globes which roll in the heavens as well as in the constitution of the earth in which we dwell. If the one was created for use, for the enjoyment of rational natures, and as a theater in which the Divine perfection might be displayed, so was the other. It is added, "I am Jehovah, and there is none else;" implying that there is a *unity* of principle, design, and operation, in all his plans and arrangements throughout the universe, however different in the means employed, and however varied the effects produced in different parts of his dominions.

Some, however, may be disposed to insinuate that the Deity may have designs in view, in the creation of matter, of which we are altogether ignorant, and that the planets and other bodies in the heavens may display the Divine glory in some way or another, although they be not peopled with inhabitants. It is readily admitted that we are ignorant of many of the purposes of the Deity, of the details of his operations in the distant regions of creation, and of many of the plans and movements of his moral government; and that, through an eternal lapse of ages, we shall always remain in ignorance of some of the works and ways of the Almighty. But there are certain general principles and views with which the Deity evidently intends that all his rational creatures should be acquainted. It was evidently intended that the visible creation should *adumbrate*, as it were, the character of Him who produced it; or that it should serve as a mirror, in which His existence and some of His perfections might clearly be perceived. But if the great globes of the universe were destitute of inhabitants, how could the Divine glory be discovered in their structure? How could a confused mass of rubbish and desolation, however vast and extensive, display the intelligence, the wisdom, and the benevolence of its Maker? It might indicate a power surpassing our comprehension, but it would display no other perfection which tends to excite the admiration, the love, and the adoration of rational beings. Yet we are informed in the Scriptures that celestial intelligences celebrate the perfections of Jehovah, "because he hath created all things," and because they perceive "His works" to be "GREAT AND MARVELOUS." They ascribe to Him "wisdom, and glory, and honor, and power, and thanksgiving," from the display of His character which they perceive in his works. But how could they ascribe to him such perfections, if the mightiest of his works were a scene of barrenness and desolation. Wisdom can be attributed only where there appears to be a proportionating of *means* to *ends*; and goodness can have no place where there are no sensitive or rational beings to enjoy the effects of it. It is, therefore, a mere evasion to assert that the Divine glory may be manifested in the celestial globes, although destitute of inhabitants. Every part of the character of God, by which he is rendered amiable and adorable in the eyes of his intelligent offspring, would be obscured and distorted were we for a moment to harbor such a sentiment. For wherein does the Divine glory consist? It chiefly consists in the display of infinite wisdom, rectitude, holiness, and unbounded beneficence; and where such attributes are not manifested there cannot be said to be a display of Divine glory. But such attributes could never be traced by man, or by any other order of intelligences, were the planetary bodies and the other orbs of heaven a scene of eternal silence, solitude, and waste; where no percipient being existed to taste the goodness or to adore the perfections of its Creator.

## SECTION II.

ARGUMENT II. *There is a GENERAL SIMILARITY among all the bodies of the Planetary System, which tends to prove that they are intended to subserve the same ultimate designs in the arrangements of the Creator.*

In the elucidation of this argument it will be requisite that a variety of facts, some of which have been noticed in the preceding pages, should be brought under review. We are not to imagine that the planets, considered as habitable worlds, are arranged exactly according to the model of our terrestrial habitation; for the Creator has introduced an infinite variety in every department of His works; and we know from observation that there are certain arrangements connected with those bodies which are very different from those which are found in connection with our globe. But in all worlds destined for the habitation of intellectual nature we should expect to find some general analogy or resemblance in their prominent features, and in those things which appear essential to the enjoyment of such beings. Were we to attend the dissection of any animal—a dog, for example—and perceive the heart, the stomach, the liver, the lungs, the veins, arteries, and other parts essential to life and enjoyment, we could scarcely doubt that the same organs, though perhaps somewhat modified, were likewise to be found in a cat, a bullock, or any other quadruped, and that they served the same purposes in all these animals. In like manner, when we find on our globe certain parts and arrangements essentially requisite to its being a habitable world, and when we likewise observe similar contrivances connected with other distant globes, we have every reason to conclude that they are intended to subserve similar designs. In accordance with this principle, I shall now proceed to detail a few contrivances and arrangements in the other planets, which evidently indicate that their grand and ultimate design is to afford enjoyment to sensitive and intellectual natures.

1. *All the planets, both primary and secondary, are of a spherical or spheroidal figure similar to that of the earth.* I have already shown (p. 103) that this figure is the most capacious and the best adapted to motion, both annual and diurnal, and that the greatest inconveniences would be produced were any world constructed of an angular figure. The only deviation from this figure is to be found in the rings of Saturn. But these rings are not angular bodies; for even the thin exterior edge of the rings is supposed, from some minute observations, to be curved; and, if so, it prevents the inconveniences which would arise from an angular construction. The flat sides of the rings, too, appear to have no angular elevations or protuberances more than what may be supposed from a gently-waving surface such as that of our globe; and although they are not globular bodies, they are *circular*, with thin edges, and are thus calculated for rapid motion along with the planet; and the flat sides, having no angular projections, appear perfectly adapted for being places of habitation, without any of those inconveniences or catastrophes which might ensue had they approximated to a cubical, prismatic, or pentagonal form. The rings, in short, approximate nearer to the globular figure and its conveniences than any other construction could have done, and show us that, although the Creator proceeds in his operations on some grand general principles, yet he is not limited or confined to one particular figure or

construction in arranging the celestial worlds. The planets, then, being all of a globular or circular form, appear completely adapted for being the abodes of living beings.

2. The planets are *solid bodies* similar to the earth. They are not merely a congeries of clouds and vapors formed into a globular shape, but possessed of weight, solidity, or gravity. This is evident from the dark and well-defined shadows which they throw on other bodies, and from the attractive influence they exert throughout the system. Their *figure* is a proof that they possess such qualities; for their roundness proceeds from an equal pressure of all their parts tending toward the same center. Nay, astronomers, by the aid of observation and mathematical calculations, can tell what are the relative gravities or weights of the different planets; what proportion, for instance, the gravitation of Jupiter or Saturn bears to that of our earth, and what influence their attractive power produces on their own satellites, on the motion of comets, and on the smaller and inferior planets. In consequence of this solidity and attractive power, all things connected with their surfaces are preserved in security and prevented from flying off to the distant regions of space; for it is this power, variously modified and directed, that preserves the material universe, and all the orders of beings connected with it, in compact order and harmony, without the influence of which all things in heaven and earth would soon be reduced to a universal chaos. In this respect, then, as well as in the former, the planets are fitted for the support of intellectual beings, furnished with material organs.

3. All the planets have an *annual revolution* round the sun. This revolution, in the case of the earth, combined with the inclination of its axis to the plane of its orbit, produces the variety of seasons; and although we are not to suppose that all the planets have seasons similar to ours, or that the heats of summer and the cold of winter are experienced in other worlds (see pp. 44, 45), yet there is a certain variety of scene produced by this revolution in all the planets, particularly in those which have their axes of rotation inclined more or less to the plane of their orbits. This variety of scene will be particularly experienced on Saturn and on the surface of its rings; for in the course of one-half of the annual revolution the sun will shine on certain parts of these bodies, and during the other half they will be deprived of his direct influence. The annual revolutions of the planets, therefore, appear expedient, in order to produce an agreeable interchange and variety of scenes, for the purpose of gratifying their inhabitants. The periods of these revolutions, too, are adjusted with the utmost exactness. The planets perform their circuits without deviating in the least from the paths prescribed, and finish their revolutions exactly in the appointed time, so as not to vary the space of a minute in the course of centuries. Now, were these bodies merely extensive regions of uncultivated deserts, or were they placed in the vault of heaven merely that a few terrestrial astronomers might peep at them occasionally through their glasses, it is not at all likely that so much care and accuracy would have been displayed in marking out their orbits and adjusting their motions and revolutions.

4. The planets perform a *diurnal rotation* round their axes. This has been ascertained in reference to Venus, Mars, Jupiter, and Saturn, and we may justly conclude, from analogy, that the same is the case in respect to all the other planets. Whenever spots have been discovered on the surface of

any planet, it has uniformly been found to have a diurnal rotation. But where no spots or prominences have been observed, it is obvious that no such motion, though it really exist, can be detected. No spots have been observed on the planet Mercury, on account of its smallness and its proximity to the sun; nor on the planet Uranus, on account of its very great distance from the earth; but there can be no doubt whatever that they have a diurnal motion as well as the other planets. By this motion every part of their surface is turned in succession toward the sun, and the alternate changes of day and night are produced. Were no such motion existing, one-half of these globes would be entirely uninhabitable, for the enlivening rays of the sun would never cheer its desolate regions, and the other half might be dazzled or parched with heat under the perpetual effulgence of the solar beams. Beside, the continuance of a perpetual day, and the illumination of the sky by an uninterrupted efflux of solar light, would prevent the distant regions of creation from being seen and contemplated, so that no body, except the sun himself, and the planet on which the spectator stood, would be known to exist in the universe. But it appears to have been the intention of the Creator not only to cheer the planets by the invigorating influence of the sun, but likewise to open to the view of their inhabitants a prospect into the regions of distant worlds, that they may behold a display of his wisdom and omnipotence, and of the magnificence of his empire; and this object has been completely effected in every part of the system by impressing upon the planets a motion of rotation, so that there is no body within the range of the solar influence that does not, at one period or another, enjoy this advantage.

The idea of night among the celestial bodies ought not to be associated with gloom, and darkness, and deprivation of comforts. In our world this is frequently the case. A cloudy atmosphere, combined with the fury of raging winds, hurricanes, and the appalling thunder-storm, frequently renders our nights a scene of gloom and terror especially to the benighted traveler and the mariner in the midst of the ocean. But such gloomy and terrific scenes would never have taken place had our globe and its inhabitants remained in that state of order and perfection in which they were originally created; and, therefore, we are to consider such physical evils as connected with the *moral state* of the present inhabitants of the earth. But even here, amid the gloom and darkness which frequently surround us, *night* not unfrequently opens to view a scene of incomparable splendor and magnificence; a scene which, were it confined to one quarter of the globe, millions of spectators would be eager to travel thousands of miles in order to behold it. In a clear and serene sky, night unfolds to us the firmament, bespangled with thousands of stars, twinkling from regions immensely distant, and the planets revolving in their different circuits, all apparently moving around us in silent grandeur. When the moon appears amid the host of stars, the scene is diversified and enlivened. Poets and philosophers in all ages have been charmed and captivated with the mild radiance of a moonlight scene, which partly unavails even the distant landscape, and throws a soft luster and solemnity both on earth and sky altogether different from their aspect under the meridian sun. But we have already shown (chapter viii) that the splendor of the heavens during night in some of the other planets is far more magnificent and diversified than what

is exhibited in our firmament. The nocturnal scenes in the heavens of Jupiter, Saturn, Uranus, and their rings and satellites, in point of sublimity and variety, exceed every conception we can now form of celestial grandeur and magnificence; and, therefore, it is highly probable, that in those regions the scenes of night will be far more interesting and sublime, and will afford objects of contemplation more attractive and gratifying than all the splendors of their noonday. In this rotation of the planetary orbs there is a striking display both of wisdom and goodness, in causing a means so apparently simple to be productive of so rich a variety of sublime and beneficent effects; and this circumstance of itself affords a strong presumptive evidence that every globe in the universe which has such a rotation is either a world peopled with inhabitants, or connected with a system of habitable worlds; for, without such a motion, the one-half, at least, of every globe would be unfit for the residence of organized intelligences. It is not improbable that most, if not all the globes of the universe have a diurnal rotation impressed upon them. We find that even the globe of the sun has a motion of this kind, which it performs in the course of twenty-five days; and the phenomena of variable stars have induced some astronomers to conclude that their alternate increase and diminution of luster is owing to a motion of rotation around their axes.

5. All the planets and their satellites are *opaque bodies*, which derive their luster from the sun. That Venus and Mercury are opaque globes, which have no light in themselves, is evident from their appearing sometimes with a gibbous phase, and at other times like a crescent or a half moon; and particularly from their having been seen moving across the disc of the sun like round black spots. Mars being a superior planet, can never appear like a crescent or a half moon; but at the time of its quadrature with the sun it assumes a gibbous phase, somewhat approaching to that of a half moon, which likewise prove that it is an opaque globe. Jupiter and Saturn must always appear round, on account of their great distance from the earth; but that Jupiter is opaque appears from the dark shadows of his satellites moving across his disc when they interpose between him and the sun; and that Saturn is likewise a dark body of itself appears from the shadow of the rings upon its disc. That the moon has an opaque body has been already shown (p. 88), and it is obvious to almost every observer; and that the satellites of Jupiter and Saturn are opaque appears from their eclipses, and the shadows they project on their respective planets. In this respect both the primary and the secondary planets are bodies analogous to the earth, which is likewise opaque, and derives its light either directly from the sun or by reflection from the moon, except the feeble rays which proceed from the stars. It forms, therefore, a presumptive argument that all these bodies have a similar destination; for we cannot conceive any other globe so well fitted for the habitation of rational beings as that which is illuminated by light proceeding from another body. An inherent splendor on the surface of any globe would dazzle the eyes with its brilliancy, and could never produce such a beautiful diversity of form, shade, and coloring as appears on the landscapes of the earth, by means of the reflections of the solar rays. And therefore, if the sun be inhabited, it can only be its dark central nucleus, and not the exterior surface of its luminous atmosphere.

6. The bodies belonging to the planetary sys-

tem are all connected together by one common principle or law, namely, the law of gravitation. They are all subject to the attractive influence of the great central luminary; they revolve around it in conformity to the general law, that the squares of their periodical times are proportional to the cubes of their distances; they describe equal areas in equal times; their orbits are elliptical; they are acted upon by centripetal and centrifugal forces; and they all produce an attractive influence on each other, in proportion to their distances and the quantity of matter they contain. Being thus assimilated and combined into one harmonious system, the presumption is, that, however different in point of distance, magnitude, and density, they are all intended to accomplish the same grand and beneficent design, namely, to serve as the abodes of living beings, and to promote the enjoyment of intellectual natures.

Since the planets, then, are all similar to one another in their spherical or spheroidal figures; in their being solid and opaque globes; in their annual and diurnal revolutions; and in being acted upon by the same laws of motion; and since these circumstances are all requisite to the comfort and enjoyment of living beings, it is a natural and reasonable conclusion that their ultimate destination is the same, and that they are all replenished with inhabitants. This earth on which we dwell is one of the bodies possessed of the qualities and arrangements to which we allude; and we know that its chief and ultimate design is to support a multitude of sensitive and intellectual beings, and to afford them both physical and mental enjoyment. Had not this been its principal destination, we are assured, on the authority of Divine revelation, that "*it would have been created in vain.*" We must therefore conclude that all the other globes in our system were destined to a similar end, unless we can suppose it to be consistent with the perfections of Deity that they were created for no purpose.

### SECTION III.

ARGUMENT III. *In the bodies which constitute the solar system, there are SPECIAL ARRANGEMENTS which indicate their ADAPTATION to the enjoyments of sensitive and intelligent beings; and which prove that this was the ultimate design of their creation.*

This argument is somewhat similar to the former; but it may be considered separately, in order to prevent an accumulation of too many particulars under one head.

1. The surfaces of the plains are diversified with hills and valleys, and a variety of mountain-scenery. This is particularly observable in the moon, whose surface is diversified with an immense variety of elevations and depressions, though in a form and arrangement very different from ours (see pp. 88-91). It cannot be ascertained by direct observation that there are mountains on the surfaces of Jupiter, Saturn, or Uranus, by reason of their great distances from the earth. But that they are rough or uneven globes appears from their reflecting the light to us from every part of their surfaces, and from the spots and differences of shade and color which are sometimes distinguishable on their discs. For if the surfaces of the planets were perfectly smooth and polished, they could not reflect the light in every direction; the reflected image of the sun would be too small to strike our eyes, and they would consequently be invisible. (See p. 88.)

Indications of mountains, however, have been seen on some of the other planets, particularly on Venus. Spots have been observed on this planet on different occasions, and the boundary between its dark and enlightened hemisphere has appeared jagged or uneven, a clear proof that its surface is diversified with mountains and vales. One of these mountains was calculated by Schroeeter to be nearly eleven, and another twenty-two miles in perpendicular elevation; and there can be but little doubt that such inequalities are to be found on the surfaces of all the planets and their satellites, although they are not distinctly visible to us on account of their distance.

The existence of *mountains* on the planets is therefore a proof, or, at least, a strong presumptive evidence, that they are habitable worlds; for a perfectly smooth globe could present no great variety of objects or picturesque scenery, such as we behold in our world, and would doubtless be attended with many inconveniences. The view from any point of such a globe would be dull and monotonous, like the expanse of the ocean, or like the deserts of Zahara or Arabia. It is the beautiful variety of hills and dales, mountains and plains, and their diversity of shadows and aspects, that render the landscapes of the earth interesting and delightful to the painter, the poet, the man of taste and the traveler. Who would ever desire to visit distant countries, or even distant worlds, if they consisted merely of level plains, without any variety, of several thousands of miles in extent? The mountains add both to the sublimity and the beauty of the surface of our globe; and from the summits of lofty ranges the most enchanting prospects are frequently enjoyed of the rivers and lakes, the hills and vales, which diversify the plains below. But beside the beauty and variety which the diversity of surface produces, mountains are of essential use in the economy of our globe. They afford many of the most delightful and salubrious places for the habitations of man; they arrest the progress of stormy winds; they serve for the nourishment of animals, and the production of an infinite variety of herbs and trees; they are the depositories of stones, metals, minerals, and fossils of every description, so necessary for the use of man; and they are the portions of the globe where fountains have their rise, and whence rivers are conveyed to enliven and fertilize the plains. For, if the earth were divested of its mountains, and every part of its surface a dead level, there could be no running streams or conveyance for the waters, and they would either stagnate in large masses or overflow immense tracts of land. Hence it has been arranged by the wisdom of Providence that mountains should exist over all our globe, and that every country should enjoy the numerous benefits which such an arrangement is fitted to produce.

As mountains, then, are part of the arrangements of other globes in the solar system, and as they are essentially requisite in such a world as ours, they may serve similar and even more important purposes in other worlds. In some of the planets they appear to be more elevated and of greater dimensions than on the earth. Although the moon is much less in size than our globe, yet some of its mountains are reckoned to be five miles in perpendicular light. Some of the mountains on Venus are estimated to be four times higher than even this elevation. We may easily conceive what an extensive and magnificent prospect would be presented from the top of such sublime elevations, and what a diversity of objects would be presented to the eye from one point of

view. Nor need we imagine there will be any great difficulty in ascending such lofty eminences; for the inhabitants of such worlds may be furnished with bodies different from those of the human race, and endowed with locomotive powers far superior to ours. If, therefore, the planets were found to be perfectly smooth globes, without any elevations or depressions, we should lose one argument in support of their being designed for the abodes of rational beings; but having the characteristic now stated, when taken into consideration with other arguments, it corroborates the idea of their being habitable worlds.

2. The planets, in all probability, are environed with *atmospheres*. It appears pretty certain that the moon is surrounded with such an appendage (see pp. 93, 94). The planet Mars is admitted by all astronomers to be environed with a pretty dense atmosphere, which is the cause of its ruddy appearance (see pp. 49, 50); and indications of an atmosphere have been observed on Venus and some of the other planets. To our world an atmosphere is a most essential appendage. Without its agency our globe would be unfit for being the residence of living beings constituted as they now are; and were it detached from the earth, all the orders of animated nature, and even the vegetable tribes would soon cease to exist. Atmospheres somewhat analogous to ours may likewise be necessary in other worlds. But we have no reason to conclude that they are exactly similar to ours. While our atmosphere consists of a compound of several gaseous substances, theirs may be formed of a pure homogeneous ethereal fluid, possessed of very different properties. While ours is impregnated with dense vapors, and interspersed with numerous strata of thick clouds, the atmosphere of some of the other planets may be free of every heterogeneous substance, and perfectly pure and transparent. Their reflective and refractive powers, and other qualities, may likewise be different from those of the atmosphere which surrounds the earth. Hence the folly of denying the existence of an atmosphere around the moon or any other planet, because a fixed star or any other orb is not rendered dim or distorted when it approaches its margin. For if its atmosphere be either of small dimensions, or perfectly pure and transparent, or of a different refractive power from ours, such a phenomenon cannot be expected. We have no more reason to expect that the atmospheres of other planets should be similar to ours, than that these bodies should be of the same size, have the same diversity of objects on their surface, or be accompanied with the same number of moons.

It is not likely that our atmosphere is precisely in the same state as at the first creation. Its invigorating powers had then an influence sufficient to prolong human existence to a period of a thousand years; but, since the change it underwent at the deluge, the period of human life has dwindled down to little more than "threescore years and ten." The present constitution of our atmosphere, therefore, ought not to be considered as a model by which to judge of the nature and properties of the atmospheres of other worlds. Their atmospheres may be so pure and transparent as to enable their inhabitants to penetrate much farther into space than we can do, and to present to them the heavenly bodies with more brilliancy and luster; and the properties with which they are endowed may be fitted to preserve their corporeal organs in undecaying vigor, and to raise their spirits to the highest pitch of ecstasy, similar to some of the effects produced on our frame by

inhaling that gaseous fluid called the *nitrous oxide*. There is only one planet whose atmosphere appears to partake of the impurity and density of that of the earth, and that is the planet Mars; and several other circumstances tend to show that it bears too near a resemblance to our globe. In this respect, then, it gives indication of being a habitable world; but several of the other planets may be abodes of greater happiness and splendor, although no traces of such an appendage can be distinguished by our telescopes. And this very circumstance, that their atmospheres are invisible, should lead us to conclude that they are purer and more transparent than ours, and that the moral and physical condition of their inhabitants is probably superior to what is enjoyed upon earth.

3. There is provision made for the *distribution of light, and heat, and color* among all the planets and their satellites. On every one of these bodies the sun diffuses a radiance, and, in order that no portion of their surfaces may be deprived of this influence, they appear all to have a motion round their axes. *Light* is an essential requisite to every world, and *color* is almost equally indispensable. Without color we should be unable to perceive the forms, proportions, and aspects of the objects which surround us; we could not distinguish one object from another; all the beauties, varieties, and sublimities of nature would be annihilated, and we should remain destitute of the noblest entertainments of vision. It is color which enlivens every scene of nature, which adds a charm to every landscape, and gives an air of beauty and magnificence to the spacious vault of heaven. Now color exists in the solar rays, without which, or some similar radiance, every object is either invisible or wears a uniform aspect. On whatever object these rays fall, color is produced; they have the same properties in every part of the system as on our globe, and, therefore, must produce colors of various hues on the objects connected with the remotest planets, according to the nature of the substances on which they fall. Light and color, then, being essential to every globe intended for the habitation of living beings, abundant provision has been made for diffusing their benign influence through every part of the planetary system. Heat is likewise an agent which appears necessary to every world, and it is, doubtless, distributed in due proportions throughout the system, according to the nature of the substances of which the planets are composed, and the constitution of their inhabitants. But light, and color, and heat are agencies which can only have an ultimate respect to sensitive and intellectual beings; and, therefore, where no such beings exist or are intended to exist, no such provision would be made by a wise and intelligent agent. Such care as appears to have been taken for the communication of the agencies of light, heat, and color, would never have been exercised for the sake of rocks and deserts, and scenes of sterility and desolation. The existence of *light*, with all the enchanting effects it produces, necessarily supposes the existence of *eyes*, in order to enjoy its beneficial influence; and, therefore, organized beings, endowed with *visual organs*, must exist in all those regions where contrivances have been adapted for its regular and universal diffusion; otherwise the universe might have remained a scene of eternal darkness.

4. The principal primary planets are *provided with secondary planets or moons*, to afford them light in the absence of the sun, as well as to accomplish other important purposes. The three largest planets of the system are accommodated

with no fewer than *seventeen* of those nocturnal luminaries, and probably with several more which lie beyond the reach of our telescopes. Our earth has one; and it is not improbable that both Mars and Venus are attended by at least one satellite. These attendants appear to increase in number in proportion to the distance of the primary planet from the sun. Jupiter has four such attendants; Saturn, seven; six have been discovered around Uranus; but the great difficulty of perceiving them, at the immense distance at which we are placed, leads to the almost certain conclusion that several more exist which have not yet been detected. While these satellites revolve round their respective planets, and diffuse a mild radiance on their surfaces in the absence of the sun, they also serve the same purposes to one another; and their primaries, at the same time, serve the purpose of large resplendent moons to every one of their satellites, beside presenting a diversified and magnificent scene in their nocturnal sky. No satellite has yet been discovered attending the planet Mercury, nor is it probable that any such body exists. But we have already shown (pp. 114, 115) that Venus and the earth serve the purposes of satellites to this planet, Venus sometimes appearing six times as large, and the earth two or three times as large as Venus does to us at the period of its greatest brilliancy; so that the nights of Mercury are cheered with a considerable degree of illumination. Here, then, we perceive an *evident design* in such arrangements, which can have no other ultimate object in view than the comfort and gratification of intelligent beings. For a retinue of moons, revolving around their primary planets at regular distances and in fixed periods of time, would serve no useful purpose in throwing a faint light on immense deserts, where no sensitive beings, furnished with visual organs, were placed to enjoy its benefits; nor, if this were the case, is it supposable that so much skill and accuracy would have been displayed in arranging their distances and their periodical revolutions, which is accomplished with all the accuracy and precision which are displayed in the other departments of the system of nature.

The *small density* of the larger and more remote planets, and the *diminution of the weight of bodies on their surfaces* on this account, and by their *rapid rotation* on their axes, appear to be instances of design which have a respect to sentient beings. The density of Jupiter is little more than that of water, and that of Saturn about the density of cork. Were these planets as dense as the planet Mercury, or had they even the density of the earth, organized beings like man would be unable to traverse their surfaces. If the density of Jupiter, for example, were as great as that of the earth, the weight of bodies on its surface would be eleven times greater than with us; so that a man weighing 160 pounds on the earth would be pressed down on the surface of Jupiter with a force equal to one thousand seven hundred and sixty pounds. But the gravity of bodies on the surface of this planet is only about twice as great as on the surface of the earth; and *this gravitating power is diminished by its rapid rotation on its axis*. For the centrifugal force which diminishes the weight of bodies is *sixty-six* times greater on Jupiter than on the earth, and will relieve the inhabitants of one-eighth part of their weight, which they would otherwise feel if there were no rotation; so that a body weighing 123 pounds if the planet stood still, would weigh only 112 pounds at its present rate of rotation, which will afford a sensible relief and diminution of

weight (see p. 59, Art. *Jupiter*). The same may be said, with some slight modifications, in relation to Saturn. There must, therefore, have been a *design*, or a wise and prospective contrivance in such arrangements, to suit the exigencies and to promote the comfort of organized intelligences; otherwise, had Jupiter and Saturn been as much denser than the earth as they are lighter, every body would have been riveted to their surfaces with a force which beings like man could never have overcome; and moving beings with such organical parts as those of men would have had to drag along with them a weight of eight or ten thousand pounds.

In the preceding statements I have endeavored to show that there is a *general similarity* among all the bodies of the planetary system, and that there are *special arrangements* which indicate their *adaptation* to the enjoyment of sensitive and intellectual beings. Let us now consider more particularly the force of the argument derived from such considerations :

That the Divine Being has an *end* in view in all his arrangements, and that this end is in complete correspondence with his infinite wisdom and goodness, and the other perfections of his nature, is a position which every rational Theist will readily admit. That some of the prominent designs or general ends which the Deity intended to accomplish may be traced in various departments of his works, is likewise a position which few or none will deny. That design may be inferred from its effects, is a principle which mankind generally recognize in their investigations of the operations both of nature and of art. That man would justly be accused of insanity who, after inspecting the machinery of a well-constructed clock, and perceiving that it answered the purpose of pointing out the divisions of time by hours, minutes, and seconds with the utmost accuracy, should *deny* that its various parts were formed and arranged for the very purpose which the machine so exactly fulfills; at least, that the pointing out of the hours and minutes was one of the main and leading objects which the artist had in view in its construction. It is a law of our nature which we cannot resist, that from the effect the design may be inferred; and that, wherever art or contrivance appears exactly adapted to accomplish a certain end, that end was intended to be accomplished. We cannot doubt for a moment of the final causes of a variety of objects and contrivances which present themselves to view in the world we inhabit. We cannot err in concluding, for example, that the ears, legs, and wings of animals were made for the purpose of hearing, walking, and flying. On the same principle we are led to conclude, that as animals are formed with mouths, teeth, and stomachs to masticate and digest their food, so vegetables and other organized bodies were formed for the purpose of affording that nourishment which the animal requires. No one will take upon him to deny that the eye was intended for the purpose of vision. The coats and humors of which it is composed, and the muscles which move it in every direction, in their size, shape, connection, and positions, are so admirably adapted to this end, and the transparency of the *cornea*, and the *humors*, the opacity of the *uvea*, and the semi-opacity and concavity of the *retina*, are so necessary to transmit and refract the rays of light in order to distinct vision, that it appears as evident it was designed for this pur-

pose, as that telescopes were constructed to discover the colors, shapes, and motions of distant objects. And as the eye was constructed of a number of nice and delicate parts for the purpose of vision, so light was formed for the purpose of acting upon it and producing the intended effect, without the agency of which vision could not be produced. The one is exactly adapted to the other; for no other substance but light can affect the eye so as to produce vision, and no other organ of sensation is susceptible of the impressions of light, so as to convey a perception of any visible object. In all such cases, the adaptation of one contrivance to another, and the intention of the Contriver, are quite apparent.

It is true, indeed, that we cannot pretend to explore *all the ends or designs* which God may have had in view in the formation of any one object or department of the universe. For an eternal and omniscient Being, whose wisdom is unsearchable, and whose eye penetrates through all the regions of immensity, may have subordinate designs to accomplish, which surpass the limited faculties of man, or even of angels, to comprehend. But to investigate and to perceive *some* of the main and leading ends which were designed in the arrangement of certain parts of the universe, is so far from being presumptuous and unattainable, that it would be blindness and folly in a rational creature not to discover them; particularly in such instances as those to which we have now alluded. For it appears to be the intention of the Deity, in displaying his works to intelligent minds, that these works shall exhibit a manifestation of his attributes, and particularly of his wisdom, goodness, and intelligence; and he has endowed them with faculties adequate to enable them to perceive some traces of his footsteps and of the plan of his operations. But while he permits us to perceive some of the grand lineaments of his designs, there may be numberless minute and subordinate ends which lie beyond the sphere of our investigations. Were a peasant brought into the observatory of an astronomer, and shown an instrument calculated to point out the sun's place in the ecliptic, its declination and right ascension, the day of the month, &c., and particularly the *hour* of the day, it would be presumptuous in such a person to pretend to ascertain *all* the intentions of the artist, or all the uses for which such a machine was constructed; but when he beheld the ordinary marks of a sun-dial, and the shadow of the gnomon accurately pointing to the hour, he could not fail at once to perceive that this was *one* principal end which the contriver had in view. In like manner, while we evidently perceive that one principal design of the creation of the sun was to enlighten the earth and other bodies which move around it, it also serves several subordinate purposes. It directs the course of winds, promotes evaporation and the growth of vegetables; it retains the planets in their orbits; it kindles combustible substances by means of convex glasses and concave mirrors; it enables us to measure time by means of dials; it directs the geographer to determine the elevation of the pole and the latitude of places; it guides the navigator in his course through the ocean, and even its eclipses serve many useful purposes, both in chronology and astronomy; and it may serve similar or very different purposes with which we are unacquainted, among the inhabitants of other worlds. All these purposes, and many more of which we are ignorant, may have entered into the designs of the almighty Creator, although, in the first instance, we might have been unable to discover



or appreciate them. As "the works of the Lord are great," so they must "be sought out," or diligently investigated, in order that we may clearly perceive the manifold designs of infinite wisdom.

Let us now apply these principles to the subject more immediately before us. We have seen that, in the distant bodies of our system, there are special contrivances and arrangements, all calculated to promote the enjoyment of myriads of intelligent agents. We have presented before us a most august and astonishing assemblage of means; and if the Contriver of the universe is possessed of wisdom, there must be an *end* proportionate to the utility and grandeur of the means provided. Arrangements nearly similar, but much inferior in point of extent and magnificence, have been made in relation to the globe on which we live. We know the final cause, or, at least, one of the principal designs for which it was created, namely, to support sensitive and intellectual beings, and to contribute to their enjoyment. If, then, the Creator acts on the same principle—in other words, if he displays the same intelligence—in other regions of the universe as he does in our world, we must admit that the planetary globes are furnished with rational inhabitants. There is one essential attribute which enters into all our conceptions of the Divine Being, namely, that he is possessed of infinite wisdom. This perfection of his nature is displayed in all the general arrangements he has made in this lower world, where we find one part nicely adapted to another, and everything so balanced and arranged as to promote the comfort of sentient beings. In consequence of His being possessed of this perfection, He must be considered, in all His operations throughout the immensity of space, as proportionating the means to the end, and selecting the best means possible for the accomplishment of any design; for in such contrivances and operations true wisdom consists.

But now let us suppose for a moment that the vast regions on the surfaces of the planets are only immense and frightful deserts, devoid of inhabitants; *wherein does the wisdom of the Creator appear on this supposition?* For what purpose serves the grand apparatus of rings and moons for adorning their sky and reflecting light on their hemispheres? Why are they made to perform annual and diurnal revolutions, and not fixed in the same points of infinite space? Why are the larger and remoter planets furnished with more moons than those which are nearer the source of light? Why are their firmaments diversified with so many splendid and magnificent objects? Why is their surface arranged into mountains and vales? Why has so much contrivance been displayed in devising means for the illumination of every portion of their surfaces, and diffusing over them a variety of colors? The answers to such questions would, then, be, to illuminate an immense number of dreary wastes, and to produce days and nights, and a variety of seasons, for the sole benefit of innumerable deserts, or, at most, of mountains of marble or rocks of diamonds; to afford them light enough to see to keep their orbits, lest they might miss their way in the pathless spaces through which they move! Is such an apparatus requisite for such a purpose? *Would this be an end worthy of INFINITE WISDOM?* Would it at all correspond with the dignity and grandeur of the means employed? Would it comport with the boundless intelligence of Him "who formed the earth by his wisdom, and stretched out the heavens by His understanding?" To maintain such a position would be to distort the Divine character, and to undermine all the conceptions we ought to form of the Deity,

as wise, amiable, and adorable, and as "great in counsel and mighty in operation." If we beheld an artist exerting his whole energies, and spending his whole life in constructing a large complex machine which produced merely a successive revolution of wheels and pinions, without any useful end whatever in view, however much we might extol the ingenuity displayed in some parts of the machine, we could not help viewing him as a fool or a maniac in bestowing so much labor and expense to no purpose. For it is the *end* or design intended which leads us to infer the wisdom of the artist in the means employed. And shall we consider the ALL-WISE AND ADORABLE CREATOR OF THE UNIVERSE as acting in a similar manner? The thought would be impious, blasphemous, and absurd. It is only when we recognize the Almighty as displaying infinite wisdom in all his arrangements throughout creation, and boundless beneficence in diffusing happiness among countless ranks of intelligent existence, that we perceive him to be worthy of our admiration and gratitude, and of our highest praises and adorations. We are, therefore, irresistibly led to the conclusion, that the planets are the abodes of intelligent beings, since every requisite arrangement has been made for their enjoyment. This is a conclusion which is not merely probable, but absolutely certain; for the opposite opinion would rob the Deity of the most distinguishing attribute of his nature, by virtually denying him the perfection of infinite wisdom and intelligence.

#### SECTION IV.

ARGUMENT IV. The scenery of the heavens as viewed from the surfaces of the larger planets and their satellites, forms a presumptive proof that both the planets and their moons are inhabited by intellectual beings.

In the preceding chapter I have described at some length the celestial phenomena of the planets, both primary and secondary. From these descriptions it appears that the most glorious and magnificent scenes are displayed in the firmament of the remoter planets, and particularly in those of their satellites. Even the firmament of the moon is more striking and sublime than ours. But in the firmaments of some of the satellites of Jupiter and Saturn there are celestial scenes peculiarly grand and splendid, surpassing everything which the imagination can well represent, and these scenes diversified almost every hour. What should we think of a globe appearing in our nocturnal sky 1300 times larger than the apparent size of the moon, and every hour assuming a different aspect? of five or six bodies twenty or thirty times larger than our moon appears, all in rapid motion, and continually changing their phases and their apparent magnitudes? What should we think of a globe filling the twentieth part of the sky, and surrounded with immense rings, in rapid motion, diffusing a radiance over the whole heavens? When Jupiter rises to his satellites, and especially when Saturn and his rings rise to his nearest moons, a whole quarter of the heavens will appear in one blaze of light. At other times, when the sun is eclipsed, or when the dark sides of these globes are turned to the spectator, the *starry* firmament will open a new scene of wonders, and planets and comets be occasionally beheld in their courses through the distant regions of space.

The sublime and magnificent scenes displayed

in those regions, the diversified objects presented to view; the incessant changes in their phases and aspects; the rapidity of their apparent motions; and the difficulty of determining the *real* motions and relative positions of the bodies in the firmament, and the true system of the world, lead us to the conclusion that the globes to which we allude are replenished, not merely with sensitive, but with *intellectual* beings. For such sublime and interesting scenes cannot affect inanimate matter, nor even mere sentient beings such as exist in our world; and we cannot suppose that the Creator would form such magnificent arrangements to be beheld and studied by *no rational beings* capable of appreciating their grandeur and feeling delight in their contemplation. If creation was intended as a display of the perfections and grandeur of the Divine Being, there must exist intelligent minds to whom such a display is exhibited; otherwise the material universe cannot answer this end, and might, so far as such a design is concerned, have remained forever shut up in the recesses of the Eternal Mind. Such scenes could not have been intended merely for the instruction or gratification of the inhabitants of the earth. For no one of its population has yet beheld them from that point of view in which their grandeur is displayed, and not one out of a hundred thousand yet knows that such objects exist. We are, therefore, irresistibly led to the conclusion that intelligent minds exist in the regions of Jupiter, Saturn, and Uranus, for whose pleasure and gratification these sublime scenes were created and arranged. Those minds, too, in all probability, are endowed with faculties superior in intellectual energy and acumen to those of the inhabitants of our globe. For the rapidity and complexity of the motions presented in the firmament of some of the satellites of Jupiter and Saturn, the variety of objects exhibited to view, and the frequent and rapid changes of their phases and apparent magnitudes, are such as to require the exertion of intellectual faculties more powerful and energetic than ours in order to determine the real motions and positions of the globes around them, and to ascertain the order of the planetary system of which they form a part. And it is likewise probable that their organs of vision are more acute and penetrating than those of men; otherwise they will never be able to discover either the earth, Mars, Mercury, or Venus, and, consequently, may suppose that such bodies have no existence.

#### SECTION V.

**ARGUMENT V.** The doctrine of a plurality of worlds may be argued from the consideration that, in the world we inhabit, *every part of nature is destined to the support of animated beings.*

There is, doubtless, a certain degree of pleasure in contemplating the material world, and surveying the various forms into which matter has been wrought and arranged, particularly in the admirable structure and movements of systems of bodies such as those which compose the planetary system. But there is something still more interesting and wonderful presented to the mind when we contemplate the worlds of life. The material world is only, as it were, the shell of the universe, the mere *substratum* of thought and sensation; living beings are its inhabitants, for whose sake alone matter is valuable, and for whose enjoyment it appears to have been created. In the or-

ganization of animated existences, in the various parts of which they are composed, in the adaptation of one part or organ to another, in their different functions, and the multifarious movements of which they are susceptible, without taking into consideration the soul that animates them, there is a display of the most admirable mechanism and the nicest contrivance, which is not to be found in earth or stones, in rocks of diamonds, or even in the figure of a planet and its motion round the sun.

Hence we find that the world in which we live teems with animated existence. Man is the principal inhabitant, for whose use and accommodation, chiefly, the terraqueous globe was formed and arranged. Had not the Creator intended to place upon its surface beings endowed with rational faculties, capable of enjoying happiness and recognizing the perfections of its author, it is not probable that it would have been created.—“God made man in his own image,” “and gave him dominion over the fish of the sea, over the fowls of the air, and over every living thing that moveth upon the earth.” After the light was formed, the bed of the ocean prepared, and the waters separated from the dry land; after luminaries were placed in the firmament, and plants and animals of all kinds brought into existence, the world appeared so magnificently adorned that it might have been thought perfect and complete. But all nature was yet destitute of sentiment and gratitude; there were no beings capable of recognizing the Power that formed them, or of praising the Author of their varied enjoyments. The world was still in a state of imperfection, until an intelligence was formed capable of appreciating the perfections of the Creator, of contemplating his works, and of offering to him a tribute of grateful adoration. Therefore “God created man in his own image,” as the masterpiece of creation, the visible representative of his Maker, and the subordinate ruler of this lower world.

But although this globe was created chiefly for the residence of man, it was not destined *solely* for his enjoyment. It is impossible for him to occupy the *whole* of its surface, or of the appendages with which it is connected. There are extensive marshes, impenetrable forests, deep caverns, and the more elevated parts of lofty mountains, where human feet have never trod. There is a vast body of water which covers more than two-thirds of the surface of the globe, and the greater part of the atmosphere which surrounds the earth, which men cannot occupy as permanent abodes. Yet these regions of our world are not left destitute of inhabitants. Numerous tribes of animals range through the uncultivated deserts, and find ample accommodation suited to their nature, in rocks and mountains, in dens and caves of the earth.—The regions of the air are filled with winged creatures of every kind, from the ostrich and the eagle to the numerous tribes of flying insects almost invisible to the unassisted eye. The ocean teems with myriads of inhabitants which no man can number, of every form and size, from the mighty whale to the numerous tribes of *Medusæ*, of which several thousands of *billions* are contained in a cubical mile of water. Every sea, lake, and river is peopled with inhabitants; every mountain and marsh, every wilderness and wood, is plentifully stocked with birds and beasts, and numerous species of insects, all of which find ample accommodation, and everything necessary for their comfort and subsistence. In short, every part of matter appears to be peopled; almost every green leaf and every particle of dust has its peculiar

inhabited. Not only are the larger parts of nature occupied with living beings, but even the most minute portions of matter teem with animated existence. Every plant and shrub, and almost every drop of water, contains its respective inhabitants. Their number, in some instances, is so great, and their minuteness so astonishing, that thousands of them are connected within a space not larger than a grain of sand. In some small pools covered with a greenish scum, of only a few yards in extent, there are more living creatures than there are human beings on the surface of the whole earth.

Multitudes of animated beings are found in situations and circumstances where we should never have expected to perceive the principle of life. The juices of animals and plants, corrupted matter, excrements, smoke, dry wood, the bark and roots of trees, the bodies of other animals, and even their entrails, the dung-hill, and the dirty puddle, the itch, and other disorders which are attended with blotches and pimples, and even the hardest stones and rocks, serve to lodge, and in some measure to feed numerous tribes of living beings. The number of such creatures exceeds all human calculation and conception. There may be reckoned far more than a hundred thousand species of animated beings, many of these species containing individuals to the amount of several hundreds of times the number of the human inhabitants of our globe. It is supposed by some that the tremulous motion observed in the air during summer may be produced by millions of insects swarming in the atmosphere; and it has been found that the light which is seen on the surface of the ocean during the nights of summer is owing to an innumerable multitude of small luminous worms or insects sporting in the waters. All the numberless species of animals which exist on the different departments of our globe are likewise infinitely diversified in their forms, organs, senses, members, faculties, movements, and gradations of excellence. As Mr. Addison has observed, "the whole chasm of nature, from a plant to a man, is filled up with divers kinds of creatures rising one above another by such a gentle and easy ascent, that the little transitions and deviations from one species to another are almost insensible. This intermediate space is so well husbanded and managed, that there is scarce a degree of perception which does not appear in some one part of the world of life." Here we have an evidence both of the infinite wisdom and intelligence of the Divine Being, and of his boundless goodness in conferring existence and happiness on such a countless multitude of percipient beings.

Since, then, it appears that every portion of matter in our world was intended for the support and accommodation of animated beings, it would be absurd in the highest degree, and inconsistent with the character of the Deity and his general plan of operation, to suppose that the vast regions of the planets, so exceedingly more expansive than our globe, are left destitute of inhabitants.— Shall one small planet be thus crowded with a population of percipient beings of all descriptions, and shall regions four hundred times more expansive be left without one living inhabitant? Can the Deity delight to communicate enjoyment in so many thousands of varied forms to unnumbered myriads of sensitive existences in our terrestrial sphere, and leave the noblest planets of the system without a single trace of his benevolence? Can we suppose, for a moment, that while his wisdom shines so conspicuous in the mechanism of the various tribes of animals around us, no

similar marks of intelligence are to be found in other regions of the universe? Such conclusions can never be admitted, unless we suppose that infinite wisdom and goodness have been exhausted in the arrangements which have been made in relation to our world, or that the Great Source of felicity is indifferent about the communication of happiness.

As far as our observation extends, it appears that the material world is useless, except in the relation it bears to animated and intellectual beings. Matter was evidently framed for the purpose of mind; and if we could suppose that the vast masses of matter in the heavens had no relation to mind, they must, then, have been created in vain; a supposition which would derogate from the moral character and the perfections of Him who is "the only wise God." A superior nature cannot be supposed to be formed for the sake of an inferior. A skillful artist would never think of designing that which is of the greatest dignity, or which requires the utmost precision and the nicest mechanism, for the sake of the inferior part of his workmanship. He does not construct the wheels and pinions of an orrery for the sake of the handle by which they are moved, or of the pedestal on which the instrument stands; nor does he contrive a timepiece merely for the sake of the shell or case in which it is to be inclosed. In like manner, we cannot imagine that man was made for the sake of the brutes, or the inferior animals for the sake of vegetables, or the yearly production of vegetables for the relief and comfort of the soil on which they grow. This would be to invert the order of the universe, and to involve us in the most palpable absurdity. The order of things always rises upward, by gentle and regular degrees, from inanimate matter, through all the gradations of vegetable, animal, and immaterial existence, until we arrive at the Eternal and Incomprehensible Divinity. Hence it appears that the earth must have been formed, not for itself, but for the sake of the vegetable, sensitive, and intellectual beings it supports; and, by a parity of reasoning, the planets, most of which are much more spacious and more magnificently adorned, must have been formed and arranged for the sake of superior natures.

"Existence," as a certain writer has observed, "is a blessing to those beings only which are indued with perception, and is, in a manner, thrown away upon dead matter, any further than as it is subservient to beings which are conscious of their existence." Accordingly we find, from the bodies which lie under our observation, that matter is only made as the basis and support of living beings, and that there is little more of the one than what is necessary for the existence and the ample accommodation of the other. The earth, as to amplitude of space, would contain a hundred times the number of animated beings it actually supports; and the ocean might perhaps contain thousands more than what are found amid its recesses; but, in such a case, they would not have free scope for their movements, nor experience all the comforts and accommodations they now enjoy.

From what has been stated, it appears that the Divine Goodness is of so communicative a nature that it seems to delight in conferring existence and happiness on every order of perceptive beings, and therefore, has left no part connected with the world in which we live without its inhabitants; and that no creature capable of feeling the pleasure of existence might be omitted in the plan of benevolence, there is an almost infinite diversity

in the rank and order of percipient existence.—The scale of sensitive being begins with those creatures which are raised just above dead matter. Commencing at the polypus and certain species of shell-fish, it ascends by numerous gradations until it arrives at man. How far it may ascend beyond this point is beyond the limits of our knowledge to determine. Had only one species of animals been created, none of the rest would have enjoyed the pleasures of existence. But in the existing state of things, all nature is full of enjoyment, and that enjoyment endlessly diversified, according to the rank and the percipient powers of the different species of animated existence. It would, therefore, be a reflection on the *goodness* as well as on the wisdom of the Divine Being, were we to suppose that no traces of Divine beneficence were to be found amid the expansive regions of the planetary globes. It would form a perfect *contrast* to the operations of Infinite Benevolence, as displayed in our terrestrial system, and would almost lead us to conclude that the same Almighty Agent did not preside in both these departments of the universe. But we may rest assured that the Deity always acts in harmony with his character throughout every part of his dominions; and, therefore, we may confidently conclude that countless multitudes of sensitive and intellectual beings, far more numerous and diversified than on earth, people the planetary regions.

From what has been stated on this subject, we may likewise conclude with certainty that the planetary worlds are not peopled merely with animal existences, but also *with rational and intellectual natures*. For the scenes displayed in most of the planets cannot be appreciated by mere sensitive beings, nor are they calculated to afford them any gratification. Beside, if it be one great design of the Creator to manifest the glory of his perfections to other beings, none but those who are furnished with rational faculties are capable of recognizing his attributes as displayed in his works, and of offering to him a tribute of thanksgiving and adoration. Such intelligences, we have every reason to believe, may far surpass the human race in their intellectual powers and capacities. There is an infinite gap between man and the Deity, and we have no reason to believe that it is entirely unoccupied. There is a regular gradation from inanimate matter and vegetative life through all the varieties of animal existence until we arrive at man. But we have no reason to believe that the ascending scale terminates at the point of the human faculties, unless we suppose that the soul of man is the most perfect intelligence next to the Divinity. If the scale of being rises by such a regular process to man, by a parity of reasoning we may suppose that it still proceeds gradually through those beings that are endowed with superior faculties; since there is an immensely greater space between man and the Deity than between man and the lowest order of sensitive existence. And although we were to conceive the scale of *intellectual* existence above man rising thousands of times higher than that which intervenes between inanimate matter and the human soul, still there would be an infinite distance between the highest created intelligence and the Eternal Mind which could never be overpassed. It is quite accordant with all that we know of the perfections and operations of the Deity to conclude that such a progression of intellectual beings exists throughout the universe; and, therefore, we have reason to believe that in

some of the planets of our system there are intellectual natures far superior, in point of mental vigor and capacity, to the brightest geniuses that have ever appeared upon earth; and in other systems of creation the scale of spiritual progression may be indefinitely extended far beyond the limits to which human imagination can penetrate. In the contemplation of such scenes of percipient and intelligent existence, we perceive no boundaries to the prospect; the mind is overwhelmed amid the immensity of being, and feels itself unable to grasp the plans of Eternal Wisdom, and the innumerable gradations of intelligence over which the moral government of the Deity extends; and, therefore, we may justly conclude wonders of power, wisdom, and benevolence still remain for the admiration of intellectual beings, which the scenes of eternity alone can disclose.

Intellectual beings may likewise be distinguished into those which are linked to *mortal*, and those which are connected with *immortal* bodies. In the present state of our terrestrial system immortal bodies cannot exist. Had immortality been intended for man on earth, Infinite Wisdom would have adopted another plan; for the constitution of the earth, the atmosphere, and the waters, is not adapted to the support and preservation of immortal beings; that is, of those intelligences which inhabit a system of corporeal organization. From the reciprocal action of solids and fluids, of earth, air, and water, *life* results; and this very action continued, according to the laws which now operate, is the natural cause of *death*, or the dissolution of the corporeal system. But in other worlds a system of means may be adapted for preserving in perpetual activity, and to an indefinite duration, the functions of the corporeal machine which is animated by the intellectual principle; as would probably have happened in the case of man, had he retained his original moral purity and his allegiance to his Maker. Intelligent beings may likewise exist which are destined to pass from one state of corporeal organization to another, in a long series of changes, advancing from one degree of corporeal perfection to another, until their organical vehicles become as pure and refined as light, and susceptible of the same degree of rapid motion. The butterfly is first an egg, then a worm, afterward it becomes a chrysalis, and it is not before it has burst its confinement, that it wings its flight, in gaudy colors, through the air. Man is destined to burst his mortal coil, to enter a new vehicle, and at last to receive a body "incorruptible, powerful, glorious, and immortal."—Varieties analogous to these may exist throughout other regions of the universe. If there are not in nature two leaves precisely alike, or two trees, two cabbages, two caterpillars, or two men and women exactly similar in every point of view in which they may be contemplated, how can we suppose that there can be two planets or two systems of planets exactly alike, or that the corporeal organs and faculties of their inhabitants in every respect resemble each other? Every globe and every system of worlds has doubtless its peculiar economy, laws, productions, and inhabitants. This conclusion is warranted from all that we know of the operations of the Creator; it exhibits, in a striking point of view, the depths of his wisdom and intelligence, and it opens to immortal beings a prospect boundless as immensity, in the contemplation of which their faculties may be forever exercised, and their views of the wonders of Creating Power and wisdom continually extending, while myriads of ages roll away.

In the preceding pages I have endeavored to illustrate the doctrine of a plurality of worlds, from the considerations that there are bodies in the planetary system of such *magnitudes* as to afford ample scope for myriads of inhabitants; that there is a *general similarity* among all the bodies of the system, which affords a presumptive evidence that they are intended to subservise the same ultimate designs; that, connected with the planets, there are *special arrangements* which indicate their *adaptation* to the enjoyment of sensitive and intellectual beings; that the *scenery of the heavens, as viewed from the surfaces of the larger planets and their satellites*, forms a presumptive proof of the same position; and that the fact that *every part of nature in our world is destined to the support of animated beings*, affords a powerful argument in support of this doctrine. These arguments, when viewed in all their bearings, and in connection with the wisdom and benevolence of the Divine Being, may be considered as amounting to moral demonstrations that the planets and their satellites, as well as other departments of the universe, are the abodes of sensitive and intellectual natures. These, however, are not all the considerations or arguments which might be brought forward in proof of this position. Many others, founded on a consideration of the nature and relations of things, and the attributes of the Divinity, and particularly some powerful arguments derived from the records of Revelation, might have been stated and particularly illustrated. But I shall leave the further consideration of this topic to another volume, in which we shall take a survey of the scenery of the starry firmament, and of other objects connected with the science of the heavens.

On the whole, the doctrine of a plurality of worlds is a subject of considerable importance, and in which every rational being, who is convinced of his immortal destination, is deeply interested. It opens to our view a boundless prospect of knowledge and felicity beyond the limits of the present world, and displays the ineffable grandeur of the Divinity, the magnificence of his

empire, and the harmonious operation of his infinite perfections. Without taking this doctrine into account, we can form no *consistent* views of the character of Omnipotence and of the arrangements which exist in the universe. Both his wisdom and his goodness might be called in question, and an idea of the Supreme Ruler presented altogether different from what is exhibited by the inspired writers in the records of Revelation.—When, therefore, we lift our eyes to the heavens, and contemplate the mighty globes which roll around us; when we consider that their motions are governed by the same common laws, and that they are so constructed as to furnish accommodation for myriads of perceptive existence, we ought always to view them as the abodes of intelligence and the theaters of Divine Wisdom on which the Creator displays his boundless beneficence; for “his tender mercies,” or the emanations of his goodness, “are diffused *over all his works.*” Such views alone can solve a thousand doubts which may arise in our minds, and free us from a thousand absurdities which we must otherwise entertain respecting the Great Sovereign of the universe. Without adopting such views, the science of the heavens becomes a comparatively barren and uninteresting study, and the splendor of the nocturnal sky conveys no ideas of true sublimity and grandeur, nor is it calculated to inspire the soul with sentiments of love and adoration. In short, there appears to be no medium between remaining in ignorance of all the wonders of Power and Wisdom which appear in the heavens, and acquiescing in the general views we have attempted to illustrate respecting the economy of the planets, and their destination as the abodes of reason and intelligence. But, when such views are recognized, the bodies in the heavens become the noblest objects of human contemplation, the Deity appears invested with a character truly amiable and sublime, and a prospect is opened to immortal beings of a perpetual increase of knowledge and felicity, throughout all the revolutions of an interminable existence.

## A P P E N D I X .

### PHENOMENA OF THE PLANETS FOR THE YEARS 1838, 1839.

FOR the sake of those readers who may feel a desire occasionally to contemplate the heavens and to trace the motions of the planetary orbs, the following sketches are given of the positions and motions of the planets for two years posterior to 1837.

#### POSITIONS, ETC., OF THE PLANETS FOR 1838.

##### 1. *The Planet Mercury.*

This planet can be seen distinctly by the naked eye only about the time of its greatest elongation; and to those who reside in northern latitudes it will scarcely be visible, even at such periods, if it be near the utmost point of its southern declination.

The following are the periods of its greatest elongation for 1838: January the 3d it is at its

eastern elongation, when it is  $19\frac{1}{4}$  degrees east from the sun, and will be seen in the *evening* about thirty or forty minutes after sunset, near the southwest, at a little distance from the point where the sun went down. But as it is then in  $20^{\circ} 41'$  of south declination, its position is not the most favorable for observation. Its next greatest elongation is on February 12, when it is  $26^{\circ} 10'$  to the west of the sun, and will be seen in the *morning*, before sunrise, near the south-eastern quarter of the horizon. April 25 it will again be seen in the *evening* at the eastern elongation,  $20^{\circ} 23'$  east of the sun, when it is in  $21^{\circ} 43'$  of north declination. It will be seen at this time about 15 degrees north of the western point of the horizon, almost immediately above the place where the sun went down. During five days before and after the time now specified there will be favorable opportunities for detecting Mercury with the naked eye or with a small opera-glass. On June 12 is its greatest

*western* elongation, at which time it is  $23^{\circ} 5'$  west of the sun, and is to be looked for in the *morning*, before sunrise, near the north-eastern part of the horizon; but the strong twilight at this season will probably prevent it from being distinguished by the naked eye. Its next greatest *eastern* elongation is on August 23, when it is  $27\frac{1}{4}$  degrees from the sun. It will be seen, for nearly an hour after sunset, a little to the south of the *western* point of the compass, and a few degrees above the horizon. It may be seen during ten or twelve days before the period here stated, and six or eight days after it. This will form one of the most favorable periods which occur throughout this year for observing Mercury. October 4 it will again be at its greatest *western* elongation, when it will be seen in the *morning* in a direction nearly due east. December 17 it is at its greatest *eastern* elongation, but its southern declination being then more than 24 degrees, it will set in the S. W. by S. point of the compass a few minutes after the sun, and will consequently be invisible to the naked eye.

The periods most favorable for detecting this planet in the *evenings* are April 25 and August 23; and in the *mornings*, February 12 and October 4. During the interval of a week or ten days, both before and after the time of greatest elongation, the planet may generally be seen in a clear sky, when in such favorable positions as those now stated.

## 2. The Planet Venus.

This planet will appear as an evening star during the months of January and February. About the beginning of January it will be seen near the south-west quarter of the heavens a few minutes after sunset. About the beginning of February it will set nearly due west. It will be visible in the evening until about the 25th of February, after which its nearness to the sun will prevent it from being distinguished. Throughout the whole of its course during these two months it will appear of the figure of a crescent when viewed with a telescope, and the crescent will appear most slender about the end of February (see Fig. 12, p. 31). On March 5 it passes its *inferior* conjunction with the sun, after which it will be no longer seen in the evenings for the space of ten months. It then becomes a morning star; and, about eight days after its conjunction, will be seen in the *morning*, before sunrise, a little to the south of the eastern point of the horizon. From this period until near the middle of May it will appear of a crescent form. Its greatest brilliancy will be on April 10; its greatest elongation from the sun on May 14, when it will appear of nearly the form of a half moon, and its *superior* conjunction on December 18, soon after which it will again be seen as an evening star.

The brilliancy of this planet is such that it can scarcely be mistaken by any observer, especially when its position in the heavens is pointed out.

## 3. The Planet Mars.

This planet will not be much noticed by common observers until near the end of the year.—About the beginning of March it is in conjunction with the sun, when it is farthest from the earth, about a month or two before and after which period it is scarcely distinguishable from a small star. From April to December it will be visible only in the *morning*, in an easterly direction; but its apparent size will gradually increase until the end of the year. It is distinguished

from the fixed stars and from the other planets by its ruddy appearance.

## 4. The Planets Vesta, Juno, Ceres, and Pallas.

These planets are not perceptible by the naked eye. The best time for observing them with telescopes is when they are at or near the period of their opposition to the sun, when they are nearest to the earth, and even then it will be difficult to detect them without the assistance of transit or equatorial instruments.

*Vesta* will be in opposition to the sun on the 29th December, its right ascension being 6h. 31' 47", and its declination  $22^{\circ} 41\frac{1}{2}'$  north. At midnight it will be due south, at an elevation of 60 degrees above the horizon, in the latitude of 52 degrees north, about 15 degrees to the south-west of the star Pollux, and  $7\frac{1}{2}$  degrees north of *Gama* Gemini.

*Juno* is in opposition on the 17th June, in right ascension 17h.  $46\frac{1}{2}'$ , and south declination  $41\frac{1}{2}^{\circ}$ . It will be on the meridian at midnight, at an elevation of  $33\frac{1}{2}$  degrees above the southern horizon.

Neither *Ceres* nor *Pallas* will be in opposition to the sun during this year.

## 5. The Planet Jupiter.

This planet will make a very conspicuous appearance in the heavens during the winter and spring months. About the beginning of January it will rise, a little to the north of the eastern point of the horizon, a few minutes after ten o'clock in the evening, and will pass the meridian, at an elevation of  $43\frac{1}{2}$  degrees, about half past four in the morning. About the middle of February it will rise about seven in the evening, nearly in the same direction, and will come to the meridian about half past one in the morning.—During the months of January and February it will be seen either in the evenings or the mornings. About the middle of January it will be seen, in a south-westerly direction, about six o'clock in the morning. From the beginning of March until the end of August it will be seen in the evenings without interruption when the sky is clear. On the 22d September it is in conjunction with the sun, but it will seldom be noticed for a month before this period. During the months of November and December it will be again seen in the east, only in the morning, some time before the rising of the sun.

This planet can scarcely be mistaken, as it is next to Venus in apparent magnitude and splendor. It will appear most brilliant about the beginning of March, when it is in opposition to the sun, and its satellites and belts will present an interesting sight when viewed with a good telescope. At present (November 22, 1837), four belts, nearly equidistant from each other, are distinctly visible with a power of 200 times. Their appearance is very nearly similar to what is represented in Fig. 56, p. 64, so that a considerable change has taken place in their appearance since last June, when they appeared nearly as in Fig. 52, p. 61. At that time the middle belt was the only one easily perceptible, while the other two, at the north and south extremities, appeared extremely faint and obscure. At present all the four belts are distinctly marked.

## 6. The Planet Saturn.

This planet passed its conjunction with the sun on the 12th November, 1837. From the begin-

ning of the year until about the middle of April it will be visible chiefly in the mornings. On the first of January it will rise near the south-east, about twenty minutes past four in the morning, and will pass the meridian about forty-eight minutes past eight, at an elevation of 21 degrees above the southern horizon. On the first of April it will rise at half past ten in the evening, and about midnight will be seen near the south-east about ten or twelve degrees above the horizon. From this period Saturn will be visible in the evenings until near the end of October, rising every evening at an earlier hour than on the preceding. On the 16th May it is in opposition to the sun, when it will rise near the south-east at half past seven, and come to the meridian at midnight. During the months of August, September, and October, it will be seen chiefly in the *south-west* quarter of the heavens after sunset, at a small elevation above the horizon. It will be very perceptible during September and October, on account of its low altitude at sunset. It will be in conjunction with the sun on the 24th November.

This planet is not distinguished for its brilliancy to the naked eye, though it exhibits a beautiful appearance through the telescope. It is of a dull leaden color, and is not easily distinguished from a fixed star except by the steadiness of its light, never presenting a twinkling appearance as the stars do, and from which circumstance it may be distinguished from neighboring stars. The best times for telescopic observations on this planet will be in the months of April and May, when its ring will appear nearly as represented in Fig. 63, p. 71.

### 7. The Planet Uranus.

This planet is, for the most part invisible to the naked eye. The best time for detecting it by means of a telescope, is when it is at or near the period of its opposition to the sun, which happens on the 3d September. At that time it passes the meridian at midnight, at an elevation of about  $30\frac{1}{2}$  degrees above the horizon. It is situated nearly in a straight line between the star *Fomalhaut* on the south and *Markab* on the north, being nearly in the middle of the line, about  $22\frac{1}{2}$  degrees distant from each. It is in the neighborhood of several telescopic stars. On account of its slow motion, its position in respect to the above stars will not be much altered for a month or two. On the 1st of November it passes the meridian at eight o'clock in the evening. Its *right ascension*, or distance from the first point of Aries, is then 22h. 42' and its declination  $9^{\circ} 4'$  south.

N. B.—In the above statements the observer is supposed to be in fifty-two degrees north latitude. In places a few degrees to the north or south of this latitude, a certain allowance must be made for the times of rising, and the altitudes which are here specified. To those who reside in lower latitudes than fifty-two degrees, the altitudes of the different bodies will be *higher*, and to those in higher latitudes the altitudes above the horizon will be *lower* than what is here stated.

## PHENOMENA OF THE PLANETS FOR 1839.

### 1. Mercury.

The greatest *western elongation* of this planet happens on the 26th of January, when it is  $21^{\circ} 50'$

west of the sun. It will be seen near the south-east a little before seven in the morning. On the seventh of April, and a few days before and after it, it will be seen in the evening in a direction west by north. On the 24th of May it will be seen in the morning, in a direction a little to the north of the eastern point, before sunrise. Its next elongation will happen on the fifth of August, when it is twenty-seven and one-third degrees distant from the sun. At this period, and a fortnight before and a little after, it will be seen near the west point, or a little north of it, about nine o'clock in the evening or a few minutes before it. This will be a favorable opportunity for distinguishing this planet with the naked eye. It will be again seen in the morning, about five o'clock, a little to the north of the east point, on September 18. Its next greatest elongation will be on the 30th of November, when it will appear in a direction south-west-by-south about the time of sunset. This will be a very unfavorable position for attempting to distinguish Mercury. It passes its inferior conjunction with the sun on the 18th December.

### 2. Venus.

This planet will be an evening star from the beginning of the year until 6th October, when it passes its inferior conjunction with the sun. It will not, however, be much noticed until about the beginning of March, on account of its nearness to the sun and its southern declination. It will appear most brilliant during the months of May, June, July, August, and beginning of September, when it will be seen at a considerable elevation in the western and north-western quarter of the heavens a few minutes after sunset. About the middle of October, or a few days before, it will appear as a *morning star* near the *south-eastern* quarter of the sky, and will continue as a *morning star* until near the end of the year.

### 3. Mars.

During the months of February, March, and April, this planet will appear in its greatest luster. It will be in opposition to the sun on the 12th March, at which period it is nearest to the earth, and will appear twenty-five times larger in surface than in the opposite part of its orbit. At this period it will rise about half past five in the evening, a little to the north of the *east* point, and will come to the meridian at midnight, at an altitude of forty-five degrees. It will be easily distinguished from the neighboring stars by its size and its ruddy appearance. At this time the planet Jupiter will appear in a direction about twenty-two degrees south-east of Mars. From the month of May until the end of the year Mars will be visible in the evenings, but its apparent size will be gradually diminishing, and, on account of its southern declination, will not be much noticed after the month of September. On the 19th July, at forty-six minutes past nine o'clock in the evening, Mars and Jupiter will be in conjunction, at which time Mars will be one degree and a half to the south of Jupiter. They will then be seen near the western point, at a small elevation above the horizon.

### 4. Vesta, Juno, Ceres, and Pallas.

*Juno* arrives at its opposition to the sun on the 12th October, at 1h. 32', p. m. It passes the meridian at midnight, or at 12h.  $2\frac{1}{2}'$ , at an altitude of

$34^{\circ} 21'$ , and is then about twelve degrees west of the star *Mira*. Declination  $3^{\circ} 39'$  south, and right ascension, 1h.  $26'$ .

*Pallas* is in opposition to the sun April 1, at 7h.  $10'$ , A. M. Right ascension 13h.  $12' 43''$ . Declination  $14^{\circ} 21'$  north. It passes the meridian at midnight, at an elevation of  $52^{\circ} 22'$ . It will then be about fourteen degrees south-west from the bright star *Arcturus*.

*Ceres* is in opposition April-6, at 7h.  $8'$ , P. M. Right ascension 13h.  $23' 40''$ . Declination  $7^{\circ} 54'$  north. It passes the meridian at midnight, at an altitude of nearly forty-six degrees. It will then be seen, by means of a telescope, at about twelve degrees south-west from *Arcturus*.

The planet *Vesta* is not in opposition to the sun this year.

### 5. *Jupiter*.

During the months of January and February this planet will be chiefly seen in the morning. On the 12th January it rises about midnight, a little to the south of the eastern point of the horizon, and comes to the meridian at forty minutes past five in the morning, at an altitude of about thirty-two degrees. On the 12th March it rises at eight in the evening, and will be seen near the south-east part of the heavens about eleven and twelve o'clock, P. M. On the 3d April, it is in opposition to the sun, when it rises about half past six, P. M., and comes to the meridian about midnight. From this period it will form a conspicuous object in the evening sky until near the end of September. It arrives at its conjunction with the sun on the 22d October, after which it will be seen only in the morning throughout the month of December and the latter part of November. On the 20th March, at one o'clock in the morning, all the satellites of *Jupiter* will appear on the east, or right-hand side of the planet, in the order of their distances from *Jupiter*. The same phenomenon will happen on August 1, at forty-five minutes past eight, and 20th September, at 7h., P. M.

### 6. *Saturn*.

This planet will be visible only in the morning during the months of January, February and March, and will then be seen toward the southern and south-eastern parts of the sky. On the first of February it will rise, about half past two in the morning, near the south-east, and will come to the meridian at forty-nine minutes past seven, at an elevation of eighteen degrees above the horizon. On the first of April it will rise at forty-two minutes past eleven in the evening, and will pass the meridian a few minutes before four in the morning. It will be in opposition to the sun on

the 29th May, when it will rise in the south-east at forty-five minutes past seven, P. M., and will pass the meridian at midnight, at an altitude of eighteen and a half degrees above the southern point of the horizon. This will be a favorable opportunity for viewing its ring with good telescopes, when it will appear nearly in its full extent, as represented Fig. 65, p. 71. From this period *Saturn* will generally be visible in the evening until about the end of October, when its low altitude and its proximity to the sun will prevent its being distinguished by the naked eye. About the middle of August, at nine o'clock in the evening, it will be seen near the south-west at a small elevation above the horizon. It will be in conjunction with the sun on the fifth December, after which it will be invisible to the naked eye until the beginning of 1840.

### 7. *Uranus*.

This planet will be in opposition to the sun on the 7th of September, at 30 minutes past seven in the evening. Right ascension 23h.  $4'$ , or  $346^{\circ}$  east from the point *Aries*, reckoned on the equator. South declination  $6^{\circ} 52\frac{1}{2}'$ . It will come to the meridian at midnight at an elevation of  $31^{\circ} 8'$  above the horizon. At this time it is in the immediate vicinity of the star *Phi*, *Aquarii*. On the 25th of August, at 20 minutes past one in the morning, it is in conjunction with this star, being only  $15'$  or one-quarter of a degree to the north of it, at which time the planet and the star, if viewed with a telescope of moderate power, will both appear in the field of view. The months of August, September, October, and November will be the most eligible periods for detecting this planet with the telescope. On the 1st of November it passes the meridian at 15 minutes past eight in the evening, at an altitude of  $30\frac{1}{2}$  degrees.

N. B.—The preceding descriptions of planetary phenomena are chiefly intended to inform common observers as to the seasons of the year when the different planets may be seen, and the quarters of the heavens to which they are to direct their attention in order to distinguish them.

It may not be improper to observe, that the planets in general cannot be distinguished by the naked eye for about a month before and after their conjunctions with the sun, except *Venus*, which may frequently be seen within a week before and after its inferior conjunction. But this planet will sometimes be invisible to the naked eye for a month or two after its superior conjunction with the sun.

Should the above descriptions of celestial phenomena prove acceptable to general readers, they may be continued in future years.



THE  
S I D E R E A L H E A V E N S  
AND  
OTHER SUBJECTS CONNECTED WITH  
A S T R O N O M Y,

AS ILLUSTRATIVE OF THE CHARACTER OF THE DEITY, AND OF AN  
INFINITY OF WORLDS.

“The worlds were framed by the word of God.”—PAUL.



## P R E F A C E .

---

THE favorable reception which the volume entitled "CELESTIAL SCENERY," has met with from the public, both in Britain and America, has induced the Author to extend his survey to other sublime scenes connected with the science of Astronomy. The chief object of the work alluded to, was to illustrate, more fully than had previously been attempted, the scenes connected with the planetary system. In the present volume, the Author has directed the attention of his readers to scenery of a still more elevated and sublime description, connected with the "Sidereal Heavens." All the facts related to this subject, which can be considered as interesting to general readers, have been particularly detailed, and in such a manner as to be generally comprehensible by those who have little knowledge of mathematical science, or the more abstruse parts of astronomy.

In describing such sublime scenes as are here unfolded, the Author, as on former occasions, has freely indulged in such remarks and moral reflections as were naturally suggested by the grandeur of his subject; and has endeavored to lead the minds of his readers to the contemplation of the attributes and the agency of that Almighty Being, by whom the vast system of universal nature was at first brought into existence, and by whose superintending care it is incessantly conducted in all its movements.

The subject of a plurality of worlds has been resumed, and additional arguments, both from reason and revelation, have been brought forward so as to exhibit this position, not merely as conjectural or highly probable, but as susceptible of moral demonstration. For the gratification of amateur observers possessed of telescopes, particular descriptions have been given of the *positions* or some of the more remarkable phenomena in the sidereal heavens, that they may be induced to contemplate them with their own eyes. For a similar reason, the Author has described the various aspects of the heavens throughout the year, and the position of the planets for 1840 and 1841. As the subject of *comets* was unavoidably omitted in the preceding volume, the Author has condensed, in the concluding chapter, the greater part of the facts which have been ascertained respecting the nature, phenomena, and influence of those anomalous bodies.

It was originally intended, had the limits of the present volume permitted, to direct the attention of the student to other subjects related to the scenery of the heavens, and to the construction and application of some of those instruments which are devoted to celestial observations. Should the work now published meet with a favorable reception, the Author intends—in a smaller volume than the present—to elucidate some of the subjects to which he alludes, especially the following:—the construction and use of optical instruments, particularly the reflecting and achromatic telescope, and the equatorial. As the Author has performed a great variety of experiments in relation to such instruments, he hopes to have it in his power to suggest some new and useful hints in reference to their construction and improvement. The

## PREFACE.

doctrine of eclipses and occultations, the precession of the equinoxes, &c.—the construction of observatories, and the manner of using astronomical instruments,—the *desiderata* in astronomy, and the means by which the progress of the science may be promoted,—the practical utility, physical and moral, of astronomical studies,—their connection with religion, and the views they unfold of the attributes and the empire of the Creator, with several other correlative topics, will likewise be the subject of consideration. The whole to be illustrated with appropriate engravings, many of which will be original.

**BROUGHTY FERRY, NEAR DUNDEE.**

# CONTENTS.

## INTRODUCTION.

	PAGE
Imperfect knowledge of the Sidereal Heavens. Discoveries by the telescope. Herschel's observations. Sidereal science in its infancy. Boundless nature of the subject.....	9

## CHAPTER I.

### A GENERAL VIEW OF THE STARRY HEAVENS, WITH REPRESENTATIONS OF DETACHED PORTIONS OF THE FIRMAMENT.

Splendid and august appearance of the heavens. Sentiments and emotions they produce. Inquiries suggested by a contemplation of the wonders they unfold. Appearance of the stars and constellations about the middle of January. Delineations of certain stars and constellations at that time visible. Representations of certain portions of the heavens in the beginning of September. View and description of the circumpolar stars. General remarks in reference to these stars.....	11
--	----

## CHAPTER II.

### OF THE ARRANGEMENT OF THE STARS INTO CONSTELLATIONS, WITH SKETCHES OF THEIR MYTHOLOGICAL HISTORY.

Invention of the <i>Zodiac</i> . Mode in which it was divided by the ancients. Origin of the names by which its signs are distinguished. List of the constellations, with the number of stars in each. Arrangement of the stars into different magnitudes. Catalogues of the stars. Origin of the celestial hieroglyphics. Greek alphabet.....	18
--	----

## CHAPTER III.

### ON THE PROPRIETY OF ADOPTING A MORE NATURAL ARRANGEMENT AND DELINEATION OF THE STARRY GROUPS.

Introductory remarks. Reasons why the present nomenclature and arrangement of the stars should be changed. Principles on which a new arrangement should be formed. Improvements which might be adopted in the meantime in celestial globes and planispheres. Delineation of Orion. Sir J. Herschel's opinion. British Association.....	23
--	----

## CHAPTER IV.

### ON THE DISTANCES OF THE STARS.

Measures of distance. Annual parallax. Mode of investigating it. Galileo, Hook, and Flamstead's methods. Molyneux's and Bradley's observations. Aberration. Supposed distance of the nearest star. Herschel's investigations. Professor Bessel's determination of the parallax of 61 Cygni. Amazing distance of this star. Reflections on the immense spaces of the universe. Scriptural representations of the Deity. Whether man may ever traverse distant regions.....	27
---	----

## CHAPTER V.

### ON THE MAGNITUDE OF THE STARS.

Difficulty of ascertaining the real and apparent magnitude of the stars	Supposed magnitude (v)
---	---------------------------

of some stars. Certainty that their real magnitudes are very great. Popular illustration of the distances and magnitudes of the stars. ....	33
---	----

## CHAPTER VI.

### ON NEW STARS.

New star discovered by Hipparchus. Particular description of the new star which appeared in 1572—delineation of its position. Description of the new star of 1604, and of several others. Mysterious nature of these bodies. Opinions which have been formed respecting them. Futility of some of these opinions. Such bodies not annihilated. Probable cause of such phenomena. Concluding reflections. ....	36
---	----

## CHAPTER VII.

### ON VARIABLE STARS.

Descriptions of the periods and phenomena of some of these bodies, <i>Stella Mira</i> , <i>Algol</i> , <i>Eta Antinoi</i> , &c. Conjectures respecting their nature. Probable causes of the phenomena of variable stars, illustrated by figures. Stars which are lost. Stars which have changed their magnitudes. Stars which have recently become visible. New creations. Omnipotent energies. Scenes of grandeur in the heavens. ....	41
---	----

## CHAPTER VIII.

### ON DOUBLE STARS AND BINARY SYSTEMS.

Variety a characteristic of the works of the Deity. Double stars observed by Herschel and others—their number—their motions. Herschel's observations on the motion of the double star <i>Castor</i> . Period of revolution illustrated by a diagram. Periods of revolution of several double-stars. Occultation of one star by another. Orbits of double-stars—telescopic views of. Scenes exhibited by the revolutions of double stars. Distances of binary systems. Planets connected with them. Velocity of motions. Number of such systems. Contrasted colors of double stars. Effects produced on planets by colored suns. Representations of a binary system. Proposed method of determining the distances of double stars. General remarks on this method, &c. ....	46
--	----

## CHAPTER IX.

### ON TREBLE, QUADRUPLE, AND MULTIPLE STARS.

General remarks. Treble star in Cancer. Delineation of treble and quadruple systems. Quadruple star in Lyra. Oscillating suns. Problem of three bodies. Reflection on multiple systems. List and positions of treble and multiple stars. ....	51
---	----

## CHAPTER X.

### ON THE MILKY WAY.

Grandeur of the sidereal heavens. Position of the Milky Way, and the constellations through which it passes. Multitude of stars it contains. Sir W. Herschel's observations on this zone. Estimate of the <i>number</i> of stars it may contain. Number of visible stars in the heavens. <i>Distances</i> of some of the stars in this zone. Reflections on the scene exhibited by the Milky Way. Position of our sun in this zone. Delineations of the <i>form</i> of the Milky Way. Schroeter's observations. Herschel's remarks on its structure. Its appearance in the southern hemisphere. ....	51
--	----

## CHAPTER XI.

### ON GROUPS AND CLUSTERS OF STARS.

The <i>Pleiades</i> —telescopic view of—(see <i>Appendix</i> ). Hook and Mitchell's remarks on this cluster. <i>Coma Berenices</i> — <i>Præsepe</i> —telescopic view of. <i>Perseus</i> . Delineation of a group in Orion's	
---	--

sword. Such groups form interesting objects of contemplation—immensity of the universe.	
Views and descriptions of stars. Variety of firmaments.....	62

## CHAPTER XII.

## ON THE DIFFERENT ORDERS OF THE NEBULÆ.

## SECTION I.

## GENERAL REMARKS ON THE SUBJECT OF NEBULÆ.

Boundless extent of the universe. Sir W. Herschel's remarks on this subject. Lambert's views of the universe. Number of discovered nebula. Size, grandeur, and different forms of the nebulae.....	66
--	----

## SECTION II.

## ON THE VARIOUS KINDS OF NEBULÆ.

Clusters of stars. <i>Resolvable</i> nebulae. <i>Irresolvable</i> nebulae. Views and descriptions of various kinds of nebulae—globular—elliptical—annular—spheroidal. Nebulous stars. Diffused nebulosities. Nebulosities joined to nebulae, &c.....	68
--	----

## SECTION III.

## ON PLANETARY NEBULÆ.

General description. Enormous magnitude of such bodies. Positions of some of these nebulae.	73
---	----

## SECTION IV.

## ON NEBULÆ IN ORION.

Its position. Huygens' description of it. Delineations of this nebulae. Herschel's descriptions and remarks. The author's observations. Its immense magnitude. Reflections and remarks..	75
--	----

## SECTION V.

## ON THE NEBULAR HYPOTHESIS.

Inquiries and conjectures suggested by the nebulae. Premature conclusions which have been deduced. Remarks and reflections in relation to the subject of nebulae.....	77
---	----

## SECTION VI.

Catalogue of some of the larger nebulae.....	78
--	----

## CHAPTER XIII.

## ON THE ABERRATION OF THE STARS, AND ON THEIR PROPER MOTIONS.

Bradley and Molyneux's observations. Aberration of light explained and illustrated. Sir J. Herschel's explanation. Other illustrations. Conclusions deduced from the aberration of the stars. Proper motions of the stars when first observed. Specimens of their annual motions. Velocity with which they move.....	81
--	----

## CHAPTER XIV.

## ON THE DESTINATION OF THE STARS; OR, THE DESIGNS THEY ARE INTENDED TO SUBSERVE IN THE SYSTEM OF THE UNIVERSE.

Utility of the stars to our globe. This not the chief design of their creation. Are suns to other worlds. Arguments which prove this position. Constitute the chief part of the universe. Direct indications of their being the centers of systems. Immense extent of the Divine empire..	84
---	----

## CHAPTER XV.

## ON UNKNOWN CELESTIAL BODIES—ON METEORIC PHENOMENA—AND ON SHOOTING STARS.

Probable existence of large opaque globes throughout space. Central bodies. Lambert's views on this subject. Meteoric phenomena. November meteors. Various descriptions of their phenomena, illustrated by a figure. Seen in different parts of the world. Circumstances attending their fall. Their appearance in France. Dr. Olmsted's deductions respecting their origin, illustrated by a diagram. Arago's opinion. General reflections.....	88
--	----

## CHAPTER XVI.

ARGUMENTS ILLUSTRATIVE OF THE DOCTRINE OF A PLURALITY OF WORLDS.

This doctrine accordant with the *infinity*, the *eternity*, the *wisdom*, and the *benevolence* of the Divine Mind. Exhibits a magnificent idea of Deity. Power always accompanied with wisdom and goodness. Absurdities involved in the opposite opinion. Harmony of the Divine Perfections. Summary of arguments..... 94

## CHAPTER XVII.

A PLURALITY OF WORLDS PROVED FROM DIVINE REVELATION

Introductory remarks. Psalm viii, 3, 4. Isaiah xl, 15, 17. Nehemiah ix, 6, &c. Such passages explained and illustrated..... 100

## CHAPTER XVIII.

ON THE PHYSICAL AND MORAL STATE OF THE BEINGS THAT MAY INHABIT OTHER WORLDS.

They are *sentient* beings—endowed with *intellectual* faculties—furnished with *bodies*—with *organs of vision*—locomotive powers. Various other circumstances connected with their existence. Make *progressive* improvement in knowledge. Intercourses among them. Spiritual economy. *Moral state of the inhabitants of other worlds*. Happiness dependent on moral principle and action. Moral order. Moral laws which govern all pure intelligences.. 105

## CHAPTER XIX.

A SUMMARY VIEW OF THE UNIVERSE.

Mental process by which we obtain an approximate idea of creation. Magnitude of the earth. Planetary system. Stars visible to the naked eye. Milky Way. Nebulæ—their extent and grandeur. Immensity of creation. Astonishing motions in the universe. Mode by which we may acquire the most comprehensive idea of it. Creation a proof of the Divine Existence. Attributes of Deity. Dependence of all beings upon God. Christian Revelation..... 113

## CHAPTER XX.

ON COMETS.

Description of the parts of a comet. Opinions of Aristotle, Tycho, &c. History of remarkable comets. Comets of 1680, 1682, 1744, 1770. Encke's comet. Biela's and Gambart's. Alarms occasioned by comets. Comet of 1807—Schroeter's and Herschel's observations on—views of this comet. Comet of 1811—Schroeter's observations and deductions respecting its phenomena—destruction of his Observatory. Reappearance of Halley's comet in 1835—observations on, by the Author, Rev. Mr. Webb, and others. Mrs. Somerville's remarks. *Physical constitution of Comets*—opinions respecting their nuclei and tails. *Miscellaneous remarks respecting comets*—their light, phases, and nebulosity—whether they may come in contact with the earth—whether they have ever fallen into the sun. *On the influence of comets on the earth*—opinions prevalent in former times—Forster's hypothesis. Comets *may have* an influence on our globe—its nature not yet determined. Whether the direction of the earth's axis has been altered by a comet. Whether the new planets were disrupted by the shock of a comet, &c. *On the orbits of comets*—their form—how determined. Motions and periods of. *Number of*. Direct and retrograde motions, inclination of orbits, &c. *Inhabitability of comets*. Size and splendor of some comets. Account of Mr. Webb's MS. Treatise on Comets..... 120

## APPENDIX.

Aspect of the sidereal heavens for every alternate month of the year, with remarks.....	137
Phenomena and positions of the planets for 1840.....	142
Ditto 1841.....	145
Eclipses and occultations 1840.....	147
Ditto 1841.....	147
Occultations of Venus 1841.....	148
Explanations of some of the engravings of the stars and planets.....	149



## THE

# SIDEREAL HEAVENS.

## INTRODUCTION.

IN a work lately published under the title of "CELESTIAL SCENERY," I endeavored to exhibit a pretty full display of all the prominent facts connected with the motions, distances, magnitudes, and other phenomena of the planets, both primary and secondary, and of the observations and reasonings by which they are supported. These bodies forming a part of the solar system to which we belong, and lying within the limits of measurable distance, can be more distinctly surveyed, and their magnitudes and other phenomena more accurately investigated, than those of the remoter orbs of the firmament. Hence, in consequence of the accurate observations of modern times, we can now speak with a degree of certainty and precision respecting their order and arrangement, their periodical revolutions, their distances from the spheres we occupy and from the center of the system, their real bulk, the appearance of their surfaces, and the objects which diversify their respective firmaments. But when we pass the boundary of the planetary system, and attempt to explore the orbs which lie beyond it, we have to travel, as it were, through dark and pathless regions, we have to traverse an immense interval which has hitherto baffled all the efforts of human science and ingenuity to determine its extent. The fixed stars lie completely beyond the dominions of the sun; they feel not his attractive influence, they revolve not around him as a center, nor are they enlightened by his effulgence. It follows that our knowledge of those remote luminaries must be extremely imperfect, and our views of the distant regions in which they are placed comparatively limited and obscure.

But notwithstanding the immeasurable distance of the starry regions, and the limited nature of human vision, we are not altogether ignorant of those remote and unexplored dominions of Omnipotence, or of the magnitude and splendor of the bodies they contain. The telescope has enabled us to penetrate the vast spaces of the universe, and has opened a *vista* through which thousands of suns and systems are distinctly beheld, which would otherwise have been forever veiled from the view of mortals. It has extended the boundaries of our vision thousands of times beyond its natural limits, and collected the scattered rays of light from numerous distant orbs, which, without its assistance, would never have entered our eyes. It has served the purpose of a celestial vehicle to carry us toward the heavens, and has produced the same effect on our visual powers as if we had been actually transported thousands of millions of miles nearer the unexplored territories of creation. Guided by this noble instrument, scenes and objects have been disclosed to view of which former generations could form no conception, and which

lead the reflecting mind to the most elevated views of the perfections of the Deity, and to the most expansive prospects of the grandeur and magnificence of his empire.

For a considerable period after the true system of the world was recognized, astronomers were disposed to consider the stars as so many insulated luminaries, scattered almost at random throughout the vast spaces of the universe. Having engaged in no very extensive surveys of the celestial vault, and resting contented with the idea that the stars were so many suns, dispersed in a kind of magnificent confusion through the immensity of space, they seemed to have formed no conception of any specific difference in the nature of these bodies, or of any systematic arrangement as existing among them. Hence it happened that no discoveries of importance were made in the region of the stars, from the time of Huygens and Cassini until near the latter part of the eighteenth century; so that a whole century elapsed without materially enlarging our views of the sidereal heavens and of the variety, order and arrangement of the numerous bodies which every portion of those expansive regions presents to view. During the last sixty or seventy years, the attention of astronomers has been more particularly directed to sidereal observations; and among those who have labored with success in this department of astronomical investigation, the late Sir William Herschel stands pre-eminent. Fired with a noble zeal for the improvement of his favorite science, and for the enlargement of his views of the distant regions of creation, he set to work with enthusiastic ardor, and constructed with his own hands telescopes of a size and magnifying power far superior to what had ever before been attempted. Mounted on the top of his forty feet reflecting telescope, he not only discovered new bodies within the limits of the planetary system, but brought to light innumerable phenomena in regions of the firmament where the eye of man had never before dared to penetrate. He explored the Milky-way throughout all its profundities, and found that whitish zone of the heavens to consist of a multitude of stars "which no man could number," fifty thousand of them having sometimes passed through the field of his telescope in the space of an hour. During the coldness and profound silence of many sleepless nights, he surveyed almost every portion of the celestial concave, and discovered more than two thousand *nebulae*, or starry systems, of various forms and descriptions, along with multitudes of double, triple, and quadruple stars which had formerly been unknown, and ascertained, from the change of their relative positions, some of their real motions and periods of revolution. After more than half a century spent in unwearied observations of the heavens,

this illustrious astronomer departed from this earthly scene, in 1822, without infirmities and without pain, in the eighty-fourth year of his age, leaving a son to prosecute his labors indued with virtues and talents, worthy of his father, and whose observations and researches have already enriched the science of astronomy, and extended our views of the sidereal system.

This department of astronomical science may be considered as still in its infancy. Years, and even centuries, must roll on, and the number of astronomical observers must be increased a hundred-fold, before the sidereal investigations now going forward can be nearly completed. A more extensive knowledge of the history of the heavens, of the bodies which lie hid in the yet unexplored regions of space, and of the changes and diversified motions to which they are subject, is doubtless reserved for generations to come; and from the attention which has lately been paid to this subject, and the ardor with which it is now prosecuted in different parts of the world, we have reason to expect that new scenes of divine wisdom and omnipotence will be gradually unfolding, and new and interesting results deduced from the nocturnal labors of those who have devoted themselves to celestial investigations. To what extent our knowledge of the objects of this science may yet reach, it is impossible for us to anticipate. The objects in the heavens present a scene which is absolutely boundless,—which all the generations of men that may arise until the termination of our terrestrial system will never be able fully to explore; a scene which will doubtless engage the study and contemplation of numerous orders of intellectual beings throughout all the revolutions of eternity.

In the following work, I propose to give only a very condensed view of the leading objects which have been lately discovered in the sidereal heavens. The facts in relation to this subject will be selected chiefly from the observations of Sir. W. Herschel, and several other astronomers, and some of

them from personal observation. Most of the facts to which I allude were ascertained by Sir W. Herschel by means of telescopes of great size and power, and a considerable number of the double and triple stars, stellar and planetary nebulae, and other phenomena, cannot be perceived with instruments of an ordinary size. Certain interesting facts, too, particularly with regard to the motions of double stars, have lately been brought to light by the observations of Sir John Herschel, made in the southern hemisphere; but the bodies to which I allude cannot be seen in the northern latitudes in which we reside. A considerable portion therefore of our information on this subject must necessarily depend on the observations of the astronomers to whom I allude, and the statements they have published to the world; but these observations have, for the most part been abundantly verified by other observers.

It shall be our endeavor to state the prominent facts connected with the sidereal heavens in as plain and perspicuous a manner as possible; and while it forms no part of our plan to frame hypotheses, or launch out into theoretical disquisitions, we shall offer those remarks, and freely indulge in those moral reflections, which the contemplation of such august objects are calculated to suggest. The scenes we intend to exhibit are not only the workmanship of God, but display the glory of his attributes and the magnificence of his empire in a degree, and upon a scale, far surpassing what can be seen in any other department of creation; and therefore, in all our surveys of those grand and multifarious objects, we ought invariably to connect our views and investigations with the supreme agency of Him who brought them into existence, and to cherish those sentiments and emotions which may inspire us with reverence and adoration of that glorious and incomprehensible Being “by whom the worlds were framed,” “who created all things, and for whose pleasure they are and were created.”

## CHAPTER I.

### A GENERAL VIEW OF THE STARRY HEAVENS, WITH REPRESENTATIONS OF DETACHED PORTIONS OF THE FIRMAMENT.

If we could suppose a community of rational beings to have lived for ages in some subterraneous grottos far beneath the surface of the earth, and never to have visited the exterior portions of our globe, their ideas must have been extremely circumscribed, and their enjoyments extremely imperfect, even although they had been furnished with everything requisite for their animal subsistence. Could we imagine that such beings were all at once transported to the surface of the earth, with what astonishment and wonder would they be seized when they beheld the expansive landscape of the world, the lofty mountains towering to the clouds,—the hills crowned with magnificent forests,—the plains stretching to the boundaries of the horizon, and adorned with colors of every shade,—the expansive lake, like a magnificent mirror, embosomed among the hills,—the rivers rolling their watery treasures toward the ocean,—and the sun in the firmament revolving around the circuit of the sky, diffusing his light and heat on every surrounding object! Above all, with what emotions of admiration would they be filled when they beheld the solar globe descending below the western horizon, and soon after the moon displaying her silver crescent in the sky, and the stars, one after another, emerging from the blue ethereal, until the whole celestial concave appeared all over spangled with a thousand shining orbs, emitting their radiance from every part of the cope of heaven, and all moving, with an apparently slow and silent motion, along the spaces of the firmament! Such expansive and novel scenes would undoubtedly overwhelm the faculties of such beings with astonishment, and transport, and wonder inexpressible.

We are placed, perhaps, in a situation nearly similar in regard to the remote regions of the universe, as the beings we have supposed were situated with respect to the ample prospects we enjoy on the surface of our globe. Were such beings, from their subterranean abodes, to look through a narrow funnel which presented them with a feeble glimpse of our upper world, and of a portion of the sky, the view thus obtained would somewhat resemble the partial glimpse we have yet acquired of the splendor and sublimities of the distant universe; and were we transported to those far distant scenes, which appear through our telescopes only like dim specks of light, we should, doubtless, be as much overpowered with astonishment and wonder at the magnificent scenes which would open to our view, as our supposed subterraneous inhabitants could be at the amplitude and grandeur of our terrestrial abode.

In our present habitation we are confined to a mere point in the infinity of space. Ample as our prospects are, it is not improbable that the views we have already attained bear a less proportion to the whole immensity of creation than the

limited range of a microscopic animalcule bears to the wide expanse of the ocean. What is seen by human eyes, even when assisted by the most powerful instruments, may be as nothing when compared to what is unseen and placed forever beyond the view of mortals. Since the heavens first began to be contemplated, our views have been carried thousands of times further into the regions of space than the unassisted eye could enable us to penetrate; and at every stage of improvement in optical instruments our prospects have been still further extended, new objects and new regions of creation have appeared rising to view, in boundless perspective, in every direction, without the least indication of a *boundary* to the operations of Omnipotence; leaving us no room to doubt that all we have hitherto discovered is but a small and inconsiderable part of the length and breadth, and the height and depth of *immensity*. We may suppose, without the least degree of improbability or extravagance, that, were the whole of the *visible* system of creation annihilated, though it would leave a void immeasurable and incomprehensible by mortals, it would appear to the eye of Omniscience only as an inconsiderable blank scarcely discernible amidst the wonders of wisdom and omnipotence with which it is surrounded.

Such views and deductions have been derived from attentive surveys of the STARRY HEAVENS. These heavens present, even to the untutored observer, a sublime and elevating spectacle. He beholds an immense concave hemisphere, surrounding the earth in every region, and resting, as it were, upon the circle of the horizon. Wherever he roams abroad, on the surface of the land or of the ocean, this celestial vault still appears encompassing the world; and after traveling thousands of miles, it seems to make no nearer an approach than when the journey commenced. From every quarter of this mighty arch numerous lights are displayed, moving onward in solemn silence, and calculated to inspire admiration and awe. Even the rudest savages have been struck with admiration at the view of the nocturnal heavens, and have regarded the celestial luminaries either as the residences of their gods, or the arbiters of their future destinies.

But to minds enlightened with the discoveries of science and revelation the firmament presents a scene incomparably more magnificent and august. Its concave rises toward immensity, and stretches, on every hand, to regions immeasurable by any finite intelligence; it opens to the view a glimpse of orbs of inconceivable magnitude and grandeur, and arranged in multitudes which no man can number, which have diffused their radiance on the earth during hundreds of generations; it opens a vista which carries our views into the regions of *infinity*, and exhibits a sensible display of the *immensity* of space, and of the boundless

operations of Omnipotence; it demonstrates the existence of an eternal and incomprehensible Divinity, who presides in all the grandeur of his attributes over an unlimited empire; it overwhelms the contemplative mind with a display of the riches of his wisdom and the glories of his OMNIPOTENCE; it directs our prospects to the regions of other worlds, where ten thousand times ten thousands of intelligences, of various orders, experience the effects of divine love and beneficence. Amidst the silence and the solitude of the midnight scene, it inspires the soul with a solemn awe and with reverential emotions; it excites admiration, astonishment, and wonder in every reflecting mind, and has a tendency to enkindle the fire of devotion, and to raise the affections to that ineffable Being who presides in high authority over all its movements. While contemplating, with the eye of intelligence, this immeasurable expanse, it teaches us the littleness of man, and of all that earthly pomp and splendor of which he is so proud; it shows us that this world, with all its furniture and decorations, is but an almost invisible speck on the great map of the universe; and that our thoughts and affections ought to soar above all its sinful pursuits and its transitory enjoyments. In short, in this universal temple, hung with innumerable lights, we behold, with the eye of imagination, unnumbered legions of bright intelligences, unseen by mortal eyes, celebrating in ecstatic strains, the perfections of Him who is the creator and governor of all worlds,—we are carried forward to an eternity to come, amidst whose scenes and revolutions alone the magnificent objects it contains can be contemplated in all their extent and grandeur.

It is an evidence of the depraved and groveling dispositions of man that the firmament is so seldom contemplated with the eye of reason and devotion. No other studies can present an assemblage of objects so wonderful and sublime; and yet, of all the departments of knowledge which are generally prosecuted, no one is so little understood or appreciated by the bulk of mankind as the science of the heavens. Were it more generally studied, or its objects were frequently contemplated, it would have a tendency to purify and elevate the soul, to expand and enoble the intellectual faculty, and to supply interesting topics for conversation and reflection. The objects in the heavens are so grand, so numerous, so diversified, and so magnificent, both in their size and in the rapidity of their motions, that there appears no end to speculation, to inquiry, to conjecture, to incessant admiration. There is ample room for all the faculties of the brightest genius to be employed, and to expatiate in all their energy on this boundless theme; and were they thus employed more frequently than they are, our views of the arrangement, and the nature of the magnificent globes of heaven, might be rendered still more definite and expansive.

While contemplating the expanse of the starry heavens, the mind is naturally led into a boundless train of speculations and inquiries. Where do these mighty heavens begin, and where do they end? Can imagination fathom their depth, or human calculations and figures express their extent? Have angels or archangels ever winged their flight across the boundaries of the firmament? Can the highest created beings measure the dimensions of those heavens, or explore them throughout all their departments? Is there a boundary to creation beyond which the energies of Omnipotence are unknown, or does it extend throughout the infinity of space? Is the immense

fabric of the universe yet completed, or is almighty power still operating throughout the boundless dimensions of space, and new creations still starting into existence? At what period in duration did this mighty fabric commence, and when will it be completed? Will a period ever arrive when the operations of creating power shall cease, or will they be continued throughout all the revolutions of eternity? What various orders of intellectual beings people the vast regions of the universe? With what mental energies and corporeal powers are they endowed? Are they confined to one region of space, or are they invested with powers of locomotion, which enable them to wing their flight from world to world? Are they making rapid advances, from age to age, in intellectual improvement? Has moral evil ever made inroads into those remote regions of creation, or are all their inhabitants confirmed in a state of innocence and bliss? Is their history diversified by new and wonderful events, and do changes and revolutions happen among them? Are all the tribes of intellectual natures throughout creation connected together by certain relations and bonds of union, and will a period ever arrive in the future revolutions of eternity when they shall have had an intimate correspondence with one another? These, and hundreds of similar inquiries, are naturally suggested by serious contemplations of the objects connected with the starry heavens, and they have a tendency to lead the mind to sublime and interesting trains of thought and reflection, and to afford scope for the noblest energies of the human soul.

But leaving such reflections, in the meantime, let us now take a general view of the starry heavens as they appear to the eye of a common spectator.

When an untutored observer attempts to take a serious survey of the starry firmament for the first time, he is apt to be bewildered at the idea of the immense multitude of stars which seem to present themselves in every part of the sky, and the apparent confusion with which they seem to be arranged. He is apt to think that they are absolutely innumerable, and that all attempts to enumerate or to classify them would be in vain. There is something so magnificent and overpowering in a cursory view of a clear starry sky, that the mind shrinks from the idea of ever being able to form a distinct conception of the number and order of those luminous orbs, or of their distances and magnitudes; but the genius and industry of man have, in numerous instances, accomplished what at first view appeared beyond the reach of the human faculties. All the stars *visible to the naked eye* have been numbered, and their relative positions determined, with as much precision as the longitudes, latitudes, and bearings of places on the surface of the globe; and there is not a star visible to the unassisted eye, but its precise position can be pointed out, not only during the shades of night, but even during the day, when the sun is shining in all its splendor.

In order to prevent confusion in our first surveys of the starry heavens, let us fix upon a certain portion of the firmament, and the more conspicuous stars which lie in its immediate vicinity. Let us suppose ourselves contemplating the heavens about the middle of January, at eight o'clock in the evening, in the latitude 52° north. At that time, if we turn our faces toward the south, we shall behold the splendid constellation of *Orion* a little to the east of the meridian, or nearly approaching the south. This constellation forms one of the most striking and beautiful

clusters of stars in the heavens, and is generally recognized even by common observers. It is distinguished by four brilliant stars in the form of an oblong, or parallelogram; and particularly by three bright stars in a straight line near the middle of the square, or parallelogram, which are known by the names of "the Three Kings," or the "Ell," or "Yard." They are also termed Orion's *belt*; and in the book of Job, "the bands of Orion;" and the space they occupy is exactly three degrees in length. The line passing through these stars points to the *Pleiades*, or seven stars, on the one side, and to *Sirius*, or the Dog Star, on the other. The equinoctial circle passes through the uppermost of these stars, which is called *Mintika*. They are situated about eight degrees west from the *subsistial colure* or that great circle which passes through the poles of the heavens, and the first points of Cancer and Capricorn, in which the sun is in his greatest declination north and south, which happens on the 21st of June and 21st of December. There is a row of small stars which run down obliquely below the belt, and seem to hang from it, which is denominated the *sword* of Orion. About the middle of this row of stars there is perceived, by means of the telescope, one of the most remarkable *nebulae* in the heavens. The whole number of stars visible by the naked eye in this constellation has been reckoned at about 78; of which two are of the first magnitude—namely, *Rigel*, in the left foot on the west, and *Betelgeuse*, on the east shoulder. They are connected by a line drawn through the uppermost star of the belt. There are four stars of the second magnitude, three of the third, and fifteen of the fourth; but several thousands of stars have been perceived by good telescopes within the limits of this constellation.

North by west of Orion is the constellation *Taurus*, or the Bull, one of the signs of the zodiac. The *Pleiades*, or the seven stars, so frequently alluded to both in ancient and modern times, form a portion of this constellation. At the time now supposed, they are a very little beyond the meridian to the west, and about thirty-seven degrees north by west of the belt of Orion, at an elevation above the horizon of about sixty-four degrees. This cluster was described by the ancients as consisting of seven stars, but at present only six can be distinguished by the naked eye. With powerful telescopes, however, more than 200 stars have been counted within the limits of this group. The *Hyades* is another cluster, situated about eleven degrees south-east from the *Pleiades*, consisting chiefly of small stars, so arranged as to form a figure somewhat like the letter V. On the left, at the top of the letter, is a star of the first magnitude, named *Aldebaran*, or the Bull's Eye, which is distinguished from most of the other stars by its *ruddy* appearance. This constellation is situated between *Persens* and *Auriga* on the north, and has *Gemini* on the east, *Aries* on the west, and *Orion* and *Eridanus* on the south. It consists of about 140 stars visible to the naked eye.

The constellation *Gemini* is situated north-east from Orion, and almost due east from the *Pleiades*, and is one of the signs of the zodiac. It has *Cancer* on the east, *Taurus* on the west, and the *Lynx*, on the north. The orbit of the earth, or the apparent circle described by the sun in his annual course, passes through the middle of this constellation. From the 21st of June until the 23d of July, the sun passes through this sign, but the stars of which it is composed are then invisible, being overpowered by the superior brightness

of the solar rays. This constellation is easily distinguished by two brilliant stars, denominated *Castor* and *Pollux*, which are within five degrees of each other. *Castor*, a star of the first magnitude, is the northernmost of the two; and *Pollux*, a star of the second magnitude, is situated a little to the south-east of it. *Castor* is found by the telescope to be a double star, the smaller one being invisible to the naked eye; and, from a long series of observations, it is found that the smaller star is revolving around the larger with a slow motion, and that a complete revolution will occupy more than 300 years. About twenty degrees south-west of *Castor* and *Pollux* are three small stars, nearly in a straight line, and about three or four degrees distant from each other. The southernmost of the three lies nearly in a line with *Pollux* and the star *Betelgeuse*, in the constellation of Orion, but somewhat nearer to *Betelgeuse* than to *Pollux*. These stars, in the hieroglyphic figure of Gemini, form the feet of the twins.

Directly south of Gemini is the constellation of *Canis Minor*, or the Lesser Dog. It is situated about midway between Gemini and *Canis Major*, or the Greater Dog, and has *Hydra* on the east, and Orion on the west. It consists of only about fourteen stars visible to the naked eye, the principal of which is *Procyon*, a bright star between the first and second magnitude. It is almost directly south from *Pollux*, and distant from it about twenty-four degrees. The next brightest star in this constellation, which is considerably smaller than *Procyon*, is called *Gomeiza*, and is situated about four degrees north-west of *Procyon*.

South by west of *Canis Minor*, at the distance of nearly thirty degrees, is *Canis Major*, or the Greater Dog. It is south-east from the belt of Orion, and due east from the constellation of *Lepus*, or the Hare, at the distance of ten degrees. *Canis Major* is easily distinguished by the brilliancy of its principal star, *Sirius*, which is apparently the largest and brightest fixed star in the heavens, so that it is generally considered as one of the nearest of these distant orbs, though its distance from the earth is computed at not less than *twenty billions* of miles; and a cannon ball, moving over this immense space at the rate of nineteen miles a minute, would require more than two millions of years before it could reach this distant orb. *Sirius* is south by east of *Betelgeuse* in the left shoulder of Orion, at the distance of twenty-seven degrees, and south-east from the lower star in the belt, at the distance of twenty-three degrees. A line drawn through the three stars which form the belt, toward the south-east, leads the eye directly to *Sirius*, which, at the period and hour we have stated, is about twelve degrees above the south-easterly point of the horizon; a line drawn from *Betelgeuse* south-east toward *Sirius*, and thence to the north-east, meets *Procyon* in *Canis Minor*, and continued nearly due west, it again meets *Betelgeuse*, so that these three stars seem to form a large triangle, which is nearly equilateral. Another triangle is formed by drawing a line eastward from *Betelgeuse* to *Procyon*, as a base, from *Procyon* straight north to *Pollux*, and from thence again south-west to *Betelgeuse*, which forms a right-angled triangle, having the right angle at the star *Procyon*, and the line extending from *Pollux* to *Betelgeuse* forms the hypotenuse.

In order to render these descriptions more definite, I have sketched in Plate I, a small map of this portion of the heavens, in which the princi-

pal stars in the constellations above described are represented. The left-hand side of this map represents the east; the right-hand side the west; the lower part, the south; and the upper part the north, or higher portion of the heavens. When used so as to compare it with the real firmament, the observer is supposed to have his face directed chiefly to the south and the south-eastern parts of the sky. He may then easily distinguish the principal stars laid down in it by the following directions:—A line drawn from *A* to *B*, at the top of the map, passes through the star *Castor* in Gemini, which is near the left-hand side. A line

drawn from *C* to *D*, passes through *Pollux* in the same sign, which is four or five degrees to the south-east of *Castor*; it likewise passes near *Auriga*, a star of the second magnitude, in the constellation of the *Wagoner*, which is represented near the middle of the line. Almost directly north from *Auriga*, at the distance of seventeen degrees, is the star *Capella*, in the same constellation, which is one of the brightest stars in the heavens next to *Sirius*. It is about twenty-eight degrees north-east from the *Pleiades*, but is beyond the northern limits of the map. A line drawn from *E* to *F*, passes through *Aldubaran*, or

## PLATE I.

REPRESENTING A PORTION OF THE SOUTHERN PART OF THE HEAVENS, ABOUT THE MIDDLE OF JANUARY.

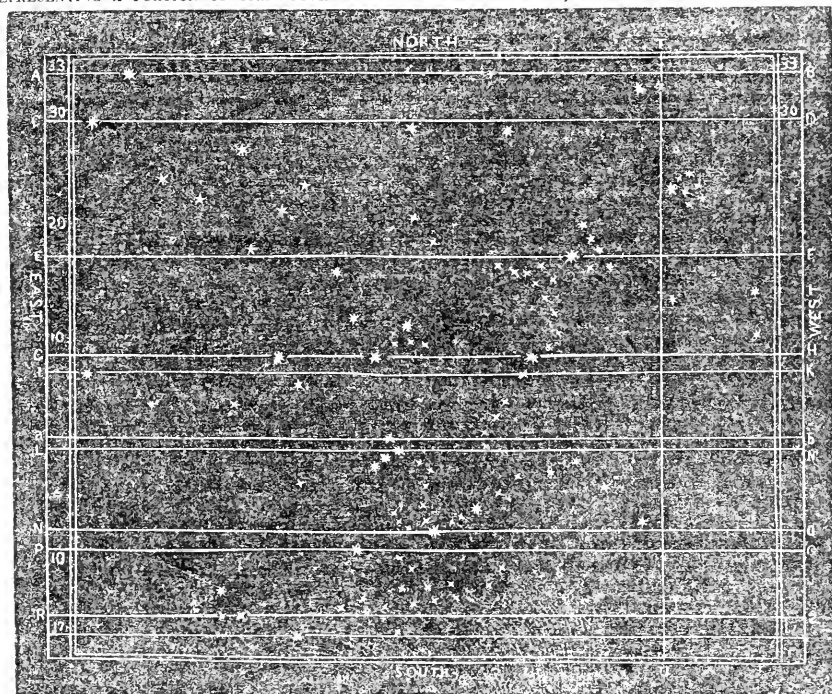

the Bull's Eye, and the Hyades; north-west of which is the Pleiades, or seven stars, near the north-west part of the map. A line drawn from *G* to *H*, passes through the star *Betelgeuse*, in the east shoulder of Orion; the line from *I* to *K*, passes through *Bellatrix*, in the west shoulder, a star of the second magnitude, somewhat less brilliant than *Betelgeuse*, and likewise passes through *Procyon*, in *Canis Minor*, which appears near the left side of the map; and the line from *L* to *M* passes through the middle star of Orion's belt. The line from *N* to *O* passes through *Rigel*, in the left foot of Orion, a star of the first magnitude fifteen degrees south of *Bellatrix*. The line *P* *Q* passes through *Saiph*, a star of the third magnitude, in Orion's right knee, eight and a half degrees east of *Rigel*. The two form the lower end of the parallelogram of Orion. The line *R* *S* passes through the star *Sirius*, in *Canis Major*, which is east by south from *Saiph*, at the distance of fifteen degrees. The small stars to the west, or right hand of *Sirius* form a part of the constellation of *Lepus*, or the Hare. A line drawn from *T* to *U*, from the northern to the southern part of the map, will point out the position of the

stars here represented with respect to the meridian, at the time these observations are supposed to be made. The stars on the right of this line are west of the meridian, and all those to the left are to the east of it.

By attending to the above directions, and comparing the delineations on the map with the heavens, all the stars and constellations noted above may be readily distinguished. The triangles formed by *Betelgeuse*, *Procyon*, and *Sirius*, and by *Pollux*, *Procyon*, and *Betelgeuse*, will likewise be seen on the map, as formerly described, and may be easily traced in the heavens. Although I have fixed on the middle of January, at eight o'clock in the evening, for these observations, yet the same stars may be traced, at different hours, during the months of November, December, January, February, and March. About the middle of November, at midnight, and the middle of December, at ten o'clock, P. M., this portion of the heavens will appear nearly in the same position as here represented. About the middle of February, Orion will be on the meridian about eight in the evening; and in the month of March, at the same hour, considerably to the west of it; but all

the adjacent stars and constellations may be traced at this time in the manner already described. The stars and constellations delineated on this map comprehend a space in the heavens extending in breadth, from north to south, about fifty degrees—namely, from thirty-three degrees of north declination to seventeen degrees south; and in

length, from west to east, about sixty degrees. The equator runs through this portion of the heavens in the direction *a b*, or nearly corresponding to the line *L M*, so that it passes very near to the upper star in the belt of Orion. The degrees of north and south declination\* from the equator are marked on the margin.

## PLATE II.

EXHIBITING A PORTION OF THE CONSTELLATIONS, AS SEEN ABOUT THE FIRST OF SEPTEMBER.

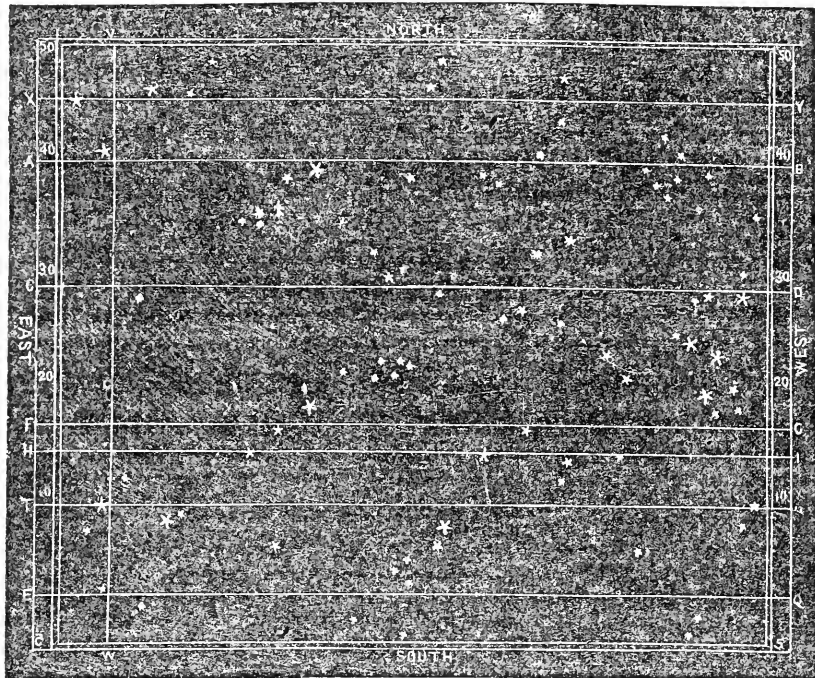

Plate II represents another portion of the heavens as it appears about the beginning of September. It includes some of the larger stars belonging to the constellations *Cygnus*, *Lyra*, *Cerberus*, *Serpentarius*, *Aquila*, *Hercules*, and *Corona Borealis*. At ten o'clock in the evening of the 1st of September, the star Altair, in the constellation of *Aquila*, or the Eagle, will be nearly on the meridian, at an elevation above the horizon of about forty-six degrees. This star, which is between the first and second magnitude, is situated near the east or left-hand side of the map, near the bottom, and has a small star to the south, and another to the north-west of it. A line drawn from *T* to *U* passes through the star Altair, and a line from *V* to *W* passes through the meridian at the hour supposed.

The seven stars which are nearest Altair, toward the south, and west, and north-west, belong to the constellation of *Aquila*. All the stars on the map which are to the right-hand of Altair, are west of the meridian. A line drawn from *X* to *Y*, near the top of the map, passes through *Denib*, a bright star of the second magnitude in the constellation of *Cygnus*, or the Swan, which is the star next the left-hand side, nearly due north from Altair, at the distance of thirty-six degrees; the other four stars adjacent to it belong to the same constellation. A line drawn from *A* to *B* passes through the star *Vega*, or a *Lyra*, a brilliant

star of the first magnitude in the constellation of the *Harp*. The six small stars to the south-east of it likewise belong to this constellation.—The stars on the right, or to the westward of *Vega*, belong chiefly to the constellation of *Hercules*. A line drawn from *C* to *D* passes through the principal star *Corona Borealis*, or the Northern Crown, named *Alphacca*, which is of the third magnitude, and lies near the right-hand side of the map. The stars north and east from it belong to the same constellation. West from *Alphacca* is *Mirac*, at the distance of eleven degrees; and south-west of *Mirac*, at the distance of ten degrees, is *Arcturus*, a bright star of the first magnitude, which is then about eighteen degrees above the western horizon. Both these stars are in the constellation of *Bootes*, but they are not within the limits of the map. A line drawn from *F* to *G* passes through *Ras Algethi*, a star of the second magnitude, and the principal star in the constellation of *Hercules*, which is twenty-five degrees south-east of *Corona Borealis*. A line from *H* to *I* passes through *Ras Alhaque*, a star of the second magnitude in the head of *Serpentarius*. This star is five degrees east by south

\* The declination of a heavenly body is its distance north or south from the equinoctial, or equator, and corresponds to latitude on the terrestrial globe, which is the distance of a place from the equator. The latitude of a heavenly body is its distance north or south of the ecliptic, or apparent path of the sun, which forms an angle of  $32\frac{1}{2}$  degrees with the equinoctial.



of Ras Algethi. Most of the other stars to the south and east in the map belong to Serpentarius. Various other remarkable stars may be seen at this time beside those noted in the map, particularly the square of *Pegasus*, or the Flying Horse. About fifty-three degrees nearly east from Altair is *Markab*, a star of the second magnitude; sixteen and a half degrees east of *Markab* is *Algenib*, another star of the second magnitude; fourteen degrees north of *Algenib* is *Alpheratz*, and fourteen degrees west of *Alpheratz* is *Scheat*, both of them stars of the second magnitude. These four stars, of nearly equal magnitudes, form the *Square of Pegasus*, and appear nearly half-way between the eastern horizon and the meridian.

All the stars alluded to above may likewise be seen during the months of July and August, when they will appear in a more easterly position than at the time stated above; and in the month of October, at eight o'clock, and in November, at six o'clock in the evening, they will be seen nearly in the positions which have been now represented.

Plate III represents a view of some of the principal stars around the pole, extending from the polar point, in every direction, about forty-five degrees. In using this map, the observer is supposed to be looking toward the north, in which case, the left hand side of the map is toward the west, and the right side toward the east. The large star near the center of the map is the Pole-star, which forms the tip of the tail of *Ursa Minor* the square of which, and the two other stars in the tail, will be seen ascending from it toward the right hand, when the map is so placed that the 1st of April is at the top. There is only one star of the first magnitude within the limits of this map—namely *Capella*, the principal star in the constellation of *Auriga*, opposite that part of the map where the month of December is marked. A line drawn from *C* to *D* passes through this star, which is adjacent to the extremity of the map. There are eleven stars of the second magnitude; five in the square and tail of *Ursa Major*, or the Great Bear—namely the two pointers, *Dubhe* and *Merak*, *Phad*, *Alioth*, and *Benetnasch*. The others are *Menkalina*, *Etanin*, *Rastaban*, *Algenib*, *Delta*, *Cygni*, and the Pole-star. A line drawn from *A* to *B* passes through *Dubhe* and *Merak*, and the Pole-star at the center of the map; and on the other side of the Pole-star it passes through a part of the constellation of *Cassiopeia*—the Pole-star being nearly equidistant between that constellation and the pointers. A line drawn from *E* to *F* passes through *Menkalina*, in the constellation of *Auriga*, about eight degrees from *Capella*. A line drawn from *G* to *H* passes through *Delta Cygni*, in the Swan, which is placed at the extremity of the map. A line from *I* to *K* passes through *Algenib*, the principal star in the constellation of *Persens*. A line from *L* to *M* passes through *Etanin*, near the right-hand side of the map, a star of the second magnitude in the constellation of *Draco*, near to which, at the distance of four or five degrees is *Rastaban*, likewise a star of the second magnitude in the same constellation. With two other stars they form a kind of irregular square or trapezium, and, with another small star, they form a figure resembling an italic *V*. When the star *Etanin* comes to the meridian of London, it is exactly in the zenith of that place, which has rendered it of peculiar utility in certain nice astronomical observations. It is celebrated in modern times as being the star which Dr. Bradley selected to determine, if possible, the *Annual Parallax*; and from his observations of which he deduced the important discovery of the *Aberration of Light*.

Let us now suppose that we are to contemplate the northern part of the heavens about the beginning of April, at ten o'clock in the evening. Turning our faces toward the pole-star, or directly north, and holding that part of the map uppermost which is opposite to the beginning of April, those stars which are marked on the upper part of the map will appear not far from the zenith, or nearly overhead; those toward the lower part will appear at a low elevation, not far from the horizon; those on the right will appear in the east, and those on the left in the west, at different elevations, as here represented. The two pointers in the Great Bear, which are directly opposite to the 1st of April, will be seen nearly in the zenith, and to point downward to the pole-star; and at nearly an equal distance below the pole-star, they direct the eye to the constellation *Cassiopeia*, which is conceived to have a certain resemblance to a chair, and which appears only a small distance above the northern horizon. To the west or left-hand side of *Cassiopeia* is the constellation *Persens*, of which *Algenib* is the principal star, and which is likewise at a low elevation. To the right, or east side of *Cassiopeia* is *Cepheus*—four stars of which, two of the third, and two of the fourth magnitude, form a kind of square, or rhombus. The stars farther to the east, and in a more elevated position, belong chiefly to the constellation of *Draco*, or the Dragon. The star *Etanin*, in this constellation, appears nearly due east of the pole-star, at the distance of forty degrees. The stars on the western side of the map, or on the left-hand nearly opposite to *Etanin*, belong to the constellation of *Auriga*; and those on the upper part are chiefly some of the prominent stars connected with the Great Bear. The bright star *Capella* appears nearly west by south from the pole-star, at a pretty high elevation, with *Menkalina* a little above it, and to the eastward.

Beside the stars marked on this map, there may be seen, at the same time, several brilliant stars of the first magnitude. Turning the eye east by south, the bright star *Arcturus*, in the constellation *Bootes*, is seen about half-way between the horizon and the zenith. Looking to the north-east, the brilliant star *Vega*, or *Lyra*, appears elevated twenty degrees above the horizon, in a direction nearly opposite to *Capella*, in the west. Farther to the north, but not quite so elevated as *Lyra*, is *Denib*, in the constellation of the Swan. Turning our eye to the west, *Castor* and *Pollux* will be seen about midway between the western horizon and zenith; and farther down, near the horizon, almost due west, are *Betelgeuse* and *Belatrix*, the two stars in the shoulders of *Orion*, *Betelgeuse* appearing the more elevated of the two, the other portions *Orion* having descended below the horizon. To the south-west, midway between *Pollux* and the horizon, is *Procyon*, a star of the first magnitude in the Lesser Dog.

Suppose, now, we were to observe the same quarter of the heavens, at the same hour, about the beginning of October. In this case we have only to reverse the map so that the first of October may be uppermost. At this season, *Cassiopeia* will appear near the zenith and the two pointers of *Ursa Major* will be seen at the opposite side of the pole, at no great elevation above the horizon. *Capella* will appear toward the east, on the right, at a considerable altitude, and the five stars in the head of *Draco* considerably to the west, while *Algenib*, and the other stars in *Persens*, will be seen in a high elevation, to the east of *Cassiopeia*. At this time, likewise, by turning our eyes toward the east and the south, *Aldebaran*, or the Bull's-eye, in the constellation



Taurus, will be seen elevated about twelve degrees above the eastern horizon, about sixteen degrees above which are the Pleiades, or seven stars. The star Altair will appear near the south-west, halfway between that point and the meridian, and *Pomalhaut*, in the Southern Fish, will be seen nearly on the meridian, only five or six degrees above the south point of the horizon.

In like manner, were we wishing to observe the position of the circumpolar stars at any other hour, at this period, than ten o'clock, P. M., suppose at eight in the evening, we have only to turn the line which marks the beginning of September uppermost instead of October, and the position at that hour will be seen; and if we choose to make our observations at six in the evening, we turn the first of August to the top, allowing two hours, at an average, for every month. If we would inspect their position at twelve midnight, the first of November must be turned round to the top, and so

on for any other hour. If we would make our observations in the beginning of January at ten, P. M., that point must be turned to the top, and then the two pointers will be seen on the right, straight east of the pole-star, and the other five stars hanging down from them, Cassiopeia nearly straight west, and Capella not far from the zenith. These circumpolar stars may therefore be seen at every season of the year, and their relative positions determined beforehand, by simply turning round the map to the month, or day of the month, required, so that that point may be at the top; and although the months are arranged so as to correspond with ten o'clock, P. M., yet the positions may be represented for any other hour, according to the directions given above.

The following remarks may be stated in reference to the stars depicted on this map:—1. All these stars never set in our latitude, but appear to move round above the horizon in circles of which the

## PLATE III

## THE NORTH CIRCUMPOLAR STARS.

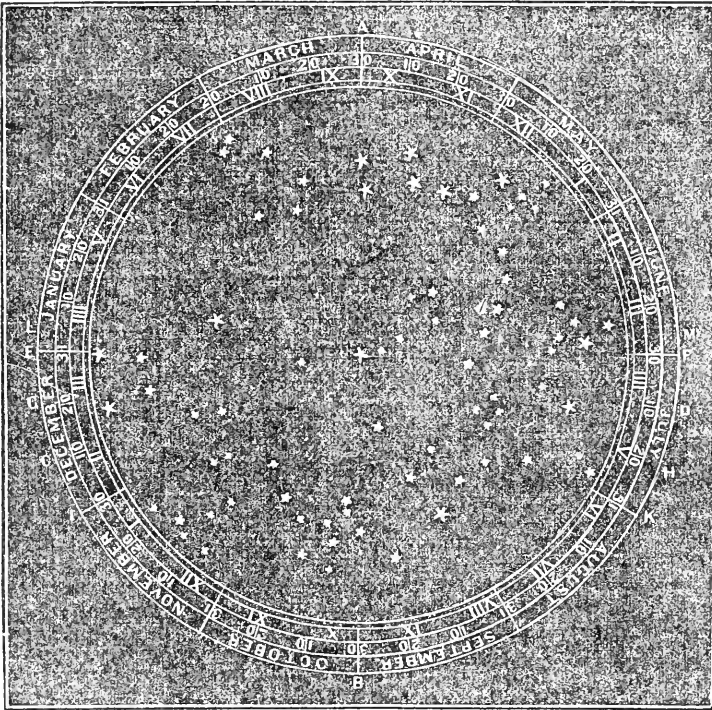

pole is the center. As the observer is supposed to be in fifty-two degrees N. latitude, all the stars within  $52^{\circ}$  of the pole never descend below the horizon. In one part of their diurnal course they appear above the pole, and some of them near the zenith, and in the opposite point they appear below the polar point, and sometimes near the northern horizon. 2. In the higher part of their course they appear to move from east to west, and in the lower part from west to east. Those nearest the pole describe small circles around the polar point, and those at greater distances describe larger circles; but their periods of apparent revolution are exactly the same—namely, twenty-three hours, fifty-six minutes, and four seconds. 3. The stars represented in

this map are only those which are most prominent and obvious to the naked eye, in order to prevent confusion, and that the untutored observer may not be distracted with too many objects at one view. They chiefly consist of stars of the second, third, and fourth magnitudes. 4. In order that the observer may be able readily to estimate the apparent distances of the stars from each other and from the horizon, it may be proper to keep in mind that the distance between the two pointers is exactly five degrees, and between Dubhe (the nearest to the pole) and the pole-star, twenty-nine degrees. By applying these measures by the eye to other stars, their apparent distances may be very nearly estimated. 5. Although I have stated, in general terms, that the pointers come to the

southern meridian, or are nearly in the zenith, at ten, P. M., about the beginning of April, yet it is not before the seventh of this month that they are accurately in this position at ten in the evening; but the difference is not much perceptible by the eye during the course of a week or two, and therefore can lead to no great mistake. 6. If the circle containing the stars were cut out, and surrounded with the circle of months and days, and made to revolve within the circle of hours, it might be made to serve the purpose of an astronomical clock for pointing out the hours of the night, and likewise for showing the positions of the circumpolar stars for any hour of the day or night. 7. The delineations of the apparent distances of the stars on this map are on a scale of only one-half the size of that on which the two preceding maps were constructed.

The three preceding views of certain portions

of the heavens, partly delineated from actual observation, are intended to convey to general observers a natural representation of those quarters of the firmament to which they refer, so that by a little further attention and observation, and an inspection of a celestial atlas, they may acquire a general view of the principal stars and constellations visible in our hemisphere; for on most celestial planispheres and globes there is such a group of eyes, noses, legs, tails, claws, and wings connected with the mythological figures of the constellations, no traces of which can be seen in the heavens, that the learner is sometimes confounded, and can scarcely trace any resemblance between what is depicted on such globes and planispheres and the real aspect of the firmament, the stars appearing, in many instances, as accidental spots, buried, as it were, amid the group of hieroglyphics with which they are connected.

## CHAPTER II.

### ON THE ARRANGEMENT OF THE STARS INTO CONSTELLATIONS, WITH SKETCHES OF THEIR MYTHOLOGICAL HISTORY.

In order to distinguish the stars from one another, the ancients divided the heavens into different portions or spaces, called *constellations*, or groups of stars. They supposed each group to occupy a space which a lion, a bear, a man, a harp, or other object would fill, if it were there delineated; and hence the different constellations were depicted as if they had borne a resemblance to dragons, dogs, rams, altars, ships, and similar objects, whether imaginary or real. The invention of the constellations, particularly those of the Zodiac, is generally attributed to the Chaldeans or the Egyptians; but most probably the merit, such as it is, is due to the former, although the Egyptians appear, at a very early period, to have derived the knowledge of astronomy from the inhabitants of Chaldea, and imparted it to the ancient Greeks and other nations. The first series of constellations which were formed appear to have been those of the Zodiac. Finding that the year consisted neither of twelve nor of thirteen lunations, in order to know the precise bounds of the annual course of the sun, they were under the necessity of carefully examining what stars were successively obscured in the evening by the motion of that globe, and what stars, after emerging from its rays, showed themselves again before the dawn of day.

Macrobius, an ancient Roman author, and Sextus Empiricus, a Greek writer, have handed down to us the ingenious method which the first astronomers used to determine exactly the course which the sun describes in the heavens, and to divide the year into equal portions, of which the following is a condensed description:

They every day saw the sun and the whole heavens turning round from east to west. In the meantime they observed that the sun, by a motion peculiar to it, receded, from day to day, from certain stars, and took its place under others, always advancing toward the east. As they found that twelve revolutions of the moon approximated to one revolution of the sun, but that a certain sensible difference existed, they wished that they might have twelve divisions of the year, which

might be *exactly* equivalent to the year itself. For this purpose they took two brass open vessels, the one pierced at the bottom, and the other without any orifice below. Having stopped the hole of the first, they filled it with water, and placed it so that the water might run out into the other vessel the moment the cock should be opened. This done, they observed in that part of the heavens where the sun has its annual course, the rising of a star, remarkable either for its magnitude or its brightness, and at the critical instant it appeared on the horizon they began to let the water flow out of the upper vessel into the other, during the rest of the night and the whole following day, until the very moment when the same star began to appear anew on the horizon. The instant it was again seen they took away the under vessel, and threw the water that remained in the upper on the ground. The observers were thus sure of having one revolution of the whole heaven, between the first rising of the star and its return. The water which had flowed during that time now afforded them the means of measuring the duration of one whole revolution of the starry firmament, and of dividing that duration into several equal portions. They then divided the water of the under vessel into twelve parts, *perfectly equal*, and prepared two other small vessels capable of containing exactly one of these portions, and no more. They again poured into the great copper vessel the twelve parts of water all at once, keeping the vessels shut. They then placed under the cock, still shut, one of the two small vessels, and another near it to succeed the first as soon as it should be full. All these preparations being ready, the next night they observed that part of the heavens toward which they had remarked the sun took his course, and waited for the rising of the constellation which has since been called *Aries*. The instant Aries appeared, and they saw the first star of it ascending, they let the water run into the little measure. As soon as it was full they removed it, and threw the water out. In the meantime they put the other empty measure

under the fall. They observed accurately all the stars that rose during all the periods which the measure took in filling, and that part of the heavens was terminated in their observations by the star which appeared last on the horizon the moment the measure was just full. In like manner they proceeded with the other vessel alternately, until the two small vessels were three times filled, which marked out six divisions, or one-half of the course of the sun in the heavens. They were then forced to defer the observation and measurement of the other half of the firmament until the opposite season of the year, when they proceeded as before.

Having in this manner determined the twelve divisions of the heavens, and marked the clusters of stars peculiar to each, they proceeded to give them names, and in general termed them the stations or *houses* of the sun, three of which were assigned to each season. The particular names given to each of the twelve constellations of the Zodiac are generally supposed to refer to certain circumstances peculiar to the different months. As the Chaldean observers seem to have been of opinion that there were, during the spring, no production more useful than lambs, calves, and rams, they gave the constellations through which the sun passes during that season the names of the three animals by which they were most enriched. The first was named *Aries*, or the Ram; the second *Taurus*, or the Bull; and the third *Gemini*, or the Twins,—that is, the two goats, which commonly bring forth two young at a time. The Greeks afterward represented them by Castor and Pollux, two twin brothers, sons of Jupiter, by Leda, the wife of Tyndarus, and as such they are represented on our globes. Having remarked that there was a point to which the sun approached when passing these signs, but which it never went beyond, and that it afterward receded from that point for six months together, this retreat of the sun backward led them to distinguish it by the name of an animal which walks backward, and hence it was denominated *Cancer*, or the Crab. As the heats in the next month (July) are most intense, they compared them to the raging and fierceness of a lion, and hence they called the sign *Leo*, that is, the Lion. As in the next month harvest commences, and as young girls were generally set to *glean* in the fields, they denominated the sign corresponding to this month *Virgo*, or the Virgin, which is represented by the figure of a young woman holding an ear of corn.

The perfect equality of days and nights which happens when the sun quits the sign of *Virgo*, caused astronomers to give the next sign the name of *Libra*, that is, the Balance, poised so as to represent equal day and night. The frequent diseases which are produced in consequence of the sun retiring to the south procured the next sign the name of *Scorpio*, or the Scorpion, because it is mischievous, and drags after it a sting and venom. When harvest is over, and the fields cleared of the crops, then is the season for hunting, and therefore the sign in which the sun enters at that time has obtained the name of *Sagittarius*, that is, the Archer, or Huntsman. The next constellation, *Capricorn*, had its origin from the wild goat, whose nature being to seek its food from the bottom to the top of mountains, was considered emblematical of the ascent of the sun from the lowest point of its course, in the beginning of this sign, to its highest pitch or summit in the summer solstice, when it enters the sign *Cancer*. The next sign is called *Aquarius*, or the

Water-bearer, emblematical of the rains which generally fall at this season of the year; and the last sign is named *Pisces*, or the Fishes, which name seems to have been given because at the time when the sun enters it, fishes are then considered as fattest and most in season for use.

Such were the names and symbols which the ancients appropriated to that great circle or zone of the heavens through which the sun, moon, and planets appeared to move. As the names of ten of these signs or constellations are borrowed from several animals, astronomers gave the annual zone which they compose, the name of the *Zodiac*, that is, the circle of animals, from the Greek word *zoon*, an animal. By this division of the heavens, mankind acquired a new method of measuring time and of regulating all their labors. From the knowledge of the Zodiac they obtained an exact knowledge of the year and of its several subdivisions, and the periods when sowing ought to commence, and when the fruits of harvest might be expected to arrive at maturity. When, after the setting of the sun, they saw the stars of the sign *Aries* ascend the opposite horizon, and distant from the sun by one-half of the sphere of the heavens, they then knew that the sun was under the sign *Libra*, which, being the seventh of the celestial signs, was distant from the first by one-half of the whole Zodiac. When, at the approach of day, they saw, in the middle of the firmament, or on their meridian, at an equal distance from east and west, the principal star of the sign *Leo*, they understood that the sun, then about to rise, was at the distance of *three signs* from *Leo*, and removed toward the east one-fourth part of its circle. Thus, without seeing the stars, which were obscured and overpowered by the sun's rays as he passed through them, they could say, with a perfect assurance, "the sun is now in *Scorpio*, and in two months hence the shortest day will arrive." On the sight of a single constellation, placed either in the eastern, western, or middle part of the heavens, they could immediately tell in what sign the sun was, how far the year was advanced, and what kinds of labor were requisite to be performed. It is therefore to astronomy we are originally indebted for our knowledge of the length of the year, and the commencement of its different seasons.

The ancients next proceeded to arrange into constellations the other groups of stars which were situated to the north and south of the Zodiac. In forming this arrangement they proceeded on principles similar to those by which they had delineated the signs of the Zodiac. They conceived the different groups as if they bore a certain resemblance to birds, beasts, serpents, or to certain imaginary beings, and gave them names corresponding to such conceptions. This they seem to have done for the sake of assisting the memory and imagination in forming a general idea of the forms and the relative positions of the several clusters of stars, and to enable the observer more readily to distinguish and to point out any particular star; but it would be too tedious, and would convey little profitable instruction, to inquire into the reasons of the emblematical figures they adopted, or to attempt a detailed view of their mythological history.

The following table contains a list of all the constellations, ancient and modern, with the number of stars in each, as stated in the *Historia Cœlestis of Flamsteed*, formerly Royal Professor of Astronomy at Greenwich. The first column contains the *name* of the constellation, the second column, the number of stars it contains, and the

third column, the principal stars and their magnitudes. The number 1, expresses stars of the first magnitude; 2, those of the second magnitude, &c.

## NORTHERN CONSTELLATIONS.

Name.	No. of Stars.	Principa. Stars.
Ursa Minor—the Little Bear .....	24 .....	Pole star, 2.
Ursa Major—the Great Bear .....	87 .....	Dubhe, 1; Alioth, 2
Draco—the Dragon .....	80 .....	Rastaben, 2
Cepheus [East of Draco] .....	35 .....	Alkæranin, 3.
Bootes—the Herdsman .....	54 .....	Arcturus, 1; Mirac, 3
Corona Borealis—the Northern Crown [East of } Bootes] .....	21 .....	Alphecca, 2.
Hercules, with Cerberus .....	113 .....	Ras Algethei, 2.
Lyra—the Harp .....	21 .....	Vega, or Lyra, 1.
Cygnus—the Swan .....	81 .....	Deneb, 2.
Cassiopeia—Lady in her chair .....	55 .....	Schedir, 3.
Perseus, and Head of Medusa .....	59 .....	Algenib, 2; Algol, 2
Auriga—the Wagoner .....	66 .....	Capella, Alajoth, 1.
Serpentarius—Serpent Bearer .....	74 .....	Ras Alhague, 2.
Serpens—the Serpent .....	64 .....	
Sagitta—the Arrow [N. of Aquila] .....	18 .....	
Aquila and Antinous—the Eagle, &c. ....	71 .....	Altair, 1 or 2.
Delphinus—the Dolphin .....	18 .....	
Equuleus—the Horse's Head .....	10 .....	
Pegasus—the Flying Horse .....	89 .....	Markab, 2; Scheat, 2.
Andromeda .....	66 .....	Alamak, 2; Mirack, 3
Triangulum—the Triangle .....	16 .....	
Camelopardalis—Camelopard .....	58 .....	
Leo Minor—the Little Lion .....	53 .....	
Coma Berenices—Berenices' Hair [North of } Virgo] .....	43 .....	
Vulpecula et Anser—the Fox and Goose { [South of Cygnus] .....	35 .....	
Lacerto—the Lizard [East of Cygnus] .....	16 .....	
Scutum Sobieski [North of Sagittarius] .....	8 .....	
Canis Venatici—the Greyhounds .....	25 .....	
Lynx .....	44 .....	
Cerberus .....	4 .....	
Mons Menelaus [S. E. of Bootes] .....	11 .....	
Taurus Poniatowski—the Bull of Poniatowski } [W. of Aquila] .....	7 .....	
Musca—the Fly [N. of Aries] .....	6 .....	
Tarandus—Reindeer [at N. Pole] .....	12 .....	
Total number of stars in the Northern } Constellations .....	1444	

## SOUTHERN CONSTELLATIONS.

*Those Constellations marked thus † never rise in N. latitude 52 degrees.*

Name.	No. of Stars.	Principal Stars.
Cetus—the Whale .....	97 .....	Menkar, 2; Mira, 2.
Orion .....	78 .....	Betelgeuse, 7; Rigel, 1
Eridanus—the River Po .....	84 .....	Achernar, 1.
Lepus—the Hare [S. of Orion] .....	19 .....	
Canis Major—the Great Dog .....	31 .....	Sirius, 1.
Canis Minor [N. of Monoceros] .....	14 .....	Procyon, 1.
Argo Navis—the Argo .....	64 .....	Canopus, 1; Naos, 2
Hydra—the Serpent .....	60 .....	Cor Hydrae, 1
Crater—the Cup [S. of Virgo] .....	31 .....	Algorab, 3.
Corvus—the Crow [S. of Virgo] .....	9 .....	Alkes, 3.
Centaurus—the Centaur .....	35 .....	
Lupus—the Wolf .....	24 .....	
Ara†—the altar .....	9 .....	
Corona Australis—Southern Crown .....	12 .....	
Piscis Australis—[S. of Aquarius] .....	24 .....	Fomalhaut, 1.
Columbo Noachi—Noah's Dove .....	10 .....	
Robor Caroli† [E. of Argo Navis] .....	12 .....	
Grus†—the Crane .....	13 .....	
Phoenix† .....	13 .....	
Indus†—the Indian .....	12 .....	
Pavo†—the Peacock .....	14 .....	
Apus†—the Bird of Paradise .....	11 .....	

Name.	No. of Stars.	Principal Stars
Apis Musca† Australis .....	4	
Triangulum Australis† [South Triangle] .....	5	
Piscis Volant†—the Flying Fish .....	8	
Chameleont† [near the S. Pole] .....	10	
Dora lo†—the Sword Fish .....	6	
Toucou†—the American Goose .....	9	
Hydrus†—the Water Snake .....	10	
Sextans—the Sextant [S. of Leo] .....	41	
Monoceros—the Unicorn .....	31	
CRUX—the Cross† .....	6	
The Sculptor's Apparatus .....	12	
Circinus †—The Compasses .....	7	
Brabantium Sceptrum [S. W. of Orion] ...	6	
Equuleus Pictorius .....	8	
Fornax Chemica .....	14	
Horologium†—the Clock .....	12	
Mons Mens†—the Table Mountain .....	30	
Machina Pneumatica—the Air Pump .....	24	
Norma, or Euclid's Square .....	12	
Octans Hadlianus†—Hadley's Octant .....	43	
Pyxis Nautica—Mariner's Compass .....	8	
Reticula Rhomboidalis† .....	10	
Telescopium†—the Telescope .....	9	
Sculptorio†—the Engraver's Tools .....	16	
Microscopium—the Microscope .....	10	

Total number of stars in the Southern }  
 Constellations ..... } 1027

ZODIACAL CONSTELLATIONS.

Name.	No. of Stars.	Principal Stars.
Aries—the Ram .....	66	<i>α</i> Arietis, 2.
Taurus—the Bull .....	141	Aldebaran, 1; Pleiades.
Gemini—the Twins .....	85	Castor, 1; Pollux, 1.
Cancer—the Crab .....	83	Acubens, 3.
Leo—the Lion .....	95	Regulus, 1; Denebola, 2.
Virgo—the Virgin .....	110	Spica Virginis, 1.
Libra—the Balance .....	51	Zabeneschamale, 2.
Scorpio—the Scorpion .....	44	Antares, 1
Sagittarius—the Archer .....	69	
Capricornus—the Goat .....	51	
Aquarius—the Water Bearer .....	108	Scheat, 3.
Pisces—the Fishes .....	113	

Total number of stars in the Zodiac ..... 1016  
 Total number of stars in all the Constellations ..... 3487

Thus all the visible stars in the firmament have been arranged into ninety-four constellations, of which forty-eight were formed by the ancients, and the rest within the last two or three hundred years. Of the stars above enumerated, there are about 17 of the first magnitude, 76 of the second, 223 of the third, and the remainder of the fourth, fifth, and sixth magnitudes. The different classes of magnitudes are intended to express their apparent brightness. The brightest stars are said to be of the first magnitude; those which appear next in brightness, or inferior to the first, are classed in the second magnitude; and so on down to the sixth magnitude, which comprises the smallest stars visible to the naked eye in the clearest night; though there are but few eyes that can distinguish those which belong to the sixth magnitude. All the stars beyond these limits come under the general denomination of *Telescopical*; and with the most powerful telescopes, stars may be perceived of all classes, from the sixth to the sixteenth order of magnitudes. Every increase in the power of these instruments brings into view innumerable multitudes of those orbs which were before invisible, so that no definite limits can be assigned to the apparent bright-

ness or magnitude of the stars. This classification into magnitudes, however, as it is entirely arbitrary, so it is extremely indefinite, and can convey no very accurate ideas even of their *apparent* brightness or intensity of light. This consideration has led some eminent astronomers to endeavor to estimate the apparent brightness of each star by experiments made with the photometer. From various experimental comparisons of this kind, the late Sir Wm. Herschel deduced the following conclusions:

Light of a star of the average	Magnitude.	
	1st	- == 100
	2d	- == 25
	3d	- == 12
	4th	- == 6
	5th	- == 2
	6th	- == 1

So that the light of a star of the second magnitude is one-fourth of that of a star of the first magnitude; the light of one of the third, one-eighth; of the fourth, one-sixteenth; of the fifth, one-fiftieth; and of the sixth, only one-hundredth part. Sir John Herschel informs us that, from his own experiments, he has found that the light of

*Sirius*, the brightest of all the fixed stars, is about 324 times that of an average star of the sixth magnitude.

It may be proper to observe that the stars specified in the statements inserted above are not all visible to the naked eye, nearly two-thirds of them being perceptible only by the telescope; but they are those stars whose latitudes and longitudes, and whose right ascensions and declinations, have been accurately determined. They form only a *very small proportion* of those which are found to exist in the most distant regions of the firmament; for by powerful telescopes there have been explored, in a single speck of the heavens, a number which far exceeds that of all the visible stars in the sky; and catalogues have been formed in modern times which comprise from fifty to a hundred thousand of these luminaries.

The first astronomer, so far as we know, who attempted to take a catalogue of the stars, was *Hipparchus* of Rhodes, who flourished about 120 years before Christ. Having observed a new star, which he had never seen before, he began to doubt whether there might not be changes occasionally taking place among these luminaries, and therefore commenced making a catalogue of them, noting down the position and magnitude of each star, with the view that, if any new stars should again appear, or any of those observed by him should increase or diminish in magnitude, or totally disappear, such changes might be known to those who should live in future ages. This catalogue, which was handed down to us by Ptolemy, an ancient Egyptian astronomer, has been of special use to modern astronomers, both in determining the rate of the precession of the equinoxes, and in proving that certain stars which then existed are no longer to be seen in the heavens; thus indicating that changes and revolutions are taking place among the distant bodies of the universe. The catalogue of Hipparchus contained a description of the places of 1026 stars. The Arabians are the next whom history represents as having attempted to form a descriptive catalogue of the stars. This was effected by *Ulug Beigh*, the grandson of Tamerlane, from his own observations made at Samarcand, whose catalogue contains 1022 stars. Tycho Brahe, the celebrated Danish astronomer, who lived in the sixteenth century, by means of the large and accurate instruments he invented, formed a catalogue of 777 stars, which are considered as superior in correctness to those of Hipparchus and Ulug Beigh. He was prompted to this laborious undertaking by the sudden appearance of a new star in Cassiopeia in the year 1572, which shone with the brilliancy of Venus, and was visible even at noonday. *Bayer* soon after published a catalogue of 1169 stars, in which he introduced the practice of distinguishing the stars by the letters of the Greek alphabet. All the catalogues now mentioned were formed before the telescope was invented, and contained nearly all the stars which could be perceived by the unassisted eye. Soon after the invention of the telescope, in the beginning of the seventeenth century, the celebrated *Hévelius* composed a catalogue of 1888 stars, of which 1553 were observed by himself, and their places computed for the year 1669. But some of our modern observers of the heavens have published catalogues which contain the positions of many thousands of stars beside multitudes of nebulae, of various descriptions, double, triple, and quadruple stars, and various other celestial phenomena.

The division of the heavens into constellations,

and the names and figures by which they are distinguished, seem to have been of a very ancient date. Job, who is supposed to have lived in a period prior to that of Moses, refers to some of them by the same names which they still bear. "Canst thou bind the sweet influences of *Pleïades*"—or the seven stars,—“or loose the bands of Orion?” that is, the *belt* of Orion, which consists of three equidistant stars in a straight line.—“Canst thou bring forth Mazzaroth in his season? or canst thou guide Arcturus with his sons?” Arcturus is a bright star of the first magnitude in the constellation of Bootes, and is here put for the constellation itself. The expression “his sons” is supposed to refer to *Asterion* and *Chiara*, the two Greyhounds, with which he seems to be pursuing the Great Bear around the North pole, in the diurnal revolution of the heavens. *Mazzaroth* is generally supposed to refer to the twelve signs of the zodiac, which, by their appointed revolutions, produce the succession of day and night, and the seasons of the year. In another part of this book, Job, when filled with profound reverence of the majesty of God, declares that He alone “spreadeth out the heavens, and maketh Arcturus, Orion, and the Chambers of the South.” The prophet Amos, who lived 890 years before the Christian era, alludes to the same objects in the fifth chapter of his prophesy.—“Ye who turn judgment to wormwood, and leave off righteousness in the earth, seek him who maketh the seven stars and Orion, who turneth the shadow of death into morning, and maketh the day dark with night; that calleth for the waters of the sea, and poureth them out upon the face of the earth; the Lord of Hosts is his name.”

The names of the constellations, and the hieroglyphic figures by which they are represented, appear, however, to have had their origin in superstitions and idolatrous notions. The Egyptians, it is well known, worshiped the host of heaven under the figures of most of the animals which represent the celestial constellations, particularly the signs of the Zodiac. They imagined the sun, which they called *Osiris*, to be a proper representative of the Spirit of Nature, or the Supreme Being, who, like the sun, appears everywhere present, exercising his influence over the universe. The moon, as she receives her light from the sun, was looked upon as a female divinity, and called *Isis*,—which goddess was made to signify universal nature considered as passive, and susceptible of various impressions, forms, and qualities.—They found, or imagined they found, in various animals, some properties or qualities corresponding to the motions, appearances, or influences of the sun, moon, and stars. This induced them not only to use those animals in their hieroglyphic representations of their deities, but also to pay them honors. Thus, by the *Ram*, a prolific animal, they represented the genial, fertilizing influence of the sun in spring; and by the hot and furious *Lion*, his violent scorching heat in the summer; and the Bull was an emblem of the various powers of the sun in forwarding the business of agriculture, in which this animal was of particular service. As the overflowing of the Nile is particularly beneficial to the land of Egypt, and as that river was observed to begin to swell at the rising of *Sirius*, or the Dog Star, so they had a special veneration for that orb, as if its divine influence had contributed to that fertility which was produced by the inundation of the Nile. That the Egyptians worshiped all the animals depicted on the Zodiac, and those which represent several of the other constellations, is proved by the testimony of several an

cient authors, particularly Herodotus, who says that "in Egypt all sorts of beasts, whether wild or tame, were accounted as sacred, and received divine honors." And it is not improbable that this worship of the host of heaven, through the hieroglyphics of various animals, was a general practice during the abode of the Children of Israel in that country, and that the following admonition of Moses has a reference to this circumstance:—"Take heed lest ye corrupt yourselves and make you a graven image, the similitude of any figure, the likeness of any male or female, the likeness of any beast that is on the earth, the likeness of any fowl that flieth in the air, the likeness of anything that creepeth upon the ground, the likeness of any fish that is in the waters beneath the earth; and lest thou lift up thine eyes to heaven, and when thou seest the sun, and the moon, and the stars, even all the host of heaven, shouldst be driven to worship them and serve them, which the Lord thy God hath divided unto all nations under the whole heaven. But the Lord thy God hath taken you, and brought you forth out of the iron furnace, and brought you forth out of the iron furnace, even out of Egypt." The reference here made to their being brought out of Egypt seems evidently intended to put the Israelites in mind of their deliverance from the idolatrous practices of the inhabitants of that country, as well as from the slavery to which they had been subjected, and consequently implies that the Egyptians indulged in the superstitious worship to which we have alluded.

As it is the practice of astronomers to denote the relative apparent magnitudes of stars in each constellation by the letters of the Greek alphabet, the whole of this alphabet is here inserted, that the unlearned reader may be enabled to distinguish the different characters, and the order in which they follow each other.

The first letter of the Greek Alphabet  $\alpha$ , denotes the largest or brightest star in each constellation. Thus,  $\alpha$  Lyrae is the brightest star in the constellation of Lyra, or the Lyre;  $\beta$  Lyrae, the star next in brightness to alpha; and so on through

out all the letters of the Greek alphabet. When the number of stars to be distinguished in any constellation is greater than the number of letters in the Greek alphabet, astronomers have recourse to the letters of the English alphabet, and distinguish the remaining stars, according to their apparent brilliancy, by the letters a, b, c, d, &c.; and if more stars still remain to be distinguished, they resort to numerals,—thus, a<sup>2</sup>, d<sup>4</sup>, &c. From this mode of distinguishing the apparent magnitude of the stars, the reader will easily perceive that those stars which are distinguished by the first letters of the Greek alphabet are the largest in any particular constellation, while those which are marked with letters toward the close of the alphabet are among the smaller stars.

GREEK ALPHABET.

Greek Characters.	Names.	Greek Capitals.	Roman Characters.
$\alpha$	Alpha	A	a
$\beta$	Beta	B	b
$\gamma$	Gamma	$\Gamma$	g
$\delta$	Delta	$\Delta$	d
$\epsilon$	Epsilon	E	e, short
$\zeta$	Zeta	Z	z
$\eta$	Eta	H	e, long
$\theta$	Theta	$\Theta$	th
$\iota$	Iota	I	i
$\kappa$	Kappa	K	k
$\lambda$	Lambda	$\Lambda$	l
$\mu$	Ma	M	m
$\nu$	Nu	N	n
$\xi$	Xi	$\Xi$	x
$\omicron$	Omicron	O	o
$\pi$	Pi	$\Pi$	p
$\rho$	Rho	P	r
$\sigma$	Sigma	$\Sigma$	s
$\tau$	Tau	T	t
$\upsilon$	Upsilon	$\Upsilon$	u
$\phi$	Phi	$\Phi$	ph
$\chi$	Chi	X	ch
$\psi$	Psi	$\Psi$	ps
$\omega$	Omega	$\Omega$	o, long

CHAPTER III.

ON THE PROPRIETY OF ADOPTING A MORE NATURAL ARRANGEMENT AND DELINEATION OF THE STARRY GROUPS.

THE figures of the celestial constellations to which we have now adverted are still depicted in our celestial globes and planispheres, and present, in my opinion, a very awkward and unnatural representation of the starry heavens. It is rather a strange circumstance, that for a period of more than two thousand years the firmament has been contemplated, and the arrangements of the bodies it contains studied, through the medium of bears, serpents, lizards, rams, whales, centaurs, dolphins, flying-horses, three-headed dogs, hydras, dragons, and many other grotesque and incongruous figures. The sublime wonders of the evening sky have thus been associated with a group of mean, ridiculous, and imaginary objects, of which we have scarcely any prototype in nature, and in which there is not the least shadow of a resem-

blance to the objects they are intended to represent. When the young student of astronomy wishes to distinguish particular assemblages of suns and systems of worlds, he is required to connect them in his imagination with wolves, lions, snakes, and numerous fantastical figures, which are bent and twisted into unnatural shapes, which have as little resemblance to the objects in the heavens as the gloom of midnight to the splendors of the meridian sun. Such representations have a tendency to convey to juvenile minds a mean idea of the most august bodies in nature, and of the ample spaces which surround them, and in which they perform their revolutions.

The terms used in any science, the mode of communicating its instructions, and the delineation

tions which such instructions require, ought undoubtedly to be accommodated to the discoveries which have been made in the course of ages, and to the present state and objects of that science; and unless we can show that the terms and figures to which I allude are the best calculated to the present state and objects of astronomical science, and fitted to assist the student in forming natural and correct ideas of the arrangement of the celestial orbs, it is expedient that some change and improvement in this respect should be adopted, in accordance with the new modifications and arrangements which have been introduced into other departments of science. The propriety of introducing some changes in delineating the constellations, and in their nomenclature may perhaps appear from the following considerations:

1. The natural and hieroglyphic figures now in use have no resemblance to the groups of stars they are intended to represent. What resemblance, for example, exists between an eagle, a wolf, a centaur, a flying-fish, or Hercules with his club—and the constellations which bear their names and are attempted to be delineated by their figures? Even when imagination has stretched itself to the utmost in order to fancy a resemblance, it is obliged to represent such creatures in the most unnatural positions; and after all, it is found impossible to bend and twist their wings, and legs, and tails, and claws, in such a manner as to take in all the stars in the group, some pretty conspicuous ones being still left unformed in the intermediate spaces. Beside, the discovery of new stars by the telescope has now completely deranged the figures of the ancient constellations; so that however much the legs, arms, and feet of the figures may be twisted, they cannot be made to coincide with hundreds of stars which are known to exist. The only constellations which may be said to bear a very rude resemblance to the natural figures are Orion and Ursa Major; but even in these the resemblance is very distant. Hence what is commonly called a *bear* is also conceived to resemble a *plow* and a *wagon*, and is, by the vulgar, distinguished by these names. Hence, also, different nations represent the same constellation by different figures:—thus, instead of our hieroglyphic delineations, the Hindus have bespattered the firmament with bedsteads, dogs' tails, ear-rings, couches, elephants' teeth, cats' claws, red saffron, children's pencils, lions' tails, festoons, wheels, razors, pieces of coral, pearls, and other whimsical objects equally appropriate.\*

In a judicious comparison of the figures of the different clusters of stars with any other object, for the purpose of a name or reference, the figure of the particular cluster ought first to be accurately considered, and then an object, having as near a relation to it as possible, should be fixed upon as its representation. But an order exactly the reverse of this seems to have been adopted by the ancients in their arrangement and nomenclature of the constellations. They first fixed upon the heroes, animals, and mythological figures which they intended to place in the celestial vault; and then attempted, if possible, to bend the clusters of stars to correspond with them—a most absurd, unscientific and unnatural procedure. And shall all succeeding astronomers in every nation tacitly give their approbation of such rude and injudicious arrangements, as if they were

unqualified for forming a more scientific and definite outline of the sublime spaces of the firmament?

2. The figures now in use tend to convey a mean idea of the objects they are intended to represent. When the stars were considered as merely a number of tapers or studs fixed in the vault of heaven, solely for the purpose of shedding a few glimmering rays on the earth and adorning the canopy of our habitation, it might not appear quite so incongruous to represent their different groups by "corruptible men, and birds, and four-footed beasts, and creeping things." But now that the astronomer views the stars as so many suns and systems of worlds, dispersed through the immensity of space, the association of such august objects with representations so silly and whimsical as the mythological figures delineated on our globes, produces not only a ludicrous effect by the greatness of the contrast, but for the same reason, tends to lessen the idea of sublimity which naturally strikes the mind on the contemplation of such a stupendous scene. Every one knows how much things great and noble are debased by being placed in intimate connection with little and ignoble objects, and must feel the force of this association in the following lines of Hudibras:

"And now had Phœbus in the lap  
Of Thetis taken out his nap;  
And like a lobster boil'd, the morn,  
From black to red began to turn."

Again—

"Cardan believed great states depend  
Upon the tip of the Bear's tail's end;  
That as she wink'd it toward the sun,  
Strew'd mighty empires up and down."

Again—

"Who made the *Balance*, and whence came  
The *Bull*, the *Lion*, and the *Ram*?  
Did not we hear the *Argo* rig?  
Wake *Dereence's* Portwig?  
Whose livery does the *Cochman* wear?  
Or who made *Cassiopeia's* chair?  
And therefore as they came from hence,  
With us may hold intelligence."

Such an effect the celestial hieroglyphics have a tendency to produce, when placed in association with the august objects of the sky.

3. They tend to lead us back to the dark and rude ages of the world, and to familiarize our minds to those crude, chimerical, and absurd conceptions which ought now to descend into oblivion. The signs of the zodiac and most of the other constellations were invented by the Egyptians or Chaldeans to perpetuate the memory of some of their rude and barbarous heroes, to assist them in their absurd and idolatrous worship, or to serve the foolish and impious pretensions of astrology. In neither of these respects can the celestial hieroglyphics be interesting or instructive to the modern student of astronomical science, but they are, in almost every point of view, associated with opinions, practices, and representations, which deserve the most marked reprobation; they also distract the attention by turning it aside from the direct objects of the science to the investigation of their fabulous history. How ridiculous the story of Calisto and her son Arces, whom the rage of Juno turned into bears, which now circulate about the north pole!—the story of Medusa, whose golden hair Minerva turned into snakes, and of the winged horse which sprang from the blood which gushed out in striking off Medusa's head!—the story of Orion, who was produced from the kids

\* See "Asiatic Researches," Vol. ii, Art. 16—Antiquity of the Indian Zodiac.



of an ox moistened with wine!—the story of the Dragon which guarded the golden apples in the garden of the Hesperides, and was taken up to heaven and made a constellation on account of his faithful services!—the story of Andromeda, of the Swan, of Perseus, and a hundred others of a similar description!

Such is the heaven of the pagans—a common receptacle of all ranks of creatures, real and imaginary, without distinction or order; a wild miscellany of everything that is false, grotesque, and chimerical. Such fantastical groups, which occupy the “houses of the Zodiac,” and other compartments of the sky, may comport with the degrading arts of the astrologer, but they are not only incompetent to the purposes, but completely repugnant to the noble elevation of modern astronomical science. How incongruous, then, is it that such representations, the wildest hallucinations of the human mind, should be blazoned in such brilliant colors upon our globes, and that a considerable portion of our astronomical treatises should be occupied in detailing their mythological history? Because a few shepherds in the plains of Babylon, or on the banks of the Nile, arranged and delineated the heavens according to the first crude conceptions which arose in their minds, are these chimerical representations to guide the astronomers of every nation, and throughout all succeeding generations? It becomes the astronomers of the present day to consider, whether they intend to transmit to the enlightened generations of the twentieth or thirtieth centuries the sublime discoveries of modern times, which have transformed the heavens into an immense assemblage of suns and worlds,—incorporated and disfigured with hydras, gorgons, flying-horses, three-headed dogs, and other “dire chimeras;” or whether they might not be as well qualified as the shepherds of Chaldea to reduce the starry groups, in the concave of the firmament, to a more natural, simple, and scientific arrangement.

4. The constellations, as presently depicted on our globes and planispheres, convey an *unnatural* and complex representation of the heavens, which tends to confuse the imagination of the juvenile student. On some celestial globes which I have inspected, the natural and hieroglyphic figures are so prominently engraved, and the colors with which they are bespattered so deep and vivid, that the stars, appeared not only as a secondary object, but were almost invisible, except on a very minute inspection. The animals were so nicely drawn, and exhibited such a glare of variegated colors, that the sphere appeared more like a young miss's plaything than a delineation of the starry heavens. It seems as if the engraver had been afraid lest his pretty little dogs, and serpents, and scorpions, and flying-horses, and crabs, and lizards, should have been disfigured by the radiated groups of stars which spotted the pretty creatures; and therefore he threw them into the shade, in order that the artificial globe, which a late philosopher calls “a philosophic toy,” might prove nothing more to the fair one, who occasionally twirled it round its axis, than a beautifully-colored ball to fill up a niche in her parlor or bed room. The same thing appears in many of our planispheres of the heavens, on the first opening of which one would imagine he was about to inspect the figures connected with the natural history of animals, or the fantastical representations illustrative of the system of pagan mythology. Whatever may be said of the utility of such delineations it is evident they present a very awkward and *unnatural* representation of the beautiful and varie-

gated scenery of a starry sky; and hence it is that a young person who wishes to acquire a general knowledge of the positions of the principal stars finds it extremely difficult to recognize them by our present maps and planispheres, on account of their being so much interwoven with extraneous objects, and on this account, presenting appearances so very different from what they do in the heavens.

For these and many other reasons, it appears expedient that some change or modification should be adopted in the arrangement and delineation of the celestial orbs. Were any scheme of this kind attempted, it would be proper to proceed on the following principle, among others—namely, to give names to the starry groups from objects which bear the nearest resemblance to the actual figures which appear in the heavens. I shall not presume at present to determine what are the particular objects which might be selected for representing the constellations; as it would require a combination of astronomers to enter particularly into the discussion. It is evident, however, that a number of clusters might be reduced to mathematical figures and diagrams; and in so far as these were found to resemble the starry groups they would form a *natural* representation. For there actually appear in the heaven—triangles, squares, parallelograms, pentagons, crosses, trapeziums, perpendicular and parallel lines, and various combinations of geometrical schemes, some of which might be selected for the purpose proposed. It would be expedient that as many as possible of the old constellations should be preserved entire; such as Orion, Ursa Major, and others; and that those which behooved to be somewhat deranged should be so divided as that two or more of the new-formed constellations should exactly correspond to one of the old, and *vice versa*.

To any proposal of this kind, however, I am aware that many objections would be raised, particularly that it would introduce confusion into the science of astronomy, especially when references are made to ancient catalogues and observations. It is well known however that a similar difficulty has been overcome in reference to the science of *chemistry*. The new nomenclature, which was intended to express the *nature* of the substance by the *name* which is attached to it, though at first scouted by many eminent chemists and philosophers, is now universally adopted, and has introduced both simplicity and precision into the science. The same may be said of the departments of geology, botany, zoology, mineralogy, and meteorology. The principle now proposed in reference to the constellations is materially the same as that which led to the adoption of a new chemical nomenclature; and, with regard to the inconveniences attending a new set of terms, it may be observed, in the words of M. Bergman, that “those who are already possessed of knowledge cannot be deprived of it by new terms; and those who have their knowledge to acquire will be enabled, by an improvement in the language of the science, to acquire it sooner.”

The opposition, however, which is generally made to every innovation, whether in science or religion, the high respect in which everything is held which has the sanction of antiquity, the difficulty of forming such an arrangement as would combine simplicity with accuracy, and meet the approbation of astronomers, will probably postpone the attempt to some distant period. I would therefore propose, in the meantime, as matters now stand, one or other of the following plans for adoption:—1. That the stars be depicted on celestial globes and planispheres in their true po-

sitions, and apparent magnitudes, without being connected with any hieroglyphic delineations; the different constellations still retaining their former names. By this plan, the different clusters, not being encumbered and buried, as it were, in a medley of grotesque and extraneous representations, would appear in their natural simplicity, without distortion and confusion, so that the globe, being rectified to any particular position of the heavens, would appear a *natural* as well as accurate representation of the corresponding orbs of the firmament. To distinguish the boundaries of the constellations, a dotted line might be drawn around them, and each of them receive a very slight tint of coloring, so that their shape and limits may be distinguished at a glance. Or, 2. Instead of engraving the stars on a white ground, as is always done on the globes, let them be engraved on a black or a dark-blue ground, so that the several stars may appear as so many white specks, varying in size according to their apparent magnitudes, with a white border (which might be colored if deemed expedient) around each constellation, to mark its boundaries. On this plan the principal stars in the constellation *Orion*, with its boundary, would appear nearly as represented in the following cut.

Fig. 4.  
North.

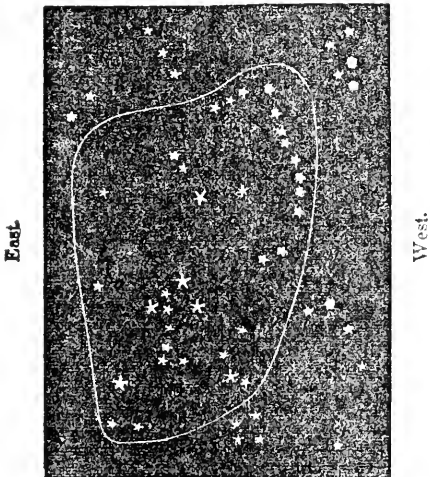

'This mode of delineation would exhibit the most *natural* representation which can be made, on a convex surface, of the appearance of the starry sky. I am fully persuaded that globes, with either of these modes of delineation, particularly the last, would be prized by a numerous class of individuals; as I have seldom conversed with any person on this subject who would not have preferred such a simple and natural delineation to

those which are bespattered with the mythological figures. Should it, however, be deemed necessary, in cases of particular and minute reference, to have globes and planispheres on the common plan, a number of delineations of both kinds might be engraved to suit the taste of different individuals, and those to whom money is no great object would furnish themselves with one of each description, so that the one globe would prove a mutual assistance to the other.\*

That the opinions I have now expressed on this subject are not altogether singular will appear from the following extract from Sir J. Herschel's "Astronomy." "Of course we do not here speak of those uncouth figures and outlines of men and monsters which are usually scribbled over celestial globes and maps, in a rude and barbarous way, to enable us to talk of groups of stars, or districts in the heavens, by names which, though absurd or puerile in their origin, it would be difficult to dislodge them. In so far as they have really any slight resemblance to the figures called up in imagination by a view of the more splendid 'constellations,' they have a certain convenience; but as they are otherwise entirely arbitrary, and correspond to no *natural* subdivisions or groupings of the stars, astronomers treat them lightly, or altogether disregard them, except for briefly naming particular stars, as  $\alpha$  Leonis,  $\beta$  Scorpio, &c., by letters of the Greek alphabet attached to them." And again,—"This disregard is neither supercilious nor causeless. The constellations seem to have been almost purposely named and delineated to cause as much confusion and inconvenience as possible. Innumerable snakes twine through long and contorted areas of the heavens, where no memory can follow them; bears, lions and fishes, large and small, northern and southern, confuse all nomenclature, &c. A better system of constellations might have been a material help as an artificial memory."†

\* The above remarks are abridged from two papers on this subject, which the author communicated twenty years ago to the London "Monthly Magazine" for October, 1818, and January, 1819, Vol. 46, pp. 201, and 500.

† Since the above was written in April, 1838, I am happy to learn that the "British Association for the advancement of Science" has had its attention directed to this subject. At the meeting at New-Castle in August, 1838, it was resolved, "That it is desirable that a revision of the nomenclature of the stars should be made, with a view to ascertain, whether or not a more correct distribution of them among the present constellations, or such other constellations as it may be considered desirable to adopt, may be formed." At the meeting at Birmingham, August, 1839, the committee appointed to report on this subject stated, "That some progress has been made in reforming the nomenclature of the northern constellations; and that the stars in the southern have been commenced laying down on a planisphere, according to their observed actual magnitudes, for the purpose of grouping them in a more convenient and advantageous manner." It is hoped, therefore, that we shall soon be presented with an arrangement and nomenclature of the starry groups, accordant with the sublime conceptions and discoveries of modern astronomy, and which shall present, on our globes and planispheres, a more perspicuous and natural representation of the heavens.

## CHAPTER IV.

### ON THE DISTANCES OF THE STARS.

To measure the length and breadth of an extensive kingdom, and to compute its dimensions, or to determine the distances between two large islands or continents, was formerly reckoned an achievement of considerable magnitude; but to measure the whole earth, to compute its area, and to determine its exact figure and magnitude, were considered as the most astonishing enterprises ever attempted by man, and almost beyond the reach of the powers with which he is endowed. Confined to a small spot in the world in which he dwells, having no scale of measurement, in the first instance, but his own dimensions, or the length of a rod or chain formed from these dimensions, how can he measure spaces hundreds of times greater than the extent of his whole visible horizon? how can he compute the distance and dimensions of places which he has never visited, and some of which he never can visit, and embrace the whole amplitude of a world which has never been thoroughly explored? The height of his body is but a fathom, and the length of his chain but a score of fathoms, and such measures dwindle into mere points when compared with the dimensions of the earth. Hence it happened that many ages elapsed before the figure and dimensions of the world in which we dwell were nearly ascertained. The powers of the human mind, however, when called into action and properly exercised, are not only capable of such enterprises, but adequate to the performance of still more elevated achievements. When the mind of man is determined on the pursuit of knowledge, and bent upon improvement, difficulties, however great, only serve as incitements to action and perseverance, and to stimulate his energies to their highest pitch of exertion. He multiplies small measures until he arrives at greater; he combines units into tens, tens into hundreds, hundreds into thousands, and thousands into millions. He combines lines into angles, angles into triangles; compares triangles, squares, and circles together; ascertains their peculiar properties and relations; and, from the conclusions he deduces, constructs instruments and ascertains principles which enable him not only to measure the dimensions of this lower world, but the magnitudes and distances of the globes which roll around him in the heavens.

There is no saying at what point the human faculties will stop when once they are aroused to active operation, and stimulated to exert all their energies. We have not only ascertained the bulk of the terraqueous globe, its spheroidal figure, its diurnal and annual motions, and the relation in which it stands to other bodies in the universe, but we have determined the dimensions of the solar system, and the distances and magnitudes of most of the bodies it contains, so that we can now speak with as much certainty of the distance of the sun, or of Jupiter and Saturn, as we can do of the distance of London from Paris, or of the distances of any two places on the surface of the earth. This is an achievement which

at first view might have appeared beyond the power of human genius to accomplish; but by the unwearied observations of modern astronomers, and the application of mathematical principles to such observations, they have been enabled to trace the exact movements of the machinery which is in operation around us, and to determine with precision the relative distance and position of every planet within the system of the sun. There are limits, however, beyond which it is difficult for the human faculties to penetrate. The planetary system comprises an area so vast that imagination is almost lost in the conception. A circle drawn around its circumference would measure more than eleven thousand millions of miles; and a body moving at the rate of thirty miles an hour would require above forty-two thousand years to complete the circuit; still these vast dimensions are within the limits of measurable distance. But when we attempt to pass beyond the boundaries of this system into the illimitable spaces which lie beyond, all our usual modes of computation begin to fail, and the mind is overpowered and bewildered amidst boundless space, and the multiplicity of orbs which fill the regions of immensity. We can tell that some of the nearest of these orbs are not within a certain distance, but how far they may lie beyond it the most expert astronomer has never yet been able to compute.

The principal mode by which the distance of the fixed stars has been attempted to be determined is by endeavoring to ascertain whether any of them have an *annual parallax*. I have already explained the mode by which the distances of the sun, moon, and planets is determined by means of the *horizontal parallax*, or the angle under which the earth's semi-diameter is seen at any of these bodies.\* But such a mode is altogether inapplicable to the fixed stars, whose distances from the earth is so great that the horizontal parallax is quite imperceptible. Astronomers have therefore attempted to find a parallax by using the whole diameter of the earth's annual orbit as a *base line*,—namely, one hundred and ninety millions of miles,—and endeavoring to ascertain whether any of the fixed stars appear to shift their position when viewed from the opposite extremities of this line. The nature and mode of this investigation will appear from the following explanations:

The axis of the earth extended, being carried parallel to itself during its annual revolution round the sun, describes a circle in the sphere of the fixed stars equal to the orbit of the earth. Thus (fig. 5), let  $ABCD$  be the orbit of the earth,  $S$  the sun, the dotted lines the axis of the earth extended; this axis, when the earth is at  $A$ , points at  $a$  in the sphere of the heavens; when the earth is at  $B$ , it points at  $b$ ; when at  $C$ , it points at  $c$ ; and when at  $D$ , it points at  $d$ ; so that in the course of a year it describes the circle  $a b$

\* "Celestial Scenery," pp. 110, 111.

$cd$  in the sphere of the heavens, equal to the circle  $ABCD$ . But although the orbit of the earth, and consequently the circle  $abcd$ , be immensely large, no less than many millions of miles in diameter, yet it is but a point in comparison of the boundless sphere of the heavens. The angle under which it appears to an inhabitant of the earth is insensible by any instruments or observations that have hitherto been made, and therefore the celestial poles appear in the same points of the heavens during the whole of the earth's annual course. The star  $H$  is nearer the point  $a$  than it is to the point  $c$  by the whole length of the line  $ac$ , yet if this line  $ac$ , great as it is when viewed from the earth, should occupy no sensible space in the sphere of the heavens, the star will appear at the same distance from the pole throughout every portion of the annual revolution, and consequently will have no parallax,—which is found to be the fact.

If the annual parallax of a fixed star were sensible, the star would appear to change its place so as to describe a small ellipse in the sphere of the heavens in the course of a year, or an annual revolution of the earth. Thus, let  $GEFI$  (fig. 6) be the orbit of the earth, and  $K$  the star to be observed,—if we imagine a straight line to be drawn from the earth at  $G$  through the star to a point in the heavens, as at  $i$ , that visual line  $G$

would appear to move one-half of the year according to the order of the signs, and contrary to the order of the signs during the other half,—somewhat similar to the appearance which the moons of Jupiter present when moving between the opposite points of their orbits. If therefore the stars were at a moderate distance from the earth, so that the diameter of the earth's orbit,  $GF$ , bore a sensible proportion to that distance, the star would be found at one time of the year, suppose the month of December, at the point  $i$ , and at the opposite season, in the month of June, at the point  $h$ ; and if the angle  $iKh$ , which is equal to the angle  $GKF$  could be found, it would constitute what is termed the *annual parallax*; and having obtained this parallax, and knowing the extent of the base line  $GF$ , or the diameter of the earth's orbit, the distance of the stars whose parallax was ascertained could then be determined by an easy process in trigonometry; for as radius: is to the sine of the angle  $iKh = GKF$ : so is the diameter of the orbit of the earth, 190,000,000 of miles: to a fourth number, which would express the distance of the particular stars from our globe.

But this angle, in respect to any of the stars, has never yet been ascertained; although astronomers for more than a century past have used the most accurate instruments which ingenuity could contrive, and the most unwearyed observations in order to determine it.

Galileo appears to have been the first who thought of trying whether the annual parallax of the stars were discoverable. Taking for granted that the stars are placed at different distances from the earth, and that those stars which are nearest will appear the largest, he suggested that, by observing with a telescope two stars very near each other, one of the greatest and the other of the least magnitude, their apparent distance from each other might perhaps be found to vary as they were viewed from different parts of the earth's orbit at different times of the year; but no change of position whatever was at that period perceived.

If any change of this kind were perceptible, it behooved to be a change either in the longitude or latitude of the stars fixed upon as the subject for observation. These are found, not directly, but by first determining their declination and right ascension. The declination of a star is found by taking its meridian altitude, and subtracting the height of the equator; the right ascension is found by the time of its coming to the meridian.\* We have thus two methods pointed out of attempting to determine the annual parallax of the stars: *one*, by observing if any change can be discovered in the meridian altitudes of the same star at different times of the year; the *other*, by examining whether the intervals of time between any two stars coming to the meridian are equal throughout the year. If there be any sensible change of declination in any of the stars, it must be greatest in those which are near the poles of the ecliptic; but the change of right ascension must be greatest in stars in the solstitial colure, and nearest the pole of the equinoctial.

\* The *latitude* of a star is its distance from the *ecliptic*, either north or south, counted toward the pole of the ecliptic. Its *longitude* is its distance from the first point of Aries, reckoned eastward on the *ecliptic*. The declination of a star is its distance from the *equinoctial* north or south, and the greatest declination it can have is  $90^\circ$ . Its *right ascension* is its distance from the first point of Aries, reckoned on the *equinoctial* eastward round the sphere of the heavens, or that degree of the equinoctial which comes to the meridian with the star. By the right ascension and declination the situation of stars in the heavens is determined, as that of places on the earth by longitude and latitude.

Fig. 5.



Fig. 6.

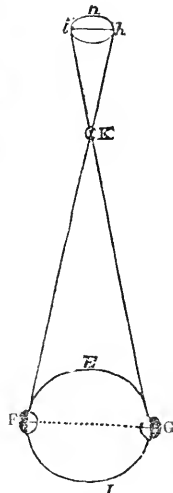

$i$  being carried along with the earth in its annual motion, will describe the ellipse  $hni$ ; in other words, the motion of the earth round its orbit  $GEFI$  will make the star appear to go round the ellipse  $hni$ . If the star  $K$  were in the pole of the ecliptic, the ellipse it described would have the same eccentricity as the orbit of the earth, and consequently would differ very little from a circle; if it were at any distance from the pole of the ecliptic,\* the greater that distance, the more oblong would be the ellipse. If the star were in the plane of the ecliptic, the ellipse would become a straight line, as  $ih$ , in which the star

\* The *pole* of the ellipse is that point in the heavens which is furthest distant from the plane of the earth's orbit, or  $90^\circ$  from every part of it, as the north pole of the earth is the point distant  $90^\circ$  from the equator. The pole of any circle is a point on the surface of the sphere  $90^\circ$  distant from every part of that circle of which it is the pole.

The following is the plan by which the discovery of the annual parallax, by the *change of the declination* of the stars, may be attempted. Let a telescope be placed perpendicular to the horizon, and through this instrument, when accurately adjusted, observe some star in or near the solstitial colure,\* which passes through the zenith, or very near it. If the parallax of the star be sensible, there will appear a difference in its altitudes at different periods of the year, and its altitudes at the two solstices† will differ most from each other. In the month of *June* a star that passes through the zenith of any place, in north latitude, will in *December* pass *south* of the zenith, and a star that in *December* passes through the zenith will in *June* pass to the north of it, if there be any sensible parallax.

The celebrated Dr. Robert Hook was among the first who suggested this method of attempting to find the parallax of the stars. In the year 1669 he endeavored to put it in practice at Gresham College, with a telescope thirty-six feet in length. His observation was made on the 6th of July, on the bright star in the head of *Draco* marked *Gamma*. On that day it passed  $2' 12''$  north of the zenith. On July 9th it passed at the same distance as before. On the 6th of August the star passed north of the zenith  $2' 6''$ , and on the 21st of October it passed  $1' 48''$  north of the zenith. But at that period astronomical instruments were not constructed with such accuracy as to enable the observer to determine with precision the quantity of so small angles; and even Dr. Hook himself could place no great reliance on such observations. In the year 1689, Flamsteed, the astronomer royal, commenced similar observations with an instrument adapted to a refracting telescope seven feet long, and, after numerous observations, he supposed that he found the pole-star nearer the pole in December than in the months of April, May, July, August, or September; and that its apparent distance from the pole was greater in April than in September, and greater in July and May than in April; and from the whole of his observations he deduced that its apparent distance from the pole in June must be forty-six seconds different from that in December. But even Flamsteed himself speaks of these observations with a great deal of diffidence, owing to his doubts about the regular divisions of his instruments.

From these observations of Hook and Flamsteed, supposing them to be nearly correct, Mr. Whiston computed that the greatest annual parallax of a star in the pole of the ecliptic is forty-seven seconds; and hence he calculated the distance of such stars to be about 9000 *semidiameters* of the earth's orbit, then estimated at eighty millions of miles, or about 700,000,000,000, that is seven hundred thousand millions of miles, — a distance so great that it would require a cannon ball, moving 500 miles an hour, more than 160,000 years to move across this immense interval. But we have reason to believe that the distance of the nearest stars from our globe is at least forty times the distance now stated; for

modern astronomers would long since have determined the annual parallax had it been nearly so great as Hook and Flamsteed supposed; nay, had it amounted to  $2''$  instead of  $47''$  this grand problem, as it respects the nearest stars, would have been resolved.

The human mind, when ardently engaged in the pursuit of any object, is seldom deterred by difficulties; and astronomers in particular, notwithstanding the intricacies and difficulties connected with many of the objects of their investigation, have persevered in their observations and researches, and have not unfrequently arrived at the most important and unexpected results. In the year 1725, Mr. Moynaux, doubtful of the accuracy of the observations of Hook and Flamsteed, began a series of observations, to ascertain, if possible, the true annual parallax. Assisted by Dr. Bradley, he placed a telescope of twenty-four feet long perpendicularly at his house at Kew, and began to observe the same bright star in *Draco* as Hook had done. From the 31 of December that year it was found that the star did not sensibly change its distance from the zenith for several days. On December 17th it passed a little more southerly, and continued gradually to pass more and more southerly at every transit over the meridian until the beginning of March, when it was found to pass twenty seconds more southerly than at the time of the first observation. About the middle of April it appeared to be returning toward the north, and at the beginning of June it passed the meridian at the same distance from the zenith as in December, when it was first observed. From that time it appeared more and more northerly at every transit until September following, being then twenty seconds more *northerly* than in June, and no less than thirty-nine seconds more *northerly* than in March. From September the star returned toward the south until it arrived, in December, at the same situation in which it was found a twelvemonth before.

Fig. 7.

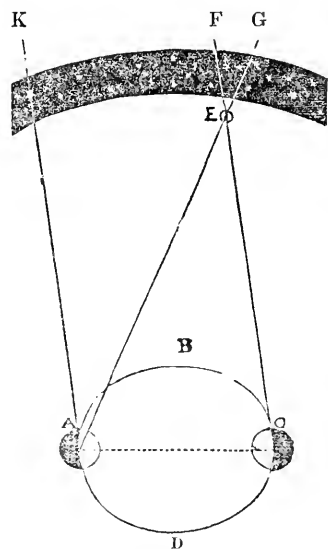

The result of these observations, so different from what was expected, was a matter of great surprise to the observers; for it appeared that the star was thirty-nine seconds more northerly in

\* The *colures* are two great circles passing through the poles of the world; one of them passes through the equinoctial points Aries and Libra, which is called the *equinoctial colure*; the other through the solstitial points Cancer and Capricorn, called the *solstitial colure*. They are drawn on all celestial globes and planispheres.

† The *solstitial points*, or *solstices*, are where the ecliptic touches the first points of Cancer and Capricorn. The summer solstice is on the 21st of June; the winter solstice is on the 21st of December.

September than in March, *just the contrary to what it ought to appear by the annual parallax of the stars.* This may be illustrated by the following figure:

Let  $A B C D$  represent the orbit of the earth, and  $A$  and  $C$  the place of the earth at two opposite periods of the year; then a fixed object at  $E$  will be seen from the earth at  $A$ , in the line  $A E$ , which will point out its apparent place at  $G$  in the concave expanse of the sky. But at the opposite period of the year it will be seen from the earth at  $C$  in the line  $C E$ , which will project its place in the heavens at  $F$ ; so that while the earth has passed from  $A$  to  $C$  the object will appear to have moved from  $G$  to  $F$ , through the space  $G F$ , provided there be any sensible parallax. Now, in the case of the observations stated above, the observers who in *September* saw the star at  $F$ , did in *March* following observe it at  $K$ , in the right line  $A K$ , parallel to  $C F$ , and not at  $G$ , where it ought to have appeared by the parallactic motion; so that, instead of finding a parallax, they found a result directly opposite to what they expected, which exceedingly perplexed the observers, and one of them, Mr. Molyneux, died before the true cause of it was discovered.

Some time afterward, Dr. Bradley repeated the same observations with an instrument of great accuracy, to which was appended a telescope twelve and a half feet long. With this instrument, which was so nicely adjusted that he could depend upon it even to half a second, he continued his observations for more than two years, not only on the bright star in *Draco*, above alluded to, but on many other stars, and always observed the same appearances and arrived at the same results. At last, after many reflections and conjectures on the subject, he arrived at the following conclusion—namely, that the phenomenon he had observed was owing to “the progressive motion of light, and the sensible proportion which its velocity bears to the velocity of the annual motion of the earth.” In other words, that the motion of light, combined with the progressive motion of the earth in its orbit, causes the stars to be seen in a different position from what they would be if the eye were at rest. This position, after it was explained and demonstrated, was considered as one of the most brilliant discoveries which had been brought to light during the last century. It agrees with the velocity of light which had been deduced from the eclipses of *Jupiter's* satellites, and it amounts to a sensible demonstration of the annual motion of the earth. The observations which led to this discovery likewise prove the immense distance of the stars from the earth; for Dr. Bradley assures us, from the accuracy with which they were conducted, that if the annual parallax had amounted to so much as *one second*, he should have discovered it.

If, then, the greatest annual parallax of the nearest stars does not amount to one second, their distance must be immense. Supposing the parallax to be exactly one second, the distance of a star having this parallax will be found by the following trigonometrical proportion:—As the sine of  $1''$  is to radius :: so is the semidiameter of the earth's orbit to a fourth number, which expresses the distance of the star. Now, a parallax of one second determines the object to be 212,000 times farther from the earth than is the sun. The distance of the sun is 95,000,000 miles, which, multiplied by 212,000, produces 20,140,000,000,000, or more than *twenty billions* of miles. This distance is absolutely certain: it follows, as a matter of course, if the annual parallax were determined to be one second, it is the *very least distance*

at which any of the fixed stars can be situated from our globe; but as the parallax does not amount to this quantity, their distance must be much farther than what is here stated, perhaps not less than double or treble that distance. We may acquire some faint idea of the immense distance stated above by considering that a *gun ball*, flying with uniform velocity 500 miles every hour, would require *four millions, and five hundred and ninety five thousand years* before it could reach an object at the distance we have stated. Such are the ample and inconceivable dimensions of the spaces of the universe.

Several other methods have been resorted to by astronomers in order, if possible, to determine the distance of the stars, but most of them are founded upon assumptions which have not yet been proved. The celebrated Huygens, as recorded in his “*Cosmotheoros*,” despairing of being able to find an annual parallax, resorted to the following method:—supposing that the star *Sirius*, one of the brightest fixed stars in the heavens, be equal in luster and magnitude to the sun, he endeavored to diminish the apparent diameter of the sun to the eye, so that it should appear *10* larger or brighter than *Sirius* appears to a *common* observer. For this purpose he closed *each* end of a twelve feet tube with a very thin plate, in the middle of which he made so small a hole that a very minute glass globule being put into it, so very small did the sun appear to the eye placed at the other end of the tube, that the light transmitted to the eye seemed not more splendid than that which we behold transmitted from *Sirius* with the naked eye. Having calculated, on the principles of optics, the quantity of diminution of the sun's apparent diameter, he found it to be only the 1-27664th part; or, the light and diameter of the sun appeared 27,664 times smaller than what we daily see. Hence he concluded that were the sun at 27,664 times his present distance from us, he would appear as small as *Sirius*; and consequently, if *Sirius* be of the same magnitude as the sun, the distance of that star must be 27,664 times greater than the distance of the sun from the earth, or 2,628,080,000,000,—that is, two billions, six hundred and twenty eight thousand, and eighty millions of miles. This method of determining the distance of the stars depends upon two assumptions:—1st, that the sun and *Sirius* are equal in magnitude; and 2d, that the eye judged correctly of the equality of the small intercepted portion of the sun to *Sirius*; both of which must be considered as uncertain. But it corroborates the general position of the very great distance of the stars.

On a principle somewhat similar, but by experiments conducted with far greater accuracy, Dr. Wollaston endeavored to determine the same problem in relation to the stars. “This gentleman,” Sir J. Herschel remarks, “by direct photometrical experiment, open, as it would seem, to no objections, has ascertained the light of *Sirius*, as received by us, to be to that of the sun as 1 to 20,000,000,000. The sun, therefore, in order that it should appear to us no brighter than *Sirius*, would require to be removed 141,400 times its actual distance. We have seen, however, that the distance of *Sirius* cannot be so small as 200,000 times that of the sun. Hence it follows that, upon the lowest possible computation, the light really thrown out by *Sirius* cannot be so little as *double* that emitted by the sun; or that *Sirius* must, in point of intrinsic splendor, be equal to *two suns*, and is in all probability, vastly greater.”

The late Sir William Herschel proposed another method of determining the annual parallax by

means of *double stars*, which he supposed would be free from the errors of other methods, and of such a nature that the parallax, even if it should not exceed the tenth part of a second, may still become visible. The following figure and description will convey a general idea of this method:

Fig. 8.

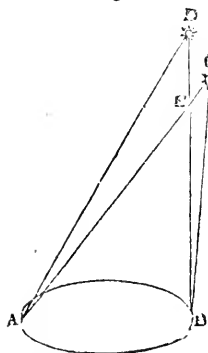

Let *A* and *B* (fig. 8) represent the earth at two opposite points in its orbit, and *C* and *D* two stars of different magnitudes. Then, if when the earth is at *B*, the two stars appear to us near each other, as at *C* and *E*, it was thought that when the earth arrived at *A* the two stars might appear farther apart, as at *C* and *D*; in other words, that the angles at which they would appear to us in the two cases would be different, the angle *D A C* being larger than the angle *D B C* in which case the angle of parallax might be computed. But it does not appear that any difference in the angles referred to has yet been found, or that any definite conclusions respecting parallax have hitherto been deduced from this method, excepting the general position that the stars are at too great a distance to be subjected to our calculations, or that our angular instruments are still in too imperfect a state to detect so small an angle as that of the annual parallax.

While writing the above (December, 1835), I perceived an announcement in certain literary journals, that Professor Bessel, of Königsberg, had addressed a letter to Sir John Herschel, which was immediately communicated to the Royal Astronomical Society, containing an account of the discovery of the annual parallax and the observations on which it was founded. In the introduction to this communication Professor Bessel says—"After so many unsuccessful attempts to determine the parallax of a fixed star, I thought it worth while to try what might be accomplished by means of the accuracy which my great Fraunhofer heliometer gives to the observations. I undertook to make this investigation upon the star 61 *Cygni*, which, by reason of its great proper motion, is perhaps the best of all, which affords the advantage of being a double star, and on that account may be observed with greater accuracy, and which is so near the pole that, with the exception of a small part of the year, it can always be observed at night at a sufficient distance from the horizon." The professor began his observations in September, 1834, but various circumstances prevented them from being regularly continued at that period. They were resumed in 1837 with certain hopes of success. He selected among the small stars which surrounded the double star 61 *Cygni* two stars between the ninth and tenth magnitudes, of which one (*a*) is nearly perpendicular to the line of direction of the double star, the other (*b*) nearly in this direction. He measured with the heliometer the distances of these stars from the point which bisects the distance between the two stars 61 *Cygni*, and generally repeated the observations sixteen times every night, and when the atmosphere was unusually steady he made more numerous repetitions. The places of both stars, referred to the middle point

of the double star, he calculated, for the beginning of 1838, to be—

Distance.	Angle of Position.
<i>a</i> 461".617	201° 29' 21"
<i>b</i> 706".279	109° 22' 10"

In these observations, he concentrated his attention as far as he could on the *distance* of the small stars from the double star, as being the most important point to be ascertained. His communication contains tables of all his measures of distance, freed from the effects of refraction and aberration, and reduced to the beginning of 1838.

It would be uninteresting to the general reader to enter into all the details of observations, corrections, and calculations which Professor Bessel's communication contains, as they can only be understood by practical astronomers. I shall therefore only state his general conclusion, which seems to be legitimately deduced from his observations and reasonings, and may be considered at least as a very near approximation to the point, if not perfectly correct. The result then is, that the annual parallax of the star 61 *Cygni* is 0".3135; that is, somewhat less than *one-third* of a second. It follows that the distance of this star from the sun is 657,700 times the mean distance of the earth from the sun; and as the distance of the sun from the earth is 95,000,000 of miles, this number multiplied by the former produces 62,481,500,000,000, or *sixty-two* BILLIONS, *four hundred and eighty-one thousand five hundred* MILLIONS of miles, which is the distance of the star 61 *Cygni* from the sun, and which of course is nearly about the same distance from the earth; the earth being in one part of its course ninety-five millions of miles nearer the star than this distance, and in the opposite part of it ninety-five millions of miles beyond it. This, I have no doubt, will be considered as one of the most interesting and splendid discoveries which have been made in astronomy for a century past. It lays a foundation for precise and definite conceptions of the distances of some of the stary orbs, of the amplitude of the celestial regions, and of the magnitude and grandeur of those countless orbs which diversify the spaces of immensity. It likewise proves to a demonstration the annual motion of the earth round the sun, and all the principles and phenomena with which it is connected, as well as corroborates the general views of former astronomers respecting the immense distance of the fixed stars.

Professor Bessel concludes his communication in these words:—"As the annual proper motion of *a Cygni* amounts to 5".123 of a great circle, the *relative* motion of this star and the sun must be considerably more than sixteen semidiameters of the earth's orbit [that is, one thousand, five hundred and twenty millions of miles], and the star must have a constant aberration of more than 52". When we shall have succeeded in determining the elements of the motion of both the stars forming the double star, round their common center of gravity, we shall be able to determine the sum of their masses. I have attentively considered the preceding observations of their relative positions, but I consider them as yet very inadequate to afford the elements of the orbit. I consider them as sufficient only to show that the annual angular motion is somewhere about two-thirds of a degree, and that the distance at the beginning of this century had a minimum of about 15". We are enabled hence to conclude that the time of a revolution is more than 540 years, and that the semi-major axis of the orbit is seen under an angle of more than 15". If, how-

ever, we proceed from these numbers, which are merely *limits*, we find the sum of the masses of both stars less than half the sun's mass. But this point, which is deserving of attention, cannot be established until the observations shall be sufficient to determine the elements accurately. When long-continued observation of the places which the double star occupies among the small stars which surround it shall have led to the knowledge of its center of gravity, we shall be enabled to determine the two masses separately; but we cannot anticipate the time of these farther researches. I have here troubled you with many particulars; but I trust it is not necessary to offer any excuse for this, since a correct opinion as to whether the investigation of the parallax of 61 *Cygni* has already led to an approximate result, or must still be carried further before this can be affirmed of them, can only be formed from a knowledge of these particulars. Had I merely communicated to you the result, I could not have expected that you would attribute to it that *certainty* which, according to my own judgment, it possessed."

The distance inferred from the parallax ascertained by Bessel is more than three times greater than what was formerly considered the *least distance* of any of the fixed stars. In order to acquire some rude conceptions of this distance, it may not be inexpedient to illustrate it by the times which certain moving bodies would require to move along such a space. *Light* is the swiftest moving body with which we are acquainted; it flies from the sun to the earth, a distance of ninety-five millions of miles, in about eight minutes, or at the rate of 192,000 miles every moment of time; yet light, incomprehensibly swift as its motion is, would require ten years and 114 days to fly across this mighty interval; so that if the star 61 *Cygni* were supposed to be only just now launched into existence, it would be more than ten years before its light could reach the distant globe on which we dwell, so as to appear like a small star twinkling in our sky. Suppose a cannon ball to move 500 miles every hour without intermission, it would require fourteen millions, two hundred and fifty-five thousand, four hundred and eighteen years before it could move across the same interval. But to come to motions with which we are more familiar: suppose a steam-carriage to set out from the earth with a velocity of twenty miles an hour, or 480 miles a day; at this rate of motion, continued without intermission, it would require 356,385,466, or three hundred and fifty-six millions, three hundred and eighty-five thousand, four hundred and sixty-six years before it could pass from our globe to the star alluded to above—a number of years sixty-one thousand times greater than the whole period which has elapsed since the Mosaic creation.

Such distances are amazing, and almost terrifying to the human imagination. The mind is bewildered, confounded, and almost overwhelmed, when attempting to form a conception of such portions of immensity, and feels its own littleness, the limited nature of its powers, and its utter incapacity for grasping the amplitudes of creation; but although it were possible for us to wing our flight to such a distant orb as that to which we have referred, we should still find ourselves standing only on the extreme verge of the starry firmament, where ten thousands of other orbs, a thousand times more distant, would meet our view. We have reason to believe that a space nearly equal to that which we are now considering intervenes between most of the stars which diversify

our nocturnal sky. The stars appear of different magnitudes; but we have the strongest reason to conclude that in the majority of instances this is owing, not to the difference of their real magnitudes, but to the different distances at which they are placed from our globe. If, then, the distance of a star of the first or second magnitude, or those which are nearest us, be so immensely great, what must be the distance of stars of the sixteenth or twentieth magnitudes, which can be distinguished only by the most powerful telescopes? Some of these must be several thousands of times more distant than the star 61 *Cygni*, whose distance now appears to be determined. And what shall we think of the distance of those which lie beyond the reach of the most powerful telescopes that have yet been constructed, stretching beyond the utmost limits of mortal vision, within the unexplored regions of immensity? Here even the most vigorous imagination drops its wing, and feels itself utterly unable to penetrate this mysterious and boundless unknown.

The vastness of the spaces and greatness of the distances to which we have adverted ought not, however, to prevent any one from acquiescing in the statements we have now made; for space is boundless,—absolutely infinite. A seraph might wing its flight with the swiftness of light for millions of years through the regions of immensity, and never arrive at a boundary where it might be said, "Hitherto mayest thou approach, but no farther;" and we have reason to believe, from what we already know of the Creator and his works, that during the whole course of such an excursion, new objects and new scenes of glory and magnificence would be continually rising to his view. To suppose otherwise would be to set boundaries to space, and to prescribe limits to the infinite perfections of the Divinity. That incomprehensible Being who formed the universe fills immensity with his presence; his power and wisdom, and all his other perfections, are *infinite*; and therefore we should expect that the plans on which he has constructed the systems of the universe should be like himself, vast, boundless, and inconceivable by mortals. Were we to find the plans of the universe circumscribed like those which were represented by the ancient astronomers,—who imagined the firmament a solid sphere with a number of tapers whirled round the earth,—we should be apt to think that the Creator of the world was a limited being; but when we contemplate the vast amplitude of planetary systems, and the immense spaces by which they are separated from each other, we behold plans and operations which are in perfect unison with the immensity of his nature, with his boundless power, his uncontrollable agency, and his universal presence. Wherever we turn our eyes throughout the scene of nature, and fix our attention on its plans and movements, we uniformly find the Creator *acting like Himself*; and in no case is this more strikingly displayed than in the grandeur and magnificence of the orbs of heaven, and the *immense spaces with which they are surrounded*.

This is likewise the representation which the Scriptures give us of the immensity and incomprehensible nature of the Deity. "Great is Jehovah and of great power; his understanding is infinite; his greatness is unsearchable." He is not only "high above all nations," but "his glory is above the heavens." "He dwelleth on high, and humbleth himself to behold the things" not only that are "on the earth," but even "the things that are in the heavens." Vast



as the celestial spaces are, "he meted out heaven with the span," and "stretched forth the heavens alone." "Among the gods there is none like unto thee, neither are there any works like unto thy works." "Canst thou by searching find out God? Canst thou find out the Almighty to perfection? Who can utter the mighty operations of Jehovah? Who can show forth all his praise? Lo, these are but parts of his ways, but the thunder of his power, or the full extent of his omnipotence, who can comprehend?" In relation to a Being who is thus described, we can expect nothing but what is wonderful and incomprehensible by finite minds. The declarations of inspired men bear testimony to the discoveries of astronomy as in perfect unison with the attributes of the Divinity, so that science and revelation completely harmonize in the views they unfold of the plans and arrangements of the Deity, and of the immense spaces which intervene among the systems of the universe.

Whether man will ever be permitted to traverse any of the vast spaces of the universe, to which we have now adverted, is a question which is at present beyond our province to resolve. In our present state of corporeal organization it is impossible to wing our flight even to the nearest celestial orb in that system of which we form a part, much less to the distant starry regions. How pure spirits, disconnected with material vehicles, may transport themselves from one region of creation to another, it is impossible for us, in the present state, to form a conception. But it is possible to conceive of a system of organization far more refined than the present, and susceptible of a power of motion far surpassing what we have an

opportunity of witnessing in this terrestrial sphere—a locomotive power which might enable an intelligent agent to keep pace with the rapid motions of the celestial orbs. We have only to suppose organical vehicles constructed with matter far more subtle and refined than hydrogen gas, or the ethereal fluid, and approximating to the tenacity of light itself. As we find animalculæ many thousands of times less than the least visible point, their bodies must be constructed of materials extremely subtle and refined; and hence we may infer that the same Allwise Intelligence who formed such minute and refined structures, can with equal ease construct a material organization for the residence of a rational soul out of the finest materials which creation can supply, and endow it with a capacity of rapid motion superior to that of some of the celestial globes which roll around us. It is not improbable that angelic beings are connected with such a system of material organization, which enables them to move with rapidity from one part of creation to another; and it is possible that man, in a future world, may be invested with such vehicles and such powers of rapid motion. At the same time, even with such locomotive powers, only a small portion of the universe could be supposed to be visited or explored, even after a lapse of ages. It is highly probable that, at this moment, there is not a single subordinate intelligence, even of the highest order of created beings, who is acquainted with every region of universal nature and the objects it contains, and that the greater part of the vast universe, with its scenery, movements, and inhabitants, is known only by Him who formed it by his power and fills it with his presence.

## CHAPTER V.

### ON THE MAGNITUDE OF THE STARS.

In our attempts to ascertain the *magnitudes* of any of the heavenly bodies, we must first endeavor to determine the distances at which they are placed from our abode; and in the next place we must measure, as accurately as possible, the *apparent diameters* of the bodies whose magnitudes we wish to determine. The extreme difficulty of determining these two points, in certain instances, on account of the smallness of the angles which require to be measured, has hitherto prevented us from ascertaining with precision the real magnitudes of the bodies connected with the sidereal heavens. We formerly were led to conclude on good grounds, that their distances were almost immeasurably great, and consequently that, as they emit a certain degree of splendor to our eye, even from such remote distances, their *bulk* must be immensely great. But no precise conceptions could be formed as to this point so long as the annual parallax of some of the stars remained undetermined.

The annual parallax of the star 61 *Cygni* being now in all probability ascertained (as stated in the preceding chapter), we are in possession of certain *data* which may lead to the determination of the *real magnitude* of that body. But a difficulty still remains. The stars are found to have no sensible diameters. When viewed through

telescopes of the greatest power, they present no visible discs, or well-defined surfaces to the eye, as the planets do, when viewed through such instruments, but appear only as so many shining and undefined points. When they are viewed through a telescope of moderate size, their diameter appears less than when examined by the naked eye, but considerably more brilliant. When we view them with a telescope of greater power, the apparent diameters will be somewhat increased, but not according to any regular proportion, as happens in the case of the planets; and even when seen with the same power, through different telescopes, their apparent magnitudes are not precisely the same. Sir William Herschel, who viewed these bodies under almost every aspect, uniformly found that their diameter was less in proportion as the higher powers were applied; and the smallest proportional diameter he ever obtained was when he employed the extraordinary power of 6450 times. From such observations it appears that the apparent diameters of the fixed stars do not arise from any sensible disc, but from other causes with which we are not acquainted. Dr. Halley remarks that "the diameters of Spica Virginis and Aldebaran (two stars of the first magnitude) are so small, that when they happen to immerse behind the dark edge of

the moon, they are so far from losing their light gradually, as they must do if they were of any sensible magnitude, that they vanish at once with all their lustre, and emerge likewise in a moment, not small at first, but at once appear with their full light, even although the emersion happen when very near the cusp, where, if they were four seconds in diameter, they would be many seconds of time in getting entirely separated from the limb. But the contrary appears to all those who have observed the occultations of those bright stars.\* Every one who has been in the habit of viewing the starry firmament with good telescopes will at once admit that, although that instrument brings to view numerous stars which the unassisted sight cannot perceive, yet they appear only as luminous points with no well-defined sensible diameters, although their light is much more brilliant than to the naked eye.

Hence the difficulty of determining, with precision, the real magnitudes of any of the fixed stars. From their immense distance we are perfectly certain that they are bodies of immense size, otherwise they would be altogether invisible from our terrestrial sphere, or from any part of the solar system. But we have hitherto obtained no sufficient data for estimating their exact size, as we have done in relation to the globes which compose the planetary system. Since, then, the apparent diameters of the stars, even those of the first magnitude, are so small as not to amount to a single second, we cannot hope, in the meantime, to determine their measure with any degree of certainty. We may assign them a measure which we certainly know they do not exceed, but we cannot be sure that that measure is not too great. All luminous objects appear larger than those of the same dimensions which are opaque. The planet Mercury, when in its greatest brightness, appears larger than when it is seen to pass, like a dark spot, across the disc of the sun, although it is nearest the earth in this last position. The apparent diameters of the fixed stars are much smaller than they have generally been supposed by those who have attempted to measure them. Yet small as they are, their real magnitude must be very great, since they are visible to our sight at the immense distance at which they are placed. In proportion to the greatness of their distance, and the smallness of their apparent diameters, will be their real magnitudes. If we suppose the apparent diameters of any of the stars observed by Dr. Bradley to be equal to the  $49,000^{\text{th}}$  part of the sun's apparent diameter or  $\frac{1}{29}$  of a second—which is a probable supposition for a star of the second magnitude,—it will follow that such a star is equal to the sun in magnitude. For, if the sun were removed to the distance at which such a star is situated, he would appear no larger than those twinkling points, nay, would perhaps disappear altogether from our view. From all the observations and reasonings that have been entered into on this subject, we have no proofs that any of the stars are less than the sun, but it is more probable that many of them equal and even far surpass that luminary in their real dimensions and splendor. Having obtained the parallax of 61 *Cygni*,\* if we could find the exact apparent diameter of that star, its real bulk could be calculated with as much ease and certainty as the bulk of the sun, or moon, or any of the planets. But

as this important element in the calculation is still a desideratum, we must resort to other methods by which we may arrive at the nearest approximation to the truth.

I have already alluded to the photometrical experiments of Dr. Wollaston, in relation to the comparative quantity of light emitted to our eye from the star Sirius and from the sun. In reference to these experiments, Sir John Herschel, in a marginal note, remarks:—“Dr. Wollaston assuming, as we think he is perfectly justified in doing, a much lower limit of possible parallax in Sirius than we have adopted in the text, has concluded the *extrinsic light of Sirius to be nearly that of FOURTEEN SUNS.*” Sir William Herschel informs us that, with a magnifying power of 6450, and by means of his new micro-meter, he found the apparent diameter of *Vega* or  $\alpha$  Lyrae to be  $0''.555$ : this will give the real diameter of the star about *thirty-eight* times that of the sun, or 35,413,000 miles, supposing its parallax to be one second. Were this its true estimate its solid contents would be 19,579,357,557,382,430,000,000, \* or, above nineteen thousand five hundred and seventy-nine trillions of miles; which is, *fifty-four thousand eight hundred and seventy-two times* larger than the solid contents of the sun. The magnitude of such a globe is altogether overpowering to the human imagination, and completely baffles every effort to approximate to a distinct conception of an object of such amazing amplitude and splendor. We have formerly shown that the sun is a body of so vast dimensions that the human mind, in its present state, can form no adequate conceptions of it; that it is more than 500 times greater than all the planets, satellites, and comets of our system; that it is equal to thirteen hundred thousand globes as large as the earth; that its surface contains an amplitude fifty-three millions seven hundred and seventy thousand times larger than the view from Mount Etna, which comprises an extent of 45,000 miles; and that, were a landscape on the sun of this extent to be contemplated every two hours, it would require twenty-four thousand five hundred years before the whole surface of this luminary could be in this manner surveyed. What, then, shall we think of the probable existence of a luminous globe fifty-four thousand times greater than the expansive globe of the sun!

However amazing the magnitude of such a body may appear, we ought not on this account to consider the existence of such an orb as either improbable or incredible. Prior to the first discoveries of modern astronomy two or three centuries ago, no one could have believed that the sun is a body of such an immense size as he is now found to be, or that the planetary system occupies so extensive a range as astronomers have now determined it. And we are not to conceive that even the immense amplitude of the sun is the highest scale of magnitude which the Creator has prescribed to himself in his arrangements of the universe. From the knowledge we have already acquired of the vastness of the scale on which creation is constructed, we have reason

three minutes of the zenith. It is a star of about the fifth magnitude. It is 28 degrees nearly due east from the bright star *Vega* or  $\alpha$  Lyrae, in the constellation of the Harp, and nearly nine degrees south by east of *Dea*, or a *Cygni*, the principal star in the swan.

\* This star belongs to the constellation *Cygnus*, or the Swan. Its right ascension for January 1, 1839, was 20h. 53' 41", and its declination 37° 57' 42" north. In places of 52° of N. latitude, this star passes the meridian within two or

† In some editions of the “Improvements of Society,” this number is inaccurately stated, the cube of the diameter having been by mistake substituted for the solid contents of the body, but the general result of the comparative magnitudes of the two bodies is the same.

† “Celestial Scenery,” chap. iii, sect. 10

to believe that bodies exist in it far surpassing, in magnitude and grandeur, any of the globes to which we have alluded. There are certain lucid specks in the heavens which can only be perceived by the most powerful telescopes, which we are quite certain, from their immense distance, must comprise a mass of matter thousands of times larger than our sun,—either a distinct mass of materials or a congeries of shining globes so near each other that the separate bodies cannot be distinguished. As the distance between the great globes of the universe is incomprehensible by limited intellects, so the *magnitude* of some of these bodies may be so great as to surpass every estimate and every conception we may have hitherto formed on this subject. Such views of the magnitudes of creation are quite in accordance with the ideas we ought to entertain of a Being who is eternal, omnipresent, omnipotent, and incomprehensible.

But, without going beyond the strict deductions of science, we may fairly conclude that there are few stars in the concave of our sky that do not equal, and even surpass, our sun in size and in splendor; and if so, what a glorious and overwhelming scene does creation present to an intelligent and contemplative mind! Here we are presented with a scene on which the highest order of created beings may expatiate for myriads of ages, and objects, ever wonderful and ever new, may still present themselves to the astonished mind throughout the whole length of its immortality; so that the most expansive intellects shall never want subjects of sublime investigation during all the revolutions of an interminable existence.

We are not to imagine that all the stars, even those which appear with the same brilliancy, are of the same size. We have reason to believe that a *variety*, in this respect, exists among those distant orbs, as well as among the bodies which compose the planetary system, and in other departments of nature. Various considerations tend to show that “one star differeth from another star in glory,” not only as they appear to the naked eye, but in *reality*, as to their intrinsic magnitude and splendor. Some of the telescopic stars appear of very different colors, one exhibiting rays of an orange or ruddy hue, another blue, another yellow, and another green, indicating a difference in their constitution and in the nature of the light they emit. Among the double stars, the one which is found revolving round the other is evidently the smaller body, as its light is not distinguishable without a high magnifying power, and yet its distance from the earth must be nearly the same as that of the larger star around which it revolves. Recent observations tend to prove that some of the smaller stars have not only a greater annual parallax than those which are most brilliant, but an absolute motion in space much greater than those of the brightest class, which indicates that there is a difference in the real size of those bodies, and that some of the stars which appear smallest to our eye may be the largest in real dimensions; but the smallest of them are, undoubtedly, bodies of such magnitudes as surpass our distinct comprehension.

Some readers, from their ignorance of the mathematical principles of astronomy, and from being incapable of appreciating the observations to which we have referred, are apt to view with a certain degree of skepticism the conclusions which astronomers have deduced respecting the distances and magnitudes of the stars. Perhaps the following consideration, level to the capacity of every man of common sense, may have a tendency to convince even the most skeptical that

the stars are situated at an almost incalculable distance from the earth.

Suppose a telescope to magnify 400 times, that is, makes a distinct object appear four hundred times nearer, and four hundred times larger in diameter, than to the naked eye. With an instrument of this description I have been enabled to read a person's name, the letters of which were not above half an inch in length or breadth, at the distance of more than two miles. When this telescope is directed to the moon, it enables us to perceive the shadows of its mountains, and other minute portions of its scenery, and even to distinguish rocks and cavities less than a mile in diameter. When directed to the planet Venus, it exhibits it as a large splendid body, with either a gibbous, a half moon, or a crescent phase. When directed to Jupiter and Saturn, it makes these orbs appear several times larger than the moon does to the naked eye, and enables us to perceive the dark belts which run across the one, and the rings which surround the other. Now, if this same instrument be directed to the fixed stars, it shows them only as so many luminous *points*, without any well-defined diameters. It brings to view hundreds and thousands of stars which the naked eye cannot discern; but although they appear somewhat more brilliant, they appear, on the whole, no larger in diameter than the stars in general do to the unassisted sight. This circumstance I consider as a palpable and *sensible* evidence of the immense distance of the fixed stars; for bodies at the distance of nine hundred, and even of eighteen hundred millions of miles, appear magnified in proportion to the power of the instrument; and why should not the fixed stars appear magnified in the same proportion, and present to the eye large discs like the planets, were it not on account of their incalculable distance? Were they only at a moderate distance from the planetary system—suppose ten times the distance of Saturn, or nine thousand millions of miles,—this would undoubtedly be the case; but observation proves the contrary. When we view a planet—for example *Saturn*, which is distant nine hundred millions of miles—through a telescope magnifying 400 times, we contemplate it as if we had been carried to a point only the four-hundredth part of its distance; that is, we view it as if we were brought within little more than *two millions* of miles of its surface. In other words, we see it of the same magnitude, and nearly with the same distinctness, as if he had surmounted the law of gravitation, and been transported more than 897 millions of miles from our present abode in the direction of that orb.

When such an instrument is directed to the fixed stars, it does not lose its power as a telescope; this is proved by its presenting the *nebule*, which are invisible to the naked eye, as large, well-defined spaces in the firmament. It carries us within the four-hundredth part of their actual distance, and enables us to contemplate them just as we would do if we were 400 times nearer them than we are. Let us suppose, as formerly, the distance of the nearest stars to be 20,000,000,000,000, or twenty billions of miles, we contemplate such stars by this instrument, as if we were carried to a station nineteen billions nine hundred and fifty millions of miles from the place we now occupy, where we should still be fifty thousand millions of miles?

\* The following is the calculation expressed in figures:  
 400) 20,000,000,000,000, dist. of the star.  
     50,000,000,000, as viewed by the telescope.  
 19,950,000,000,000, dist. from the earth at which we view it

distant from these bodies. Supposing the sun were removed to a point fifty thousand millions of miles from the place he now occupies—which is 526 times his present distance,—he would appear 526 times less in diameter than at present, or under an angle of little more than  $3\frac{1}{2}$  seconds, which is less than the apparent diameter of Uranus, a body which is generally invisible to the naked eye; so that if a star be distant twenty billions of miles, and equal to the sun in magnitude, it should appear no more than a point when viewed with a telescope magnifying 400 times. Supposing, then, that we were transported through the immense space of 19,950,-

000,000,000 miles, we behoved to be carried forward several thousand millions of miles farther before those distant orbs would appear to expand into large discs like the moon, or like Jupiter and Saturn, when viewed through telescopes.

The above considerations prove to a demonstration that the nearest stars are removed from us at immense and inconceivable distances; and if their distance be so great, their *magnitudes* must likewise be astonishing, otherwise they would be altogether invisible either to the naked eye or by the telescope; for a distant visible object must always be considered as having a magnitude proportional to its distance and its *apparent diameter*

## CHAPTER VI.

### ON NEW STARS.

To almost every eye but that of the astronomer, the starry firmament presents the same general aspect. To a common observer, the nocturnal heavens exhibit the appearance of a vast concave spangled with countless numbers of shining points, of various degrees of brilliancy, and distributed over the sky apparently without any order or arrangement.—Whether the clusters of stars which are seen in summer and in winter are the same,—whether the stars which are seen in one region of the heavens at six o'clock in the evening are identically the same which are seen in the same quarter at midnight, or at three in the morning,—whether there be any stars which were seen by our forefathers which are no longer visible,—whether any stars unknown to former generations can now be traced in the firmament,—or whether any of those orbs which are visible at one time are invisible at another,—to such inquiries there is not one out of a thousand of those who have occasionally gazed at the starry heavens that could give a satisfactory reply. It is the industrious astronomer alone, who, with unwearied observations spends sleepless nights in surveying the various regions of the celestial vault, that can tell with certainty whether or not any changes occasionally take place in reference to any of the starry orbs.

The first account we have of any changes having been perceived among the stars is that recorded by Hipparchus, of Rhodes, a celebrated astronomer who flourished about 120 years before the Christian era. About this period, this accurate observer of the heavens perceived, in a certain part of the firmament, a star which he had never observed before, and of which he could find no record in the observations of his predecessors. Struck with this new and unexpected phenomenon, he began to doubt whether changes might not happen among the celestial orbs, as well as in the scene of nature here below. In order that such changes when they happen might be known to future generations, he began to form a catalogue of all the stars visible in that part of the world where he resided, noting down the place and apparent magnitude of each star, until he at length completed a list of all the visible stars in the heavens; which was the first catalogue of those luminaries of which we have any account in history. It is much to be regretted that we have no specific account of the particular part of the heavens where this new star appeared, as it might have led us to determine whether it be still visible, or whether it be subject

to periodical changes, or have altogether disappeared.

In the year 130 after the Christian era, another new star is said to have made its appearance. In the year 389, a new star appeared near  $\alpha$  Aquila, or Altair, in the constellation of the Eagle. Its appearance was sudden; it continued three weeks, emitting a splendor equal to that of Venus, and afterward entirely disappeared. In the ninth century, a new star appeared in the fifteenth degree of Scorpio, which is said to have emitted as much light as is reflected from one quarter of the moon. In 945, a new star appeared between the constellations of Cepheus and Cassiopeia; and another, in 1264, near the constellation Cassiopeia; but of these stars the accounts are so vague and imperfect that we can form no distinct conceptions of the phenomena they exhibited.

The most striking and wonderful phenomenon of this kind of which we have an authentic and distinct description occurred in the beginning of November, 1572, when a new star appeared in Cassiopeia, forming nearly a rhombus with the three largest stars,  $\alpha$ ,  $\beta$ ,  $\gamma$ , of that constellation. Its appearance was sudden and brilliant. Its phenomena were so striking that the sight of it determined the celebrated Tycho Brahe to become an astronomer. He did not see it at half an hour past five, when he was returning from his house to his laboratory; but returning about ten, he came to a crowd of country people who were staring at something behind him. Looking round, he saw this wonderful object. It was so bright that his staff had a shadow; it was of a dazzling white, with a little of a bluish tinge. It had no tail or hair around it similar to comets, but shone with the same kind of luster as the other fixed stars. Its brilliancy was so great as to surpass that of *Lyra* and *Sirius*. It appeared even larger than Jupiter, which was then at its nearest approach to the earth, and by some was estimated to be superior to the planet Venus in its greatest luster. It was even seen by those who had good eyes at noonday; a circumstance which never happens in the case of any of the other stars, or even of the planets, except Venus, which has sometimes been seen in daylight in certain peculiar positions. During night, it was frequently seen through thin clouds which entirely intercepted the light of the other stars. In this state it continued to shine with undiminished brilliancy during the remaining part of November, or more than three weeks. It did not, however, continue

much longer with this degree of brightness, but gradually diminished in its luster. In the month of December, it appeared to be only equal to Jupiter; in January, 1573, it appeared a little less than that planet, but still somewhat larger than stars of the first magnitude, to which it appeared about equal during the months of February and March; thus gradually diminishing in brightness, in April and May, it was like a star of the second magnitude; in the mouths of June, July, and August, it was equal only to the largest stars in Cassiopeia, which are mostly of the third magnitude; in September, October, and November, it was no larger than a star of the fourth magnitude; in December, it was about equal to the star called *Gamma*, which was nearest to it; toward the end of 1573, and during the month of January, 1574, it was but little superior to stars of the fifth magnitude; in February, it was no larger than a star of the sixth magnitude; and in the month of March it entirely disappeared, having continued visible from the beginning of November, 1572, to March, 1574, a period of about sixteen months. It was remarked that as it diminished in size it was likewise subject to certain changes in color and brightness. When it appeared largest, its light was *white* and brilliant; after which it appeared a little *yellowish*; and in the beginning of spring, 1573, it approached something to the color of Mars, being reddish like the star *Aldebaran*, or the Bull's Eye, and a little less bright than the star in the right shoulder of *Orion*. In the month of May that year, it was of a pale livid white, like Saturn; which color, as likewise its sparkling appearance, continued to the last, only growing more dim and faint as it approached the period of its disappearance.

Such were the appearances and changes of this wonderful star. These phenomena were particularly observed by several astronomers of that period, especially by Tycho Brahe, who wrote a treatise on the subject, in which he determined its longitude and latitude, and demonstrated that it was situated in the region of the fixed stars, at a much greater distance from the earth than the sun, moon, or any of the planets, as it had no sensible parallax, and remained in the same point of the heavens during the whole period of its appearance. This star was likewise diligently observed by Cornelius Gamma, who says that on the night of the 8th November, 1572, he viewed with some attention that part of the heavens, in a very serene sky, but saw nothing uncommon; but that the next night, November 9th, it appeared with a splendor surpassing all the fixed stars, and scarcely less bright than Venus. The longitude of this star, as determined by Tycho, was  $90^{\circ} 17'$ , and  $53^{\circ} 45'$  of north latitude.

The point in the heavens where this star appeared may be ascertained from the following figure, which exhibits a representation of the principal stars in Cassiopeia. The general position of this constellation may be found from the map of the circumpolar stars, Plate III. It is almost directly opposite *Ursa Major*, or the Great Bear. A line drawn from the Bear through the pole-star meets Cassiopeia at nearly an equal distance on the other side of that star. When the Bear is at its lowest position below the pole, Cassiopeia is near the zenith, and *vice versa*. In the annexed representation (fig. 9) the large star toward the left points out the place which was occupied by the new star, which, with the three stars,  $\alpha$ ,  $\beta$ ,  $\gamma$ , forms a kind of rhombus, or irregular square. The one on the left above the new star is  $\beta$ , and is also known by the name of *Caph*.

The one to the right of *Caph* and a little higher is  $\alpha$ , distinguished likewise by the name *Schedir*. Below *Schedir*, and a little to the right, is the star  $\gamma$ , or *Gamma*. About six degrees north-west of

Fig. 9.

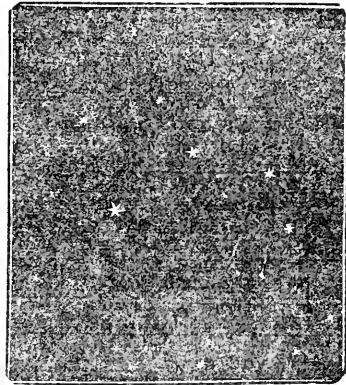

*Caph*, the telescope reveals to us a pretty large nebula of small stars, apparently compressed into one mass, with a number of loose stars surrounding it.

In the year 1604, about the end of September, another new star appeared near the heel of the right foot of *Serpentarius*. At that time, near the same part of the heavens, the planets Mars, Jupiter, and Saturn, were very near to each other, a phenomenon which so engaged the attention of astronomers that no uncommon appearance in that quarter of the heavens could long have escaped detection. On the 17th of September, Kepler, who wrote a treatise on this star, carefully observed the three planets; on the 23d, he again viewed Mars and Jupiter, then approaching to their conjunction; and one of his scholars made the same observation on the 27th. On the 28th, and on the 29th, which was the day when Mars and Jupiter were in conjunction, they were observed by *Mästlinus* and others; but none of them as yet saw anything of the new star. On the 30th, the sudden breaking of the clouds afforded one of Kepler's friends an opportunity of having a very short view of it: for in looking for Mars and Jupiter, he saw a bright star near them, which he had not seen before, but it was soon obscured by clouds. On the 2d, 3d, 4th, and 6th of October, it was seen by several persons in different places. On account of cloudy weather at Prague, where Kepler resided, he did not see it until the 8th of that month. All the observers agreed in this,—that it was exactly round, without any beard or tail; that it was exactly like one of the fixed stars; and that in the vividness of its luster, and the quickness of its sparkling, it exceeded anything they had ever seen before. As to its color, it was remarked that it was every moment changing into the colors of the rainbow, as yellow, orange, purple, and red; but was generally white when at a little height above the vapors near the horizon. At its first appearance, it seemed larger than any of the fixed stars, and even surpassed Jupiter, which planet was near it during the whole of October, and by its steady light was easily distinguishable from this vehemently sparkling star. It continued of the same size and brilliancy during the whole of October. About the end of this month the sun was approaching that part of the heavens in which the

star appeared, yet on the 30th it was so much brighter than Jupiter that Kepler could see it distinctly when Jupiter was imperceptible, on account of the light of the sun, though he was farther from the sun's beams than the star. On the 6th and 8th of November it was seen by Kepler and others; and at Turin, on the 13th, which appears to have been the last time it was perceived before being overpowered by the solar rays. After emerging from the sun's rays, on the west, it was seen in the morning on the 24th December, and though it sparkled exceedingly, yet it was considerably diminished in magnitude, appearing however, larger than the bright star *Antares*. From the middle of January 1605, until the middle of March, it gradually diminished in brightness. In the beginning of April, it appeared like a star of the third magnitude, and continued nearly of the same size during the months of May, June, and July, and continued to sparkle more strongly than any other fixed star. On September 28th, a year after its first appearance, it was more brilliant than the star in the leg of *Serpentarius*, which is reckoned of the third magnitude. As it was at this time again approaching to the vicinity of the sun, it does not appear to have been seen after this period. In December, 1605, and January, 1606, cloudy weather prevented observations after it had emerged from the solar rays. Kepler concludes that it must have disappeared some time between October, 1605, and the following February, but on what day is uncertain. Like the former star which appeared in *Cassiopeia*, it had no parallax, and remained in the same point of the heavens.

None of the new stars whose phenomena we have described above have ever reappeared, the places which they occupied still remaining a blank. It is much to be regretted that the telescope was not invented at the periods when these stars appeared, as it might have been ascertained by their instrument whether they had any sensible diameters. At any rate, their gradual decrease of magnitude and luster might have been traced by a good telescope for a long period, perhaps for years, after they disappeared to the naked eye, which must have led us to draw some conclusions respecting the cause which produced so extraordinary phenomena. Were such a remarkable phenomenon to happen in our times, when telescopes, microscopes, and other astronomical instruments have received so many exquisite improvements, so as to enable us to penetrate deep into the profundity of space, and to measure the smallest angles, a variety of additional facts and circumstances would doubtless be discovered in relation to phenomena and events so striking and sublime.\*

The subject of new stars, such as those now described, which blazed forth with so extraordinary a brilliancy and so soon disappeared, naturally gives rise to solemn and interesting reflections. There is a mystery that hangs over such sublime phenomena which produces in the mind an anxious desire to behold the veil removed, and to investigate the reasons and causes of such stupendous events. "It is impossible," says Mrs. Somerville, when alluding to the star of 1572,

\* Beside the above, the following instances of new stars may be noted:—In the year 1670, a new star was discovered by Hevelius and Anthelm, near the head of the *Swan*, which, after becoming invisible, reappeared, and after undergoing several singular fluctuations of light during two years, gradually vanished from the sight, and has never since been seen. Another new star is said to have been seen the same year at Paris, about the back of the *Swan*, which, after the space of fourteen days, vanished away.—Whiston's *Astronomical Lectures*, p. 45.

"to imagine anything more tremendous than a conflagration that would be visible at such a distance." Whether there was anything in the existing state of the body alluded to similar to what we call a *conflagration* may be justly doubted, but there was a splendor and luminosity concentrated in that point of the heavens where the star appeared which would more than equal the blaze of *twelve hundred thousand worlds* such as ours, were they all collected into one mass, and all at once wrapt in flames. Nay, it is not improbable that were a globe as large as would fill the whole circumference of the earth's annual orbit to be lighted up with a splendor similar to that of the sun, it would scarcely surpass in brilliancy and splendor the star to which we refer; for during the whole period of its continuing visible, it never appeared in the least to shift its position, though it was carefully watched by the astronomers of that age; and, consequently, the whole diameter of the earth's orbit, while the earth passed from one extremity of it to another, appeared only as a point at the vast distance at which the star was situated. These may appear bold positions, but they are in some measure warranted by the facts of the case, and they are perfectly consistent with what we know of many of the other astonishing operations of that Almighty Being who is "wonderful in counsel and excellent in working," and "whose ways," in providence and creation "are past finding out."

It is natural to inquire what may have been the cause of phenomena so extraordinary and sublime; but our limited views of creation and of the plans and purposes of its Omnipotent Contriver and Governor prevent us from arriving at any satisfactory conclusions. La Place says in reference to this subject—"As to those stars which suddenly shine forth with a very vivid light, and then vanish, it may be supposed, with probability, that great conflagrations, occasioned by extraordinary causes, take place on their surfaces; and this supposition is confirmed by their change of color, analogous to that which is presented to us on the earth by bodies which are consumed by fire."\* But such an opinion, however great the astronomer who proposed it, appears quite unsatisfactory. We err egregiously when we attempt to compare the puny operations and conflagrations which happen on our globe with a scene so far transcending everything we behold in this terrestrial sphere. The greatest conflagration that was ever witnessed on earth cannot bear the smallest proportion or similitude to an object which must have occupied a space more than ten hundred thousand times the solid contents of our globe; nor is it likely that the agents or elementary principles which produced the respective phenomena were at all similar.

The late Professor Vince, one of the most learned astronomers of his age, has the following remark:—"The disappearance of some stars may be the destruction of that system at the time appointed by the Deity for the probation of its inhabitants, and the appearance of new stars may be the formation of new systems for new races of beings then called into existence to adore the works of their Creator."† The late Dr. Mason Good seemed to indulge in a similar opinion "Worlds, and systems of worlds," says he, "are not only perpetually creating, but also perpetually disappearing. It is an extraordinary fact that, within the period of the last century, not less than

\* *System of the World*, vol. 1, p. 101.

† Vince's "Complete System of Astronomy,"

thirteen stars, in different constellations, seem to have totally perished, and ten new ones to have been created. In many instances it is unquestionable that the stars themselves, the supposed habitation of other kinds or orders of intelligent beings, together with the different planets by which it is probable they were surrounded, have utterly vanished, and the spots which they occupied in the heavens have become blanks. What has befallen other systems will assuredly befall our own. Of the time and the manner we know nothing; but the fact is incontrovertible—it is foretold by revelation—it is inscribed in the heavens—it is felt through the earth. Such is the awful and daily text; what, then, ought to be the comment?" Similar to these were the sentiments of the late Professor Robinson, of Edinburgh:—"What has become of that dazzling star, surpassing Venus in brightness, which shone out all at once in November, 1572?"—"Such appearances in the heavens make it evident that, notwithstanding the wise provision made for maintaining that order and utility which we behold in our system, the day may come 'when the heavens shall pass away like a scroll that is folded up, when the stars in heaven shall fall, and the sun shall cease to give his light.' The sustaining hand of God is still necessary, and the present order and harmony which he has enabled us to understand and admire is wholly dependent on his will, and its duration is one of the unsearchable measures of his providence."

Such are the pious sentiments of the above-named respectable philosophers in reference to the subject under consideration; but it may be questioned whether they are altogether judicious, or correspondent to the perfections of the Creator and the arrangements he has made in the universe. They seem to take for granted that those stars which have blazed for awhile, and then disappeared, have been destroyed or annihilated. We are indeed informed that, in regard to our globe, a period is approaching when "the elements shall melt with fervent heat, and the earth and the works that are therein shall be burnt up." But such a conflagration cannot be justly compared to the splendor of those wonderful stars described above. At whatever period in the lapse of duration such an event may take place, it will be so far from being visible at the nearest star, that it would not be seen by such eyes as ours at the boundaries of our system. Beside, we are assured, in that revelation which announces it, that that awful event shall take place as one of the consequences of the sin and depravity of man; and therefore we have no reason to believe that it will extend to the sun or any of the surrounding planets of our system; nor have we any reason to conclude that the conflagration of our globe will issue in its entire destruction, or that the elementary principles of which it is composed will be annihilated. It is more probable, nay, almost certain, that this tremendous event will only tend to purify our globe from the physical evils which now exist, and to transform it into a new and happier world for the residence of renovated and pure intelligences. In regard to *annihilation*, we have no proof that any particle of matter which was ever created has yet been annihilated.\* Incessant changes and transformations are going forward both in the scene of sublunary nature and throughout the celestial regions; but changes in material objects do not necessarily imply the

destruction of the matter of which they are composed, but simply a new arrangement or mode of operation. We have no reason to believe that any portions of matter which now exist throughout the universe will ever be reduced to annihilation. On the other hand, we have palpable evidence, from several phenomena in the heavens, that the work of creation is still going forward, and that the Creator is gradually ushering into existence new suns, and systems, and worlds; and in all probability his creating energy will be continually exerting itself throughout all the succeeding ages of eternity.

Again, if that grand and terrific event which is to put a final period to the present terrestrial system is to be viewed as a consequence of the introduction of moral evil and the depravity of man, then we are led to conclude that those intelligences which were connected with the systems which are supposed to have been destroyed must have been involved in the guilt of moral degeneracy, or, in other words, in rebellion against their Creator; otherwise, why were they subjected to such an awful catastrophe, and doomed to be blotted out of existence? We have no ground for entertaining any such supposition. Reasoning from the *benevolence* of the Deity, it is more probable to conclude that the inhabitants of our world are almost the only intelligences throughout the universe who have swerved from the path of original rectitude, and violated the moral laws of their Maker. Nor is it likely that the *whole inhabitants* of any system, consisting, perhaps, of thirty or even of a hundred worlds—would be found uniting in rebellion against the moral government of their Benefactor, so as to warrant the *entire* destruction of the system with which they were connected. Beside, were the views of the philosophers to which I allude to be adopted, then we must admit that the systems which in their opinion were destroyed or annihilated must have been continued in existence only for a year or two; for no luminous bodies occupied the places of the new stars before they burst on a sudden to the view, and no twinkling orbs have been seen in these points of the heavens since they disappeared; but it is surely not at all probable that the Almighty would launch into existence systems of such amazing magnitude and splendor, and suffer them to rush into destruction within a period of so very limited duration.

For the reasons now stated, and others which might have been brought forward, I cannot acquiesce in the views of the respectable philosophers to which I have adverted; but it is easier to set aside an untenable hypothesis than to attempt an explanation of the real causes of so sublime and wonderful phenomena. In investigating the distant wonders of the universe and the arrangements of the Divine government, it becomes us to express our sentiments with modesty and caution. Whatever may have been the causes which produced the sudden splendor and the rapid disappearance of the new stars, I entertain not the least doubt that those bodies are still in existence, and subserving important purposes in the economy of God's universal government. Almost any hypothesis is to be preferred to that which supposes their destruction or annihilation. What should hinder us from concluding that the extraordinary phenomena of the star of 1572 was owing to a luminous orb of immense magnitude, accompanied with a retinue of worlds, *moving with inconceivable velocity in an immense elliptical orbit, the longer side of which was nearly in a direction to our eye; that its most brilliant appearance was*

\* See "Philosophy of a Future State," chap. i, sect. 10; and "Christian Philosopher."

when it was nearest our system, as at *A*, (fig. 10), supposing *E* the relative position of the earth, or of our system; and that, as it gradually declined in its brightness, it was passing along the curve from *A* toward *B* and *C*, until its rapid flight at

Fig. 10.

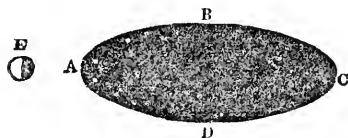

length carried it beyond the limits of human vision? Had telescopes been in use at that period, there is little doubt it would have been seen, though still diminishing, for a much longer period than that in which it was visible to the unassisted eye; in which case it would have fully corroborated the opinion now stated. In confirmation of this explanation of the phenomena it has been supposed, with a high degree of probability, that it is the same star which appeared in the year 945 and in 1264, which, of course, would have a period of revolution of about 319 years, which period might vary two or three years in the course of its revolutions, from causes with which we are unacquainted, as we find sometimes happens in the case of comets. This opinion is rendered the more probable from the consideration that the stars of 945 and 1264 appeared in the constellation of *Cassiopeia*, where likewise the star of 1572 was observed; and if these be identical, then it is probable that it will again make its appearance about the year 1891 or 1892; and if so, astronomers will then have a better opportunity of marking its aspects and motions, and determining its size and its period of revolution.

If this explanation appear the most probable, it presents to the mind a most magnificent and overwhelming idea, without supposing anything so tremendous and terrific as a sudden conflagration. It presents before us a luminous globe of astonishing magnitude—perhaps not less than a hundred times the size of our sun—winging its course over a circuit perhaps a thousand times more expansive than the orbit of Uranus, and carrying along with it a hundred worlds in its swift career. The motion of such a body must have been rapid in the extreme, when we consider the rapid diminution of its apparent magnitude. In the month of November it first appeared; in December its brightness was sensibly diminished; in the month of April following it had diminished to the size of a star of the second magnitude; in July, to one of the third magnitude; in October, to one of the fourth; in the following January, to one

of the fifth; in February, to one of the sixth magnitude; and in March it disappeared.

Now, according to Sir W. Herschel's experiments, the light of a star of the first magnitude being supposed 100, the light of one of the second magnitude is 25, one of the third magnitude, 12, &c. (see p. 22). If, then, we suppose these classes of stars to be nearly of equal magnitudes, and that their distance is in an inverse proportion to the diminution of their light, it will follow that a star of the second magnitude is four times the distance of a star of the first; a star of the third magnitude, four times the distance of the second, or eight times the distance of the first magnitude, &c. Supposing, then, the star of 1572 to have been twenty billions of miles from the earth at its nearest approach to our system; from December, 1572, to April, 1573, when it was diminished to the apparent size of a star of the second magnitude, it must have moved four times that distance, or eighty billions of miles during these four months, which is at the rate of six hundred thousand millions of miles a day, and four hundred and sixty-two millions a minute, a velocity of which we can have no adequate conception.

If the above explanation be unsatisfactory, I know not to what hypothesis to resort for a solution of this mysterious and wonderful phenomenon. Whatever view we may be disposed to take of such striking events, we are lost in admiration and wonder. We behold a display of magnitude, of motion, and of magnificence, which overpowers the human faculties, which shows us the littleness of man and the limited nature of his powers, and which ought to inspire us with reverence of that Almighty Being who sits on the throne of the universe, directing all its movements for the accomplishment of his wise and righteous designs, and for the diffusion of universal happiness throughout all the ranks of intelligent existence. However astonishing the conclusions we are led to deduce from the phenomena under consideration, the facts to which we have adverted are not beyond the energies of Him whose perfections are strictly infinite. Nay, from such a Being, who is self-existent and omniscient, who fills the immensity of space with his presence, and whose power is boundless in its operation, we should naturally expect that displays of creating and sustaining energy would be exhibited, altogether overwhelming and incomprehensible by mortals. "Canst thou by searching find out God? Canst thou find out the almighty to perfection? In the heights of heaven he doth great things past finding out, yea, and wonders without number. By his spirit he hath garnished the heavens. The pillars of heaven tremble and are astonished at his reproof. Lo, these are but parts of his ways; but the thunder of his power who can understand?"



## CHAPTER VII.

### ON VARIABLE SIGNS.

WHEN the starry firmament is attentively surveyed, and the aspects of the numerous orbs it contains particularly marked, it is found that several of these bodies are subject to periodical changes in the brilliancy of their light and their apparent diameters, indicating in some instances motions and revolutions of considerable extent. The following sketches contain descriptions of the more remarkable phenomena connected with this class of the heavenly bodies, generally known by the name of *variable*, or *periodical* stars:

The first star of this kind which seems to have been particularly noticed is one in the neck of the Whale, whose right ascension is 2h. 5' 33", and south declination, 3° 57' 25". It was first observed on August 13th, 1596, by David Fabricius, when it appeared like a star of the third magnitude, but disappeared after the month of October in the same year. It was again observed by Holwarda in the year 1637; and after having disappeared during a period of nine months, it again became visible; since which time it has been found every year pretty regular in its period, except from October, 1672, to December, 1676, during which time Hevelius could not perceive it, though it was a particular object of his attention. Bullialdus, a Frenchman, having compared together the observations that had been made on it from 1638 to 1666, determined the periodical time between its appearing in its greatest brightness and returning to it again to be 333 days. He found also that about 120 days elapse between the time that it is first seen of the sixth magnitude and its disappearing; that it continues in its greatest luster for about fifteen days; that after its first reappearance of the sixth magnitude it increases in size much faster until it comes to be of the fourth magnitude, than it does from that period to its being of the third; and that from its being of the third it increases to the second magnitude by still slower degrees. Modern astronomers give the following description:—"It remains in its greatest brightness about a fortnight, being then nearly equal to a star of the second magnitude; it decreases during three months, until it becomes completely invisible, in which state it remains about five months, when it again becomes visible, and continues increasing during the remaining three months of its period; but it does not always return to the same degree of brightness, nor increase and diminish by the same gradations." It appears about twelve times in eleven years. Cassini determined its period to be 334 days; but Sir W. Herschel makes it 331 days, 10 hours, 19 minutes. It appears, then, that this star passes through all the gradations of light and magnitude from a star of the second to a star of the sixth magnitude and under; but after it has disappeared to the naked eye it may be traced to its lowest magnitude by a telescope of moderate power. It is sometimes distinguished by the name of *Stella Mira*, or the wonderful star, and *Omicron Ceti*.

In 1704, Maraldi observed a variable star in the constellation *Hydra*. This star had been described by Montanari in 1670, but was not visible

in April, 1702. Maraldi saw it for the first time in the beginning of March, 1704, in the same place where it had been seen thirty-four years before. It appeared of the fourth magnitude, and continued nearly in the same state until the beginning of April. It then gradually diminished until the end of May, when it could no longer be seen by the naked eye, but was visible through the telescope for a month longer. It could not be seen again until the end of November, 1705, when that part of the heavens began to emerge from the sun's rays. It was then very faint, and grew less and less until the end of February, 1706, and could then be scarcely perceived even with a telescope. It did not reappear until the 18th of April, 1708, when it was larger than a star of the sixth magnitude, and increasing in luster. It was seen by the same observer afterward, in the years 1709 and 1712. From the observations of Maraldi, Mr. Pigot concludes that its period was then 494 days; but from observations made by himself he thinks that *now* it is only 457 days; so that from the time of Maraldi it has shortened seven days. The following are the more prominent particulars relating to this star:—1. When at its full brightness it is of the fourth magnitude, and does not perceptibly change for the space of fourteen days. 2. It is about six months in increasing from the tenth magnitude and returning to the same; so that it may be considered as invisible during that time. 3. It is considerably more quick, perhaps one-half more so, in its increase than in its decrease. 4. Though, when at its full, it may always be styled a star of the fourth magnitude, it does not constantly attain the same degree of brightness, but the differences are very small. 5. Its right ascension for 1706 is 31h. 18' 4"; and its south declination, 22° 9' 35". It is marked No. 30 in Hevelius' Catalogue of the Stars; from which data, its place may easily be found on a planisphere, or on the celestial globe.

In the year 1600, G. Janssonius discovered a variable star in the breast of the Swan, which was afterward observed by different astronomers, and supposed to have a period of about ten years. The results of Mr. Pigot's calculations from the observations of former astronomers are—1. That it continues in full luster for five years. 2. It decreases rapidly for two years. 3. It is invisible to the naked eye for four years. 4. It increases slowly during seven years. 5. All these changes are completed in eighteen years. 6. It was at its minimum at the end of the year 1663. 7. It does not always increase to the same degree of brightness, being sometimes of the third, and at others only of the sixth magnitude. "I am entirely ignorant," says Mr. Pigot, "whether it is subject to the same changes in this century, having not met with any series of observations upon it; but if the above conjectures are right, it will be at its minimum in a very few years. Since November, 1781, to the year 1786, I have constantly seen it of the sixth magnitude, though I suspect that in 1785-6, it had rather decreased." This star is

near *Gamma* in the Swan's breast; it varies from the third to the sixth, seventh, &c. magnitudes. Its right ascension is 20h. 9' 54"; north declination, 37° 22' 37".

One of the most remarkable of these changeable stars is that called *Algol*, in the head of *Medusa*, in the constellation *Perseus*. It had long since been known to appear of different magnitudes at different times; but its period was first ascertained by John Goodricke, Esq. of York, who began to observe it in the beginning of the year 1783. It changes continually from the first or second to the fourth magnitude; and the time which elapses from one greatest diminution to the other was found in 1783 to be, at a mean, 2 days, 20 hours, 49 minutes. The change is thus—during four hours it gradually diminishes in luster; during the succeeding four hours it recovers its first magnitude by a like gradual increase; and during the remaining part of the period, namely, 2 days, 12 hours, 42 minutes, it invariably preserves its greatest luster; after the expiration of which its diminution again commences. According to Mr. Pigot, who has made many observations on such stars, and paid particular attention to the subject, the degree of brightness of this star when at its *minimum* is variable at different periods; and he is of the same opinion in regard to its brightness when at its full; but whether these differences return regularly or not has not been determined. The right ascension of *Algol*, or  $\beta$  *Persei*, for 1786, is 2h. 54' 19"; and its north declination 40° 6' 58". It is situated 12° east of *Almaach*, in the foot of *Andromeda*, and may be known by means of three stars of the fourth magnitude lying a few degrees south-west of it, and forming a small triangle. It comes to the meridian on the 21st of December, about nine o'clock in the evening; but as it continues above the horizon at least twenty hours out of the twenty-four, it may be seen every evening from August to May.

Another variable star is to be found in the neck of the Swan. The period of this star has been settled by Maraldi and Cassini at 405 days; but from a mean of the observations of Mr. Pigot, it appears to be only 392, or at most 396.7-8 days. The particulars relating to it are,—1. When at its full brightness, it undergoes no perceptible change for a fortnight. 2. It is about three and a half months in increasing from the eleventh magnitude to its full brightness, and the same in decreasing; for which reason it may be considered as invisible during six months. 3. It does not always attain the same degree of luster, being sometimes of the 5th, and sometimes of the seventh magnitude. The right ascension of this star is 19h. 42' 21"; and its north declination, 32° 22' 58". It is situated in the neck, and nearly equidistant from *Beta* and *Gamma*, and south by west from *Dench*, at the distance of about twelve degrees, and is marked *Chi*.

The star *Eta Antinoi* is another star of this description, whose variation and period were discovered by Mr. Pigot in 1785. From his corrected observations, he concludes that it continues at its greatest brightness forty hours without decreasing; it is sixty-six hours after it begins to decrease before it comes to its full diminution; after which it continues stationary for thirty hours more; and then increases for thirty-six hours. In every period it seems to acquire its full brightness, and to be equally decreased. Its period therefore is seven days, four hours; and its greatest and least variation is from the third to the fifth magnitude. Its right ascension is 19h. 41' 34"; and its north declination 0° 28' 14". It is about

eight degrees south from *Allair*, the principal star in the constellation *Aquila*.

The above descriptions may suffice as specimens of the phenomena of variable stars. There are about seven or eight other stars which have been observed to be certainly variable, among which are the following:—A star in the Northern Crown, whose right ascension is 15h. 40' 11"; north declination, 28° 49' 30"; and period, 10 $\frac{1}{2}$  months. A star in *Hercules*, whose right ascension is 17h. 4' 54"; north declination, 14° 38'; and period of variation 60 $\frac{1}{4}$  days. A star in *Sobieski's* Shield, whose right ascension is 18h. 56' 38"; south declination, 5° 56'; and period 62 days. The star *Beta Lyrae*—right ascension, 18h. 42' 11"; north declination, 33° 7' 46"; greatest and least variation, 3, 4, 5; supposed period, 6 days, 9 hours. The star *Delta Cephei*, whose period is 5 days, 8 $\frac{1}{2}$  hours; right ascension, 22h. 21'; and north declination, 57° 50'. With several others.

Beside these, whose variations and periods have been determined, there are about thirty-seven other stars, which are, with good reason, suspected to be variable; but whose periods of change have not yet been ascertained, on account of the want of a sufficient number of observers, who might devote their attention more particularly to this department of astronomical observation. For example, the star *Pollux*, or *Beta Gemini*, is suspected to change from the first to the third magnitude.

When contemplating such changes among bodies so immensely distant, and of so vast magnitude, we are naturally led to inquire into the causes which produce these phenomena. Our ignorance, however, of the precise nature and constitution of those remote bodies, and of the scenes and circumstances in which they may be placed, prevent us from forming any definite or satisfactory conclusions. The following are some of the opinions which have been thrown out on this subject. It has been supposed that portions of the surfaces of these stars are covered with large black spots, which, during the diurnal rotation of the star, present themselves under various angles, and thus produce a gradual variation in its brilliancy. Sir W. Herschel says "Such a motion may be as evidently proved as the diurnal motion of the earth. Dark spots, or large portions of the surface less luminous than the rest, turned alternately in certain directions, either toward or from us, will account for all the phenomena of periodical changes in the luster of the stars so satisfactorily, that we certainly need not look for any other cause." Sir Isaac Newton thought that the sudden blaze of some stars may have been occasioned by the "falling of a comet into them, by which means they would be enabled to cast a prodigious light for a little time, after which they would gradually return to their former state." But we know too little about the nature of comets to be able to determine what effect they would produce in such a case, nor are we certain that such bodies are connected with other systems. If the fixed stars be nearly of the same nature as the sun, it is highly improbable that any such effect would be produced even although a comet were to fall into its luminous atmosphere, as that atmosphere appears to have nothing in it that would take fire by the approach of any extraneous body, or that would "blaze" like combustible substances on the earth. The blaze, if such an effect were to take place, would scarcely be distinguishable from our globe, and much less from a distant system. Maupertuis, in a "Dissertation on the Figures of the Celestial Bodies," is

of opinion that some stars, by their prodigious quick rotation on their axes, may not only assume the figures of oblate spheroids, but that, by the great centrifugal force arising from such rotations, they may become of the figures of millstones, or be reduced to flat circular planes, so thin as to be quite invisible when their edges are turned toward us, as Saturn's ring is in such positions. And when any eccentric planets or comets go round any fixed star, in orbits much inclined to its equator, the attraction of the planets or comets in their perihelions must alter the inclination of the axis of that star; on which account it will appear more or less large and luminous, as its broadside is turned more or less toward us. This opinion, at best, I consider as having a very small degree of probability, and almost quite untenable. Mr. Dunn, in a paper in vol. 52 of the "Philosophical Transactions," supposes that the interposition of some gross atmosphere may solve the phenomena under consideration. "The appearance of new stars," says he, "and the disappearance of others, possibly may be occasioned by the interposition of such an ethereal medium within their respective orbs as either admits light to pass freely or wholly absorbs it at certain times, while light is constantly pursuing its journey through the vast regions of space."

Whatever opinions we may adopt on this subject, it is evident that the regular succession of the variations of periodical stars preclude the idea of their being destroyed. It is likewise evident that motion of some kind or other, either in the stars themselves or in some bodies either directly or remotely connected with them, must be one of the causes of the phenomena in question; and it is not improbable that different causes in different instances may operate in producing the effects. It does not appear to me probable that the cause which produces the variation in the case of *Delta Cephei*, whose period is only 5 days, 8½ hours, is the same which produces all the variety of change which happens in the star *Gamma* in the Swan's breast, whose periodical changes are completed only in eighteen years. It is not unlikely that a rotation round an axis, which has the effect of presenting different sides of the star of more or less degrees of obscurity or brightness to the eye of a spectator, will account for the phenomena of such stars as *Eta Antioi* and *Delta Cephei*; but it does not appear probable that a motion of rotation is so slow in any of these bodies as to occupy a period of eighteen years, as in the case of the star in the breast of the Swan.

I am disposed to consider it as highly probable that the interposition of the opaque bodies of large planets revolving around such stars, may, in some cases, account for the phenomena. It is true that the planets connected with the solar system are so small in comparison of the sun that their interposition between that orb and a spectator at an immense distance would produce no sensible effect. But we have no reason to conclude that in all other systems the planets are formed in the same proportion to their central orbs as ours; but, from the variety we perceive in every part of nature both in heaven and earth, we have reason to conclude that every system of the universe is in some respect different from another. There is no improbability in admitting that the planets which revolve round some of the stars, may be so large as to bear a considerable proportion (perhaps one-half or one-third) to the diameters of the orbs around which they revolve; in which case, if the plane of their orbit lie nearly in the line of our vision, they would in certain

parts of their revolutions interpose between our eye and the stars, so as to hide for a time a portion of their surfaces from our view, while in that part of their orbits which is next the earth. Such a supposition is by no means inconsistent with the operation of the law of universal gravitation; for although such planets bore a considerable portion of the size of their central luminaries, yet we have only to suppose that their density is very small. They may be globes whose central parts are devoid of solid matter, consisting only of a solid external shell for the support of inhabitants, as is probably the case with the planet Saturn, whose density is only equal to that of cork.

A planet about the size we have now supposed revolving around a star would, in a great measure, account for the phenomena presented by *Algol*. This star accomplishes the period of its variations in 2 days and nearly 21 hours. During 3½ or 4 hours it gradually diminishes in luster, and during the succeeding four hours it gradually recovers its first magnitude. Throughout the remaining part of the period—namely, 2 days, 12 hours, 42 minutes,—it invariably preserves its greatest luster; so that the time of its being diminished in luster is only about the ninth part of its whole period of variation. Now supposing a planet about half the diameter of the star revolving around *Algol*, it would intercept a large portion of its surface when it passed between our eye and the star, as at *a, b* (fig. 11), where the white circular ring represents the surface of the star partly covered by the planet. Its luster would begin to

Fig. 11.

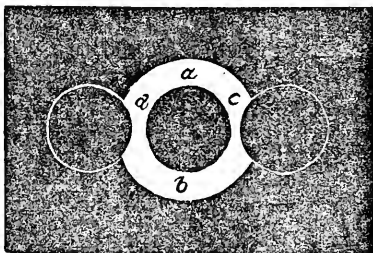

diminish when the planet entered on its edge at *d*, and it would again resume its full brightness when going off at *c*, the dark side of the planet being of course turned to our eye; and during the remaining part of its revolution it would appear in its brightest luster. The regularity of the changes of this star admits of the supposition now made, and evidently requires a regular motion of some kind or other, either in the star itself or in some body connected with it, in order to produce the phenomena. Perhaps, in the case of some of the variable stars, we might suppose several large planets in succession to pass between our eye and the star to account for the appearance they present—a supposition which perfectly agrees with the idea of a system of revolving bodies.

As it is not probable that the changes of all such stars arise from the same cause, what should hinder us from supposing that there are stars or suns that revolve around planets of a size immensely greater,—the planets, for example, bearing a similar proportion to the stars as the sun bears to Jupiter? Considering the immense variety of celestial mechanism throughout the universe, there can be no great improbability in such a supposition. The case of double stars demonstrates that

one sun actually revolves round another; and why may not a sun revolve around a central planet, whose surface may contain forty times the area of all the planets of our system, in order to distribute light and heat, and other beneficial influences, to its numerous population? No violation of the law of universal gravitation is implied in such a supposition; and the Almighty is not confined to one mode of arranging systems and worlds. Supposing, then, such an arrangement to exist, it might account for the phenomena of some of the variable stars, particularly those which remain invisible for a certain period. Such are some of those formerly noticed, as the star in Hydra, and that in the breast of the Swan, and particularly a star in the Northern Crown, whose right ascen. is  $15^{\circ} 40'$ , north declin.  $25^{\circ} 49' 12''$ , and period  $10\frac{1}{2}$  months, and which decreases from the sixth to the ninth and tenth magnitude. It attained its full brightness about the 11th of August, 1795, and continued so for three weeks; in  $3\frac{1}{2}$  weeks it decreased to the tenth magnitude, and a few days afterward disappeared. After being a considerable time invisible, in April, 1796, it again appeared; on the 7th of May, it reached the ninth magnitude, and then gradually attained its full brightness. If, then, such a star was revolving round a very large central planet, it is easy to conceive that in the more distant part of its course it might be hid from our view, either in whole or in part, by the interposition of the opaque central body, as is obvious from an inspection of figure 12. And as the star now alluded to never exceeds in luster a star of the sixth magnitude, it is not improbable that it is one of the inferior order of those luminous orbs which may revolve round an opaque body of superior magnitude.

Fig. 12.

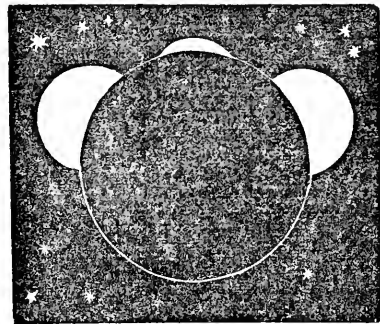

Such, then, are some of the conceivable causes which may produce the phenomena of variable stars, although other causes may in some cases exist of which we have no conception. These phenomena evidently indicate that motions and revolutions of various kinds are going forward throughout the stellar regions; that the Almighty is superintending the movements of those provinces of his empire, and that all his agencies have a respect to the order and the happiness of intelligent existence.

Beside the periodical variations to which we have now adverted, there are several other striking changes which have been observed in the starry regions which deserve our attention, and which I shall briefly notice.

1. Several stars which were formerly distinctly visible, and are marked in different catalogues, are now wholly lost. The following are a few instances. M. Montanere, professor of mathemat-

ics at Bononia, in a letter to the Royal Society, of date April 1670, gives the following statement:—"There are now wanting in the heavens two stars of the second magnitude, in the stern and yard of the ship Argo. I and others observed them in the year 1664, upon occasion of the comet that appeared that year. When they disappeared first I know not: only I am sure that, in the year 1668, upon the 10th of April, there was not the least glimpse of them to be seen, and yet the other stars about them, of the third and fourth magnitudes, remained the same. I have observed many more changes among the fixed stars, even to the number of a hundred, though none of them are so great as those I have showed." In 1670, Anthelm discovered a star of the third magnitude in the head of the Swan, which after becoming completely invisible, reappeared, and after undergoing one or two singular fluctuations of light during two years, at last died away entirely, and has not since been seen. Sir William Herschel gives a list of thirteen stars, most of which are supposed to be lost. Of these are the following:—Nos. 80 and 81 of Hercules, both of the fourth magnitude; the 19th of Perseus, of the sixth magnitude; and the 108 Pisces, are judged to be wholly lost. The stars 73, 74 Cancer, in the southern claw of the Crab, of the sixth magnitude, are either lost or have suffered such great changes that they can no longer be found. On this subject Sir John Herschel states—"The star 42 Virginis is inserted in the catalogue of the Astronomical Society from Zach's Zodiacal Catalogue. I missed it on the 9th of May, 1828, and have since repeatedly had its place in the field of view of my twenty feet reflector without perceiving it, unless it be one of two equal stars of the 9th magnitude very nearly in the place it must have occupied."

2. Some stars have changed their magnitudes since the beginning of last century. A considerable number of stars marked by Flamsteed, in his *Historia Cælestis*, are now found to be of different magnitudes since the period in which he observed the heavens and formed his catalogue. For example; the 1st and 2d of Hydra are now only of the eighth or ninth magnitude instead of the fourth, as they are marked by Flamsteed. The 31st and 34th of Draco have changed greatly; the 31st has increased from the seventh to the fourth, and the 34th has diminished from the fourth to the sixth or seventh magnitude. The 38th Perseus, instead of the sixth, has now increased to the fourth magnitude. About thirty stars of this description are reckoned by Sir W. Herschel to have changed their magnitudes.

3. There are stars unknown to the observers of former times which have recently become visible. The following, among others of this description, have been marked by Sir W. Herschel:—1. A star in the end of the Lizard's tail, of the fourth or fifth magnitude, which is not recorded by Flamsteed, although he notices one in that constellation less conspicuous. 2. A star near the head of Cepheus. 3. A considerable star in a direction from the 68th to the 61st of Gemini. 4. A star of considerable brightness preceding the 1st of the Little Horse. 5. A remarkable star between  $\beta$  and  $\epsilon$  Hydrae. 6. A star near  $\delta$  Hercules, of the fourth or fifth magnitude, with several others. Sir W. Herschel's observations appear to have been made about the end of the seventeenth and the beginning of the eighteenth centuries, by Cassini and others. Cassini discovered a new star of the fourth, and two of the fifth magnitude in Cassiopeia; two in the constellation Eridanus, one of the fourth the other of the fifth magnitude; and four of the fifth

and sixth magnitude near the north pole, which had not been perceived at a former period.

Such changes in bodies so far removed from our system, and of magnitudes so enormous as the rest of them must be, naturally lead to the conclusion that revolutions of vast extent, and operations conducted on a most magnificent scale, are incessantly going forward in those remote and unexplorable regions. In the case of stars which have totally disappeared, we are led to conclude, either that some vast and important change has taken place in the constitution of certain worlds or systems, or that the central luminaries of such systems, with all their surrounding planets, have been transported by some unknown and almighty agency into more distant regions of space, where they may remain forever hid from our view. As to those stars which have changed their magnitudes within the last century, they may either be approaching to or receding from the system to which we belong, or their native brightness may be either increasing or diminishing from causes with which we are unacquainted; or some ethereal mediums of a peculiar nature may be interposed between our sight and those distant orbs. With respect to stars unknown to former observers which have recently become visible, it is not unreasonable to suppose that these are *new systems* recently launched from the creating hand of the Omnipotent, to diversify his creation and augment the glories of his empire, as well as to distribute happiness among new orders of sensitive and intelligent existence. We ought not to imagine that the work of creation, considered as a whole, is yet finished, or ever will be finished during an indefinite lapse of ages. When it is stated by the inspired writer of the book of Genesis that "God rested from all his work," we are to understand the expression only in reference to the formation or arrangement of the world in which we reside into the form and order in which we now behold it; for to this arrangement chiefly, if not solely, the descriptions of the sacred historian in the first chapter of Genesis refer. It is in perfect accordance with the idea of a Being possessed of omnipotent power, boundless goodness, and endless duration, that his creating energies should never cease in their operation throughout all the periods of an interminable existence; and the phenomena to which we refer are a strong presumption, if not a demonstrative evidence, of a continued series of creations. These new creations may be bursting forth in the remote spaces of the universe, in various degrees of splendor and magnificence, to an extent of which we have no conception; and from the character and perfections of the Divinity, we have reason to believe that such processes will be incessantly going forward throughout all the ages of eternity.

Whatever opinions we may be disposed to form as to the phenomena to which we have adverted, they tend to convey to the reflecting mind magnificent views of the physical energies of the Almighty, in arranging the different departments of his boundless dominions, and accomplishing the purposes and plans of his moral government,

and they naturally excite in the mind a desire of future existence, and an ardent wish to behold the veil which now intercepts our views of these glorious orbs withdrawn, and to contemplate the scene of divine operation in all its splendor and magnificence.

At first view, it may appear a circumstance of comparative insignificance to behold a small star, scarcely distinguishable to the eye, waxing brighter, or growing dimmer, or vanishing altogether from the view; or a star appearing in a point of the heavens which was unoccupied before. The distant blaze of a field of furze, the falling of a tower, or the conflagration of a cottage, may to some appear events of far greater interest and importance; but such events in the heavens as those to which we refer may be connected with scenes as astonishing—though perhaps not so tremendous—as if the sun were shorn of his rays and turned into darkness, and this earth and all the planetary globes shattered to their centers and wrapped in flame; or, as if a new sun of superior magnitude were to appear in our system, and to illuminate our globes with a new species of light and colors. Objects at a great distance from the observer make little impression on the organs of vision, and seldom affect the mind. A fleet of the largest ships of war viewed from the top of a tower at fifty miles distance appears only like a few almost undistinguishable specks on the verge of the horizon, while the fate of individuals, families, communities, and even empires, may depend upon the encounter in which they may be engaged. The conflagration of a city of ten hundred thousands of inhabitants may appear at a distance as only a faint glimpse of light in one point of the horizon, while palaces, and temples, and thousands of splendid fabrics are turned into smoking ruins, and multitudes are thrown into the utmost consternation, and perishing in the flames. The burning of the city of Moscow, as beheld from the moon when the dark side of the earth was presented to that orb, would appear only like a dim lucid speck, scarcely distinguishable from the other parts of the earth's surface. And if this be the case in respect to objects within such limited distances, what astonishing scenes may be the result of what we perceive in bodies many thousands of millions of miles distant, when we behold them disappearing to our view, or even when we perceive their light only increasing or diminishing? Here imagination is left to fill up the picture which the organs of vision so dimly perceive. We are to consider that the orbs to which we allude are luminous globes of immense size,—that they are doubtless encircled with a retinue of worlds replenished with inhabitants,—that what to us appears a slight change of aspect may to them be the commencement of an era of new glory and splendor,—that the Almighty rules over those distant regions as well as "among the inhabitants of the earth,"—and that all the changes which happen among them are in unison with his eternal designs, and subvert the ends of his universal government.

## CHAPTER VIII.

### ON DOUBLE STARS AND BINARY SYSTEMS.

In whatever part of creation we survey the operations of the Almighty, we uniformly find the characteristic of *variety* impressed upon all his works. This is evident in all the kingdoms of nature connected with our globe, where the multitude and diversity of animals, vegetables, and minerals, cannot but strike the eye even of the most superficial observer. Though the same general laws appear to pervade the material universe, so far as our observation extends, yet these laws are so comprehensive and so endlessly modified as to produce an immense variety of minute and wonderful effects. It is more difficult to trace the operation of these laws in the remote spaces of the universe than in our terrestrial sphere. But even in regions of creation immeasurably distant we can perceive the agency of the same powers which are at work in conducting the movements of our planetary system; and not only so, but we can trace these powers, while operating with their native energy, wonderfully modified, and producing effects altogether different from those which we experience in the system of which we form a part, evidently indicating that a *variety*, analogous to that which we behold in the scene around us, marks the operations of the Creator throughout the immensity of his works. This will more clearly appear in the descriptions we shall now give of the phenomena of double and multiple stars.

The phenomena of double stars do not seem to have been much attended to until Sir W. Herschel commenced his extensive observations on the sidereal heavens. About a century ago, the astronomers of that period seem to have been aware that "several stars which appear single to the bare eye are by the telescope discovered to be double." The principal stars of this description which they mention are,—the head of Castor, the first in the head of the Ram, the star *Gamma* in the breast of Virgo, and the middle one in the sword of Orion. Conceiving the fixed stars as bodies precisely of the same nature, and that no specific or diversified arrangements prevailed among them, they do not appear to have entered upon any minute surveys, by the telescope, of particular stars; and their idea respecting the double stars they had detected was merely this,—that a small star, at a very remote distance from another, might happen accidentally to lie nearly in the same line of vision as the larger one; and, on this ground, Dr. Long, in his "Astronomy," shows how the annual parallax would be discovered by a star appearing single at one time of the year, and double at another. It appears to have been chiefly with an object of this kind in view that Sir William Herschel commenced his numerous observations in this department of sidereal investigation. But, as we are informed by his son, who has distinguished himself in an eminent manner by similar observations, he had hardly entered on the measurements of the angles of position, and the distances of double stars, before

he was diverted from the original object of his inquiry by phenomena of a very unexpected character, which at once engrossed his whole attention. The circumstances alluded to shall be particularly described in the sequel, after I have given a brief sketch of the phenomena of double stars.

When a telescope of considerable power is directed to certain stars which appear single to the naked eye, another star, generally much smaller than that which appears to the unassisted eye, is seen quite adjacent to it, and in some cases the interval between the two stars is so small that it requires a very high degree of light and magnifying power to be able to perceive that they are two distinct bodies. Only a few, perhaps not exceeding six or eight, of these stars were known to the astronomers of the age preceding that of Herschel; but this illustrious astronomer, with unwearied perseverance, detected no less than 500 double stars, and presented to the Royal Society a list in which their situation and relative positions are distinctly marked. These observations of the elder Herschel were followed up by other observers, particularly by Sir J. Herschel and Sir James South, who, in the year 1824, soon after Sir W. Herschel had ceased from his labors, produced a catalogue of 380 double stars, whose distances and angles of position they had determined with the utmost accuracy and precision.—Sir J. South afterward produced a *distinct* catalogue of 480, and Sir J. Herschel a list of upward of 3300 of double and triple stars, from his own solitary observations, accompanied with all the micrometrical measurements. Struve, the celebrated astronomer of Dorpat, has arranged a catalogue of no less than 3000 double stars; and before he determined the characteristics of each of these, he examined about 120,000 stars—a laborious process, which none but an astronomical observer can duly appreciate. Mr. Dunlop has formed a catalogue of 250 double stars in the *southern* hemisphere; and Sir J. Herschel, during his late residence at the Cape of Good Hope, has added considerably to their number; so that we may now reckon about 6000 of these interesting objects as having already been discovered, even making allowance that many of these objects are common to the lists of the observers now specified.

It is not at all improbable that the phenomena of some of the double stars now alluded to may

Fig. 13.

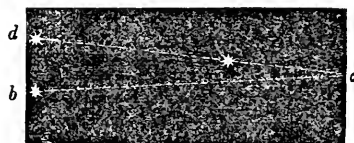

arise from *accidental proximity*, the one star, though far remote and unconnected with the other,

ying nearly in the same visual line. Thus, the star  $a$ , fig. 13, might appear nearly in contact with the star  $b$ , placed at an immense distance beyond it, when viewed nearly in the same straight line by the eye at  $c$ , so as to produce the phenomena of a double star at  $d b$ . But, reasoning *a priori*, it appears in the highest degree improbable that such coincidences should happen in the case of all, or even of the greater part of the double stars which have now been discovered; and therefore Mr. Mitchell, so early as the year 1783, in a paper inserted in the "Philosophical Transactions" for that year, states it as his opinion that they are binary systems intimately connected. "The very great number of stars," says he, "that have been discovered to be double, treble, &c., particularly by Mr. Herschel, if we apply the doctrine of chances, as I have done in my 'Inquiry into the probable Parallax of the Fixed Stars,' published in the Philosophical Transactions for 1767, cannot leave a doubt with any one properly acquainted with the force of those arguments, that by far the greatest part, if not all of them, are systems of stars so near each other as probably to be liable to be affected sensibly by their mutual gravitation; and it is therefore not unlikely that the periods of the revolutions of some of these about their principals may some time or other be discovered."

The prediction here announced by this ingenious gentleman has now been fully realized by Sir William Herschel and other astronomers, and is no longer a subject of conjecture, but an *ascertained fact*. This is the discovery to which I have alluded above, one of the most important and interesting discoveries which astronomy has unfolded during the present age, and which opens to our view a new prospect of the plans and arrangements of Infinite Wisdom.

Having made these preliminary remarks, I shall now proceed to a more particular detail of the facts which have been ascertained respecting binary systems.

When Sir W. Herschel first directed his attention to this subject, in order if possible to determine the annual parallax, he was not a little surprised that, instead of finding, as he expected, a regular annual change of the two stars, by one alternately shifting its position with respect to the other, which a parallax would have produced, he observed in many instances "a regular progressive change, in some cases bearing chiefly on their distance, in others on their position, and advancing steadily in one direction, so as clearly to indicate either a real motion of the stars themselves, or a general rectilinear motion of the sun and whole solar system, producing a parallax of a higher order than would arise from the earth's orbital motion." In an elaborate paper on this subject, read before the Royal Society, June 9, 1803, he considers specifically all the motions and combinations of motion that can possibly be supposed, in order to account for the phenomena, particularly of the double star *Castor*, and satisfactorily demonstrates that nothing but the idea of the smaller star revolving around the larger in a circular or elliptical orbit will solve the phenomena in question; and this conclusion has been amply confirmed by all succeeding observations. Such stars, therefore, must be considered as *physically connected* by the law of mutual gravitation, so that they describe orbits around each other and around their common center of gravity, and bear a relation to each other similar to that which the planets bear to our sun.

From the paper of Sir W. Herschel now referred to, I shall select, as a specimen of the motions of

double stars, some of his observations of *Castor*, or  $\alpha$  *Geminorum*. It appears that Dr. Bradley in the year 1759 had observed the position of the two stars which form this double star, and communicated it to Dr. Maskelyne, who made a memorandum of it, of which the following is a copy:—"Double star Castor. No change of position of the two stars; the line joining them at all times of the year, parallel to the line joining *Castor* and *Pollux* in the heavens, seen by the naked eye."—The object of Dr. Bradley in observing the exact position of these stars was, to determine if any change happened in their position at opposite periods of the year, so as to indicate an annual parallax. The angles of position observed by Sir W. Herschel are as follow:

Times of the observations.	Angles of Position.
November 1, 1759 .....	56° 32'
November 5, 1779 .....	35 29
February 23, 1791 .....	23 36
December 15, 1795 .....	18 32
March 26, 1800 .....	14 3
December 31, 1801 .....	12 12
February 28, 1802 .....	12 1
March 27, 1803 .....	10 53

From these observations it appears that from the year 1759, when Dr. Bradley observed the positions of the two stars, to the year 1803, there has been a portion of an orbit described by the smaller star around the greater equal to forty-five degrees and thirty-nine minutes; and from the time that Herschel commenced his observations in 1779 until 1803, an arch of twenty-four degrees and thirty-six minutes had been passed over.—Hence Sir W. Herschel concludes—"The time of a periodical revolution may now be calculated from the arch  $45^{\circ} 39'$ , which has been described in 43 years and 142 days. The regularity of the motion gives us great reason to conclude that the orbit in which the small stars moves about *Castor*, or rather the orbits in which they both move round their common center of gravity, are nearly circular and at right angles to the line in which we see them. If this should be nearly true, it follows that the time of a whole apparent revolution of the small star round *Castor* will be about 342 years and two months." This subject may be illustrated to the general reader by the following diagram:

Fig. 14.

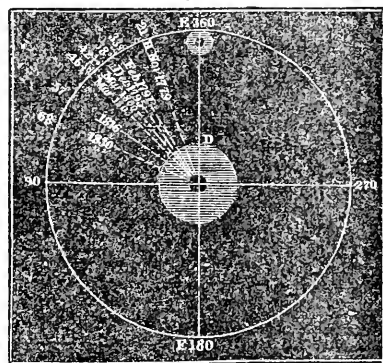

Let the small central circle  $C$  represent the larger star *Castor*, and  $D$  the smaller star, and let the line  $E F$  represent the direction of the two stars in a line with the star *Pollux*, at  $E$ , as observed by Dr. Bradley in 1759. In November,

1779, they were found in the position *CH*, twenty-one degrees from the position they occupied twenty years before; in February, 1791, they were thirty-three degrees from the same position, &c.; and in March, 1803, forty-six and a half degrees; giving evident indication of a regular progressive motion in a circle. Since 1803 its motion has been regularly traced by Struve, Sir J. Herschel, and Sir J. South; and in 1816 it was found about  $57^{\circ}$  from its first position, and in 1830 about  $68^{\circ}$ , still regularly progressing. In 1819, the distance of the small star from Castor was five seconds and a half, and in 1830 it was little more than four seconds and a half. Although Sir W. Herschel, as above stated, conjectured the period of revolution to be about 342 years, yet later astronomers, from a comparison of all the observations recently made, are disposed to conclude that its period is little more than 250 years.

More than fifty instances of changes in the angles of position of double stars were observed by Sir W. Herschel, beside those which have been more recently observed by his son and other astronomers, most of which indicate motions which are regularly *progressive*; but a considerable number of years must elapse before their periods can be determined with any degree of accuracy. The following double stars are considered as demonstrative instances of circular progressive motion:— $\gamma$  Virginis,  $\xi$  Ursæ Majoris, 70 Ophiuchi,  $\sigma$  and  $\eta$  Coronæ,  $\zeta$  Bootis,  $\eta$  Cassiopeiæ,  $\gamma$  Leonis,  $\zeta$  Herculis,  $\delta$  Cygni,  $\mu$  Bootis,  $\epsilon$  4 and  $\epsilon$  5 Lyræ,  $\lambda$  Ophiuchi,  $\mu$  Draconis,  $\epsilon$  Bootis, and  $\zeta$  Aquarii. The periodic times of some of these have been determined to a near approximation. One of the stars of *Gamma* Virginis is reckoned to revolve about the other in the space of 629 years; the small star of *Gamma* Leonis, in 1200 years; the star connected with *Epsilon* Bootis, in 1600 years; that of 61 Cygni, in 452 years; that of *Sigma* Coronæ, in 287 years; that of 70 Ophiuchi, as ascertained by Professor Encke, in 80 years; that of  $\lambda$  Ursæ, in 58 years; that of *Zeta* Cancri, in 55 years; and that of *Eta* Coronæ, in 43 years.

A whole revolution of some of these stars has been nearly completed since observations began to be made on such objects. The motion of the small star of  $\lambda$  Ursæ began to be traced about the year 1781; in 1819, it had moved  $219^{\circ}$  from its position in 1781; in 1830, it was 303 from that position, progressing in a circle; and about this time, or the beginning of 1840, it has probably finished its orbital revolution. The star *Eta* Coronæ, whose period is forty-three years, has not only accomplished a complete revolution, but is actually considerably advanced in its second period. Sir J. Herschel, during his late sojourn at the Cape of Good Hope, is said to have discovered in the southern skies, binary stars, whose periods of revolution are even shorter than those now stated, their change of position having been quite perceptible during the three or four years of his residence in that quarter. Sir W. Herschel, in the paper to which I have already referred, states observations which furnish us with a phenomenon which is new in astronomy—namely, the *occultation of one star by another*. With a power of 460, in July, 1782, the stars of *Zeta* Herculis were then half the diameter of the small star asunder; in 1795, he found it difficult to perceive the small star with the same power; in 1802, the small star could no longer be perceived, but the apparent disc of the large star seemed to be a little lengthened one way. With his ten feet telescope, and a power of 600, he found it to have the appearance

of a wedge-formed star. On the 11th of April, 1803, he examined the apparent disc with a power of 2140, and found it, as before, a little distorted, but there could not be more than about three-fourths of the apparent diameter of the small star wanting to a complete occultation. "Most probably," he observes, "the path of the motion is not quite central; if so, the disc will remain a little distorted during the whole time of the conjunction." This phenomenon evidently demonstrates the fact of circular orbital motion, performed in a plane nearly parallel to our line of vision.

The star *Gamma* Virginis has presented phenomena nearly similar to that of *Zeta* Herculis. This star is remarkable both for the length of its period, the rapid increase of the angular motion of the two stars of which it is composed, and particularly the *great diminution of their apparent distance*. It has been known as a double star for at least 120 years. The two stars of which it is composed, and which are nearly equal, were so far apart about the middle of the last century that they were marked in Mayer's catalogue as two distinct stars, so that any moderately good telescope would have shown their separation, being at that period about seven seconds distant from each other. Since that time they have been constantly approaching, and in 1833 were scarcely more than a single second asunder; so that a common telescope was insufficient to show their separation, and even telescopes of very superior power could show them no otherwise than as a single star somewhat elongated. According to Sir J. Herschel's computations, the small star must have arrived at its perihelion on the 16th of August, 1834. He also determined the *inclination of the orbit to the visual ray* to be  $22^{\circ} 55'$ , and the *angle of position of the perihelion* projected on the heavens,  $36^{\circ} 24'$ . The small star of *Eta* Coronæ reached its perihelion in 1835; and it is calculated that the revolving star of Castor will reach the same point during the year 1855.

From the observations that have been made on binary stars, it now appears demonstrable that the law of gravitation extends its influence to the starry regions; that the same laws of motion which direct the planets in their courses, and connect them with the sun as their center, likewise operate in these binary systems in carrying one star around the center of gravity of another. It has often been surmised that gravitation is a power which is universal in its influence; and here we have a proof that it extends not only beyond the range of the planetary system and the orbits of the most eccentric comets, not only to stars reckoned the nearest to our globe, but to those of the third, fourth, and even tenth magnitudes, which may be supposed many hundreds of billions of miles further distant; thus rendering it highly probable that it is a fundamental law of matter, and extends its energies throughout the amplitudes of creation, combining in one vast system all the operations of the Eternal.

The orbits in which the one star moves around the other are found to be *elliptical*, which is the same kind of curve in which the earth and the other planets move round the sun, in which the satellites of Jupiter, Saturn, and Uranus perform their revolutions round their respective primaries—another proof that the same general law operates in both cases. Some of these orbital motions are *retrograde* and others are *direct*, or in the same direction as the motions of the planets of our system. In some cases it happens that the edge of the orbit of the revolving star is presented



to the earth, or in a line nearly parallel to that of our vision, as is found in the star  $\alpha$  Serpentarii; in which case the star appears to move in a larger line, and to oscillate on each side of the larger star around which it revolves, in a manner similar to that of the satellites of Jupiter, which appear to pass from the one side to the other of the planet in nearly straight lines, because the plane of their orbits is nearly in a line with our eye. At the time when Sir W. Herschel first observed this binary system, the two stars were distinctly separate, but at present the small star is so completely projected on the other that even Struve, with his powerful telescope, cannot now perceive the least separation between the two bodies—a fact which evidently demonstrates that to our eye the one is passing across the disc of the other, and that a number of years hence it will appear on the other side of the larger star. On the other hand, the two stars of *Zeta* Orionis are now separated by a small interval, although they appeared as one star in the time of Sir W. Herschel; all which phenomena demonstrate a motion in a circular or elliptical orbit, the plane of which lies *oblique* to our eye; and it has been calculated, from the apparent motions of these bodies, that the ellipses in which they move are in general more elongated than the orbits of the solar planets. On the whole, to use the words of Sir John Herschel, “we have the same evidence of their rotations about each other that we have of those of Uranus and Saturn about the sun; and the correspondence between their calculated and observed places in such very elongated ellipses must be admitted to carry with it proof of the prevalence of the Newtonian law of gravity in their systems, of the very same nature and cogency as that of the calculated and observed places of comets round the central body of our own.”

Having stated the above general facts respecting binary stars, I shall now present to the reader a few telescopic views of these objects.

Fig 15 represents a telescopic view of *Epsilon* Bootis, with a magnifying power of about 250 times. This is reckoned a very beautiful double star on account of the different colors of the stars of which it is composed, and has an appearance somewhat similar to a planet and its satellite, both shining with innate but differently colored light. The small star is of a bluish color, and is separated from the other by a space equal to the diameter of the larger star, and its apparent size is one-third of the other. It is sometimes called *Mirac*, and it is situated about ten degrees north-east of *Arcturus*. The large star has a reddish tinge.

Fig 16 is  $\alpha$  Herculis: the small star is of a bluish color, separate from the other two diameters of the large star; the blue star is one-third the size of the other. It is situated in the head of Hercules, about thirty degrees south-west from the bright star  $\alpha$  Lyrae, and six degrees north-west from *Ras Alhague*, a star of nearly the same magnitude. It comes to the meridian about the middle of July, at nine o'clock in the evening, at an elevation of about fifty-two degrees. This star is also distinguished by the name *Ras Algethi*, and may be seen marked in Plate II, which contains a map of stars which are seen near the meridian about the beginning of September.

Fig. 17 is a view of  $\gamma$  Andromedæ: the small star is of a fine greenish-blue color, separate from the large star about nine seconds, or four diameters of that star; the larger star is of a reddish white. It is situated in the left foot of Andromeda, and is distinguished by the name *Almaack*. It is a star of the second magnitude, about forty-

two degrees of north declination. and passes the meridian, in the beginning of December, about half past ten in the evening, about ten degrees south from the zenith. It is about twelve degrees nearly due west from the variable star *Alcol*.

Fig. 18 is *Zeta* Cygni: the smaller star is blue, and they are separated about ten diameters. This star is situated in the eastern wing of the Swan—right ascension, 21h. 4, north declination, twenty-eight degrees, and is about twenty degrees south-east of *Denib*, the principal star of this constellation.

Fig. 19 represents *Zeta* Aquarii. The two stars are nearly equal in apparent magnitude, and one diameter and a half separate from each other; both stars are of a whitish color. It is in the middle of three other stars, which together form a figure resembling the letter Y. Its right ascension is 22h. 20', and its south declination about two degrees. It is a star of about the third magnitude, and comes to the meridian at nine o'clock in the evening about the middle of October.

Fig 20 represents the *Pole-star*. The accompanying star is a very faint point, and requires an accurate telescope with considerable power to distinguish it. The large star is white, and the small star somewhat of a ruddy appearance, and is distant from the larger seventeen seconds, or about three or four of its diameters.

Fig. 21 is the double star *Castor*. The smaller star is nearly half the size of the larger, and they are distant about five seconds, or two diameters of the principal star. They are both of a whitish color. Their situation may be found on Plate I. *Castor* and *Pollux* lie to the north-west of Orion, at a considerable distance from it. They are very conspicuous, are within five degrees of each other, and rise to a very high elevation when passing the meridian, and may be seen throughout the whole winter and spring months. *Castor* is the more elevated of the two.

Fig. 22 represents *Rigel*, a splendid star in the left foot of Orion. The small star is a mere point, and very difficult to be distinguished, and is three or four diameters of the large star from it. The large star is white, the small one of a reddish hue.

Fig. 23 shows the double star *Castor*, with a magnifying power of 300. It likewise shows the angular position of the small star at the present time in respect to *Pollux*, (fig. 24), by which it appears that it is nearly at a right angle to a line joining *Castor* and *Pollux*.

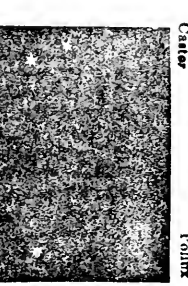
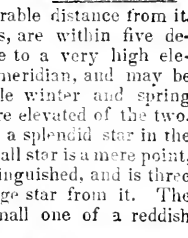
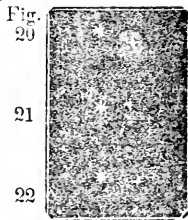
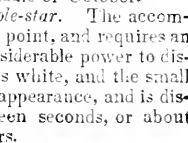
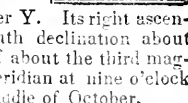
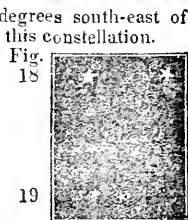
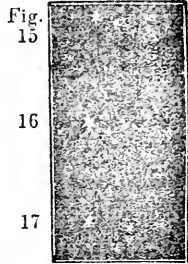

Castor  
Pollux

lux, whereas in the time of Dr. Bradley it was parallel with a line joining these two stars.

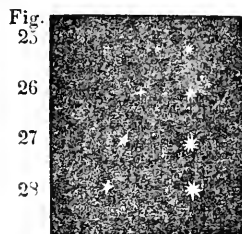

Fig. 25, 26, 27, and 28, exhibit views of the double star *Epsilon* Bootis, with four magnifying powers. Fig. 25 is its appearance with a power of 227; fig. 26, with a power of 460; fig. 27, with a power of 900; and fig. 28,

Bootis.

with a power of 1100.

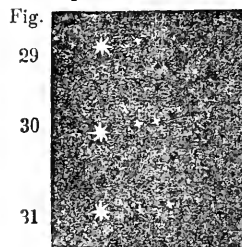

Fig. 29, 30, and 31, represent telescopic views of the triple star in the left fore-foot of the constellation *Monoceros*, or the Unicorn, which forms a very beautiful object in this class of stars. This star appeared at first double, but with

Monoceros.

some attention, one of the two is discovered to be also double; the first of them is the largest. The color of these stars is white. With a small power they appear as in fig. 29; with a power of 220, as in fig. 30; and with a power of 450, as in fig. 31. There is a beautiful object of this description, but somewhat different in the configuration of the three stars of which it is composed, to be seen in the tail of the great Bear; it is the star *Zeta* Ursæ, called also *Mizar*, and is the middle star in the tail.

Such are a few specimens of the telescopic appearances of this class of celestial objects. Some of these objects, in order to be distinctly seen, require telescopes of considerable magnifying power. All the objects, however, referred to above may be seen with a good three feet and a half achromatic telescope, whose object-glass is two inches and three quarters aperture. The double star *Castor* may be seen with powers of 80, 140, and 180. I have frequently distinguished the separation of the two stars with a terrestrial power of only 45; but the higher powers of course are much preferable. In order to perceive the very small star or point of light adjacent to the pole-star, a power of 140 at least is requisite with such a telescope; but it is more distinctly seen with a power of 190 or 200. It is considered as a fair test of the goodness of a telescope of this description when this minute object is perceptible with such powers. The small star connected with *Epsilon* Bootis is likewise an object which requires a considerable degree of magnifying power and distinctness to perceive the separation of the two stars; and it is more difficult to perceive the small star adjacent to *Rigel* than any of these objects.

adjacent to a larger star, and to be informed that this lucid point revolves around its larger attendant; but this phenomenon, minute and trivial as it may at first sight appear, proclaims the astonishing fact, that SUNS REVOLVE AROUND SUNS, AND SYSTEMS AROUND SYSTEMS. This is a comparatively new idea, derived from our late sidereal investigations, and forms one of the most sublime conceptions which the modern discoveries of astronomy have imparted. It undoubtedly conveys a very sublime idea, to contemplate such a globe as the planet *Jupiter*—a body thirteen hundred times larger than the earth—revolving around the sun, at the rate of twenty-nine thousand miles every hour; and the planet *Saturn*, with its rings and moons revolving in a similar manner round this central orb in an orbit of five thousand, six hundred and ninety millions of miles in circumference. But how much more august and overpowering the conception of a sun revolving around another sun—of a sun encircled with a retinue of huge planetary bodies, all in rapid motion, revolving round a distant sun, over a circumference a hundred times larger than what has been now stated, and with a velocity perhaps a hundred times greater than that of either *Jupiter* or *Saturn*, and carrying all its planets, satellites, comets, or other globes along with it in its swift career! Such a sun, too, may as far exceed these planets in size as our sun transcends in magnitude either this earth or the planet *Venus*, the bulk of any one of which scarcely amounts to the thirteen-hundred-thousandth part of the solar orb which enlightens our day. The farther we advance in our explorations of the distant regions of space, and the more minute and specific our investigations are, the more august and astonishing are the scenes which open to our view, and the more elevated do our conceptions become of the grandeur of that Almighty Being who “marshaled all the starry hosts;” and of the multiplicity and variety of arrangements he has introduced into his vast creation. And this consideration ought to serve as an argument to every rational being, both in a scientific and a religious point of view, to stimulate him to a study of the operations of the Most High, who is “wonderful in counsel and excellent in working,” and whose works in every part of his dominions admire the glory of his perfections, and proclaim the depths of his wisdom and the greatness of his power.

In order to form a comprehensive conception and a proper estimate of such binary systems, we have to consider, in the first place, the distances of the stars or suns from each other. These distances, in the meantime, cannot be accurately ascertained until something more definite be determined respecting the parallaxes of these bodies. Some have supposed that the distance between some of these binary stars may be as great as the distance between the earth and any of these stars. But such a supposition is highly improbable, if we admit, what is now completely ascertained, that these bodies are intimately connected by the law of gravitation. Their distance, however, must be very great, notwithstanding their apparent nearness to each other, as a few seconds of interval, at the distance of the nearest star, must comprise an immense space. I shall suppose this distance in the case of some of these bodies to be only the one-hundredth part of what is reckoned the distance (namely, twenty billions) of the nearest star. On this supposition, the distance of the revolving star from its primary would be 260,000,000,000, or two hundred thousand mil-

In the phenomena I have now described, we have a new and interesting scene presented before us, which leads the mind into a train of thought very different from what could have been conceived by astronomers of a former age. To some minds, not accustomed to deep reflection, it may appear a very trivial fact to behold a small and scarcely distinguishable point of light immediately

ions of miles. The circumference of its orbit would therefore be 1,256,640,000,000 of miles. The small star of  $\xi$  Ursæ completes its revolution in fifty-eight years, and consequently, if at the distance now supposed from its primary, must move at the rate of two millions four hundred and seventy-one thousand miles every hour, which is eighty-five times the velocity of the planet Jupiter, and more than twenty-three times the velocity of Mercury in its orbit, which is the swiftest moving planet in our system. This motion would be still more swift in the case of some of the other stars to which we have alluded. The small star of *6 Eridani*, as determined by Mr. Dunlop, revolves around the larger at the rate of somewhat more than ten and a half degrees per annum, and consequently accomplishes a revolution in little more than thirty years. Its motion, then, at the distance supposed, would be equal to four millions seven hundred thousand miles an hour, which is 162 times the velocity of Jupiter, and about forty-four times that of Mercury. Even the small star of  $\gamma$  Leonis, which takes 1200 years to accomplish its revolution, would, on the same supposition, move at the rate of 119,000 miles an hour, which is a greater velocity than that of the swiftest planets of our system. These are immense velocities, especially when we consider the enormous size of the bodies thus impelled; for the least of these suns may be considered as *ten millions* of times larger than the planet Mercury, yet moving with a velocity so much superior.

What, then, would be the velocities of such bodies were we to suppose them as far distant from each other as we are from the nearest star! In the case of *Xi Ursæ*, the velocity would be two hundred and forty-seven millions, one hundred and sixty thousand miles every hour, and four millions, one hundred and fifty thousand every minute; and in the case of *6 Eridani*, the velocity would be 477,800,000 miles an hour, and 132,735 in a *second*, which is more than sixteen thousand times the velocity of Jupiter. That bodies may move with such velocity is perhaps not impossible, but it is highly improbable that such rapid motions actually exist among bodies of such astonishing magnitudes; and therefore we must suppose that the binary stars are within a moderate distance of each other. Still, that distance must be very considerable, and it is not unlikely may be as great as I have supposed, and if so, it presents to our view motions more rapid and sublime than any which are known to exist within the limits of our planetary system.

In the next place, we must consider the *system of planets* connected with the binary stars. These stars are evidently suns or self-luminous bodies, otherwise their light would never reach our distant sphere. But we can never admit that suns were created merely to diffuse a useless splendor over the waste spaces of infinity, where there are no sentient beings with visual organs to be cheered with their radiance. In this case they might be said to be created in vain. Hence we must necessarily conclude that these suns are attended with a retinue of planetary bodies, which revolve around them as the centers of light and attractive influence, and we can scarcely conceive a more sublime and astonishing object than that of magnificent suns revolving around still more magnificent and luminous centers, and conveying along with them in their swift career a numerous train of mighty worlds, all in regular and rapid motion around their respective orbs. In such sublime sidereal arrangements we behold a combination of motions and effects of gravitation which are

not to be traced throughout any part of the system to which we belong. For while the planets which perform their revolutions around the revolving sun, are affected by the power of attraction from that body with which they are more immediately connected, they must likewise be attracted by the larger central sun, and their motions sometimes retarded, sometimes accelerated, and variously modified, by its powerful influence, which combined influences must produce a diversity of phenomena and effects unknown in the system of our sun. For the sake of some readers, not accustomed to such views and contemplations, I have given a rude sketch of a binary system in fig. 32, in which the central circles represent the larger sun with its attendant planets, and the other circles the revolving sun and its planets, in four different positions.

Again, in contemplating these binary systems, we perceive a great diversity in the periods of their revolutions. The period of revolution of the small star of  $\delta$  Bootis is calculated to be not less than 1600 years. An inhabitant of that system would be considered by us an old resident were he to survive the period of a year, or a single revolution. But in such systems it is not likely that the lapse of duration is marked by so short periods as in our own sublunary abode, nor is it probable that disease and death cut short the existence of its inhabitants, as in the world in which we dwell. Another of these suns takes 1200 years to complete a revolution; another, 629 years; and another, 452; while several others finish their circuits in the comparatively short periods of 55, 43, and even 30 years. Whether these diversities in the periods of revolution be owing to the different magnitudes of the respective bodies, their distances from each other, the amplitudes of the orbits in which they move, or the comparative velocities with which they are carried forward in their career, we have as yet been unable to determine; and a long-continued series of the most delicate and minute investigation is still requisite before such points can be ascertained with any degree of precision. But such striking differences in their periodic revolutions evidently indicate that the characteristic of *variety* is impressed upon all the arrangements connected with those distant systems; which lead us to conclude that there is no system of suns or worlds in the universe exactly resembling another, although they may be all subject to the operation of the same general and fundamental laws. From such circumstances we are likewise led to infer that among bodies in the more distant regions of creation there may be motions and arrangements altogether different from anything we yet know, which produce scenes of beauty, sublimity, and grandeur, far surpassing what the mind of man can yet conceive.

In regard to the *number* of such binary systems, no precise estimate has yet been made. We have, however, every reason to believe that their number is very great. I have already stated that about 6000 double stars have been detected by M. Struve, the two Herschels, Mr. Dunlop, and Sir James South. On the doctrine of chances, it is in the highest degree improbable that the greater part, or even any considerable number of these bodies, appear double by their accidental proximity, or being so placed one behind another as to be nearly in the same line of vision. We may therefore conclude that at least 4000 of these stars are binary systems connected by the law of mutual gravitation. Between forty and fifty of these bodies have been ascertained beyond doubt to form

revolving systems, and time must be allowed for further investigations. It is but lately that the attention of astronomers has been directed to such observations; and on account of the very minute distances of the revolving stars from each other, and the slight variation of the angle of position which can be traced for a series of years, an age or two is requisite in order to determine with precision the degree or progress of their revolutionary movements. Some of their orbits, too, may be so extensive, or their motions so comparatively slow, that several thousands of years may elapse before the periods of some of these bodies be completed; and if so, we have no reason to conclude that they are *not* binary systems, although half a century should elapse without any change being perceived in their angular positions. In the course of fifty or sixty years hence, we have reason to believe many important discoveries will be made in reference to the bodies in question, and what is at present doubtful or obscure will be rendered definite and precise. In the meantime, we may safely take for granted that several thousands of those revolving suns and systems lie within the range of our telescopes, whose revolutions will ere long be determined. But as our most powerful instruments can carry us only a very small way, comparatively, beyond the outward boundaries of those mighty heavens which surround us, ten thousands of such systems may exist in those remoter regions, which will forever remain inexplorably by mortals.

There is another interesting view which may be taken of these binary systems, and that is—the contrast of colors which some of the stars composing these systems exhibit. I have already alluded to some of these stars being of different colors, and any observer who is possessed of a good telescope may easily satisfy himself on this point. “Many of the double stars,” says Sir J. Herschel, “exhibit the beautiful and curious phenomena of contrasted or complementary colors. In such instances, the larger star is usually of a ruddy or orange hue, while the smaller one appears blue or green; probably in virtue of that general law of optics which provides that when the retina is under the influence of excitement by any bright-colored light, feebler lights, when seen alone would produce no sensation but of whiteness, shall for the time appear colored with the tint complementary to that of the brighter. Thus a yellow color predominating in the light of the brighter star, that of the less bright one in the same field of view will appear blue; while if the tint of the brighter star verge to crimson, that of the other will exhibit a tendency to green, or even appear as a vivid green under favorable circumstances. The former contrast is beautifully exhibited by *Iota Cancri*, the latter by *Gamma Andromedæ*, both fine double stars. If, however, the colored star be much the less bright of the two, it will not materially affect the other. Thus, for instance, *Eta Cassiopeæ* exhibits the beautiful combination of a large white star and a small one of a rich ruddy purple. It is by no means, however, intended to say that in all such cases one of the colors is a mere effect of contrast; and it may be easier suggested in words than conceived in imagination, what variety of illumination *two suns*, a red and a green, or a yellow and a blue one, must afford a planet circulating about either; and what charming contrasts and ‘grateful vicissitudes’—a red and a green day, for instance, alternating with a white one and with darkness—might arise from the presence or absence of one or other, or both, above the horizon. Insulated stars

of a red color, almost as deep as that of blood, occur in many parts of the heavens, but no green or blue star (of any decided hue) has, we believe, ever been noticed unassociated with a companion brighter than itself.”

The fact of *colored suns*, of suns belonging to the same system diffusing light of opposite or contrasted colors, presents a novel and interesting idea, and a splendid scene, in which a lively imagination may luxuriate, and depicting the diversity of aspects under which objects will appear in those worlds which are alternately illuminated by such a variety of irradiation. It is somewhat difficult, however, to form a distinct conception of the particular beauties, subtleties, and contrasts, which will be produced by such admirable arrangements. We are unaccustomed to the nature and qualities of the substances which are thus illuminated, and therefore cannot determine the peculiar hues or splendor which will result from the reflection of such irradiations; but we may easily conceive there will be a considerable difference in the variety and splendor of such illuminations, and in the contrast of color which will be exhibited when the revolving planets are in different parts of their orbits. When in such positions as *A, B, C, D* (fig. 32), they will be more directly under the influence of both suns than when at *E* and *F*, and of course the effect

Fig. 32.

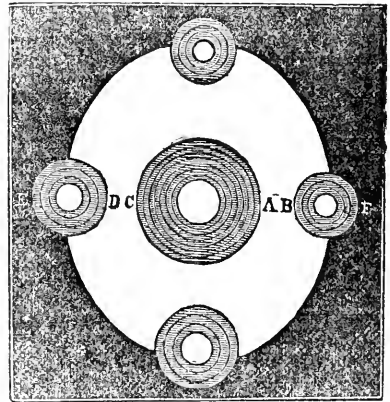

of the contrasted colored rays will be most remarkable. One hemisphere of a planet may be illuminated with a yellow sun, while the other is at the same time enlightened by a green, and both suns may occasionally shine in the same hemisphere, producing such a blending of hues, and a contrast of coloring over the whole landscape, as to render the aspect of the scene completely different at one time from what it is at another. In different parts of the planets' courses around their primary suns these effects will be variously modified, so as to produce an almost perpetual variety in the scenery of such worlds. A sun of a brilliant white color may perhaps be seen rising, while a sun of a ruby hue is descending below the horizon, and when both suns are absent, the starry firmament will appear in all its splendor, and every object around present a contrast to its previous appearance.

The science of optics, and particularly the experiments which have been made on *polarized light*, show us what a variety of combinations of vivid and beautiful colors may be produced by certain modifications of light, which may easily

lead us to conceive of the sublime and diversified brilliancy of coloring which must be the result of the irradiation of suns of different hues. The light of the stars in general is greatly diversified, although on a cursory view of the firmament they appear nearly of the same aspect. The rays of *Sirius*, for example, are not only strikingly different from those of *Aldebaran*, but from those of many other stars which seem to bear a nearer resemblance. In tropical climates, where the sky is clearer than with us, and almost of a dark ebony color, the different hues of the stars are more striking and perceptible to the naked eye than when seen through our comparatively hazy atmosphere. In this respect then, as well as in several others, the declaration of the inspired writer is literally true, that "one star differeth from another star in glory." Milton, in the eighth book of his "Paradise Lost," utters a sentiment on this subject which seems to be almost prophetic, when he represents Raphael in his address to Adam as saying—

"Other suns, perhaps,  
With their attendant moons thou wilt descry,  
*Communicating male and female light,*  
Which two great sexes animate the world,  
Stored in each orb, perhaps, with some that live."

In these phenomena we have another proof of the infinite variety which the Creator has introduced into the systems of the universe—a variety in regard to color as well as to magnitude, motion and other arrangements,—which leads us to conclude that although we were permitted to make the tour of universal nature, we should meet with no worlds, or systems of worlds, in which the scenery and arrangements are exactly the same, but that each would display its own peculiar harmonies, beauties, and sublimities, and the enraptured spectator, at every stage of his excursion, would behold a new manifestation of "the manifold wisdom of God."

It would be an important and interesting acquisition in astronomy could we determine exactly, or even to a near approximation, the distances of any of these binary systems, and the actual dimensions of the orbits of the revolving stars. It appears from what has been formerly stated (pp. 51, 52,) that the parallax, and consequently the distance, of *61 Cygni* has been determined by Professor Bessel. Now this is a double star, or binary system, and one of the stars is found to have an annular angular motion of about two-thirds of a degree; from which it is inferred that the period of its revolution may be about 540 years, and that the semi-major axis of its orbit is seen under an angle of more than 15". Were these and other correlative points accurately settled, we might soon determine to a near approximation the extent of its orbit, the space through which it moves in the course of a revolution, and consequently its rate of velocity; but as the motion of revolution of this star is so extremely slow, a considerable period of years may elapse until all the elements of its orbit be accurately ascertained.

A few years ago, a method was pointed out by M. Savary, a French Astronomer, by which the dimensions of the orbit of a revolving star might be determined. This method depends upon the fact that light moves with a certain known rate of velocity. Suppose that one of the double stars moves round another in an orbit which is nearly parallel to our line of vision, it is evident that the one half of its orbit will be nearer to us than the other, and that at the most distant point of its course the star will be removed from us to a dis-

tance equal, or nearly equal, to the whole diameter of its orbit farther than when at the point which is nearest the earth. As the light which proceeds from the star takes a certain time in moving across the interval which separates us from that body before it reach our eye, we must necessarily see the star in a point of its orbit different from that in which it is actually placed. Let *S* (fig. 33) represent the central star, *E* the earth, and *H F K G* the orbit of the revolving star. When the star is at *H* it is nearest the earth; and when at *K* it is farther distant by the whole diameter of its orbit. Now, when the star proceeds from *H*, the nearest point of its orbit, its light will take a longer period to reach the earth in proportion as it moves on in its course from *H* to *G* and from *G* to *K*, and consequently will appear to take a longer time than in reality it does in moving along that portion of its orbit; but in returning through the other half of its orbit, *K F H*, it will appear to pass through it in a less space of time than it actually does, since the light which proceeds from it takes less and less time to reach our eye as it approaches in its course toward *F* and *H*. It, therefore, we could accurately determine the difference of time between these two half revolutions of the star, we should have data sufficient for determining, to a near approximation, the dimensions of the orbit in miles, or other known measures; and having found these dimensions, the distance of the star from the earth could likewise be found by an easy trigonometrical calculation.

This method of finding the dimensions of binary systems is entitled to the praise of ingenuity; but it will be difficult, in many instances, to put it in practice. Its accuracy will depend upon our knowing the position of the orbit with regard to our eye, and our ascertaining exactly when the star is in *H* or at *K*, or the two opposite points of its orbit. Beside, a very long time must intervene before observations of this kind can be completed, since most of the periods

that have been determined in regard to double stars extend to several hundreds of years, and the shortest period yet known of any of these revolving bodies is above thirty years. It is generally taken for granted, by those who have adverted to this subject, that the distance between the revolving and the central star is as great, or nearly as great, as that which intervenes between us and the nearest star; and hence, in their illustration of this point, they have supposed light to take at least one year in crossing the orbit of a revolving star, which of course would make the diameter of such an orbit above six billions of miles. But there appears no reason for forming such extravagant suppositions, as in such a case the binary stars could scarcely be supposed to have an intimate connection. We might almost as soon suppose that the star *Sirius* might revolve around our sun, or the sun around *Sirius*. It is not likely that the double stars in general are much farther from each other than the distance *I*

Fig. 33.

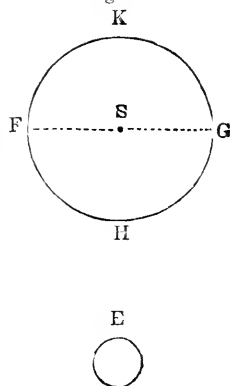

formerly supposed; namely, 200,000,000,000, and consequently the diameter of their orbits about 400,000,000,000, of miles. Through this space light would pass in the course of 24 days and  $22\frac{2}{3}$  hours; and therefore it would require very accurate determinations indeed of the points *H* and *K*, or the nearest and remotest points of the orbits, before any precise conclusions could be deduced,

if the stars be not farther distant than I have supposed, and it is perhaps as probable that they are considerably within that distance. It is not improbable, however, that the dimensions of the orbits of some of those stars whose periods are shortest may in this way be determined; but a considerable period must elapse before the requisite operations can be made.

## CHAPTER IX.

### ON TREBLE, QUADRUPLE, AND MULTIPLE STARS.

BESIDE the combinations of double stars described in the preceding chapter, treble, quadruple, and multiple stars have been discovered, many of which appear to be ultimately connected, and to be formed into regular systems, whose motions and phenomena must of course be more diversified and complicated than those of binary systems. Without entering into particular discussions on this subject, I shall present to the reader only two or three general remarks, with a short list of some of the treble and multiple stars to which I allude.

The more profound and minute our investigations are into the scenery of the heavens the more do we discover of the endlessly diversified modes by which the system of universal nature is arranged and conducted, and the more clearly do we perceive a display of the infinite wisdom and intelligence of its Almighty Author. Who could have previously conceived of one sun and system revolving round another, had not recent observations demonstrated the astonishing fact? As one discovery naturally leads to another, so the facts which have already been ascertained may lead to discoveries in future generations still more wonderful and sublime than those which have hitherto been brought to light. The discovery of binary systems leads to the conclusion that almost all the close groups, or clustering stars, visible to the naked eye or described by telescopes, are multiple systems, or suns and planetary worlds linked together by a universal law or

their attention more particularly to such objects, to watch with care the slightest movements in the sidereal heavens, and take their measurements of distances and angular positions with the utmost precision; and then we may expect that succeeding generations will have unfolded to their view a more sublime and comprehensive prospect of the arrangements of the universe.

In certain cases it has already been ascertained that treble stars form one connected system. The star marked  $\zeta$  Cancri is a treble star of this description. Two of the stars are considerably unequal; the largest of these is larger than the single star, and the least of the two is less than the single star. The first and second largest, as described by Sir W. Herschel, are pretty unequal, and the second and third pretty unequal. The nearest are pale red. They require very favorable circumstances to be distinctly seen; they are just separated by a power of 227, and with 460 their distance is  $\frac{1}{4}$  the diameter of the smaller one. This is considered a case in which three suns revolve around a common center. Observation has not yet afforded a sufficient data for determining the particular motions or arrangements of such complex systems; but we may conceive them as arranged in a manner somewhat similar to what we have delineated in fig. 34, where the point *C* may represent the common center of gravity around which the three bodies revolve. The circles *AB*, *DE*, *FG*, represent the orbits of the revolving bodies, which may be conceived as lying in different planes oblique to each other, to prevent any occasional collision or too near an approach.

Fig. 34.

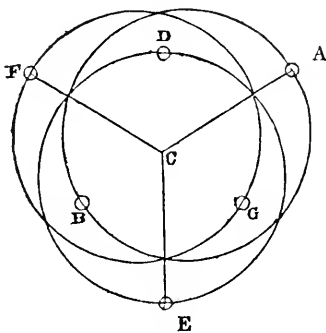

principle, acting in different modes, and producing an immense variety of physical phenomena and effects. Guided by principles and facts recently brought to light, astronomers have only to direct

Fig. 35.

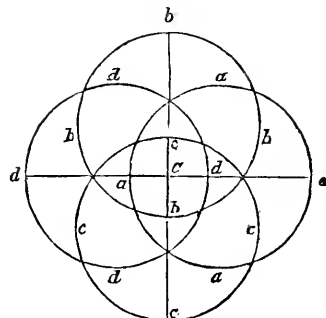

A quadruple system may be represented by fig. 35, where *C* is the center of gravity round which the four bodies revolve, and the circles *a a a a*,

*b b b b*, &c., the respective orbits in which they move. The star  $\epsilon$  Lyrae is probably a system of this kind. It is a star of the fifth magnitude, situated about two degrees north-east from the bright star *Vega*, or  $\alpha$  Lyrae. The stars of which it is composed are easily distinguishable by a telescope of moderate power, and it is easily found from its vicinity to the very bright star adjacent to it. The small stars of which it is composed are situated nearly as represented in fig. 36. We might conceive of such a system of bodies revolving in a still more complex manner,—the star *V* revolving round *S*, the star *U* revolving round *T*, the system of *V* and *S* revolving round a point *a*, and the system of *U* and *T* round the same point or center in a separate but more expansive orbit. But it is difficult to form diagrams of such complex systems.

Fig. 36.

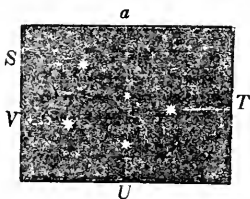
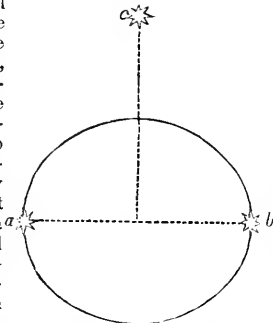

Fig. 37.



There are many different combinations by which we may conceive treble, quadruple, and multiple stars to revolve round their common center of gravity, which it would be too tedious to describe, particularly as such motions have not yet been accurately ascertained. Sir W. Herschel describes one of these possible combinations which is not a little singular. Suppose two equal stars, *a* and *b* (fig. 37), moving in a circular orbit round their common center of gravity, which will be the center of the circle. From the center of the circle, draw a line perpendicular to the plane of their orbit, extending to equal distances above and below this center. Let us now suppose a third star, *c*, to fall from one extremity of this perpendicular, from a state of rest; it will obviously descend with a gradually accelerated motion until it reaches the center of gravity; and passing onward with a motion gradually retarded, it will move to the other end of the perpendicular, where it will arrive at a state of rest, and again return and continue to oscillate between these two points. The two stars which move in a circular orbit may describe equal ellipses of any degree of eccentricity. In this case, however, the perturbations will affect not only the planes of their orbits, but also their figures; and the length of the oscillations of the third will be sometimes increased and diminished.

A sun oscillating in a line perpendicular to the orbit of other two suns, and continuing its motion for ages in that line, is certainly a very strange idea; and yet, from the variety we perceive in the arrangements of the universe, it is not at all improbable that such combinations may exist among treble stars. The idea here intended to be conveyed may be illustrated by suspending a ring,

and placing a wire perpendicular to it in its center. The ring will represent the plane of the orbit in which the two equal stars move, and the perpendicular wire the line or course of the third star moving backward and forward with different degrees of accelerated and retarded motion. The motions connected with quintuple and multiple stars must be still more complex than those to which we have adverted; but it is difficult in the meantime to form any distinct ideas on the subject, until actual observation in the course of succeeding ages shall pave the way for deducing definite conclusions. The discoveries already made open to view new scenes of celestial mechanism, and new views of the diversified and admirable contrivances of Divine Wisdom, so that, in reference to such objects, we may apply to the almighty architect the language of the sacred writer—"How unsearchable are thine operations and thy ways past finding out!" When we consider that around each of these moving suns a retinue of planets must be supposed to wheel their courses, at different distances and in different periods of time, we cannot but feel astonished at the complexity of motions, perturbations, and other effects which must necessarily follow; yet we are bound to believe that everything moves onward, not only without confusion, but in the most perfect order and harmony, for He who at first arranged the plan of the material world, and impressed upon matter the laws which now operate, is possessed of boundless intelligence, and foresees at one glance all the effects which those laws can possibly produce; and, so far as our observation extends, every object and movement in nature appears to be adjusted with the most perfect regularity.

The solution of the "problem of three bodies" was considered as a work of so great nicety and difficulty that none but such profound mathematicians as Clairaut, D'Alembert, and Euler, could undertake such a delicate and laborious investigation. This problem was, "to determine the curves described by three bodies projected from three points given in position, and with velocities given in quantity and direction—the force with which they gravitate being directly as their quantities of matter, and inversely as the squares of their distance." If the resolution of such a problem required so great acuteness of intellect, and so eminent skill in the science of analysis, what perspicacity of intellect, and what profound knowledge of everything connected with physical and mathematical investigations must be requisite to determine the courses described and the perturbations produced by the complex motions of five, six, or seven suns all connected together, yet moving in different curves and in different directions, along with hundreds of planets, each connected with its own sun and pursuing its own distinct course, yet acted upon in succession with different degrees of force by the attractive influence of other suns! All our boasted powers of analysis are completely incompetent for such determinations. The faculties of an archangel, or of intelligences of a higher order than that of man, are alone adequate to such investigations; and this circumstance affords a presumptive evidence that such superior intelligences actually exist in the universe, and that man, in the present improvement of his powers, may be in the act of training for the employments and the society of such intellectual beings in a future scene of existence.

The following brief list of treble and multiple stars, selected chiefly from Sir W. Herschel's

catalogue, is given for the sake of those who may be disposed to inspect them with their telescopes.\*

$\pi$ , or 42 *Aries*, in the *ham*, sixth magnitude.—The three stars, which are all in a line, are excessively unequal; the largest is white, and the two smallest are mere points. With a power of 460, the two nearest are  $1\frac{1}{2}$  diameter of the largest star. The third is about  $25''$  from the largest.

$\epsilon$ , or 4 or 5 *Libra*.—This is a remarkable double-double star—or a double star, each star itself being a double star. The first set consists of stars that are considerably unequal. The largest is very white, and the smallest reddish. Their distance with 227 is one diameter of the larger one; the second set are white and equal, the preceding being rather the largest; their distance  $1\frac{1}{2}$  diameter of either. The star appears of the fourth magnitude.

$\sigma$ , or 48 *Orion*, a star of the fourth magnitude, a little below the lowest of the three stars in the belt. This is a double-treble star, or two sets of treble stars, almost similarly situated. The two nearest of the preceding set are equal; the third larger, and pretty unequal when compared with the latter two. With a power of 222, the distance of the two nearest is two diameters of either. The two nearest of the following set are very unequal. The largest of the two and the farthest are considerably unequal, the largest being white and the smallest bluish. With a power of 222, their distance is about  $2\frac{1}{2}$  diameters of the largest. The distance of the two farthest is  $43''$ . Right ascension, 5h. 30'; south declination,  $2^{\circ} 43'$ .

$\delta$ , or 41 *Orion*, the small telescopic trapezium in the *nebula*. Right ascension, 5h. 26'; south dec.,  $5^{\circ} 32'$ . The stars composing this quadruple star are considerably unequal. The most southern star of the following side of the trapezium is the largest; and the star in the opposite corner is the smallest, the other two being nearly equal. The largest is pale red; the star preceding the largest inclined to garnet; and the star opposite the largest, dusky. Distance of the two stars in the preceding side,  $83\frac{1}{4}$  seconds; in the southern side,  $12\frac{3}{4}$  seconds; in the following side, 15 seconds; and in the northern side, 29 seconds. The first star (in right ascension) is of the seventh magnitude, the second of the eighth magnitude, the third of the fifth magnitude, and the fourth of the sixth or seventh magnitude. M. Struve found the angles of position, in 1819, to be as follows—

3d and 4th: 29° 45' north following.	1st and 2d: 45° 9' north preceding.
1st and 2d: 59° 8' north fol.	2d and 4th: 31° 0' north pre
	3d and 3d: 74° 0' north pre.

41 *Orion* preceding the two *t's*, or below 1, 2, 6—of the third or fourth magnitude. The preceding set of this double-triple star consists of three equal stars, forming a triangle, and are all dusky. The distance of the two nearest with a power of 227 is about 3 diam. The following set consists of three stars of different sizes, forming a circle. The middle star is the largest; the one to the south is pretty large; and the third is very small. The two largest are white, and the smallest pale red. Distance  $361\frac{1}{4}''$ . These stars are east by north from the bright star *Rigel*, at the distance of about  $5^{\circ}$ .

12 *Lynx*, below the eye; about  $18^{\circ}$  or  $19^{\circ}$  north-east of *Capella* and  $16^{\circ}$  north of  $\epsilon$  *Aurigæ*. The

two nearest of this curious treble star are pretty unequal. The larger is white, and the smaller white inclining to a rose color. With a power of 227 their distance is  $\frac{1}{2}$  the diameter of the smaller one. The first and third are considerably unequal; the second and third pretty unequal; the color of the third being pale red, and its distance from the first  $9''$ .

$\zeta$ , or 51 *Libra*; of the fourth or fifth magnitude. This star appears at first double, but the larger of the two will be found to consist of two stars. They are nearly unequal, and both white. With a power of 460 their distance is  $\frac{3}{4}$  the diameter of the larger.

$\gamma$ , or 53 *Aurigæ*, in a line parallel to  $\beta$  and  $\delta$ , south-east of the bright star *Capella*. This is a cluster of stars containing a double star of the second class and one of the third. The two of the second are very unequal, and both red. Their distance with 460 is  $2\frac{1}{2}$  diameters of the larger. Those of the third class are equal, and both red. Distance,  $17''$ . Above 20 stars are in view with a power of 227.

A large star  $1^{\circ}$  preceding  $\zeta$  toward 41 of the *Swan*. The two nearest are extremely unequal. The largest is white, and the smallest pale red. Their distance with 460 is  $2\frac{1}{2}$  diameters of the largest. The third and the largest are extremely unequal, and belong to the fifth or sixth class.

South preceding 27 *Swan*, the middle of three, the most southern of which is the 27. This star is quadruple and sextuple. In the quadruple of north preceding set, the two nearest are very unequal. Their distance with 678 is  $11''$ . The two largest are almost equal, and both red. Distance,  $29\frac{1}{2}''$ . In the sextuple or south following set, the two largest are pretty unequal, and both red. Their distance is  $19''$ .—The other stars are as small as the smallest of the quadruple set.

$\gamma$ , or 53 *Aurigæ*, north preceding  $\Pi$  *Geniæ* (of the fifth magnitude), in a line parallel to the  $\delta$  *Orion* (in the club, and of the fifth magnitude), and  $\zeta$  *Taurus*, the middle of the three. The stars in this quintuple star are in the form of a cross. The two nearest, or the preceding of the five, are extremely unequal. Distance  $20\frac{1}{2}''$ . There is a very obscure star of the third class near the last of the three, in the obscure star of the cross. Other five stars are dispersed about the quintuple one.

Between  $\beta$  and  $\zeta$  *Dolphin*, but nearer to  $\delta$ . All the three stars are whitish red, and nearly equal. Distance of the two nearest with a power of 278,  $21\frac{1}{2}''$ .

Near 27 *Cepheus*, near  $\delta$ . The distance of the two nearest of this treble star is about  $20''$ .

$\beta$ , or 10 *Lyra* (of the third magnitude, and about  $7^{\circ}$  south-east of the bright star *Vega*). The stars of this quadruple star are all white, the second, third, and fourth, inclining to red. The first and second are considerably unequal; the first and third very unequal; and the first and fourth unequal. Distance of the first and second,  $44''$ .

$\epsilon$ , or 78 *Geniæ* (Pollux). The stars of this multiple star are extremely unequal. The nearest distance is  $1' 57''$ ; the next distance is  $3' 17''$ .

In the *Umicorn's head*. This multiple star consists of one star with about twelve around it  $16^{\circ}$  west of *Procyon*.

$\zeta$ , or 16 *Cancer*. This very minute treble star requires very favorable circumstances to be distinctly seen. The two stars of which the preceding one consists are considerably unequal. The largest of these is larger than the single star, and the least of the two is less than the single star. The first and second largest and pretty

\* As the following and similar lists are inserted for the purpose of reference to amateur observers, the general reader, if he think proper, may pass over such lists and descriptions.



unequal, and the second and third pretty unequal. The two nearest are pale red. They are just separated with a power of 278, and with 469 their distance is  $\frac{1}{4}$  the diameter of the smaller one. *Zeta* Cancri is situated about 12 or 13 degrees south-east of Pollux, nearly in a line parallel to that which joins Castor and Pollux, and nearly the same distance north by east from Procyon. It appears as a star of the fifth or sixth magnitude, and is sometimes distinguished by the name of *Tequinc*. As a double star it is easily distinguished by a power of 140, with a 3 $\frac{1}{2}$  foot achromatic telescope, whose aperture is 2 $\frac{3}{4}$  inches, and might perhaps be seen with a power of 100. But it requires a much higher power to distinguish it as a treble star.

Most of the above stars may be found by consulting large planispheres of the heavens, or a common celestial globe. To facilitate the finding out of their positions, I have inserted in the above list some special directions, which may perhaps be of use to the astronomical tyro who is furnished with a moderately good telescope. It is to be regretted that, even on some of our latest 18-inch celestial globes, several of the stars above referred to are not distinctly marked, either with their number or with the Greek letters by which they are generally distinguished, and some of them are altogether omitted; such, for instance, as the celebrated star 61 *Cygni*, which is a double star, and whose proper motion is greater than that of any other star yet discovered in the heavens.

## CHAPTER X.

### ON THE MILKY WAY.

As we advance in our survey of the distant regions of the universe, the astonishing grandeur and extent of the sidereal heavens gradually opens to our view. We have hitherto considered only a few objects on the outskirts of the heavens, in respect to their distance, magnitude, and the wonderful complication of systematic motions which prevails among them. Had we no other objects to engage our attention, ages might be spent in contemplating and admiring the economy and magnificence of those starry groups which appear to the unaided eye on the nearer boundary of our firmament. But all that is visible to man's unassisted vision is as nothing when compared with the immensity of august and splendid objects which stretch themselves in boundless perspective toward infinity. The discoveries of modern astronomy have enlarged the sphere of our conceptions far beyond what could formerly have been surmised, and opened to view a universe boundless as its Creator, where human imagination is lost and confounded, and in which man appears like a mere microscopic animalculum, and his whole habitation as a particle of vapor when compared to the ocean. In contemplating the visible firmament with the unassisted eye, we behold only the mere portals, as it were, which lead to the interior recesses of the vast Temple of Creation. When we direct our views beyond these outer portals, by means of the most powerful telescopes, we obtain a view of some of its more magnificent porches, and a faint glimpse of those splendid apartments which we shall never be able to explore, but which lead us to form the most august conceptions of the extent and grandeur of what is concealed from our view. In entering this Temple, "not made with hands," the splendor of its decorations, the amplitude of its scale, and the awfulness of infinitude, forcibly strike the imagination. There is sufficient to awaken into exercise all the powers and feelings of devotion, and to excite us to fall down in humility and adoration before Him whose word spoke into existence this astonishing fabric, and "whose kingdom ruleth over all." These reflections may not appear altogether inappropriate when entering upon a description of the *Milky*

*Way*, which contains objects calculated to excite our highest admiration.

When we take a general view of the heavens about the months of August, September, and October, and during the winter months, we cannot fail observing a large, irregular, whitish zone stretching across the sky, with a few interruptions, from one end of the firmament to another. This mighty zone, thus stretching itself around us, is sometimes termed the *galaxy*, sometimes the *Via Lactea*, but more frequently, in plain English, the *Milky Way*, from its resemblance to the whiteness of milk. This luminous band is visible to every observer, and is the only real and sensible circle in the heavens. When traced throughout its different directions, it is found to encircle the whole sphere of the heavens, though in some parts of its course it is broader and more brilliant than in others. It forms nearly a *great circle* of the sphere, but it coincides neither with our equator, ecliptic, nor colures, nor with any other artificial circles which we conceive as drawn around the firmament. In all ages, so far as we know, this wonderful zone has retained the same position among the constellations as at the present day; and is frequently alluded to both by the astronomers and the poets of antiquity. Thus Ovid, on account of its luster, represents it as the high road to heaven, or the court of Jupiter:

"A way there is in heaven's extended plain,  
Which when the skies are clear is seen below,  
And mortals by the name of *Milky* know;  
The groundwork is of stars, through which the road  
Lies open to the Thunderer's abode."

And Milton, in his "Paradise Lost" alludes to it in these lines:

"A broad and ample road, whose dust is gold,  
And pavement stars, as stars to us appear;  
Seen in the galaxy, that Milky Way,  
Like to a circling zone powdered with stars."

This zone may be traced in the heavens as follows:—Beginning near the northern quarter of the heavens, at the head of Cepheus, or about 30° from the north pole, we may trace it through Cassiopeia, Perseus, Auriga, part of Orion, and the feet of Gemini. At this last point it crosses the Zodiac, and proceeding southward across the

equinoctial into the southern hemisphere, it passes through the Unicorn and the middle of the ship Argo, where it is most luminous. It then passes through Charles's Oak, the feet of the Centaur, the Cross, the Altar, the tail of Scorpio, the bow of Sagittarius, and a part of Ophiuchus. Here it separates into two branches as it passes again over the Zodiac into the northern hemisphere. One branch runs through the tail of Scorpio, the bow of Sagittarius, the shield of Sobieski, the feet of Antinous, Aquila, Delphinus, the Arrow, and the Swan. The other branch passes through the upper part of the tail of Scorpio, the side of Serpentarius, Taurus, Poniatowski, the Goose, and the neck of the Swan, where it again unites with the other branch, and passes on to the head of Cepheus, the place of its beginning. After sending off the two branches above-mentioned, they unite again after remaining separate for the space of more than 100 degrees. There is another small separation of the Milky Stream between Cassiopeia and Perseus. The two streams appear to leave a blank about the head of Perseus, and a considerable space on each side of it, to the extent of about thirty degrees in length, and three in breadth, and are again joined into one stream in the sword of Perseus, adjacent to Cassiopeia.\*

From the above description it will appear that the form, breadth, and general appearance of this zone are various in different parts of its circuit round the heavens. In some places it appears dense and luminous, in others faint and scattered; in certain points it appears broad, and in others narrow. Its breadth in some places, as between Auriga and Perseus, is only about four or five degrees; in other places, as in the southern parts of Scorpio, Ara, and the Cross, its breadth is from ten to fifteen or eighteen degrees. It assumes the appearance of a double path from the tail of the Scorpion, through the bow of Sagittarius, Antinous, Aquila, Taurus, Poniatowski, the Goose, and part of the Swan. It is more or less visible at every season of the year; but in Britain and in other northern latitudes it is most conspicuous during the months of August, September, and October, the latter part of July, and the beginning of November. About the middle of August, at nine o'clock in the evening, it may be seen stretching in an oblique direction over the heavens, from north-east to south-west, and its apparent motion along the heavens may be traced along with that of the other constellations. At other seasons of the year, and at other hours of the night, its position and form will appear somewhat different. It appears most brilliant in the southern hemisphere, particularly in the neighborhood of Argo, Ara, and the splendid constellation of the Cross. Between the tropics, where the atmosphere is clear and serene, it appears most vivid and brilliant. Mr. Brydon informs us that, from the top of Etna, it appeared "like a pure flame that shot across the heavens."

The ancients seem to have conjectured that the whiteness of this zone was owing to a confluence of stars; for Ovid, in the lines above quoted says "Its groundwork is of stars." Soon after the invention of the telescope this conjecture was confirmed, and astronomers were astonished at the number of stars which appeared in this bright zone of the heavens; and their number appeared to be increased in proportion to the magnifying powers of their telescopes. But it was not before Sir W. Herschel applied his powerful instruments

to this region of the heavens that its profundities were explored, and all its minute nebulous parts shown to consist of countless myriads of stars, of every apparent magnitude, stretching onward to the regions of infinity, until they appeared to be lost to the view, even when assisted by the largest telescopes. On first presenting telescopes of considerable power to this splendid zone, we are lost in amazement at the number, the variety, and the beautiful configurations of the stars of which it is composed. In certain parts of it every slight motion of the telescope presents new groups and new configurations, and the new and wondrous scene is continued over a space of many degrees in succession. In several fields of view, occupying a space not much more than twice the breadth of the moon, you perceive more of these twinkling luminaries than all the stars visible to the naked eye throughout the whole canopy of heaven. You seem to penetrate, as it were, to the remoter boundaries of creation, and feel bewildered and lost amidst the immensity of the universe. I have never been inspired with higher ideas of grandeur and sublimity, nor felt deeper emotions of humility and reverence, than when occasionally contemplating this stupendous scene through telescopes of considerable brilliancy and power. There is not another scene in creation, open to the view of mortals, calculated to fill the soul with more august conceptions, or to inspire it with more profound admiration and awe. In such surveys we behold "new heavens" and other firmaments rising to view, whose distances baffle the utmost stretch of imagination.

"O what a confluence of ethereal fire  
From suns unnumbered down the sleep of heaven  
Streams to a point and centers on my sight."

The following contains a brief summary of Sir W. Herschel's observations on this region of the heavens, made with a Newtonian reflecting telescope of twenty feet focal length and an aperture of eighteen inches. He found that this instrument completely resolved all the whitish appearances into stars, which the telescopes he formerly used had not light enough to do. The portion he first observed was that about the hand and club of Orion, and he found in this space an astonishing number of stars, whose number he endeavored to estimate by counting many fields, that is, the apparent space in the heavens he could see at once through his telescope, and computing from a mean of these how many may be contained in a given portion of the milky way. In the most vacant place to be met with in that neighborhood he found 63 stars; other six fields contained 110, 60, 70, 99, 70, and 74 stars, a mean of all which gave 79 for the number of stars to each field; and then he found that, by allowing fifteen minutes for the diameter of his field of view, a belt of fifteen degrees long and two broad, which he had often seen pass through his telescope in an hour's time, could not contain less than 50,000 stars, large enough to be distinctly numbered; beside which he suspected twice as many more, which could be seen only now and then, by faint glimpses, for want of sufficient light. The reader may acquire some conceptions of this immense number of stars occupying so small a space, if he consider that it is fifty times more than all the stars which the naked eye can discern at one time throughout the whole heavens, and that the space they occupy is only the 1-1575th part of the visible canopy of the heavens; so that if every part of the firmament were equally rich in stars, there would be within the reach of

\* See the direction of this zone in the map of the stars on Mercator's projection.

such a telescope as Herschel's no less than 68,750,000, or sixty-eight millions, seven hundred and fifty thousand stars. And we are further to consider that it was only in the comparatively "vacant places" of this zone that the number of stars above stated were perceived.

In some of his observations of other parts of this zone, Sir W. Herschel informs us that he described a much greater number of these luminaries in a similar extent of space. "In the most crowded parts of the Milky Way," he says, "I have had fields of view that contained no fewer than 588 stars, and these were continued for many minutes, so that in one quarter of an hour's time there passed no less than 116,000 stars through the field of view of my telescope." In order to appreciate this description, we are to suppose the telescope to have been fixed in one position at the time of observation, and that by the diurnal motion of the earth, or the apparent motion of the heavens, the first field of stars was gradually carried out of view, and other fields appeared in succession, until, in the space of fifteen minutes of time one hundred and sixteen thousand stars passed over the field of vision. Now, the field of view taken in by the telescope was only 15' of a degree, a space which is less than the *one-fourth* part of the apparent size of the moon. In this narrow field were seen about as many stars as are generally beheld throughout the whole sky by the naked eye in a clear winter's night; for although nearly a thousand stars might be seen by a very acute eye in a clear atmosphere, yet there are few persons that in our climate could distinctly recognize above 600 or 700 stars even in a clear night. At another time, this indefatigable astronomer perceived no less than two hundred and fifty-eight thousand stars pass before his view in the course of forty-one minutes. In the space between  $\epsilon$  and  $\gamma$  of the Swan, the stars are found clustering with a kind of division between them, so that they may be considered as clustering toward two different regions. In this space, taking an average breadth of about five degrees of it, he found from observation that it contains more than 331,000 stars, which gives above one hundred and sixty-five thousand for each clustering collection.

Supposing the Milky Way to be, on an average, twelve degrees broad, the whole of it will contain an area of 4320 degrees =  $12 \times 360$ . Now, if the space examined by Herschel between *Beta* and *Gamma* of the Swan be about fourteen degrees in length and five degrees in breadth, it will contain an area of seventy degrees, which is somewhat less than the 1-61st part of the space occupied by the Milky Way. Were we to suppose every part of this zone equally rich in stars as the space now referred to, it will contain no less than 20,191,000 stars, or more than twenty thousand times the number of those which are visible to the naked eye. The whole visible heavens, considered as a spherical plane, contains an area of 41,253 degrees. Now, could we suppose every portion of the firmament to be equally well replenished with stars as the milky zone, there would be more than 195,000,000\* of stars in the heavens discernible by such a telescope as Herschel's; but as there are comparatively few other regions of the heavens so densely crowded with stars as the Milky Way, we must make a certain abatement from this estimate, though it is probable there are more than one hundred millions of stars within the reach of our best instruments

were all the spaces of our firmament thoroughly explored; and future generations, with more powerful telescopes, may add indefinitely to the number. Had we taken the most crowded field of stars which Herschel perceived through his telescope (namely, 588) as our standard for estimating their number, the amount of stars in the Milky Way would have been forty millions, and in the whole heavens, 388 millions. In short, to use the words of Sir John Herschel—"This remarkable belt, when examined through powerful telescopes, is found (wonderful to relate!) to consist entirely of stars scattered by millions, like glittering dust, on the black ground of the general heavens."

In regard to the *distances* of some of these stars, we may easily conceive that they are immense, and consequently far removed from our distinct comprehension. Sir W. Herschel, in endeavoring to determine a "*sounding line*," as he calls it, to fathom the depth of the stratum of stars in the Milky Way, endeavors to prove, by pretty conclusive reasoning, that his twenty feet telescope penetrated to a distance in the profundity of space not less than 497 times the distance of Sirius; so that a stratum of stars amounting to 497 in thickness, each of them as far distant beyond another as the star Sirius is distant from our sun, was within the reach of his vision when looking through that telescope. Now, the least distance at which we can conceive Sirius to be from the earth or the sun is 20,000,000,000,000, or twenty billions of miles; and consequently the most distant stars visible in his telescope must be four hundred and ninety-seven times this distance, that is, 9,340,000,000,000,000, or nearly ten thousand billions of miles! Of such immense distance, it is evident we can form nothing approaching to a distinct conception. We can only approximate to a rude and imperfect idea by estimating the time in which the swiftest bodies in nature would move over such vast spaces. Light, which is endowed with the swiftest degree of motion yet known, and which flies at the rate of nearly twelve millions of miles every minute, would require one thousand six hundred and forty years before it could traverse the mighty interval stated above; and a cannon ball, flying at the rate of 500 miles an hour, would occupy more than 2,267,855,068, or two thousand, two hundred and sixty-seven millions, eight hundred thousand years, in passing through the same space!—a period of years before which all the duration that has passed since man was placed on this globe appears only like a few fleeting hours, or "as an handbreadth or a span."\*

\*The celebrated Schroeter, of Lilienthal, was a frequent observer of the stars which crowd the Milky Way. He was in the habit of observing with one of the largest reflecting telescopes to be found in Europe. This telescope was one of the finest ever constructed, and was the workmanship of Professor Schroder, of Kiel. The diameter of the speculum was about nineteen inches; it was about two inches in thickness, and toward the edge cast conical, so that the diameter of the polished surface is almost a quarter of an inch less than at the back, which circumstance was considered of the greatest utility in the finishing and polishing. It had a focus of twenty-six feet, and, without the frame, weighed eighty pounds. The large octagonal tube was constructed with boards, made impenetrable to rain; and the instrument when ready for use was twenty-seven feet long. An immense quantity of apparatus and machinery was requisite for steadying and moving it. The figure of the speculum was so perfect, that it could bear a power of 800 or 1000 times without diminishing the aperture. Its capability of resolving the nebulousity of the Milky Way seems to have equaled that of the telescopes of Herschel. He allowed twenty degrees of its length from a Cygnus to pass through the field, and the sight drew from him the natural exclamation, "What Omnipotence!" The power on the telescope in such observations was 179, and the diameter of the field, fifteen minutes; and the number of stars it contained at

\*  $4\frac{1}{4} \times 2\frac{5}{10} \times 3 \times 5 \times 8\frac{9}{10} \times 23 \times 331,000 = 195,067,757$

Here, then, let us pause for a moment, and consider the august spectacle presented to view. We behold a few whitish spaces in the firmament, almost overlooked by a common observer when he casts a rude glance upon the evening sky; yet in this apparently irregular belt, which appears only like an accidental tinge on the face of the firmament, we discover, by optical instruments, what appears to be an amazing and boundless universe. We behold not only ten thousands, but millions of splendid suns, where not a single orb can be perceived by the unassisted eye. The distance at which these luminous globes are placed from our abode is altogether overwhelming; even the most lively imagination drops its wing when attempting its flight into such unfathomable regions. The scenes of grandeur and magnificence connected with such august objects are utterly overwhelming to such frail and limited beings as man, and perhaps even more exalted orders of intelligences may find it difficult to form even an approximate idea of objects so distant, so numerous, and so sublime.

On our first excursions into the celestial regions we are almost frightened at the idea of the distance of such a body as Saturn, which a cannon ball projected from the earth, and flying with its utmost velocity, would not reach in 180 years.—We are astonished at the size of such a planet as Jupiter, which could contain within its circumference more than a thousand globes as large as the earth. We are justly amazed at the stupendous magnitude of the sun, which is a thousand times the size of Jupiter, and which illuminates with its splendor a sphere of more than five thousand millions of miles in circumference. But what are all such distances and dimensions, vast and amazing as they are, compared with the astonishing grandeur of the scene before us? They sink into comparative insignificance, and are almost lost sight of amidst the myriads of splendid suns which occupy the profundities of the Milky Way. What is *one* sun and *one* planetary system in the presence of *ten millions* of suns perhaps far more resplendent, and of a hundred times this number of spacious worlds which doubtless revolve around them? Yet this scene, stupendous as it is, is not the universe. It is perhaps, as we shall see, only a comparatively small corner of creation, which beings at an immensely greater distance will behold as an obscure and scarcely discernible speck on the outskirts of their firmament; so that amidst this vast assemblage of material existence we may say, in the language of the inspired prophet, when speaking of the Almighty, that *even here* is but “the hiding of his power.”—What then must the whole of creation be? and what must be the ineffable splendor and majesty of Him who laid the plan of the mighty fabric, whose breath kindled so many millions of suns, whose hands set in motion so many myriads of rolling worlds, who supports them in their ample and diversified courses, and whose moral government extends over all? And what is man, and the globe on which he dwells, amidst this scene of immensity and magnificence?—an atom in the infinity of space—a particle of vapor compared to the ocean—a being who in respect to the magnificence of creation and the grandeur of his Creator, is “as nothing, and is counted to him as less than nothing and vanity.”

Yet, amidst all the magnificence of this vast system of universal nature, man is not forgotten by his Maker; his hand supports him, his wisdom guides him, and his overflowing goodness provides, in a thousand different modes, for his happiness and enjoyment. He shares of the Divine beneficence and care in common with all the bright intelligences that people the amplitudes of creation, and is as amply provided for as if the Almighty had no other world under his superintendence. Within the moral government of the Creator of the universe he may rest secure and confident that he is not overlooked amidst the immensity of being, for his presence pervades the infinity of space, and his knowledge extends to the minutest movements of all his creatures.—Under his paternal care, not only man, but the crawling worm, the fluttering insect, the little ant, and even the microscopic animalculum, find a home and provisions, as well as the highest order of his creatures; for “he openeth his hand and supplieth the wants of every living being.”

Notwithstanding the size of the Milky Way, and the immense number of stars of which it is composed, it is now considered as nothing more than *one of the nebulae*, or stary systems, which appear to be dispersed throughout the universe. It is supposed, and with some reason, that it is the nebula or assemblage of stars, in which our sun is placed. Its situation in this nebula is reckoned to be, not in the center of its thickness, but rather toward one of the sides, near the point where it diverges into two branches. According to this hypothesis, the Milky Way is to be considered as the projection of the nebula upon the concave surface of the sky, as seen from a point within it. “We gather this,” says Sir W. Herschel, “from the appearance of the galaxy, which seems to encompass the whole heavens, as it certainly must do if the sun is within the same; for suppose a number of stars arranged between two parallel planes indefinitely extended every way, but at a given considerable distance from one another, and calling this a sidereal stratum, an eye placed somewhere within it will see all the stars in the direction of the planes of the stratum projected into a great circle, which will appear lucid on account of the accumulation of the stars, while the rest of the heavens at the sides will only seem to be scattered over with constellations, more or less crowded, according to the distance of the planes or number of stars contained in the thickness or sides of the stratum.”

Thus if the solar system be supposed at *S*, in the middle of the nebula *a b c d e f*, with two branches, *a c, b c* (fig. 28), the nebula will be projected into a circle *A B C D*, the arches *A B C, A E C*, being the projection of the branches *a c, b c*, while the stars near the sides of the stratum will be seen scattered over the remaining part of the heavens among the spaces *F, I, H, K, G*. If the eye were placed somewhere without the stratum, at no very great distance, the appearance of the stars within it would assume the form of one of the lesser circles of the sphere, which would be more or less contracted according to the distance of the eye; and if this distance were exceedingly increased, the whole stratum might at last be drawn together into a lucid spot of any shape, according to the position, length and height of the stratum.

In order to determine those points, Sir W. Herschel put in practice a method which he calls *gauging the heavens*, which consists in repeatedly counting the number of stars in the fields of view very near each other, by which he obtained a

once could never be counted. They were never estimated at less than fifty or sixty, and often reached or exceeded 150. He calculated that the number of stars visible through this telescope could not be less than 12,000,000.

mean of the number of stars in that part of the heavens. He then proceeds on the supposition that the stars are equally scattered, and from the number of stars in any part of the heavens he

Fig. 38.

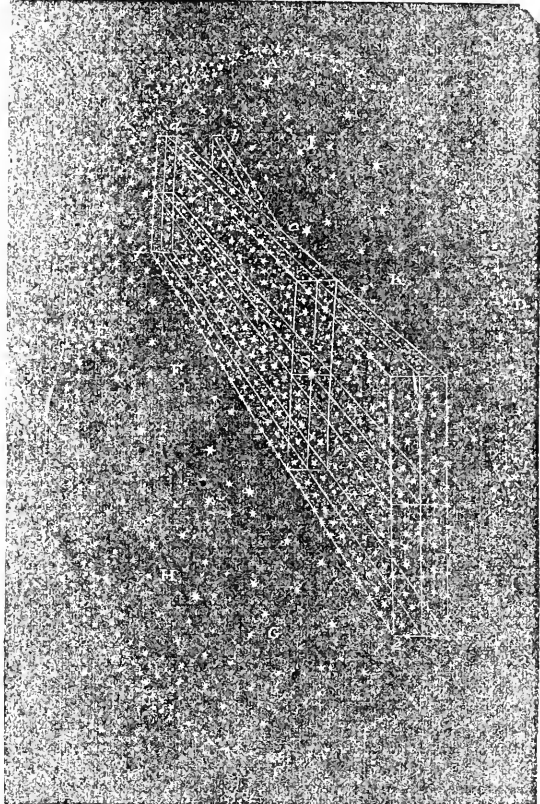

deduces the length of his visual ray, or the distance through which his telescope had penetrated, or, in other words, the distance of the remotest stars in that particular region of the heavens. To illustrate this, let us suppose the Milky Way a nebula, and that the sun is not placed in its center. Then, on the supposition that the stars are nearly equally scattered, it is evident that the part of the Milky Way where the stars are the most numerous extend furthest from the sun, and the parts where they are less numerous must extend to a less distance. Proceeding on these grounds, Sir W. Herschel found the length of his visual ray for different parts of the heavens. In some cases he found it equal to 497 times the distance of Sirius, supposed to be the nearest star, as formerly stated. The following is a representation of a section of the nebula of the Milky Way, according to his delineation. This section is one which makes an angle of thirty-five degrees with our equator, crossing it in  $121\frac{1}{2}$  and  $304\frac{1}{2}$  degrees. A celestial globe adjusted to the latitude of fifty-five degrees north, and having  $\sigma$  Ceti near the meridian, will have the plane of this section pointed out by the horizon. If the solar system (fig. 39), be at S, the brightness of the Milky Way will be greatest in the directions S a, S b, S p, where the stars that intervene are most numerous, or where the visual ray is longest. In the lateral directions S n, S m, the nebulosity will not appear from the small number of interposing stars, and the stars, though numerous, will appear more scattered. In the direction S c, on account of the opening between a and b, there will be an empty space contained between these two branches where the nebulosity is not observed, as is the case in the Milky Zone between  $\mu$  Scorpio in the south and  $\gamma$  Cygni in the north, a length of about 102 degrees. The stars in the border, which are marked larger than the rest, are those pointed out by the gauges; the intermediate parts are filled up by smaller stars arranged in straight lines between the gauged ones. The circle around S represents an extent about forty times the distance of the nearest fixed stars, which may be considered as comprehending all those which are visible to the naked eye.

"From this figure," says Sir W. Herschel, "we may see that our nebula is a very extensive branching, compound congeries of many millions of stars, which most probably owes its origin to many remarkably large, as well as pretty closely scattered small stars that may have drawn together the rest." Again—"If it were possible to distinguish between the parts of an indefinitely extended whole, the nebula we inhabit might be said to be one that has fewer marks of antiquity than any of the rest. To explain this idea more clearly, we should recollect that the condensation of clusters of stars has been ascribed to a gradual approach; and whoever reflects on the number of ages that must have passed before some of the clusters that are to be found in my intended catalogue could be so far condensed as we find them at present, will not

wonder if I ascribe a certain air of youth and vigor to very many regularly scattered regions of our sidereal stratum. There are, moreover, many places in it in which, if we may judge from some appearances, there is the greatest reason to believe that the stars are drawing toward secondary centers, and will in time separate into clusters so as to occasion many subdivisions. Our system, after numbers of ages, may very possibly become divided so as to give rise to a stratum of two or three hundred nebulae; for it would not be difficult to point out so many beginning or gathering clusters in it. This throws considerable light upon that remarkable collection of many hundreds of nebulae which are to be seen in what I have called the *nebulous stratum* in Coma Berenices. It appears from the branching and extended figure of our nebula, that there is room for the decomposed small nebulae of a large reduced former great one to approach nearer to us in the sides than in any other parts." . . . "Some parts of our system seem indeed already to have sustained greater ravages of time than others, for instance, in the body of the Scorpion is an opening or hole, which is probably owing to this cause. It is at least four degrees broad, but its height I have not yet ascertained. It is remarkable that the 80th nebula of the *Connaissance des Temps*, which is one of the richest and most compressed clusters of small stars I remember to have seen, is situated just on the west border of it, and would almost authorize a suspicion that the stars of which

it is composed were collected from that place, and had left the vacancy.

Fig. 39.

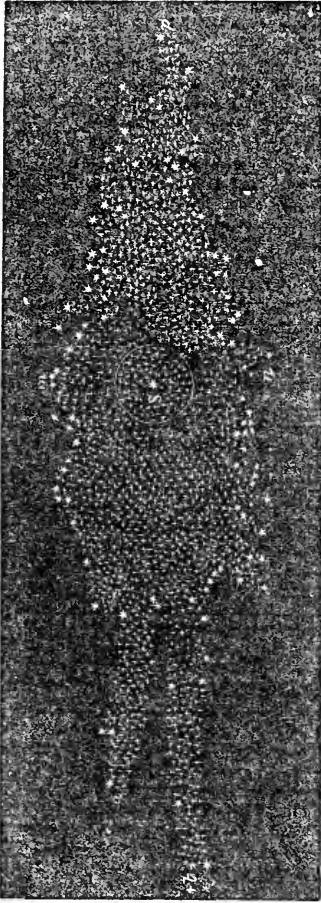

The remarks in the above paragraph I present to the reader merely as the opinions of an illus-

trious astronomer and an indefatigable observer of celestial phenomena, without vouching for the accuracy or probability of such speculations and hypotheses. To determine the reality of such changes in bodies so numerous and so distant, would require an indefinite lapse of ages; yea, perhaps the revolutions of eternity are alone sufficient for determining the sublime movements and changes which happen among the immense assemblages of material existence which constitute the universe. There is a high degree of probability that everything within the material system is liable to change of one kind or other, and that there is no sun nor world, among all the myriads of globes which replenish the sidereal heavens, but what is *actually in motion*,—and moving, too, with a velocity which the inhabitants of such a world as ours can scarcely appreciate; and such motions, in the course of ages, may be productive of a vast diversity of scenery in different regions of the universe. And if so, it presents to view another instance of that *variety* which the Creator has introduced into his universal kingdom to gratify the unbounded desires of intelligent beings.

I shall conclude this chapter with the following description of the Milky Way, which Sir John Herschel has published since his residence in the southern hemisphere:—"The general aspect of the southern circumpolar region—including in that expression sixty or seventy degrees of south-polar distance—is in a high degree rich and magnificent, owing to the superior brilliancy and larger development of the Milky Way, which from the constellation of Orion to that of Antinous is a blaze of light, strangely interrupted, however, with almost starless patches, especially in Scorpio, near  $\alpha$  Centauri, and the Cross; while to the north it fades away pale and dim, and is in comparison hardly traceable. I think it is impossible to view this splendid zone, with the astonishingly rich and evenly distributed fringe of stars of the third and fourth magnitudes—which form a broad skirt to its southern border, like a vast curtain—without an impression, amounting almost to a conviction, that the Milky Way is not a mere stratum, but an *annulus*; or at least that our system is placed within one of the poorer or almost vacant parts of its general mass, and that eccentrically, so as to be nearer to the parts about the Cross than to that diametrically opposed to it."

## CHAPTER XI.

### ON GROUPS AND CLUSTERS OF STARS.

On a cursory view of the heavens, the stars appear to be very irregularly scattered over the concave of the firmament. In some places a considerable interval appears between neighboring stars, while in others they appear so crowded that the eye can with difficulty perceive the spaces between them. Even to the unassisted eye, there are certain groups of this description which strike the attention of every observer, and lead to the conclusion that the stars of which they are composed have been brought together by some general law, and not by mere casual distribution. Of these, the group called the *Pleiades*, or Seven Stars, is the most obvious to common observers. This group is situated in the constellation Taurus, about  $14^{\circ}$  to the west of the star Aldebaran (see

Plate I), and may be seen every clear evening from the end of August until the middle of April.\* It is generally reckoned that only *six* stars can be distinctly counted in this group by common eyes, but that originally they consisted of *seven*, which every one could easily perceive, and it has therefore been conjectured that one of them has long since disappeared. To this circumstance Ovid, who lived in the time of our Saviour, alludes in these lines:

"Now rise the *Pleiades*, those nymphs so fair,  
Once seven numbered, now but six there are.†"

In fabulous history it is said that the *Pleiados*

\* A telescopic view of the *Pleiades* is exhibited in the Appendix.

† "Quæ septem dici, sex tamen esse solent."

the star Merope, one of the Atlantides, appears more dim and obscure than the rest, or is altogether extinguished, because, as the poets fancy, she married a mortal, while her sisters married some of the gods or their descendants. Dr. Long, however, declares that he himself had more than once seen seven stars in this group; and a learned astronomical friend assured him that he had seen eight stars among the Pleiades, where common eyes can discover but six; and Kepler says of his tutor Mæstlinus, that "he could reckon fourteen stars in the Pleiades without any glasses." This difference in the number seen by different persons in this group is obviously owing to the different degrees of acuteness of vision possessed by the respective individuals. However small the number perceived by the naked eye, the telescope shows them to be a pretty numerous assemblage. Dr. Hook, formerly professor of geometry in Gresham College, informs us that, directing his twelve-foot telescope (which could magnify only about seventy times) to the Pleiades, he did in that small compass count seventy-eight stars; and making use of longer and more perfect telescopes, he discovered a great many more of different magnitudes.

The ingenious Mr. Mitchell, more than fifty years ago, started the idea of the stars being formed into groups or systems which are entirely detached from one another, and have no immediate connection. In reference to the Pleiades, he conducted his reasoning as follows:—"The Pleiades are composed of six remarkable stars, which are placed in the midst of a number of others that are all between the third and sixth magnitudes; and comparing this number six with the whole number visible in the heavens to the naked eye, he calculated, by the doctrine of chances, that among all this number, if they had been dispersed arbitrarily through the celestial vault, it was about five hundred millions to one that six of them should be placed together in so small a space. It is therefore so many chances to one that this distribution was the result of design, or that there is a reason or cause for such an assemblage."

The constellation called *Coma Berenices* is another group, more diffused than the Pleiades, which consists chiefly of small stars which can scarcely be distinguished in the presence of the moon. This beautiful cluster lies about five degrees east of the equinoctial colure, and midway between the star *Cor Caroli* on the north-east, and *Denebola*, in the Lion's tail, on the south-west. If a straight line be drawn from *Benetnasch*—the star at the extremity of the tail of the Great Bear—through *Cor Caroli*, and produced to *Denebola*, it will pass through this cluster. It may also be distinguished as situated about twenty-six degrees west by north from the bright star *Arcturus*. The confused luster of this assemblage of small stars bears a certain resemblance to that of the Milky Way, and, beside the stars of which it is chiefly composed, it contains a number of nebulae. Sir W. Herschel supposes that the stratum of nebulae in this quarter runs out a very considerable way, and that it may even make the circuit of the heavens, though not in one of the great circles of the sphere. He also supposes that the situation of the stratum is nearly at right angles with the great sidereal stratum in which the sun is placed, that the *Coma* itself is one of the clusters in it, and that it is on account of its nearness that it appears to be so scattered. He apprehends that the direction of it toward the north lies probably, with some windings, through the Great Bear onward to *Cassiopeia*, thence through

the girdle of *Andromeda* and the Northern Fish, proceeding toward *Cetus*; while toward the south it passes through the *Virgin*, probably on to the tail of *Hydra* and *Centaurus*.

Another group, somewhat similar, but less definite, is found in the constellation of *Cancer*; it is called *Præsepe*, or the Bee Hive, and is a nebulous cluster of very minute stars, not separately distinguishable by the naked eye. A telescope of very moderate power, however, easily resolves it into small stars. It is sufficiently luminous to be seen as a nebulous speck by the unassisted eye, and is somewhat like the nucleus of a comet, for which it has frequently been mistaken by ordinary observers. It is situated in a triangular position with regard to *Castor* and *Procyon*, or the *Little Dog*. A line drawn from *Procyon* in a north-easterly direction meets with *Præsepe* at the distance of twenty degrees. This line drawn in a north-westerly direction from *Præsepe*, meets *Castor* at the same distance. These lines form nearly a right angle, the angular point being in *Præsepe*. It may otherwise be discovered by means of two stars of the fourth magnitude lying one on either side of it at the distance of about two degrees. It may likewise be found by conceiving a line drawn through *Castor* and *Pollux* to the south-east, and continued about fifteen degrees, or three times the distance between *Castor* and *Pollux*. This cluster, Sir W. Herschel thinks, belongs to a certain nebulous stratum so placed as to lie nearest us. This stratum runs from  $\epsilon$  *Canceri* toward the south, over the 67th nebula of the *Connoissance des Temps*, which is a very beautiful and much compressed cluster of stars, easily to be seen by any good telescope, and in which he has observed above 290 stars at once in the field of view of his great reflector, with a power of 157. This cluster appearing so plainly with any good common telescope, and being so near to the one which may be seen with the naked eye, denotes it to be probably the next in distance to that within the quartile formed by  $\gamma$  *Scorpii*. From the 67th nebula, the stratum of *Cancer* proceeds toward the head of *Hydra*.

I have seldom contemplated a more brilliant and beautiful view in the heavens than one of the fields of view of this cluster of stars. With a  $3\frac{1}{2}$  feet achromatic, and a power of 95, I have counted from fifty to seventy stars. Fifteen or twenty of the most brilliant of these presented beautiful configurations: one of them was an equilateral triangle; another, an isosceles; a third, nearly of the figure of a cone; a fourth, parallel lines, &c. In more than two instances, three brilliant equidistant stars appeared in a straight line, similar to the belt of *Orion*, while a considerable number of the remaining stars appeared extremely small. With a  $6\frac{1}{2}$  feet achromatic, whose object-glass is four inches diameter, and a power of 110, this view was rendered still more brilliant. Several fields of view, nearly of this description may be perceived in this cluster. Fig. 40 represents one of these views, in which some of the smaller stars are omitted. This view was taken with the  $3\frac{1}{2}$  feet telescope, having an erect eye-piece. The configurations appear somewhat different in their relations to each other when viewed with an inverting eye-piece.

Another cluster is found in the sword-handle of *Perseus*, which is crowded with stars of a smaller size than in the clusters already noticed, and which requires a telescope of greater power to resolve them and show them separated from each other. *Perseus* is one of the northern circumpolar constellations, nearly opposite to the three stars



in the tail of the Great Bear. A line drawn from these stars through the pole-star meets the sword and head of Perseus at nearly an equal distance on the opposite side. It is directly north of the Pleiades, between Andromeda and Auriga. The

Fig. 40.

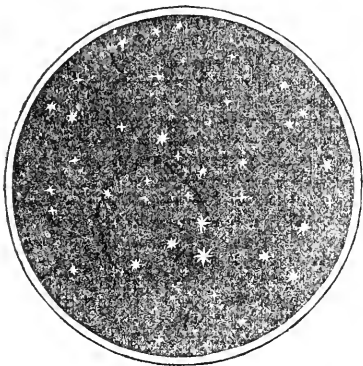

sword is in the neighborhood of Cassiopeia. A line drawn from *Algenib*, the brightest star in this constellation, to the middle of Cassiopeia, passes through the sword-handle where the cluster is situated, which is about midway between these two objects.

If the lowermost of the three small stars which form the *sword* of Orion be viewed with a good telescope, a beautiful configuration of stars will be perceived. Fig. 41 represents the principal

Fig. 41.

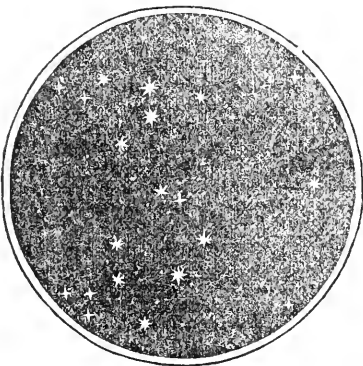

stars comprehended in one field of view at this point, as taken with a six feet and a half telescope, with an inverting eye-piece, magnifying 110 times; it exhibits a distant resemblance of the whole constellation of Orion as seen by the naked eye. But in the neighborhood of certain parts of the Milky Way, particularly about the regions in the vicinity of the star *Altair* and in the constellation Cassiopeia, the stars, though smaller, are much more numerous. With a very moderate power on the above-mentioned telescope, I have had fields of view of from fifty to a hundred stars, some of them beautifully arranged, and such fields continued over a space of several degrees.

The above may be considered as specimens of groups of stars, which every one possessed of telescopes may easily examine for himself. They form very beautiful objects for exhibiting to young

people and to amateurs in astronomy; and it cannot but strike the mind with wonder and admiration to behold, in one point of view, within a space little more than that of the *one-fifth* of the apparent size of the moon, nearly a hundred resplendent suns emitting their effulgence from regions immeasurably distant, and arranged in beautiful symmetry and order—a scene of creating power surpassing in grandeur ten thousand worlds such as ours, and in which our whole planetary system would appear only as the smallest twinkling star. Such telescopic views of the nocturnal heavens have a tendency to expand the capacity of the soul, to inspire it with magnificent conceptions, and to raise its affections above the low ambition and paltry concerns of this transitory scene to the distant and more magnificent scenes of the Divine empire. To the devout and contemplative philosopher the following lines of the poet may be applied:

“Not to this evanescent speck of earth  
Poorly confined—the radiant tracks on high  
Are his exalted range; intent to gaze  
Creation through, and from that ill complex  
Of never ending wonders to conceive  
Of the sole Being right, who spoke the word,  
And Nature moved complete.”

THOMSON'S *Summer*.

Sir W. Herschel makes a distinction between *groups* and *clusters* of stars. A group is a collection of stars closely and almost equally compressed, and of any figure or outline. There is no particular condensation of the stars to indicate the existence of a central force, and the groups are sufficiently separated from neighboring stars to show that they form peculiar systems of their own. According to this definition, the congeries of stars I have pointed out above are to be considered as belonging to the class of *groups*. *Clusters* of stars differ from groups in their beautiful and artificial arrangement. Their form is generally round, and their condensation is such as to produce a mottled luster somewhat resembling a nucleus. The whole appearance of a cluster indicates the existence of a central force, residing either in a body or in the center of gravity of the whole system. The stars of which it is composed appear more and more accumulated toward the center.

Many such clusters are found in the heavens invisible to the naked eye, and whose existence as dim specks of light can only be recognized by the assistance of optical instruments. Telescopes of moderate power exhibit them only as small round or oval specks, somewhat resembling comets without tails; but when these objects are examined with telescopes of great power, “they are then,” as Sir John Herschel remarks, “for the most part, perceived to consist entirely of stars crowded together so as to occupy almost a definite outline, and to run up to a blaze of light in the center, where their condensation is usually the greatest.” “Many of them, indeed, are of an exactly round figure, and convey the complete idea of a globular space filled full of stars, insulated in the heavens, and constituting in itself a family or society apart from the rest, and subject to its own internal laws. It would be a vain task to attempt to count the stars in one of these *globular clusters*. They are not to be reckoned by hundreds; and on a rough calculation, grounded on the apparent intervals between them at the borders (where they are seen not projected on each other) and the angular diameter of the whole group, it would appear that many clusters of this description must contain at least ten or twenty thousand stars, com-



packed and wedged together in a round space, whose angular diameter does not exceed eight or ten minutes—that is to say, in an area not more than a tenth part of that covered by the moon." The stars composing such clusters appear to form a system of a peculiar and definite character. "Their round figure clearly indicates the existence of some general bond of union in the nature of an attractive force, and in many of them there is an evident acceleration in the rate of condensation as we approach the center, which is not referable to a merely uniform distribution of equidistant stars through a globular space, but marks an intrinsic *density* in their state of aggregation, greater at the center than at the surface of the mass."

Let the reader pause for a moment on the object now described, and consider the glimpse it affords us of the immensity of the universe, and of the innumerable globes of light with which it is replenished. A point in the firmament, scarcely perceptible to the unassisted eye, which a common telescope shows only as a small dim round speck, yet is found by powerful instruments to consist entirely of stars to the number of *ten or twenty thousand!* And at what a distance must such a cluster be when its stars appear to be blended and projected one upon another, hundreds of them appearing only like a lucid point! and yet the distance between any two of them is perhaps ten thousand times greater than that of Saturn from our globe. From such a region even light itself must take many thousands of years ere it can reach our world. In this almost invisible point, which not one out of fifty thousand, or even one out of a million of earth's inhabitants has yet perceived, what a scene of grandeur and beneficence may be displayed; and what a confluence of suns, and systems, and worlds and intelligences of various orders, may exist, displaying the power and wisdom and goodness of the great Father of all! Every circumstance connected with such an object shows that its distance must be immeasurably great, and consequently the luminaries of which it is composed immense in magnitude. But suns of such size and splendor cannot be supposed to be thrown together at random through the regions of infinity, without any ultimate design worthy of the Creator, or without relation to the enjoyments of intelligent existence; and therefore we may reasonably conclude that ten thousand times ten thousands, and myriads of myriads of exalted intelligences exist in that far distant region, compared with the number of which all the inhabitants of our globe are but "as the drop of a bucket, or as the small dust of the balance."

In short, in this dim and almost imperceptible speck we have concentrated a confluence of suns and worlds, at least ten times surpassing in size and splendor the sun, moon, and planets, and all the stars visible to the naked eye throughout all the spaces of our firmament! What then must be the number and magnitude of all the other clusters which the telescope has brought to view? what the number of those which lie beyond the limits of human vision in the unexplorable regions of immensity? and what must the UNIVERSE itself be, of which all those numerous starry systems are but an inconsiderable part? Here the human faculties are completely lost amidst the immensity of matter, magnitude, motion, and intelligent existence, and we can only exclaim, "Great and marvelous are thy works, Lord God Almighty!"

Figure 41 represents a view of one of the clusters alluded to above, as seen in the twenty-foot

reflector at Slough. Sir J. Herschel, who has given a delineation of it in his "Treatise on Astronomy," says, "it represents, somewhat rudely, the thirteenth nebula of Messier's list, described by him as *nebulæ sans étoiles*." Its right ascension is 16h. 36'; and its north declination, 36° 46'; by which its place may easily be found on a celestial globe. It is situated on the constellation Hercules, between the stars  $\alpha$  and  $\zeta$ . These stars are of the third magnitude, and lie north and south of each other, at the distance of seven degrees and a third; they come to the meridian about the middle of July, at nine o'clock in the evening, but of course may be seen at many other periods of the year, particularly in the spring and autumn. The star  $\alpha$  lies about twenty-two degrees nearly due west from the bright star Vega or  $\alpha$  Lyra. In the map of the stars on Plate II, it is marked with the letter *a*, and the star  $\zeta$  below it with the letter *b*. The cluster is somewhat nearer to  $\alpha$ , or the upper star, than to the other. It is just perceptible to the naked eye, and with a telescope of small power, such as a common "night and day telescope," it appears like a small round comet.

The following is a list of the places of six of the principal clusters of this description, which may be considered as specimens of these remarkable objects:

1. Right ascension, 15h. 10'; north declination, 2° 44'. This cluster lies about eight degrees south-west from *Unuk*, the principal star in the Serpent, and comes to the meridian, about the middle of June, at nine o'clock in the evening.

2. Right ascension, 13h. 34'; north declination, 29° 15'; between the tail of Chara and the thigh of Bootes, about twelve degrees north-west of Arcturus, nearly on a line between that star and *Cor Caroli*, but nearer Arcturus.

3. Right ascension, 13h. 5'; north declination, 19° 5'; in Coma Berenices, fourteen degrees west by south of Arcturus. A line drawn from Arcturus through  $\alpha$  Bootes meets this cluster at somewhat more than double the distance of these two stars.

4. Right ascension, 17h. 29'; south declination, 3° 6'; between the stars  $\gamma$  and  $\mu$  of Serpentarius, but nearer to the latter.

5. Right ascension, 21h. 25'; south declination, 1° 34'; in Aquarius, about 2 degrees north of  $\alpha$  in the west shoulder, nearly in a line with  $\epsilon$  Pegasi or *Enif*.

6. Right ascension, 21h. 22'; north declination, 11° 26'. This cluster lies north from No. 5, at the distance of thirteen degrees, and about three or four degrees north-west of the star *Enif*, or  $\epsilon$  Pegasi.

Such are a few specimens of *compressed* clusters of stars. Sir W. Herschel has given a catalogue of more than a hundred of such clusters dispersed over different parts of the heavens, many of which require powerful telescopes to resolve them into stars. These clusters may be considered as so many distinct *firmaments*, distributed throughout the spaces of immensity, each of them comprising within itself an assemblage of stars far more numerous than what appears to the vulgar eye throughout the whole face of our nocturnal sky. To those intelligences that reside near the center of such clusters, the stars connected with their own cluster or system will be those which they will chiefly behold in their sky; and in those clusters which are of a globular form, the stars will appear nearly equally dispersed over the face of their firmament. In those starry assemblages which show a great compression about the center, an immense number of stars of the first magni-

tude will decorate their sky, and render it far more resplendent than that with which we are surrounded—another instance of that *variety* which distinguishes all the scenes of creation. Scarcely any other star will be visible except those which belong to their own system. If the magnificent system of stars with which our sun is

connected be at all visible, it will only appear like a dim and inconsiderable speck in the remote regions of immensity, or as a small cluster or nebula, such as those we perceive with difficulty through our telescopes. Such are the grand, the diversified, and wonderful plans of the Creator throughout his vast and boundless universe.

## CHAPTER XII.

### ON THE DIFFERENT ORDERS OF THE NEBULÆ.

#### SECTION I.

##### GENERAL REMARKS ON THE SUBJECT OF NEBULÆ.

THE farther we proceed in our researches into the sidereal heavens, the scene of Creating Power and Wisdom becomes more expansive and magnificent. At every step of our progress the prospect enlarges far beyond what we had previously conceived; the multitude and variety of its objects are indefinitely increased; new suns and new firmaments open to view on every hand, overwhelming the mind with astonishment and wonder at the immensity of Creation, and leaving it no room to doubt that, after all its excursions, it has arrived only at "the frontiers of the Great Jehovah's kingdom." Wherever we turn our eyes amid those higher regions, infinity appears to stretch before us on either hand, and countless assemblages of the most resplendent objects are everywhere found diversifying the tracts of immensity. To investigate such objects in relation to their number, magnitude, motion, and the laws by which they are united and directed in their movements, completely baffles the mathematician's skill, and sets all his hitherto acquired powers of analysis at defiance, and demonstrates that we are still in the infancy of knowledge and of being. Here, all finite measures fail us in attempting to scan such amazing objects, and to penetrate into such unfathomable recesses; length, breadth, depth, and height, and time and space, are lost. We are justly filled with admiration at the amazing grandeur of the Milky Way, where suns and worlds are counted by MILLIONS. When exploring its dimensions and sounding its profundities, we seem to have got a view of a universe far more expansive than what we had previously conceived to be the extent of the whole creation. But what shall we say if this vast assemblage of starry systems be found to be no more than *single nebula*, of which several thousands, perhaps even richer in stars, have already been discovered! and that it bears no more proportion to the whole of the sidereal heavens around us, than a small dusky speck which our telescopes enable us to descry! Yet such is the conclusion which we are led to deduce from the discoveries which have been lately made respecting the different orders of the nebulae, of which I shall now proceed to give a brief description.

The word *nebula* literally signifies a *cloud*, or mist. This name is now used in astronomy to denote certain small spots, resembling whitish clouds, which are seen in the starry heavens by the telescope, and which present different kinds of appearances; either that of single stars enveloped in a nebulous veil, or of groups of small

stars, or only the appearance of a shining or glittering cloud: which last are the nebulae properly so called. The following are some general observations on the Nebulae by Sir William Herschel. The success which accompanied the observations of this eminent astronomer in reference to the Milky Way, induced him to turn his telescope to the nebulous parts of the heavens, of which an accurate list had been published in the *Connoissance des Temps*\* for 1783 and 1784. Most of these yielded to a Newtonian reflector of 20 feet focal distance, and 12 inches aperture, which plainly discovered them to be composed of stars, or at least to contain stars, and to show every other indication of their consisting of them entirely.

"The nebulae," says he, "are arranged into strata, and run on to a great length; and some of them I have been able to pursue, and to guess pretty well at their form and direction. It is probable enough that they may surround the whole starry sphere of the heavens, not unlike the Milky Way, which undoubtedly is nothing but a stratum of fixed stars. And as this latter immense starry bed is not of equal breadth or luster in every part, nor runs on in one straight direction, but is curved and even divided into two streams along a very considerable portion of it, we may likewise expect the greatest variety in the strata of the clusters of stars and nebula. One of these nebulous beds is so rich, that in passing through a section of it, in the time of only thirty-six minutes, I have detected no less than thirty-one nebulae all distinctly visible upon a fine blue sky. Their situation and shape, as well as condition, seem to denote the greatest variety imaginable. In another stratum, or perhaps a different branch of the former, I have seen double and treble nebulae variously arranged; large ones with small, seeming attendants; narrow but much extended lucid nebulae or bright dashes; some of the shape of a fan, resembling an electric brush issuing from a lucid point; others of the cometic shape, with a seeming nucleus in the center, or like cloudy stars surrounded with a nebulous atmosphere. A different sort again contain a nebulosity of the milky kind, like that wonderful inexplicable phenomenon about  $\delta$  Orionis; while others shine with a fainter

\* *Connoissance des Temps*, or as it is sometimes written, *Connaissance des Temps*, literally signifies the *knowledge of time*. It is the title of an Almanac, or astronomical ephemeris, published at Paris, on nearly the same plan as the "Nautical Almanac," published at London. The following is the title of one published in the year 1785:—"Connaissance des Temps, ou des Movemens Celestes, à l'Usage des Astronomes et des Navigateurs, pour l'an 1788. Publiée par le Bureau des Longitudes." It contains 216 pages.

mottled kind of light, which denotes their being resolvable into stars."

"In my late observations on nebulae," says Sir William on another occasion, "I have found that I generally detected them in certain directions rather than in others; that the spaces preceding them were generally quite deprived of their stars, so as often to afford many fields without a single star in it; that the nebulae generally appeared some time after among stars of a certain considerable size, and but seldom among very small stars; and when I came to one nebula, I generally found several more in the neighborhood; that afterward a considerable time passed before I came to another parcel. These events being often repeated in different altitudes of my instrument, and some of them at considerable distances from each other, it occurred to me that the intermediate spaces between the sweeps might also contain nebulae; and finding this to hold good more than once, I ventured to give notice to my assistant at the clock that 'I found myself on nebulous ground.'" From these observations of Herschel, it appears that the nebulae are not dispersed indiscriminately through the heavens, but are found in certain regions and directions rather than in others, and that, as formerly stated, they probably make the circuit of the heavens, intersecting at a certain angle the Milky Way.

More than eighty years ago, it was suggested by the celebrated mathematician and astronomer, M. Lambert, in his "Letters on Cosmogony," that all the stars in the universe are collected into systems; that all the systems are in motion; that the individual stars or suns of each system move round a common center of gravity, which may possibly be a large opaque globe; and that all the systems of the universe, as one related system, revolve around some GRAND CENTER, common to the whole. "All those systems of worlds," says this astronomer, "resemble, though on a small scale, the solar system, inasmuch as in each the stars of which it is composed revolve round a common center, in the same manner as the planets and comets revolve round the sun. It is even probable that several individual systems concur in forming more general systems, and so on. Such, for example, as are comprehended in the Milky Way, will make component parts of a more enlarged system; and this way will belong to other milky ways, with which it will constitute a whole. If these last are invisible to us, it is by reason of their immense distance. It would not be at all astonishing, if milky ways, situated still farther from us in the depth of the heavens, should make no impression on the eye whatever." Again—"The sum of the milky ways, taken together, have their common center of revolution; but how far soever we may thus extend the scale we must necessarily stop at last; and where? At the center of centers, at the center of creation, which I should be inclined to term the capital of the universe, inasmuch as thence originates motion of every kind, and there stands the great wheel in which all the rest have their indentation. From thence the laws are issued which govern and uphold the universe, or, rather, there they resolve themselves into one law of all others the most simple. But who would be competent to measure the space and time which all the globes, all the worlds, all the worlds of worlds, employ in revolving round that immense body—the Throne of Nature and the Footstool of the Divinity! What painter, what poet, what imagination is sufficiently exalted to describe the beauty, the magnificence, the grandeur of this source of all that

is beautiful, great, magnificent, and from which order and harmony flow in eternal streams through the whole bounds of the universe."

The discoveries made by Sir W. Herschel in reference to the nebulae have in part realized some of the views suggested by Lambert in regard to the general arrangements of the systems of the universe. They afford convincing evidence that the stars are not dispersed as it were at random, in a kind of magnificent confusion, but are distributed systematically, in immense clusters, throughout the regions of boundless space.

There are various forms and classes of nebulae which we shall notice in the sequel, but they may all be reduced to two great classes,—the *resolvable* and *irresolvable*; that is, those which may be resolved into clusters of stars by powerful telescopes, and those which no telescope hitherto constructed has yet been able to resolve into starry groups.

Prior to Sir W. Herschel's observations on the nebulae, about a hundred of these objects had been described in different parts of the heavens, of which an account had been given by Messier, as formerly stated. About 2000 more were afterward discovered by the unwearied exertions of our British astronomer, a description of which was inserted at different periods in the Philosophical Transactions. The places of these were afterward computed from his observations, and arranged into a catalogue, in the order of right ascension, by his sister, Miss Caroline Herschel; a lady singularly eminent for her astronomical knowledge, who assisted him in all his sidereal labors and discoveries, and was herself a discoverer of several interesting celestial phenomena, particularly comets. Her illustrious nephew, Sir John Herschel, read a paper before the Royal Society in November, 1833, in which he gives the places of 2500 nebulae, or clusters of stars, of which 500 were detected by his own observations, the rest having been accurately determined by his father. Beside these, more than 500 nebulae have been discovered in the southern hemisphere of the heavens, of which the Magellanic clouds are the most conspicuous and the most remarkable. They are three in number, two of them being near each other; the largest is at a considerable distance from the south pole, but the other two are only eleven degrees distant. To the naked eye, they appear like portions of the Milky Way.

These nebulae have great variety of forms: some are comparatively bright, and others so obscure as to render it difficult to detect them in the field of the telescope, or to ascertain their shape. Some of them appear round, some oval, and others of a long elliptic shape; some exhibit an annular form, like luminous rings, and others like an ellipsis with a dark space in the center; but the greater number approximate to a roundish form. Of the 103 nebulae inserted in Messier's list, eighteen were known at the time to consist of small stars; but Sir W. Herschel afterward found twenty-six more of them to consist purely of clusters of stars, eighteen of small stars accompanied with nebulosity, and the remainder not resolvable into stars by the highest powers of his telescopes. It is evident that these objects, however apparently small and obscure, must be bodies of *immense magnitude*, when we take into consideration the vast distance at which they must be placed from our globe. The following are Sir W. Herschel's views on this point:

"My opinion of their size is grounded on the following observations:—There are many round nebulae of about five or six minutes in diameter,

the stars of which I can see very distinctly; and on comparing them with the visual ray calculated from some of my long gauges, I suppose, by the appearances of the small stars in those gauges, that the centers of these round nebulae may be 600 times the distance of Sirius from us." He then goes on to show that the stars in such nebulae are probably twice as much condensed as those of our system, otherwise the center of it would not be less than 6000 times the distance of Sirius, and that it is possibly much underrated by supposing it only 600 times the distance of that star. "Some of these round nebulae have others near them, perfectly similar in form, color, and the distribution of stars, but of only half the diameter; and the stars in them seem to be doubly crowded, and only at about half the distance from each other. They are indeed so small as not to be visible without the utmost attention. I suppose these miniature nebulae to be at double the distance from the first. An instance equally remarkable and instructive is a case where, in the neighborhood of two such nebulae as have been mentioned. I met with a third similar, resolvable, but much smaller and fainter nebula. The stars of it are no longer to be perceived; but a resemblance of color with the former two, and its diminished size and light, may well permit us to place it at full twice the distance of the second, or about four or five times the distance of the first; and yet the nebulosity is not of the milky kind, nor is it so much as difficultly resolvable or colorless. Now in a few of the extended nebulae, the light changes gradually, so as from the resolvable to approach to the milky kind; which appears to me an indication that the milky light of nebulae is owing to their much greater distance. A nebula, therefore, whose light is perfectly milky cannot well be supposed to be at less than six or eight thousand times the distance of Sirius; and though the numbers here assumed are not to be taken otherwise than as very coarse estimates, yet an extended nebula which in an oblique situation, where it is possibly foreshortened by one-half, two-thirds, or three-fourths of its length, subtends a degree or more in diameter, cannot be otherwise than of a wonderful magnitude, and may well OUTVIE OUR MILKY WAY IN GRANDEUR."

It appears to be a very natural conclusion, that the nebulae which are perfectly similar in form, color, and the distribution of stars, but only half the diameter, and the stars doubly crowded, are about double the distance from the first. And if the distance of the larger nebula, whose stars are distinctly seen, be at least 600 times the distance of Sirius, as there is every reason to believe, then, the distance of those which are only half the diameter must be about 1200 times the distance of that star; that is at the very least, 24,000,000,000,000,000, or twenty-four thousand billions of miles. But the nebulae whose light is "perfectly milky," or so far removed from us that the stars of which they are composed cannot be separately distinguished, may be justly considered as seven thousand times the distance of Sirius, or, in numbers, 168,000,000,000,000,000, or one hundred and sixty-eight thousand billions of miles!—a distance of which we can have no distinct conception. Light, notwithstanding its amazing velocity, would be nearly thirty thousand years ere it could fly from such nebulae to the earth, and a cannon ball, with its utmost velocity, would require more than thirty-eight thousand millions of years before it could move over an equal space. Since the distance of these nebulae is so immense, and since those which are amongst the largest and nearest

are found by actual observation to be composed of countless numbers of stars, leaving us no room to doubt that the most distant are also immense systems of stars, how great must be the magnitude, and how inexpressible the grandeur, of the numerous luminaries of which they are composed!

I have stated above that more than three thousand nebulae have already been discovered, and whose places in the heavens have been accurately determined, so that those who have access to powerful telescopes may have an opportunity of observing the greater part of them. From all the observations made by Sir W. Herschel, he is of opinion that our nebula, or the Milky Way, is not the most considerable in the universe; and he points out some very remarkable nebulae which in his opinion cannot be less, but are probably much larger, than that of which our own sun and system form a part. Now, on these grounds let us consider what must be the extent and magnitude of only the visible universe. Supposing the number of stars composing the Milky way, to be ten millions, which is only half the number formerly assigned, (p. 59), and that each of the nebulae at an average contains the same number; supposing further, that only two thousand of the three thousand nebulae are resolvable into clusters of stars, and that the other thousands are masses of a shining fluid not yet condensed into distinct luminous globes; the number of stars, or suns, comprehended in that portion of the firmament which is within the reach of our telescopes would be 20,000,000,000, or twenty thousand millions, which is twenty millions of times the number of all the stars visible to the naked eye.

Great as the number is, and magnificent and overpowering as the ideas are which it suggests of the extent of creation, yet these vast assemblages of systems may be no more than as a single nebula to the whole visible firmament, or even as a grain of sand to the whole earth, compared with what lies beyond the range of human vision, and is hid from mortal eye in the boundless and unexplored region of immensity! Beyond the boundaries of all that will ever be visible to the inhabitants of our globe, an infinite region exists, in which we have every reason to believe the Deity sits enthroned in all the grandeur of his overflowing goodness and omnipotence, presiding over innumerable systems far surpassing in magnificence what "eye hath yet seen" or the most brilliant intellect can conceive. For we ought never for a moment to surmise that the operations of Almighty Power are exhausted at the point where the efforts of genius and art can no longer afford us assistance in tracing the footsteps of the divinity through the mysterious regions of infinitude; nor should we ever suppose that man, placed on such a diminutive ball as the earth, and furnished with powers of so limited a nature as those with which he is now invested, will ever be able to grasp the dominions of Him who fills immensity with his presence, and "whose ways are past finding out."

## SECTION II.

### ON THE VARIOUS KINDS OF NEBULÆ.

I HAVE already alluded to the different shapes or forms of nebulae. These objects, on account of their appearing with different degrees of luster, and assuming a great variety of shapes and modifications, have been arranged into different classes

1. The first class is that of clusters of stars, in

which the separate stars are clearly distinguished by good telescopes. This class is again divided into *globular* clusters, or those which appear of a roundish form, and somewhat compressed toward the center; and *irregular* clusters or those which are neither circular nor elliptical, but of a somewhat indefinite or angular form. These last are generally less rich in stars, and less condensed toward the center, and are likewise less definite in their outline, so that their termination in many cases cannot be distinctly perceived. In some of them the stars are nearly all of the same size, in others extremely different; and "it is no uncommon thing," says Sir J. Herschel, "to find a very red star, much brighter than the rest, occupying a conspicuous situation in them." Sir W. Herschel regards these as globular clusters in a less advanced state of condensation, conceiving all such groups as approaching, by their mutual attraction, to the globular figure, and assembling themselves together from all the surrounding region, under laws of which we have no other proof than the observance of a gradation by which their characters shade into one another, so that it is impossible to say where one species ends and the other begins. Fig. 41, formerly referred to, represents one of the globular clusters in the constellation Hercules. Fig. 42 is a view of a curious but somewhat irregular group, seen in the southern hemisphere, as sketched by Mr. Dunlop, at Paramatta, New South Wales. It is the 30 Doradus, or Xipheas, and is rather a singular object, but evidently a large cluster of stars, presenting two or three very condensed strata, as if they were crowded to excess by an immense confluence of stars.

2. Another class that is termed *resolvable* nebulae, or those which lead us to suppose that they consist of stars which would be separately distinguishable by an increase of light and magnifying power in the telescope. These may be considered as clusters too remote to be distinctly seen, the stars composing which are either too faint in their light or too small in size to make a definite impression upon the organs of vision. They are almost universally round or oval, which is supposed to be owing to their loose appendages and irregularities of form being extinguished by their distance, the general figure of the central or more condensed parts being only discernible. "It is under the appearance of objects of this character," says Sir J. Herschel, "that all the greater globular clusters exhibit themselves in telescopes of insufficient optical power to show them well; and the conclusion is obvious that those which the most powerful can barely render *resolvable*, would be completely *resolved* by a further increase of instrumental force.

3. Beside the above, there is an immense variety of nebulae, *properly so called*, which no tele-

scopes have hitherto been able to resolve into stars, and which is supposed to be a species of matter diffused throughout infinite space, in various portions and degrees of condensation and which may

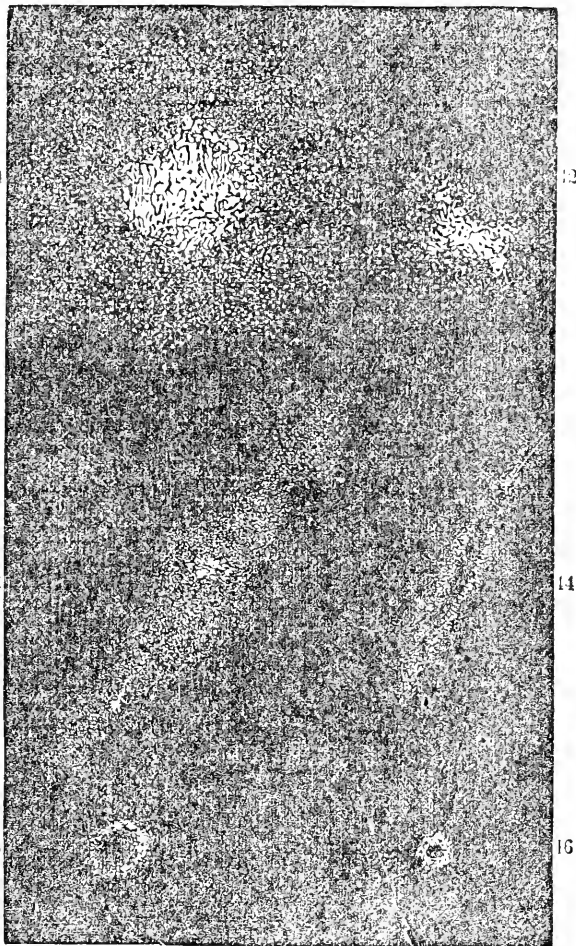

in the course of ages, be condensed into stars or starry systems. The following is a description of some of the more remarkable varieties of this class of nebulae.

Fig. 43 represents a nebula of an elliptical or spindle-like form. It is visible to the naked eye in a clear night, when the moon is absent, and has sometimes been mistaken for a small comet. It appears like a dull, cloudy, undefined spot upon the concave of the firmament, and has sometimes been compared to the light of a small candle shining through horn. Its central parts appear brightest, but its light gradually fades toward each extremity. A few small stars appear adjacent to it, and even within its boundaries, but it appears pretty evident that they have no *immediate* connection with the nebula. Its form, as here delineated, may be seen with a telescope of moderate power, but no telescope hitherto constructed, even with the highest powers that could be applied, has yet been sufficient to resolve it into stars. In size, it is nearly half a degree long, and 12 or 15 minutes broad. Though the figure of this object appears oval or elliptical, it is not unlikely that it is

in reality nearly of a globular figure, and that its oval appearance is owing to its position with regard to our eye. This nebula is situated in the girdle of Andromeda, within a degree or two of

the star  $\gamma$  of that constellation. It is about  $15^{\circ}$  nearly west from *Almaaz*  $\beta$ , and  $8^{\circ}$  north-by-west of *Merach*, with which star, it forms nearly a right-angled triangle. It may be seen in a north-

## PLATE V.

MINIATURE MAP OF THE HEAVENS, ON MERCATOR'S PROJECTION, SHOWING THE COURSE OF THE MILKY WAY.

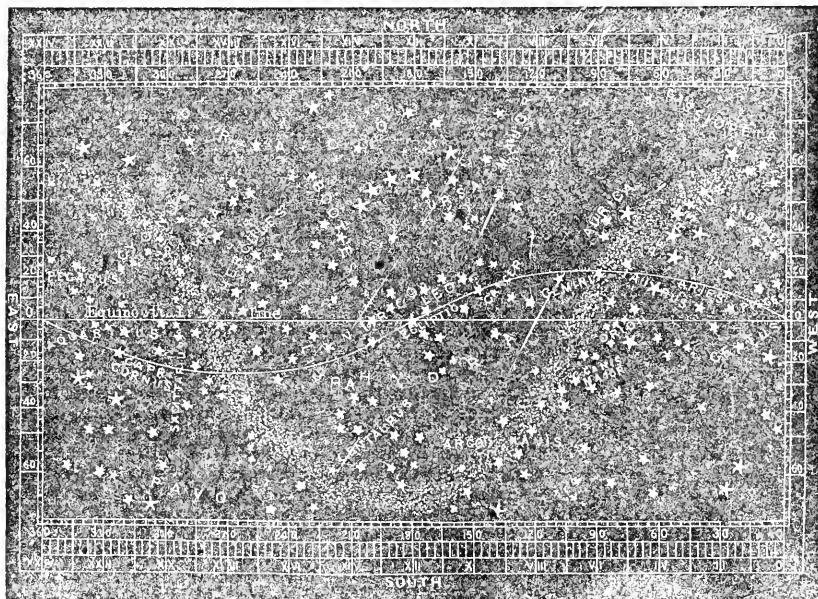

westerly direction in the evenings of the months of January, February, and March, at a considerable elevation. It comes to the meridian about the middle of November, at nine o'clock in the evening. Its right ascension is  $0^{\text{h}}. 33'$ ; and north declination,  $40^{\circ} 20'$ . This nebula may be considered as a representative, on a large scale, of a numerous class of nebulae, which increases more or less in density toward the central point. The representation of it in the plate is somewhat longer and narrower than it appears through a telescope magnifying 140 times.

Fig. 44 represents a kind of elliptical nebula, with a vacancy of a lenticular form in the center. It is pretty evident that such nebulae are in reality large rings, which appear of an oval or lenticular form in consequence of their lying obliquely to our line of vision. This is undoubtedly a large starry system, comprising perhaps millions of stars, at such a distance that their combined light appears only like a faint nebula. It probably is not much unlike the form of our Milky Way in which the sun is situated. Its right ascension is  $2^{\text{h}}. 12'$ , and north decl.  $41^{\circ} 35'$ . It lies near  $\gamma$  Andromeda, or *Almaach*, about  $1^{\circ}$  to the eastward of that star, nearly in a line between it and *Algol*, in the head of Medusa, and about  $19^{\circ}$  east from the nebula represented in Fig. 43.

Fig. 45 is a representation of an *annular* nebula, which may be seen with a telescope of moderate power. It does not occupy so much space in the heavens as the preceding nebulae, but it is well defined, and has the appearance of a flat, solid ring. It is not perfectly circular, but somewhat elliptical, the conjugate axis of the ellipse being to the transverse nearly to the proportion of 4 to

5. The opening occupies about half its diameter, and is not entirely dark, but filled up with a very faint hazy light, uniformly spread over it. Its light is not of a pure milky white, but is somewhat mottled in its appearance near the exterior edge. This curious phenomenon, like the preceding, is doubtless an immense stellar system, situated at an immeasurable distance in the profundity of space. It is situated in the constellation of Lyra, exactly half way between the stars  $\beta$  and  $\gamma$ , so that its position may be found by common observers without any difficulty. Its right ascension is  $18^{\text{h}}. 47'$ ; and north declination  $32^{\circ} 49'$ . The following cut (fig. 46) represents some of the principal stars in the constellation of the Lyre. The largest star near the upper part is *Vega*, a bright star of the first magnitude; the next larger star, south-by-east of which is  $\epsilon$ ; and the other star of the same magnitude to the south-east is  $\gamma$ ; between which is the annular nebula, about  $71^{\circ}$  from Vega.

Fig. 46 represents an object somewhat similar to the above. It is situated between the constellations Anser and Cygnus, about  $91^{\circ}$  south from the star  $\gamma$  Cygni, and  $17^{\circ}$  east from the phenomenon described above. Its right ascension is  $20^{\text{h}}. 9'$ ; and north declination,  $30^{\circ} 3'$ . It comes to the meridian, about the 10th of September, at nine o'clock in the evening.

The opposite page contains representations of several other kinds of nebulae, some of which are extremely curious and singular. Fig. 47 is a very singular and wonderful object. It has the shape of a dumb-bell or hour-glass of bright matter, surrounded by a thin hazy atmosphere; the two connected hemispheres, and the space which con-



nects them, are beautiful and pretty bright. The oval is completed by a space on each side, which is much more dim and hazy than the two hemispheres. The whole has an oval form, like that of an oblate spheroid. The southern hemisphere is somewhat denser than the northern, and there are one or two stars in it. It appears evidently to be a dense collection of stars, at an immeasurable distance from the region in which we reside, and leads us to form an idea of the endless diversities of shape and form among those countless assemblages of stars with which the universe is replenished. This nebula is situated in right ascension, 19h. 52'; north declination, 22° 16'; in the breast of Anser et Vulpecula, about midway between Alureo in the Swan, and the principal stars of the Dolphin, about three or four degrees north of Sagitta, a star of the fourth magnitude.

Fig. 48 is likewise a very remarkable object. It consists of a bright round nucleus, or central

part, surrounded at a great distance by a nebulous ring. This ring appears split through nearly the greater part of its circumference, the two portions of which being separated at about an angle of 45°. This nebula lies near the remotest boundaries to which our telescopes can carry us. It has never been resolved into stars by the highest powers that have yet been applied; but there is little doubt that it is a grand scheme of 47 sidereal systems, perhaps exceeding our Milky Way in number and magnificence. It is indeed supposed to bear a more striking resemblance to the system of stars in which the sun is placed than any other object which has yet been discovered in the heavens, as may be perceived by turning to figure 39, (p. 62), which represents Sir W. Herschel's scheme of the Milky Way; and hence Sir J. John Herschel describes it as "a brother system, bearing a real physical resemblance and strong analogy of structure to our own." This object, dim and distant as it may appear through our telescopes, and utterly invisible as it is to the unassisted eye, may be considered as a kind of universe in itself, ten thousand times more grand and extensive than the whole creation was supposed to be in the infancy of astronomy. Like the preceding nebula, it shows us what singular varieties of structure are to be found in the systems which compose the universe, and at the same time it exhibits a certain resemblance to another system of which we form a part; and perhaps something similar, though not precisely of the same form and arrangement, may be found in other parts of the sidereal heavens. This phenomenon is situated near the back of Asterion, about five degrees south-by-west of *Benetnasch*, the last star in the tail of the Great Bear; between which star and the nebula there is a small star of the fifth magnitude, nearer to the nebula than to *Benetnasch*. Its right ascension is 13h. 22'; and north declination, 46° 14'.

Fig. 46.\*

North.

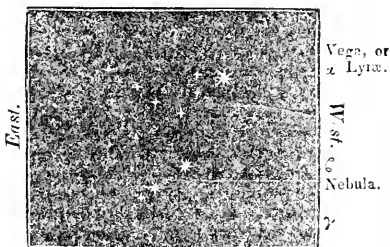

Figures 49, 50, 52, 53, 54, 55, 56, 57, and 58, represent some specimens of *nebulous stars*, or of *nebulae* connected with very small stars.

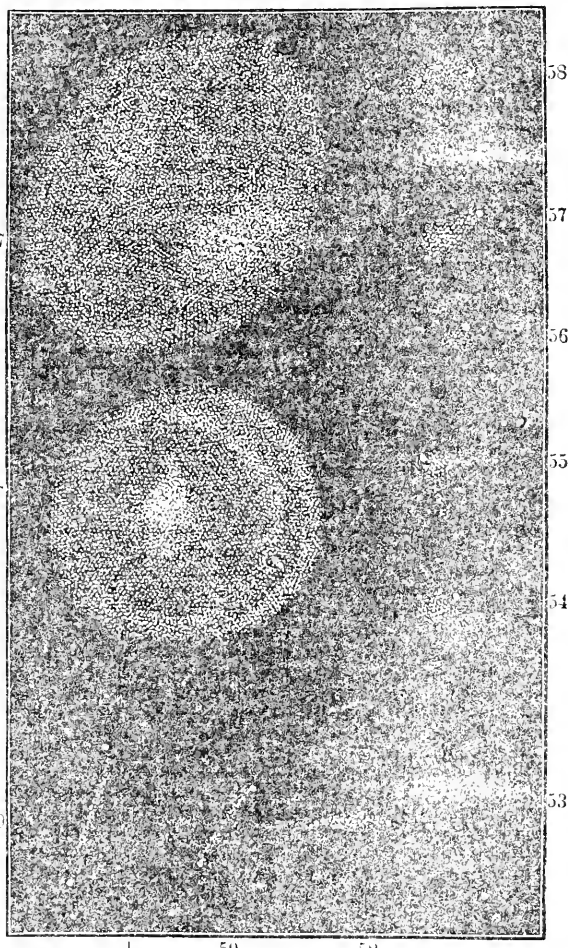

Figure 49 shows a *nebulousity*, or something like a *nebulous stream*, extending from one small star

\* It may not be improper here to remark, once for all, that the bearings or directions of the stars from one another, given here and in other parts of this volume, are strictly applicable only when the principal star, from which the bearings are stated, is on or near the *meridian*. When in other positions, they will appear to a common observer to have

to another, as if there was a communication between them. The next three figures are representations of similar phenomena. In figure 52 the nebulous substance appears much broader

which appear in its vicinity, it is difficult to conjecture. It is a species of nebula which does not appear to be resolvable into stars, and therefore may be regarded as a distinct luminous

substance diffused throughout different regions of the universe, subserving some important designs in the physical economy of creation of which we are ignorant. Specimens of some of these phenomena will be found in the following situations:—1. Right ascension, 20h. 56'; north declination,  $11^{\circ} 24'$ ; a little to the east of the cluster of stars called the Dolphin. 2. Right ascension, 8h. 46'; north declination,  $54^{\circ} 25'$ ; about seven degrees north-west of the star *Thota* of the Great Bear. 3. Right ascension, 12h. 51'; north declination,  $35^{\circ} 47'$ ; about four degrees south of the star *Cor Caroli*, the principal star in the Greyhounds. 4. Right ascension, 6h. 30'; north declination,  $8^{\circ} 53'$ ; which is in the head of Monoceros, or the Unicorn, about eleven degrees east of Betelgeuse, in the right shoulder of Orion, and about seven degrees due south of Gemini, which is in the left foot of one of the twins.

Figures 59 to 63 represent a few specimens of objects which come under the denomination of *extensive diffusive nebulosities*. These phenomena were very little noticed until lately, and can only be perceived by telescopes of large aperture, which collect a great quantity of light. In alluding to one of these objects, Sir W. Herschel describes it as follows:—"Extreme faint branching nebosity; its whiteness is entirely of the milky kind, and it is brighter in three or four places than the rest; the stars of the Milky Way are scattered over it in the same manner as over the rest of the heavens. Its extent in the parallel is nearly one degree and a half, and in

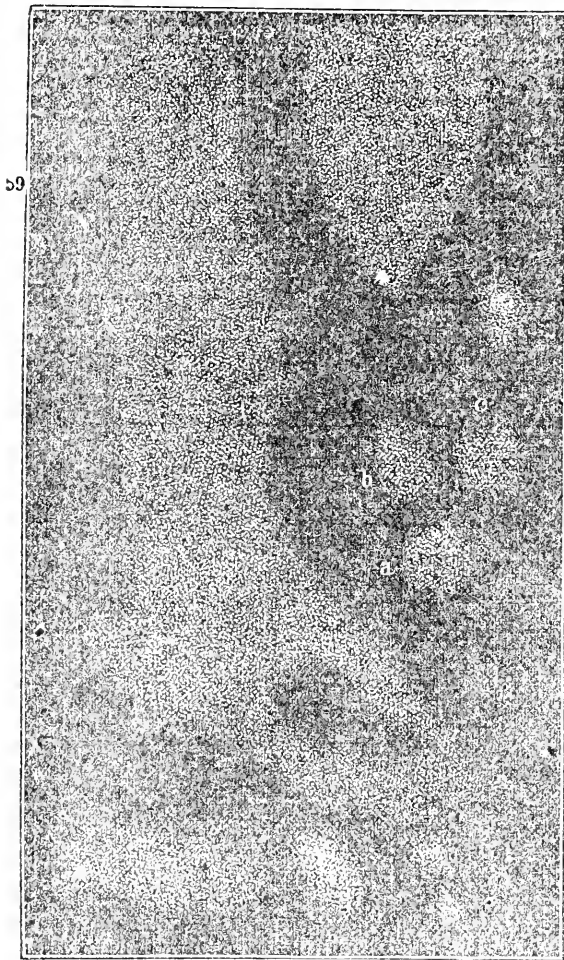

than in the others, though this may possibly be owing to the nebula in its greatest extent being presented to our line of vision.

Figures 54, 55, 56, are very small stars, with faint and small nebulae attached to them in the shape of a puff. Fig. 57 is a small star, with a small, faint, fan-shaped nebosity joined to it. Fig. 58 represents two considerable stars involved in a very faint nebosity of three or four minutes in extent. What this nebulous substance in reality is, or what connection it may have with the stars

different bearings; for example, the star *Thota* or *Lynx*, in the above figure, when about 50 or 60° above the western horizon, will appear at an equal altitude as the star *Beta*, south-west-by-south of it; and when about 70 or 80° above the eastern horizon, the two stars will appear, the one directly above or below the other. This difference in the apparent directions of the stars from each other is most observable in those which are near the pole; for example, the stars of the Great Bear appear in one part of their revolution west from the pole, and in another part of their course east of it. These and other circumstances require to be attended to, in order to find particular stars by their bearings from one or more principal stars.

the meridional direction about fifty-two minutes." It appears that this diffused nebosity is very extensive; for of fifty-two nebulae of this description which had never been before observed, Herschel found them to occupy no less than 152 square degrees. A specimen of an extensive diffusive nebula of this description is represented in fig. 59.

Sir W. Herschel has presented us with fourteen specimens related to this class, of what he terms *nebulosities joined to nebulae*, one of which is represented in fig. 60, where a bright nebulous speck is connected with a faint nebosity, which seems to proceed from it as from a central point, increasing in breadth in proportion to the distance, until it terminates in a kind of irregular margin. Fig. 61 represents what is called a *milky nebula with condensation*. It appears to be a roundish nebula, condensed toward the central parts. It is natural to suppose, when we see a gradual increase of light, that there is a condensation of the substance which produces it in the space which appears brightest, or at least that the



luminous substance is *deeper* in the brighter space. Some of the nebulosities of this class are not always extensively diffused, but are sometimes met with in detached collections, near to each other, but completely separate, as represented at *a, b, c*, fig. 62.

A diffused nebulosity of this kind may be seen about six or seven degrees due east from the star *Zeta Cygni*, near the back or tail of Anser. Its right ascension is  $20^{\text{h}} 3'$ , and north declination  $30^{\circ} 6'$ . Another, whose right ascension is  $20^{\text{h}} 43'$ , and north declination  $31^{\circ} 3'$ , is found about three or four degrees north-west 66 of *Zeta Cygni*, and within two or three degrees of the preceding.

Figures 62, 64, and 65, are representations of nebulae which are brighter in more than one place, which appearance is supposed to be owing to so many predominant seats of attraction, owing to a superior preponderance of the nebulous matter in those places, causing a division of it, from which will arise three or four distinct nebulae.

Figures 66 to 71 are representations of nebulae of various descriptions. The three upper figures, numbered 66, are nebulae that are *suddenly much brighter in the middle*. A nucleus to which these nebulae seem to approach is considered as indicating consolidation; and that, should we have reason to conclude that a solid body can be formed of condensed nebulous matter, the nature of which has been chiefly deduced from its shining quality, we may possibly be able to view it with respect to some other of its properties. The three figures, No. 67, represent *extended nebulae and round nebulae, that show the progress of condensation*. These nebulae appear further condensed than the preceding, and appear surrounded with the rarest nebulous matter, which, not having as yet been consolidated with the rest, remains expanded about the nucleus in the shape of a very extended atmosphere. The three figures in the third row from the top of the plate, marked No. 68, and the first figure to the left hand of No. 69, represent nebulae which are almost of a uniform light, and nebulae that draw progressively toward a period of final condensation. "In the course of the gradual condensation of the nebulous matter," says Sir W. Herschel, "it may be expected that a time must come when it can no longer be compressed, and the only cause which we may suppose to put an end to the compression is, when the consolidated mass assumes hardness. From the size of the nebulae, as we see them at present, we cannot form an idea of the original bulk of the nebulous matter they contain; but let us admit, for the sake of computation, that the nebulosity of a certain nebula, when it was in a state of diffusion, took up a space of ten minutes in every caldical direction of its expansion, then, as we now see it collected into a globular compass of less than one minute, it must of course be more than 1300 times denser than it was in its original

state. This proportion of density is more than double that of water to air."

The small nebulae represented in No. 70 are *stellar nebulae*, which approach to the appearance of stars, and one or two of doubtful character. The four figures marked No. 71, represent separate views of the gradual condensation of the nebulous substance. In these we may evidently perceive a striking gradation in the light and bril-



liancy of the central parts. The figure on the left-hand side represents an object nearly in its original state of nebulosity; the next toward the right appears considerably condensed toward the central parts; the third figure represents a condensation still greater; and the one on the right-hand exhibits a condensation nearly complete, or a huge luminous body surrounded with a lucid atmosphere. Each of these is the representative of an extensive class of objects of this description.

### SECTION III.

#### ON PLANETARY NEBULAE.

This designation is given to a class of nebulae which bear a very near resemblance to planetary discs when seen through telescopes. But, notwithstanding their planetary aspect, some small

remaining haziness, by which they are more or less surrounded, evinces their nebulous origin. They are somewhat extraordinary objects, with round or slightly oval discs, in some instances quite sharply terminated, in others, a little hazy at the borders, and of a light exactly equable, or only a very little mottled, which in some of them approaches in vividness to the light of actual planets. The following are some of Sir W. Herschel's remarks on these bodies:—If we should suppose them to be single stars with large diameters, we shall find it difficult to account for their not being brighter, unless we should admit that the intrinsic light of some stars may be very much inferior to that of the generality, which, however, can hardly be imagined to extend to such a degree. We might suppose them to be comets about their aphelion, if the brightness as well as the magnitude of their diameters did not oppose this idea; so that, after all, we can hardly find any hypothesis so probable as that of their being nebulae; but then they must consist of stars that are compressed and accumulated in the highest degree. At a subsequent period Sir William remarks, "When we reflect on the circumstances connected with these bodies, we may conceive that, perhaps, in progress of time these nebulae which are already in a state of compression may be still farther compressed so as actually to become stars. It may be supposed that solid bodies such as we suppose the stars to be, from the analogy of their light with that of our sun when seen at the distance of the stars, can hardly be formed of a condensation of nebulous matter; but if the immensity of it required to fill a cubical space which will measure ten minutes, when seen at the distance of a star of the eighth or ninth magnitude, is well considered, and properly compared with the very small angle our sun would subtend at the same distance, no degree of rarity of the nebulous matter to which we have recourse can be any objection to the solidity required for the construction of a body of equal magnitude with our sun."

The nature of these nebulae is involved in considerable darkness and mystery. As in the case of some of the other species of these phenomena, so in this, the mind feels unable to form any definite or satisfactory conceptions on the subject. The following remarks of Sir J. Herschel comprise most of what can be stated, in the meantime, on this subject:—"Whatever be their nature, they must be of enormous magnitude. One of them is to be found in the parallel of  $\gamma$  Aquarii, and about five minutes preceding that star. Its apparent diameter is about twenty seconds. Another, in the constellation Andromeda, presents a visible disc of twelve seconds perfectly defined and round. Granting these objects to be equally distant from us with the stars, their real dimensions must be such as would fill, on the lowest computation, the whole orbit of Uranus. It is no less evident that, if they be solid bodies of a solar nature, the intrinsic splendor of their surfaces must be almost infinitely inferior to that of the sun's. A circular portion of the sun's disc, subtending an angle of twenty seconds, would give a light equal to 100 full moons, while the objects in question are hardly, if at all, discernible with the naked eye. The uniformity of their discs, and their want of apparent central condensation, would certainly augur their light to be merely superficial, and in the nature of a hollow superficial shell; but whether filled with solid or gaseous matter, or altogether empty, it would be a waste of time to conjecture."

In this description there is nothing which strikes the mind with such astonishment as the enormous magnitude of these planetary nebulae. A globular body which would fill the orbit of Uranus would contain 24,429,081,600,000,000,000,000,000,000, or more than twenty-four thousand *quadrillions* of solid miles. The solid contents of the sun is about 357,000,000,000,000,000, or three hundred and fifty-seven thousand *billions* of cubical miles. If the former number be divided by the latter, the quotient will be 68,428,800,000, showing that the nebula in question would contain within its circumference sixty-eight thousand, four hundred and twenty eight millions, and eight hundred thousand globes as large as the sun. A body of such bulk is more than thirty-four billions, two hundred thousand millions of times larger than all the primary planets and their satellites which belong to our system. What is the special destination of such huge masses of matter, or what important designs they subservise in the physical and moral arrangements of the Governor of the universe, it is beyond our power, in the meantime, to form even a probable conjecture. Future generations may perhaps be enabled to throw some light on this subject, though it is probable that the nature, properties, and ultimate designs of many such objects will only be fully disclosed throughout the revolutions of that interminable duration which succeeds the short span of human existence; but of this we may rest assured, that they are *not useless* masses of materials in the universe, but are subservient to purposes worthy of Him whose wisdom is infinite, and whose understanding is unsearchable.

The four figures toward the right-hand of the plate, marked No. 69, represent some specimens of planetary nebulae. One of those bodies may be seen near the star  $\nu$  Aquarii, as above stated. Its right ascension is nearly 20h. 52', and its south declination about 12° 36'. It lies north by west of the star *D. neb Algedi*, at the distance of about ten degrees. Other nebulae of this description may be found near the following stars:—3 *p* Sagittae, 14 Andromeda, 63 *b* Crateris, 61 *g* Sagittae, 10 Camelopardus, 36 Ursae Majoris, 6 Navis, and 6 Draconis. About three minutes west from the star 16 *c* Cygni the following phenomenon is found:—A bright point a little extended, like two points close to each other. It is as bright as a star of the eighth or ninth magnitude, surrounded by a very bright milky nebulosity, suddenly terminated, having the appearance of a planetary nebula with a lucid center. The border is not well-defined; it is perfectly round, and about one minute and thirty seconds in diameter. This is a beautiful phenomenon, and of a middle species between the planetary nebulae and nebulous stars.

Sir John Herschel, during his late residence at the Cape of Good Hope, is said to have discovered several new and singular objects in the southern hemisphere, some of them bearing a certain relation to the objects now described; among others, he is said to have detected a beautiful planetary nebula, which presents a perfectly sharp, well-defined disc of uniform brightness, exhibiting the exact appearance of a small planet with a satellite near its margin. The regular compactness and globular form of such objects seem to indicate that they are bodies *sui generis*, neither collections of distinct stars nor exactly of the same nature with the other masses of nebulous matter dispersed through the heavens. They seem to present a view of an immense system already completed, but of what nature it would be vain to conjecture. Another phenomenon of this kind

is stated as being of an extraordinary nature, on account of the *blue* color which its light exhibits. He has likewise discovered a close double star involved in the center of a nebulous atmosphere, which is considered as a new and singular object.

## SECTION IV.

## ON THE NEBULA IN ORION.

ONE of the largest and most remarkable nebula in the heavens is that which is found in the constellation of Orion. When a common observer looks at that constellation, the first object that arrests his attention is the three brilliant stars equidistant from each other in a straight line, which is called the *belt* of Orion. Immediately below these, hanging down as it were from the middle of the belt, three small stars at nearly equal distances are perceived, which are termed *the sword*. On directing the naked eye to the middle star of the three, the observer perceives something that has the appearance of a small star, but not well-defined; this is the great nebula of Orion; of which, however, he can form no definite conception until his eye be assisted by optical instruments. With a common one-foot pocket achromatic telescope the nebosity may be plainly perceived; but the higher the magnifying power, and the larger the aperture of the object-glass, the more brilliant and distinct does this phenomenon appear, along with a number of small stars connected with it, which are quite invisible to the unassisted eye.

The first who discovered this phenomenon was the celebrated Huygens, who gave the following description of it in his *Systema Saturnium*:—"Astronomers place three stars close to each other in the sword of Orion; and when I viewed the middlemost with a telescope in the year 1656, there appeared, in the place of that one, twelve other stars; among these, three that almost touch each other, and four more beside appeared twinkling as through a cloud, so that the space about them seemed much brighter than the rest of the heavens, which appearing wholly blackish, by reason of the fair weather, was seen as through a certain opening, through which one had a free view into another region which was more enlightened. I have frequently observed the same appearance in the same place, without any alteration; so that it is likely that this wonder, whatever it may be in itself, has been there from all times; but I never took notice of anything like it among the rest of the fixed stars."

Fig. 72 exhibits a view of this phenomenon as seen by Dr. Long in 1741 with a seventeen-foot refracting telescope, which appears exactly the same shape as originally delineated by Huygens; but the apparent magnitudes of the stars connected with it are more accurately shown than in the engraved delineation of Huygens. Dr. Long says that the luminous space has sometimes appeared to him nearly of the same shape as the figure which is formed by the seven stars within it. Fig. 73 repre-

sents the same nebula, as seen by Sir W. Herschel in the year 1774 and in 1811. Its shape appears considerably different from the delineations of Huygens and Dr. Long; but the stars within and around it, which are common to both delineations, appear nearly in the same relative position. Sir John Herschel has given a representation of this nebula, as viewed through the twenty-foot reflector at Slough, which appears considerably different from the figures to which I have referred. I have frequently viewed this phenomenon with telescopes of different sizes, particularly with a six feet and a half achromatic, having an aperture of four inches diameter, and which showed sideral objects with great brilliancy and distinctness; but the shape of the object appeared more nearly resembling Dr. Long's representation (fig. 72) than any other delineation I have seen. A fourth star was distinctly seen in addition to the three represented by Dr. Long near the head of the opening, but smaller than the other three, and forming with them a small irregular square. The three other stars, instead of being *within* the one side of the nebula, as represented in both the figures, appeared quite beyond it, but nearly in a line with its margin. Whether this was owing to the inaccuracy of the delineation or to the actual change of the nebula I do not pretend to determine. The left-hand branch of the nebula likewise appeared considerably longer than here represented; but I cannot pretend to say what the appearance may be as seen through a twenty-foot reflecting telescope.

In forming a proper conception of this object, it is of some importance to ascertain the exact appearance it has presented at different periods,

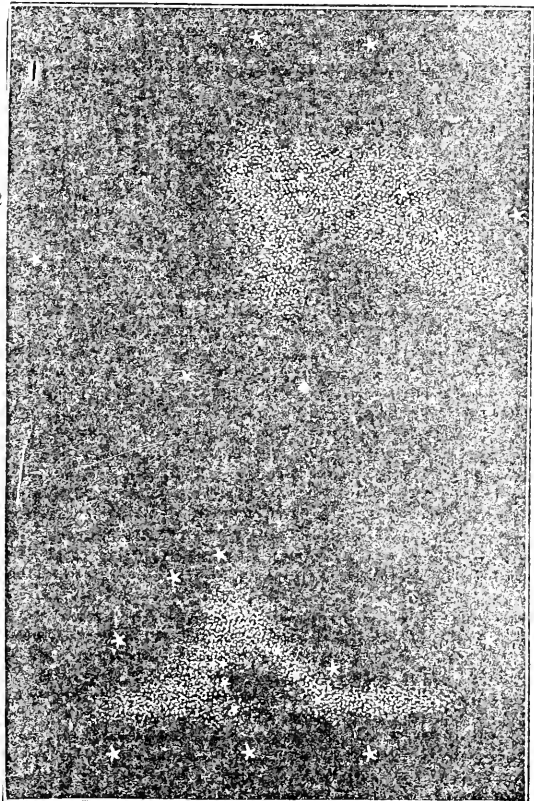

and whether there be reason to conclude that it has been subject to changes. The following is Sir J. Herschel's description of this phenomenon:

"I know not how to describe it better than by comparing it with a curdling liquid, or a surface strewed over with flocks of wool, or to the breaking up of a mackerel sky, when the clouds of which it consists begin to assume a cirrous appearance. It is not very unlike the mottling of the sun's disc, only, if I may so express myself, the grain is much coarser and the intervals darker, and the flocculi, instead of being generally round, are drawn into little wisps. They present, however, an appearance of being composed of stars, and their aspect is altogether different from that of resolvable nebulae. In the latter we fancy by glimpses that we see stars, or that could we strain our sight a little more we would see them; but the former suggests no idea of stars, but rather of something quite distinct from them."

The following are some of Sir W. Herschel's remarks on this nebula, and on stars with which it is connected:

"In the year 1774, the 1th of March, I observed the nebulous star which is the 43d of the *Connoissance des Temps*, and is not many minutes north of the great nebula; but at the same time I also took notice of two similar, but much smaller, nebulous stars, one on each side of the large one and at nearly equal distances from it.—(See fig. 73, &c.) In 1783, I examined the nebulous star, and found it to be faintly surrounded with a circular glory of whitish nebulosity, faintly joining it to the great nebula. About the latter end of that year I remarked that it was not equally surrounded, but most nebulous toward the south. In 1784, I began to entertain an opinion that the star was not connected with the nebulosity of the great nebulae of Orion, but was one of those which are scattered over that part of the heavens. In 1801, 1806, and 1810, this opinion was fully confirmed by the gradual change which happened in that great nebula to which the nebulosity surrounding the star belongs; for the intensity of light about the nebulous star had by this time been considerably reduced by the attenuation of dissipation of the nebulous matter, and it seemed now to be pretty evident that the star is far behind the nebulous matter, and that consequently its light in passing through it is scattered and deflected so as to produce the appearance of a nebulous star." . . . "When I viewed this interesting object in December, 1810, I directed my attention particularly to the two nebulous stars by the sides of the large one, and found they were perfectly free from every nebulous appearance, which confirmed not only my former surmise of the great attenuation of the nebulosity, but also proved that their former nebulous appearance had been entirely the effect of the passage of their feeble light through the nebulous matter spread out before them.—The 19th of January, 1811, I had another critical examination of the same object, in a very clear view, through the forty-foot telescope; but notwithstanding the superior light of this instrument, I could not perceive any remains of nebulosity about the two small stars, which were perfectly clear, and in the same situation where about thirty-seven years before I had seen them involved in nebulosity. If, then, the light of these three stars is thus proved to have undergone a visible modification in its passage through the nebulous matter, it follows that its situation among the stars is less distant from us than the largest of the three, which I suppose to be of the eighth or ninth magnitude. The farthest distance, therefore, at

which we can place the faintest part of the great nebula in Orion, to which the nebulosity surrounding the star belongs, cannot well exceed the region of the stars of the seventh or eighth magnitude."

From these observations it would appear that the nebulosities connected with the great nebula are subject to certain changes, and that its distance from our system is less than that of stars of the eighth magnitude, since a portion of the nebulous matter interposes between our sight and stars of this description. But this distance must be very great. If stars of the eighth magnitude are to be considered at an average as eight times farther distant than those of the first, then this nebula cannot be supposed to be less than 320,000,000,000,000, or three hundred and twenty billions of miles from the earth. If its diameter at this distance subtend an angle of ten minutes, which it nearly does, its *magnitude* must be utterly inconceivable. It has been calculated that it must exceed 2,000,000,000,000,000,000, or two trillions of times the dimensions of the *sun*, vast and incomprehensible as these dimensions are.

This nebula has never yet been resolved into stars by the highest powers of the telescope that have yet been applied; nor is there any reason to believe that it consists of a system of stars, as is the case with many other nebulae which appear much smaller, and are evidently more distant. It is therefore, in all probability, a mass of self-luminous matter not yet formed into any system or system, but of what nature it would be vain to conjecture. Whether it is more condensed than when it was first observed nearly two hundred years ago, as some have conjectured, or whether any portions of it have shifted their position, as seems to have been the opinion of Sir W. Herschel from the observations above stated, appears on the whole somewhat uncertain. On this point Sir J. Herschel makes the following remark:—"Several astronomers, on comparing this nebula with the figures of it handed down to us by its discoverer, Huygens, have concluded that its form has undergone a perceptible change; but when it is considered how difficult it is to represent such an object, duly, and how entirely its appearance will differ even in the same telescope, according to the clearness of the air, or other temporary causes, we shall readily admit that we have no evidence of change that can be relied on."

The phenomenon we have now been contemplating is calculated to suggest a train of reflections and inquiries.—What is the grand design in the system of nature of such an immense mass of luminosity—a mass of luminous matter to which the whole solar system is but only as a point—a mass at least twenty-nine millions of times larger than a globe which *would fill the orbit of Uranus*?\* Is it in a state of perfection completely answering the ultimate end of its creation, and will it remain forever in that state? Or, is it only a chaotic mass of materials progressing toward some glorious consummation in the future ages of eternity, when worlds and systems will be evolved from the changes and revolutions now going forward within its boundaries? Or, may we suppose that a luminosity of so vast extent serves the purpose of a thousand suns to ten thousands of opaque globes which revolve within its wide circumference? Considering the diversified methods of Divine operation, and the vast variety of modes by which worlds are arranged and enlightened, it is not impossible, nor even

\*See page 74

improbable, that numerous worlds may be in this way illuminated with a perpetual and uninterrupted day. As there appear to be worlds connected with one sun, with two, with three, and even more suns, so there may be thousands of worlds cheered and illuminated without such a sun as ours, and with an effulgence of light which is common to them all. But on these points we shall never be able to arrive at certainty so long as we sojourn in this sublunary sphere. Suffice it to say, that such an enormous mass of luminous matter was not created in vain, but serves a purpose in the divine arrangements corresponding to its magnitude and the nature of its luminosity, and to the wisdom and intelligence of Him whose power brought it into existence. It doubtless subserves some important purposes, even at the present moment, to worlds and beings within the range of its influence. Were we placed as near it as one-half the distance of the nearest star, great as that distance is, from such a point it would exhibit an effulgence approximating to that of the sun; and to beings at much nearer distances it would fill a large portion of the sky, and appear with a splendor inexpressible.—But the ultimate design of such an object, in all its bearings and relations, may perhaps remain to be evolved during the future ages of an interminable existence; and, like many other objects in the distant spaces of creation, it excites in the mind a longing desire to behold the splendid and mysterious scenes of the universe a little more unfolded.

## SECTION V.

### ON THE NEBULAR HYPOTHESIS.

I HAVE already stated that the nebulae may be arranged into two classes, the *resolvable* and *irresolvable*. When Sir W. Herschel commenced his observations on the nebulous part of the heavens, and for several years afterward, he was disposed to consider the nebulae in general to be no other than clusters of stars disguised by their very great distance; but a long experience and better acquaintance with the nature of nebulae convinced him that such a principle ought not to be universally admitted, although a cluster of stars may undoubtedly assume a nebulous appearance when it is too remote for us to discern the stars of which it is composed. When he perceived that additional light had no effect in resolving certain nebulae into stars, he was forced to the conclusion, that though milky nebulae may contain stars, yet there are also nebulosities which are not composed of them, nor immediately connected with them.

Hence astronomers have been constrained to admit the existence of a certain species of fine luminous matter, distinct from stars, or planets, or any other materials existing around us, which is diffused in immense masses throughout the spaces of the universe. The large nebula in Orion, described above, is considered as one of the most striking evidences that such a substance is distributed throughout the sidereal regions; for the whole light and power of Herschel's forty-foot telescope, though four feet in aperture, was insufficient to resolve it into stars, although from certain circumstances it appears to be one of the nearest, as it is one of the brightest, of those nebulous masses. It has therefore become a subject of interesting inquiry, 'What are those huge

masses of unformed matter we call the nebulae? and what purposes do they serve in the economy of creation?'

It is an opinion now very generally entertained, that the self-luminous matter to which we refer is the chaotic materials out of which new suns or worlds may be formed, and that it is gradually concentrating itself by the effect of its own gravity, and of the circular motions of which it may be susceptible, into denser masses, so as ultimately to effect the arrangement and establishment of sidereal systems. It is argued that this opinion is highly probable, from the consideration that we find the nebulae in almost every stage of condensation. Such nebulae as are represented in Figures 59 and 62 are viewed as consisting of nebulous matter in its rudest and most chaotic state; and Figures 63, 64, 65, and also Figures 66, 67, 68, as similar matter in a state of progress toward condensation. The four figures marked 71 are considered as specimens of this gradual condensation, in which the progress may be traced from the left-hand figure to the right. It has even been maintained by some late writers on this subject that this, in all probability, is the mode in which the different systems of the universe were gradually brought into the state in which we now behold them, and that the sun and planets of the system to which we belong derived their origin from a similar cause; and it has likewise been attempted to connect the geological changes in the structure of our globe with the operation of a principle or law by which such a thin filmy substance as a nebula was condensed into such a heterogeneous mass of solidity as we find in the constitution of the terraqueous globe; and it has been insinuated that the zodiacal light is a portion of the original nebula of which the sun and planets were formed, and a presumptive evidence that the nebular hypothesis is true. According to these theorists, the sun is still to be considered as a nebulous star in a high state of condensation, and may exhibit such an appearance when viewed from a neighboring system.

Such conclusions, to say the least, are obviously premature. We know too little, in the meantime, of the nature of that nebulous matter which is dispersed through the heavens, or of the motions with which its particles may be indued, to be able to determine its susceptibility of being condensed and arranged into suns and planets. We have never yet seen the same nebula progressing from one stage of condensation to another, from a chaotic to a state of organization; nor is it likely we ever shall, even supposing the hypothesis to be well founded, as an indefinite number of years, or even of ages, must be requisite before such a revolution can be accomplished. Yet the observations of future astronomers on this department of the sidereal heavens may tend to throw some additional light on this mysterious subject.

It forms no conclusive argument, however, against this hypothesis that it is difficult to conceive how a fluid of a nature so apparently rare can ever be condensed to the hardness of a planet or a sun; for if we suppose a nebulosity in its most diffused state to be twenty minutes in diameter, and to be compressed by central attraction and rotary motion until it become only one minute in diameter, the ratio of its density in the latter state, compared with that of the former, would be as eight thousand to one, since spheres are to each other as the cubes of their diameters. Suppose its density in the first state were equal to that of atmospheric air; its density, when compressed in the proportion supposed, would be nine

times heavier than water, which is nearly equal to the weight of silver, and twice the average density of our globe; but if such a process be going on in any of these bodies, numerous ages must elapse before such a consolidation can be effected, for no sensible change appears to have taken place during the period in which such bodies have come under our observation.

Nor do we conceive that this hypothesis is inconsistent with what we know of the attributes and operations of the Almighty; for all the movements and changes going on in our terrestrial system and throughout the universe are the effects of certain laws impressed upon matter by the hand of the Creator, by the uniform operation of which his wise and beneficent designs are accomplished. If, then, it forms a part of his designs that new suns and systems shall be formed to diversify the spaces of immensity, and if he has created huge masses of subtle luminous matter, and induced them with certain gravitating powers and rotary motions for this purpose, his almighty agency and infinite wisdom may be as clearly and magnificently displayed in this case as if a system of worlds, completely organized, were to start into existence in a moment. Perhaps the gradual evolution of his designs in such a case might afford matter of admiration and enjoyment to certain orders of superior beings who are privileged to take a near view of such stupendous operations. But supposing such physical processes going forward, we must necessarily admit that a *direct interference of the Deity is necessary before such worlds, after being organized, can be replenished with inhabitants*; for matter and motion, by whatever laws they may be directed, cannot be supposed to produce the organization of a plant or an animal, much less of a rational being, whose intellectual principle and faculties must be communicated by the immediate "inspiration of the Almighty." To suppose otherwise would be virtually to adopt a species of atheism.

All that we require on this point is some more direct and decisive proofs of the validity of the hypothesis we are now considering; and until such proofs be elicited we are not warranted to enter into particular speculations, and to speak with so much confidence on the subject as certain theorists have lately done. Sir John Herschel, who has paid more attention to this subject, and made more accurate observations on these nebulae than almost any other individual, is far from being confident, and speaks with becoming hesitation and modesty in relation to this hypothesis. "If it be true," says he, "that a phosphorescent or self-luminous matter exists, disseminated through extensive regions of space in the manner of a cloud or fog—now assuming capricious shapes like actual clouds drifted by the wind, and now contracting itself like a cometic atmosphere around particular stars—what, we naturally ask, is the nature and destination of this nebulous matter? Is it absorbed by the stars in whose neighborhood it is found to furnish, by its condensation, their supply of light and heat? or is it progressively concentrating itself by the effect of its own gravity into masses, and so laying the foundation of new sidereal systems or of insulated stars? *It is easier to propound such questions than to offer any probable reply to them.* Meanwhile, appeal to fact, by the method of constant and diligent observation, is open to us; and as the double stars have yielded to this style of questioning, and disclosed a series of relations of the most intelligible and interesting description, we may reasonably hope that the assiduous study of the

nebulae will ere long lead to some clearer understanding of their intimate nature."

On the whole, the nebulae, whether resolvable or irresolvable, open to view an inexhaustible field of contemplation and wonder. By far the greater part of the nebulae are undoubtedly clusters of stars, some of them perhaps containing as many millions as our Milky Way, and occupying a space in the tracts of immensity which imagination can never fathom; but a considerable proportion of these bodies evidently appear to be masses of self-luminous substances, without any indication of being formed into organized systems; and how enormous must be the extent of most of these masses, and how vast the regions of space which they fill! If every one of those bodies be only one-half the size of the great nebula in Orion, what a prodigious mass of matter must they contain, and what an immense space must hundreds and thousands of them occupy! To limited minds such as ours, such spaces appear as approximating to *infinity*, and all our previous ideas of the amplitude of planetary systems sink into something approaching to inanity. Whatever purposes these immense masses of matter may serve under the administration of Infinite Wisdom, certain it is *they exist not in vain*. They accomplish designs worthy of the plans of Divine Intelligence, and have doubtless a relation, in one respect or another, to the enjoyments of intelligent beings; but the full development of the plans and agencies of the Deity in this, and in many other parts of the economy of the universe, must be considered as reserved for another and a future scene of existence.

## SECTION VI.

### LIST OF SOME OF THE LARGER NEBULÆ.

For the sake of those who wish to inspect some of the nebulous bodies by means of telescopes, I have subjoined the following list from Messier's Catalogue, along with the more recent observations of Sir W. Herschel. The right ascensions and declinations are given in degrees and minutes, by which the places of these bodies may be very nearly found on a celestial globe. If it be judged expedient to reduce the degrees and minutes of right ascension to *time*, it may be done by the following rules:—Divide the number of degrees by 15, the quotient is hours; and the remainder reduced to minutes and divided by 15, gives the minutes, &c. of time; or, multiply the given number of degrees and minutes by 4, and divide the degrees in the product by 60, the quotient is hours, and the remainder minutes, &c. Thus,  $320^{\circ} 17'$  is equal to 21 hours, 21 minutes, and 3 seconds of time.

In the following list, R. A. means right ascension; dec., declination; S., south; N., north; diam., diameter of the object, which is expressed in minutes of a degree.

1. R. A.  $80^{\circ} 0' 33''$ ; dec. N.  $21^{\circ} 45' 27''$ ; above the Bull's southern horn west of the star  $\zeta$ : this consists of a whitish light, elongated like the flame of a taper: it exhibited a mottled nebulousity to Sir W. Herschel.
2. R. A.  $320^{\circ} 17'$ ; dec. S.  $1^{\circ} 47'$ ; diam.  $4'$ ; in the head of Aquarius, near the 24th star: it appears like the nucleus of a comet, surrounded with a large round nebula: Sir W. Herschel resolved it into stars.

3. R.A. 202° 51' 19"; dec. N. 29° 32' 57"; diam. 3'; between Arcturus and Cor Caroli: it is round, bright in the center, and fades away gradually: it exhibited a mottled nebulosity to Sir W. Herschel.
4. R.A. 212° 16' 25"; dec. S. 25° 55' 40"; diam. 2½'; near *Antares*: a mass of stars.
5. R.A. 226° 39'; dec. N. 2° 57'; diam. 3'; near *6 Serpent*: a round nebula, resolved into stars by Sir W. Herschel.
6. R.A. 261° 10' 39"; dec. S. 32° 10' 34"; diam. 15'; between the bow of *Sagittarius* and the tail of *Scorpio*: a mass of small stars.
7. R.A. 264° 39' 24"; dec. S. 34° 40' 34"; diam. 30': a mass of small stars near the preceding.
8. R.A. 267° 23' 30"; dec. S. 24° 21'; diam. 30'; between the bow of *Sagittarius* and the right foot of *Ophiuchus*: an elongated mass of stars. Near this mass is the 9th of *Sagittarius*, which is encircled with a faint light.
9. R.A. 256° 20½'; dec. S. 18° 13' 26"; diam. 3'; in the right leg of *Ophiuchus*: round and faint, but resolved by Sir W. Herschel into stars.
10. R.A. 251° 12' 6"; dec. S. 30° 42'; diam. 4'; in the girdle near 30 *Ophiuchus*: a fine and round nebula, resolved into stars by Sir W. Herschel.
11. R.A. 279° 35' 43"; dec. S. 6° 31'; diam. 4'; near *K Antinous*: a mass of many stars, mixed with a faint light.
12. R.A. 218° 43'; dec. S. 2° 30½'; diam. 3'; between the arm and left side of *Ophiuchus*: round and faint: near it is a star of the ninth magnitude: resolved into stars by Sir W. Herschel.
13. R.A. 241° 18' 45"; dec. N. 36° 54' 44"; diam. 6'; in the girdle of *Hercules*, between two stars of the eighth magnitude: round, and bright in the middle, resolved into stars by Sir W. Herschel.
14. R.A. 261° 18½'; dec. S. 3° 5' 45"; diam. 7'; in the drapery over the right arm of *Ophiuchus*: round and faint: near a star of the ninth magnitude: resolved into stars by Sir W. Herschel.
15. R.A. 319° 40'; dec. N. 10° 49'; diam. 3'; between the head of *Pegasus* and that of the *Little Horse*: round, and bright in the center, resolved into stars by Sir W. Herschel.
16. R.A. 271° 15'; dec. N. 13° 51' 44"; diam. 8'; near the *Serpent's tail*: a mass of small stars, mixed with a faint light, resolved by Sir W. Herschel.
17. R.A. 271° 45' 48"; dec. S. 16° 14' 44"; diam. 5'; north of the bow of *Sagittarius*: a train of faint light, with stars.
18. R.A. 271° 34'; dec. S. 17° 13'; diam. 5'; above the preceding: a mass of small stars, surrounded with nebulosity.
19. R.A. 252° 1' 45"; dec. S. 25° 54' 46"; diam. 3'; between *Scorpio* and the right foot of *Ophiuchus*: round, and resolved into stars by Sir W. Herschel.
20. R.A. 267° 4' 5"; dec. S. 22° 59' 10"; between the bow of *Sagittarius* and the right foot of *Ophiuchus*: a mass of stars of the eighth and ninth magnitudes, surrounded with nebulosity.
21. R.A. 267° 31' 35"; dec. S. 22° 31' 25"; diam. 6'; near 11 *Sagittarius*: similar to the preceding.
22. R.A. 275° 28' 39"; dec. S. 24° 6' 11"; diam. 15'; near 25 *Sagittarius*: round, and resolved into stars by Sir W. Herschel.
23. R.A. 265° 42' 50"; dec. S. 18° 45', 55"; diam. 1° 30'; near 65 *Ophiuchus*: a mass of stars very near each other.
24. R.A. 270° 26'; dec. S. 18° 26'; near end of the bow of *Sagittarius* in the Milky Way: great nebulosity containing several stars, the light is divided into several parts.
25. R.A. 274° 25'; dec. S. 19° 5'; diam. 10'; near preceding, near 21 *Sagittarius*: a mass of small stars.
26. R.A. 278° 5' 22"; dec. S. 9° 38' 14"; diam. 2'; near *n* and *o Antinous*: a mass of small stars.
27. R.A. 297° 21' 41"; dec. N. 22° 4'; diam. 4'; near 14 of the *Fox*: oval: it exhibited a mottled nebulosity to Sir W. Herschel.
28. R.A. 272° 29½'; dec. S. 24° 57'; diam. 2'; a degree from  $\lambda$  *Sagittarius*: round, and resolved into stars by Sir W. Herschel.
29. R.A. 303° 54½'; dec. N. 37° 12'; below  $\gamma$  *Cygni*: a mass of seven or eight small stars.
30. R.A. 321° 46'; dec. S. 24° 19'; diam. 2'; near 41 *Capricorn*: round, and resolved into stars by Sir W. Herschel.
31. R.A. 7° 26½'; dec. N. 39° 9½'; diam. 40'; in *Andromeda's girdle*: it resembles two cones of light joined at their base, which is 15' broad: resolved into stars by Sir W. Herschel.
32. R.A. 7° 27½'; dec. N. 35° 45½'; diam. 2'; below the preceding: round, without stars, and with a faint light.
33. R.A. 29° 9'; dec. N. 29° 32½'; diam. 15'; below the head of the *North Fish* and the *Great Triangle*: its light is uniform and whitish: it exhibited a mottled nebulosity to Sir W. Herschel.
34. R.A. 36° 51½'; dec. N. 41° 39½'; diam. 15'; between *Medusa's head* and the left foot of *Andromeda*: a mass of small stars.
35. R.A. 88° 40'; dec. N. 24° 33½'; diam. 20'; near  $\mu$  and  $\nu$  *Castor*: a mass of small stars near *Castor's left foot*.
36. R.A. 80° 11' 42"; dec. N. 34° 8' 6"; diam. 9'; near  $\phi$  *Bootes*: a mass of small stars.
37. R.A. 84° 15'; dec. N. 32° 12'; near the preceding: a mass of small stars, with a nebulosity, resolved into stars by Sir W. Herschel.
38. R.A. 78° 10'; dec. N. 36° 12'; near  $\sigma$  *Aurigæ*: a square mass of stars.
39. R.A. 320° 57'; dec. N. 47° 25'; diam. 15'; near the *Swan's tail*: a mass of small stars.
40. R.A. 182° 45½'; dec. N. 59° 24'; diam. 1°; at the root of the *Great Bear's tail*: two stars, very near each other.
41. R.A. 98° 58'; dec. S. 20° 33'; below *Sirius*: a mass of small stars.
42. R.A. 80° 53' 40"; dec. S. 5° 34' 6"; diam. 6', between *b* and *c* in *Orion's sword*: a beautiful nebula containing seven small stars.
43. R.A. 81° 3'; dec. S. 5° 26' 37"; above the preceding: a star surrounded with nebulosity.
44. R.A. 126° 50½'; dec. S. 20° 31½'; between  $\gamma$  and  $\delta$  *Cancer*: a mass of small stars.
45. R.A. 53° 27' 4"; dec. N. 23° 22' 41"; the *Pleiades*: a cluster of stars.
46. R.A. 112° 47' 43"; dec. S. 14° 19'; between the *Great Dog's head*, and the hind feet of the *Unicorn*: a mass of stars with a little nebulosity.
47. R.A. 116° 4'; dec. S. 14° 50'; near the preceding: a mass of small stars.
48. R.A. 120° 36'; dec. S. 1° 16' 42"; near the three stars at the root of *Unicorn's tail*: a mass of small stars.
49. R.A. 184° 26' 58"; dec. N. 9° 16' 9"; near  $\rho$  *Virgo*.
50. R.A. 102° 57½'; dec. S. 7° 57' 42"; above  $\theta$



- Great Dog: a mass of small stars below Unicorn's right thigh.
51. R.A.  $200^{\circ} 5' 48''$ ; dec. N.  $48^{\circ} 24' 24''$ ; below  $\alpha$  Great Bear, near the ear of the Northern Greyhound: double: the two atmospheres, whose centers are  $4' 35''$  distant, touch one another, and are bright in the middle; the one is fainter than the other: resolved into stars by Sir W. Herschel.
  52. R.A.  $348^{\circ} 39\frac{1}{2}''$ ; dec. N.  $60' 22''$ ; below  $\delta$  Cassiopeia: a mass of stars mixed with a nebula; according to Sir W. Herschel: this cluster appears like a solid ball, consisting of small stars, quite compressed into one blaze of light, with a great number of loose ones surrounding it.
  53. R.A.  $195^{\circ} 30\frac{1}{2}''$ ; dec. N.  $19^{\circ} 22' 44''$ ; near  $\delta$  Berenice's hair: round, and resolved into stars by Sir W. Herschel.
  54. R.A.  $280^{\circ} 13'$ ; dec. S.  $30^{\circ} 44'$ ; diam.  $6'$ ; in Sagittarius: faint, and bright in the center.
  55. R.A.  $291^{\circ} 39\frac{1}{2}''$ ; dec. S.  $31^{\circ} 26\frac{1}{2}''$ ; in Sagittarius: a white spot, resolved into stars by Sir W. Herschel.
  56. R.A.  $287^{\circ}$ ; dec. N.  $29^{\circ} 48'$ ; near the Milky Way, faint, and resolved into stars by Sir W. Herschel.
  57. R.A.  $281^{\circ} 20'$ ; dec. N.  $32^{\circ} 46'$ ; between  $\gamma$  and  $\zeta$  Lyrae: round, and consisting of a mottled nebula.
  58. R.A.  $136^{\circ} 37\frac{1}{2}''$ ; dec. N.  $13^{\circ} 2' 42''$ ; in Virgo: very faint, without any star.
  59. R.A.  $187^{\circ} 41' 38''$ ; dec. N.  $12^{\circ} 52\frac{1}{2}''$ ; near the preceding: very faint, without any star.
  60. R.A.  $188^{\circ} 7'$ ; dec. N.  $12^{\circ} 46'$ ; in Virgo: brighter than the two preceding.
  61. R.A.  $182^{\circ} 41'$ ; dec. N.  $5^{\circ} 12'$ ; in Virgo: very faint.
  62. R.A.  $251^{\circ} 42\frac{1}{2}''$ ; dec. S.  $29^{\circ} 45\frac{1}{2}''$ ; in Scorpio: like a comet, with a brilliant center surrounded with a faint light; resolved into stars by Sir W. Herschel.
  63. R.A.  $196^{\circ} 51\frac{1}{2}''$ ; dec. N.  $43^{\circ} 12\frac{1}{2}''$ ; in the Canes Venatici: very faint.
  64. R.A.  $191^{\circ} 27' 38''$ ; dec. N.  $22^{\circ} 52\frac{1}{2}''$ ; in Berenice's hair: faint.
  65. R.A.  $166^{\circ} 51'$ ; dec. N.  $14^{\circ} 16'$ ; in the Lion: faint, but resolved into stars by Sir W. Herschel.
  66. R.A.  $167^{\circ} 11' 39''$ ; dec. N.  $14^{\circ} 12' 21''$ ; very near the preceding: very faint, but resolved into stars by Sir W. Herschel.
  67. R.A.  $129^{\circ} 7'$ ; dec. N.  $12^{\circ} 36' 38''$ ; below the northern claw of the Crab: a mass of stars with nebula. It is a cluster pretty much compressed, in which Sir W. Herschel has observed 200 stars at once with a power of 157. (See p. 63.)
  68. R.A.  $186^{\circ} 54\frac{1}{2}''$ ; dec. S.  $25^{\circ} 30\frac{1}{2}''$ ; diam.  $2'$ ; below the Crow, very faint.
  69. R.A.  $274^{\circ} 11' 46''$ ; dec. S.  $32^{\circ} 31' 45''$ ; diam.  $2'$ ; below the left arm of Sagittarius: faint, like the nucleus of a small comet.
  70. R.A.  $277^{\circ} 13'$ ; dec. S.  $33^{\circ} 31'$ ; diam.  $2'$ ; near the preceding, near four telescopic stars.
  71. R.A.  $295^{\circ} 59' 9''$ ; dec. N.  $18^{\circ} 13'$ ; diam.  $3' 30''$ ; between  $\gamma$  and  $\delta$  of the Arrow: very faint, and resolved into stars by Sir W. Herschel.
  72. R.A.  $310^{\circ} 20' 49''$ ; dec. S.  $13^{\circ} 20' 51''$ ; diam.  $2'$ ; above the tail of Capricorn: faint, but resolved into stars by Sir W. Herschel.
  73. R.A.  $311^{\circ} 43'$ ; dec. S.  $13^{\circ} 28' 40''$ ; near the preceding; three or four small stars, containing a little nebula.
  74. R.A.  $21^{\circ} 14'$ ; dec.  $15^{\circ} 39' 35''$ ; near  $\alpha$  in the string that connects the Fishes: very faint, but resolved into stars by Sir W. Herschel.
  75. R.A.  $298^{\circ} 17' 24''$ ; dec. S.  $22^{\circ} 32' 23''$ ; between Sagittarius and the head of Capricorn: composed of small stars with nebula. The astronomer Mechain makes it only nebulous.
  76. R.A.  $22^{\circ} 10' 47''$ ; dec. N.  $50^{\circ} 28' 48''$ ; diam.  $2'$ ; in Andromeda's right foot: composed of small stars with nebula; small and faint.
  77. R.A.  $37^{\circ} 52\frac{1}{2}''$ ; dec. S.  $57' 43''$ ; in the Whale: a mass of stars containing nebula.
  78. R.A.  $83^{\circ} 53\frac{1}{2}''$ ; dec. S.  $1' 23''$ ; diam.  $3'$ ; in Orion: a mass of stars with two bright nuclei, surrounded with a nebula.
  79. R.A.  $78^{\circ} 49'$ ; dec. S.  $24^{\circ} 43''$ ; below the Hare: a fine nebula bright in the center, and a little diffused, resolved into a mottled nebula by Sir W. Herschel.
  80. R.A.  $211^{\circ}$ ; dec. S.  $22^{\circ} 25'$ ; diam.  $2'$ ; between  $\gamma$  and  $\delta$  Scorpio: round, and bright in the center, like a comet.
  81. R.A.  $141^{\circ} 27' 44''$ ; dec. N.  $70' 7' 24''$ ; near the ear of the Great Bear: a little oval, bright in the center, and exhibiting a mottled nebula to Sir W. Herschel.
  82. R.A.  $141^{\circ} 29' 22''$ ; dec. N.  $70^{\circ} 44' 27''$ ; near the preceding: faint and elongated, with a telescopic star at its extremity; it showed a mottled nebula to Sir W. Herschel.
  83. R.A.  $291^{\circ} 8'$ ; dec. S.  $28^{\circ} 42\frac{1}{2}''$ ; near the head of the Centaur: very faint.
  84. R.A.  $183^{\circ} 30\frac{1}{2}''$ ; dec. N.  $14^{\circ} 7'$ ; in Virgo: bright in the center, and surrounded with nebula.
  85. R.A.  $183^{\circ} 35' 21''$ ; dec. N.  $19^{\circ} 24\frac{1}{2}''$ ; above and near Spica: very faint.
  86. R.A.  $183^{\circ} 46' 21''$ ; dec.  $14^{\circ} 10'$ ; in Virgo. the same as No. 84, and near it.
  87. R.A.  $184^{\circ} 56'$ ; dec. N.  $13^{\circ} 38'$ ; in Virgo: as luminous as the preceding.
  88. R.A.  $185^{\circ} 16'$ ; dec. N.  $15^{\circ} 38'$ ; in Virgo: very faint, and like No. 58.
  89. R.A.  $186^{\circ} 9' 36''$ ; dec. N.  $13^{\circ} 46' 49''$ ; near No. 87: very faint.
  90. R.A.  $186^{\circ} 27'$ ; dec. N.  $14^{\circ} 23'$ ; in Virgo: very faint.
  91. R.A.  $186^{\circ} 37'$ ; dec. N.  $14^{\circ} 57'$ ; above the preceding: fainter than the preceding.
  92. R.A.  $257^{\circ} 38'$ ; dec. N.  $43^{\circ} 22'$ ; diam.  $5'$ ; between the knee and left leg of Hercules: a beautiful nebula, bright in the center, and surrounded with great nebula: resolved into stars by Sir W. Herschel.
  93. R.A.  $113^{\circ} 48' 35''$ ; dec. S.  $23^{\circ} 19' 45''$ ; diam.  $8'$ ; between the Great Dog and Ship: a mass of small stars.
  94. R.A.  $190^{\circ} 10' 46''$ ; dec. N.  $42^{\circ} 18' 45''$ ; diam.  $2\frac{1}{2}''$ ; above Cor Caroli: bright in the center, with a diffused nebula.
  95. R.A.  $158^{\circ} 3' 5''$ ; dec. N.  $12^{\circ} 50' 21''$ ; in the Lion, above  $\iota$ : very faint.
  96. R.A.  $158^{\circ} 46\frac{1}{2}''$ ; dec. N.  $12^{\circ} 58''$ ; near the preceding: fainter than the preceding.
  97. R.A.  $165^{\circ} 18' 40''$ ; dec. N.  $56^{\circ} 13\frac{1}{2}''$ ; diam.  $2'$ ; near  $\zeta$  Great bear: very faint: another near it, and another near  $\gamma$ .
  98. R.A.  $180^{\circ} 50' 49''$ ; dec. N.  $16^{\circ} 8' 15''$ ; above the north wing of Virgo: very faint.
  99. R.A.  $181^{\circ} 55' 19''$ ; dec. N.  $15^{\circ} 37' 12''$ ; on the north wing of Virgo: brighter than the preceding: between two stars of the seventh and eighth magnitude.
  100. R.A.  $182^{\circ} 59' 19''$ ; dec. N.  $16^{\circ} 59' 21''$ ; in the ear of corn of Virgo: brighter than No. 98



101 R.A. 208° 52'; dec N. 55° 24' 25"; diam. 7'; between the left hand of Bootes and the tail of the Great Bear; very faint: discovered by Mechain: mottled nebulosity, according to Sir W Herschel.

102. Between *Omicron* in Bootes and *Iota* of the Dragon, very faint: discovered by Mechain.  
 103. Between  $\alpha$  and  $\delta$  Cassiopeia: a mass of stars.

## CHAPTER XIII.

### ON THE ABERRATION OF THE STARS, AND ON THEIR PROPER MOTIONS.

THE aberration of the fixed stars is a small change of place in the heavens which they seem to undergo, and by which they appear to describe, in the course of a year, an ellipsis or circle, the greatest diameter of which is about forty seconds. This remarkable fact was discovered, near the middle of the last century, by the celebrated Dr. Bradley, formerly Regius Professor of Astronomy at Greenwich.

In Chapter IV, when describing the mode of finding the parallaxes of the fixed stars, I have given a brief detail of the circumstances which led to this discovery, and the observations from which the aberration of the stars was deduced. Before perusing the following illustrations of this subject, it may not be improper for the reader to re-peruse what was there stated in reference to this point, particularly the illustration of this phenomenon, given in the description of Fig. 7 (p. 29, 30) It is there stated that Dr. Bradley and his friend Mr. Molyneux were very much perplexed at the result of their observations; since, instead of observing a motion indicating an annual parallax, they found a result directly opposite to what they expected. Many theories and conjectures were proposed to solve the appearances, but nothing satisfactory was elicited, until one day, when Dr. Bradley was enjoying the amusement of sailing about on the Thames, he observed that every time the boat tacked, the direction of the wind, estimated by the direction of the vane, seemed to change. This immediately suggested to him the cause of the phenomenon which had so much perplexed him, and he ultimately found it to be an optical illusion occasioned by a combination of the motion of light with the motion of his telescope while observing the polar stars—a discovery of no inconsiderable importance, and which will immortalize the name of this sagacious and indefatigable astronomer. He perceived that, if light is propagated in time, the apparent place of a fixed object will not be the same when the eye is at rest, as when it is moving in any other direction than that of the line passing through the eye and the object; and that when the eye is moving in different directions, the apparent place of the object will be different.

We see an object in consequence of the rays of light proceeding from it striking our eyes, and we see the place of the object in the direction in which they proceed. If light be in motion and the eye at rest, the object will appear in its real place, provided no refracting medium intervene; but if the eye be in motion, and this motion in a different direction from that of the rays of light, the object will not be seen in its true position. Let us suppose the earth, in its circuit round the sun, just arrived opposite to a fixed star, which sends off rays perpendicularly to the direction of the earth's motion. The eye of the spectator

meets the ray, and, as he perceives not his own motion, he supposes the light to be moving in a different direction, as when we sail along a winding river, certain objects on the banks appear to pass us in different directions. The eye misses the perpendicular ray, but meets an oblique one, and thence receives the impression of the light in the direction which results from this compound motion—namely, in the diagonal of a parallelogram, the sides of which represent the real motion of light. The spectator sees the star in its true place only when he is approaching it or receding from it in a straight line. When moving in any other direction, the star appears a little in advance of its true position; and these apparent changes in the situation of the heavenly bodies, occasioned by the annual motion of the earth, are distinguished by the *aberration of light*. They are common, to a certain extent, to all the celestial orbs, and are only more perceptible and striking in the case of the fixed stars. In consequence of this aberration during the revolution of the earth round the sun, the stars appear, according as they are situated in the plane of the ecliptic, or in its poles, or somewhere between them, in the first case, to deviate in a straight line to the right or left of their true place; in the second, to describe a circle, or something nearly approximating to it; and in the third, an ellipse about that point which observation determines to be their real situation.

This subject requires a little degree of attention in order to a clear understanding of it. Perhaps the following illustrations may, in some measure, render it plain to the general reader. Suppose *A B*, in the following figure, to represent a part of the orbit of the earth, and *C B* a ray of light descending from a star upon the earth's orbit *A B*;

Fig. 74.

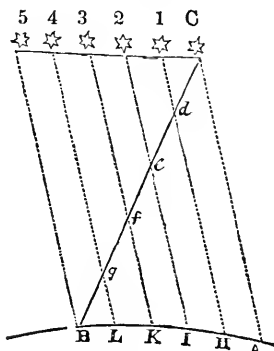

if the eye be at rest at *B*, the object will appear in the direction *B C*; but if the eye be moving



were not in motion, no such effect as that of the aberration of the stars could take place. If the earth were at rest, rays from a star would pass along the axis of a telescope directed to it; but were it set in motion with its present velocity, these rays would strike against the side of the tube, and it would be necessary to incline the telescope a little in order to see the star. The angle contained between the axis of the telescope and a line drawn to the true place of the star is just what we call its *aberration*, which could not take place if the earth were not in motion. That the earth is a planetary body moving through the depths of space along with the other planets of our system can be proved by numerous considerations; but the fact of the aberration of the stars exhibits this motion to our senses as clearly as if from a fixed point in the firmament we actually beheld it pursuing its course through the ethereal regions; so that the planetary nature of our globe, and the truth of the Copernican system, are no longer to be considered as mere hypotheses, but as facts susceptible of the strictest demonstration.

ON THE PROPER MOTION OF THE STARS.

To the eye of a common observer, all the stars and constellations in the heavens appear to preserve the same relative distances from each other; and even astronomers, not more than two centuries ago, could perceive no separate motions or variations in the positions of these distant orbs. From this circumstance they were denominated *fixed stars*, to distinguish them from the *planets*, which were observed to shift their positions and to move through different parts of the heavens. After the telescope was invented and applied to astronomical instruments, astronomers began to suspect that some of the stars had a slight degree of proper motion or change in their relative position, but it was a considerable time before such motions could be distinctly ascertained. These motions first began to be observed by Dr. Halley, and afterward by Lemonnier and Cassini, and were completely confirmed by Tobias Mayer, who compared the places of eighty stars as determined by Roemer with his own observations, and found that the greater part of them had a proper motion. He likewise suggested that the change of place he had observed among these stars might arise from a progressive motion of the sun toward one quarter of the heavens. La Lande deduced a similar opinion from the rotary motion of the sun, by supposing that the same mechanical force which gave it a motion round its axis, would also displace its center; and give it a motion of translation in absolute space. Of the same opinion was Sir W. Herschel, and he attempted, by a comparison of the proper motions of all the stars that had been ascertained, to determine the point of the heavens toward which the motion of the sun was directed, which he supposed was that occupied by the star *Zeta Herculis*.

If the sun really have a motion in absolute space directed toward any particular quarter of the heavens, it is obvious that the stars in that quarter must appear to recede from each other, while those in the opposite region, which the sun is leaving behind, must seem gradually to approach, in the same manner as when we walk through a forest, the ranges of trees to which we advance are constantly widening in their apparent distance from each other, while the distance of those we leave behind is gradually contracting. It does not, however, appear, from the most recent observations, that the direction in which the sun

or planetary system is moving is yet determined, although it is admitted that our system has a motion in space, and that the apparent proper motions of *some* of the stars *may* be the result of our being carried in a certain direction through absolute space by this motion. Such a motion, and even the direction of it, might be detected by such sidereal observations as those to which we allude, if we knew accurately the apparent proper motions of those bodies, and that they were independent of any *general motions* common to all the stars; but in the present stage of sidereal observation, it seems to be the general opinion of the most eminent astronomers, that no sufficient data are yet afforded for deducing definite conclusions on this subject.

The following table contains a few specimens of the annual proper motions of the stars in right ascension and declination, in seconds and decimals of a second, selected from the observations of Dr. Maskelyne. The first column contains the name of the star; the second, its magnitude; the third, its annual proper motion in right ascension; and the fourth, its motion in declination.

Names of the Stars.	Magnitude.	Annual Motion in R. A.	
		Seconds.	Seconds.
Capella	1	+ 0.21	+ 0.44 N.
Sirius	1	- 0.42	+ 1.04 S.
Castor	1	- 0.15	+ 0.44 S.
Procyon	1.2	- 0.80	+ 0.95 S.
Pollux	2	- 0.74	0.00
ε Leonis	1.2	- 0.57	+ 0.07 S.
ε Virginis	3	+ 0.74	+ 0.24 S.
Arcturus	1	- 1.26	+ 1.72 S.
Altair	1.2	+ 0.48	- 0.54 N.
α Lyrae	1	+ 0.23	- 0.27 N.
Antares	1	0.00	- 0.26 N.

In the above table, the sign + prefixed to the annual variation of right ascension, indicates that the variation is to be *added* to, and the sign - that it is to be *subtracted* from, the right ascension, to obtain the true place of the object at any given time.

It is found that not only among single, but even among *double* stars, such motions exist. While revolving round each other in the manner formerly described, they are at the same time carried forward through space with a progressive motion common to both, and without sensibly altering their distances from each other. One of the most remarkable of these is the double star 61 Cygni, formerly described, whose annual parallax and distance Professor Bessel appears to have lately determined.\* The two stars of which it is composed are nearly equal in apparent size, and they have remained constantly at the same distance of 15 seconds for at least fifty-seven years past, or since their positions began to be accurately observed. The annual proper motion of these two stars is found to be, according to Bessel, 5".123; which is the greatest annual proper motion of any of the stars which has yet been discovered; consequently, during the period now mentioned, they must have shifted their local situation in the heavens by a space equal to 4 minutes, 52 seconds; that is, a space equal to more than one-seventh of the apparent diameter of the moon. Such a change of place in bodies so immensely distant as 62,000,000,000,000 of miles indicates a prodigious rapidity of motion. "The relative motion of these stars and the sun,"

\* See chap. iv, p. 31, &c.

says Bessel, "must be considerably more than sixteen\* semidiameters of the earth's orbit;" that is 1,552,000,000 miles. They must therefore move at the rate of four millions two hundred and fifty-two thousand miles a day, and one hundred and seventy-seven thousand miles every hour; which is 68,000 miles an hour greater than the velocity of Mercury, which is the swiftest moving body in the planetary system. Here, then, we have a system of bodies of immense size moving with amazing velocity in different directions; for as these stars are doubtless suns, and consequently have a system of planets revolving round each, the planets must move round the sun to which they more immediately belong, and likewise round the other sun, or their common center of gravity, and at the same time they are carried forward to some distant region with the velocity now stated.

Among single stars, that which is marked  $\mu$  Cassiopeia, one of the smaller stars in that constellation, is marked as having the greatest proper motion of any yet ascertained. The amount of its annual motion is estimated at  $3\frac{3}{4}$  seconds, which in the course of a century will amount to 6 minutes 15 seconds, a space in the heavens equal to one-fifth of the apparent diameter of the moon.

If this star be reckoned at the same distance from the earth as the double star 61 Cygni, the velocity of its motion every day will be 3,112,000 miles; every hour, 130,000; and every minute, 2,160. The annual proper motion of Arcturus, in declination, is  $1''.72$ , which is nearly one-half the motion of  $\mu$  Cassiopeia; and a great many others are found by observation to be constantly progressing through the heavens by annual intervals of different degrees in extent, but generally smaller than those stated above. These changes of position in the stars cannot be perceived by the naked eye, and are consequently imperceptible to common observers; and even with the most accurate astronomical instruments some of them cannot be determined until after a lapse of years. Such motions give us reason to conclude that all the bodies in the universe are in perpetual motion, and many of them acted upon by separate forces, which carry them in different directions; and although some of these motions appear little more than just perceptible at the immense distance at which we are placed from them, yet it is probable that even the slowest motion of any of the stars is not less than at the rate of several thousands of miles every hour, indicating the operation of forces incomprehensible by the human mind.

## CHAPTER XIV.

### ON THE DESTINATION OF THE STARS; OR, THE DESIGNS THEY ARE INTENDED TO SUBSERVE IN THE SYSTEM OF THE UNIVERSE.

FOR many ages during the infancy of astronomy, the stars were considered chiefly as an appendage to the world in which we dwell. The crystalline sphere in which they were supposed to be fixed was regarded as only the canopy of man's terrestrial habitation, and the orbs with which it is diversified as so many brilliant spangles to adorn it, and to diffuse a few glimmering rays to cheer the darkness of the night. This celestial arch, in which the sun and moon are also placed, was supposed to revolve around us every twenty-four hours, producing an alternate succession of light and of darkness, while the earth, as the center of the universe, was considered as remaining in a state of perpetual quiescence. Above the visible heavens, where the stars are placed, nothing was supposed to exist except the throne of the Almighty and the abodes of the blessed; and such are still the contracted views of the majority of the inhabitants of our globe respecting that immense and glorious firmament with which we are surrounded.

It is true indeed that the stars, in a certain subordinate sense, were intended for the benefit of man; for we actually derive many advantages from their apparent motions and influence. They present to our view a scene of beauty and magnificence which enchants the eye and gratifies the imagination, and tends to raise the soul above groveling pursuits and terrestrial vanities. They cheer the shades of midnight and enable us to prosecute our journeys after the sun has left our hemisphere; without the influence of whose light our winter evenings would be shrouded in impen-

trable darkness, and not an object around us could be distinguished. In the absence of the moon all would be dark, as was chaos before light was formed to illuminate creation. Were the light of the starry orbs extinguished, instead of the grand and beautiful aspect now presented from above, the firmament would appear only like an immense blank, or a boundless desert, where nothing would be seen to stimulate human inquiry, or to display the attributes of the Creator. Those orbs are likewise of essential service to different departments of human life; they serve as guides to the traveler when journeying through vast and unfrequented deserts, and to the mariner when conducting his vessel from one country to another through the wide and pathless ocean. The Pole-star, on account of its apparently fixed position, has in every age been viewed with solicitous attention by the navigator; and before the invention of the compass it was his principal guide to direct his bark to the desired haven. In short, by means of the stars we have been enabled to determine the exact length of the day and of the year, the various subdivisions of time, the commencement and termination of the seasons, the circumference of the globe, the density of its materials, and the relative positions of places on every part of its surface; all which advantages it becomes man duly to appreciate, and with a grateful heart to adore the wisdom and goodness of Him "who made the sun to rule the day, and the moon and stars to rule the night," and who has rendered all his arrangements subservient to the happiness of his intelligent offspring.

But although the stars are of essential benefit to the inhabitants of our globe, yet we ought not

\* About  $16\frac{1}{2}$  See p. 32.

for a moment to imagine that this was the chief and ultimate end for which they were brought into existence. We know that they are bodies of immense size, the least of them many thousands of times larger than our globe. But such a number of magnificent globes were not necessary, in order to shed a few glimmering rays upon the earth; since the creation of an additional moon would diffuse far more light over our world than that which descends to the earth from all the visible stars in the firmament. And we know that the Creator does nothing in vain. It is the characteristic of infinite wisdom to proportionate means to the end intended to be accomplished; but in this case there would be no proportion between the means and the end—between creating a thousand globes of light of incalculable magnitude, and shedding a few glimmering rays to alleviate the darkness of midnight; and therefore this cannot be supposed the chief end of their creation, without impeaching the wisdom and intelligence of Him “who stretched out the heavens by his understanding.” Beside, whatever might be said in reference to the stars visible to the unassisted eye, it is impossible for a moment to conceive that those thousands, and ten thousands, and millions of stars, which are only visible through the most powerful telescopes, and whose light has never yet reached our globe, could have been created merely for the use of the inhabitants of this earth. Such a supposition must be forever discarded by every one who would entertain an honorable and consistent idea of the operations of infinite wisdom.

What, then, it may be asked, is the chief and ultimate destination of those magnificent globes? We may answer in general terms, that it is a destination corresponding to the magnitude and grandeur, and the intrinsic splendor of those distant bodies. It is the characteristic of every wise artist and architect, that he selects the most proper means to accomplish the end intended, and proportionates every part of a machine or edifice to all the other parts, so as to produce a harmony and unity of design. A philosophical instrument-maker, for example, in constructing an orrery does not make wheels of a hundred yards in diameter for carrying balls of less than an inch in diameter round a circle of only six feet in circumference; nor does a watchmaker employ two hundred wheels and pinions in the construction of a timepiece, when less than a dozen may suffice; nor does an architect make the portico of an edifice five hundred times larger than the whole structure. Were any individual to act in this manner, he would at once be denounced as utterly destitute of wisdom, and viewed as a fool or a maniac. Now, we are to consider the Almighty, in all his arrangements throughout the universe, as acting on the same general principle which directs a wise and intelligent artist in all his plans and operations; for wisdom is an essential attribute of the Divinity, and all his works, when minutely inspected, must necessarily display this perfection to intelligent minds. To suppose otherwise, to imagine for a moment either that he has not proportioned one part of the universe to another, or that the greater part of it was created for no use at all, would be the height of profanity and impiety, and would rob the eternal Majesty of Heaven of one of the most distinguishing attributes of his nature. Bearing this principle in mind, we are necessarily led to the conclusion—a conclusion as certain as any mathematical demonstration—namely, that the benefit of the inhabitants of our globe was *not* the chief or ultimate design

for which the stars were created, but that the Deity had a higher and more expansive design to accomplish in their formation. We do not pretend to fathom *all* the subordinate designs the Creator may have had in his view in the creation of the stars, or of any other object; but as he has endowed us with rational faculties for the investigation of his works, it is evident that he intended we should be able to discover *some* of the main and leading designs which he intended to accomplish in the formation of the great bodies of the universe.

We therefore maintain that one of the grand and leading designs of the creation of the stars was, that they should serve as *suns* to give light to other worlds and systems with which they are more immediately connected. This proposition I have all along taken for granted in the preceding pages, and shall now adduce a few arguments to elucidate and support it.

1. *They all shine by their own native light.*

This is the peculiar characteristic of a sun in distinction from the planetary globes, which all shine with *reflected* light, derived from the luminous center around which they revolve. The immense distance at which the nearest stars are placed from our globe is a clear proof that they shine, not with borrowed, but with inherent splendor; for reflected light from such a distance would be entirely dissipated ere it could reach our eyes. This likewise appears from actual observation, and from a comparison of the brilliancy of the fixed stars with that of the planets, in which there is found a striking difference. Mercury and Venus are the two planets which revolve in the immediate neighborhood of the sun, and consequently derive from him a greater portion of light than any of the other planets; yet it is found that the luster of the star *Sirius*, and even that of *Capella*, is much more brilliant than that of either Mercury or Venus; and it is demonstrably certain that both these stars are situated far beyond the orbit of Uranus; and therefore, if they derived their light from the sun, they behoved to be incomparably more obscure than any of the planets. The luster and brilliancy which the fixed stars exhibit when viewed with telescopes of large apertures and powers is exceedingly striking. Sir W. Herschel seldom looked at the larger stars through his forty-feet telescope, because their blaze was injurious to his sight. At one time, after sweeping a portion of the heavens with that instrument, he tells us that “the appearance of *Sirius* announced itself at a great distance like the dawn of the morning, and came on by degrees, increasing in brightness, until this brilliant star at last entered the field of the telescope with all the splendor of the rising sun, and forced me to take my eye from the beautiful sight.” These and other circumstances clearly show that the stars are indued with native splendor, and are not dependent on any other luminaries for the brilliancy they display, and consequently are fitted to act as suns for the illumination of opaque globes with which they are more immediately connected.

2. *They are placed at an immense distance from our earth and from one another, and consequently it is impossible that they could derive their luster from our sun; for the sun in his present situation could afford them no more light than a single star transmits to our globe; and to some of the more distant stars his rays would be altogether invisible. And if the sun cannot be supposed to enlighten any of those orbs, from the distance at which he is placed, there is no other body known*

to us whence their light may be derived, if they do not shine with their own native splendor.

3. *They are bodies of immense magnitude.* We have already shown, both from mathematical considerations and popular illustrations, that the stars are unquestionably at a very great distance from our globe, a distance which is almost incomprehensible. (Chap. IV.) Their bulk must therefore be very great. If they were no larger than the globe on which we live, they would be altogether invisible, even although they shine with their own native light. Few of them can be considered as much less than our sun, and the greater number of them are in all probability much larger; they are therefore fitted by their enormous size, and their consequent attractive power, to be the centers of systems of planetary worlds, and to diffuse around them to an immense distance a splendid illumination. But it would be absurd to suppose that such a number of vast luminous globes, placed at such immense distances from each other, and from the earth, could have been created solely for the benefit of the inhabitants of our world; for it would argue a want of wisdom in not proportioning means to ends; since a single star of the one-thousandth part of its present bulk, placed within a million of miles of the earth, would afford us far more light than all the stars put together.

4. Were we removed to the distance only of the nearest stars, our sun would appear no larger than one of those twinkling orbs, and from some of them he would disappear altogether; at most, he would appear only as *one* of the small stars which deck the firmament, and probably one only of the fifth or sixth magnitude; consequently all the planets of our system would entirely disappear. Even Jupiter and Saturn, though each of them is a thousand times larger than the earth, would be quite invisible, by reason of their comparative smallness and their shining only by *reflected* light. The system to which we belong cannot therefore be supposed to have any *immediate* connection even with the nearest stars; and these stars must be considered as having appropriate purposes to fulfill in their own immediate sphere.

5. *The stars, in point of number, size and splendor, constitute almost the whole universe, at least, so far as it has been unfolded to our view.* The bodies which compose the planetary system contain a mass of solid matter about 240 times larger than that of the earth, and the sun is about 500 times greater than the whole of them taken together. But this system, great as it appears in the eyes of mortals, is but as a diminutive ball, or even as a mere point, when compared with the myriads of stars which the firmament displays, and which the telescope has brought to view. These innumerable globes of light were created for *use*—to subservise important purposes in the plan of the Divine administration. They were not launched through the spaces of infinity at random, merely to display the energies of Omnipotence, and to light up the wilds of immensity with a useless splendor. Such a supposition would be derogatory to the attributes and character of the All-wise Creator, and would distort all the views we ought to entertain of a Being possessed of infinite perfection. Those immense bodies must therefore be conceived as intended chiefly to diffuse their light and splendor over worlds with which they are more immediately connected, and for the ultimate design of communicating happiness in various forms to the different orders of beings with which they may be replenished. What other subordinate ends they

may accomplish in the grand scheme of the universe, beside the advantages we derive from them, is beyond our province to determine. It is not improbable, however, that every star or system, whether single, binary, or ternary, may have a subordinate end to serve to every other system, as forming parts of one whole under the government of Infinite Wisdom. As we derive advantages from these orbs, distant as they are, and as they diversify the ceiling of our earthly habitation with a splendid decoration, so they will likewise adorn the firmament of other systems, and display to the view of their inhabitants both the energies of Omnipotent Power and the manifold wisdom of God.

6. *We have some direct indications that the fixed stars are in reality suns.* It forms no argument against the idea of the stars being the centers of systems, that we have hitherto been unable to detect any of their revolving planets; for unless such planets be far beyond the magnitude of those belonging to our system, and unless their surfaces be fitted to reflect the rays of light with extraordinary brilliancy, we could not expect them to be visible at the remote distance at which we are placed, since the stars themselves appear only as shining points. But certain phenomena which have been observed, chiefly within the last century, give indication of the solar nature of the fixed stars. In the first place, there are phenomena which indicate that some of them at least, like our sun, have a rotation round their axes. In Chapter VII we have given a brief view of the phenomena of *variable* stars. One of these, named *Algol*, is found *regularly* to pass through a change of brightness from the second to the fourth magnitude, and again to its original brightness in two days and about twenty-one hours. The star  $\epsilon$  Lyrae passes through a periodic variation, from the third to the fifth magnitude, in six days and nine hours. A star in Hercules varies its luster periodically, in the course of sixty days and six hours. A star in Sobieski's shield changes from the fifth to the seventh or eighth magnitude, and returns to its greatest brightness, in a period of sixty-two days. These and many other stars give pretty evident indications of a rotation round their axes. Their periodic changes are *exact* and *regular*; and, in order to account for the phenomena, we have only to suppose that one of their hemispheres is either covered with large dark spots, or is encompassed with a medium which prevents it from emitting so much light to our eyes as the other, and that each hemisphere is presented to our view in alternate succession. Our sun, indeed, would not exhibit any sensible variation of luster at the distance of the stars, notwithstanding some large spots on his surface; but we have no reason to conclude that the stars, although they are all luminous bodies, are exactly alike in every part of their constitution, since variety appears to be a characteristic of all the arrangements in the universe. The darker hemisphere of the stars to which we allude may produce a change of illumination, which will form an agreeable vicissitude to the inhabitants of the worlds which roll around them, and which may produce an effect somewhat analogous to that which is produced by the alternate shining of a white and a yellow sun, as in the case of some of the double stars (see pp. 52, 53.)

Again, there are stars whose periods of variable luster are much longer than those now stated. Some of them pass through their periodic changes in 331 days, some in 494 days, and others not until after the lapse of eighteen years. Such

changes, at east in some instances, may be accounted for by the intervention of opaque revolving bodies, or planets of a large size, passing directly between our eye and the stars, when revolving through that half of their orbits which lies next the earth. It is almost certain that either the one or the other of the circumstances now mentioned is the cause which produces the phenomena of variable stars, and in either case a strong presumption is afforded of the reality of other planetary systems. If *rotation* be the cause of the changes alluded to, the analogy between our sun and the stars is almost verified, for the most eminent philosophers have always considered that the rotation of an orb is necessarily connected both with motion in space, and with the existence of revolving planets. If such changes arise from the interposition of opaque globes, as is highly probable in some of the cases we have stated, then we have direct evidence that the stars are in reality the centers of systems, and that their planets are constructed on a scale of magnificence far surpassing that of our solar system. (See Ch. VII, pp. 43, 44.) It is highly probable that both the causes to which we have now adverted operate in producing the phenomena of variable stars. Those whose periodic variations are the shortest may be produced by rotation, and those in which years are requisite to accomplish all the changes, may arise from the intervention of very large opaque revolving bodies.

It has been surmised by some astronomers that certain very small stars which accompany larger ones probably shine by reflected light. Sir John Herschel, a few years ago, called the attention of astronomical observers to this point. The stars to which he has requested particular attention are such as the following:—*Ursæ Majoris*,  $\gamma$  *Hydræ*,  $\alpha$  *Geminorum*;  $\alpha$  2 *Canceri*,  $\alpha$  2 *Capricorni*, and several others. *Iota Ursæ* is a star of the third or fourth magnitude, in the fore foot of the Great Bear: right ascension, 8h. 46' 54"; north declination,  $47^{\circ} 51' 20''$ . *Gamma Hydræ* is a star of the fourth magnitude, about thirty-five degrees southeast from *Regulus*, and about twenty-nine degrees west by south from *Spica Virginis*: right ascension, 11h. 16' 57"; south declination,  $16^{\circ} 42'$ . *Kappa Geminorum* is a star of the fourth magnitude, situated about three degrees and a half south of *Pollux*: right ascension, 7h. 33' 38"; north declination,  $24^{\circ} 49'$ . The star  $\alpha$  2 *Capricorni* is of the third magnitude, about twenty-two degrees south by east of *Altair*, and about two degrees and a half north of  $\zeta$  *Capricorni*, &c. It is to the very small and point-like stars which accompany these that the attention is to be directed; they are minute points of light which can only be perceived by telescopes of considerable power. Some of these are suspected as shining with reflected light; and if this point could be ascertained, it would form a *direct proof* of planets circulating around stars and enlightened by their beams. We have reason to hope, from the increase of astronomical observers, from the accuracy with which sidereal observations are now conducted, and from the improvements of which the telescope

is still susceptible, that this interesting fact, will ere long, be determined by ocular demonstration; and when such a discovery shall have been made, the telescope, which has already disclosed so many wonders, will then have performed one of its most sublime and mighty achievements.

In the meantime, we have no reason to entertain the least doubt that the stars are in reality *suns* and the distributors of light to other worlds any more than we ought to doubt of the motion of the earth, because we have never, from a fixed point in the firmament, beheld it wheeling its rapid course through the ethereal spaces around the sun. Since the stars cannot, with the least show of reason, be supposed to have been created chiefly for the use of our globe, it is as certain as moral demonstration can make it, that they were principally intended to fulfill a higher and a nobler purpose, and that this purpose has a respect to the accommodation and happiness of intelligent existence, either in the stars themselves or in worlds which revolve around them; for the Creator and Governor of the universe must be considered, in all his arrangements, as acting in perfect consistency with those perfections of his nature with which he is eternally and essentially invested. But to suppose the innumerable host of stars to be only so many vast insulated globes, hung up to irradiate the void spaces of infinitude, would be repugnant to all the conceptions which reason and revelation lead us to form of a Being of infinite perfection.

If then, the fixed stars are the centers of light and influence to surrounding worlds, how immense must that empire be over which the moral government of the Almighty extends!—how expansive the range, and how diversified the order of planetary systems!—how numerous beyond calculation the worlds which incessantly roll throughout the immensity of space! What countless legions of intellectual beings, of every rank and capacity must crowd the boundless dominions of the King eternal, immortal, and invisible!—and how glorious and incomprehensible must he be whose word caused this vast fabric to start into existence, and who superintends every moment the immensity of beings with which it is replenished! In attempting to grasp such scenes the human mind is bewildered and overwhelmed, and can only exclaim, "GREAT AND MARVELOUS ARE THY WORKS, LORD GOD ALMIGHTY."

"Seest thou these orbs that numerous roll above?  
Those lamps that nightly greet thy visual powers  
Are each a bright capacious sun like ours.  
The telescopic tube will still desery  
Myriads behind that 'scape the naked eye,  
And farther on a new discovery trace  
Through the deep regions of encompassed space.  
If each bright star so many suns are found  
With planetary systems circled round,  
What vast infinitude of worlds may grace,  
What beings people the stupendous space?  
Whatever race possess the ethereal plain,  
What orbs they people, or what ranks maintain?  
Though the deep secret heaven conceals below,  
One truth of universal scope we know;  
Our nobler part, the same ethereal mind,  
Relates our earth to all their reasoning kind,  
One Deity, one sole creating cause,  
Our active cares and joint devotion draws."

## CHAPTER XV.

### ON UNKNOWN CELESTIAL BODIES—ON METEORIC PHENOMENA—AND ON SHOOTING STARS.

WE are not to imagine that we have yet discovered the greater part of the bodies which exist in those spaces whose range lies within the reach of our telescopes. All the discoveries which have hitherto been made in the heavens have been owing to the *light* emitted by very distant orbs having been concentrated on the eye by the magnifying and space-penetrating power of the telescope; but it is not improbable that there are numerous bodies within the circuit of the visible heavens which send forth no rays of light susceptible of being refracted or reflected to the eye by our finest instruments. Some of the largest bodies in the universe may either be opaque globes, or so slightly illuminated that no traces of their existence can ever be perceived from the region we now occupy. The greater part, if not the whole, of the orbs which have been described in the firmament, with the exception of the planets and comets of our system, are globes which shine with their own inherent luster, without which their existence would have been to us forever unknown. We are not warranted to call in question the existence of any class of bodies merely because our limited organs of perception and our situation in the universe prevent us from perceiving them. We have never yet beheld the planets which doubtless circulate around other suns, although there can be no question that such bodies really exist; and there may be opaque globes of a size incomparably larger than either planets or suns, which may serve as the centers of certain systems, or for some other important purposes to us unknown; for all that we have yet explored of the distant regions of creation is but the mere outskirts of that boundless empire which stretches out on every hand toward infinity. It is not unreasonable to believe that the number of magnificent bodies imperceptible to our organs of vision may far exceed all that we have hitherto discovered either by the naked eye or the telescope, even within the compass of that region which lies open to human inspection.

It has been remarked by La Place, that "a luminous star of the same density as the earth, and whose diameter should be two hundred and fifty times larger than that of the sun, would not, in consequence of its attraction, allow any of its rays to arrive at us." "A star which, without being of this magnitude, should yet considerably surpass the sun, would perceptibly weaken the velocity of its light, and thus augment the extent of its aberration." It is therefore possible that the largest *luminous* bodies in the universe, if their internal structure be composed of dense materials, would be invisible to us, in consequence of their great attractive power preventing their light from reaching the system to which we belong. In Chapter XII, I have given a brief view of the ideas entertained by Lambert respecting the arrangement of the universe into distinct systems of stars which have a more immediate connection with one another in consequence of the law of

mutual gravitation, and whose views have been partly confirmed by the discoveries of Herschel. This illustrious mathematician and astronomer endeavors to prove, by an induction of facts and reasonings, that, in order to the stability of those systems, it is necessary, on the principles of universal gravitation, that there be a large central body, around which all the individuals which compose the system revolve. There is no necessity that such a central body should possess original or undervived light. The fixed stars do not stand in need of it; and as for itself, if it require illumination, it will receive it from the suns that are more immediately adjacent. As to the *magnitude* of such a center, Lambert estimates that the central body of the system to which we belong must have a diameter at least equal to the whole circumference of the orbit of Saturn. "The magnitude of those bodies," he says, "ought not to alarm us, for, in the first place, we have nothing to do with their bulk, but with their density or quantity of matter by which the law of gravitation is regulated. We have no idea of the density of matter that is not porous; perhaps gold, the most dense of terrestrial substances, would be found a mere sponge compared with such a central body. Beside, nothing is great or small in immensity; and since on the wing of light we can traverse the vast regions of the heavens, matter and volumes ought no longer to excite our astonishment. Beginning with the satellites, even suns are but bodies of the first magnitude; the centers of the fixed stars, of the fourth; those of groups of systems, of the fifth, and so of the rest."

Lambert supposes that since such bodies must be of enormous bulk, and illuminated beside by one or more fixed stars, it might be possible to perceive the one which belongs to our own system, either in whole or in part, with the help of the telescope; that its apparent diameter may be very considerable; that, however weak its reflected light, it may not be enfeebled to such a degree as to be rendered imperceptible; that, being enlightened by one or more suns, it ought to present phases analogous to those of the moon; that such a central body ought to extend its influence even to the extremities of its system, and consequently ought to appear under a sensible diameter, or at least be visible by the telescope; and that as the attractive force of a body decreases as the square of the sine of its apparent semidiameter, so this apparent semidiameter cannot be invisible in any place to which its attractive force and its sphere of activity extend. Without sanctioning all the opinions which this ingenious mathematician has thrown out on this point, we may admit that the subject is worthy of special attention, and might be kept in view when we are exploring the heavens with our best telescopes. What if some of the planetary nebulae be bodies of a nature similar to those to which we have now alluded?

If opaque globes of a prodigious size exist throughout the regions of the firmament, as there



is reason to believe, they would afford us a clue for unraveling certain phenomena which have hitherto remained in some degree inexplicable. Stars have appeared all at once, and, after having shone for a year or more with a brilliant light, have gradually disappeared. Certain stars are found to pass through regular variations of luster, and for a certain period entirely disappear, but after a lapse of a certain number of months or days reappear, and resume their former brightness. On the supposition that opaque bodies exist nearly in the direction of such stars, some of these phenomena would admit of an easy explanation. Their appearing and disappearing might be nothing more than an occultation or an eclipse, caused by the interposition of the opaque globe between our eye and the star. This would, indeed, suppose *motion* to exist either in the opaque body, or in the star, or in the eye of the observer; and perhaps the annual motion of the earth, or the motion of the sun in absolute space, might contribute, in a certain degree, to produce the effect. Motion, of some kind or other, must necessarily be supposed, in order to account for the phenomena of variable stars, whatever hypothesis we may adopt for their explanation; but as nothing decisive can be stated on this subject, in the meantime I shall proceed to the consideration of some meteoric phenomena which are now supposed to have a connection with certain moving bodies in the heavens.

#### METEORIC PHENOMENA AND SHOOTING STARS.

In my volume entitled "Celestial Scenery," when describing the small planets Vesta, Juno, Ceres, and Pallas, I have given a detail of certain facts respecting the fall of large masses of solid matter from the higher regions of the atmosphere, usually denominated *meteoric stones*, which, there is every reason to believe, descend from regions at a considerable distance, and even beyond the sphere of the moon. Such phenomena seem to indicate the probability that certain opaque bodies, of different dimensions, are revolving through space in certain regions within the limits of our system. "Nor is this," says Mrs. Somerville, "an unwarranted presumption; many such do come within the sphere of the earth's attraction, are ignited, by the velocity with which they pass through the atmosphere, and are precipitated with great violence, upon the earth. The fall of meteoric stones is much more frequent than is generally believed. Hardly a year passes without some instances occurring; and if it be considered that only a small part of the earth is inhabited, it may be presumed that numbers fall in the ocean, or on the uninhabited part of the land, unseen by man. They are sometimes of great magnitude; the volume of several has exceeded that of a body of seventy miles in diameter. One which passed within twenty-five miles of us was estimated to weigh about 600,000 tons, and to move with a velocity of about twenty miles in a second, a fragment of it alone reached the earth. The obliquity of the descent of meteorites, the peculiar substances they are composed of, and the explosion accompanying their fall, show that they are foreign to our system."

But, without resuming the consideration of this particular phenomenon, there is another which of late years has excited a considerable degree of attention, and which may proceed from a cause somewhat similar, to which I shall chiefly direct the attention of the reader—namely, the phenomenon of *shooting or falling stars*. This phenom-

non, though most frequently observed in tropical regions, is common in all parts of the earth, and has been seen in almost every season of the year. A shooting star seems to burst from a clear sky, and to dart across the heavens with a long train of light, which in a few seconds leaves no trace behind. Dr. Burney, of Gosport, for several years kept a record of such of these bodies as came under his own observation, and found that in the year 1819 there were 121, and in 1820 about 131; but a much greater number than these would doubtless be perceived could we detect all that make their appearance in the sky, the greater proportion, in all probability, being visible only during the hours usually allotted to sleep. Various opinions have been entertained respecting the cause of these appearances. Beccaria was of opinion they were occasioned by electricity, and brought forward the following facts as corroborative of his hypothesis:—About an hour after sunset, he and some friends that were with him observed a falling star directing its course directly toward them and apparently growing larger and larger, but just before it reached them it disappeared. On vanishing, their faces, hands, and clothes, with the earth and all the neighboring objects, became suddenly illuminated with a diffused and lambent light. During their surprise at this appearance, a servant informed them that he had seen a light shine suddenly in the garden, and especially upon the streams that he had been throwing to water it; when, sending up an electrical kite into the atmosphere, he likewise observed a quantity of electric matter about the kite, which assumed the appearance of a falling star. Whatever be the cause of shooting stars, it is pretty evident that they have their origin at a very considerable elevation above the earth. Brydone informs us that, from the top of Mount Etna, he noticed some of these meteors, "which still appeared to be as much elevated above us as when seen from the plain; so that in all probability those bodies move in regions much beyond the bounds which some philosophers have assigned to our atmosphere."

The most striking and remarkable form in which shooting stars have appeared is that of "meteoric showers," when thousands of those bodies have appeared to sweep along at once, and in continued succession for several hours, so that almost the whole visible canopy of the sky seemed to be in a blaze. As this phenomenon has recently excited considerable attention among philosophers, and as it is now generally considered as connected with some moving bodies in the heavens, I shall, in the first place, give a detail of some of the more remarkable circumstances with which it has been attended, as described by those who were eye-witnesses of the scene. One of the most remarkable displays of the phenomena to which we allude is that which was seen on the evening of the 12th and the morning of the 13th of November, 1833, in the United States of America. The following account of it is abridged from the *New York Commercial Advertiser* of November 13, 1833:

"The sky was remarkably clear on the night of this remarkable phenomenon. Some time before twelve o'clock, the meteors so frequently seen on summer evenings, called *shooting stars*, were observed to fall with unusual frequency and splendor. They continued from that hour to flash athwart the skies more and more, until they were eclipsed by the glories of the rising sun this morning. From four to six they were most numerous and refulgent. Within the scope that the eye could contain, more than twenty could be seen at

a time shooting (save upward) in every direction. Not a cloud obscured the broad expanse, and millions of meteors sped their way across it on every point of the compass. Were it possible to enumerate them in the swiftness of their arrowy haste, we might venture to say that for the space of two hours, intervening between four and six, more than a thousand per minute might have been counted. Their coruscations were bright, gleamy, and incessant, and they fell thick as the flakes in the early snows of December. In one instance we distinctly heard the explosion of a meteor that shot across to the north-west, leaving a broad and luminous track; and witnessed another which left a path of light that was clearly discernible for more than ten minutes after the ball, if such it be, had exploded. Its length was gradually shortened, widening in the center, and apparently consisted of separate and distinct globules of light, drawn around a common center, glimmering less and less vividly until they finally faded in the distance. Compared with the splendor of this celestial exhibition, the most brilliant rockets and fireworks of art bore less relation than the twinkling of the most tiny star to the broad glare of the sun. The whole heavens seemed in motion, and never before has it fallen to our lot to observe a phenomenon so magnificent and sublime."

Various similar accounts of the same phenomena were given in the *Philadelphia*, *Hartford*, *Boston*, and other newspapers of the same date, of which the following are extracts:

"From a point in the heavens, about fifteen degrees south-easterly from our zenith, the meteors darted to the horizon in every point of the compass. Their paths were described in curve lines similar to those of the circles of longitude on an artificial globe. They were generally short in their course, resembling much an interrupted line, thus ————. They ceased to appear when within ten degrees of the horizon. I did not see a single meteor pass the meteoric pole I have described, nor one pass in a horizontal direction. Several of them afforded as much light as faint lightning. One in the north-east was heard to explode with a sound like that of the rush of the distant sky-rocket. Millions of these meteors must have been darted in this shower. The singularity of this meteoric shower consisted in the countless number of the celestial rockets, and more especially in their constant uniform divergence from near the zenith."

The following was an account sent by Professor Thomson, of Nashville, to Professor Olmsted, of New Haven, of the meteors which appeared November 13, 1833, as seen in the State of Mississippi:—"About an hour before daylight I was called to see the falling meteors; it was the most sublime and brilliant sight I had ever witnessed. The largest of the falling bodies appeared about the size of Jupiter or Venus when brightest. The sky presented the appearance of a shower of stars, which many thought were real stars and omens of dreadful events. I noticed the appearance of a *radiating point*, which I conceived to be the vanishing point of straight lines as seen in perspective. *This point appeared to be stationary.* The meteors fell to the earth at an angle of about seventy-five degrees with the horizon, moving from the east toward the west." The following is from a writer in the *Boston Christian Register*:—"My first attention was to determine the center or point from which the meteors started, which, from the place where I stood (lat. 42° 45' N.), appeared in the Lion's heart, near Regulus. There is one thing that I have not seen noticed by any that have

written, and which could not have been noticed by me had I not kept my eye on the center or point from whence the meteors all shot forth for a considerable time, and that was an appearance of a star less at first than the stars of the constellation by which it was surrounded, but it would increase until it was much larger than the stars, then totally disappear from ten to fifteen minutes, and then appear again; but the meteors shot forth in greater numbers in the interval between the appearances above-mentioned."\*

It is worthy of particular notice, that the point from which the meteors seemed to emanate was observed, by those who fixed its position among the stars, to be in the constellation Leo; and, according to their concurrent testimony, this *radiant* point was stationary among the stars during the whole period of observation—that is, it did not move along with the earth in its diurnal revolution *eastward*, but accompanied the stars in their apparent progress *westward*, which proves the elevation of the meteors to be far beyond our atmosphere. The following cut represents the appearance of these meteors for several hours, as seen at

Fig. 76.

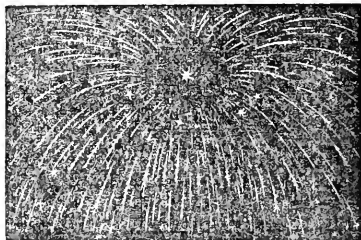

Boston, New York, Philadelphia, and other places in the eastern parts of the United States. It is copied from one of the American periodicals published about the time when those phenomena appeared.

Meteoric phenomena nearly resembling what has been now described, have occurred at several former periods. One remarkable instance of what was called "showers of fire," occurred over eighty years ago in South America. At Quito, so many falling stars were seen above the volcano of Galyambo, that the inhabitants were led to imagine the mountain to be in flames. The people assembled in the plain of Exico, and a procession was about to set out in consequence from the convent of St. Francis, when they discovered the phenomenon to be occasioned by meteors which ran along the skies in all directions.

A more extensive and remarkable phenomenon of this kind occurred in the night of the 12th of November, 1779. Of this appearance, as it was seen at Cumana, an accurate account has been given by M. Humboldt and M. Bonpland. It occurred toward the morning, when thousands of meteors, comets, fire-balls, or falling stars, as they were variously denominated, succeeded each other during four hours. Their direction was from north to south. They rose in the horizon at east-north-east, followed the direction of the meridian, and fell toward the south. There was little wind, and this from the east. No trace of clouds was seen. There was not a space in the firmament

\* This astonishing exhibition covered a very considerable part of the earth's surface. It has been traced from the longitude of 61° in the Atlantic Ocean to 100° in Central Mexico, and from the North American lakes to the West Indies.

equal in extent to three diameters of the moon which was not filled with burning stars. They were of different sizes; they left luminous traces of from five to ten degrees in length. The appearance of these traces continued seven or eight seconds. Many of the stars had a distinct nucleus as large as the apparent disc of Jupiter. The largest were from  $1^{\circ}$  to  $1^{\circ} 13'$  in diameter. Their light was white, and they seemed to burst as by explosion. They were seen by all the inhabitants of Cumana, the oldest of whom asserted that the great earthquakes of 1766 were preceded by similar phenomena.

It is a circumstance worthy of particular notice, that these meteoric showers have taken place chiefly on the 12th and 13th of November, and hence they are now distinguished by the name of the *November Meteors*. Captain Hammond gives the following account of shooting stars seen at Mocha, on the Red Sea, November 13th, 1832, the day and month on which they have most generally been seen:—"From one o'clock, A. M., until after daylight, there was a very unusual phenomenon in the heavens. It appeared like meteors bursting in every direction. The sky at the time was clear, the stars and moon bright, with streaks of light and thin white clouds interspersed in the sky. On landing in the morning, I inquired of the Arabs if they had noticed the above. They said they had been observing it most of the night. I asked them if ever the like had appeared before? The oldest of them replied that it had not."

On the morning of the 12th of November, 1799, a remarkable phenomenon of this kind was seen by Mr. Ellicot, near Cape Florida, which he thus describes:—"The phenomenon was grand and awful; the whole heavens appeared as if illuminated with sky-rockets, which disappeared only with the light of the sun after daybreak. The meteors, which at any one instant of time appeared as numerous as the stars, flew in all possible directions, except from the earth, toward which they all inclined more or less, and some of them descended perpendicularly over the vessel we were in, so that we were in constant dread of their falling on us." The same appearances were observed on the same night at Santa Fe, Cumana, Quito, and Peru, in South America, as far north as Labrador and Greenland, and as far east as Weimar in Germany; thus having been visible over an extent on the globe of  $64^{\circ}$  in latitude, and  $94^{\circ}$  of longitude. Meteoric showers were also seen on the morning of the 13th of November, 1831, in the Ohio country, and along the coast of Spain.

Flights of shooting stars, more or less numerous, have been seen in different places, both in Europe and America, at the same period—namely, the 13th of November, in the years 1834, 1835, 1836, and 1837, so that they are now considered as a regular periodical phenomenon. In a letter I received, in 1837, from Elijah H. Burritt, Esq., A. M., a scientific gentleman in the state of Connecticut, and a correspondent of Professor Olmsted, he has the following notice on the subject: "With respect to the shooting stars, I believe, Professor Olmsted is now very strong in the belief that they are exactly *periodical* and *annual*. The recurrence of this singular phenomenon on the morning of the 13th of November, 1836, and very nearly at the same hour.—the radiation of the meteors from the same point of the heavens, differing only one half a degree (as did those of 1834), namely  $145^{\circ}$  right ascension in the face of Leo, and all the attending phenomena being the same, though upon a scale less magnificent,—settle the question as to its being a regular and

annual phenomenon. According to his notion, the zodiacal light is an attribute of the same cause, or an emanation from the same radiant. Accordingly, my friend Dr. Olmsted was fortunate enough to see just so much of the zodiacal light last May as to enable him to identify it with the phenomena of November, 1834, except that it was in the other node."

One of the most remarkable circumstances attending this display, in 1833, was, that the meteors all seemed to emanate from one and the same point, a little south-east of the zenith. Following the arch of the sky, they ran along with immense velocity, describing in some instances an arc of  $30^{\circ}$  or  $40^{\circ}$  in a few seconds. On an attentive inspection, it was seen that the meteors exhibited *three* distinct varieties; the *first* consisting of *phosphoric lines*, apparently described by a point; the *second*, of large *fire-balls* that at intervals darted along the sky, leaving luminous trains which occasionally remained in view for a number of minutes, and in some cases for half an hour or more; the *third*, of undefined *luminous bodies*, which remained nearly stationary in the heavens for a considerable time. Those of the first variety were the most numerous, and resembled a shower of fiery snow driven with inconceivable velocity. The second kind appeared more like falling stars,—a spectacle which was contemplated by certain beholders with great amazement and terror. They were sometimes of enormous size. One of them seen in North Carolina appeared larger than the full moon rising, and its light rendered even small objects visible. The same ball, or a similar one, seen at New Haven, passed off in a north-west direction and exploded a little northward of the star Capella, leaving a train of peculiar beauty. The line of direction was at first nearly straight, but it soon began to contract in length, to dilate in breadth, and to assume the figure of a serpent scrolling itself up until it appeared like a luminous cloud of vapor floating gracefully in the air, where it remained in full view for several minutes. Of the third variety, the following are examples:—At Poland, State of Ohio, a luminous body was distinctly visible in the north-east for more than an hour. It was very brilliant, in the form of a *pruning hook*, and apparently twenty feet long and eighteen inches broad. It gradually settled toward the horizon until it disappeared. At Niagara Falls, a large luminous body, shaped like a *square table*, was seen near the zenith, remaining for some time almost stationary, emitting large streams of light.

The recurrence of this wonderful phenomenon at the same season of the year soon attracted the attention of the philosophers of Europe, and they resolved to watch more particularly the aspect of the nocturnal heavens in the month of November. The celebrated M. Arago made arrangements to procure simultaneous observations from the different parts of France, for the night between the 12th and 13th of November, 1836. The following is the substance of the report which was published of these observations. The places at which observations were made, and the number of meteors counted, were as follows:

Paris, at the observatory . . . . .	170
Dieppe, 100 miles north-west of Paris . . . . .	36
Arras, 100 miles north of Paris . . . . .	27
Strasbourg, 250 miles east of Paris . . . . .	85
Von Altemare, 260 miles south-east of Paris . . . . .	75
Angou, 180 miles south-west of Paris . . . . .	49
Rochefort, 260 miles south-south-west of Paris 23	
Havre, 120 miles west of Paris . . . . .	300

Beside these positive observations, information was received of similar phenomena having been observed at other places. In the neighborhood of Tours, for example, the peasants declared they had seen a rain of fire during the night; and in the valley of the Rhone, near Culloy, three asteroids succeeded each other with such rapidity that the people, seeing them through a fog, supposed them to be flashes of lightning, or a repetition of the brilliant aurora of the 18th of October. As in the great meteoric shower of 1833, so at this time, the greater part of the falling stars which were particularly observed, seemed to issue from a point in the constellation of Leo. Of those noticed at Bercy, fifty seven traversed lines which, if continued, would have ended in that constellation; and of eighty-five observed at Strasburg, fifty-seven had similar courses. M. Arago purposes an inquiry, whether, from their number, this shower of falling stars may or may not be considered unusual; and he gives the following comparisons: At Paris, on the preceding night, none were seen, during an hour; from three to five were seen in the same space of time on the night after the shower, and from two to three on the second night. On the preceding night, at Bercy, not one was seen in two hours. At Von Altemare, on the 6th of November, none were seen during two hours' watching; on the 7th, there were four in four hours; on the 8th, none in three hours; on the 9th, one in six hours; and on the 14th, two in six hours.

I have been somewhat particular in stating the more remarkable circumstances connected with this phenomenon, as there is every reason to believe that it is produced by an unknown celestial body at a considerable distance from the earth; and I shall now proceed to give a brief view of the opinions which certain philosophers entertain, and the deductions they have been led to make in reference to this subject.

In the "American Journal of Science" for April, 1834, Dr. Olmsted, professor of mathematics and natural philosophy in Yale College, New Haven, has entered into an elaborate investigation of this subject in a communication which occupies about forty-two pages. The whole of this paper is well worthy of the attentive perusal of the philosophic inquirer, but the limits to which I am necessarily confined in this chapter will permit me to state only the *general results* of the professor's investigations; all of which appear to be deduced from the phenomena with great acuteness and ingenuity of reasoning. These results are:

1. That the meteors of November 13 had their origin beyond the limits of our atmosphere. For the source of the meteors did not partake of the earth's motion, which was demonstrable from a variety of circumstances, some of which have been alluded to above.

2. That the height of the place whence the meteors emanated, above the surface of the earth was about 2238 miles. This was ascertained from a comparison of different observations made in different places, and from trigonometrical calculations founded upon them.

3. The meteors fell toward the earth being attracted to it by the force of gravity. It seemed unnecessary to assign any other cause, since gravity is adequate to produce the effect.

4. They fell toward the earth in straight lines, and in directions which, within considerable distances, were nearly parallel with each other. The courses are inferred to have been straight lines, because no others could have appeared to spectators in

different situations to have described arcs of great circles.

5. They entered the earth's atmosphere with velocity equal to about four miles per second, or more than ten times greater than the maximum velocity of a cannon ball, and about nineteen times that of sound. This was inferred from the laws of falling bodies.

6. The meteors consisted of combustible matter and took fire and were consumed in traversing the atmosphere. They were seen glowing with intense light and heat, increasing in size and splendor as they approached the earth. They were seen extinguished in a manner in all respects resembling a combustible body like a sky-rocket; and in the case of the larger, a cloud of luminous vapor was seen as the product of combustion. That they took fire in the atmosphere is inferred from the fact that they were not luminous in their original situation in space, otherwise the body from which they emanated would have been visible.

7. Some of the larger meteors must have been bodies of great size. Some of them appeared larger than the full moon rising. Such a body seen at 110 miles distance behooved to have been one mile in diameter; at fifty-five miles, one half mile; at 22 miles, one-fifth of a mile; at  $5\frac{1}{2}$  miles, one twentieth of a mile, or 264 feet.

8. The meteors were constituted of light and transparent materials. They were of light materials, otherwise their momentum would have been sufficient to enable them to make their way through the atmosphere to the surface of the earth. They were transparent bodies, otherwise we cannot conceive how they could have existed together in their original state without being visible by reflected light.

9. The next, and one of the principal subjects of inquiry was, *What relations did the body which afforded the meteoric shower sustain to the earth?*—Was it of the nature of a satellite that revolves round the earth as its center of motion? Was it a collection of nebulous matter which the earth encountered in its annual motion? or was it a comet which chanced at this time to be pursuing its path along with the earth around their common center of motion? It could not have been a satellite, because it remained so long stationary with respect to the earth; nor was it a *nebula*, either stationary or wandering lawless through space. Such a collection of matter could not remain stationary within the solar system; and had it been in motion in any other direction than that in which the earth was moving, it would soon have been separated from the earth, since during the eight hours while the meteoric shower lasted, the earth moved in its orbit through the space of 540,000 miles. The conclusion to which Professor Olmsted arrives, after a due consideration of all the circumstances, is the following:

*That the meteors of November 13th consisted of portions of the extreme parts of a nebulous body, which revolves around the sun in an orbit interior to that of the earth, but little inclined to the plane of the ecliptic, having its aphelion near to the earth's path, and having a periodic time of 182 days nearly.*

This conclusion, the professor thinks, will account for the following, among other circumstances:—Why the phenomenon remained so long stationary with respect to the earth; why it was seen in that particular part of the heavens; and why it returns at stated periods, having appeared at Mocha, in Arabia, just one year preceding, and in a manner very similar to the present, as described by Humboldt and by Ellicot thirty-

our years before. It will likewise account for an auroral light, resembling daybreak, which was seen in the east several hours before the dawn of day, and it is also supposed it may account for the different appearances of the *zodiacal light*. The professor is of opinion that the body alluded to is somewhat analogous to that of a comet. Fig. 77 represents the supposed orbit of this body in relation to that of the earth. *E H I K* represents the orbit of the earth; *S*, the position of the sun; and *C D F G*, the supposed orbit of the body which was the source of the meteoric phenomena. At the time these phenomena were seen, the body is supposed to have been at *C* when the earth was at *E*.

Fig. 77.

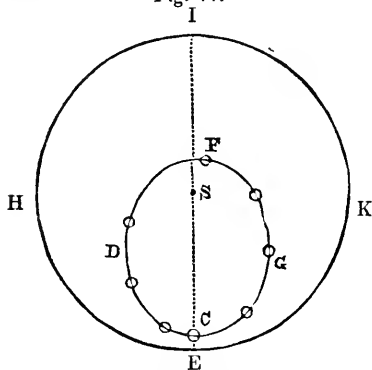

Arago appears to entertain an opinion on this subject not very different from that of Dr. Olmsted. He supposes that there may be myriads of bodies, composed probably of *nebulous* matter similar to the tails of comets, circulating round the sun in a zone or ring that crosses the earth's orbit at that part where it is about the 12th November, and that some of them, drawn from their course by the earth's attraction, fall toward it, and taking fire when they enter the atmosphere, in consequence of their prodigiously rapid motion, present the luminous phenomena of falling stars. The body or bodies from which these meteors proceed, he considers as unquestionably in rapid motion, performing a revolution round the sun in some plane different from that of the earth's orbit; and that the apparent course of the meteors will be compounded of this proper motion and of the earth's motion in its orbit at the time. It follows, that the point from which they seem to come will be that toward which the earth is moving at the time, namely, the constellation *Leo*; for the line or tangent of the earth's annual motion at the 13th and 14th November points exactly to that constellation.\*

\* A gentleman in South Carolina thus describes the effect of the phenomenon of 1833 upon his negroes: "I was

Thus it appears that celestial bodies are revolving around us of which we formerly had no knowledge or conception. A new planetary system, within the limits of the old, is beginning to be revealed to us, the number of the bodies belonging to which may be much greater than we are yet aware of, and their particular properties and motions may at no distant period be detected and explained. This is one proof, among others, that bodies of a considerable size may exist in the heavens, and be prosecuting their courses in various directions, though they have never been detected by our telescopes. The subject is peculiarly interesting to philosophers and astronomers. The facts which have already been observed afford a *sensible proof* of the attractive power of the earth over bodies at a distance in the heavens; and it is to be hoped that the future observations and investigations of scientific men, in relation to such phenomena, will throw some further light on the nature and properties of bodies which have hitherto been involved in darkness and mystery.—What the destination of such bodies may be, or the ends they serve in the economy of nature, we are as yet entirely ignorant of. It appears pretty evident that they are bodies of no great density, otherwise their effect on the earth might have been more terrific and disastrous. Had their quantity of matter been considerable, when accompanied with so prodigious a velocity as they evidently had, their momentum would have been such as to have dashed them with violence upon the earth, where the most appalling effects might have been produced, in the demolition of human habitations, and the destruction of thousands of their inhabitants. But it does not appear that any of them made their way through the atmosphere to the surface of the earth, which was doubtless owing to the comparatively light materials of which they were composed. This circumstance, along with many others, evidently shows that we may be surrounded with numerous bodies and substances impalpable to the organs of vision, any one of which might be sufficient to deprive us of our comforts, and even prove destructive to our existence, were it not under the direction and control of Infinite Wisdom and Benevolence.

suddenly awakened by the most distressing cries that ever fell on my ears. Shrieks of horror and cries of mercy I could hear from most of the negroes on three plantations, amounting in all to about six or eight hundred. While earnestly listening for the cause, I heard a faint voice near the door calling my name. I arose, and taking my sword, stood at the door. At this moment I heard the same voice still beseeching me to rise, and saying, "Oh, my God! the world is on fire!" I then opened the door, and it is difficult to say which excited me most—the awfulness of the scene, or the distressed cries of the negroes. Upward of one hundred lay prostrate on the ground; some speechless, and some uttering the bitterest cries, but most with their hands raised, imploring God to save the world and them. The scene was truly awful; for never did rain fall much thicker than the meteors fell toward the earth, east, west, north and south, it was the same!"

## CHAPTER XVI.

### ARGUMENTS ILLUSTRATIVE OF THE DOCTRINE OF A PLURALITY OF WORLDS.

HAVING in the preceding pages exhibited a condensed view of the principal facts in relation to the Sidereal Heavens, I shall now inquire into some of the designs which the Almighty Creator appears to have had in view in replenishing his universe with such an immense number and variety of magnificent orbs. In Chapter IX, of "Celestial Scenery," I entered on a consideration of this subject, and illustrated at some length a few leading arguments, which tend to prove that *matter* was created chiefly in subserviency to *mind*, and that the main object of the creation of the planets, as proved from all the decorations and special arrangements connected with them, was to afford habitations for numerous orders of sensitive and intellectual beings. Without resuming the consideration of any of the arguments there stated, I shall in this chapter offer a few additional arguments corroborative of the same position, which, taken in connection with the former, will, I trust, amount to a moral demonstration that all the great globes in the universe are in some respect or another connected with intelligent existence.

I. The first class of arguments I shall illustrate is the following:—That *the doctrine of a plurality of worlds is more worthy of the perfections of the Infinite Creator, and gives us a more glorious and magnificent idea of his character and operations than to suppose his benevolent regards confined to the globe on which we dwell.*

1. The doctrine of a plurality of worlds is more accordant with the idea of the *infinity* of the Divine Mind than any other position. It is admitted by all rational theists and theologians that the Divine nature fills the immensity of space, and we consequently adore the Creator as an infinite and incomprehensible being. But we can have no ideas approximating to what infinity really is, unless by the prospects opened to us of the indefinite extension of material existence. Beyond the limits we may assign to the material world, our ideas, if we have any ideas at all, run into confusion, and approximate to inanity. It does not comport with the idea of a Being of infinite perfection that his works should be confined to one point of infinite space, or that one comparatively small race of intelligent beings should be the sole object of the moral government of Him whose presence fills the regions of immensity. It is more corresponding to the conceptions we ought to form of such a Being that the immensity of his works should correspond, in some degree, to the immensity of his nature; and, so far as our knowledge and observation extend, this is in reality the case. Beyond the range of natural vision, the telescope enables us to descry numerous objects of amazing magnitude; and, in proportion to the excellence of the instrument and the powers applied, objects still more remote in the spaces of immensity are unfolded to our view, leaving us no room to doubt that countless globes and masses of matter lie concealed in the still remoter

regions of infinity, far beyond the utmost stretch of mortal vision. But huge masses of matter, however numerous and widely extended, if devoid of intelligent beings, could never comport with the idea of happiness being coextensive with the range of the Creator's dominions. Such an idea would completely obscure the luster of all his other attributes, and prevent them from being known and appreciated wherever his Omnipotence is displayed. To consider creation, therefore, in all its departments, as extending throughout regions of space illimitable to mortal view, and filled with intelligent existence, is nothing more than what comports with the idea of Him who inhabiteth immensity, and whose perfections are boundless and past finding out.

2. The idea of the indefinite extension of the universe and a plurality of worlds is most accordant with the *eternity* of the Divine Mind. When we go back in imagination to ages and centuries of duration more numerous than the drops of ocean or the sands on the sea-shore, we find the Deity existing in all the plenitude of his incommunicable attributes; for "He inhabiteth eternity," as well as immensity. There is nothing repugnant either to reason or revelation to suppose that, innumerable ages before our globe was arranged into its present state, many regions of infinite space were replenished with material existence; for the Scriptures nowhere assert that the *materials* out of which our globe was arranged were brought from nothing into existence *at the period* when Moses commences his narrative of the processes which preceded the formation of man. Nor have we any reason to believe that the operations of Creating Power have ceased since the structure of our world was completed, but have some evidences of the contrary; for example, in the case of *new stars* which have made their appearance at different periods since the time of the Mosaic creation, and even within the limits of the last century. It does not appear corresponding to the idea of an *Eternal Being*, whose existence can never terminate, and whose perfections are the same at all periods of duration, that everything should stand still in the universe, and that nothing new should arise into existence during the lapse of infinite duration, which would in effect be the case if the work of creation were absolutely finished, or if *man* were the principal intelligence connected with the material system. Whether the happiness of the Divinity may be increased by the contemplation of his purposes and plans being brought into effect, we cannot positively declare; though it does not appear contrary to reason or the Dictates of Scripture to suppose that even the felicity of the Deity may, in a certain limited and modified sense, be susceptible of augmentation.\* But whatever opinion

\* It is declared in Psalm cxlviii, 11: "The Lord taketh pleasure in them that fear him, in those that hope in his mercy;" and in relation to Messiah it is said, "Jehovah is

may be formed on this point, from the constitution of *finite* minds, and the principles and desires implanted in them, it appears necessary to *their* progressive enjoyment that new scenes and manifestations of Divine perfection should be continually opening to their view; and if the universe be indefinitely extended, as it appears to be, and if new worlds are continually springing up under the creating hand of the Omnipotent, then we behold a prospect of progressive knowledge and enjoyment suited to the desires and aspirations of intelligent minds, which can never terminate throughout all the future periods of eternity. It is indeed *absurd* to suppose that a Being without beginning and without end should have his attention solely or chiefly directed to one point of his universe, and to one class of intelligences, "to whom," in point of number and of rank, "they are counted as nothing and less than nothing, and vanity."

In respect to a Being, then, who fills the infinity of space with his presence, and who is possessed of eternal duration, it is nothing more than what is consistent with these attributes, and what we should naturally expect, that his empire should stretch over the regions of immensity, and that it should be filled with innumerable intelligences, capable of appreciating his power and goodness, and of paying a tribute of gratitude and adoration. The two attributes to which we have adverted could never be thoroughly displayed to finite minds, unless creation were extended through the illimitable tracks of space, and new creations gradually unfolding themselves to view. Were creation as limited as many suppose, were it confined chiefly to the world in which we dwell, and the beings connected with it, we might in the course of a few ages be said in some measure to comprehend the Creator, having explored all the displays he has made of his power, wisdom, and goodness; for we know nothing more of the Deity than the *manifestations* he has made of himself in his works and his moral dispensations. Everything in relation to man and his habitation might be known after the investigations of a very limited number of ages, and nothing further would remain to stimulate the exercise of the rational faculties throughout all the succeeding periods of infinite duration. But we may rest assured that the Divine Being is absolutely incomprehensible, and that no created intelligence will ever be able to sound the depth of his perfections, or to trace the full extent of his operations.

3. It is more accordant with the *wisdom* of the Deity that the universe should be inhabited by rational minds, than that it should remain in a state of perpetual desolation and solitude.

Could it be proved that the planets of the solar system, and all the other magnificent globes which are dispersed throughout creation, are only rude masses of matter, without life and intelligence, it would confound all our ideas of the intelligence of the Divine mind. Wisdom is universally

acknowledged to be one of the eternal and essential attributes of the Divinity. But how could the glory of this attribute be traced from the contemplation of a mass of more inanimate matter, however vast and splendid in its general aspect, when no end or design of its creation is perceived? Where should we be enabled to perceive the nice adaptation of means to ends? the harmonious operation of principles and causes producing grand and beneficent effects? the accomplishment of glorious and useful designs by admirable arrangements? We could only behold a vast and stupendous assemblage of means *without an end*; or, at least, without an end corresponding to their magnitude and grandeur. We should behold merely a display of boundless and uncontrollable power acting at random, and producing no effect which could excite the love and admiration of holy intelligences. For what could they behold to excite such emotions, although they were permitted to make the tour of the universe? Scenes of emptiness and desolation, of silence and solitude, where no sound is heard, where no animated being enlivens the boundless prospect, where no interchange of sentiment or affection can take place, and where no praises from adoring worshippers ever ascend to the Ruler of the skies. A rational being traversing scenes of this description would feel as little enjoyment as a bewildered traveler, amid storms and tempests, wandering over a vast howling wilderness, where human feet had never trod, and where the sweet accents of the human voice are never heard to cheer the surrounding solitude.

But when we view the magnificent globes which are scattered throughout immensity as replenished with numerous orders of intelligent beings, we behold an *end* worthy of the grandeur of the means which have been employed, worthy of the omnipotent power which has been exerted, and corresponding to the perfections of him who is "the only wise God," who is "wonderful in counsel, and excellent in working." We behold a display of Divine wisdom and munificence which is calculated to arrest the attention and draw forth the admiration of all rational beings, and to excite the most ardent desires of beholding the distant scenes of the universe more completely unfolded—a display calculated to gratify intelligences of the highest order, and of the most capacious powers, to excite them to the most sublime investigations, and to inspire them with emotions of love, reverence, and adoration of Him who created all worlds, and for whose pleasure they are and were created.

4. The idea of the universe being replenished with sensitive and intellectual existence is accordant with every rational view we can take of the *goodness* or *benevolence* of the Deity.

The goodness of God is that attribute of his nature by which he delights to communicate happiness to all the ranks of his sentient and intelligent offspring. Like every other attribute of the Divine mind, it is strictly boundless or infinite, coextensive with the eternal greatness of that mind, and commensurate with infinite knowledge, wisdom, and omnipotence. The benevolence of the Deity may be said to constitute his whole moral character, and to reflect a radiance on all his other perfections. To his *love* of happiness, as it now exists among every order of his creatures, and to his *desire* of producing it in all his future arrangements, no possible limits can be affixed. Hence, in the sacred records, the Divine Being is summarily described by this perfection alone, "*God is love.*" It is not merely asserted

well pleased for his righteousness's sake." In reference to the material works of creation it is said, Psalm civ, 31, "The glory of the Lord shall endure forever; the Lord shall rejoice in all his works." The expression, "The glory of the Lord," denotes the display of the Divine perfections made in the works of creation, as is evident from the subject of the psalm in which it occurs, which celebrates the power, wisdom, and providence of God, in relation to the objects of the visible world. In reference to these objects it is said, "The Lord shall rejoice" in them, which seems to imply, speaking after the manner of men, a degree of pleasure or satisfaction in beholding his wise and benevolent plans, and his eternal purposes, brought into effect and fulfilling the ends intended.

that God is benevolent, but that he is *benevolence* itself. Benevolence is the essence of his being and character—a summary of everything that can render him amiable and adorable in the eyes of all his intelligent creatures. This benevolence is permanent and immutable, and must be *forever active* in distributing blessings wherever percipient beings exist. As it consists in the love of happiness, and the desire of communicating it wherever there is scope for its exercise; as it is the boundless energy of the infinite Mind in unceasingly doing good, it must be displayed, in a greater or less degree, wherever matter exists, and wherever wisdom and omnipotence have been exerted throughout the universe. We know that it is incessantly displayed throughout all the departments of our terrestrial system, in the ample provision made for the wants of every species of animated existence, in “giving” the various tribes of men “rain from heaven and fruitful seasons, and filling their hearts with food and gladness;” and, in a wonderful diversity of modes, distributing enjoyment among percipient beings. It is celebrated in the highest strains by the inspired writers as one of the most glorious and distinguishing characteristics of Jehovah. “The Lord is good to all; his tender mercies are *over all* his works.” “He is merciful, and gracious, and *abundant* in goodness.” “His bounty is great above the heavens,” and “he exercises loving kindness throughout the earth.” “O give thanks to the Lord, for he is good, for his mercy endureth forever.”

But however great and inexhaustible the source of happiness in the Divine mind, the *exercise* of goodness necessarily supposes the existence of sensitive or rational beings, toward whom benevolence may be displayed. Where no such beings are to be found, this attribute cannot be exercised or traced in its operation. Mountains and plains, rocks of marble and diamonds, or valleys adorned with all manner of precious stones, however rich and splendid, cannot feel the effects of Divine beneficence. If, therefore, the numerous globes throughout the universe were destitute of inhabitants, there would be no extensive display of this essential perfection of the Divine nature; and to those few intelligences who might be permitted to view the desolate wastes of the universe, or to receive information respecting them, it would appear as if the Divine goodness had either been exhausted or had ceased its operations, and been withdrawn from the scene of creation, as if “the Lord had forgotten to be gracious, and in anger shut up his tender mercies.” We have reason, however, to believe, both from scripture and from reason, that it is the great end of all the operations of Deity that a theater may be prepared, on which the emanations of his goodness may be communicated to innumerable orders of beings throughout his vast creation. There is no other conceivable end for which the fabric of universal nature was reared than that it should serve as a scene of enjoyment to innumerable beings susceptible of feeling the effects of the Creator’s bounty, and that therein they might behold a magnificent display of the grandeur of his eternal attributes; but if by far the greater part of creation were uninhabited, such an end would be frustrated. However expansive the scene of the universe may be—however numerous and magnificent the worlds and systems which exist within its boundless range, the glories of Omnipotence would remain forever veiled and unknown, except to a small race of beings who occupy only a point in the immensity of space, and who cannot possibly be acquainted

with the ten-thousandth part of the scenes which lie in the remoter spaces of creation.

If, therefore, we would not rob the Divinity of the most distinguishing attribute of his nature, we must admit that wherever creation extends, his goodness and beneficence are displayed, and, consequently, that intelligent beings of various orders must exist throughout all its amplitudes. Wherever power and wisdom are displayed, it ought to be considered as a necessary consequence that there also goodness is exercised, as the one is subsidiary to the other, and stands related as means to an end, or as cause to effect. It would be a most glaring piece of inconsistency to suppose that the Divine benevolence is confined to one or two worlds or orders of beings, when millions of expansive systems diversify the fields of immensity; more especially when we consider that the goodness of the Deity is of so *communicative* a nature that all the interval between a polypus and a man is filled with thousands of species of animated beings, of every conceivable form, and structure, and capacity, in order that happiness of every degree may be diffused among every possible order of sentient existence. Every element of nature, every department of our terrestrial system, forms an appropriate abode for living beings. The air, the waters, and the earth teem with animated existence of every size and form, and in such vast multitudes as to exceed all human calculation; and if the displays of Divine goodness be thus exuberant in our subinary world, it would be absurd in the highest degree to suppose for a moment that the millions of vast globes, which roll in the distant regions of creation are devoid of inhabitants, since the communication of happiness appears to be one great end of all the operations of infinite wisdom and omnipotence.

Thus it appears that the doctrine of a plurality of worlds is not only accordant with every rational view we ought to entertain of the eternity and immensity, the wisdom and goodness, of the Divine Being, but that the opposite opinion would be repugnant to every consistent and scriptural view we can take of the character of the Supreme, and would obscure the glory of every divine perfection. This view, therefore, of the universe, considered as replenished with innumerable intelligences, is calculated to exhibit a more glorious and magnificent idea of the character and operations of the Deity than to suppose his benevolent regards confined to the globe on which we dwell. Instead of having only one comparatively small world and race of beings under his sway, we here contemplate him as the supreme ruler of ten thousand times ten thousands of mighty worlds, and conducting them all, with unerring skill, in their vast career. We behold him exercising his moral administration over a vast universe of minds, more numerous than the faculties of men or of angelic beings are adequate to compute, supporting and directing all the amazing powers of thought, wisdom, intelligence, affection, and moral action throughout every part of his eternal empire, displaying the depths of his wisdom and intelligence, the rectitude of his character, and the grandeur of his omnipotence to countless orders of intellectual existence, presenting before them prospects of magnificence and grandeur boundless as immensity, distributing among them all the riches of his beneficence, and inspiring them with the hope that the grandeur of his kingdom and the glory of his perfections will continue to be displayed with increasing splendor throughout all the periods of an endless duration. Such a Being is calculated to



draw forth the highest degree of love and admiration from all his intelligent offspring, to inspire them with glowing ardor in his service, and to excite them to incessant adoration; whereas, did the universe consist merely of a boundless mass of matter without animation, thought, or intelligence, a veil of darkness and mystery would be thrown over all the perfections and purposes of the Divinity; creation would appear a vast, mysterious, and inexplicable system; and no hope would ever be entertained of tracing the designs for which it was brought into existence.

II. Another general argument for the plurality of worlds, and for an extensive population of the universe, may be founded on the following proposition:—*that wherever any one perfection of Deity is exerted, there also ALL his attributes are in operation, and must be displayed, in a greater or less degree, to certain orders of intelligences.* This is a most important consideration, which ought to be taken into account in all our views of the Divine character, and in all our investigations of the Divine administration—a consideration which is too frequently overlooked in the views and reasonings both of philosophers and theologians.

The Divine Being is ONE undivided essence; he is NOT compounded of *separable* parts or qualities, insulated from each other. We ought not, therefore, to conceive of his attributes as so many independent powers or properties, any one of which may be exerted without the concurrence or co-operation of the other. From the limited views we too frequently take of the Divinity, and from the imperfection of our present faculties, we are apt to fall into this mistake; but since all the perfections we attribute to the Eternal Mind are attributes of one indivisible and uncompounded Being, we ought never to imagine that *power* in any instance operates without *goodness, or wisdom* without *rectitude*, or that it can ever happen that any one of those perfections can be displayed without the harmonious operation of the whole. In whatever regions of the universe, therefore, God is seen to operate by his power, we may rest assured that there also he displays himself in the plenitude of all his other perfections; that intelligence, wisdom, benevolence, veracity, and rectitude follow in the train of omnipotence, displaying in undivided luster and harmony the glories of his character. It is God, invested with all his eternal and immutable, his natural and moral attributes, and not any single perfection, that acts, arranges, and governs throughout the whole amplitude of creation; and as such, his moral grandeur, as well as the physical effect of his power, must be displayed in every department of the material universe. From the influence of habit, and in consequence of the limited faculties of our nature, we are accustomed to say, that in one object *power* is displayed, and in another that *wisdom* is manifested; because, that in the one the attribute of power appears to us most prominent, and in the other, wisdom is more strikingly apparent. A lofty range of mountains, rearing their summits above the clouds, and stretching along for several hundreds of miles, strikes the mind with an idea of *power* in Him who formed them; but the fine mechanism, accomplishing certain useful purposes in the body of an emmet or a gnat, or the delicate construction of the eye of a dragon-fly, arrests our attention more particularly as an evidence of *wisdom*, although in each of these cases both power and wisdom are displayed. In no act or operation whatever of the Divine Being can it be said, that in that act he is *only* wise, or *only* powerful, or *only* benevolent; for in every operation, and in

every part of his procedure, he acts in the *plenitude* of all his essential attributes, although the full display of all his perfections may not, in every instance, be open to our inspection.

If, then, the positions now stated be admitted (and I see not how they can be called in question), it necessarily follows that all the vast globes dispersed throughout the universe are either inhabited or contribute, as our sun does, to the comfort and enjoyment of percipient existence; for if wisdom and goodness uniformly and of necessity accompany the agency of power, and if these attributes can be exercised only in relation to sentient or intelligent beings, such beings must exist wherever such perfections are exercised. To suppose the contrary would involve a palpable absurdity, and present a distorted and inconsistent view of the adorable character of Jehovah.

In our survey of the sidereal heavens, and the remoter provinces of the Divine empire, we behold little more than an overwhelming display of almighty power. Our remoteness from those magnificent scenes prevents us from tracing the minute contrivances of Divine Wisdom in relation to any particular system, or the displays of Divine Benevolence toward its inhabitants. But our incapacity in perceiving the effects of wisdom and goodness forms no arguments against the actual exercise of these perfections. If it be admitted that infinite wisdom and benevolence are the necessary accompaniments of almighty power, we may rest assured that those perfections are in full and constant exercise wherever creating power has been exerted, although, from our present situation in the universe, their operation be concealed from our view. In every instance where Omnipotence has put forth its energies, it may be considered as a stage or theater on which the Divine wisdom and benevolence may be displayed. And as wisdom and goodness can only have a reference to percipient and intelligent beings, wherever those perfections are exercised, such beings must necessarily be conceived to exist; otherwise, we in effect destroy the *simplicity* of the Divine nature, we divide the Divine essence into so many independent attributes, and virtually declare that in the work of creation the Deity does *not* act in the full exercise of his indivisible and eternal perfections.

The above considerations, if duly weighed and understood, appear to me to embody an argument for the doctrine of an indefinite plurality of worlds, which may be considered as amounting to a moral demonstration.

III. There is an *absurdity involved in the contrary supposition*—namely, that the distant regions of creation are devoid of inhabitants.

I. There are two modes of reasoning which have been employed to prove the truth of a proposition: the *direct* method, by bringing forward arguments, or following out a train of reasoning bearing expressly on the position to be supported; or the *indirect* method, by showing the absurdity of maintaining the opposite position. Mathematicians term this latter species of reasoning the *reductio ad absurdum*, and sometimes employ it instead of the direct method, by showing that the contrary of the position laid down is impossible, or involves an absurdity; and this method of proof is considered as valid, and as strictly demonstrative as the other; for the opposite of truth must be falsehood. If, therefore, any proposition, whether mathematical or moral, can be shown to involve an absurdity, or to be inconsistent with a well-known and acknowledged truth, or directly contrary to it, we may safely conclude that such a proposition must be *false*.

To feel the force of such an argument in the present case, let us suppose for a moment that the planetary and stellar orbs are destitute of inhabitants. What would be the consequences? All those vast bodies must then be considered as regions of eternal silence, solitude, and desolation. The sun illuminates the surfaces of such huge globes as Jupiter and Saturn, but there are no visual organs to perceive the luster he throws around, no percipient beings to feel the influence of his heat and other benign agencies. Time is measured, with exquisite precision by days, and months, and years, but all to no purpose; for no rational beings enjoy the advantage of such measures of the lapse of time, and the Deity—to whom “one day is as a thousand years, and a thousand years as one day”—stands in no need of such movements to mark the periods of duration. Day and night, spring and summer, succeed each other, but they have no relation to the wants or enjoyments of sensitive or intellectual natures. The melody of the groves, the bleating of flocks, the lowing of herds, the harmonious accents of human voices, or the music of angelic choirs, never for a moment disturb the profound and awful silence which forever prevails; not a single murmur meets the ear, unless howling winds, amidst dreary deserts and rugged rocks, should render the scene still more hideous and doleful. Some of those mighty globes are encircled with splendid rings and a retinue of moons, which adorn the canopy of the sky, and present a scene of grandeur far more diversified and sublime than human eyes have yet beheld, but no intelligent agents exist in those regions to admire and enjoy the wondrous spectacle and to adore the great Creator. In short, all is one wide scene of dreariness, desolation, horror, and silence, which would fill a spectator from this world with terror and dismay.

Were an inhabitant of the earth to be transported to Jupiter or Saturn, he might behold resplendent scenes in the canopy of the firmament; but how great would be his disappointment to find nothing but boundless deserts and desolate wastes, without one sentient being to cheer the horrors of the scene, and not a rational intelligence to communicate a single sentiment or to join him in the contemplation of the objects above and around him; and were he to range throughout an indefinite lapse of ages from one globe to another, and from one corner of the universe to another, and find the same gloomy solitudes and desolations, he could find no stimulus to excite him to admiration or rapture, or to elevate his soul in adoration of the Creator. Even the most resplendent scenes, adorned with all the riches and beauties which the most lively imagination can depict,—mountains of diamonds and plains diversified with all the beauties of the vegetable creation,—could impart no real pleasure while unenlivened with the principle of animation and the energies of mind. What a gloomy and horrible picture would such a scene present of the frame of universal nature, and what a veil of darkness and mystery would it throw over the perfections of the Eternal! for it is the scenes connected with life, animation, mental activity, and moral sentiment, glowing affection, social intercourse, and the mutual sympathies of intellectual beings, that can alone inspire the soul with rapturous emotions, throw a charm over any part of creation, and exhibit the Almighty Creator as amiable and adorable. It is chiefly from the relation in which the material world stands to sensitive and intellectual existence that its beauty and order are

recognized and admired by contemplative minds, and that the wisdom and beneficence of the Deity are traced in all their minute and multifarious bearings. In our world, as it now stands, the arrangement of mountains and vales, the various properties of the watery element, and its transmutation into vapors, clouds, and dew, the admirable mechanism of the atmosphere, the fertility of the earth, and the beautiful coloring which is spread over the face of nature,—which are productive of so many beneficial effects, and so evidently display the wisdom of Deity,—would all appear as so many means without an end, as contrivances *without use*, if the earth were destitute of inhabitants. And if all the other departments of creation were likewise devoid of animation and intelligence, scarcely a trace would be left throughout boundless space of the wisdom and benevolence of the Eternal Mind.

2. In the next place, such a position as that which I am now opposing would be inconsistent with that principle of *variety* which appears so conspicuous throughout the whole range of the Divine operations, and with that *progressive expansion of intellectual views* which appears necessary to the perpetual enjoyment of immortal beings.

In order to permanent enjoyment it is necessary, from the very constitution of the mind, that one scene of happiness should succeed another,—that the soul should look forward to the future, to something *new* or more grand and expansive than it has yet beheld or enjoyed. It can never rest in present objects and attainments, but is always on the wing for something higher and more exquisite than it has yet grasped or enjoyed. What is the reason, in most cases, why *imprisonment* produces so doleful an effect upon the mind, but because its views and its actions are confined to a narrow circle? And if in such a situation newspapers, books, paper, pens and ink, be withheld, so as still further to circumscribe the mental view, its want of enjoyment and its misery are still more increased. Why would a literary man feel unhappiness had he no access to books, journals, and the periodicals of the day, nor any other means of information respecting passing events, but because he would thus be confined to his present range of view, and prevented from enlarging it? And why should the man who devours the periodical journal to-day feel as craving desires to-morrow to peruse similar records of intelligence, to mark the progress of passing events, but from the same vehement desire to expand his present intellectual views? Were such desires to remain ungratified, and the prospect of further information entirely shut up, a certain degree of misery would necessarily be felt by every rational mind. In another world, something similar would happen in the case of all intellectual beings, were no new scenes and prospects ever unfolded to view.

Divines have generally admitted that the eternal world, in the case of the righteous, will be a state of perpetual and uninterrupted enjoyment. Such enjoyment, however, could never be realized, unless new scenes and objects, worthy of the admiration of exalted intelligences, were progressively displayed. But the contemplation of rude masses of matter, however vast in point of size and extent, and however magnificent in point of splendor, were they entirely unconnected with mind and moral action, would produce no high degree of enjoyment to beings possessed of capacious powers of intellect; for in such objects they could trace no evidences of skill or design, nor would they perceive any overflowings of Divine goodness to inspire them with gratitude and

praise. We are warranted from Revelation to expect that in the future world the *knowledge* of good men will be indefinitely increased, in respect to their more enlarged conceptions of the Divine Being, and of his works and ways; that, among other subjects, they shall become more acquainted with the distant regions of creation, the destination of those great globes which we now behold at an impassable distance, the history of their inhabitants, the various stages of improvement through which they have passed, the most remarkable events which have happened among them since their creation, the relations which the different worlds bear to each other, the various orders of intellectual beings and their distinctive characteristics and endowments, with many other particulars which would afford an ample field of investigation and contemplation which could scarcely ever be exhausted, and a source of progressive and permanent delight. But all such prospects of knowledge and enjoyment would be forever shut out, were the universe a collection of mere matter unconnected with mind or intelligence, and the distant view of an immortal existence would present little else than a scene of monotony or a boundless blank.

In the future world, although the circumstances in which the mind will exist, will be different from its present local associations, yet its faculties, desires, and affections, will not be *essentially* changed. It will continue the same identical being, only transported to another region, and connected with other objects and associations.—It will have the same or similar aspirations after happiness, the same desires after new objects and discoveries, and the expansion of its intellectual views, and the same delight in beholding one scene of creating grandeur after another unfolding itself to view, as it feels, in a certain degree, in the present state. Such desires after progressive improvement in knowledge and happiness are implanted by the Creator, and form an essential part of the constitution of the human soul, and therefore can never be eradicated so long as it is sustained in existence. But it is evident, from what has been already stated, that such desires could never be gratified, and that its expectations of higher degrees of intellectual expansion and enjoyment would be frustrated, were the scene of Omnipotence nothing more than an indefinite extension of matter without life or intelligence; for in such a case there would be little scope for the exercise and expansion of its powers throughout an immortal existence.

3. The supposition that matter throughout the universe is not connected with mind would present a distorted view of the character of the Almighty, and throw a veil over the most glorious perfections of his nature. It would virtually deprive the Creator of the attribute of *wisdom*; since no display of it would be perceived in the most magnificent works of his hands. It would, in effect, rob him of his *goodness*; since, throughout the mightiest and most extensive portion of his works, no enjoyment is communicated to beings endowed with either sensitive or rational natures, which are alone capable of being recipients of his bounty; consequently, no tribute of gratitude and thanksgiving would be offered, and no praises or adorations would ascend to the throne of the "King eternal, immortal, and invisible," from the greatest portion of his boundless dominions. It would prevent us from beholding any extensive display of the *rectitude* of his character and the equity of his government in the moral administration of the universe. Now,

wisdom, goodness, and rectitude, can only be exercised in reference to intelligent natures, and cannot possibly be displayed where such beings have no existence.

The denial therefore of the position, that the great universe is peopled with inhabitants, would lead us to contemplate a Being whose power has brought into existence a magnificent assemblage of means without an end; who has prepared glorious habitations fitted for the enjoyment of rational natures, but has never peopled them; who is the alone source of happiness, and yet refuses to communicate of his goodness where there is full scope for its exercise; and who is the Supreme Lawgiver and the spring of moral order, and yet affords no display of his moral attributes throughout the immensity of his works: for this earth, and all the beings that have ever been connected with it, are but as a drop to the ocean compared with the immensity of the material universe. Can it therefore be a theater of sufficient expansion for the display of the character and attributes of that being who has existed from eternity past, and will exist to eternity to come, and whose presence fills the amplitudes of boundless space?

If, then, such absurd consequences necessarily follow from maintaining the position, that there is no plurality of worlds, *that position cannot possibly be true*. It undermines truths of the first importance, which lie at the foundation of all consistent views of the character of the Deity, and which are acknowledged to be such by all rational theists and Christian divines. And, since what is directly opposed to truth must be error, and *vice versa*, it follows that the doctrine we are supporting must be considered as susceptible of moral demonstration; for it may be laid down as an axiom, that it is essential to the character of Deity that he act consistently in all parts of his dominions, that he display in every instance *all his perfections* in harmony, and that wherever his omnipotence has been exerted, there likewise he must display his wisdom, benevolence, and rectitude.—Whatever opinion therefore directly tends to undermine or oppose such views of the Divine character and perfections must be absolutely untenable, and the opposite opinion must be indisputably true.

In my work on "Celestial Scenery" I entered on the consideration of several arguments which tend to prove the doctrine of a plurality of worlds, and that the planets of the solar system in particular are the abodes of intellectual beings. This position was illustrated at some length from the following considerations: that there are bodies in the planetary system of such *magnitudes* as to afford ample scope for myriads of inhabitants; that there is a *general similarity* among all the bodies of the system, which affords a presumptive evidence that they are intended to subserve the same ultimate designs; that, connected with the planets, there are certain *special arrangements* which indicate their adaptation to the enjoyment of sensitive and intellectual beings; that the scenery of the heavens, as viewed from the surfaces of the larger planets and their satellites, furnishes a presumptive proof of the same position; and that the fact that *every part of nature in our world is destined to the support of animated beings*, affords a powerful argument in support of this doctrine. These arguments and considerations, when viewed in all their bearings, and in connection with the wisdom and goodness of the Divine Being, might be considered, without any further discussions, as quite sufficient to substantiate the position, that the planets and satellites of our system, are

well as other departments of the universe, are the abodes of sensitive and intelligent beings.

In the preceding pages I have offered a few additional considerations bearing on the same point, which, I trust, will tend to corroborate the arguments and reasoning formerly adduced.—I have shown that the doctrine of a plurality of worlds is more worthy of the perfections of the finite Creator, and gives us a more magnificent idea of his character and works, than to suppose his benevolent regards confined to our comparatively diminutive world; that it is more accordant with the *infinity* and *eternity* of the Divine Being, and with his *wisdom* and *benevolence* than the opposite position; that wherever any one perfection of Deity is exerted, there also *all* his attributes are in operation; and consequently, wherever Omnipotence is seen to operate, there likewise, wisdom, benevolence, rectitude, and every other Divine perfection, must be displayed, and can only be displayed in reference to intelligent beings; that

there is *an absurdity involved* in the contrary supposition; that this supposition would represent the universe as an immense desert, unworthy of the contemplation of intelligent minds; that it would prevent the progressive expansion of intellectual views in a future state, and present a distorted view of the character and attributes of the Almighty Creator. All these arguments and considerations, when viewed in a proper light, tend to yield a mutual support to each other, they hang together in perfect harmony, and they are in full consistency with the most amiable and sublime conceptions we can form of the Divinity; and therefore ought to carry irresistible conviction to the mind of every unbiased and intelligent inquirer. To my own mind, they amount to a *moral demonstration*; so that I am as fully convinced of the truth of the position we have been maintaining, as if I were transported to the regions of distant worlds, and permitted to mingle in association with their inhabitants

## CHAPTER XVII.

### A PLURALITY OF WORLDS PROVED FROM DIVINE REVELATION.

It is somewhat difficult to persuade the greater part of mankind that there are any habitable worlds beside our own, or that rational beings, somewhat analogous to man, may inhabit the planets of our own or of other systems. Even the greater part of Christians, and some who are possessed of a considerable degree of intelligence, can scarcely be persuaded that there are more worlds than one, or that the Divine government extends beyond the Christian Church and the nations of the earth; and they attempt to vindicate their opinion by asserting that the Scriptures never make the least allusion to any world except that in which we dwell. Although this were in reality the case, it would form no argument against the doctrine of a plurality of worlds: for the revelations contained in the Scriptures are chiefly of a *moral* nature, their great object being to counteract the depravity of man, and to afford information respecting the plans, and perfections, and moral government of the Divine Being, which the unassisted light of nature was unable to explore. They were not intended to teach us the principles of physical science, or the particular knowledge of any other subject which the human faculties were of themselves adequate to acquire; but to direct us, in all our surveys of the works of God, to look upward to him as the Supreme Agent, to trace his attributes in all his operations, and to offer him a tribute of grateful adoration.—The Scriptures, therefore, would be fully sufficient to answer all the purposes of a revelation to man, although they made no allusion to other worlds, or to other intelligences within the range of the Divine government.

Since the system of nature, the system of revelation, and the rational faculties of man, had their origin from the same Almighty Being, we should naturally expect that they should perfectly harmonize in their grand lineaments, and in the truths they are calculated respectively to unfold; or, at least, that there should be no glaring con-

tradiction between the intimations given by the one and by the other. If the investigations of reason in regard to the material universe necessarily lead to the conclusion that numerous worlds exist throughout immensity, and if the Scriptures contain a communication from God, we should never expect to find in that revelation any proposition asserting that there is only one world and one race of intelligent beings in the universe, and it is needless to say that no such proposition is to be found in the Bible. On the contrary, though the Scriptures never directly or explicitly treat of this subject, the doctrine of a plurality of worlds is embodied in many passages of the sacred writings; and the language of the inspired penman is in all cases perfectly consistent with the idea of myriads of worlds existing throughout the universe. To illustrate this position, in a few instances, is the object of this chapter; and as the passages of Scripture in which this sentiment is embodied are more numerous than is generally apprehended, I shall select only a few of them as the subject of comment and illustration.

The first passage on which I shall offer a few remarks is Psalm viii, 3, 4: "When I consider thy heavens, the work of thy fingers, the moon and the stars, which thou hast ordained; what is man, that thou art mindful of him! or the son of man, that thou visitest him!"

When composing this hymn of praise to God, the Psalmist evidently appears to have been contemplating, with intelligence and pious emotion, the glories of the nocturnal sky—the moon walking in brightness along the canopy of heaven, and the stars and planets diffusing their luster from more distant regions. Viewing those resplendent orbs, his thoughts seem to have taken a flight into the regions of immensity, and by the guidance of his rational powers, and aided by the spirit of inspiration, he takes an expansive view of the multitude, the magnitude, and the grandeur of those magnificent orbs which roll in the distant

tracks of creation. Overwhelmed with his views of the immensity of the universe, and of the perfections and grandeur of its Creator, he breaks out into this striking exclamation, "Lord! what is man, that thou art mindful of him! or the son of man, that thou visitest him!" Surveying with his intellectual eye the boundless extent of God's universal empire, he shrinks, as it were, into nothing, and seems almost afraid lest he should be forgotten or overlooked amid the immensity of beings over which the Divine government extends. Now, there could be no emphasis or propriety in this exclamation, if the inhabitants of this globe were the only rational beings that peopled the material universe; for, if man is the principal inhabitant of creation, it could be no matter of wonder and astonishment that God should be "mindful of him," and exercise toward him a special regard and superintending care. Such a minute attention and affectionate regard is nothing more than what we should have naturally expected. But, if the immensity of space be diversified with ten thousand times ten thousand worlds, replenished with rational inhabitants, as science and right reason demonstrate; if the race of Adam appear no more in proportion to the beings that peopled the amplitudes of creation, than as a drop to the ocean, then the Divine condescension appears truly wonderful and astonishing,—that, from the heights of his glory in the heavens, the Most High should look down with an eye of complacency on the puny inhabitants of earth, and regard them with a Father's attention and care. This is evidently the leading idea which the pious exclamation of the Psalmist is intended to convey; and therefore, if this globe were the only or the principal abode of rational beings, such language would be mere hyperbole, or something approaching to bombast, which would be inconsistent with the veracity and solemnity of an inspired writer.

It appears, then, that the passage under consideration is not only consistent with the doctrine of a plurality of worlds, but necessarily embodies in it the idea of the Divine empire being indefinitely extended, and comprising within its range numerous orders of exalted intelligences. It likewise teaches us, that while the Almighty has diversified the fields of immensity with innumerable worlds; that while he sits enthroned on the magnificence of his works in the distant regions of his creation, and governs the affairs of unnumbered orders of intellectual existence, *he also exercises the minutest superintendence over every world he has created*, however diminutive in comparison of the whole. His eye rests on the humblest and the minutest of its objects, and his Spirit watches over it as vigilantly as if it formed the sole object of his physical and moral administration; so that neither man nor the smallest microscopic animalculæ are overlooked amid the multifarious objects of the Divine government. This is an attribute peculiar to the Most High, which flows from the immensity of his nature and the boundless knowledge he has of all his works, and which gives us a more glorious and sublime idea of his character than if his regards were confined to one department of his empire, or to one order of his creatures; and in nothing is the Divine Being so immensely separated from man, or from any other rank of intelligent existence, as in the display he gives of this wonderful and incommunicable attribute. By overlooking this peculiar characteristic of the Divinity, and attempting to compare his procedure with the limited conceptions of our own minds, we are

apt to indulge in very contracted and erroneous views respecting his nature and universal government, as well as in regard to the revelations of his word and the dispensations of his providence.

The next passage I shall notice is Isaiah xl, 15, 17. "Behold, the nations are as a drop of a bucket, and are counted as the small dust of the balance." "All nations before Him are as nothing, and they are counted to him less than nothing and vanity."

In the chapter from which these words are taken, the prophet announces deliverance from the captivity of Babylon, and the approach of that period when "the glory of Jehovah shall be revealed, and when all flesh shall see it together."—In order to obviate every difficulty that might seem to stand in the way of the accomplishment of such a glorious event, the prophet describes, in the most sublime language, the perfections and character of him by whose agency this astonishing change in the world was to be introduced. He is declared to be that Almighty Being "who measures the ocean in the hollow of his hand, who meteth out the heavens with the span, who comprehendeth the dust of the earth in a measure, and weigheth the mountains in scales, and the hills in a balance." The prophet likewise denounces the folly and wickedness of idolatry, by exhibiting the character and operations of him whom no material images, however splendid, can ever represent or adumbrate. "He sitteth on the circle of the sky which surrounds the earth, and the inhabitants thereof are as grasshoppers; he stretcheth out the heavens as a curtain; he bringeth forth their host by number; he calleth them all by their names, by the greatness of his might; for that he is strong in power, and there is no searching of his understanding." Among these sublime descriptions are contained the passages I have quoted,—"Behold, the nations are as the drop of a bucket." "All nations before him are as nothing," &c. Such declarations could scarcely be made with propriety, if all the rolling orbs of heaven were destitute of inhabitants; for then it would not be true that "all nations are as the small dust of the balance," and that they are "counted to Jehovah as less than nothing and vanity." They who deny the doctrine of a plurality of worlds assume the position, "that man holds the principal station in the material universe;" but were this the case, then the nations of the earth, and "their multitude and glory," behooved to be considered as the greater portion, or as one of the greater departments of the Divine empire; and if so, it would be approaching to extravagance and bombast for any one to declare that they are only like a drop compared with the ocean, like a few particles of dust compared with a mighty island, or, in comparison with other departments, that "they are as nothing, and less than nothing and vanity."

We are here to consider the comparisons and contrasts drawn in those passages as referring, not to Jehovah, abstractedly considered, but to the *manifestations* he has given of his power, wisdom, and grandeur, in the scenes of the universe. Hence we are directed in the chapter from which our quotations are taken, to "lift up our eyes on high," and contemplate "the firmament of his power;" to "behold the hosts" of resplendent globes which he has dispersed throughout the regions of space "by the greatness of his strength," and to consider that the vast extent of the celestial spaces have been "meted out with a span." When the inspired writers demand from their hearers a sentiment of reverence and admiration,

they do not present to them metaphysical reasonings or abstract views in reference to the perfections of Jehovah, but describe those exhibitions of his power and grandeur which are calculated to strike the senses and imagination, and to excite the emotion intended. Thus, when the prophet Jeremiah wished to impress his hearers with a reverential sense of the greatness of God, he describes him by the *effects* of his power and wisdom as displayed in his operations. "Who would not fear thee, O King of nations! He hath made the earth by his power, he hath established the world by his wisdom, and hath stretched out the heavens by his discretion. When he uttereth his voice, there is a noise of waters in the heavens, and he causeth the vapors to ascend from the ends of the earth; he maketh lightnings with rain, and bringeth the wind out of his treasures."

In like manner, in the passages under consideration, we are to consider the contrast here stated as drawn, not between all nations and Jehovah as an abstract Being, whose perfections are infinite; for in this respect no comparison can be made, but as drawn between this earth with all its inhabitants, and the innumerable globes which are scattered throughout the regions of immensity. And the most enlightened astronomer, after his boldest excursions into the illimitable tracks of creation, could devise no language to express his emotions, and the contrast that subsists between this globe and the immensity of the heavens, more appropriate and energetic than the passage before us. This world, with "all that it inherits," is here represented as a single drop of water to the mighty ocean, or as a few particles of dust to the most spacious continents, when compared with the grandeur and immensity of nature; yea, to complete the contrast, it is "counted as nothing and less than nothing and vanity." When we survey the vast globes which compose the planetary system; when we wing our flight in imagination to the starry regions, and leave the sun and all his attendants behind us, until they dwindle to an undistinguishable point; when we prosecute our course through thousands of nebulae, every one of them containing unnumbered suns and systems; and when the mind is bewildered and overpowered at the immensity of the prospect, we cannot but perceive that the language of the prophet is the most impressive, and the fittest that could have been selected; that it is most emphatic, and literally true. But if this earth were the principal part of God's universe, there could be no propriety in such language, and it could be considered as allied only to extravagance and pompous declamation—a characteristic which ought never to be applied to the writers of the sacred records.

We ought likewise to consider that the contrast is not stated between the earth considered merely as a *material system*, and the amplitudes of the firmament, but between the *nations of the earth* and the innumerable order of beings which people the universe, plainly implying, in my apprehension, that unnumbered myriads of intelligences occupy the celestial worlds, in comparison of which all who now dwell upon the earth, or who have occupied its surface since time began, are only as a drop to the ocean. The passage before us may therefore be considered as almost a direct intimation of a plurality of worlds; and, if it could be proved that no other worlds existed, I should scarcely consider the strong language here used as the dictate of inspiration; but when we consider what appear to be the true references of the prophet's language, and the magnificent ideas it suggests, it conveys the most glorious and sub-

lime conceptions of the grandeur of "the high and lofty One who inhabiteth eternity," and whose presence fills the immensity of creation.

The next passage I shall adduce in support of the position under consideration, is Nehemiah ix, 6: "Thou, even thou, art Lord alone; thou hast made heaven, the HEAVEN OF HEAVENS, with all their host, the earth, and all things that are therein, the seas, and all that is therein, and thou preservest them all; and the HOST OF HEAVEN worshippeth thee."

Here the Most High is represented, not by a metaphysical exhibition of his infinity, eternity, and omnipotence, abstractedly considered, but by the *manifestations* he has made of himself in his wonderful operations, both in heaven and on earth; and this is the general, I may say universal, mode in which the sacred writers exhibit the character and perfections of the Deity. "Thou hast made heaven, the heaven of heavens, with all their hosts." By "heaven" is here to be understood the visible firmament, with all the stars and planets perceptible by the human eye, which is the sense in which the term heaven is generally taken when God is represented as its Creator. The "heaven of heavens" is an expression which is worthy of particular attention, and evidently includes in it an idea far more extensive and sublime than what most readers generally attach to it. It evidently intimates that, far beyond the visible starry heavens which we behold, there are unnumbered firmaments, composed of other stars and systems stretching out toward infinity on either hand, and which mortals in their present state will never be able to desery. We have already attained some glimpses of such firmaments. More than a hundred millions of stars, in addition to those distinguishable by the naked eye, are within the reach of the telescope, if all the regions of the sky were by this instrument thoroughly explored. We behold several hundreds, and even thousands of *nebulae* in different spaces of the heavens, each of them consisting of thousands of stars, which would form a firmament as glorious and expansive as that which appears to a common observer in the midnight sky; so that were we removed from one of those nebulae to another, we should behold at every stage a new firmament, composed of stars or other luminaries altogether different from what we had seen before, or from what we perceive in the firmament which is visible from our globe.—These facts, which have been brought to light by the discoveries of modern astronomy, while they display the infinite power and grandeur of the Divinity, serve likewise to illustrate many of the declarations of his word, and particularly such expressions as that before us,—"the heaven of heavens," the boundless empire of the "King eternal and invisible," in which he reigns over unnumbered intelligences. The same emphatical expression is used in the prayer of Solomon at the dedication of the temple: "But will God in very deed dwell on earth? Behold, the heaven and heaven of heavens cannot contain thee!" implying that far beyond the range of the material universe, vast and extensive as it is, the great Jehovah resides in the glory of his invisible attributes, filling immensity with his presence.

By "the host of heaven" is doubtless to be understood the inhabitants of those numerous worlds and vast regions here designated by the most emphatical expression which could be selected, "the heaven of heavens;" intimating that the same Almighty Being who launched into existence those innumerable globes also replenished them with countless orders of intelligent existence, capable

of enjoying his bounty, and offering to him a tribute of adoration. Hence it is here declared, "the host of heaven *worshipeth* thee;" evidently implying, if there is any rational idea to be elicited from the passage, that the bodies which compose "the heaven of heavens" are occupied with inhabitants; that these inhabitants are endowed with capacious powers of intellect; that their numbers correspond with the amplitude of the regions which they occupy; that most, if not all of them, are invested with the attribute of moral perfection, and are consequently in a state of happiness; that they employ their faculties in contemplating the perfections and operations of their Creator; and that they magnify and adore him in the loftiest strains, as the center and source of all their felicity: all which appears to be implied in the passage, "the host of heaven *worshipeth* thee." For no being can with propriety be said to worship Jehovah, unless such as are endowed with moral and intellectual powers, capable of appreciating his perfections, as displayed in the universe, and of perceiving that he is worthy of all homage and adoration. In accordance with such views the Psalmist, when his soul was inspired with the higher strains of devotion, in a sublime apostrophe, calls upon the whole intelligent universe to adore the name of Jehovah:—"Praise ye Jehovah from the heavens; praise him ye heaven of heavens,"—or, ye *inhabitants* of those higher regions,—*"praise him, all ye his angels; praise him, all ye his hosts. Let them praise the name of the Lord, for his name alone is exalted, and his glory is above the earth and heaven."* If therefore there were no other worlds than that on which we dwell, such magnificent expressions would lose all their sublimity, would be almost without meaning, and might be regarded rather as the turgid exclamations of an enthusiast than as the sober dictates of inspiration. But when we take into view the immensity of the universe, and the numerous worlds and beings it contains, such expressions, though among the strongest which human language can furnish, fall far short of communicating the lofty ideas they are intended to represent.

Such passages as the following may likewise be considered as embodying views of the same description:—Psalm ciii, 19,—*"The Lord hath prepared his throne in the heavens; and his kingdom ruleth over all."*

This, along with a number of similar passages interspersed throughout the Scriptures, evidently implies that *the heavens* form the principal part of the Divine empire, compared with which, this earth is but as a point, and "all its inhabitants reputed as nothing." They are represented as the chief and appropriate residence of Jehovah, where he displays the glory of his perfections to unnumbered intelligences. Hence he is declared to have *"established his throne in the heavens,"* intimating, that it is in those higher and more expansive regions that the principal arrangements of his government have been made, that the beneficence and rectitude of his character are manifested, and that the grandeur of his moral administration is most extensively displayed. But it is evident, that where there are no intellectual beings, there can be no moral government; and therefore, if the Almighty has a government in the heavens, these heavens must be peopled with beings endowed with moral and intellectual faculties, capable of being the subjects of a moral administration. To suppose a government without subjects, is evidently preposterous and absurd. It is added, *"His kingdom ruleth over all."* Where-

ever these expansive heavens extend, and however numerous and august the worlds and systems which lie within their range, they are all under the superintendence and sway of the Divine government, which extends its care and moral energies over the remotest regions of the universe. But as there can be no kingdom without rational and moral subjects, therefore, wherever the kingdom of Jehovah extends throughout the illimitable spaces of immensity, there must be myriads of beings endowed with rational and moral natures. Similar remarks might be made upon such declarations as the following:—"The Lord, he is *God* in the heaven above," intimating his rule or dominion over the worlds on high:—"Behold the heaven and the heaven of heavens is the Lord thy God's," intimating, likewise, that he presides in high authority over all the beings they contain;—"Thine, O Lord, is the greatness, and the glory, and the majesty; for all in heaven and in earth is thine. Thine is the kingdom, O Lord, and thou art exalted above all;"—"Heaven is my *throne* and the earth is my footstool;"—"His kingdom is an everlasting kingdom;"—"His dominion is an everlasting dominion;" and—"He doeth according to his will in the *army of heaven*, and among the inhabitants of the earth." All these, and similar passages, imply *rule* and *dominion* over the inhabitants of the heavens; and consequently intimate that the celestial worlds are occupied by the subjects of the Divine government. It is not improbable that the expression which so frequently occurs in Scripture, *"The Lord of hosts,"* or the Lord of armies, has a particular reference to the universal dominion of Jehovah over the countless myriads which people the distant regions of creation.

Psalm cxlv, 9:—"The Lord is good to all; and his tender mercies *are over all his works.*"

The goodness of God, in innumerable modes and instances, is displayed, not only toward man, but to all the diversified orders of animated existence in this lower world. But it is not confined to this terrestrial sphere, but is diffused wherever his wisdom and omnipotence have prepared habitations for sensitive and intellectual beings. Hence it is here declared, that "his tender mercies," or the emanations of his goodness and beneficence are diffused *"over all his works,"* implying that throughout the whole range of the material system, however far it may extend, the beneficence of the Deity is displayed to numerous ranks of his sensitive and intelligent offspring; for unless such beings exist throughout all places of his vast dominions, there could be no scope for the exercise of his benevolence, and of course, it could not be said, with propriety, to extend *"over all his works."* In the same point of view we may consider an analogous expression in Psalm cxvii, and other places of Scripture,—*"Thy mercy is great above the heavens;"* or, as Mr. Locke translates it, *"Great is thy bounty above the heavens;"* an expression which leads us to conclude, that far beyond these visible heavens which the unassisted eye beholds, and even beyond the reach of all the orbs which the telescope has enabled us to descry, the Divine goodness shines in rich manifestations, diffusing felicity and ecstatic joy among unnumbered legions of happy existence; for "bounty" or "goodness," can have a relation only to such beings.

In the following passage of Psalm cxiv, 10-13, it is declared, "All thy works shall praise thee, O Lord, and thy saints shall bless thee.—They shall speak of the glory of thy kingdom, and talk of thy power; to make known to the

sons of men his mighty acts, and the glorious majesty of his kingdom. Thy kingdom is an everlasting kingdom," &c.

This passage may be considered as embodying a prediction that in the future ages of the church men of piety will acquire more elevated and comprehensive views of the extent and the grandeur of the universal kingdom of Jehovah, and will display a more enlightened zeal than in ages past, in exhibiting to their fellow-men the august operations of Omnipotence, and the magnificence of that empire over which the Most High presides.—“They shall speak of the glory of Jehovah’s kingdom, and talk of his power.” If this kingdom were chiefly confined to the evanescent speck of earth on which we live, it would scarcely be worthy of the epithets which are here bestowed upon it. It is a kingdom of GLORY; it is a kingdom in which are displayed *mighty acts* or operations; it is a kingdom of *glorious majesty*; it is a kingdom in which are displayed “power,” and “*greatness which is unsearchable*;” it is a “kingdom of all ages,” and its administration will be carried forward throughout all the revolutions of eternity.—“thy kingdom is an *everlasting* kingdom.” Were its government conducted chiefly in reference to earth and its inhabitants, such descriptions of its grandeur could scarcely be expected from inspired writers, nor would such a limited kingdom correspond to the majesty of an infinite, omnipotent, and eternal Being, who has the range of immensity as the theater of his operations. But when we contemplate the universal kingdom of Jehovah extending throughout the unlimited regions of space; when we behold it filled with worlds of immense magnitude, and with systems of worlds in such a multitude and variety that no man can number them, we perceive at once that such a kingdom warrants the application of such lofty epithets and expressions as are here used; that it is indeed a kingdom displaying omnipotent “power,” and “*greatness unsearchable*;” that it is connected with “*mighty operations*,” that it is invested with “*glorious majesty*,” and that it is worthy of everlasting duration. But as the idea of a kingdom necessarily includes *subjects*, and as the multitude of subjects constitute the chief glory of an empire, so we must necessarily admit that all the provinces of this celestial kingdom are replenished with inhabitants, or in other words, *subjects* of the Divine government; without which it could have no “glory” nor “majesty,” nor could it with propriety be entitled to the designation of a “kingdom.”

Such passages as the following may likewise be considered as corroborating the preceding positions: Psalm cxlii, 4-6, “Who is like unto the Lord our God, who dwelleth on high? The Lord is high above all nations, and his *glory above the heavens*. He humbleth himself to behold the things that are in heaven and in the earth.” “Thy goodness is great above the heavens, and thy truth reacheth to the skies. Thou art exalted, O God, *above the heavens*,” &c.

These passages, and others of a similar import, embody the general idea that the omnipotence and grandeur of the Divinity are displayed in regions far beyond that firmament which is visible from our globe by common observers, yea, beyond the utmost limits to which telescopic discoveries have conducted us; for “his *glory is above*,” or beyond “these heavens.” And if nothing but empty space existed beyond these limits, or mere matter without mind, it could scarcely be said that the Divine *glory* is displayed beyond these heavens. It is further stated that the glory of the Almighty

is so expansive, and that his universal kingdom extends through regions so immeasurably distant that he may be said, speaking after the manner of men, “to *humble himself* when he beholds the *objects in the heavens*” which lie within our observation. This declaration contains not only a sublime representation of the magnificence of the Divine nature and operations, but appears to me to embody in it a demonstration of what we formerly asserted as highly probable—namely, that that portion of the universe which lies within the range of telescopic vision, and which contains so many millions of splendid suns and systems, is but a *small part* of the universal kingdom of Jehovah, compared with what lies beyond the utmost boundaries of human vision; for he is here represented as *humbling himself* when he looks down from the remoter glories of his empire on all that is visible to the view of mortals. To the same purpose is the pious exclamation of the Psalmist in the 8th Psalm: “O Lord, our Lord, how excellent is thy name in all the earth! *who hast set thy glory above the heavens!*” And if the glory of the Divinity be manifested in regions far beyond the visible firmament, we may rest assured that it consists in displaying his perfections, and communicating happiness to innumerable orders of rational beings, who are the subjects of his moral government.

I shall only further offer a few cursory remarks on the following passages:—Psalm xix, 1, “The heavens declare the glory of God,” &c. The word *glory* in this and similar passages, when applied to the Divinity, denotes the display of his wisdom, goodness, omnipotence, and other attributes. The heavens, with all the host of rolling orbs which they contain, are here declared to manifest the “glory,” or the infinite perfections, of Him who formed them. The number and magnitude of the opaque and luminous globes contained within the vast expansion of these heavens, and their astonishingly rapid motions, evidently proclaim his *omnipotence*; but if those bodies accomplished no end corresponding to the extent and grandeur of the means employed; if they were all so many expansive deserts, without any relation to intellectual existence, they could afford no evidences of wisdom and beneficence, and consequently could not be said, with any show of reason, to “declare the glory of God.” In the visions recorded in the Book of Revelation, the celestial inhabitants are represented as falling down before the throne of the Eternal in acts of adoration, and proclaiming, “Thou art worthy, O Lord, to receive glory, and honor, and power; for thou hast created all things.” And in another scene they are introduced as celebrating with rapture the Divine operations: “Great and marvelous are thy works, Lord God Almighty.”—“Blessing, and glory, and wisdom, and thanksgiving, and honor, and power, be unto our God for ever and ever.” Similar remarks to the above might be made in reference to these ascriptions of praise and adoration. If creation were a kind of chaos, or wilderness void of inhabitants, and if wisdom, design and goodness were not displayed in the Divine arrangements, there would be little to excite the *admiration* and devotional rapture of superior intelligences; and they could not be said with propriety to ascribe *wisdom*, and glory, and thanksgiving to God, while they beheld no display of some of these attributes in the mightiest of his works. But we are told in various passages of Scripture that the Most High “established the world,” or the universe, “by his wisdom, and stretched out the heavens by his



understanding." In Psalm cxlvii, 4, it is declared—"He telleth the number of the stars; he calleth them all by their names." It is evident that we are not to consider this declaration as expressive merely of an arithmetical idea or something similar to the practice of an astronomer, who distinguishes the stars by certain letters, characters or appellations; but as expressive of the intimate knowledge which the Almighty has of all those mighty orbs wherever dispersed throughout the regions of infinitude, and likewise his perfect acquaintance with all the intellectual beings, and the special arrangements connected with every one of them—a circumstance which conveys a most sublime idea of the omniscience and omnipresence of the Deity. Hence, in the words immediately following, the mind of the Psalmist, overpowered with this idea, bursts forth in this exclamation, "great is our Jehovah, and of great power; his understanding is infinite."

In the Epistle to the Hebrews, chapter i, 2, and xi, 3, a plurality of worlds is declared: "Through faith we understand that the worlds were framed by the word of God, and that the things which are seen were not made of things that do appear." The Greek word *αἰών*, in this passage, is sometimes used to denote an age or dispensation, but is also frequently used to designate the material world; in which sense it must be taken in the passage before us, as is evident from its connection, and from the subject on which the apostle is treating. It is to the visible or material world that our attention is here directed as having been produced from an invisible cause. The term *αἰώνες* being used in the plural number, evidently intimates that there are more worlds than one, and that there may be thousands or millions; but, independently of this direct intimation of a plurality of worlds, the passages formerly quoted, when viewed in a proper light, and considered in all their references and bearings, may be considered as conclusive proofs of the same position, and as intimating to us, not simply a plurality of worlds, but extending our views of their number and magnificence as far as science has yet conducted us, and even beyond the range of astronomical discovery; for we are told that the Divine perfections are displayed "above," or beyond, the utmost range of "the visible heavens."

Many other passages beside the above might have been pointed out as bearing on the same subject, but the remarks already made on the passages which have been selected may serve as a

key to illustrate many others, as they happen to occur to the intelligent student of the Scriptures. We read, for example, of the Almighty "operating, by his moral government and arrangements," "among the army," or armies, "of heaven," as well as "among the inhabitants of the earth;" and that the whole population of our world "is reputed as nothing in his sight." We find in different portions of the psalms, the inhabitants of the heavens, and "the heaven of heavens"—the "angels who excel in strength"—"all his hosts," or legions of intelligences, "in all places of his dominions, who do his pleasure, hearkening to the voice of his word,"—we find all these ranks of beings called upon to join in one united chorus of praise and thanksgiving to "Him whose name alone is exalted, and whose glory is above the earth and heaven." We read in the Book of Job, among many other descriptions of the grandeur of the Deity, that "by his spirit he garnished the heavens;" and that the astonishing displays of his omnipotence they contain "are but parts of his ways," and that "the thunder of his power none can understand." All of which representations, and many others, may be considered as embodying the idea, not only of a plurality, but of myriads of worlds existing in the universe.

There is one general remark which may be applied to all that we have stated in this chapter, and that is—*It is not necessary to suppose that the inspired writers had revealed to them all the wonders of modern astronomy.* They appear, in some instances, to have been ignorant of the precise meaning and the extensive references of the language they used. The prophets are said to have "inquired and searched diligently what manner of time the spirit of Christ which was in them did signify, when it testified beforehand the sufferings of Christ and the glory that should follow;" intimating that they were partly unacquainted with the precise references of the predictions they uttered. They were only the amanuenses of the Divine Spirit, and were directed to such language as was accordant with the Divine economy and with the facts existing in the universe, although they themselves might not be aware of the grandeur of those objects to which their expressions referred; and the correspondence of their language with the phenomena of the heavens and the earth, and the discoveries of modern times, constitutes one evidence among others of the truth of Divine Revelation.

## CHAPTER XVIII.

### ON THE PHYSICAL AND MORAL STATE OF THE BEINGS THAT MAY INHABIT OTHER WORLDS.

On the enunciation of this topic, some readers will probably, be apt to surmise, that the author is attempting to go beyond the range of subjects within which the human understanding should be confined. We have never seen the inhabitants of other worlds; we have been favored with no special revelations respecting them; we have not even caught a glimpse of the peculiar scenery of the globes in which they reside, excepting a few portions of their celestial phenomena; and while we are chained down by the law of gravitation to

this sublunary sphere, we cannot fly on the wings of a seraph to visit any of the distant orbs of the firmament. It is true, that on such a subject we cannot attempt to descend into particulars. But there are certain general and admitted principles on which we may reason, and there are certain phenomena and indications of design exhibited in the structure of the universe from which certain general conclusions may be deduced; beyond such generalities I do not intend to proceed, nor to indulge in vain conjecture.

There are many things of which we have acquired a certain degree of knowledge, and yet have never seen. We do not see the air we breathe, nor most of the gaseous fluids; we do not see the principle of life, or the rational spirit which animates our bodies; we cannot possibly see the Divine Being, although his presence pervades all space. But, in regard to all these objects, we have acquired a certain degree of information; and therefore, although we have never seen any of the inhabitants of other planets, and never will so long as we remain in our present abode, yet we may form some general conceptions respecting them, both as to their physical and moral state. All that I propose on this point may be comprehended under the following general remarks:

1. The planets, wherever they exist, in our own or in other systems, are inhabited by *sentient beings*. The formation of *material fabrics*, such as all the planetary bodies are, necessarily indicate that beings connected with *material vehicles* and organs of sensation were intended to inhabit them. The arrangements for the diffusion of light, heat, and the influence of the power of attraction, and other material agencies, evidently show that such agents were intended to act on beings formed with organical parts and functions, capable of being the recipients of impressions from them. All such beings, therefore, must be considered as furnished with bodies constructed with organical parts *analogous* to what we find in man or other animated beings on our globe; but the size and form of such bodies, the parts of which they are composed, the functions they respectively perform, their symmetry and decoration, and their powers of locomotion, may be very different from those which obtain in our sublunary world; and it is not unlikely, from a consideration of the *variety* which exists in the universe, that there is a certain difference, in these and other respects, in every planet and world that exists throughout immensity.

2. The principal inhabitants of the planets and other worlds are not merely sensitive beings, but are likewise endowed with *intellectual faculties*. This may be inferred from the scenery connected with their habitations. Connected with the planet Jupiter, we behold four splendid moons, larger than ours, performing their revolutions around it *in regular periods of time*, without the least deviation from their courses. The general aspect of these moons, their diversified phases and rapid changes, along with their frequent eclipses, must produce a sublime and variegated appearance in the nocturnal sky of that planet; while, from the surface of the moons themselves, the still more splendid appearance of Jupiter and the phases of the other moons will present a nocturnal scene of peculiar sublimity and magnificence. Connected with the planet Saturn, we find scenes still more august and diversified; beside seven large moons, two resplendent rings of vast extent surround the body of this planet, producing the most sublime and diversified phenomena, both to the planet itself and to all its satellites, adorning the firmaments of those bodies with a splendor and magnificence of which we can form but a faint conception.\* Were we permitted minutely to inspect the surfaces of these planets, we should doubtless find many beautiful arrangements in the scenery of nature with which they are adorned, probably far surpassing in picturesque variety and grandeur what appears on the surface of our

globe. When we inspect the surface of the moon through a good telescope, we behold a beautiful diversity of extensive plains, of lofty mountains, in every variety of size and form—of plains and valleys surrounded with circular ramparts of hills—of mountains towering far above, and vales and caverns sinking far below the general level of the lunar surface, with many other varieties; and we have only to suppose the general surface of that orb adorned with vegetable productions somewhat analogous to those of our globe, in order to present a scene of picturesque beauty and magnificence.

Now, it appears a natural, if not a *necessary* conclusion, that such grand and beautiful scenes could only be intended for the contemplation and enjoyment of beings endowed with rational natures, since mere sentient beings, such as the lower animals in our world, are insensible either to the beauties of the vegetable kingdom or the glories of the spangled firmament. If our globe had been created merely for the support of such beings, it is not probable that it would have been adorned with all the beautiful arrangements which now exist, and the splendid and diversified scenes with which it is furnished. The lion, the tiger, and the hyena find every accommodation they desire in dens, deserts, thickets, and forests; and they appear to feel no peculiar enjoyment in flowery fields, expansive lakes, beautiful landscapes, or the sublimities of a starry firmament. If, then, there were no rational intelligences in the planetary worlds, we cannot suppose that so many grand and magnificent arrangements as we find existing would have been made; particularly, we cannot suppose that the motions of the planets and their satellites would have been so accurately adjusted as to perform their revolutions with so much precision as we find they do. The regularity and precision of these motions are evidently intended to serve as accurate measures of *time* or duration,—a circumstance which must always be a matter of importance to rational beings wherever existing, but which seems to be scarcely attended to, and perhaps not in the least appreciated, by merely sentient beings, such as the lower orders of animated nature which exist around us.

From what has been now stated, we may conclude that the inhabitants of the planets are not *purely spiritual* beings; for pure spirits, entirely divested of material vehicles, cannot be supposed to have a permanent connection with any material world or system; nor could they be supposed to be affected by air, light, colors, attraction, or other material influences, which operate on the surfaces of all the planetary bodies. If pure intelligences, disconnected with matter, exist in the universe, they must be conceived to have a more expansive range than the limits of any one globe, and those material agencies which affect the organs of sensitive existence cannot be supposed to operate upon them; and, consequently, their modes of perception must be altogether different from those of organized intelligences. We may therefore with certainty conclude that the intelligent beings connected with the planetary worlds, either of our own or of other systems, are furnished with *bodies*, or corporeal vehicles of some kind or other. These may differ in size and form in different planets; perhaps their size may depend on the amplitude of space which the different planets may contain. But I cannot acquiesce in a supposition lately thrown out by a certain reviewer, "that in some worlds the inhabitants may be as large as mountains, and in others, as small as emmits." In the one case, comparatively few inhabitants could live in a

\* For a particular description of the scenes here alluded to, the reader is referred to "Celestial Scenery," ch. p. vii.

world where every one was a walking Mount Blanc or Mount Etna; and it would be contrary to all the known arrangements of the Creator; who appears to act on the principle of compressing into a small space the greatest degree of sensitive and intellectual enjoyment. Beside, such a huge mass of matter as a mountain is not only unnecessary, but in all probability would be highly injurious to the exercise of the intellectual faculties. In the other case, were rational beings as small as emmets, they could neither contemplate the beauties and sublimities of the scene of nature around them, nor the glories of the starry firmament; their range of vision could extend only a few feet or yards around them, and they never could be able to explore the nature, extent, and peculiarities of scenery of the world they inhabited. So that all such suppositions are evidently extravagant and absurd, being directly contrary to the proportion and harmony which exist in the universe, and which characterize all the arrangements of the Creator. In regard to the powers of locomotion, there may be considerable differences in different worlds. In many instances there is reason to believe their inhabitants are enabled to transport themselves from one region to another with a velocity far surpassing the locomotive powers of man. In the planet Venus some of the mountains are reckoned to be twenty-two miles in perpendicular elevation, from the top of which eminences the most sublime and diversified prospects must be enjoyed; and in order that its inhabitants may be enabled to ascend with ease such lofty elevations, it is not unreasonable to believe that they are endowed with powers of motion far superior to those of the inhabitants of our globe.

3. The inhabitants of the planets are furnished with organs of sensation, particularly with the *organ of vision*. This may be certainly deduced from the fact, that there are connected with the planets arrangements for the equable *distribution of light*. The sun, the source of illumination, is placed in the center of the system for diffusing light in certain proportions over the surfaces of all the planets, their satellites, and their rings. Each planetary body revolves round its axis, in order that every part of its surface may alternately enjoy the benefit of the solar radiation. Around the larger planets are moons for the distribution of light in the absence of the sun; and one of them is invested with a double ring, which reflects the solar rays during the night both on the surface of the planet itself and on the surfaces of its moons. This diversified apparatus for the diffusion of light evidently appears to be an arrangement of *means* in order to the accomplishment of an important *end*; for it would be a reflection on the character of the All-wise Contriver to suppose that means have been arranged where no appropriate end is intended to be accomplished; but all the arrangements for the regular and equable diffusion of light have been made in vain, if there be no *eyes* or organs of vision on which light may act; for mountains, and vales, and barren deserts do not require its regular influence. That there are beings furnished with visual organs throughout all the worlds and systems of matter in the universe appears from the consideration, that not only in our own system, but among the myriads of fixed stars dispersed throughout immensity, provision is made for such organs in the existence of *light*, which is a substance that appears to be universally diffused throughout creation. It is found by experiment, that the light which radiates from the most distant star is of the same nature

as that which emanates from the sun. It is refracted and reflected by the same laws, and consists of the same colors, as that which illuminates the bodies which compose the solar system, and which throws a luster on the objects immediately around us. The mediums of vision must therefore be acted upon by light, in the most distant regions of creation, in nearly the same manner as with us, although there may be numerous varieties and modifications of the visual organs, so as to render vision far more perfect and extensive than in the case of the inhabitants of our globe. We find that there is an immense variety in the modes of vision among the lower animals. Some of the smaller insects have their eyes nearly of a globular form and very small, so that they can see only a few inches around them; while the eyes of other animals, such as the eagle, are so constructed that they can perceive their prey at a great distance, and from a very elevated position. Some animals have only one or two visual organs or eye-balls, as man, birds, and quadrupeds; others have eight, as in the case of spiders; and others have several hundreds, and even thousands, of transparent globules, each of which is capable of forming a distinct image of any object, as is the case with flies, butterflies, and other insects. All these diversified constructions of the organs of vision, however, perform their functions according to the same invariable laws of optics.

But although light must act on the eyes of all organized beings in a manner somewhat similar, or at least analogous to what it does on our organs, yet there may be certain configurations of the organ of vision by which a more glorious and extensive effect is produced than by the human eye. The inhabitants of some other worlds, instead of being confined in their range of vision as we are, may be able to penetrate through space to an indefinite extent, and to perceive with distinctness all the prominent objects connected with neighboring worlds; and even the peculiarities of distant suns and systems may be within the range of their view. The *difference* between the eye of an insect, which sees only an inch or two around it, and the eye of a man, which can grasp at once an extensive landscape, is perhaps as great as the difference between the vigor and extent of human eyes and such organs of vision as I have now supposed. And who shall set boundaries to the mechanisms of infinite wisdom, especially when we consider the varieties which exist in our terrestrial system? It is not beyond the limits of probability that an inhabitant of Jupiter may be able to perceive and to trace all the variety of scenery connected with Saturn, and its rings and satellites, and to distinguish the planets that revolve around other suns, as distinctly as we perceive with a telescope the satellites with which that planet is attended. We have experimental proof that the inventions of art can extend the range of human vision. The rings of Saturn, the motions of its satellites, the changes which happen in the belts of Jupiter—which no unassisted eye could ever have discerned,—and millions of stars a thousand times more distant than the limits of natural vision, have been brought to view by the invention of the telescope; which shows that the extent of human vision is susceptible of an indefinite increase. And if man can thus improve his natural vision, we need not doubt that the Deity has infinite resources at his command, and that when he pleases, he can construct visual organs of such vast and extensive powers as far surpass the limits of our comprehension; and it is not improbable, from the vari-

ety already known to exist, that such organs are actually to be found throughout different regions of the universe. Our extent of vision by the telescope is found to depend on the extent of area contained in the object-glass, or speculum of that instrument, which enables the eye to take in a greater portion of rays from distant objects than it can do in its natural state; and therefore, if our eyes were formed with pupils of a large dimension, and with a corresponding degree of nervous sensibility in the retina, we might be enabled to penetrate into space to an extent of which we have no conception. Such modifications of vision, and thousands of others, are obviously within the power of Him who at first organized all the tribes of animated existence.

It is highly probable that it is one great design of the Creator to exhibit to all intelligent beings throughout creation a visible display of his glory through the medium of their visual organs; for where no organs of vision exist, the wonderful apparatus for the production and distribution of light so conspicuous throughout the universe, exists in vain; and, therefore, if it be allowed to reason from the means to the end, or from the cause to the effect, we must admit that the universal diffusion of light through infinite space, from an infinite variety of bodies, must be intended to produce vision through the medium of organs similar or analogous to ours; in order that rational beings may enjoy the pleasures arising from this sense, and be enabled to appreciate the wonders of the universe, and the perfections of its Creator. The variety of means and contrivances for the diffusion of *light* throughout creation is therefore a demonstrative evidence both of the *existence* of intelligent beings in other worlds, and that they are furnished with visual organs for the purpose of contemplating the objects which it renders visible.

4. The inhabitants of other worlds are invested with *locomotive powers*. This we may infer from the amplitude of space which every world contains, and from the consideration that they are social beings, and hold a regular intercourse with each other. We must, indeed, necessarily suppose that there are no rational beings confined to one spot or point of space, as a tree, a shrub, or any other vegetable; for if this were the case, there could be no improvement either in knowledge or in moral action, the capacity of the intellect could never be expanded, the variety of beauties and sublimities which distinguish all the works of God could never be properly contemplated, most of the pleasures peculiar to an intelligent being could never be enjoyed, and the manifold delights which flow from social intercourse and the contemplation of diversified scenes and objects could never be experienced. The supposition of an incapacity for local motion is therefore inconsistent with the idea of a rational being, and almost involves an absurdity. We find, moreover, that in many of the planets, particularly in Jupiter and Saturn, there is the most ample space provided for exercising the powers of locomotion; these two planets containing more than 220 times the area of the earth's surface, which affords a vast field for excursion, and for observation to their inhabitants. These locomotive powers may be very different from those of man, both in their fleetness and in their mode of operation. We have reason to believe that in many instances they will far exceed ours in swiftness, and in the ease with which they may be performed; for if birds and flying insects, and even certain quadrupeds, are endowed with powers of motion far

more swift and energetic than those of man, it is highly probable that rational and social beings, in more expansive worlds than ours, are capable of traversing space with much more ease and agility than the human inhabitants of our globe, otherwise they could not be supposed for ages to accomplish a survey of the world in which they dwell, or to become acquainted with its leading features. Whether such motions, however, are performed on a principle analogous to that on which the wings of birds are constructed, or on any other principle to us unknown, is beyond our province to determine.

5. We may also infer that the inhabitants of other worlds are furnished with a sense corresponding to the *organ of hearing*, and a *faculty of emitting articulate sounds*. Without such a sense and faculty, it is scarcely possible to conceive that social intercourse, and a mutual interchange of sentiment and feeling could be carried on to any extent, or with any great degree of pleasure or improvement, among organized beings. Pure spirits may have modes of intercourse and of communicating thought peculiar to themselves, of which we can at present form no distinct conception; but organized intelligences must necessarily have some *material* mediums, or faculties, by which sentiments and emotions may be expressed and communicated. Some of the planets are found to be environed with atmospheres; and as air is the medium of sound in our terrestrial region, it doubtless serves a similar purpose in other worlds; and consequently we may conclude that the animated beings they contain are furnished with organs for the perception of sounds in all their modulations. In the representations given in the sacred records of the exercises of superior beings, they are exhibited as uttering articulate sounds, and joining in the harmonies of music. When a multitude of angels descended on the plains of Bethlehem to announce the birth of Messiah to the shepherds, they uttered articulate sounds, and joined in musical strains which struck the ears of the shepherds, and conveyed a distinct impression of the meaning of the sentiments communicated; which circumstance leads us to conclude, that superior intelligences in other regions express sentiments and emotions in a manner somewhat similar to that in which we hold intercourse with one another, by the faculties of speech and hearing.

6. It might, perhaps, be inferred from the *rotation* of the planets—which produces the alternations of light and darkness—that their inhabitants are subject to something analogous to *sleep*, or stated intervals of repose. This may probably be the case in some of the planets, such as Mars or Mercury, which are unaccompanied with satellites; but we know too little of the peculiar circumstances of other worlds to warrant us to speak decisively on this point, as the bodies of the inhabitants of other planets may be so constructed as not to stand in need of being daily invigorated by repose as the bodies of men. Beside, the celestial scenery of some of the planets is so grand, diversified, and picturesque, that a considerable part of their studies and social pleasures may be prosecuted and enjoyed amidst the solemn grandeur and beautiful diversity of their nocturnal scenes, and their contemplations directed to the interesting objects then presented to their view. This is probably the case in the regions of Jupiter and Uranus,—particularly in Saturn, where seven moons may occasionally be beheld in the nocturnal heavens, all exhibiting different *phases*,—some of them changing their apparent

phases, magnitude, and motion with great rapidity; some of them entering into an eclipse; and others emerging from it; while two stupendous rings stretch across the concave of the sky, presenting every moment different objects on their surface in the course of their rapid diurnal revolution. Such scenes will, perhaps, be more interesting to the inhabitants of this planet than all the splendors of their noonday;\* for all the objects on the surface of this planet, and likewise those on Jupiter and Uranus, will present a different aspect from what they do in the daytime. Being illuminated by the light reflected from a retinue of moons, and by the still more effulgent splendor emitted from the spacious rings, every object will appear enlightened and distinctly visible, a diversity of coloring will be exhibited by the diversity of reflected rays proceeding from the different moons and rings, and the shadows of objects will be increased and blended together, and thrown in different directions, according to the number and relative positions of the nocturnal luminaries which may happen to be above their horizon. On which account, I should be disposed to conclude that the inhabitants of such planets have their physical constitutions organized in such a manner by Divine Wisdom as to fit them for perpetual activity, without standing in need of any repose similar to that of sleep.

The above cursory remarks respecting the physical state of the planetary inhabitants have been deduced chiefly from the ascertained circumstances and phenomena of the planets, and from the general constitution and economy of the universe. Several other conclusions might likewise have been deduced, but I do not intend to enter into the regions of mere conjecture. As rational and intelligent beings, the inhabitants of other worlds must necessarily be considered as prosecuting the study of useful science in reference to all those departments of nature which lie open to their inspection, and that they exercise their mental faculties in such pursuits and investigations. If this be admitted, then we must necessarily conclude that they use all the requisite means for the investigation of truth, and for progressing in knowledge. If, for example, they engage in the study of astronomy (as we have reason to believe the inhabitants of all worlds do) they must make observations, both general and particular; and in order to do so with accuracy and precision, instruments of various descriptions are requisite, and the management of these requires the use of hands, or some bodily parts answering a similar purpose; for none of the lower animals on our globe that are deficient in such a member could perform the operations of art which man can perform by the use of his hands. If a horse or a bear were furnished with the same intellectual faculties as the human race, and still retain its present organization, it could make little or no progress either in science or art, without members corresponding to human hands; and therefore we may confidently conclude that members similar or analogous to these are common to us and to the planetary inhabitants. The study of astronomy likewise supposes an acquaintance with *geometry*. The truths of geometry must be the same in every region of the universe, and perhaps of equal utility to the inhabitants of the most distant worlds as to man on earth. They are truths which are eternal and unchangeable, and which no locality or circumstances within the limits of

creation can possibly alter or modify; and therefore must be recognized, in a greater or less degree, by every rational being. The Creator himself has laid the foundation of this science, for he presents us in his works with geometrical figures of various descriptions,—with circles, squares, parallelograms, hexagons and polygons—with ellipses, spheres, spheroids, and other figures, and proposes them, as it were, to our study and contemplation. With geometry, *arithmetic* and other sciences are intimately connected, so that the study of the one supposes that of the other. In short, truth, and every branch of knowledge by which the mind of a rational being can be adorned, must be *substantially* the same in every world throughout the amplitudes of creation.

Some persons, however, may be disposed to object, that the inhabitants of other worlds may see all truths *intuitively*, and that they may have no need to use any means, as we are obliged to do, to acquire and to make progress in knowledge, and that they acquire all their knowledge at once without any exertions,—opinions which have been frequently broached by divines, in reference to the happiness of the future world. But there appears no foundation for such opinions. We have reason to believe that every intellectual being throughout creation *exerts* its powers for the acquisition of truth, and that its advancement in knowledge is *progressive*; for its faculties were bestowed for the very purpose that they might be exerted on all the different objects and manifestations of the Divinity within its reach; and if all knowledge were intuitive and required no exertion of the mental faculty, the individual would be reduced to something like a mere machine, and would be deprived of the pleasures which arise from mental research and investigation. There must likewise be a *progress* in knowledge, arising from the consideration of the immensity of the Divine Being, and of his works, and of the limited nature of finite intelligences. No finite being can ever grasp the incomprehensible Divinity, or the immensity and variety of his operations throughout boundless space; but it may always be *advancing* to a more comprehensive view of the perfections and the empire of the Eternal, and may thus go on from one degree of knowledge to another, gradually approximating *toward* perfection during all the periods of an immortal existence, but will never reach it; and its happiness is connected with this circumstance, that it will never reach perfection, or obtain a *full discovery* of all the glories of the Divinity. But this gradual progression and expansion of intellectual views will be a perennial source of felicity to all virtuous intelligences. Whereas, were the whole of their knowledge acquired at once, or after a short period of duration, the mind would flag, mental activity would cease, the prospect of future knowledge and enjoyment would be cut off, and misery to a certain extent would take possession of the soul.

In fine, although there are, doubtless, marked differences between the planetary inhabitants and the inhabitants of our globe, and although the natural scenery of those worlds may be considerably different from ours, yet it is not improbable, were we transported to those abodes, that we should feel more at home in their society and arrangements than we are now apt to imagine, provided we were once made acquainted with their language, or mode of communicating their ideas. For there are certain relations, sentiments, dispositions and virtues, which must be common to intellectual and moral beings, wherever existing

\* For a particular description of these scenes, the reader is referred to "Celestial Scenery," chap. viii.

throughout the material universe. In respect to bodily stature and appearance, we might be apt to suspect that there would be many striking differences in the aspect of the inhabitants of another planet, and that strange and novel forms of corporeal organization would everywhere be presented to view; yet it is just as probable that in such a world we should contemplate beings not much unlike ourselves, and animated by similar or analogous views, sentiments, and feelings, though placed in circumstances and surrounded with a scenery very different from those of our sublimary region.

Whether we may ever enjoy an intimate correspondence with beings belonging to other worlds, is a question which will frequently obtrude itself on a contemplative mind. It is evident that, in our present state, all direct intercourse with other worlds is impossible. The law of gravitation, which unites all the worlds in the universe in one grand system, separates man from his kindred spirits in other planets, and interposes an impassable barrier to his excursions to distant regions, and to his correspondence with other orders of intellectual beings. But in the present state he is only in the *infancy of his being*; he is destined to a future and eternal state of existence, where the range of his faculties and his connections with other beings will be indefinitely expanded. "A wide and boundless prospect lies before him," and during the revolutions of an interminable duration, he will, doubtless, be brought into contact and correspondence with numerous orders of kindred beings, with whom he may be permitted to associate on terms of equality and of endearing friendship. All the virtuous intelligences throughout creation may be considered as members of one *great family*, under the peculiar care and protection of the UNIVERSAL PARENT; and it is not improbable, that it is one grand design of the Deity to promote a regular and progressive intercourse among the several branches of his intelligent offspring, though at distant intervals and in divers manners, and after the lapse of long periods of duration.

Such an intercourse may be necessary, in order to the full expansion of the moral and intellectual faculties, and to the acquisition of all that knowledge which relates to the attributes of the Divinity, and the physical and moral government of the universe. For this purpose it may be necessary that branches of the universal family that have existed in different periods of duration, and in regions widely separated from each other, should be brought into mutual association, that they may communicate to each other the results of their knowledge and experience, the diversity of physical and moral circumstances in which they have been placed, and the different arrangements of God's moral government to which they have been respectively subjected. Such views correspond with the representations given in Scripture in reference to the heavenly state. The spirits of "just men made perfect" are represented as joining the society of "an innumerable company of angels," which are only another order of rational beings; and in the visions of celestial bliss, recorded in the book of Revelation, both men and the angelic hosts are exhibited as forming one society, and joining in unison in celebrating the perfections of Him who sitteth on the throne of the universe.

But should the laws of the physical system, and the immense distances which intervene between the several worlds, prevent such associations as I have now supposed, there may be another economy, superior to the physical, which may consist

with the most extensive and intimate intercourse of all rational and virtuous beings. There may be a *spiritual economy* established in the universe, of which the physical structure of creation is the basis or platform, or the introductory scene in which rational beings are trained and prepared for being members of the higher order of this celestial or intellectual economy. It appears highly probable that the first introduction of every rational creature into existence is on the scene of a *physical economy*. The diversified scenes and relations of the material world appear to be necessary, in the infancy of being, to form a substratum for thought, or to afford scope for the exercise of the moral and intellectual powers, or materials on which these powers may operate, and likewise for exhibiting a *sensible display* of the character and perfections of the Almighty.—The knowledge which may thus be acquired of the scenes and relations of the universe, and the attributes and moral government of its Omnipotent Author, in the course of myriads of ages, must be great and extensive beyond what we can well conceive. This knowledge and experience of physical objects and relations may prepare the rational soul for entering on the confines of a higher and nobler economy, where *immaterial scenes and relations*, and particularly the attributes of Divinity, abstractly considered, may form the chief objects of research and contemplation. Under such a state of economy, we may conceive that intellectual beings, to whatever portion of the material universe they originally belonged, may hold the most intimate converse with one another, by modes peculiar to that economy, and which are beyond the conceptions of the inhabitants of the physical universe; so that distance in point of space shall form no insuperable barrier to the mutual communication of sentiments and emotions.

On grounds similar to those now stated, we might conceive it as not altogether improbable, that the spiritual principle which animates the lower orders of animated nature, and which in some cases bears a near resemblance to the reason of man, may be susceptible of indefinite expansion and improvement by being connected with a superior organization, and that such beings may ultimately pass through various gradations of rank in the physical and intellectual economy, until they arrive at a station superior to that of the most enlightened and improved human beings. But as we are now bordering on the regions of doubt and uncertainty, suffice it to say, that it appears highly probable, from a consideration of the Divine benevolence, of the relations which subsist throughout the physical and intelligent system, and of the intimations contained in the records of revelation, that virtuous and holy intelligences, from different regions of the material creation, as brethren of the same great family, shall, at one period or another, hold the most intimate converse and communion, and rehearse to each other their mutual history and experience. Such intercourse would evidently enhance that felicity which it is the great design of the Creator to communicate, and the means by which it may be effected are obviously within the limits of infinite Wisdom and Omnipotence.

#### ON THE MORAL STATE OF THE INHABITANTS OF OTHER WORLDS.

The moral state of intellectual beings in other worlds is a subject of still greater interest and importance than their physical state and constitution,

and the scenes of nature with which they are surrounded; for on the moral temperament of such beings, and the passions and affections they display, will chiefly depend the happiness of the intelligent system throughout every region of the universe. It is possible to suppose a region of creation furnished with everything that is grand, beautiful and magnificent, and calculated to gratify in the highest degree the senses and imagination, and yet the abode of wretchedness and misery. If passions and dispositions similar to those which actuate the most vicious and depraved class of mankind were universally to prevail in any world, however beautiful and sublime its physical arrangements, true happiness would be banished from its society, and misery, in all its diversified ramifications, would be found pervading its abodes. Even the tempers and dispositions which are frequently exhibited in polished society, and by some men who call themselves Christians and philosophers,—jealousy, emulation, envy, pride, revenge, selfishness, and such like,—were they to reign uncontrolled in any region, would soon transform intellectual beings into an assemblage of fiends, and banish true enjoyment from every department of the social system.

If these sentiments be admitted, it will follow, that were we permitted to range through any of the planetary worlds, the pleasures and enjoyments of such an excursion would chiefly depend on the character and dispositions of those who accompanied us, and of the inhabitants of the planet through which we roamed. Were we to be treated by the inhabitants of another world in the same way as Mr. Park was treated by the Moors when he was traversing the wilds of Africa, or as a poor wretched foreigner is sometimes treated in our own country, we should find little enjoyment amidst all the beauties and novelties of scenery which might meet our eye in such a world, for upon the affections and conduct of intelligent beings toward one another must depend the happiness of individuals, and of the whole social system throughout every department of creation.

It is probable that the greater part of the inhabitants of all worlds are in a state of innocence, or, in other words that they remain in that state of moral rectitude in which they were created; for we may assume it as an axiom that every rational being, when first ushered into existence, is placed in a state of innocence or moral rectitude, without any natural bias to moral evil. To suppose the contrary would be to admit that the Divine Being, who is possessed of perfect holiness and rectitude, infuses into rational beings at their creation a principle of sin, or a tendency to moral evil, which would be inconsistent with every scriptural view we can take of the character of God. Such beings, therefore, so long as they continue in their primal rectitude, are in a state of happiness; and every arrangement of the Creator in relation to them must be conceived as having a direct tendency to promote their sensitive and intellectual enjoyment. Moral evil, however, has been introduced into the universe, and we know by experience many of its malignant and miserable effects. For anything we know to the contrary, the operation of this principle *may be felt* in some other worlds beside our own, though we have reason to believe, from a consideration of Divine goodness, that its effects are not very extensive. Its introduction into the world has doubtless been permitted in order to bring about a greater good to the universe at large than could have been accomplished without it, in order to

exhibit to the intelligent system a display of the miserable and extensive effects which necessarily flow from a violation of the original moral laws given forth by the Creator, and to demonstrate the indispensable necessity of a universal adherence to these laws, in order to secure the harmony and the happiness of the intelligent universe.

In conformity to the axiom stated above, we must necessarily suppose that rational beings, wherever existing, were created in perfect moral purity, and had a law or laws impressed upon their minds congenial to the holiness of the Almighty Creator, and calculated to promote the moral order of the intelligent system, and consequently the happiness of every individual belonging to it. *Moral order* consists in the harmonious arrangement, disposition, and conduct of intelligent beings, corresponding to the relations in which they stand to one another and to their Creator, and calculated to promote their mutual happiness.—Wherever moral order prevails, every being holds its proper station in the universe, acts according to the nature of that station, uses its faculties for the purpose for which they were originally intended, displays dispositions and emotions toward fellow-creatures and the Creator corresponding to the respective relations in which they stand, and endeavors to promote enjoyment among all surrounding beings.\* For the purpose of securing moral order, certain moral laws must be supposed to be promulgated by the Creator, or at least written upon the hearts of all rational beings, as principles of action, to regulate all the movements of the intelligent system. These laws must be *substantially* the same as to their general bearings throughout all the worlds in the universe.

But, it may be asked, what are those general laws to which I allude, and have they ever been promulgated to man upon earth? I answer, they have actually been revealed to the inhabitants of our globe by the highest authority, and reason can demonstrate their applicability to all worlds. They are these—"THOU SHALT LOVE THE LORD THY GOD WITH ALL THY HEART, AND WITH ALL THY MIND, AND WITH ALL THY STRENGTH. This is the first and great commandment. And the second is like unto it: THOU SHALT LOVE THY NEIGHBOR AS THYSELF." These laws are not to be considered as confined merely to the regulation of the affections and actions of human beings, but to every individual of the moral system, wherever existing; for we cannot for a moment suppose that laws directly opposite to these would be given by the Creator to any class of intelligences. It would be inconsistent with everything we know of the character of the Divinity to imagine that he would promulgate to any class of beings such laws as these:—"Thou shalt hate thy Creator," and "thou shalt hate all thy fellow-creatures." And if such an idea would evidently involve in it a glaring inconsistency and absurdity, then it follows that the very opposite of such injunctions must be the general principles which govern the inhabitants of all worlds that have retained their allegiance to their Creator. There is not a single being possessed of a rational nature, either in the planetary system to which we belong or to any other system throughout the sidereal heavens, but is under indispensable obligations to regulate its conduct by the two general laws or principles to which we have referred, and to yield a complete and unreserved obedience to all that is included in such re-

\* For a particular illustration of *moral order*, the reader is referred to "The Philosophy of Religion," *Preliminary Definitions*, Sect. i.

quisitions. Wherever such obedience is complete, order, harmony, and happiness are the natural and necessary results; but could we suppose these laws reversed, and the inhabitants of any worlds to act on principles directly opposite, a scene of anarchy, confusion, and misery would ensue, which would completely disorganize the social system, and render existence a curse rather than a blessing; and in worlds where those laws are *partially* violated, as in the world in which we dwell, disorder and misery will be the result in proportion to the frequency and extent of their violation.

These are the laws by which not only man on earth, but all "the principalities and powers of heaven," are governed and directed, and by which they are bound to regulate all their thoughts, affections, and conduct. The lowest orders of rational existence come within the range of these universal laws, and the highest orders of the seraphim are not beyond their control. As the law of gravitation extends its influence throughout all the planetary worlds, and even to the remotest stars, uniting the whole in one harmonious system, so the law of universal *love* diffuses its influence over the intelligent universe, uniting the individuals who are subject to its sway in one harmonious and happy association. Hence it follows, that were we completely animated by this noble principle, and were we permitted to visit those worlds where it reigns supreme, and to mingle with their inhabitants, we should be recognized as friends and brethren, and participate of all those pleasures and enjoyments of which it is the source. The full recognition, then, of the laws to which we have referred, and their complete and uninterrupted influence over the moral powers, may be considered as qualifying the individual for being a citizen of the great moral universe, and for associating with all holy beings throughout the wide empire of omnipotence, should he ever be permitted, at any period of duration, to visit other worlds, and mingle with other orders of rational intelligences.\*

These laws, in reference to the inhabitants of our world, diverge into numerous ramifications. The precepts of the moral law, or the ten commandments, are so many branches of moral duty flowing from these first principles; and in the discourses of our Saviour and the practical parts of the apostolic epistles they diverge into still more specific and minute ramifications, bearing upon all the diversified relations of life and the various

circumstances connected with moral conduct.— But all the particular rules and precepts alluded to are resolvable into the general principles or affections stated above, and bear the same relations to each other as the trunk of a tree to its branches, or as a fountain to the diversified streams which it sends forth. In other worlds relations may exist different from those which are found in human society, and consequently particular precepts, different from ours, may form a part of their moral code, while certain relations which obtain among us may have no place among other orders of beings, and of course, the precepts which particularly bear upon such relations will be in their circumstances altogether unnecessary. But we may rest assured that all the particular precepts, applicable to whatever circumstances and relations may exist in other regions of creation, will be founded on the universal principles to which we have adverted, and be completely conformable to their spirit, and to the benevolent designs they are intended to accomplish.

In all those worlds where the love of God and of fellow-intelligences reigns supreme, the inhabitants may be conceived to make rapid improvements in knowledge; for the malignant principles and passions which prevail among men have, in numerous instances, been the means of retarding the progress of useful science and its diffusion throughout society. But where love in all its emanations pervades every mind, society will unite and harmonize in the prosecution of every plan by which the intellectual faculty may be irradiated and happiness diffused. Beside, in such a state of society, truth will be forever triumphant and falsehood unknown. Every fact will be fairly and truly exhibited without deception, or the least tendency to misrepresentation or exaggeration. There will be the most complete reliance on personal evidence in regard to every fact and circumstance which has been witnessed by any individuals; for want of which confidence in our world, the rational inquirer has been perplexed by the jarring statements of lying travelers and pretended philosophers; erroneous theories have been framed, the mists of falsehood have intercepted the light of truth, the foundations of true knowledge undermined, and science arrested in its progress toward perfection. All such evils, however, will be unknown in worlds where the inhabitants have arrived at moral perfection.

In fine, from what has been now stated, we may conclude that the *spirit*, the *principle*, and *essence* of our holy religion, as delineated in the Scriptures, must be common to all the inhabitants of the universe who have retained their primeval rectitude and innocence.

\* For more particular details on this subject, the reader is referred to "The Philosophy of Religion;" particularly *Chapt. ii, Sect. vi.*



## CHAPTER XIX.

### A SUMMARY VIEW OF THE UNIVERSE.

HAVING in the preceding pages afforded a few sketches in reference to the principal facts connected with the sidereal heavens, which constitute the most extensive portion of creation within the limits of our knowledge, it may not be inexpedient to take a summary view of the range of objects to which our attention has been directed, in order to direct our occasional reflections on this subject, and to enable us to form an approximate, though faint and limited, idea of that universe over which Omnipotence presides, and of the perfections of its adorable Author.

We can obtain an approximate idea of the universe, only by commencing a train of thought at those objects with which we are more immediately conversant, and ascending gradually to objects and scenes more distant and expansive. We are partly acquainted with the objects which constitute the landscape around us, of which we form a part,—the hills, the plains, the lofty mountains, the forests, the rivers, the lakes, and the portions of the ocean that lie immediately adjacent. But all the range of objects we can behold in an ordinary landscape forms but a very small and inconsiderable speck, compared with the whole of the mighty continents and islands, the vast ranges of lofty mountains, and the expansive lakes, seas, and oceans which constitute the surface of the terraqueous globe. It would be requisite that more than *nine hundred thousand landscapes*, of the extent we generally behold around us, should be made to pass in review before, and a sufficient time allowed to take a distinct view of the objects of which they are composed, ere we could form an adequate conception of the magnitude and the immense variety of objects on the whole earth. Were only twenty minutes allotted for the contemplation of every landscape, and ten hours every day, it would require ninety years of constant observation before all the prominent objects on the surface of the globe could thus be surveyed. Were it possible to take a distinct mental survey of such a number of landscapes, we might acquire a tolerable conception of the amplitude of our globe, and it would serve as a standard of comparison for other globes which far excel it in magnitude. But, I believe, very few persons are capable of forming, *at one conception*, a full and comprehensive idea of the superficial extent of the world in which we dwell, whose surface contains no less than one hundred and ninety-seven millions of square miles. The most complete conception we can form must indeed fall very far short of the reality.

But however ample and correct our conceptions might be, and however great this earth might appear in the view of the frail beings that inhabit it, we know that it is only an inconsiderable ball, when compared with some of the planetary bodies belonging to our own system. One of these bodies would contain within its dimensions nine hundred globes as large as this earth,—another, fourteen

hundred of similar globes; and were five hundred globes, as large as that on which we dwell, arranged on a vast plain, the outermost ring of the planet Saturn, which is 643,000 miles in circumference, would inclose them all. Such are the vast dimensions of some of those bodies, which appear only like lucid specks on the concave surface of our sky. This earth, however, and all the huge planets, satellites, and comets, comprised within the range of the solar system, bear a very small proportion to that splendid luminary which enlightens our day. The sun is five hundred times larger than the whole, and would contain within its vast circumference thirteen hundred thousand globes as large as our world, and more than sixty millions of globes of the size of the moon. To contemplate all the variety of scenery on the surface of this luminary, would require more than fifty-five thousand years, although a landscape of five thousand square miles in extent were to pass before our eyes every hour. Of a globe of such dimensions, the most vigorous imagination, after its boldest and most extensive excursions, can form no adequate conception. It appears a kind of universe in itself; and ten thousands of years would be requisite before human beings, with their present faculties, could thoroughly investigate and explore its vast dimensions and its hidden wonders.

But great as the sun and his surrounding planets are, they dwindle into a point when we wing our flight toward the starry firmament. Before we could arrive at the nearest object in this firmament, we behoved to pass over a space at least twenty billions of miles in extent,—a space which a cannon ball, flying with its utmost velocity, would not pass over in less than four millions of years. Here every eye, in a clear winter's night, may behold about a thousand shining orbs, most of them emitting their splendors from spaces immeasurably distant; and bodies at such distances must necessarily be of immense magnitude. There is reason to believe that the least twinkling star which our eyes can discern is not less than the sun in magnitude and in splendor, and that many of them are even a hundred or a thousand times superior in magnitude to that stupendous luminary. But bodies of such amazing size and splendor cannot be supposed to have been created in vain, or merely to diffuse a useless luster over the wilds of immensity. Such an idea would be utterly inconsistent with the perfections of the Divinity, and all that we know of his character from the revelations of his word. If this earth would have been "*created in vain*," had it not been inhabited,\* so those starry orbs, or, in other words, those magnificent suns would likewise have been created in vain, if retinues of worlds and myriads of intelligent beings were not irradiated and cheered by their benign influence.

\* Isaiah xlv, 18.

These thousand stars, then, which the unassisted eye can perceive in the canopy of heaven, may be considered as connected with at least *fifty thousand worlds*; compared with the amount of whose population all the inhabitants of our globe would appear only as "the smallest dust of the balance." Here the imagination might expatiate for ages of ages in surveying this portion of the Creator's kingdom, and be lost in contemplation and wonder at the vast extent, the magnitude, the magnificence, and the immense variety of scenes, objects, and movements which would meet the view in every direction; for here we have presented to the mental eye, not only single suns and single systems, such as that to which we belong, but suns revolving around suns, and systems around systems,—systems not only double, but triple, quadruple, and multiple, all in complicated but harmonious motion, performing motions more rapid than the swiftest planets in our system, though some of them move a hundred thousand miles every hour,—finishing periods of revolution, some in 50, some in 300, and some in 1600 years. We behold suns of a blue or green luster revolving around suns of a white or a ruddy color, and both of them illuminating with contrasted colored light the same assemblage of worlds. And if the various orders of intelligences connected with these systems were unveiled, what a scene of grandeur, magnificence, variety, diversity of intellect, and of wonder and astonishment, would burst upon the view! Here we might be apt to imagine that the whole glories of the Creator's empire have been disclosed, and that we had now a prospect of universal nature in all its extent and grandeur.

But although we should have surveyed the whole of this magnificent scene, we should still find ourselves standing only on the outskirts, or the extreme verge of creation. What if all the stars which the unassisted eye can discern be only a few scattered orbs on the outskirts of a cluster immensely more numerous? What if all this scene of grandeur be only as a small lucid speck compared with the whole extent of the firmament? There is demonstrative evidence from observation that this is in reality the case. In one lucid circle in the heavens, scarcely perceptible on a cursory view of the firmament, there are twenty thousand times more stars distinguishable by the telescope than what the naked eye can discern throughout the visible canopy of heaven. The Milky Way, were it supposed to contain the same number of stars throughout its whole extent as have been observed in certain portions of it, would comprise no less than 20,191,000 stars; and as each of these stars is doubtless a sun, if we suppose only fifty planets or worlds connected with each, we shall have no less than 1,009,550,000, or more than a *thousand millions* of worlds contained within the space occupied by this lucid zone. Here an idea is presented which completely overpowers the human faculties, and at which the holdest imagination must shrink back at any attempts to form an approximate conception. A thousand millions of worlds! We may state such a fact in numbers or in words, but the brightest and most expansive human intellect must utterly fail in grasping all that is comprehended in this mighty idea; and perhaps intelligences possessed of powers far superior to those of man are inadequate to form even an approximate conception of such a stupendous scene. Yet this scene, magnificent and overpowering as it is to limited minds such as ours, is not the scene of the universe; it is only a com-

paratively insignificant speck in the map of creation, which beings at remote distances may be unable to detect in the canopy of their sky, or at most will discern it only as an obscure point in the furthest extremities of their view, as we distinguish a faint nebulous star through our best telescopes.

Ascending from the Milky Way to the still remoter regions of space, we perceive several thousands of dim specks of light which powerful telescopes resolve into immense clusters of stars. These *nebulae*, as they are called, may be considered as so many milky ways, and some of them are supposed even to "outvie our Milky Way in grandeur." Above three thousand of these nebulae have been discovered; and if only two thousand be supposed to be resolvable into starry groups, and to be as rich in stars at an average as our Milky Way, then we are presented with a scene which comprises 2000 times 20,191,000, or 40,382,000,000, that is, more than *forty thousand millions* of stars. And if we suppose, as formerly, fifty planetary globes to be connected with each, we have exhibited before us a prospect which includes 2,019,100,000,000, or two billions, nineteen thousand one hundred millions of worlds. Of such a *number* of bodies we can form no distinct conception, and much less can we form even a rude or approximate idea of the *grandeur* and *magnificence* which the whole of such a scene must display. Were we to suppose each of these bodies to pass in review before us *every minute*, it would require more than three millions, eight hundred and forty thousand years of unremitting observation before the whole could be contemplated even in this rapid manner. Were an hour's contemplation allotted to each, it would require two hundred and thirty millions, four hundred thousand years until all the series passed under review; and were we to suppose an intelligent being to remain fifty years in each world for the purpose of taking a more minute survey of its peculiar scenery and decorations, 100,955,000,000,000, or a hundred billions, nine hundred and fifty-five thousand millions of years would elapse before such a survey could be completed; a number of years which to limited minds seem to approximate to something like eternity itself.

Still, *all this countless assemblage of suns and worlds is not the universe*. Although we could range on the wings of a seraph through all this confluence of sidereal systems, it is more than probable that we should find ourselves standing only on the verge of creation, and that a boundless prospect, stretching toward infinity on every side, would still be presented to view; for we cannot suppose for a moment that the empire of Omnipotence terminates at the boundaries of human vision, even when assisted by the most powerful instruments. Other intelligences may have powers of vision capable of penetrating into space a hundred times farther than ours when assisted with all the improvements of art; but even such beings cannot be supposed to have penetrated to the uttermost boundaries of creation. Man, in future ages, by the improvements of optical instruments, may be able to penetrate much farther into the remote regions of space than he has hitherto done, and may desery myriads of objects which have hitherto remained invisible in the unexplored regions of immensity. Ever since the invention of the telescope, one discovery has followed another in almost regular succession. In proportion to the increase and activity of astronomical observers, and the improvement of the instruments of observation, the more remote spaces of creation have

been explored, and new scenes of the universe laid open to human contemplation. And who shall set boundaries to the improvements and discoveries of future and more enlightened generations? Before the invention of the telescope, it would have been foolish to have asserted that no more stars existed than those which were visible to the naked eye; and after Galileo had discovered with his first telescope hundreds of stars which were previously unknown, it would have been equally absurd to have maintained that the telescope would never be farther improved, and that no additional stars would afterward be discovered. It would be a position equally untenable to maintain, that we shall never be able to descry objects in the heavens beyond the boundaries which we have hitherto explored, since science has only lately commenced its rapid progress, and since man is little more than just *beginning* to employ his powers in such investigations.

But however extensive may be the discoveries of future ages, we may lay it down as an axiom, that neither man nor any other rank of finite beings will ever be able to penetrate to the further boundaries of creation. It would be presumptuous to suppose that a being like man,—whose stature is comprehended within the extent of two yards, who vanishes from the sight at the distance of a German mile, whose whole habitation sinks into an invisible point at the distance of Jupiter, who resides on one of the smallest class of bodies in the universe, and whose powers of vision and of intellect are so limited,—should be able to extend his views to the extreme limits of the empire of the Eternal, and to descry all the systems which are dispersed throughout the range of infinitude. It is more reasonable to believe that all that has yet been discovered of the operations of Omnipotence that lie within the boundaries of human vision, is but a very small portion of what actually exists within the limits of creation; that the two billions and nineteen thousand millions of worlds which we have assumed as the scene of the visible universe, are only as a single star to the whole visible firmament, or even as a single grain of sand to all the myriads of particles which cover the sea-shores and the bed of the ocean, when compared with what lies beyond the utmost range of mortal vision; for who can set bounds to infinitude, or to the operations of Him whose power is omnipotent, “whose ways are unsearchable,” and “whose understanding is infinite?” All that we have yet discovered of creative existence, vast and magnificent as it appears, may be only a small corner of some mightier scheme which stretches throughout the length and breadth of immensity,—of which the highest created intellect may have only a few faint glimpses, which will be gradually opening to view throughout the revolutions of eternity, and which will never be fully explored during all the periods of an interminable existence. What is seen and known of creation may be as nothing compared with what is unseen and unknown; and as the ages of eternity roll on, the empire of the Almighty may be gradually expanding in its extent, and receiving new additions to its glory and magnificence.

Hence we may conclude that there is no created being, even of the highest order of intelligences, that will ever be able to survey the whole scene of the universe. Of course, man, though destined to immortality, will never acquire a complete knowledge of the whole range of the Creator's operations, even during the endless existence which lies before him; for his faculties, however much expanded in that state, will be utterly in-

adequate to grasp a scene so boundless and august. It will be a part of his happiness that he will never be able to comprehend the universe; for at every period of his future existence he will still behold a boundless prospect stretched out before him, with new objects continually rising to view, in the contemplation of which, innumerable ages may roll away without the least apprehension of ever arriving at the termination of the scene. Were a superior intelligence ever to arrive at such a point, from that moment his happiness would be diminished, his intellectual powers would lose their energy, his love and adorations of the Supreme would wax faint and languid, and he would feel as if nothing new and transporting were to be added to his enjoyments throughout all the periods of his future existence. But the immensity of the universe, and the boundless nature of the dominions of “the King Eternal,” will forever prevent any such effects from being produced in the case of all virtuous and holy intelligences.

Beside the numerous bodies to which we have above alluded, there are several other objects which require to be contemplated, in order to amplify our views of the visible universe. Those nebulous specks in the remote regions of the heavens termed *planetary nebulae* have never yet been resolved into stars, and are in all probability bodies of a different nature from the Milky Way and other sidereal systems. Their magnitude is astonishing, since some of them would fill a cubical space equal to the diameter of the orbit of Uranus, which would contain 24,000,000,000,000,000,000,000,000, or twenty-four thousand quadrillions of solid miles; that is, they are sixty-eight thousand millions of times larger than the sun. Such bodies present to our view *magnitudes* more astonishing than any others to be found within the range of the visible creation, and overwhelm the mind with wonder and amazement at what can possibly be their nature and destination. Several other nebulae are no less wonderful, such as that in the constellation of Orion which even surpasses in magnitude the dimensions now stated. It has been computed to be 2,200,000,000,000,000,000, or two trillions, two hundred thousand billions of times larger than the sun,—a magnitude which we can scarcely suppose within the power of any finite being to grasp or to comprehend. For what end such huge masses of matter were created must remain a mystery to mortals so long as they are confined to this sublunary scene. Perhaps they are intended to give us a glimpse of objects and arrangements in the Divine economy altogether different from those we perceive in the planetary system, and in the other parts of the sidereal heavens. But whatever may be their ultimate destination, we may rest assured that they serve a purpose in the plan of the Divine administration worthy of their magnitude, and of the perfections of Him by whom they were created. They were brought into existence by the same power which reared the other parts of creation; and as power is always accompanied with wisdom and goodness, they must have an ultimate reference to the accommodation and happiness of rational beings, under an economy, perhaps, widely different from that of the planetary and other systems.

Having taken a cursory view of the magnitudes of the numberless bodies scattered through the regions of space, let us now consider the *motions* which are incessantly going forward in every part of the universe; for all the myriads of globes and systems to which we have alluded are in rapid

and perpetual motion; and we have no reason to believe that there is a single quiescent body throughout the immensity of creation. We have here planets revolving around suns, planets revolving around planets, suns performing their revolutions around suns, suns revolving around the centers of sidereal systems, and, in all probability, every system of creation revolving round the center and *Grand Mover* of the whole. The rate of these motions, in every known instance, is not less than several thousands of miles every hour, and in many instances, thousands of miles in a minute. The motions which are found among the planetary globes appear, at first view, altogether astonishing, and almost to exceed belief, when we consider the enormous size of some of these bodies. That a globe a thousand times larger than our world should fly at the rate of thirty thousand miles an hour, and carry along with it a retinue of other mighty globes in its swift career, is an object that may well strike us with wonder and amazement. But the fixed stars—though to a common observer they appear exactly in the same positions with regard to each other—are found, in some instances, to be carried forward with motions far more rapid than even the bodies of the planetary system, though their magnitude is immensely superior. We have already seen that the star 61 Cygni, whose apparent motion is five seconds annually, and consequently imperceptible to a common observer, yet at the distance at which the star is known to be placed, this motion is equivalent to one thousand five hundred and fifty-two millions of miles in a year; four millions, two hundred and fifty-two thousand miles a day, and one hundred and seventy-seven thousand miles an hour. Other stars are found to move with velocities nearly similar, as  $\mu$  Cassiopeia, which moves above three millions of miles a day, which is at the rate of two thousand one hundred and sixty miles every minute. These are motions altogether incomprehensible by human beings, especially when we take into consideration the enormous magnitude of the stars, some of which may be a thousand times larger than all the planets and comets belonging to our system. They display the amazing and uncontrollable energies of OMNIPOTENCE, and afford a distinct source of admiration and astonishment in addition to all the other wonders of the universe. If, then, we would endeavor to attain a comprehensive idea of the motions going forward throughout the spaces of immensity, we must not only conceive of planets revolving around luminous centers, but of suns revolving around suns,—of suns and systems revolving around the centers of the nebulae to which they respectively belong,—of all the systems and nebulae of the universe revolving in immense circumferences around the throne of the Eternal, the great center of all worlds and beings,—of each sun, and planet, and system, notwithstanding, pursuing a course of its own in different directions, and in numerous instances acted upon by different forces,—in short, of the ten thousand times ten thousands of luminous and opaque globes, of every rank and order, within the circuit of creation,—all performing their rapid but harmonious motions throughout every region of space, and without intermission, in obedience to the laws of their Creator.

Again, we cannot be supposed to have attained a comprehensive conception of the universe, without taking into account the sensitive and intellectual beings with which it is replenished. We ought never to consider the numerous orbs revol-

ving throughout infinite space as mere masses of rude matter, arranged into systems merely to give a display of Almighty Power, but as means for accomplishing a higher and nobler end,—the diffusion of happiness among countless orders of intelligent existence. And as this idea must necessarily be admitted, what a *countless* multitude of percipient beings must people the amplitudes of creation! On our globe there are supported at least 800 millions of human beings; but it is capable of supporting twenty times that number, or sixteen thousand millions, if all its desolate wastes were cultivated and peopled. Beside man, there are numerous orders of other sensitive beings; there are at least 500 species of quadrupeds, 4000 species of bird, 5000 species of fish, 700 species of reptiles, 50,000 species of insects, beside thousands which the microscope alone can enable us to perceive—at least sixty thousand species in all. If every species contain about 500 millions of individuals, then there will be no less than 50,000,000,000,000, or thirty billions of individuals belonging to all the different classes of sensitive existence on the surface of our globe.

If this earth, then, which ranks among the smaller globes of our system, contain such an immense number of living beings, what must be the number of sentient and intellectual existence in all the worlds to which we have alluded! We assumed, on certain data, that 2,019,100,000,000, or two billions of worlds, may exist within the bounds of the visible universe; and, although no more beings should exist in each world, at an average, than on our globe, there would be the following number of living inhabitants in these worlds, 60,573,000,000,000,000,000,000,000; that is, sixty quadrillions, five hundred and seventy-three thousand trillions, a number which transcends human conception. Among such a number of beings, what a variety of orders may exist, from the archangel and the seraph to the worm and the microscopic animalculum! What a diversity of ranks in the intellectual scale, from the point of the human faculties to the highest order of created beings, may be found throughout this immensity of existence! Some, perhaps, invested with faculties as far surpassing those of man as man surpasses in intellectual energy the worm of the dust, and still approximating nearer and nearer to the Deity. What a variety may exist among them in the form, organization, senses, and the movements of their corporeal vehicles! What a wonderful and interesting scene would their history disclose, were the whole series of events in the Divine administration toward them laid open to our view!—the different periods in duration at which they were brought into existence; the special laws of social and moral order peculiar to each class of intelligences; the modes of improving the intellect, and the progress they have made in universal knowledge; the scenes of glory or of terror through which any particular classes of beings might have passed; the changes and revolutions that may await them; and the final destination to which they are appointed. These and numerous other circumstances connected with the moral and intellectual universe open to view a source of knowledge, and a subject of sublime investigation, which superior intellects might prosecute without intermission, with increasing admiration and rapture, and never arrive at the termination of their pursuits during all the periods of an endless existence.

Such is a summary view of the universe, in so far as its scenes lie open to our knowledge and investigation. The idea it presents is altogether

overpowering to the human faculties, but it is nothing else than what we should naturally expect, when we consider that the Being who formed it is self-existent and eternal; possessed of infinite wisdom, almighty power, and boundless goodness; and fills the infinity of space with his presence. It is like himself, boundless, and incomprehensible by finite minds; but exhibits to every order of intelligent beings a *sensible display* of "His Eternal Power and Godhead." Without the existence of such a universe, the infinite attributes of the Almighty could not be fully recognized and appreciated by his intelligent offspring. But here we behold, as in a mirror, the invisible perfections of the Divinity, "whom no man hath seen or can see," adumbrated, as it were, and rendered visible, in every part of creation, to the eyes of unnumbered intelligences; for there is no point of space in which a rational being could be placed, in which he would not find himself surrounded, with sensible evidences and displays of the operations of an all-wise, an all-powerful, and incomprehensible Deity. "He has not left himself without a witness" to his existence, and his incessant energies, in any parts of his dominions, or to any order of his creatures, wherever existing. "If we should ascend to heaven he is there." If we should descend to the lower regions, he is there also to be seen in his operations.—If we take the wings of the morning," and fly along with the sun from east to west, and continue our course without intermission through regions of space invisible to mortal eye, "even there his hand would lead us, and his right hand uphold us." "Darkness," unfolds the grandeur of his operations and the glories of his nature, as well as the "light" of the orb of day. Though, on the wings of a seraph we could fly in every direction through boundless space, we should everywhere find ourselves encompassed with his immensity, and with the manifestations of his presence and agency. Of such a Being, and of the universe he has formed, we may exclaim in the language of an inspired writer—"O the depth of the riches both of the wisdom and of the knowledge of God! How unsearchable are his operations, and his ways past finding out!"

Of this universe we can only form an approximate idea by comparing one small portion of it with another, and by allowing the mind to dwell for a considerable time on every scene we contemplate. We must first endeavor to acquire a comprehensive conception of the magnitude of the globe on which we dwell, and the numerous diversity of objects it contains; we must next stretch our view to some of the planetary globes, which are a thousand times greater in magnitude; and to such an orb as the sun, which fills a space thirteen hundred thousand times more expansive. Ranging through the whole of the planetary system, we must fix our attention on every particular scene and object, imagine ourselves traversing the hills, and plains, and immense regions of Jupiter, and surveying the expansive rings of Saturn in all their vast dimensions and rapid motions, until we have obtained the most ample idea which the mind can possibly grasp of the extent and grandeur of the planetary system. Leaving this vast system, and proceeding through boundless space until all its planets have entirely disappeared, and its sun has dwindled to the size of a small twinkling star, we must next survey the thousand stars that deck the visible firmament, every one of which must be considered as a sun, accompanied with a system of planets no less spacious and august than ours. Continuing our course

through depths of space immeasurable by human art, we must penetrate into the center of the Milky Way, where we are surrounded by suns, not only in thousands, but in *millions*. Here the imagination must be left for a length of time, to expatiate in this amazing and magnificent scene, and try if it can form any faint idea of twenty millions of suns, surrounded with a thousand millions of planets. Suppose one of these bodies to pass before the eye or the imagination every minute, it would require 1900 years before the whole could pass in review, and each produce a distinct impression as a separate object.

In a scene like this, the boldest imagination is overpowered and bewildered, amidst number and magnitude, and feels utterly incompetent to grasp the ten thousandth part of the overwhelming idea presented before it. Winging our flight from the Milky Way, over unknown and immeasurable regions, regions where infinitude appears opening upon us in awful grandeur, we approach some of those immense starry clusters called NEBULÆ, every one of which may be considered as another milky way, with its ten thousands and millions of suns. Here the imagination must make a solemn pause, and take a wider stretch, and summon up all its powers, and force, and vigor; for here we have not merely *one* milky way, with its millions of stars, to contemplate, but *thousands*. If the immense splendor and amplitude of one milky way overwhelms us with amazement, and with an emotion almost approaching to terror, what an overpowering effect should two thousand of such scenes, which have already been discovered, produce upon minds so feeble and limited as ours! Such a scene not only displays to us, beyond every other, the incomprehensible *energies of Omnipotence*, but seems to intimate that there are created beings existing in the universe, endowed with powers of intelligence capable of forming a much more approximate idea of such objects than beings such as man, who may be considered as standing near the lowest point of the scale of intellectual existence. These "thrones and dominions, principalities and powers of Heaven," may be able to form a comprehensive conception of such a scene as the Milky Way, which baffles the utmost efforts of the human faculties.

Soaring beyond all these objects, we behold, as it were, a new universe in the immense magnitude of the planetary and other nebulae, where separate stars have never been perceived; and beside all these, there may be thousands and ten thousands, and millions of opaque globes of prodigious size, existing throughout every region of the universe, and even in that portion of it which is within the limits of our inspection, the faintness of whose light prevents it from ever reaching our eyes. But, far beyond all such objects as those we have been contemplating, a boundless region exists, of which no human eye has yet caught a glimpse, and which no finite intelligence has ever explored. What scenes of power, of goodness, of grandeur, and magnificence, may be displayed within this unapproachable and infinite expanse, neither men nor angels can describe nor form the most rude conception. But we may rest assured that it is not an empty void; but displays the attributes of the Deity in a manner no less admirable and glorious, and perhaps much more so, than all the scenes of creation within the range of our vision. Here, undoubtedly, is that splendid region so frequently alluded to in the Scriptures, designated by the emphatic name, "THE HEAVEN OF HEAVENS," evidently importing that it is the most glorious and magnificent

department of creation. Countless myriads of beings, standing at the highest point of the scale of intellect, and invested with faculties of which we have no conception, must inhabit those regions; for we are positively informed that "hosts of intelligent beings reside in such abodes, and that "these hosts of the heaven of heavens worship God." But here our contemplations must terminate. Here imagination must drop its wings, since it can penetrate no further into the dominions of Him who sits on the throne of immensity. Overwhelmed with a view of the magnificence of the universe, and of the perfections of its Almighty Author, we can only fall prostrate in deep humility and adoration, and exclaim, "Great and marvellous are thy works, Lord God Almighty! Thou art worthy to receive glory, and honor, and power; for thou hast created all worlds, and for thy pleasure they are and were created."

I shall conclude this subject with the following remarks:

1. All the vast systems to which we have alluded are the workmanship of an Infinite and Eternal Being, and display the grandeur of his perfections. It is impossible that such an amazing universe, arranged with such exquisite order, and all the bodies it contains moving with such regular and rapid motions, could have formed itself, or been produced by the fortuitous concourse of atoms. The very surmise that such a thing was possible is one of the wildest hallucinations that ever entered the human mind. It is a first principle connected with the constitution of every intellectual nature, and without the admission of which there can be no reasoning, that there is "a connection between cause and effect," and that "every effect must have a corresponding cause adequate to its production." The universe is an *effect*, the most sublime and glorious which the human mind can contemplate, and the natural and *necessary* conclusion which it almost instinctively draws is, that it is the production of an Eternal, Intelligent, and Almighty Being. This is a conclusion which has been deduced by men of all nations, and in every period of the world. "There is no nation or people," says Cicero, "so barbarous and ignorant as not to acknowledge a powerful and Supreme Divinity."

It is as natural for the human understanding, in its original and unbiased state, when contemplating the frame of the universe, to infer the existence of a Deity, as it is the property of the eye to distinguish light and colors, and of the ear to distinguish sounds. The principle from which this conclusion is deduced is exactly the same as that by which, from the contemplation of a building, we infer a builder, and from the elegance and utility of every part of the structure, we conclude that he was a wise and skillful architect; or that by which, from an inspection of a clock or watch, or any other piece of useful machinery, we infer not only the existence, but the qualities and attributes, of the contriver and artificer. The man who is incapable of at once deducing such conclusions ought to be regarded as destitute of the reasoning faculty; and if we thus necessarily infer the cause from the effect in the case of human art, can we for a moment hesitate to ascribe the production of this amazing universe which surrounds us, to a Being of infinite knowledge, wisdom, and power, adequate to bring into existence such an immense and wonderful machine, and to preserve it in harmony, from age to age, amidst all its diversified and complicated movements? That ever a doubt was entertained on this subject is a plain proof that man has lost, in part, that

light of reason and intelligence with which he was originally indued, or that he is sometimes urged on by depraved passions and a pride of singularity to utter sentiments which he does not sincerely believe. As Cicero long ago declared—"He who thinks that the admirable order of the celestial orbs, and their constancy and regularity, on which the conservation and good of all things depend, to be void of a mind that governs them, he himself deserves to be accounted void of a mind." It is "the fool" alone, in the strictest sense of the word, whatever may be his pretended learning, who dares to declare "there is no God."

And as the universe demonstrates the *existence*, so it displays the *attributes* of the Eternal. The manifestation of himself to numberless orders of intelligent beings must have been the great end intended in bringing the universe into existence. This manifestation is made chiefly in *actions*—in actions which display greatness, wisdom, and goodness, beyond all bounds. His greatness appears from the immensity of *power* which the universe exhibits. The power necessary to move a single planet in its course far transcends human conception. What, then, must be the energy and extent of that power which set in motion and still upholds all the planets, worlds, and systems dispersed throughout the spaces of infinitude! The highest created intelligence must be utterly overwhelmed and confounded when it attempts to contemplate or to grasp an idea of Omnipotence. His knowledge, wisdom, and unceasing agency are no less conspicuous in the arrangement and direction of everything that exists in heaven and on earth. As his presence pervades all space, so his agency is displayed in the minutest movement of every part of the vast whole. This great and incomprehensible Being moves every atom, expands every leaf of the forest, decks every flower, conveys the sap through the ramifications of every tree, conducts every particle of vapor to its appointed place, directs every ray of light from the sun and stars, every breath of wind, every flash of lightning, every movement of the meanest worm, and every motion of the smallest microscopic animalculum; while at the same time he supports the planets in their courses, guides the comet in its eccentric career, regulates the movements of millions of resplendent systems, and presides in sovereign authority over unnumbered hosts of intelligent existence; directing all the mysterious powers of knowledge, virtue, and moral action to subserve the purposes of his will, and accomplish the ends of his moral government. In every department of this universe, likewise, his *goodness* is displayed to unnumbered orders of beings, sentient and intellectual; for all the powers of intelligence and action possessed by every creature in heaven and on earth, from the archangel to the worm, and all the happiness they now or ever will enjoy, are derived from him as the uncreated source of all felicity.

Under this glorious and stupendous Being we live and move; our comforts and enjoyments, while passing through this transitory scene, are wholly in his hands, and all our prospects and enjoyment beyond the range of our earthly career are dependent on his mercy and favor. His omnipotent arm supports us every moment; every breath we draw, every pulse that beats within us, every muscular power we exert, every sound that strikes our ears, and every ray of light that enters our eye-balls is dependent on his sovereign will. All that we hope for beyond the limits of time and throughout the revolution of eternity depends upon his power, his wisdom, his benevolence and

his promises. Were he to withhold the powers and agencies under which we now live and act, we could neither think nor speak, hear nor see, feel nor move; the whole assemblage of living beings in our world would be changed into immovable statues, and this earth transformed into a barren waste and an eternal solitude. To the service of this glorious Being all the powers and faculties with which he has endowed us ought to be unreservedly consecrated. As his highest glory and blessedness consist in bestowing benefits on his intelligent offspring, so we ought to be imitators of him in his boundless beneficence, by endeavoring to communicate happiness to all around us. "To do good, and to communicate, forget not; for with such sacrifices God is well pleased." To him, as the "Father of our spirits and the former of our bodies," is due the highest degree of our love and gratitude; on him we ought to rely for every blessing, and humbly resign ourselves to his disposal under every event; for "all things are of God," and all are conducted with supreme and unerring wisdom and goodness to an end immortal and divine.

2. The immensity and magnificence of the universe and the attributes of Deity it displays are considerations which ought to be taken into account in all our views of religion. There is a class of men who, in prosecuting scientific pursuits, wish to discard everything that has a bearing on religion when deduced from the investigations of science, and can scarcely refrain from a sneer, when the arrangements in the economy of nature are traced to the agency of their All-wise and Omnipotent Creator; as if the objects which science professes to investigate had no relation to the views we ought to entertain of the Divinity, and ought never to be traced to their great first cause. On the other hand, there are many professed religionists who, from mistaken notions of piety, would set aside the study of the works of God, as having no connection whatever with the exercises of piety and the business of religion, and as even injurious to their interests. Both these classes of men verge toward extremes which are equally inconsistent and dangerous. The amazing fact, that creation consists of a countless number of magnificent systems and worlds beyond the comprehension of finite minds, ought not thus to be recklessly set aside in our views of God and of religion; for they are all the workmanship of ONE BEING, and they are connected together as parts of one grand system, of which the God we profess to worship is the supreme and universal governor. They present to the view of all intelligences the most glorious displays of his character and perfections, and consequently demand from us a corresponding sentiment of admiration and reverence, and a corresponding tribute of homage and adoration. Such enlarged prospects of the universe are therefore available for the loftiest purposes of religion and piety, and ought to enter as an element into all our views of the administration of the Almighty, and of that worship and obedience he requires from his rational offspring, unless we would be contented to render him a degree of homage far inferior to that which the manifestation of his attributes demands.

God is known only by the manifestations which he makes of his character and perfections. The highest created intelligences can know nothing more of the Divinity than what is derived from the boundless universe he has presented to their view, the dispensations of his providence to certain orders of beings, and the special revelations,

he may occasionally vouchsafe, on certain emergencies, to particular worlds. Had man continued in primeval innocence, the contemplation of the vast creation around him, with all its diversified wonders and beneficent tendencies, would have led him to form correct views of the attributes of his Almighty Maker, and of the moral laws by which his conduct should be regulated; but it does not follow, that because the study of nature is now of itself an insufficient guide to the knowledge of the Creator and the enjoyment of eternal felicity, such studies are either to be thrown aside, or considered as of no importance in a religious point of view. To overlook the astonishing scene of the universe, or to view it with indifference, is virtually to "disregard the works of Jehovah, and to refuse to consider the operations of his hands." It is a violation of Christian duty, and implies a reflection on the character of the Deity, for any one to imagine that he has nothing to do with God considered as manifested in the immensity of his works; for his word is pointed and explicit in directing the mind to such contemplations. "Hearken unto this; stand still, and consider the wonderful works of God." "Lift up thine eyes on high, and behold who hath created these orbs." "Remember that thou magnify his works which men behold." "Great and marvelous are thy works, Lord God Almighty! Thy saints shall speak of the glory of thy kingdom and talk of thy power, to make known to the sons of men thy mighty operations and the glorious majesty of thy kingdom."

3. The Christian revelation, throughout all its departments, is not only consistent with the views we have taken of the universe, but affords direct evidence of the magnificence of creation, and of the myriads of beings with which it is peopled. Of this position we have exhibited some proofs in the remarks and illustrations contained in Chapter XVII, which show at the same time the harmony which subsists between the discoveries of revelation and the discoveries which have been made in the system of nature. There is no other system of religion or pretended revelation that was ever propagated in the world to which such a characteristic belongs. If we examine the Mahomedan Koran, the Shasters of Bramah, the system of Confucius, the mythology of the Greeks and Romans, and every other Pagan code of religion, we shall find interspersed throughout the whole of them numerous sentiments, opinions, and pretended facts at utter variance with the true system of nature, and to what are known to be the established laws of the universe. This is strikingly exemplified in the extravagant stories and descriptions contained in the pretended revelations of Mahomet, and the absurd notions respecting the creation contained in the sacred books of the Hindoos, which assert that the universe consists of seven heavens and seven worlds, which are all at a future period to be absorbed into God; with many other absurdities. In opposition to all such foolish and absurd opinions, the inspired writings, when properly understood, and rationally interpreted according to the rules of just criticism, are uniformly found to be perfectly consistent with the discoveries of science, and the facts which are found to exist in the system of the universe; and this correspondence and harmony ought to be considered as a strong presumptive evidence that the revelations of Scripture and the scenes of the material universe proceed from the same All-wise and Omnipotent Author.

## CHAPTER XX.

### ON COMETS.

As this class of the celestial bodies forms a part of the solar system, it might have been more appropriate to have introduced the subject into our volume entitled, "Celestial Scenery," which has for its principal object a description of the bodies connected with that system; but as that work swelled to a greater size than was at first foreseen, it was judged expedient to postpone the consideration of comets to the present volume. As our knowledge of these bodies, however, is very limited, and no discoveries have yet been made which might lead us to form a decisive opinion of their nature and destination, I shall content myself with giving a brief detail of some of the leading facts which have been ascertained respecting them.

The word *comet* literally signifies a *hairy star*; because such bodies are generally accompanied with a nebulosity, or train, which has the appearance of luminous hair. The luminous point near the center of a comet, which is the most brilliant, is called the *nucleus*. The haze or nebulosity which surrounds the nucleus is called the hair, and sometimes the *envelope*; and the nucleus and hair combined constitute what is usually termed the *head* of the comet. The luminous train, extending sometimes to a great distance from the head, is called the *tail* of the comet. These bodies have occasionally appeared in the heavens in all ages. The ancients were divided in their opinion respecting them; some considering them as wandering stars; others, as meteors kindled in the atmosphere of the earth, subsisting for a time, and then dissipated; and others viewed them as prodigies indicating wars, famines, inundations, or pestilences. Aristotle, who believed that the heavens were incorruptible and unchangeable, maintained that comets were generated when they first made their appearance, and were destroyed when they ceased to be visible, and consequently that they could not be reckoned to belong to the heavenly bodies, but were only meteors or exhalations raised into the upper regions of the air, where they blazed for awhile, and disappeared when the matter of which they were formed was consumed. And as the opinions of this ancient sage had a powerful influence on the philosophers and astronomers of later times,—as his assertions were frequently regarded as little short of demonstrations,—few persons had the boldness and independency of mind to call in question the positions he maintained on any subject discussed in his writings.

It was not before the time of the celebrated astronomer, Tycho Brahe, that the nature of comets began to be a little understood, and that they were considered as moving in the planetary regions. This astronomer observed with great diligence the famous comet which appeared in 1577; and from many accurate observations during the time of its appearance, found that it had no sensible diurnal parallax, and therefore was not only far above the limits of our atmosphere, but beyond the or-

bit of the moon itself. Its motions were likewise particularly observed by Hagecius, at Prague, in Bohemia, at the same time that they were observed by Tycho, at Uraniburg. These two places differ six degrees in latitude, and are nearly under the same meridian, and both measured the distance of the comet from the same star, which was in the same vertical circle with the comet; yet both observers found their distances the same, and consequently they both viewed the comet in the same point of the heavens, which could not have happened unless the comet had been in a higher region than the moon. After Tycho, Kepler had an opportunity of making observations on the comets which appeared in 1607 and 1618, and from all his observations he deduced this conclusion, "that comets move freely through the planetary orbs." From this period comets began to be more accurately observed, and to be considered as constituent parts of the solar system; and at length the illustrious Newton demonstrated that their motions are performed in long ellipses, having the sun in one of their foci.

Before proceeding to inquire into the nature and physical constitution of these bodies, I shall present the reader with

#### A BRIEF SKETCH OF THE HISTORY OF THE MOST REMARKABLE COMETS WHICH HAVE APPEARED IN MODERN TIMES.

One of the most remarkable comets which appeared in modern times is that which made its appearance toward the close of the year 1680, and which was particularly observed by most of the astronomers of Europe. This comet, according to the accounts given by the astronomers of that period, appeared to descend from the distant regions of space with a prodigious velocity, almost perpendicular to the sun, and ascended again in the same manner from that luminary with a velocity retarded as it had before been accelerated. It was observed, particularly at Paris and Greenwich, by Cassini and Flamsteed, by whom it was seen in the morning from the 4th to the 25th of November, 1680, in its descent toward the sun; and after it had passed its *perihelion*,\* in the evening, from the 12th of December to the 9th of March, 1681. The many exact observations made on this comet enabled Sir I. Newton to discover that so much of its orbit as could be traced by the motion of the comet, while it was visible, was, as to sense, a *parabola*, having the sun in its focus, and that it was one and the same comet that was seen all that time. This comet was remarkable for its very near approach to the sun. At its perihelion, it was not above a sixth part of the sun's diameter from its surface; that is, about

\* The *perihelion* is that point in the orbit of any planet or comet which is nearest to the sun. It is also called the *lower apsis*. The *aphelion* is that point in the orbit which is farthest from the sun; called, also, the *higher apsis*.



146,000 miles from the surface of that luminary, and 584,000 from its center. According to Sir Isaac Newton, the velocity of this comet when nearest the sun, was 880,000 miles an hour. On taking its perihelion distance, as given by M. Pingre, Mr. Squire found, by two different calculations, that its velocity in its perihelion was no less than 1,240,000 miles an hour! This velocity was so great that, if continued, it would have carried it through 124 degrees in an hour; but its actual hourly motion during that interval, before and after it passed the perihelion, was 81 degrees, 47 minutes. At this period, the diameter of the sun, as seen from the comet, must have subtended an angle of more than a hundred degrees, which must nearly have filled its whole hemisphere.

From Dr. Halley's determination of its orbit, it appears that when in its aphelion, or greatest distance from the sun, it cannot be less than 13,000,000,000, or thirteen thousand millions of miles distant from that luminary; that is, seven times the distance of Uranus. According to the same astronomer, this comet, in passing through its southern node, came within the length of the sun's semidiameter of the orbit of the earth, that is, within 440,000 miles; and he remarks, "had the earth been then in that part of its orbit nearest that node of the comet, their mutual gravitation must have caused a change in the plane of the earth's orbit, and in the length of our year; and if so large a body with so rapid a motion were to strike the earth, a thing by no means impossible, the shock might reduce this beautiful frame to its original chaos." Modern observations, however, render such deductions somewhat improbable. The period of this comet is supposed to be about 575 years. It is conjectured that it is the same comet which appeared in 1106, in the reign of Henry I, that was seen during the consulate of Lampadius and Orestes, about the year 531, and in the forty-fourth year before Christ, in which year Julius Cæsar was murdered. Its nucleus was computed to be about ten times as large as the moon. Its tail extended over a space of seventy degrees in extent.

This is the comet, to the near approach of which to the earth, Mr. Whiston attributed the universal deluge in the time of Noah. His opinion was, that the earth, passing through the atmosphere of the comet, attracted from it a great part of the water of the flood; that the nearness of the comet raised a great tide in the subterranean waters; that this could not be done without making fissures or cracks in the outer crust of the earth; that through these fissures the subterranean waters were forced; that along with the water much slime or mud would rise, which, after the subsiding of the water partly into the fissures and partly into the lower parts of the earth to form the sea, would cover over to a considerable depth the antediluvian earth; and thus he accounts for trees and bones of animals being found at very great depths in the earth. The same comet, he supposed, when coming near the earth after being heated to an immense degree in its perihelion, would be the instrumental cause of that great catastrophe, the general conflagration. Modern geological researches, however, render all such hypotheses utterly untenable.

2. Another comet which has obtained a certain degree of celebrity is that which appeared in 1682, and is usually distinguished by the name of *Halley's comet*. This comet appeared with considerable splendor, and exhibited a tail thirty degrees in length. On calculating its elements from its perihelion passage, Dr. Halley was led to

conclude that it was identical with the great comets which appeared in 1456, 1531, and 1607, whose elements he had also ascertained. The intervals between these periods being about seventy-five or seventy-six years, he was led to conclude that this was the period of the revolution of the comet, and ventured to predict that it would again return about the latter part of the year 1758. As this was the first comet whose return had been predicted, when the time of its expected appearance approached, astronomers became anxious to ascertain whether the attraction of the larger planets, Jupiter and Saturn, might not interfere with its orbital motion, and prevent it from arriving at its perihelion as soon as the time predicted. Clairaut, an eminent French mathematician, after many intricate and laborious calculations in reference to the subject, concluded that the attraction of Saturn would lengthen the period 100 days, and the action of Jupiter 518, making in all 618 days, by which the expected return would happen later than if no such influence had taken place; so that instead of the period being 74 years, 323 days, it ought to be 76 years, 211 days; and as the comet passed its perihelion on September 14, 1682, it ought to reach the same point on April 13, 1759. These calculations were read before the Academy of Sciences, on the 14th of November, 1758; but Clairaut gave notice that, being pressed for time, he had neglected in his calculations small values, which collectively might amount to about thirty days, in the seventy-six years. These predictions were accordingly verified, for the comet appeared about the end of December, 1758, and arrived at its perihelion on the 13th of March, 1759, only thirty days before the time fixed by the calculations of Clairaut, who, upon repeating the process by which he had arrived at the result, reduced this error to nineteen days. The same comet again made its appearance, according to prediction, in 1835, of which a particular account will be given in the sequel.

3. Another remarkable comet made its appearance in 1744, which excited a considerable degree of attention. It was first seen at Lausanne, in Switzerland, December 13, 1743; from that period it increased in brightness and magnitude as it approached nearer the sun. On the evening of January 23, 1744, it appeared exceedingly bright and distinct, and the diameter of its nucleus was nearly equal to that of Jupiter. Its tail then extended above 16 degrees from its body, and was supposed to be about 23 millions of miles in length. On the 11th of February, the nucleus, which had before been always round, appeared oblong in the direction of the tail, and seemed divided into two parts by a black stroke in the middle. One of the parts had a sort of beard, brighter than the tail; this beard was surrounded by two unequal dark strokes, that separated the beard from the hair of the comet; these odd phenomena disappeared the next day, and nothing was seen but irregular obscure spaces like smoke in the middle of the tail, and the head resumed its natural form. On the fifteenth of February, the tail was divided into two branches, the eastern about 8 degrees long, the western 24. On the 23d the tail began to be bent. It showed no tail until it was as near the sun as the orbit of Mars, and it increased in length as it approached nearer that luminary. At its greatest length, it was computed to equal a third part of the distance of the earth from the sun.\* This was one of the most brilliant comets that had appeared since that

\* Memoirs of the Academy of Sciences for 1744.

of 1680. Its tail was visible for a long time after its body was hid under the horizon: it extended 20 or 30 degrees above the horizon, two hours before sunrise.

4. In the month of June, 1770, Messier discovered a comet, the motions of which appear to be involved in a considerable degree of mystery.—The comet continued visible for a long time.—Lexell ascertained, from observation, that it described an ellipse around the sun, of which the greater axis was only three times the diameter of the earth's orbit, which corresponds with a revolution of  $5\frac{1}{2}$  years. It was therefore expected that it would again frequently make its appearance; but it has never since been visible, although it made a pretty brilliant appearance in 1770.—The National Institute of France, not many years ago, requested M. Burkhart to repeat all the calculations with the utmost care; and the result of his labor has been a complete confirmation of the elements obtained by Lexell. What has become of this comet it is difficult to conjecture. Its aphelion, or greatest distance from the sun, was reckoned to be not far beyond the orbit of Jupiter, and that it approached as near to the earth as the moon, and ought to have appeared twelve times since the year 1770. M. Arago attempts to solve the difficulty by affirming that its orbit was then totally different from that which it has since pursued; that its passage to the point of perihelion in 1776, when it was expected, took place by day, and before the following return, the form of the orbit was so altered that had the comet been visible from the earth, it would not have been recognized; that before 1777, during the whole progress of its revolutions, its shortest distance from the sun was 199,000,000 leagues, and that after 1779, the minimum distance became 131,000,000 leagues, which was still too far removed for the comet to be perceptible from the earth. Sir David Brewster attempts to account for its disappearance by supposing that it must have been attracted by one of the planets whose orbit it crossed, and must have imparted to it its nebulous mass; and that it is probable the comet passed near Ceres and Pallas, and imparted to them those immense atmospheres which distinguish them from all the other planets. Whether any of these opinions be tenable and sufficient to solve the difficulty, is left entirely with the reader to determine.

5. Another comet which has engaged the particular attention of astronomers during the last twenty years, is distinguished from all preceding comets by the *shortness of its periodical revolution*. It is usually denominated *Encke's comet*, so called from Professor Encke, of Berlin, who first ascertained its periodical return. It was discovered at Marseilles, on the 26th November, 1818, by M. Pons, and its parabolic elements were presented to the Board of Longitude, at Paris, by M. Bouvard, on the 13th of January, 1819. It was immediately remarked that the result of Bouvard's calculations was too similar to the elements of a comet which appeared in 1805, not to consider that and the one of 1818 as the same body; and M. Encke soon after established, by incontestable calculations, that this comet took only about 1200 days, or three years and three-tenths, to travel through the whole extent of its elliptic orbit. This was considered as a very extraordinary result, as an opinion had previously prevailed that the period of a revolution of a comet must necessarily be long. It now appears that this comet was first seen by Messier and Mechain in 1786; afterward by Miss Herschel in 1795; and its subsequent returns were observed by different astron-

omers in 1805 and 1819, all of whom, at those periods, supposed that the four comets were four different bodies. The elements of this comet, and the short period of its revolution, are now incontrovertibly established; for its reappearance in the southern hemisphere in June, 1822, took place very nearly in the positions previously calculated. The agreement was not less remarkable in 1825; and in 1828, the third period of its announced return, it occupied the places assigned to it by Encke the year preceding. It likewise appeared in 1832, 1835, and 1838.

This comet is very small; its light is feeble; it has no tail; it is invisible to the naked eye, except in very favorable circumstances, but may be seen with a small magnifying power. It revolves in an elliptical orbit of considerable eccentricity, having an inclination to the plane of the ecliptic of  $13\frac{1}{3}$  degrees. On comparing the intervals between the successive perihelion passages of this comet, a singular fact has been elicited, namely, that its periods are continually diminishing, and its mean distance from the sun shortening by slow but regular degrees. This is supposed by M. Encke to be produced by a resistance experienced by the comet from a very rare ethereal medium pervading the regions through which it moves; since such resistance, by diminishing its actual velocity, would diminish also its centrifugal force, and thus give the sun more power over it to draw it nearer. It is therefore the opinion of Sir J. Herschel, that "it will probably fall ultimately into the sun, should it not first be dissipated altogether, a thing no way improbable, when the lightness of its materials is considered, and which seems authorized by the observed fact of its having been less and less conspicuous at each reappearance." The acceleration of this comet is about two days in each revolution; and the frequent opportunities of observation which will occur, in consequence of the shortness of its period, may lead to new and interesting conclusions in relation to the nature of these bodies.

6. Beside the above, another periodical comet has lately been discovered, which is distinguished by the name of *Biela's* and sometimes *Gambart's comet*. This comet was perceived at Johannisberg, on the 27th Feb., 1826, by M. Biela; and by M. Gambart, at Marseilles, ten days afterward. Gambart, without delay, calculated its parabolic elements from his own observations, and by inspecting a general table of comets, he recognized that it was not its first appearance, but that it had been already observed in 1789, and 1795. Messrs. Clausen and Gambart undertook the computation of the comet's revolution, and found, each of them nearly at the same time, that the new comet made its entire revolution round the sun in a period of about seven years. It was afterward found, more accurately, to be 2460 days, or nearly  $6\frac{3}{4}$  years. M. Danoiseau calculated the perturbations of this comet, and predicted that it would cross the plane of the earth's orbit on the 29th of October, 1832, *a little before midnight*, at a point about 18,480 miles within the orbit of the earth. According to this prediction, the comet actually made its appearance in 1832 about the time now specified. Its next appearance was calculated to happen in 1839; and it was reckoned that it would arrive at its perihelion on the 23d July of that year.

The predicted appearance of this comet in 1839 seems to have produced considerable alarm, particularly in France. Some German journalists predicted that it would cross the earth's orbit near the point at which the earth would be at the time, and cause the destruction of our globe. Such was

the degree of alarm excited on this occasion, that M. G\*\*\*, a Professor in Paris, put the question to the Academy of Sciences, whether it did not feel itself bound in duty to refute, as speedily as possible, this assertion. "Popular terrors," he observed, "are productive of serious consequences. Several members of the Academy may still remember the accidents and disorders which followed a similar threat, imprudently communicated to the Academy by M. de Lalande, in May, 1773. Persons of weak mind died of fright, and women miscarried. There were not wanting people who knew too well the art of turning to their advantage the alarm inspired by the approaching comet, and places in paradise were sold at a very high rate. The announcement of the comet of 1832 may produce similar effects, unless the authority of the Academy apply a prompt remedy; and this salutary intervention is at this moment implored by many benevolent persons." It was supposed by some, that if any disturbing cause should delay the arrival of the comet for one month, the earth must pass directly through its head.

In order to dispel such fears, and to illustrate the nature of these bodies, M. Arago published an excellent and popular treatise on comets in the "Annuaire" of 1832. He showed that the result of the calculation was, that the passage of the comet ought to proceed a little within our orbit, and at a distance from that curve, which is equal to four terrestrial radii and two-thirds, or about 37,000 miles; that on the 29th October, 1832, a portion of the earth's orbit might be included within the nebulosity of the comet; but that the earth would not arrive at the same point of its orbit until the morning of the 30th November, or more than a month afterward; and consequently that the earth would be more than twenty millions of French leagues (or fifty millions of British miles) distant from the comet. He adds, that "if the comet, instead of crossing the plane of the ecliptic on the 29th October, had not arrived there until the morning of the 30th November, it would have undoubtedly mingled its atmosphere with ours, and perhaps even have struck us!" The earth is considered in more danger, if danger there be, from this comet and that of Encke than from any other. Encke's comet crosses the orbit of the earth sixty times in the course of a century, and there is certainly a possibility that it might come into collision with the earth, but the probability of its doing so is very small; and, beside, this comet and that of Gambart are so extremely rare, that little danger is to be apprehended, even although a contact were to take place. Gambart's is a small, insignificant comet, without a tail, or any appearance whatever of a solid nucleus, and is not distinguishable by the naked eye.

7. *The Comet of 1807.* This was the first comet on which I had an opportunity of making observations. My first observation was on the evening of October the 8th, 1807, a little after sunset, when it appeared in a north-westerly direction, not far distant from Arcturus, which was then only a little above the horizon. To the naked eye it appeared somewhat like a dim nebulous star of the second magnitude, with a beam of light on one side of it. Through a telescope, its tail presented a pretty brilliant appearance, and occupied a space of considerably more than a degree in length. The coma seemed to have a roundish, but dim and undefined appearance, and appeared more indistinct as the magnifying power was increased. When viewed with an achromatic telescope of thirty-one inches focal distance, and a power of thirty, it presented a very distinct,

and beautiful appearance, and the nucleus, coma, and tail, nearly filled the field of view. When a power of sixty was applied, it was much more indistinct than with the former power and in all the subsequent observations the lower power was generally preferred. In the course of five or six weeks, or about the middle of November, it disappeared to the naked eye. I traced it with the telescope, as often as the weather would permit, for two or three months after it had become invisible to the unassisted sight, and found that its apparent motion was pretty rapid, and toward the north-east. About the middle of January, 1808, at eleven, P. M., it appeared in a direction north-east by north; and at this time it appeared through the telescope like a small nebulous star, or like those species of comets called bearded comets, having no trace of anything similar to a tail. The last time I saw it was about the end of January, when it was still distinctly visible, like a nebulous star; but cloudy weather for nearly a fortnight prevented any further observations, and I saw it no more. On the evening in which I had the last peep of it, I detected another comet within eight or ten degrees of it, which appeared like a star of the third magnitude, and exhibited a pretty brilliant appearance through the telescope. It had no tail, like the former comet, but appeared surrounded with radiant hairs like the glory which painters represent around the head of our Saviour. It continued visible for several weeks; but I have not seen any particular notices of this second comet, or any special observations on it, which have been recorded by astronomers.

This comet appears to have been first noticed by Herschel and Schroeter about the 4th of October, 1807, who continued their observations upon it for several months. According to Schroeter's observations and estimates, the diameter of the nucleus of this comet was about 4600 miles, or nearly the size of the planet Mars, and appeared to be of considerable density; the diameter of its coma, 120,000 miles, but liable at different times, to variations of increase and decrease; and its rate of motion, at certain periods, 1,333,380 miles a day, or 55,557 miles an hour. Its tail was divided in a very unusual manner into two separate branches; the north side continued much brighter and better defined than the other, and was also invariably convex, while the other side was concave. But what was deemed most remarkable was the variation in length and the cuscatations of the tail. Something like cuscatation had been observed by the naked eye in the case of preceding comets, and such phenomena appear to have been confirmed by the observations of Schroeter. In less than one second, streamers shot forth to two and a half degrees in length; they as rapidly disappeared and issued out again, sometimes in proportions and interrupted like our northern lights. Afterward the tail varied both in length and breadth, and in some of the observations, the streamers shot from the whole expanded end of the tail, sometimes here, and sometimes there, in an instant, two and a half degrees long, so that within a single second they must have shot out a distance of 4,600,000 miles. Their light was also sometimes whiter and clearer at the end than at the base, as is occasionally seen in the northern lights. Some have objected to the extreme rapidity of the streamers as here stated, but the fact of cuscatations having been seen appears to be confirmed by the observations of this celebrated and accurate observer. The observations of Herschel on this comet differ in some respects from those of Schroeter, particularly in the estimate he

makes of the size of the nucleus, which he reckons to be considerably smaller than what has been stated above.

Fig. 78 is a view of this comet as seen on the night of October 21st by Schroeter. Fig. 79 is a view of the same comet as seen by Bessel, October 22d, at eight in the evening; both which exhibit its divided tail.

8. The most remarkable comet which has appeared in modern times, since that of 1680, was the comet of 1811. About the beginning of Sep-

tember in that year, about eight or nine in the evening, as I was taking a random sweep with my telescope over the north-western quarter of the heavens, an uncommon object appeared to pass rapidly across the field of view, which on examination appeared to be a splendid comet. Not having heard of the appearance of any such body at that time, I was led to imagine that I had fortunately got the first peep of this illustrious stranger; but I afterward learned from the public prints that it had been seen a day or two before by Mr. Neitch, in the neighborhood of Kelso, who appears to have been the first that observed it in this country. This comet appeared with peculiar splendor, and was visible, even to the naked eye, for more than three months in succession, and excited universal attention. It afforded to astronomers more opportunities for observation

of its physical aspect and constitution, and for determining the elements of its orbit, than almost any other comet that had previously appeared. The two celebrated observers, Herschel and Schroeter, made numerous and very particular observations on the phenomena and motions of this comet, which were continued every clear evening for the space of nearly five months. Some of these observations, along with the remarks and deductions connected with them, are extremely interesting to the astronomical observer; but my limits will

permit only a statement of the general results.

Some of the results deduced by Schroeter are the following:— That the central globe of light, or what he calls the nucleus, was 50,000 miles in diameter, or nearly six and a half times the diameter of the earth, which he deduced from the mean of twenty-seven measurements, which gave  $1^{\circ} 49''$  as the mean angular diameter of the body; that this great body was in all probability chiefly fluid, though its central parts might consist of denser substances; and that there was reason to believe that it shone with its own native light. The coma was extremely rarefied in comparison with the nucleus, resembling a very faint whitish light, scattered in separate portions. It was divided into two; one immediately encompassing the nucleus, the other of a more faint and grayish light, sweeping round it at a distance, and forming the double tail which the comet presented. The train, or head rail, as he terms it, swept around the nucleus, at a distance equal to its breadth, and appeared as unconnected as the ring of Saturn with its body, and which sometimes appeared darker than the open sky. The diameter of this exterior part of the head was  $34^{\circ} 15'$ , or about 947,000 miles, which is larger than the diameter of the sun, and which he thinks must have formed a hollow cone around the nucleus, and which he thought indicated a force of a repulsive nature residing in the nucleus. Between the 4th and 6th of December a great revolution took

place; the rarefied nebulous matter, which had for three months been so unusually repelled from the nucleus on every side, to a distance of about one-fifth of the diameter of the head, or 190,000 miles, was again attracted to it, affording an incontrovertible proof of physical action upon a great scale, arising doubtless from the same causes which produce the other phenomena of nature. The double tail of this comet was exceedingly faint compared with the nucleus and coma. On the 23d of October, it extended fully eighteen degrees, notwithstanding its oblique position, the angle at the sun being then  $61^{\circ} 23'$ ; at the earth,  $69^{\circ}$ ; and at the comet,  $49^{\circ} 37'$ . Had it been viewed at right angles, it would have subtended an angle of  $36^{\circ} 36'$ , equivalent to more than 60,000,000 of miles, which is more than half the distance from the earth to the sun. *Coruscations*, similar to those

Fig. 78.

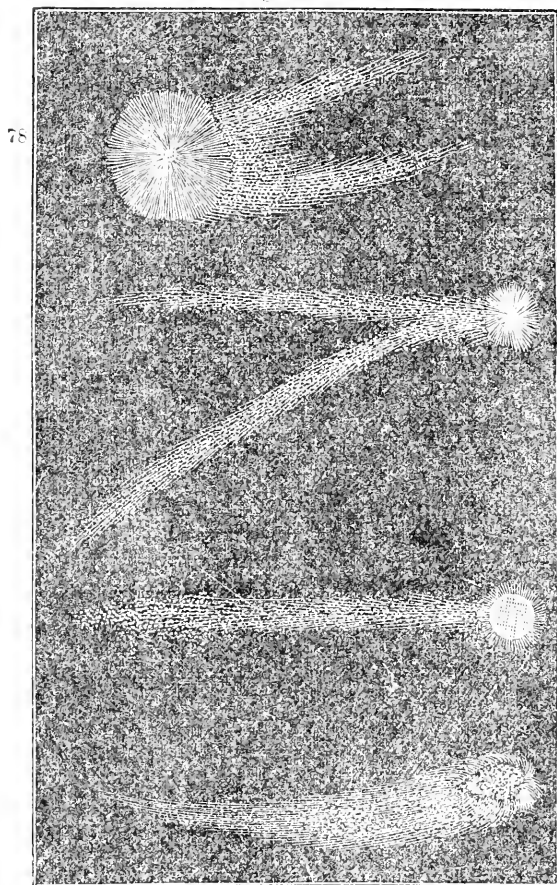

tember in that year, about eight or nine in the evening, as I was taking a random sweep with my telescope over the north-western quarter of the heavens, an uncommon object appeared to pass rapidly across the field of view, which on examination appeared to be a splendid comet. Not having heard of the appearance of any such body at that time, I was led to imagine that I had fortunately got the first peep of this illustrious stranger; but I afterward learned from the public prints that it had been seen a day or two before by Mr. Neitch, in the neighborhood of Kelso, who appears to have been the first that observed it in this country. This comet appeared with peculiar splendor, and was visible, even to the naked eye, for more than three months in succession, and excited universal attention. It afforded to astronomers more opportunities for observation

which appeared in the tail of the comet of 1807, were likewise perceived, particularly on October the 16th, when a small tail instantaneously appeared, then vanished, and reappeared, which was in length equal to three times the diameter of the comet's head, or 2,373,000 miles. Other displays of the same kind took place on the 7th of November and the 18th of December. These facts, of the reality of which Schroeter entertained not the least doubt, must be considered as very curious and extraordinary phenomena.\*

Herschel's observations nearly agree with those of Schroeter, excepting that he estimates the diameter of the nucleus as very much smaller than what is stated above. He estimates the *greatest length* of the tail, as seen on the 15th of October, to have been 100,000,000, or a hundred millions of miles, which consequently extended over a space larger than that which intervenes between the earth and the sun; and its *breadth*, as deduced from the observations of October the 12th, nearly fifteen millions of miles. He calculated its distance when nearest to the earth to be about 113 millions of miles. He concluded that the solid matter of the comet was spherical, that it shone in part by its own native light, and that it probably had a rotation round its axis. From the most accurate observations of the motion of this comet, its period of revolution has been calculated to exceed 3000 years. Bessel computes it at 3383 years; and several other astronomers conceive its period to be considerably longer, even exceeding 4000 years.

9. *Reappearance of Halley's Comet in 1835.* The return of this comet was calculated by Messrs. Damoiseau and Pontécoulant; the former of whom calculated its return to the perihelion on the 4th, and the latter on the 7th of November, 1835, and it actually arrived at that point only a few days after these periods, namely, on the 16th of November. It was first seen on the continent in the month of August that year, but does not appear

\* Having referred, on various occasions, to the observations of that indefatigable astronomer, *Schroeter*, of Lilienthal, it may not be uninteresting to some readers to insert the account of the losses he sustained by the burning and plunder of his observatory, as expressed in his own pathetic language :

"At length, after the most touching afflictions of mortality, I once more awake in my temple consecrated to the Eternal Godhead, and am again able, after a total derangement of my affairs, to edit these collections concerning the great comet of 1811. Through the most barbarous fury, in consequence of an equally barbarous decision, the whole innocent soft vale of Lilies (the signification of the name of Lilienthal, where his observatory was situated) was burnt to the ground, without any previous examination. They likewise burnt down the royal government buildings. I lost my whole movable property, and, what was most sensibly felt by me, amongst it, with a considerable loss also to the book-sellers of Europe, the sole copy of the whole of my works and writings deposited in the government house.—Even my observatory, preserved by Providence from the fire, was a few days afterward broken into, plundered, and shamefully thrown into confusion by demolishing the clocks, breaking off the finders from the instruments, and carrying off the smaller instruments. Previously, indeed, having been removed from my post, my income had gradually become so very straitened, I was obliged to forego all but the most necessary outlays, and to give myself up to a scientific slumber. Under the endurance of these troubles all my scientific patrons and friends will doubtless, as far as possible, excuse me, if through melancholy, and on account of the extraordinary high rate of postage, I have been compelled to put out of sight so many obligations of courtesy, or to the present time everything is so straitened with me that my observatory, from want of time and heavy expenses is for the most part a confusion.

"JOH. HIERONYM. SCHROETER."

"Lilienthal, Jan. 22, 1815."

Schroeter did not long survive the calamity alluded to above. He died on the 29th of August, 1816, in the 71st year of his age.

to have been noticed in the northern parts of Britain until more than a month afterward. Its expected reappearance excited universal attention throughout Europe. Soon after the middle of September, as I was taking a sweep with a two-feet telescope over the north-eastern quarter of the heavens, near the point where I expected its appearance, I happened to fix my eye on this long-expected visitor, which appeared very small and obscure. I immediately directed an excellent three and a half feet achromatic telescope, with a diagonal eye-piece, magnifying about thirty-four times, to the comet, when it was distinctly seen, and appeared of a considerable diameter, but still somewhat hazy and obscure. I afterward applied a power of forty-five, and another of ninety-five; but it was seen most distinctly with the lower power. With ninety-five it appeared extremely obscure, and nearly of the apparent size of the moon.\* There appeared at this time nothing like a tail, but the central part was much more luminous than the other portions of the comet, and presented something like the appearance of a star of the third or fourth magnitude surrounded with a haze. In some of the views I took of this object, the luminous part or nucleus appeared to be considerably nearer one side than another. At this period, and for a week or ten days afterward, the comet was altogether invisible to the naked eye. Many subsequent observations were made, and published in the provincial newspapers, out which my present limits prevent me from inserting.

After the comet became visible to the naked eye, the tail began to appear, and increased in length as it approached its perihelion, and at its utmost extent was estimated to be above thirty degrees in length. On the 13th of October, according to the observations of Arago, a luminous sector was visible in its head; on the day following, the sector had disappeared, and a more brilliant one and of greater longitudinal extent was formed in another place. This second sector was observed on the 17th, when it appeared less bright; and on the 18th its weakness had decidedly increased. The comet was concealed until the 21st, but on that day three distinct sectors were visible in the nebulosity. On the 23d, all traces of these sectors had disappeared, the nucleus, which had previously been brilliant and well-defined, having become so large and diffuse that the observer could scarcely believe in the reality of such a sudden and important alteration, until he satisfied himself that the appearance was not occasioned by the moisture on the glasses of his instrument. It appears, likewise, that one of these luminous fans or sectors was observed by Sir J. Herschel, at the Cape of Good Hope, after the comet had passed its perihelion. The nebulosity of this comet appears to have increased in magnitude as it approached the sun, but its changes were sometimes unaccountably rapid. On one occasion it was observed to become obscure and enlarged in the course of a few hours, though a little before its nucleus was clear and well-defined. On the 11th of October, the Rev. T. W. Webb, and two other observers, observed *coruscations* in the tail. On that evening, at 7h. 30', the tail was very conspicuous, extending between  $\alpha$  and  $\gamma$  Draconis, and evidently fluctuated, or rather *coruscated*, in length, being occasionally short, and then stretch-

\* In viewing comets, telescopes with large apertures and comparatively low magnifying powers should generally be used, as the faint light emitted by comets, whether it be inherent or reflected, will not permit the use of so high magnifying powers as may be applied to the planets.

ing, in the twinkling of an eye, to its full extent, which was at least equal to ten degrees. Its changes were extremely similar to the kindling and fading of a very faint streamer of the Aurora Borealis.

"The influence of the ethereal medium on the motion of Halley's comet will be known after another revolution, and future astronomers will learn, by the accuracy of its returns, whether it has met with any unknown cause of disturbance in its distant journey. Undiscovered planets beyond the visible boundary of our system may change its path and the period of its revolution, and thus may indirectly reveal to us their existence, and even their physical nature and orbit. The secrets of the yet more distant heavens may be disclosed to future generations by comets which penetrate still farther into space, such as that of 1763, which, if any faith may be placed in the computation, goes nearly 43 times farther from the sun than Halley's does, and shows that the sun's attraction is powerful enough at the distance of 141,609 millions of miles to recall the comet to its perihelion. The periods of some comets are said to be many thousand years, and even the average time of the revolution of comets generally is about a thousand years; which proves that the sun's gravitating force extends very far. La Place estimates that the solar attraction is felt throughout a sphere whose radius is a hundred millions of times greater than the distance of the earth from the sun." "The orbit of Halley's comet is four times longer than it is broad; its length is about 3420 millions of miles, about 36 times the mean distance of the earth from the sun. At its perihelion it comes within 57 millions of miles of the sun, and at its aphelion it is 60 times more distant. On account of this extensive range, it must experience 3600 times more light when nearest to the sun than in the most remote point of its orbit. In the one position the sun will seem to be four times larger than he appears to us, and at the other he will not be apparently larger than a star.\*

The appearance of this comet, so near the time predicted by astronomers, and in positions so nearly agreeing with those which were previously calculated, is a clear proof of the astonishing accuracy which has been introduced into astronomical calculations, and of the soundness of those principles on which the astronomy of comets is founded. It likewise shows, that comets, in general, are permanent bodies connected with the solar system, and that no very considerable change in their constitution takes place while traversing the distant parts of their orbits.†

From the preceding historical sketches and descriptions, the reader will learn something of the

\* Mrs. Somerville's "Connection of the Physical Sciences," a work which, though written in a popular style, would do honor to the first philosophers of Europe. Of this lady's profound mathematical work on the "Mechanism of the Heavens," the Edinburgh Reviewers remark—"It is unquestionably one of the most remarkable works that female intellect ever produced in any age or country; and with respect to the present day, we hazard little in saying, that Mrs. Somerville is the only individual of her sex in the world who could have written it."

† The most particular observations on Halley's comet, during its appearance in 1835, which I have seen, are those which were made by the Rev. T. W. Webb, of Tretire, near Ross, an account of which, with deductions and remarks, was read to the Worcestershire Natural History Society. The observations were made with an excellent achromatic telescope by Tulley, of 5 feet 6 inches focal length, and 4.7-10 inches aperture. Through the kindness of this gentleman I was favored with a manuscript copy of these observations, and would have availed myself of many of his judicious remarks, had my limits permitted.

general phenomena of comets; and I shall now briefly inquire into the opinions which have been formed respecting the

#### PHYSICAL CONSTITUTION OF COMETS.

On this subject our knowledge is very imperfect; in fact, we may be said to know little or nothing of the physical construction of those mysterious bodies, or of the nature of the substances of which they are composed. In regard to the *nebulosity* of comets, where there appears no nucleus, it has been conjectured to be composed of something analogous to globular masses of vapor, slightly condensed toward the center, and shining either by inherent light or by the reflected rays of the sun. When there is a nucleus in the center of a comet, it seldom happens that the nebulosity extends to it with a gradually increasing intensity. On the contrary, the parts of the nebulosity near the nucleus are but slightly luminous, and seem to be extremely rarefied and transparent. At some distance from their center, their shining quality is suddenly increased, so that it looks like a ring of invariable size resting in equilibrium around the center. Sometimes two, and even three of these concentric rings have been perceived separated by intervals; but what appears to be a ring must in reality be a *spherical covering*, an idea of which may be formed by imagining, in our atmosphere, at three different heights, three continued layers of clouds entirely covering the globe. The matter of the nebulosity is so rare and transparent that the smallest stars may frequently be seen through it.

As to the *nucleus*, it is generally considered as the solid or densest part of the comet. The *nuclei* of comets are sometimes very similar to the discs of planets, both in form and brightness. They are generally small compared with the whole size of the comet; but in some cases they are of considerable magnitude, as we have already stated in respect to the comets of 1807 and 1811. Some suppose that the nuclei of comets are transparent as well as their nebulosities, and allege as a proof that stars have been seen through a nucleus. Thus, Montaigne is said to have seen a star of the sixth magnitude through the nucleus of a small comet, and Olbers saw a star of the seventh magnitude, although it was covered by a comet, and without its light being rendered less powerful; but the accuracy of such observations has been called in question. On the other hand, it has been concluded that the nucleus of a comet has on several occasions eclipsed a star which was in the same line of vision. Messier, when observing the small comet of 1771, perceived a star which was eclipsed by the opaque body of a comet, or at least, all the circumstances attending it led to that conclusion. On the 28th of Nov. 1828, at 10h. 30', p. m., M. Wartmann, at Geneva, perceived a star of the eighth magnitude completely eclipsed by Encke's comet. Comets have likewise been observed to transit the disc of the sun like dark spots. M. Gambart, of Marseilles, calculated that a comet which he had observed would pass across the sun on the morning of the 18th of November, 1826, and both he and M. Flaugerques were successful in obtaining a sight of it during its transit. Mr. Capel Llofft, on the 6th June, 1818, at 11, a. m., saw a body passing over the sun's disc, which appears to have been a comet. It was likewise seen on the same day by Mr. Acton, at 2h. 30', considerably advanced beyond the point in which it was seen at 11, a. m., and its progress over the disc seems to have exceeded that of Venus

in transit. These observations seem evidently to indicate that some comets at least have nuclei composed of solid and opaque materials. From all the observations in relation to this point, collected by M. Arago, he deduces the following conclusions: 1. That there exist some comets destitute of the nucleus. 2. That there are other comets, the nuclei of which are transparent. 3. That there are also comets, which are more brilliant than the planets, the nuclei of which are probably solid and opaque.

In respect to the *tail*, or luminous train which generally accompanies comets, it is found that it is generally in opposition to the sun, or on the prolongation of the line which would join the sun and the nucleus. But this is not always the case. Sometimes the direction of the tail has been found at right angles with this line; and in some extraordinary instances, the tails of comets have been observed to point directly toward the sun. This was the case with a comet that appeared in 1824, which for about eight days exhibited an additional luminous train in opposition to that which assumed the ordinary direction. This anomalous tail, according to Olbers, was  $7^{\circ}$  long, while the other was only  $3\frac{1}{2}^{\circ}$ , and it was bright enough to be seen with an opera-glass. In general, however, it is found that the tail inclines constantly toward the region last quitted by the comet, as if in its progress through an ethereal medium, the matter forming it experienced more resistance than that of the nucleus. The tail is generally enlarged in proportion to its distance from the head of the comet, and in certain cases it is divided into several branches, as already noticed of the comet of 1807. Some have supposed that the divided tail is nothing more than a perspective representation of the sides of a great hollow cone; but there are certain observations which seem to prove that, in some cases, they have a separate existence as independent branches. The most remarkable instance of a divided tail was in the comet of 1744. On the 6th and 7th of March, there were six branches in the tail, each of them about  $4^{\circ}$  in breadth, and from  $30^{\circ}$  to  $40^{\circ}$  long. Their edges were pretty well defined and tolerably bright; their middle emitted but a feeble light, and the intervening spaces were as dark as the rest of the firmament. The tails of comets, as already noticed, sometimes cover an immense space in the heavens. The comet of 1680 had a tail which extended to  $60^{\circ}$ , that of 1811 to  $23^{\circ}$ , and that of 1769 to  $97^{\circ}$  in length; so that some of these tails must have reached from the zenith to the horizon. The length of the tail of the comet of 1680, estimated in miles, was 112,750,000; that of 1769, 44,000,000; and that of 1744, 8,250,000 miles. A body moving at the rate of 20 miles every hour would not pass over the space occupied by the tail of the comet of 1680 in less than 643 years. It has been supposed by some astronomers that certain changes in the appearance of the tails of comets arise from the rotation of the cometary body; as some comets have been supposed to rotate about an axis passing through the center of the tail, such as that of 1825, which was concluded from certain appearances, to perform its rotation in 20 hours, 50 minutes.

As to the nature of the immense tails of comets, their origin, or the substances of which they are composed, we are entirely ignorant, and it would be wasting time to enter into any speculation on this subject, as nothing could be presented to the view of the reader but vague conjectures, gratuitous hypotheses, and unfounded theories.

## MISCELLANEOUS REMARKS ON COMETS.

1. *Whether comets shine with their own native light, or derive their light from the sun?*—This is a question about which there have been different opinions, and at the present moment it may be considered as still undetermined, though the probability is, that in general, they derive their light from the same source as the planets. It appears to have been the opinion of both Schroeter and Herschel, that the comet of 1811 shone by inherent light; and the rapid variations which have been observed in the brightness of the nucleus, and the concussions of the tail, are considered by some as inexplicable on any other hypothesis. It is likewise supposed that certain phenomena which have been observed in the case of faint and rarefied comets tend to corroborate the same position. For example, Sir J. Herschel, on September 23, 1832, saw a small group of stars of the 16th and 17th magnitude through the comet of Biela. Though this group could have been effaced by the most trifling fog, yet they were visible through a thickness of more than 50,000 miles of cometary matter; and therefore it is supposed scarcely credible that so transparent a material, affording a free passage to the light of such minute stars, could be capable of arresting and reflecting to us the solar rays. On the other hand, it has been objected to this opinion, that comets have appeared as dark spots on the disc of the sun; that their light exhibits traces of *polarization*; and that they have been occasionally observed to exhibit *phases*. M. Arago remarks, that "on the very day that any comet shall appear with a distinct phase, all doubts on this subject will have ceased." But it is considered doubtful whether any *decided phase* has yet been perceived, although some observers were led, from certain phenomena to infer that something like a phase was presented to their view. It is found that all direct light constantly divides itself into two points of the same intensity when it traverses a crystal possessing the power of double refraction; reflected light gives, on the contrary, in certain portions of the crystal through which it is made to pass, two images of unequal intensity, provided the angle of reflection is not  $90^{\circ}$ ; in other words, it is *polarized* in the act of reflection. On this principle, M. Arago pointed out a photometrical method of determining whether comets borrow their light from the sun, or are luminous in themselves. On the 23d of October, 1835, having applied his new apparatus to the observation of Halley's comet, he immediately saw two images presenting the complementary colors, one of them red, the other green. By turning the instrument half round, the red image became green, and *vice versa*. He concluded therefore that the light of the comet, at least the whole of it, is not composed of rays possessing the property of direct light, but consists of that which is *polarized* or reflected specularly: that is, of light derived from the sun. These experiments were repeated with the same result by three other observers in the Observatory of Paris.

2. It appears to be a remarkable fact in respect to comets, that *the real diameter of the nebulousness increases proportionally as the comet becomes distant from the sun*. Hevelius appears to have been the first who made this observation; but it seems to have been overlooked, and even an opposite position maintained. As the tails of comets increase in length as they approach their perihelia, so it was generally considered that the

nebulosities followed the same law; but the observations which have lately been made on Biela's comet have confirmed the observations of Hevelius. On the 25th of October, 1828, this comet was found to be nearly three times farther from the sun than on the 24th of December, or in the proportion of 1.4617, to 0.5419, yet in October its diameter was about twenty-six times greater than in December, or in the proportion of 79.4 to 3.1; that is, its solid contents on the 25th of October were 16,800 times greater than on the 24th of December, and the *smallest* size of the comet corresponded to its *least* distance from the sun. M. Valz, of Nîmes, and Sir John Herschel have attempted to account for this circumstance on very different principles, but neither hypothesis appears to be satisfactory.

3. *Whether a comet may ever come in contact with the earth, and produce a concussion?*—As comets move in orbits which form extremely elongated ellipses; as they move in all imaginable directions; as they traverse almost every part of the solar system in returning from the farthest verge of their excursions; as they penetrate within the interior of the planetary orbits—even within the orbit of Mercury, and cross the orbits of the earth, and the other planets, it is *not impossible* that a comet may come in contact with our globe. An apprehension of such an event produced a considerable degree of alarm on the continent at different periods, particularly in 1773 and 1832, as formerly stated. But when we consider the immense cubical space occupied by the planetary system in which the comets move, and compare it with the small capacities of these bodies; and when we take into view certain mathematical calculations in reference to the subject, the probability of a shock from a comet is extremely small. "Let us suppose," says Arago, "a comet of which we only know that at its perihelion it is nearer the sun than we are, and that its diameter is *one-fourth* of that of the earth, the calculation of probabilities shows that of 281,000,000 of chances there is only one unfavorable, there exists but one which can produce a collision between the two bodies. As for the *nebulosity*, in its most general dimensions; the unfavorable chances will be from ten to twenty in the same number of two hundred and eighty-one millions. Admitting then, for a moment, that the comets which may strike the earth with their nuclei would annihilate the whole human race, then the danger of death to each individual, resulting from the appearance of an *unknown* comet, would be exactly equal to the risk he would run if in an urn there was only one single white ball of a total number of 281,000,000 balls, and that his condemnation to death would be the inevitable consequence of the white ball being produced at the first drawing."

When we consider that a Wise and Almighty Ruler superintends and directs the movements of all the great bodies in the universe, and the erratic motions of comets among the rest; and that no event can befall our world without his sovereign permission and appointment, we may repose ourselves in perfect security that no catastrophe from the impulse of celestial agents shall ever take place but in unison with his will, and for the accomplishment of the plans of his universal providence. At the same time, the *possibility* of a shock from a large comet shows us that this earth and all its inhabitants are dependent for their present existence and comforts on the will of an Almighty Agent, "in whom we live, and move, and have our being;" and that were it conformable to his allwise and eternal designs

he could easily disarrange the structure of our globe, and reduce its inhabitants either to misery or to complete destruction; and that, too, without altering a single physical law which now operates throughout the universe.

If we recognize the Scriptures as a revelation from God, we may rest assured that no danger from such a cause can happen to our world for ages yet to come; for there are many important predictions contained in Revelation which have not yet received their accomplishment, and must be fulfilled before any fatal catastrophe can happen to our globe. It is predicted that the Jews shall be brought into the Christian church "with the fullness of the Gentiles,"—that "the idols of the nations shall be abolished,"—that "war shall cease to the ends of the earth,"—that the kingdom of Messiah shall extend over all nations,—that "the knowledge of Jehovah shall cover the earth, and that all shall know him from the least to the greatest,"—that "the earth shall yield its increase," and its desolate wastes be cultivated and inhabited,—that moral order shall prevail, and "righteousness and praise spring forth before all the nations,"—and that this happy era of the world shall continue during a lapse of ages. These events have not yet been accomplished, though at the present moment they appear either in a state of commencement or of progression; but they cannot be supposed to be fully realized until after a lapse of centuries. The believer in Divine revelation, therefore, has the fullest assurance that, whatever directions comets may take in their motions toward the center of our system, none of them shall be permitted to impinge upon our globe, or to effect its destruction, for at least a thousand years to come, or until the above and other predictions be completely accomplished.

4. Another question occurs on this subject—namely, *whether any comets have ever fallen into the sun?*—It was the opinion of Sir Isaac Newton that one purpose for which comets are destined is, to recruit the sun with fresh fuel, and repair the great consumption of his light by the streams continually emitted every way from that luminary; and that such comets as come very near the sun in their perihelions meet every time with so much resistance from his atmosphere as to abate their projectile force: by the constant diminution of which, the centripetal power, or gravitation toward the sun, would be so increased as to make them fall into his body. On a similar principle, Arago supposes that the comet of 1680, which approached so near the body of the sun, must have passed nearer to his surface at that time than at its preceding apparitions; that the decrease in the dimensions of the orbit will continue on each succeeding return to its point of perihelion; and that "it will terminate its career by falling upon the sun." But he acknowledges that, "from our ignorance of the densities of the various strata of the sun's atmosphere, of that of the comet of 1680, and of the time of its revolution, it will be impossible to calculate after how many ages this extraordinary event is to happen;" and he likewise admits that, "the annals of astronomy do not afford any reason to suppose the previous occurrence of such an event since the origin of historical record;" so that we have no direct evidence that such an event has ever taken place, or that it ever will. We know too little of the physical constitution of the sun, and of the nature of comets, to be able to assert that the falling of a comet into the sun would actually recruit the luminous matter of which his outer surface is composed; for we have reason to believe that there



Is little or no analogy between the mode in which we supply our fires by means of fagots, and that by which the solar light is recruited and preserved in its pristine vigor; and beside, it is found that bodies, particularly in certain electric states, may be rendered luminous without the addition of any extraneous body to their substances.

## OF THE INFLUENCE OF COMETS ON THE EARTH.

In former times the appearance of comets was supposed to be the forerunner of wars, revolutions, famine, pestilence, the deaths of great men, earthquakes, inundations, and other calamities. When the splendid comet of 1456 appeared (supposed to be the same as Halley's comet), its tail extended at one time over more than 60 degrees. Three days before its perihelion, its nucleus was as bright as a fixed star, its tail of the color of gold, and it appears to have exhibited conascations. Pope Calixtus, believing it to be at once the sign and instrument of Divine wrath, was so frightened at its appearance that he ordered public prayers to be offered up in every town, and the bells to be tolled at the noon of each day to warn the people to supplicate the mercy of Heaven. He at the same time excommunicated both the comet and the Turks, whose arms had lately proved victorious against the Christians, and established the custom, which still exists in Catholic countries, of ringing the church bells at noon. In modern times, certain natural effects have likewise been attributed to the influence of comets; such as tempests, hurricanes, volcanic eruptions, cold or hot seasons, overflowings of rivers, fogs, dense clouds of flies or locusts, the plague, the dysentery, the cholera, and other disorders.

Mr. T. Forster, a respectable writer on natural science, author of "Researches about Atmospheric Phenomena," &c., published in 1829 a work on the "Atmospherical Causes of Epidemic Diseases," in which he maintains that the most unhealthy periods are those during which some great comet has been seen; that the appearance of these bodies has been accompanied by earthquakes, eruptions of volcanoes, and atmospheric commotions; and that no comet has been seen during seasons of healthiness. For example, in the year 1665 a comet made its appearance, and soon after its disappearance, the city of London was ravaged by the plague. In 1680 one of the most splendid comets which have been observed in modern times made its appearance. The atmospheric effect produced by its influence, according to Mr. Forster, was "a cold winter, followed by a dry and hot summer," and "meteors in Germany."

As the influence of comets on our globe and its atmosphere (if such an influence exist) must have a respect to the whole earth, and not merely to any particular portion of it, we might ask in reference to the first example, why did not the comet of 1665, produce a similar effect in Amsterdam, Vienna, Paris, and Madrid, and in the principal cities of Asia, Africa, and America? But of such effects we never had the least intimation. In respect to the second example, we are warranted to inquire, whether the cold winter was followed by a hot summer in every other climate of the earth? whether meteors were as common in other countries as in Germany? and whether the comet produced opposite effects, at one time congealing the pools and rivers, and at another scorching the earth with heat? If such questions cannot be satisfactorily answered, we are not warranted in attributing such effects to the influence of comets.

We err egregiously, in this as well as in many other respects, when we infer, from two contemporaneous events, that the one is either the sign or the cause of the other. It is on a principle of this kind that some persons are led to attribute the events to which we have alluded to the influence of comets. Because an inundation, a war, a political convulsion, or a volcanic eruption has taken place at the time of the approach of a comet to this part of our system, therefore they conclude that there must be a certain connection between such events, and that the one is the cause, and the other the effect; while the two events, in point of fact, may not have the slightest relation to each other, except their casual occurrence at the same period. We might, on the same grounds, infer that the rising of the star *Sirius* along with the sun, which announced to the Egyptians the rise of the Nile, was the cause of the annual overflowing of that river. Before we can identify any event with the influence of a comet, we must not confine our views to an event or two in our immediate neighborhood, but must endeavor to ascertain whether similar events or phenomena have happened on every part of the earth at the same period. As comets, either large or small, either visible to the naked eye or through a telescope, make their appearance at an average almost every year, and as epidemics, political commotions, earthquakes, hurricanes and similar events are always to be found occurring in some particular portions of the globe, we should never be at a loss for a physical cause to account for everything that happens here below, if comets are to be supposed to have such an influence over terrestrial affairs. Whatever takes place in any country of an uncommon nature might then be attributed to a comet which is either approaching the center of our system or receding from it.

It is remarkable that the announcement of a comet has generally been received with melancholy anticipations, and the effects attributed to its influence have uniformly been of a calamitous nature. But why should it not be the precursor of prosperous events—of peace, plenty, social tranquility, and genial seasons—as well as of wars, famines, revolutions, cold winters, and parched summers? It seems something like a reflection on the general benevolence of the Deity to imagine that he has created such a vast number of bodies, and directed their course through every part of the planetary regions, chiefly for the purpose of "shaking from their horrid hair" wars, famine, and pestilence; for if they produce such effects upon the earth, we might with equal reason believe that they produce similar effects on the other planets of our system as they pass along in their course toward the sun; and this would lead us to infer that the inhabitants of all the planetary orbs are liable to the same disasters and calamities as the inhabitants of the earth; a position which seems scarcely consistent with the boundless benevolence of the Divine mind.

But although I do not admit the conclusions and the cometary influences to which I have alluded, I am far from asserting that comets have no influence whatever over our globe or its surrounding atmosphere. The universe is one great whole, and all its parts, however remote, must be supposed to have a certain relation to one another; and they may produce an influence, however small and imperceptible, on each other at the greatest distances. The remotest star perceptible to the eye may produce a certain physical influence on our globe, though so small and insensible as to be beyond the limits of the nicest calcula-

tion; and therefore comets which sometimes approach pretty near the earth may produce a certain sensible effect upon our globe, particularly should a portion of their immense tails at any time sweep along the higher regions of our atmosphere. But what special influence or effects they may produce on the physical economy of our terrestrial system it is impossible for us, in the meantime, distinctly to ascertain, from our ignorance of the constitution of those mysterious bodies, and of the substances of which they are composed. While too much has doubtless been attributed to the influence of comets, it would be verging to an opposite extreme to maintain that they can produce no effect at all on our earth and atmosphere. We know that certain celestial bodies produce a powerful influence on our globe. The moon, in conjunction with the solar influence, rules the ocean and perpetuates the regular returns of ebb and flow. Its light not only cheers our winter nights, but produces a variety of other influences both on the human constitution, of the atmosphere, and on the productions of the earth; and there may be many effects produced by its agency with which we are as yet unacquainted.\* The sun not only diffuses light over every region of the earth for the purpose of vision, but rays or emanations invisible to our sight proceed from his body, which promote evaporation, the growth of vegetables, and the various degrees of temperature which prevail throughout the globe. These emanations are likewise found to produce certain chemical effects, to dissolve certain combinations of oxygen, and to give polarity to the magnetic needle; and many other effects, of which we are ignorant, may afterward be found to proceed from those invisible irradiations. The larger planets, Jupiter and Saturn, and those which are nearest to us, as Venus and Mars, may likewise produce certain effects on our globe, both in virtue of their attractive power and of the peculiar nature of the reflected rays they transmit to the regions we occupy.

We cannot therefore but conclude, that comets may exert a peculiar influence on our terrestrial system in addition to that of other celestial bodies, and different from it, particularly those whose bulk and masses are considerable, and which approach nearest to the earth. Their light, whether

native or reflected, appears to be peculiar, and the margin of their immense tails may occasionally graze our atmosphere when we are not aware of it, and may produce a peculiar effect different from that produced by the other bodies of our system; but what that special effect is has not hitherto been determined; for the mere coincidences of certain events with the appearance of comets cannot be supposed to be owing to their peculiar influence, unless such events are found uniformly to happen on the apparition of a comet, and that too throughout a great portion of the earth. This subject is worthy of some attention; and perhaps future observers, by more accurate observations than have hitherto been made, may throw some light on an influence which, on the one hand, has been perhaps too rashly set aside, and on the other, carried to a pitch of extravagance beyond the line of sober reason and observation.

Let it not be supposed that, in admitting that comets may have an influence on our globe, I mean to give the least countenance to foolish superstitions, or to the absurdities of astrology, since all that I would be disposed to admit in the present case is purely a *physical* influence; an influence which may exist, although we have not yet been able to discriminate its specific effects. The most eminent philosophers have been disposed to admit such an influence. Sir Isaac Newton supposed that "the atmospheres and tails of comets may supply the planets with moisture, which is continually wasting by the growing of vegetables out of water and turning into earth;" and that from the same source may be derived "the purest part of our air, which is requisite for the existence of living beings." These opinions, indeed, cannot be proved, and they are evidently untenable; but they show that that great philosopher admitted the influence of comets. M. Arago, although he scorns the vulgar idea of comets being the cause of most calamitous events, yet he admits that, "not only cometary matter may fall into our atmosphere, but that this phenomenon is of a nature to occur frequently, and may possibly produce those epidemic diseases which have been attributed to it."

A variety of questions has been started respecting cometary action and influence, beside those to which we have now alluded. It has been a question whether we ought to have recourse to the action of a comet to account for the *rigor* of the climate of North America? It is found that in the northern regions of America, the climate in the same latitude is much colder than in Europe. To account for this, Dr. Halley supposed that a comet had formerly struck the earth obliquely, and changed the position of its axis of rotation. In consequence of that event, the North Pole, which had been originally very near to Hudson's Bay, was changed to a more easterly position; but the countries which it abandoned had been so long a time, and so deeply frozen, that vestiges still remain of its ancient polar rigor, and that a long series of years would be required for the solar action to impart to the northern parts of the new continent the climate of their present geographical position. But we have no proof that a comet has ever struck the earth, or that its concussion would have the effect to change the direction of the terrestrial axis. Beside, it is well known that the Asiatic coast is equally cold in the same latitudes as the Atlantic shores of North America.

It has likewise been a subject of inquiry whether the depression of the soil of a great part of Asia has been produced by the shock of a comet;

\* It is stated by Mr. Martin, in his "Description of the Western Isles," that "peat dug in the increase of the moon continues moist and never dries clear, while the contrary is observed of that cut in the decrease; and that earthen dykes thrown up in the latter season are alone found to possess stability." It is also stated as a fact, that "if an animal flesh killed be exposed to the moon's rays, it will in a few hours become putrid, while another animal, only a few feet distant, protected from their influence, will not be in the least affected; that fruits exposed to moonlight have been known to ripen much more readily; that plants bleached in the dark recover their color from the beams of a full moon; and that in south America, trees cut at the full moon split almost immediately, as if torn asunder by great external force. Fish are said to be rapidly decomposed in the West Indies when taken by moonlight."—*Hobbs's MS. Treatise on Comets.* Unless such alleged facts can be disproved, we must admit that the moon may have a certain influence in such cases, though we may be unable to explain the mode by which it is effected. In Carne's "Letters from the East," we are told, that "the effect of the moonlight on the eyes in eastern countries is singularly injurious. The natives tell you always to cover your eyes when you sleep in the open air. The moon here really strikes or affects the sight, when you sleep exposed to it, much more than the sun; a fact of which I had a very unpleasant proof one night, and took care to guard against it afterward. Indeed, the sight of a person who should sleep with his face exposed to the moon at night would soon be utterly impaired or destroyed." This circumstance strikingly illustrates the expression of the Psalmist—"The sun shall not strike or smite thee by day, nor the moon by night."

and whether Siberia ever experienced a sudden change by a similar event? This latter inquiry has been suggested by the circumstance of the bones of elephants, rhinoceroses, and other animals peculiar to the torrid zone, having been found imbedded in the strata of that country, which has led to the supposition that Siberia was, at some remote period, comprised within the tropics. But there is no proof, nor even probability, that the action of a comet was concerned in either case. It has also been supposed that the small planets, Vesta, Juno, Ceres, and Pallas, the supposed fragments of a large planet, may have been broken to pieces by the shock of a comet. The circumstance that two of these planets, Ceres and Pallas, are encompassed with an atmosphere of great density and elevation has been brought forward as a presumptive proof of the reality of such a concussion, and that the cometary atmosphere, not being liable to destruction by the percussion, was imparted to these planets. But when we consider the very small density of comets, it appears not at all probable that even a direct concussion from such a body would have produced such an effect, although it might have caused a considerable derangement of the physical constitution of the planet. Beside, this hypothesis does not account for the remarkable fact that Vesta and Juno exhibit no traces of an atmosphere which, in consistency with the supposition, ought to have been imparted to them by the comet, as well as to Ceres and Pallas. On the whole, we have no direct or satisfactory proofs that comets have ever come in direct contact with our globe, or that they have produced any considerable derangements throughout the planetary system; and whatever specific influence they may produce on our earth and atmosphere must be deduced from future observations.

#### ON THE INHABITABILITY OF COMETS.

Some philosophers have been disposed to doubt whether the constitution of comets be at all fitted for the abode of rational beings, especially when we take into consideration the extremes of heat and cold to which they would be subjected in their long and extensive career. Mr. Whiston supposed that on this account they could not be the abodes of happiness, and therefore was led to believe that they were the places of punishment for the wicked, who were alternately wheeled into regions of intolerable heat, and afterward exposed to all the rigors of the most intense cold. But when we consider the boundless beneficence of the Divine Being, and that "his tender mercies are displayed over all his works," we cannot for a moment suppose that so vast a number of these bodies would be created for such an end. The celebrated Lambert, on the other hand, considers comets as constituting some of the most splendid regions of the universe, and that their inhabitants are permitted to contemplate the scene of nature on a scale of grandeur far surpassing that which is presented to the population of the planets.

Many of the comets which exhibit no signs of a nucleus appear to be composed of very light, transparent, and gaseous substances; and therefore it is not very probable that such bodies are inhabited. Comets in this state are supposed by some philosophers, to be only approaching to a state of consolidation. But as to those which have a large and solid nucleus, there appears to be no physical impossibility, nor even improbability, of their being the abodes of sentient and intellectual beings, as well as the other moving bodies

of our system. The extremes of heat and cold to which comets are supposed to be subjected form the principal argument against the opinion that these bodies are inhabited. But in reply to such an objection it may be stated, that we have no proof that heat or cold depend altogether on the distance of a body from the sun, but most probably on certain circumstances connected with the constitution of the body itself. Beside, it is a fact, that in the heating of bodies there is a certain point, beyond which their temperature can never be raised; as, for instance, in the case of water, which cannot be heated beyond the point of 212° of Fahrenheit's thermometer; and therefore the surface of a comet may have a certain point beyond which its temperature can never be elevated, even at its nearest approach to the sun. "When, by any means," says Mr. Milne, "the density of bodies is made to change by a process, whether of rarefaction, on the one hand, or of condensation on the other, they are always found to undergo a corresponding diminution or increase of temperature. When, therefore, in the approach of a comet to the sun, all the parts of its nebulous envelope and tail which in the remoter regions of its course had been gathered close about the head, become expanded and attenuated, a very large proportion of the solar heat, which would otherwise have passed into the nucleus, and contributed to raise its temperature to a certain point, is carried off by the envelope and tail, in order to preserve an equilibrium among the several parts." Mr. Milne proves that, if we assume that the nebulous matter is elevated about 30 times its former height, the diminution of density corresponding with the increase of volume will amount to 27,000, and that a quantity of caloric will be extracted corresponding to 1,215,000° of Fahrenheit. He further shows that, "when the comet retires toward its aphelion, where the heat of the sun becomes so much weakened on account of the distance, the condensation of the nebulous matter forming the tail and envelope serves not only to furnish the nucleus with continual supplies from the heat acquired at the perihelion, but even to render the warming influence of the solar rays much more efficacious than at a less remote part of the comet's orbit."\*

The extremes of heat and cold, therefore, in comets may not be so great as at first view we should be apt to imagine, and their constitution may be such as is not incompatible with the idea that they are inhabited by animated beings. We are not, however, to suppose that the constitution of beings like man would be adapted to the circumstances and changes to which comets are subjected, nor is such a supposition necessary in order to prove their inhabitability. For in the case of all worlds and beings, we must necessarily admit that the Creator has adapted the constitution of the inhabitants to the nature of the habitation. We find a striking variety in this respect in the constitution of the numerous orders of sentient beings that people the globe on which we live; and a similar variety doubtless exists in the peculiar constitutions of the inhabitants of the different planets, and of all the worlds in the universe. For anything we can prove to the contrary, some of the comets may be the abodes of greater happiness than is to be found in our sublunary world, and may be peopled with intelligences of a higher order than the race of man. In consequence of the extensive regions through which they move

\* Milne, Prize Essay on Comets, Part IV.

and the variety of objects which will successively burst upon their view, their prospects of the scenes of the universe will be far more diversified and expansive than those of the inhabitants of the planets.

At one period they will behold the stupendous globe of the sun filling a great portion of their celestial hemisphere, and be enabled to contemplate the august and splendid operations going on upon its surface and in its luminous atmosphere, a spectacle of grandeur which must be beyond conception sublime and overpowering. At another period they will be enabled to survey, at no great distance, the phenomenon and economy of some of the planetary worlds. The comet of 1741 passed within 180 terrestrial diameters, or 1,440,000 miles of the earth's surface, at which time its inhabitants (if any) would enjoy an interesting view of our earth and moon, with their diversified motions, and the general aspect of their surfaces. The same comet twice traversed the system of Jupiter's satellites, when the magnificent globe of Jupiter would appear at least 300 times larger than the moon appears to us, and when its satellites would likewise present a very large and splendid appearance. From such a position, even with eyes such as ours, assisted by telescopes, all the diversity of surface of this huge globe, as presented in its diurnal rotation, with the changes of its belts, and the peculiar scenery of its satellites, would be distinctly perceived. Above all, the system of Saturn will present a most magnificent spectacle to the inhabitants of a comet when it passes through the regions in its immediate vicinity. Its expansive rings, filling a considerable portion of the visible firmament, their rapid rotation round the planet, the vast globe of Saturn itself, and the numerous satellites which accompany it, in all their different phases and rapid motions, will present a scene at once diversified and sublime. To the inhabitants of comets, many vast bodies within the range of our system may be visible, which we have never yet discovered, and which may never be perceptible from the region we occupy. Traversing vast regions of space far beyond the orbit of Uranus, and perhaps approaching to the nearest stars, worlds may be presented to their view of which we have no conception, and the planets which revolve around other suns may be distinguishable in the remoter parts of their course. Enjoying such diversified and extensive prospects of the operations of Omnipotence, the intellectual beings who reside on those bodies will acquire more expansive views than the inhabitants of the earth of the vast scene of nature and of the perfections of that Allwise and Almighty Being whose power brought into existence, and whose incessant energy sustains in being, all the worlds in the universe.

The number of comets is supposed by some astronomers to amount to several millions; and if so, they must frequently pass near each other in their long eccentric courses, and consequently the beings connected with them will have their prospects of other worlds wonderfully diversified and continually expanding. It is likewise supposed that comets sometimes extend their excursions to other suns. On this point M. Lambert has the following remarks: "I shall suppose that a globe in our system begins to describe a parabola. If this curve closes and returns into itself, the globe will remain with us, and acquire a periodical motion round the sun. If, on the contrary, it extends its limits, so as to become a hyperbola, the globe will recede more and more from the sun, and leave us, never to return. Were we to pursue the

fugitive in idea, we should see it perhaps at the end of some thousands of years flit along the frontiers of our system and dive into a neighboring world. The central body of this world would then exercise its attraction over the new visitor, and give a curvature to his orbit. From that moment one of two things would happen. Either its path would change into an ellipse, in which case its travels would be at an end, and it would proceed to make regular revolutions round the dominant star of that system; or, perhaps, after passing its perihelion, it would again resume its hyperbolic progress, and approaching the asymptote, withdraw in a straight line, and proceed to visit other worlds. Thus we can conceive comets which, being attached to no particular system, are in common to all, and which, roaming from one world to another, make the tour of the universe. I ask why, in the infinite variety which the Creator has introduced into his works, such globes should not have a place? Their destination may embrace the wisest purposes, concerning which we may be allowed to speculate."

This celebrated philosopher concludes his remarks on comets with the following reflections, which, although somewhat fanciful, may not be unworthy of the attention of the reader:

"I love to figure to myself those traveling globes, peopled with astronomers, who are stationed there for the express purpose of contemplating nature on a large, as we contemplate it on a small scale. Their movable observatory cruising from sun to sun, carries them in succession through every different point of view, places them in a situation to survey all, to determine the position and motion of each star, to measure the orbits of the planets and comets which revolve round them, to observe how particular, are resolved into general laws, in one word, to get acquainted with the whole as well as the detail. We may suppose that their year is measured by the length of their route from one sun to another. Winter falls in the middle of their journey; each passage of a perihelion is the return of summer; each introduction to a new world is the revival of spring; and the period of quitting it is the beginning of their autumn. The place of their abode is accommodated to all their distances from the fixed stars, and the different degrees of their heat make the fruits and vegetables designed for their use blossom and ripen. Happy intelligences, how excellent must be the frame of your nature! Myriads of ages pass away with you like so many days with the inhabitants of the earth. Our largest measurements are your infinitely small quantities; our millions the elements of your arithmetic; we breathe but a moment; our lot is error and death, yours science and immortality. All this is agreeable to the analogy of the works of creation. The frame of the universe furnishes matter of contemplation as a whole as well as in each of its parts. There is not a point that does not merit our observation; this magnificent fabric is portioned out in detached parts to created beings; but it is in the unity of the whole that sovereign perfection shines; and can we suppose that this whole has no observers? The imagination, indeed, after so sublime a flight, may be astonished at its own temerity; but, in short, here the cause is proportioned to the effect, and there is nothing great or small in immensity and eternity."

#### ON THE MOTIONS AND ORBITS OF COMETS.

When a comet comes within the limits of our view, its apparent motion is from east to west, and

It generally appears to rise and set like most of the other heavenly bodies. This motion, however, like that of the diurnal motion of the sun and planets, is only *apparent*, and arises from the rotation of the earth upon its axis. Beside this apparent motion, it has a *real* and proper motion of its own, by which it is continually shifting its place in the heavens, in conformity to the nature of the orbit in which it moves. "The proper course of a comet may be found by observing every night its distance from two fixed stars whose longitudes and latitudes are known; or by finding its altitude when in the same azimuth with two known fixed stars; or by noting four fixed stars in the point of intersection of the two lines connecting which the comet is found. If the places of the comet as thus observed every night, be marked on the celestial globe, a line drawn through them will represent the comet's path among the stars; a great circle drawn through three distant places will nearly show the way it has to go. If it be continued until it intersect the ecliptic, it will show nearly the place of the node and the inclination of the orbit to the ecliptic.\* There is, however, a practical difficulty which perplexes the observer in attempting to ascertain the true form of a cometary orbit. A comet remains so short a time in sight, and describes so small a part of its course within our view, that, from observation alone, without the assistance of hypothesis, we should not be able to determine the nature of its path. The only part of the course of a comet that can ever be visible is a portion throughout which the ellipse, the parabola, and hyperbola, so closely resemble each other that no observations can be obtained with sufficient accuracy to enable us to distinguish them. The hypothesis most conformable to analogy is, that the comet moves in an ellipse, having the sun in one of the foci, and that the *radius vector* from the sun to the comet describes areas proportional to the times, according to the law observed by the planets. If it be supposed that the comet describes an ellipse or a parabola, in conformity to the laws of Kepler, then from three geocentric places, known by observation, the orbit may be determined.

The orbits of the planets, although elliptical, approach very nearly to circles; but those of comets are extremely eccentric, and form very elongated ellipses. The orbit of Halley's comet is four times longer than it is broad, and the orbits of those comets whose periodical revolution exceeds a hundred or a thousand years must be still more elongated and eccentric. Fig. 82 represents the orbit of Halley's comet nearly in its exact proportions. *EC* represents the length of the ellipsis in which it performs its revolution; *ED*, the orbit of the earth, somewhat larger than it ought to be in proportion to the comet's orbit; *S*, the sun in one of the foci of the ellipse; *Sat*, the proportional distance of the planet Saturn from the sun; and *U*, the proportional distance of Uranus. The orbit of this comet extends to nearly double the distance of Uranus.

Fig. 83 represents so much of the trajectory of the comet of 1680 as it passed through while visible to the inhabitants of our globe, as delineated in Newton's "*Principia*." It shows also the tail as it appeared on the days mentioned in the figure.

Like that of other comets, it increased in length and brightness as it came nearer to the sun, and grew shorter and fainter as it went farther from that luminary and from the earth, until the comet was too distant to be visible. This comet was observed in the morning from November 4, to November 25, 1680, in its descent toward its perihelion

Fig. 82.

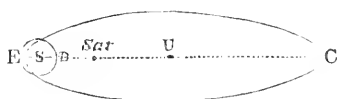

at *P*; and its positions on the 17th, 21st, and 25th of that month are here exhibited. It appears to have passed its perihelion sometime between the 25th of November and the 12th of December.

Fig. 83.

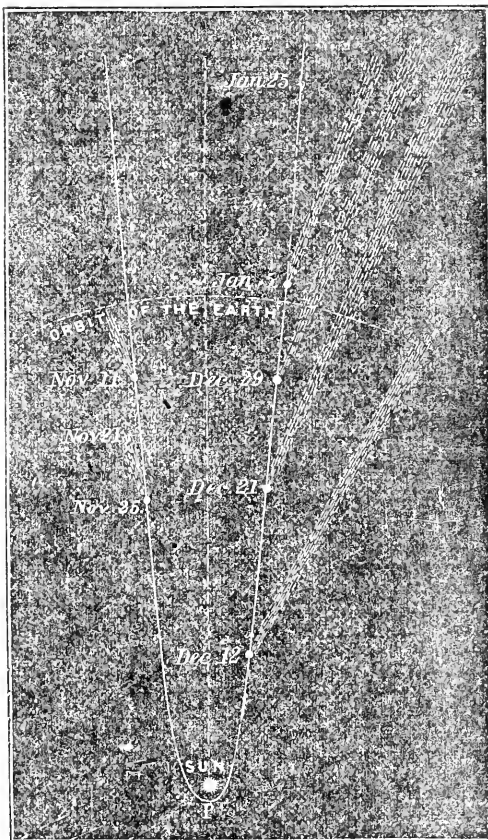

Its positions on the 12th, and 21st, and 29th of December, and on the 5th and 25th of January, 1681, after returning from its perihelion, as seen in the evening, are marked in the figure. The orbit of this comet must be extremely elongated, as its return is not expected for more than 400 years to come.

Fig. 84, taken from Arago's "*Scientific Notices of Comets*," exhibits a representation of the orbit of Biela's comet, with the relative position of the orbit to the earth. It shows both the space and the position it occupies in the solar system, and the points where its orbit intersects all the

\* Dr. O. Gregory's "Treatise on Astronomy."

planetary orbits through which it passes. It exhibits its course at its return in November, 1832, and the path it describes until its subsequent return in 1839. From this figure, it is seen that its perihelion lies between the orbits of the earth and Venus, and that its aphelion extends beyond the orbit of Jupiter. It would arrive at that point which is most distant from the earth, in the spring of 1836, and will probably return to it in January, 1842. The nearest approach to the earth of this comet was 51 millions of miles; its nearest approach to the sun, 83 millions; its mean distance from the sun, or half the longest axis of its orbit, 337 millions; and it is 507 millions of miles nearer the sun in its perihelion than in its aphelion. To

Fig. 84.

REPRESENTATION OF THE ORBIT OF THE COMET OF 1832, WITH THE RELATIVE POSITION OF THE ORBIT OF THE EARTH.

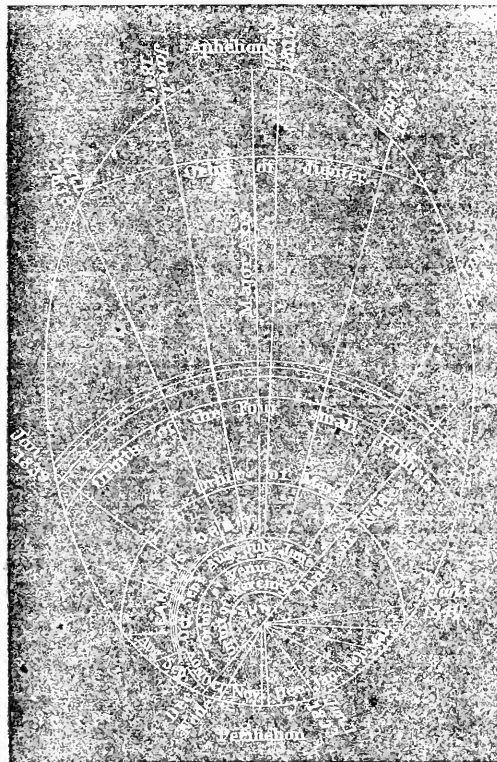

be able to calculate and predict the future positions and appearances of such a body evinces an accuracy of observation, and a degree of perfection of astronomical *calculus*, which may justly challenge admiration, and which should lead those who are unacquainted with the minutiae of astronomy to receive with confidence the results which have been deduced by those who have devoted themselves to celestial investigations.

#### SUPPOSED NUMBER OF COMETS.

It is laid down as a principle by M. Lambert, that as the world is the expression of the perfections of God, we must believe that all the heavenly bodies are inhabited, and that *universal space is replenished with as many globes as it can con-*

tain," so as to move with freedom and security within the circumference of the universe. Hence he infers, that the most perfect plan of our system will be that into which enters the greatest number of orbits, all separated from one another, and which in no one point intersects the other; and that the orbits of comets correspond to this end better than those of the planets, as an immensely greater number of elliptic or cometary orbits can be introduced into the system than those which are circular. On the ground of the number of comets which have hitherto been observed, and on certain mathematical considerations, he institutes calculations which led to the conclusion that "at least five hundred millions of comets" might be contained within the limits of the solar system. On this point, M. Arago reasons in the following manner:—The number of comets really known, whose perihelion distance is less than the radius of the orbit of Mercury, amounts to thirty. This radius, and that of the orbit of Uranus, are in the ratio of 1 to 49; and the volumes of two spheres are to each other as the cubes of their radii. If, therefore, we adopt the hypothesis of the equal distribution of comets in all the regions of our system, and calculate the number of those luminaries whose perihelions are included in a sphere whose radius is the distance of Uranus from the sun, the following proposition would be supplied to us:—As the cube of 1 : to the cube of 49 :: 50 is 30 : to the number of comets sought;—or thus, 13 : 493 :: 30 ; or, 1 : 117,649 :: 30 : 3,529,470. Thus within the orbit of Uranus, the solar system should contain more than three millions and a half of comets; or, we should rather find the double of that the true number, when we consider that in this calculation the term which represents the number of comets contained within the sphere of Mercury is certainly much too small, and that it ought to be conceived that the light of day, our clouded skies, and a too southerly declination, removes from our sight not fewer than every alternate one of these bodies. Taking these circumstances into consideration, there should, on the same hypothesis, be seven millions of comets.

The actual number of comets, however, which have been observed since the commencement of the Christian era, does not amount to above seven or eight hundred; but when we consider that in the earlier ages of astronomy, and likewise in more recent periods before the invention of the telescope, only large and conspicuous comets were noticed, and that the greater number, in all probability, had their visible courses in the southern regions of the heavens, and of whose appearance we have no records, it will easily be conceived that their actual number must amount to at least many thousands. Since particular attention has been directed to the astronomy of comets, and since the number of observers have increased, scarcely a year has passed without the observation of one or two of these bodies, and sometimes even two or three have appeared at once. In the year 1825, no less than *four* comets made their appearance within the space of three months. The first of these was discovered by M. Gambart, at Mar-seilles, on May 9, in the head of *Cassiopeia*; the second by M. Valtz, at Nismes, on July 13, in *Taurus*; the third by M. Pons, at Florence, on

August 9, in *Auriga*; the fourth, or Encke's comet, about the month of July or August. But it is evident that multitudes must escape all observation, by reason of their paths traversing only that portion of the heavens which is visible in the daytime.

The number of comets whose paths have been particularly observed during their visible course is about 137. Of these sixty-nine moved in a *direct* course, or according to the order of the signs, as the planets do, and sixty-eight in a retrograde direction. As to the *distances of their perihelions* from the sun and the earth, thirty were found to have their perihelions between the orbit of Mercury and the sun; forty-four, between the orbits of Mercury and Venus; thirty-four, between the orbits of Venus and the earth; twenty-three, between the orbits of the Earth and Mars; six, between the orbits of Mars and Jupiter. Beyond the orbit of Jupiter no comets have been perceived; and it is seldom they can be seen beyond the orbit of Mars. As to the *inclination of their orbits*, nine comets have been observed whose orbits incline to the ecliptic from  $0^{\circ}$  to  $10^{\circ}$ ; thirteen, from  $10^{\circ}$  to  $20^{\circ}$ ; ten, from  $20^{\circ}$  to  $30^{\circ}$ ; seventeen, from  $30^{\circ}$  to  $40^{\circ}$ ; fourteen, from  $40^{\circ}$  to  $50^{\circ}$ ; twenty-three from  $50^{\circ}$  to  $60^{\circ}$ ; seventeen, from  $60^{\circ}$  to  $70^{\circ}$ ; nineteen, from  $70^{\circ}$  to  $80^{\circ}$ ; fifteen, from  $80^{\circ}$  to  $90^{\circ}$ . It appears, then, that these 137 comets had their orbits inclined in almost every degree to the ecliptic; and it is probable that this is the case with all the other comets which belong to the system.

Although comets generally emit an obscure light, yet some have been seen whose splendor was so great as to be visible in daylight, even at noon, and while the sun was shining in all its brightness. Such, it is said, were the comets which appeared in 1402 and 1532, and that which appeared a little before the assassination of Cæsar, and which was supposed, after that event happened, to have been an omen or prelude of his death. It has likewise been stated, that comets have appeared of such a magnitude as to have eclipsed the sun. Seneca relates that such a coincidence happened sixty years before Christ, when a large comet was actually observed very near the sun.\* The same author relates that a comet which appeared in the time of the Emperor Nero was not inferior in apparent magnitude to the sun himself;† and the comet which Hevelius observed in the year 1652 did not seem to be less than the moon, though it was deficient in splendor.

Comets traverse all parts of the heavens; and, as already noticed, their orbits have every possible inclination to the plane of the ecliptic. They are, however, governed in their motions by the same physical laws which regulate the motions of the planets. Their periodical times are to the periodical times of the planets, in the sesquiquiate ratio of their principal axes. Comets, therefore, being for the most part beyond the planetary regions, and on that account describing orbits with much larger major axes than the planets, revolve more slowly. Thus, if the major axis of a comet's orbit be four times as long as that of the orbit of Uranus, the time of the comet's period would be to that of the planet as 8 : 1; its periodic time would therefore be nearly 672 years; that is,  $8 \times 84 =$  the period of Uranus = 672. Although comets move with great rapidity when near their perihelion, yet in the remote parts of their course their motion must be proportionally slow.

The motions of comets when approaching the sun are in certain cases extremely rapid. The comet which was observed by Regiomontanus, in 1472, was said to have passed through 10 degrees of a great circle in twenty-four hours. Brydone, in his "Tour through Sicily," relates that he observed a comet at Palermo, in June and July, 1773, which moved through 50 degrees of a great circle in twenty-four hours. At midnight, on the 30th of June, it passed the zenith of Palermo (latitude  $38^{\circ} 10'$ ), and the next day, July 1, at 20 minutes past eight, P. M., it passed 4 degrees to the east of the polar star. He remarks that, "supposing it at the distance of the sun, at this rate of traveling, it would go round the earth's orbit in less than a week, which makes about eighty millions of miles a day,—a motion that vastly surpasses all human comprehension. And as this motion continues to be greatly accelerated, what must it be when the comet approaches still nearer to the body of the sun!" It is probable, however, that the comet was considerably nearer the earth than the distance of the sun; but still the velocity with which it was impelled must have been amazingly great.

Such is a brief summary of the most remarkable facts, interesting to the general readers, which have been ascertained in relation to comets. It is to be hoped that, in the progress of astronomical discovery, some additional light will be thrown on the nature and the destination of those mysterious bodies, whose number appears so far to surpass that of the primary and secondary planets of our system. It was long ago predicted by Seneca, a Roman philosopher who lived in the first century of the Christian era, "that the time will come when the nature of comets and their magnitude will be demonstrated, and the courses they take, so different from those of the planets; and that posterity will wonder that the preceding ages should be ignorant in matters so plain and easy to be known." In order that this prediction may be fully realized, it is requisite that we should become acquainted with all the observations that have hitherto been made, and the facts in relation to these bodies which have been ascertained; that we should compare the various observations with each other, and attend to the minutest circumstances and phenomena connected with comets; that numerous observers should be appointed to survey different portions of the firmament, both in the northern and southern hemispheres, that no comet that comes within the limits of our vision may pass unobserved; and that when a comet of large size approaches near the center of our system, every minute particular in reference to its motions, and the changes which take place in its nucleus, envelope, and tail, be carefully observed and delineated by accurate representations.

Whatever opinions we may adopt as to the physical constitution of comets, we must admit that they serve some grand and important purpose in the economy of the universe; for we cannot suppose that the Almighty has created such an immense number of bodies, and set them in rapid motion according to established laws, without an end worthy of his perfections, and, on the whole, beneficial to the inhabitants of the system through which they move.

They display the *wisdom of their Creator in the arrangements of their orbits and motions*. As we have every reason to conclude that at least thousands of those bodies traverse the solar system in all directions, and are certain that their orbits are inclined in every possible degree to one another, and to the orbit of the earth, so we find that they

\* Sir John Herschel's Astronomy.

† Dr. O. Gregory's Astronomy.



have been so admirably arranged by Divine Intelligence, that no one of them interferes with another, or with the courses of the planets, so as to produce concussion or disorder. The orbits of some comets indeed are found to approach very near, and even to cross the orbit of the earth and the orbits of several other planets, and consequently, there is a possibility that a comet might come into concussion with our globe; and this consideration shows us that we are dependent for our present security and comforts on the wise arrangements of the Almighty, in securing perfect harmony and order amidst apparent danger and confusion. But we have no evidence that such a catastrophe has ever happened, either in the case of the earth or of any of the other planets, or that one comet has ever impinged upon another. Believing that every object and event in the universe is arranged and directed by an Omnipotent Contriver, we must admit that when the Almighty formed the wondrous plan of creation, "foreseeing the end from the beginning," he arranged the periods and the velocities of comets in such a manner that, although occasionally crossing the planetary orbits, they should not pass these orbits at the time when the planets were in their immediate vicinity. And should such an event ever occur, we may rest assured that it is in perfect accordance with the plan and the will of Omnipotence, and that it is, on the whole, subservient to the happiness and order of the intelligent universe, and the ends intended by the Divine government. If there are thousands and perhaps millions of comets of all descriptions traversing every part of the planetary regions, in orbits of every degree of inclination, of extent, and of eccentricity, we are sure that none but a Being of infinite power and intelligence could have arranged such a vast and complicated system, so as to have prevented numerous interferences and disasters, and to make the whole move onward for ages in perfect harmony.

The system of comets likewise presents to us a display of the *omnipotence and grandeur of the Deity*. The number of these celestial visitors, the vast magnitude of their tails, envelopes, and nuclei, and the amazing velocity with which they wheel their courses through the ethereal regions, exhibit before us objects of astonishing grandeur, and evince the Almighty power of Him who at first impelled them in their rapid career. The diameter of the nucleus of the comet of 1807 was estimated by Schroeter at 4900 miles, and that of its coma 120,000 miles. Beside its principal tail, it shot forth comas to the extent of four millions, six hundred thousand miles. The nucleus of the comet of 1811 was, according to the same observer, 50,000 miles in diameter, its coma or envelope 947,000 miles, and its tail or train of light, sixty millions of miles in length, or more than half the distance between the earth and the sun. Let us conceive such a body, like the comet of 1680, traversing the immense spaces of creation with the velocity of ten hundred thousand miles an hour, and drawing after it a luminous train, a hundred millions of miles in length, approaching at one time so near the sun that his circumference would appear to fill the greater part of the firmament, and then rushing back through the depths of immeasurable space, thousands of millions of miles beyond the orbit of Uranus, and displaying its majestic train to the other planetary worlds of our system—and we have presented to our mental eye an object of peculiar grandeur and magnificence, different from everything else which the planetary system exhibits, and which displays in

an eminent degree the power and magnificence of the Great Creator. Were such a body to sweep along the regions which lie in the immediate vicinity of our globe, at the distance of ten or twelve thousand miles, nothing that we have ever beheld or can well conceive could be compared to the majestic grandeur of the scene, which would overpower the mind both with astonishment and with terror. On the view of such an object, sweeping along with such velocity, we could scarcely refrain from exclaiming, in the language of inspiration, "Great and marvelous are thy works, Lord God Almighty!" What, then, shall we think of thousands of such mysterious orbs winding their flight in every direction, in perfect regularity and order, through the immensity of space! Surely these are the wonderful works of Him who is mighty in operation and perfect in knowledge.

In all the works of the Deity, we must likewise admit that his *goodness* is displayed, although we may not be able to trace the mode of its communication; for we may lay it down as an axiom, that wherever wisdom and omnipotence are exhibited throughout the Divine economy, there is also a display of *benevolence*, which appears to be one prominent design of all the works of God. Comets have long been considered as objects of terror, and as omens of impending calamities; but there can be no question that they are as intimately connected with a system of benevolence as are the solar radiations and their benign influence on our globe and on the other planets. It has been conjectured that comets may supply moisture to the planets, and invigorate the vital principle of our atmosphere; that they may recruit the sun with fresh fuel and repair the consumption of his light; or that they may be the agents for dispersing the electric fluid throughout the planetary regions; and although there is little probability that such conjectures are accordant with fact, yet it may be admitted that comets may produce a *physical* influence of a beneficial nature throughout the solar system. But what I conceive to be one of the main designs of the Creator in the formation of such a vast number of splendid bodies is, that they may serve as habitations for myriads of intellectual beings, to whom the Almighty bestows his perfections in a peculiar manner, and on whom he displays the riches of his benevolence. Whatever may be the intention of those comets which are destitute of a nucleus, this, in all probability, is the chief design of those which are large and which are invested with a solid nucleus; and the same arguments which we formerly brought forward to prove that the planets are inhabited might be adduced in proof of the inhabitation of comets. If this position be admitted, then we ought to contemplate the approach of a comet, not as an object of terror or a harbinger of evil, but as a splendid world, of a different construction from ours, conveying millions of happy beings to survey a new region of the Divine empire, to contemplate new scenes of creating power, and to celebrate in loftier strains the wonders of Omnipotence.\* Viewing the comets in this light, what an immense population must be contained within the limits of the solar system, which gives room for the excursions of such a vast number of these bodies! and what an incalculable number of beings of all ranks must people the wide-extended universe!

\* The most complete account of the phenomena, &c. of comets I have seen is a treatise on this subject in manuscript, by the Rev. Thomas W. Webb, of *Tretire*, near *Russ*.



## APPENDIX.

### GENERAL APPEARANCE OF THE STARRY HEAVENS AT DIFFERENT PERIODS OF THE YEAR.

The following descriptions are intended to point out to the young observer the principal stars and constellations in the beginning of every alternate month throughout the year, and the particular quarter of the heavens where they may be perceived. The time of observation is supposed to be *nine o'clock in the evening*, except on the 1st of July; but the general aspect of the heavens, and the relative positions of the different stars and constellations, will not be materially different when viewed an hour before or after the time specified.

#### ASPECT OF THE HEAVENS ON THE 1ST OF JANUARY, AT NINE O'CLOCK IN THE EVENING.

At this time the *Pleiades*, or Seven Stars, are nearly on the meridian, at an elevation of more than 60 degrees above the southern horizon. The bright star *Aldebaran*, or the Bull's Eye, which is of a ruddy hue, appears to the left, in a direction nearly east by south, at the distance of 14°. About 15° east-north-east of Aldebaran is a bright star of the second magnitude, marked *Beta*, or

This treatise contains—1. A copious introduction, embodying a variety of interesting general remarks in relation to this subject. 2. A particular account of the comet of 1807, according to the observations of Sir William Herschel. 3. A description of the same comet from the observations of Dr. Johan. Hieronym. Schroeter. 4. An account of the great comet of 1811, according to the observations of Sir W. Herschel. 5. A particular description of the phenomena of the same comet, according to the observations of Schroeter. 6. A description of the second comet of 1811, according to the observations of Sir W. Herschel. These observations, particularly those of Schroeter, contain the most minute descriptions which have hitherto been given of the phenomena of this class of the celestial bodies, and will be found of essential service, not only to amateur observers, but to astronomers of every description. They have been extracted and arranged chiefly from the "Philosophical Transactions," and the works of Schroeter, which were published in the German language. The *Appendix*, or Second Part, which occupies nearly half the volume, comprises a lucid investigation of the following topics—1. Comparison of observations. 2. Examination of hypotheses. 3. Nature, light, and solidity of comets. 4. Colors of Comets. 5. Brightness of Comets. 6. Divided tails of Comets. 7. Comets of Comets. 8. Miscellaneous notices concerning remarkable comets. 9. On the influence of comets. 10. Losses to science, containing an account of the disasters which befell Schroeter, Hevelius, &c. 11. Hints to amateur observers. This volume contains 270 quarto pages, beside a great number of copious notes, and forty-six figures of the different appearances of comets. It indicates a very great degree of labor and research, which the astronomer alone will be able fully to appreciate. The author appears to have consulted most of the works which have been published on the subject, in the English, Latin, French, and German languages, beside embodying a number of original observations and remarks. And what is not among the least important features of the work, the author takes every proper opportunity of introducing such moral reflections as he subject naturally suggests, and of directing the contemplations of his readers to Him who sits on the throne of the universe. The observations of Schroeter contained in the preceding pages, have been extracted from this volume. It is to be hoped that the worthy author, who is already known to a considerable portion of the scientific world by his communications to *peripatetics* and *scientific association*, will soon receive encouragement to lay this work before the public.

*El-nath*; from this star to *Zeta*, in the tip of the southern horn of the Bull, is about 8° in a southern direction. This star forms a right angle with Aldebaran and Beta. North of Beta, at the distance of 17°, is the bright star Capella, in the constellation of Auriga, a star of the first magnitude, which appears at a high elevation a few degrees south-east of the zenith. In a direction south-east of Aldebaran and the Pleiades is the splendid constellation of *Orion*. *Bellatrix*, on the west shoulder of Orion, is about 16° south-east of Aldebaran, which is placed in the middle of the line which connects the Pleiades with Bellatrix; these three objects appearing nearly equidistant in a line N. W. and S. E. of each other. Nearly due east from Bellatrix, at the distance of 7½°, is Betelgeuse, a star of the first magnitude in the east shoulder of Orion. About 15° south by west of Bellatrix is *Rigel*, a star of the first magnitude in the left foot, and 8½° to the east is *Saph*, a star of the third magnitude in the right knee of Orion. These four stars in the form of a parallelogram, with the three bright equidistant stars called the *Belt*, form the outlines of this constellation. There is a small triangle of three small stars in the head of Orion which forms a larger triangle with Bellatrix and Betelgeuse, the two in his shoulders. (See fig. of Orion, p. 26, and Plate I.)

North-east of Betelgeuse, at the distance of 14°, is the star *Aliena*, or  $\gamma$  Geminorum, the principal star in the feet of the Twins; and about 20° N. E., nearly in the same right line from Betelgeuse, are *Castor* and *Pollux*, Castor being the uppermost and the brightest, at the distance of only 4½° from Pollux. These and the other stars which lie adjacent to them form the constellation Gemini, one of the signs of the Zodiac. The small stars immediately to the east of Gemini are in the constellation *Cancer*, another zodiacal constellation through which the sun passes in July and August. In this constellation is a nebulous cluster of very small stars, called *Præsepi*, which may be distinguished as a faint cloudy speck by the naked eye. (See page 63.)

Immediately below Orion are the constellations of *Lepus*, or the Hare, and Noah's Dove, which are very near the horizon. South by east of Orion is *Canis Major*, or the Greater Dog, which is distinguished by its principal star *Sirius*, the brightest fixed star in the heavens. It is nearly straight south of Alhena, in the feet of the Twins, at 35° distant, and south by east of Betelgeuse at the distance of 27°. A line drawn through the three stars in the belt of Orion, and prolonged, meets Sirius at the distance of 23°. About 5½° west of Sirius is *Mirzam*, of the second magnitude, in the foot of the Dog. Nearly due east from Orion, but less elevated above the horizon, is *Canis Minor*, or the Lesser Dog. The center of this small constellation is situated about 5° north of the equinoctial, and midway between Gemini and Canis Major. It is distinguished by the bright

star named *Procyon*, which signifies "before the Dog." About  $4^{\circ}$  to the north-west is *Gomelza*, a star of the third magnitude. *Procyon*, at the time supposed, appears nearly due east from Betelgeuse, at the distance of about  $26^{\circ}$ . The head of *Hydra* lies immediately to the east of *Procyon*; but *Alphard*, or *Cor Hydra*, the principal star of this constellation, is not risen at the time supposed. A little to the north of the eastern point of the compass, and at a very small elevation above the horizon, is *Regulus*, a star of the first magnitude, in the constellation *Leo*, which is the fifth sign, and the sixth constellation of the zodiac.

Turning our faces toward the north-east, *Ursa Major*, or the Great Bear, is the most striking constellation that meets the eye. The two pointers, *Dubhe* and *Merak*, appear uppermost, and point westward to the Pole-star; while the stars forming the tail seem to hang downward from the square of this constellation. As the night advances, this group of stars rises higher in the heavens, until, about three in the morning, they approach near the zenith. *Ursa Minor*, or the Lesser Bear, is seen below the pole, the square of which being a little to the eastward of the meridian. Directly below the Great Bear, at a very small elevation above the horizon, and in a direction N. E. by N., is *Cor Caroli*, a star of the second magnitude, in *Canis*, one of the Greyhounds. North by east of *Aldebaran*, at the distance of  $30^{\circ}$ , is the bright star *Capella* in *Auriga*.

Directing our view a little to the west of the meridian, we perceive the constellation *Aries*, which is immediately to the westward of the Pleiades, and nearly at the same altitude. Above 2000 years ago, in the days of Hipparchus, this constellation occupied the first sign in the zodiac, into which the sun entered about the 21st of March, but, as in consequence of the *precession of the equinoxes* the constellations gain about  $50'$  on the equinox every year, they have now advanced in the ecliptic nearly 31 degrees beyond it, or somewhat more than a whole sign; so that the constellation *Pisces* now occupies the same place in the zodiac that *Aries* did 2000 years ago, while the constellation *Aries* is now in the sign *Taurus*, *Taurus* in *Gemini*, &c., so that *Aries*, though the first sign, is the second constellation of the Zodiac. It is situated next east of *Pisces*, and midway between the *Triangles* and *Musca* on the north, and *Cetus*, or the Whale on the south. It is distinguished by two bright stars in the head, distant from each other about  $4^{\circ}$ , the brightest being a little to the east or north-east of the other, being about  $25^{\circ}$  west of the Pleiades, and  $19^{\circ}$  south of *Almaack*, in the foot of *Andromeda*. North by east from *Aries* is *Musca*, or the Fly, which consists of four or five stars, chiefly of the third and fourth magnitudes, very near to each other. It is situated between the first star of *Aries* and the Pleiades, but a little higher than either. North by east from the Fly, at the distance of about  $15^{\circ}$ , and at  $20^{\circ}$  north by west of the Pleiades, and at a higher elevation, is the head of *Medusa*, the principal star of which is *Algol*, which regularly varies in its luster. (See p. 41.) West by north from *Medusa* is *Andromeda*, one of the principal stars of which is *Almaack*, at the distance of  $12^{\circ}$  west by north of *Algol*. West of *Almaack*, at the distance of  $12^{\circ}$ , is *Mirach*, both of them stars of the second magnitude. If the line connecting *Almaack* and *Mirach* be prolonged  $8^{\circ}$  farther west or south-west, it will reach *Delta*, a star of the third magnitude, in the left breast.

West from *Andromeda*, and a little to the south,

is *Pegasus*, or the Flying Horse, which is distinguished from the other constellations by four bright stars of the second magnitude, forming a square, which is generally termed the *square of Pegasus*. The northernmost star, which is the brightest of three that form a kind of triangle, is *Scheat*, whose N. declination is  $26\frac{1}{2}^{\circ}$ . *Markab* is situated  $13^{\circ}$  south of *Scheat*, and at the time supposed is nearly due west, and about  $22^{\circ}$  above the western point of the horizon. These two stars form the western side of the square. East from *Markab*, at the distance of  $16\frac{1}{2}^{\circ}$ , is *Algenib*, and  $14^{\circ}$  north of *Algenib* is *Alpheratz*; which two stars form the eastern side of the square. *Scheat* and *Alpheratz* form the northern, and *Markab* and *Algenib* the southern sides of the square. *Alpheratz* constitutes a part of the head of *Andromeda*, but it is also considered as connected with *Pegasus*. About  $26^{\circ}$  north of *Andromeda* is *Cassiopeia*, midway between it and the Pole-star. It passes the meridian nearly in the zenith about the 22d of November. At this time it is between  $20^{\circ}$  and  $30^{\circ}$  west of the meridian. (See pp. 16 and 37.) The star *Caph*, in this constellation, along with *Alpheratz* and *Algenib*, are situated on the prime meridian which passes through the first point of *Aries*, from which the right ascensions of all the heavenly bodies are measured. The line connecting these stars forms an arc of the equinoctial colure, which passes through the vernal equinox, and across which the sun passes on the 21st of March. When we say that the sun, or a star, or a planet is in so many degrees of right ascension, we mean that it is situated, or has moved eastward so many degrees from this great circle. North-west of *Cassiopeia* is *Cepheus*, at the distance of about  $25^{\circ}$ , the head of which is in the Milky Way, and may be known by three stars of the fourth magnitude in the crown, forming a small acute triangle about  $9^{\circ}$  from *Alderamin*, a star of the third magnitude in the left shoulder.

Next to *Cepheus*, on the west, is *Cygnus*, or the Swan; the principal stars of which are distinguished as forming the figure of a large cross, the upright piece of which lies along the Milky Way. The most brilliant star in this constellation is *Deneb Cygni*, of the first magnitude, which is at this time in a direction nearly north-west, and  $25^{\circ}$  above the horizon. West from *Deneb*, at the distance of  $10^{\circ}$  or  $11^{\circ}$ , is *Delta*; and the line prolonged about  $15^{\circ}$  farther leads to the bright star *Vega*, the principal star in *Lyra*, which is then about  $6^{\circ}$  above the horizon in a direction north-west by north. North by east of *Lyra* is the head of *Draco*, distinguished by four stars separated from each other by intervals of  $3^{\circ}$ ,  $4^{\circ}$ , and  $5^{\circ}$ . The one to the south, or nearest *Lyra*, is *Eltanin*, or  $\gamma$  *Draconis*, which Dr. Bradley fixed upon in his attempt to determine the annual parallax. At this time it is  $16^{\circ}$  above the horizon, in a direction N. N. W. About  $4^{\circ}$  to the north of it is *Rastaben*, both of them stars of the second magnitude. Turning our eyes again toward the southern part of the meridian, we behold the head of *Cetus*, or the Whale, about  $20^{\circ}$  S. E. of *Aries*, and about  $24^{\circ}$  S. by W. of the Pleiades. It is distinguished by five stars,  $4^{\circ}$  or  $5^{\circ}$  asunder, which form a figure resembling a regular *pentagon*. The brightest of these stars, which is the easternmost, and of the second magnitude, is *Menkar*, which makes an equilateral triangle with *Arietis* and the Pleiades, being distant from each about  $23\frac{1}{2}^{\circ}$ . About  $14^{\circ}$  south-west of *Menkar* is *Mira*, or the Wonderful Star, which is found to vary its apparent size from a star of the second or third,

to one of the sixth or seventh magnitude. (See p. 41.) North-west of the head of Cetus, and west of Aries, is the constellation *Pisces*, or the Fishes, one of the signs of the Zodiac, in which there are no remarkable stars, most of them being of the third, fourth, and inferior magnitudes.

Such is the general outline of the heavens as they appear about the beginning of January.

GENERAL APPEARANCE OF THE HEAVENS ON THE 1ST OF MARCH, AT NINE O'CLOCK, P. M.

At this period of the year, at 9 p. m., several of the constellations which were seen in the beginning of January, have disappeared, such as *Pegasus*, *Pisces*, and others. Others, which are still visible, appear in other quarters of the heavens; and some stars and constellations which were then below the horizon have risen to a considerable elevation above it. Orion is now in the south-west quarter of the heavens; the Pleiades, instead of being on the meridian, are due west, at an elevation of  $34^\circ$  above the western point of the horizon; the bright star *Sirius* is to the west of the meridian, in a direction S. S. W.; *Canis Minor* and *Procyon* are a few degrees to the west of the meridian; *Castor* and *Pollux*, directly north of *Procyon*, have likewise passed the meridian; *Capella* is seen at a high elevation,  $39^\circ$  west of the zenith; *Menkar*, in the head of the Whale, is within a few degrees of the western horizon; *Aries* is likewise near the western horizon; and *Cassiopeia* is in a north-westerly direction, and at a lower altitude than in January; *Deneb*, in the Swan, is very near the horizon, a little to the west of the north point; *Vega*, in the Lyre, is just rising at a short distance to the east of it; the head of *Draco* is in a N. N. E. direction, about  $18^\circ$  above the horizon; the Great Bear is at a higher elevation than in January, and the Pointers in a direction N. N. E.; and *Cor Caroli* appears in a direction east by north, about midway between the zenith and the horizon.

The following constellations, among others, now appear, which were under the horizon in January.—*Hydra*, the largest star in which is *Alphard*, or *Cor Hydræ*. It is at this time in a direction S. S. E., about  $2^\circ$  above the horizon. It may be distinguished from this circumstance, that there is no other considerable star near it. It is  $23^\circ$  S. S. W. of *Regulus*. The constellation *Leo*, which was only partly visible in January, now appears in its splendor toward the eastern part of the sky. *Regulus*, one of its largest stars, situated within half a degree of the ecliptic, is distinguished as being the largest and lowest of a group of five or six stars which form a figure or curve somewhat resembling a sickle. East of *Regulus*, at a distance of  $25^\circ$ , is *Denebola*, in the Lion's tail, which appears nearly in an eastern direction  $35^\circ$  above the horizon. East from *Leo* is the constellation *Virgo*; but all the stars connected with it have not at this time risen above the horizon. It is situated midway between *Coma Berenices*, on the north, and *Corvus* on the south. *Coma Berenices*, which consists of a cluster of small stars, is in a direction nearly due east, and about midway between the zenith and the horizon. East by north of this cluster, at a low elevation, is *Bootes*, the principal star of which is *Arcturus*, of the first magnitude. It is at this time in a direction east by north,  $11^\circ$  above the horizon. Farther to the north, and at a lower elevation, is *Corona Borealis*, or the Northern Crown, the principal star in which is called *Alphacca*, of the third magnitude, and  $11^\circ$  east by north of *Mirac*,

or *Bootes*. This constellation is distinguished by six principal stars, which are so placed as to form a circular figure, somewhat resembling a wreath or crown.

GENERAL APPEARANCE OF THE HEAVENS ON THE 1ST OF MAY, AT 9, P. M.

At this period several of the more splendid constellations which adorn our nocturnal sky during winter have disappeared. Orion is nearly hid beneath the western horizon, and only the bright star *Betelgeuse* can be faintly seen, as it is about to descend below the western point of the horizon. *Aries* has completely disappeared; *Caput Medusæ*, *Taurus*, the Pleiades, and *Aldebaran*, are just verging on the borders of the north-western horizon, and are scarcely visible; and the brilliant star *Sirius* has completely disappeared from the nocturnal sky. The head of *Hydra*, with *Alphard*, its principal star, are in a south-westerly direction; *Canis Minor* and *Procyon* are in a direction W. S. W., considerably to the west of *Alphard*, but nearly at the same altitude. North of *Procyon*, at a considerable distance, are *Castor* and *Pollux*, about midway between the zenith and the western point of the horizon. At a considerable distance to the north-west of these is *Capella*, considerably nearer the north-western horizon than the zenith. *Cassiopeia* appears very low in altitude, near the northern quarter of the heavens, and the Great Bear appears near its most elevated position, not far from the zenith, the two Pointers pointing nearly directly downward toward the Pole-star, while at the same hour in November, they point almost directly upward. *Regulus* is about  $22^\circ$  west of the meridian, at a considerable elevation; *Denebola*, in the same constellation (the Lion), is just on the meridian, at a little higher altitude than *Regulus*. *Arcturus* is seen in a direction E. S. E., at a very considerable elevation, and  $26^\circ$  north-west of it is *Cor Caroli*, not very far from the zenith. The stars in the Northern Crown appear due east, midway between the zenith and the horizon. The brilliant star  $\alpha$  Lyre appears near the north-east, about  $23\frac{1}{2}^\circ$  above the horizon. The Swan is near the N. N. E. quarter of the sky, and one of its principal stars, *Deneb*, is about  $14^\circ$  above the horizon. The principal stars in *Draco* appear elevated  $20^\circ$  above  $\alpha$  Lyre, and nearly in the same direction.

The principal constellations which were formerly invisible are—the south-eastern portion of *Virgo*, *Libra*, *Taurus*, *Poniawski*, *Serpentarius*, and *Hercules*. These constellations appear near the eastern and south-eastern portions of the sky. The bright star of the first magnitude, *Spica Virginis*, which was below the horizon in March, is now elevated  $24^\circ$ , and may be seen in a direction S. S. E. It is  $35^\circ$  south-east of *Denebola*, and about the same distance S. S. W. of *Arcturus*; three stars of the first magnitude, which form a large equilateral triangle, pointing to the south. A similar triangle, pointing to the north, is formed by *Arcturus*, *Denebola*, and *Cor Caroli*. The principal star in *Hercules* is *Ras Algethi*; and *Ras Alhague*,  $5^\circ$  from it, in the head of *Ophiuchus*, may be seen nearly due east, at a small elevation above the horizon, *Ras Algethi* being the brightest and the highest. *Libra* is situated to the south of the *Serpent*, and to the east of *Virgo*. Its two brightest stars are of the second magnitude; the one is named *Zubeneshamali*,  $21^\circ$  east of *Spica Virginis*, but at a much lower altitude; the other is called *Zubenelgemabi*, about  $9\frac{1}{2}^\circ$  above the other toward the north-east. At this time they

appear in the south-east quarter of the heavens, at no great elevation above the horizon. The constellation *Serpens* lies between *Corona Borealis* and *Libra*. Its principal star is of the second magnitude, and named *Unuk*; it may be known by being nearly in the middle between two smaller stars, the lower one being  $2\frac{1}{2}^{\circ}$ , and the upper  $5\frac{1}{2}^{\circ}$  from it. It is in a direction E. S. E., at about  $24^{\circ}$  above the horizon.

ASPECT OF THE HEAVENS ON THE 1ST OF JULY, AT 10, P. M.

As the twilight at this season is too strong to admit of particular observations at 9 P. M., I have fixed the hour of *ten* as the most proper time for perceiving the principal stars. Most of the southern constellations which were visible in January, and which are the most brilliant, have now disappeared, and those in the north are in positions in the heavens very different from those on which they appeared in winter. The Northern Crown, the Serpent, and *Libra*, are now to the west of the meridian; *Arcturus* is now considerably to the west of the meridian, but at a high elevation; immediately below which, at a considerable distance, is *Spica Virginis*, very near the S.W. by W. point of the horizon. *Cor Caroli* appears north by west of *Arcturus*, at a considerable distance, and at a high altitude; immediately below which, at a considerable distance, and nearly due west, is *Denebola*. The Great Bear is now considerably west of the meridian, at a high altitude, the two pointers pointing eastward to the Pole-star. *Castor* and *Pollux* have just descended below the horizon near the north-west; and *Capella*, which never sets in this latitude, is very near the north point, only a few degrees above the horizon. *Cassiopeia* is near the north-eastern quarter, at no great elevation, and  $\alpha$  *Lyræ* is at a very high altitude to the east of the meridian; east of which, at a lower altitude, is *Deneb*, one of the principal stars in the Swan. The four stars forming the square of *Pegasus* are now seen a little to the north of the E. point, in a position nearly opposite to that in which they appeared in January. The star *Antares*, in *Scorpio*, of the first magnitude, is past the meridian, at an altitude of only about  $11^{\circ}$ . *Ras Algethi* and *Allhague* are nearly on the meridian.

The constellation of *Aquila*, or the Eagle, which was formerly invisible, now makes its appearance in the south-east. *Altair*, its principal star, of between the first and second magnitude, is distinguished by being nearly in the middle between two stars of the third magnitude, each of them  $2^{\circ}$  distant from it in a line bearing S. E. and N. W. *Altair* is at this time about  $37^{\circ}$  above the south-eastern horizon. North-east of *Aquila* is the *Dolphin*, at the distance of  $13^{\circ}$  or  $14^{\circ}$ . It is a beautiful little cluster of stars, consisting of about 18 in number, including five of the third magnitude, but none larger, which are so arranged as to form the figure of a diamond, pointing N. E. and S. W. It is sometimes known by the name of *Job's Coffin*. North and north-west of the *Dolphin* are *Sagitta*, and *Vulpecula et Anser*, or the Fox and Goose; south of *Aquila* is *Capricornus*, and south-east of it, *Aquarius*; but these last are more distinctly seen in the month of September. The Milky Way runs along with considerable brightness in the neighborhood of *Aquila*, *Vulpecula*, *Delphinus*, and *Cygnus*.

APPEARANCES OF THE SIDEREAL HEAVENS ON THE 1ST OF SEPTEMBER, AT 9, P. M.

At this time *Altair* is nearly on the meridian at

an altitude of  $46\frac{1}{2}^{\circ}$ , and *Vega*, or  $\alpha$  *Lyræ*, is about  $16^{\circ}$  west of the meridian, in a direction north by west from *Altair*. *Ras Algethi* and *Ras Allhague* are west from *Altair*, nearly midway between that star and the south-western point of the horizon. To the north-west of *Vega* is the head of *Draco*, at the distance of nearly  $20^{\circ}$ . *Arcturus* is in a position west by north, within  $19^{\circ}$  of the horizon. The Northern Crown is in a higher elevation than *Arcturus*, nearly due west, rather nearer the horizon than the zenith. *Cor Caroli* appears nearly N. W. by W. at  $23^{\circ}$  of altitude; and the Great Bear, in a north-westerly direction, and at a lower altitude than formerly. To the east of the meridian *Capella* is seen in a direction nearly N. N. E., at an altitude of  $15^{\circ}$ . East of *Capella*, at a little lower elevation, is *Menkalina*, or  $\zeta$  *Aurigæ*, a star of the second magnitude. *Cassiopeia* appears in the north-east, about midway between the zenith and the north-eastern horizon. The Square of *Pegasus* is in a direction east by south, and is in a much higher elevation than in July. The *Dolphin* is a few degrees east of the meridian, and N. E. of *Altair*, at an altitude of above  $50^{\circ}$ . Along the southern quarter of the heavens are the following constellations:—*Aries*, in a direction east by north; *Pisces*, due east, and next to *Aries* on the west; *Aquarius*, to the west of *Pisces*, in a direction S. S. E.; *Capricornus*, west from *Aquarius*, nearly in the south; *Sagittarius* and *Sobieski's Shield*, in a south-westerly direction, and *Scorpio*, which lies still farther to the west. Most of these constellations, except *Aries* and *Pisces*, are at a low altitude.

APPEARANCE OF THE HEAVENS ON THE 1ST OF NOVEMBER, AT 9, P. M.

About this time the winter constellations begin again to make their appearance in our hemisphere. The center of the Square of *Pegasus* is at this season and hour nearly on the meridian; the stars *Scheat* and *Markab*, of which *Scheat* is the uppermost, appear on the west of the meridian, and *Alpheratz* and *Algenib* on the east. Turning our eyes to the western part of the heavens, we see the *Southern Fish*, a little to the west of the south, and its principal star, *Fomalhaut*, several degrees to the west of the meridian, at a very low altitude. To the west is *Capricornus*, and to the north-west *Aquarius*. *Aquila*, with its principal star *Altair*, is in a direction west by south, at about  $23^{\circ}$  above the horizon. *Deneb Cygni* is at a very high elevation, about  $30^{\circ}$  degrees west from the zenith, and  $\alpha$  *Lyræ*  $26^{\circ}$  north-west of it, in a direction W. N. W., at a much lower elevation. North by west of *Lyræ* are the two stars in the head of *Draco*, *Eltanin* and *Rastoben*, about  $4^{\circ}$  apart. *Ras Algethi* and *Ras Allhague* are nearly due west, at a very small elevation above the horizon. The center of the Great Bear is nearly due north, and at its lowest elevation, the stars in the tail being to the west, and the two pointers a little to the east of the northern part of the meridian, pointing upward. Turning our view to the eastern quarter of the sky, we behold *Aries* in a south-easterly direction, next to *Pegasus*, and at a pretty high elevation. South by east of the first star in *Aries* is *Menkar*, in the head of the *Whale*, in a direction S. E. by E., about  $26^{\circ}$  above the horizon. North-west of the first star in *Aries* is *Mirach*, and north by east *Almaack*, at a higher elevation, both of them in *Andromeda*. Near the north quarter is *Capella*, about midway between the zenith and the horizon. The *Pleiades* are seen nearly due east, followed by the ruddy star

Alceoran, at a lower elevation. Below Aldebaran, and to the south-east, the head and shoulders of Orion begin to make their appearance, Bellatrix being  $4^{\circ}$  or  $5^{\circ}$  above the horizon, and Betelgeuse a little lower. Cassiopeia is near the zenith, a little to the east of the meridian, and Castor and Pollux, in Gemini, are in a direction north-east, just a little above the horizon. At this time the equinoctial colure is only a few degrees to the east of the meridian, and the three stars *Caph* in Cassiopeia, and *Alpheratz* and *Algenib*, in Pegasus, which lie in the line of its curve, may now be distinctly perceived. *Caph* is at the highest altitude of the three, and its distance from *Alpheratz* is about double the distance between *Alpheratz* and *Algenib*. If a line connecting these three stars be produced northward, it will terminate in the pole.

The above brief sketches may enable the young observer to trace the principal stars and constellations by a few observations at different seasons of the year. The altitudes here expressed are stated in reference to places about  $52^{\circ}$  north latitude; but by making certain allowances corresponding to the latitude of the observer, the relative positions of the stars will appear nearly the same as here represented, particularly if the difference of latitude does not much exceed 10 degrees. It should be carefully remarked that the bearings of one star from another, as here given, are strictly true only when the star from which the bearings are given is on or near the meridian. (See note, p. 70.)

As a further assistance to the astronomical tyro in distinguishing the stars, I have drawn up the following list of stars, chiefly of the first and second magnitudes, stating the periods of the year when they come to the meridian, or due south, at nine o'clock in the evening.

*Caph*, in Cassiopeia, and *Alpheratz* and *Algenib*, in Pegasus, come to the meridian on the 10th of November, at nine o'clock in the evening. *Caph* is near the zenith, and the other two at a considerably lower elevation. At this time *Capella* appears toward the north-east; the Pleiades, Aldebaran, and Orion, in the east; *Deneb* in Cygnus, in the north-west; *Lyra*, west-north-west; and *Altair*, in Aquila, west by south.

*Arctis*, or the first star of Aries, comes to the meridian on the 5th of December. The same stars noticed in the preceding instance are still visible, but those on the east of the meridian have risen to a higher altitude, and those on the west have descended to a lower elevation than on Nov. 10. *Castor* and *Pollux* are at this time seen toward the north-east, and *Procyon*, a very little above the eastern point of the horizon.

*Menkar*, in the head of the Whale, arrives at the meridian on the 21st of December, and at the same time the variable star *Algol*, in Medusa's head, which is  $37^{\circ}$  due north of *Menkar*. *Altair* has now disappeared from the west, and *Sirius* is seen at a small elevation in the south-east.

The Pleiades pass the meridian on the 1st of January, and Aldebaran on the 10th. When Aldebaran is due south, *Capella* is north by east of it, near the zenith; *Cor Caroli*, at a low altitude near the north-east; *Lyra*, near the horizon, N. by W.; *Regulus* in the east; and the head of *Hydra*, east by south.

*Bellatrix*, in Orion, passes the meridian on the 21st of January. Nearly at the same time *Capella* and  $\beta$  Aurigæ are on the meridian. These three stars are nearly equidistant in a line running north and south.

*Castor* and *Pollux* and *Procyon*. These three stars pass the meridian nearly at the same time, on the 24th of February. *Pollux* and *Procyon* culminate nearly at the same instant, and *Castor* about 11 minutes before them, at which time *Procyon* is  $23^{\circ}$  south of *Pollux*. Orion is then in a south-westerly direction; Aldebaran, midway between the meridian and the western horizon; *Menkar*, W. by S., at a small elevation; *Sirius*, S. by W.; and *Capella* to the west of the zenith. On the east of the meridian, *Regulus* is S. E.; *Denebola*, E.; *Cor Caroli*, E. N. E.; immediately below which, near the horizon, is *Arcturus*.

*Prosepe*, in Cancer, a small cluster of stars just perceptible to the naked eye, like a nebula, approaches the meridian about the 3d of March, at an altitude of about  $60^{\circ}$ . They are N. E. of *Procyon*, and S. E. of *Pollux*. (See pp. 63, 64.)

*Regulus*, in Leo, passes the meridian on the 6th of April. At this time, *Alphard*, in Hydra, is past the meridian S. by E. from *Regulus*; *Procyon*, S. W.; *Sirius*, S. W. near the horizon; Orion, very low in the west; *Algenib*, in Perseus, *Algol*, *Capella*, &c., toward the N. W. On the east, *Denebola* appears E. from *Regulus*; *Spica Virginis*, S. E., at a low altitude; *Cor Caroli*, E., at a high altitude; *Corona Borealis*, E. by N.; and *Lyra*, at a low altitude, N. E. by N. The Great Bear, at a high altitude, approaching the zenith, and *Cassiopeia*, at a low altitude toward the north.

*Denebola*, in Leo, culminates on the 3d of May, at an altitude of  $43^{\circ}$ . *Regulus* is  $25^{\circ}$  west of it, and *Phad*, in the square of the Great Bear, is  $39^{\circ}$  N. of it. It forms with these two a large right-angled triangle, the right angle being at *Denebola*. It is nearly on the meridian with *Phad*. Other stars then visible are — *Procyon*, W. by S.; *Capella*, N. W.; *Arcturus*, E.; *Spica Virginis*, S. S. E.; *Lyra*, N. E., &c.

*Coma Berenices*, a beautiful cluster of small stars, but scarcely distinguishable by moonlight, is on the meridian on the 13th of May. (See p. 63.)

*Spica Virginis* comes to the meridian on the 23d of May. Stars visible on the west—*Capella*, *Castor* and *Pollux*, and *Procyon*, near the western point. On the east—*Lyra*, *Arcturus*, *Ras Algethi*, *Ras Alhague*, and *Altair*, near the eastern horizon. Near the meridian, to the west—*Cor Caroli*, *Alloth* and *Mizar*, in *Ursu Major*.

*Arcturus* is on the meridian on the 23d of June. The principal stars in *Libra* culminate at a lower altitude about the beginning of July.

*Corona Borealis* is on the meridian about the 1st of July. Its principal star is eleven degrees east of  $\epsilon$  Bootes.

*Antares*, in *Scorpio*, passes the meridian on the 10th of July, at a very low altitude.

*Ras Algethi*, in *Ophiuchus*, and *Ras Alhague*, in *Hercules*,  $5^{\circ}$  apart, culminate about the 20th of July, nearly at the same time as the head of *Draco*.

*Vega*, or  $\alpha$  *Lyrae*, culminates on the 13th of August. To the west of it, at a great distance, is *Arcturus*, and to the north-west, *Cor Caroli*. *Capella* is N. by E., at a low altitude; *Altair*, S. S. E.; and *Deneb Cygni*, E., at a high altitude.

*Altair*, in Aquila, is at the meridian about the 30th of August, at an altitude of about  $46\frac{1}{2}^{\circ}$ .

*Arctid* or *Deneb Cygni*, is on the meridian on the 16th of September, at an altitude of  $82\frac{1}{2}^{\circ}$ . At this time *Arcturus* is W. S. W., near the horizon; *Lyra* and *Etaum*, in *Draco*, west from the meridian, but in a high elevation; *Cor Caroli*, N. W., at no great elevation; *Hercules*, S. W., midway between the meridian and the horizon; *Altair*, a little distance west of the S.; and the *Dei-*

plain on the meridian; the square of Pegasus in a south-eastern direction, Aries in the east, and Capella toward the north-east.

All the stars specified above, at the periods of the year stated, pass the meridian (or culminate) at nine o'clock in the evening. Therefore, if at any one of the periods of the year here specified, or a few days before or after it, an observer, at nine o'clock, p. m., observe the principal star or stars near the meridian, he can scarcely be at a loss to recognize them, as well as some of the other principal stars and constellations on the east and west of the meridian, which are also specified in the above descriptions. A person can never become familiar with the more prominent stars, the relative position of the different constellations, and the general aspect of the heavens, without actual observations. Even the delineations on the celestial globe will not convey an accurate and impressive conception of the scenery of the heavens, unless the study of these delineations be accompanied with frequent surveys of the heavens themselves. It is hoped the preceding descriptions will afford some assistance to those young observers and others who wish to contemplate the sublime objects of creation with their own eyes.

N. B. In the above and the following descriptions of celestial phenomena, *altitude* signifies the height of the star or planet above the horizon; S. S. E., south-south-east; N. by E., north-by-east, &c. Degrees are marked thus  $^{\circ}$ , minutes,  $'$ , seconds: thus,  $54^{\circ} 27' 35''$ , expresses fifty-four degrees, twenty seven minutes of a degree, and thirty-five seconds. Every degree contains 60 minutes, every minute 60 seconds, &c. When a heavenly body is said to *culminate*, the meaning is, that it has arrived at the highest point of its course, or its passage over the meridian. The term is derived from the Latin word *culmen*, the top or summit. An *occultation* signifies the obscuration of a star or planet by the interposition of the moon, or of another planet. *Conjunction* is when two or more stars or planets are in the same part of the heavens; and *opposition*, when they are  $180^{\circ}$  asunder, or in opposite parts of the heavens.

## PHENOMENA OF THE PLANETS FOR THE YEARS 1840 AND 1841.

### I. POSITIONS, ETC. OF THE PLANETS FOR 1840.

#### I. THE PLANET MERCURY.

This planet can be distinctly seen by the naked eye only about the time of its greatest elongation; and to those who reside in high northern latitudes it will scarcely be visible even at such periods, if it be near the utmost point of its southern declination.

The following are the periods of its greatest elongation for 1840: On the 8th of January it is at its western elongation, when it is  $23^{\circ} 19'$  west of the sun, and will be seen in the morning near the south-eastern part of the horizon; but as it is then  $21^{\circ} 45'$  in southern declination, and this declination every day on the increase, its position at that time will not be favorable for observation. Its next greatest elongation is on the 29th of March, when it will be  $18\frac{1}{2}^{\circ}$  degrees east of the sun, and be seen in the evening soon after sunset. This will form one of the most favorable opportunities of perceiving this planet by the naked

eye, or by means of a small opera-glass. Its declination being above nine degrees north, and on the increase, it will be distinctly seen for about ten days—namely, from the 16th to the 26th of March, a little to the north of the western point of the horizon, not far from the point at which the sun sets at that period. On the 5th of May, it will again reach its greatest western elongation, when it will be seen in the morning before sunrise. Its declination is then  $4\frac{1}{2}^{\circ}$  degrees north, and western elongation from the sun,  $26^{\circ} 18'$ . At this period, about four o'clock in the morning, it may be seen for more than three weeks—namely, from about the 20th of April to the 25th of May. Its direction will be nearly due east. This would form the most favorable opportunity of viewing this planet, were it not that the strong twilight at this season has a tendency to overpower its light.

In the month of July, if the long twilight do not prevent, there will be another favorable opportunity of inspecting this planet. During the whole of this month, Mercury will be at a considerable distance from the sun; but the best time for observation will be from the middle until the end of the month, as the twilight will then be less intense. It arrives at the point of its greatest eastern elongation on the 18th, when it is nearly  $27^{\circ}$  from the sun, and will be seen in the evening a little to the north of the western point of the compass, about forty minutes after sunset, or nearly nine o'clock, p. m. Its next greatest western elongation will be on the 1st of September, when it is  $18^{\circ} 5'$  west of the sun. At this period, it may be seen in the morning before five o'clock, in a direction nearly east-by-north, from the 27th of August to the 5th of September. On the 12th of November, it is at its next eastern elongation, when it will be seen after sunset near the south-western point of the horizon; but as its southern declination is at this time about 25 degrees, it will descend below the horizon nearly at the same time with the sun. The next elongation is on the 21st of December, when it is  $21^{\circ} 50'$  west of the sun, and will be seen in the morning between seven and eight, near the south-east quarter of the horizon.

The periods most favorable for detecting this planet in the evenings are, March 29th and July 18th; and in the mornings, May 5th and September 1st. During the interval of a week or ten days, both before and after the time of its greatest elongation, and sometimes for three or four weeks in succession, when in high north declination, this planet may generally be seen in a clear sky when in such favorable positions as these now stated. In those regions of the globe which lie south of the equator, the planet will be in the most favorable position for observation when in south declination.

#### II. THE PLANET VENUS.

This planet, like Mercury, is seen alternately, in the evening toward the western quarter of the heavens, and in the morning toward the eastern quarter. In its luster it exceeds all the other stars and planets, and its brilliancy is such that it can scarcely be mistaken by any observer when its position in the heavens is pointed out.

Venus will be seen only in the morning from the beginning of the year until the end of July. During the months of January, February, and March, it will be seen before sun-rise, chiefly in the south-eastern quarter of the heavens. Throughout April, May, June, and July, it will be seen in

the eastern and north-eastern parts of the heavens. During the whole of this period, it will appear, when viewed with a telescope, either as a half-moon or with a gibbous phase. Its superior conjunction with the sun happens on the morning of the 25th of July, after which it becomes an evening star; but it will not be much noticed by common observers until about the beginning or middle of September, on account of its proximity to the sun. From this period it will continue to be seen in the evening chiefly in the south-western part of the sky, at a low elevation, until the end of the year. On the whole, this planet will not be very conspicuous during 1849, either to the eye of a common observer or for telescopic observation. From the beginning of September to the end of December, it will exhibit a gibbous phase, like the moon about three or four days before the full.

Venus will be in conjunction with Saturn on the 22d of January, at 2h. 8', p. m., when it will be 57' north of Saturn. It will be in conjunction with Mars on the 16th of June, at sixteen minutes past three in the morning, when Mars will be 46' north of Venus; and it will be in conjunction with Jupiter on the 22d of October, at 8h. 34', p. m., when it will be 1° 6' south of that planet.

### III. THE PLANET MARS.

This planet will not be very conspicuous during this year on account of its great distance from the earth, and its proximity to that part of the heavens in which the sun appears. It is in conjunction with the sun on the 4th of May, after which it will be a considerable time before it becomes conspicuous to the unassisted eye.—Throughout the months of August and September, and the latter part of July, it will be seen early in the morning, before sun-rise, near the north-eastern quarter of the heavens. From September until the end of the year, it will appear somewhat more conspicuous, but not exceeding in apparent size a star of the third magnitude. On the 1st of October it comes to the meridian at six minutes past nine in the morning, at an altitude of 52<sup>2</sup>/<sub>3</sub>° above the southern horizon. On the first of November, it passes the meridian at fourteen minutes past eight in the morning, at an altitude of about 46°; and on the 1st of December, it transits the meridian at nineteen minutes past seven in the morning, at an altitude of 39<sup>2</sup>/<sub>3</sub>°. At this time (1st of December), it rises nearly due east about one in the morning, and will be pretty distinguishable on account of its ruddy aspect about an hour before sunrise.

### IV. THE PLANETS VESTA, JUNO, CERES, AND PALLAS.

These planets are not perceptible by the naked eye. The best time for observing them with telescopes is when they are at or near the period of opposition to the sun, when they are nearest the earth. Even then it will be sometimes difficult to detect them without the assistance of transit or equatorial instruments.

Vesta will be in opposition on the 18th of May, when it will pass the meridian at midnight, at an elevation above the horizon of 27° 54<sup>1</sup>/<sub>2</sub>'. Its right ascension is then 15h. 51' 55<sup>1</sup>/<sub>2</sub>", and its declination, 16° 25<sup>1</sup>/<sub>2</sub>' south. This planet will be in conjunction with the star  $\zeta$  Librae on the first of March, at twenty-seven minutes past five in the morning, the star being 55' north of Vesta; it will likewise be in conjunction with the same star on the 15th of May, at noon, when the star will be

29' south of the planet. On the 19th of July, at six in the morning, it will be in conjunction with  $\gamma$  Librae, when the star will be only one minute south of the planet, so that they will both appear in the same field of the telescope. On the 26th of August, at nineteen minutes past eight, a. m., it will be in conjunction with  $\gamma$  Scorpio, when the star will be only 11' south of Vesta. On September 3d, at eight in the evening, it will be in conjunction with  $\downarrow$  Ophiuchi, the star 11' north of the planet. On the 2d of October, at half-past one in the morning, it is in conjunction with Saturn, being 1° 2' south of that planet; and on the 6th of December, at ten minutes past one in the morning, it is in conjunction with Venus, Vesta being only 11' north of Venus.

Pallas will be in opposition to the sun on the 5th of July, at thirty minutes past nine in the evening. Right ascension, 18° 44' 52"; north declination, 22° 11' 57". It will pass the meridian about midnight, at an altitude of about 60° 11<sup>1</sup>/<sub>2</sub>'.

Ceres will be in opposition July 17th, at six in the morning. Right ascension, 19° 54'; south declination, 30° 8'. It will pass the meridian at an elevation somewhat less than 8°.

Juno will not be in opposition to the sun during 1840.

That the best time for observing these bodies is at the period of their opposition will appear from the following consideration:—that they are between two and three times nearer the earth at the time of opposition than when near the period of their conjunction with the sun; for example, Vesta is 225 millions of miles distant from the sun, and consequently only 150 millions distant from the earth at the time of opposition; but at the conjunction, it is the whole diameter of the earth's orbit=190 millions of miles, farther distant,—that is 320 millions of miles, which is a distance about two and a half times greater than when it is in opposition.

### V. THE PLANET JUPITER.

During the months of January, February, March, and April, this planet will be seen chiefly in the morning. About the beginning of February, it will rise in a direction south-east by east, about half-past one in the morning, and will come to the meridian at a quarter past six in the morning, at an elevation of about 22° above the southern horizon. On the 1st of March, it will rise about eight minutes before midnight, and pass the meridian about half-past four in the morning. On the 1st of April, it will rise at forty-three minutes past nine in the evening, and pass the meridian at a quarter past two in the morning. It will be in opposition to the sun, and consequently nearest the earth, on the 4th of May, when it will rise between seven and eight in the evening. From this period until the middle of November, when it is nearly in conjunction with the sun, it will be visible as an evening star, when it will be seen at different periods, chiefly in the south-eastern, the southern, and south-western parts of the heavens, at a comparatively low altitude; but it will not be much noticed by the naked eye after the end of September on account of its southern declination, which, for a considerable time, will be gradually increasing. Toward the end of December, it will again be seen in the morning near the south-eastern quarter of the horizon. The best time for telescopic observations on this planet will be from the beginning of April until the beginning of September.

Jupiter will be in conjunction with the star

$\alpha 2$  Libræ on the 15th of May, at forty-three minutes past three in the morning, when the star will appear one degree south of Jupiter; and on the 27th of August, at a quarter past two in the morning, it will be in conjunction with the same star, when it will be  $34'$  below Jupiter. On the 21st of November, at 4h.  $34'$ , p. m., it is in conjunction with the sun. On March 5th, at three in the morning, all the satellites of Jupiter will be on the east of that planet, when viewed with a telescope having an erect eye-piece, and in the order of their distances from Jupiter. The same phenomenon will happen on the 8th of June, at thirty minutes past eleven in the evening; on the 1st of August, at half-past eight in the evening; on the 27th of August, at the same hour, but on the west of Jupiter; on the 20th of September, at seven, p. m., on the east of Jupiter; and on the 16th of October, at six, p. m., on the west of Jupiter.

This planet can scarcely be mistaken, even by a common observer, when the quarter of the heavens in which it is visible is known, as it is next to Venus in apparent magnitude and splendor. It will appear most brilliant about the end of April and the beginning of May.

#### VI. THE PLANET SATURN.

This planet was in conjunction with the sun on the 6th of December, 1839; and therefore it will not be before the month of February this year that it will be in a favorable position for telescopic observation. During the months of February, March, and April, it will be seen only in the morning before sunrise, in the south-eastern quarter of the heavens, at a comparatively low altitude. On the 1st of February, it rises at half-past four in the morning, and comes to the meridian about half-past eight, at an elevation of about  $16\frac{1}{2}^{\circ}$ . On the first of March, it rises at forty minutes past two in the morning; on the 1st of April, at forty-two minutes past twelve, midnight; and on the first of May, it rises at forty minutes past ten in the evening. It is in opposition to the sun on the 8th of June; after which it will be seen in the evening. During the greater part of the month of May, it will likewise be seen between ten in the evening and midnight, but at a low altitude. It will continue to be visible until the month of December, but it will be difficult to distinguish it after the month of October, on account of its low altitude and its proximity to the sun. It arrives at the point of its conjunction with the sun on the 15th of December. The most favorable times and positions for taking telescopic views of this planet will be during the months of May, June, July, August, and September, especially when it is on or near the meridian. During the latter part of August and the months of October and November, about an hour after sunset, it will be seen toward the south-western quarter of the heavens, at a comparatively small elevation above the horizon.

This planet is not distinguished for its brilliancy to the naked eye; but it exhibits a most striking and beautiful appearance through a good telescope; more so than any other planet of our system. It appears of a dull leaden color when viewed by the naked eye, and is not easily distinguished from a fixed star except by the steadiness of its light, never presenting a twinkling appearance as the stars do; and from which circumstance it may be distinguished from neighboring stars. It will be in conjunction with the star *Rho* Ophiuchi on the 5th of June, at 51 minutes past 8, p. m.,

when the star will be about half a degree north of the planet. It will likewise be in conjunction with the same star on the 27th of October, at 9h.  $26'$ , p. m., when the star will be fifty-four minutes of a degree north of the planet. During this year the rings of Saturn will appear to the greatest advantage, the openings of these rings being then at their utmost extent. In the beginning of October, the proportion of the longer axis to the transverse axis of the rings is nearly as 35 to 16.

#### VII. THE PLANET URANUS.

This planet is for the most part invisible to the naked eye. The best time for detecting it by means of a telescope is when it is at or near the period of its opposition to the sun, which happens this year on the morning of the 11th of September. At that time it passes the meridian about midnight, at an elevation of about  $32\frac{3}{4}^{\circ}$  above the horizon. On the 1st of August, it passes the meridian at forty minutes past two in the morning; on the 1st of October, at thirty-two minutes past ten in the evening; on the 1st of November, at twenty-seven minutes past eight; and on the 1st of December, at twenty-eight minutes past six, in the evening. Its right ascension, or distance from the first point of Aries at its opposition, September 11, is  $23h. 18'$ ; and its south declination  $5^{\circ} 20' 26''$ . It rises during the year at points a little to the southward of the eastern point of the compass. It is in conjunction with the moon on the 9th of January, at 2h.  $17'$ , p. m., when it is  $1^{\circ} 27'$  south of the moon. It is in conjunction with Mars on the 16th of February, at 11h.  $33'$ , p. m., when Uranus is only nine minutes of a degree to the north of Mars; so that the two planets would be seen at the same time in the field of the telescope, were not both these bodies rather too near the sun at that time for distinct observation. It is in conjunction with the sun on the 6th of March, and with the moon on the 31st, when it is  $2^{\circ} 1'$  south of the moon. It is in conjunction with Venus on the 6th of April, at seven in the morning, when it is  $40'$  north of Venus. On the 25th of May, at forty-five minutes past nine in the evening, it is in conjunction with the moon, when it is  $2^{\circ} 39'$  south of that luminary. On the 15th of August, at 3h.  $15'$ , p. m., it is again in conjunction with the moon, when it is  $3^{\circ} 9'$  south of that luminary. On the 11th of September, at 8h.  $42'$ , p. m.; and on the 9th of October, at four in the morning, it is in conjunction with the moon, and in both cases it is then about  $3^{\circ}$  south of the moon.

N. B. In the preceding statements, the observer is supposed to be in  $52^{\circ}$  north latitude. In places a few degrees to the north or south of this latitude, a certain allowance must be made for the times of rising and the altitudes which are here specified. To those who reside in lower latitudes than  $52^{\circ}$  the altitudes of the different bodies will be higher, and to those in higher latitudes the altitudes will be lower than those which are here specified. For example; when it is stated that Saturn comes to the meridian at an altitude of  $16\frac{1}{2}^{\circ}$ , this planet will pass the meridian of a place in  $42^{\circ}$  N. latitude, at an altitude of  $26\frac{1}{2}^{\circ}$ , and the meridian of a place in  $62^{\circ}$  N. latitude, at an altitude of only  $6\frac{1}{2}^{\circ}$ . There being  $10^{\circ}$  of difference in the latitude of the supposed places, the altitude of the heavenly body will be  $10^{\circ}$  higher in the one case, and  $10^{\circ}$  lower in the other.



II POSITIONS OF THE PLANETS FOR 1841.

I. MERCURY.

This planet is at its superior conjunction with the sun on the 5th of February, and at its greatest elongation on the 4th of March, when it is 18° 8' east of that luminary; it will therefore appear as an evening star, in a direction nearly due west, a little above the horizon, after sunset, between six and seven in the evening. It arrives at its inferior conjunction with the sun on the 20th March. Its next greatest western elongation happens on the 17th of April, when it is 27° 21' west of that luminary. The planet will be seen about ten or twelve days before and after this time in an easterly direction, between three and four in the morning. Its next superior conjunction is on the 26th of May; and its next greatest eastern elongation, on the 30th June, when it is 25° 49' east of the sun, and consequently will be visible in the evening, in a north-westerly direction, after sunset. This would form one of the most favorable opportunities of seeing this planet, as it is then in a high north declination, were it not that the strong twilight at this season prevents small objects in the heavens from being easily distinguished. Its next greatest elongation is on August 15th, when it is 18° 37' west of the sun, when it will be seen in a north-easterly direction, about four in the morning. It is again at its greatest eastern elongation on the 25th of October, when it is nearly 24° east of the sun. It will be near the south-western part of the sky about sunset; but its great southern declination, at that period, will prevent it from being easily distinguishable. On the 3d of December, it will reach the point of its greatest western elongation, when it is 29½° west of the sun, when it may be seen for a week before and after this time, about seven in the morning, in a direction a little to the north of the south-east point of the compass, at low altitude.

II. VENUS.

Venus will this year exhibit a more frequent

and brilliant appearance to common observers than in 1840. It will be an evening star, first in the south-western, next in the western, and afterward in the north-western quarter of the heavens, during the months of January, February, March, April, and the beginning of May. During the greater part of January, it will appear nearly in a south-westerly direction, and W. S. W. Throughout February, it will appear nearly west, and west-by-north. Throughout March, April, and the beginning of May, it will be seen in a north-westerly direction, will be visible in a pretty high elevation above the western horizon, and will continue for the most part nearly three hours above the horizon after sunset. Its greatest brilliancy is about the 8th of April, when it appears in a crescent form. When viewed by the telescope in January, it will present a gibbous phase, like the moon four or five days before or after the full. In February and March it will be in the form of a half moon; in April and the beginning of May, it will assume the figure of a crescent; this crescent will appear more and more slender, but more expansive, until within a few days of its inferior conjunction with the sun, which takes place on the 15th of May, about one in the morning. After this period, this planet will be seen by the naked eye only in the morning before sunrise, in an easterly and north-easterly direction, until the end of the year; but with an equatorial telescope it may be distinctly seen every clear day, even at noon, during its whole course from one conjunction to another, with the exception of only two or three weeks in the course of nineteen months. Its greatest brilliancy after passing its inferior conjunction, is about the 20th of June; previous to which it will appear as a crescent, and will afterward gradually assume a half moon and a gibbous phase.

Venus, in its course throughout this year, will pass very near some of the other planets and some of the fixed stars. The following table exhibits the times and circumstances of those conjunctions in which Venus makes the nearest approach to some of these bodies.

In the following table, the first column states the

Time of conjunction.		Star in conjunction.		Relative position
		h. m.		
1.	Jan. 12	11 11	A.M. $\sigma$ Aquarii	* 0° 15' N.
2.	— 25	1 25	A.M. Uranus	Ura. 0 4 N.
3.	Feb. 18	7 46	A.M. $\epsilon$ Piscium	* 0 3 N.
4.	March 22	0 11	A.M. $\epsilon$ Arietis	* 0 8 N.
5.	April 7	6 56	A.M. $e$ Pleiadum	* 0 51 S.
6.	— 23	6 31	P.M. The Moon	Ven. 0 59 N.
7.	July 12	7 43	A.M. $\delta$ Tauri	* 0 11 S.
8.	— 12	3 52	P.M. $\beta$ Tauri	* 0 20 S.
9.	— 13	1 4	A.M. $\delta$ Tauri	* 0 6 N.
10.	— 24	3 40	A.M. $m$ Tauri	* 0 46 S.
11.	— 31	11 15	A.M. $\zeta$ Tauri	* 0 57 N.
12.	August 4	9 25	A.M. $\chi^1$ Orionis	* 0 14 S.
13.	— 6	1 26	P.M. $\chi^5$ Orionis	* 0 30 S.
14.	— 12	3 53	A.M. $\nu$ Geminorum	* 0 35 S.
15.	— 19	7 12	P.M. $\zeta$ Geminorum	* 0 4 S.
16.	Sept. 10	2 45	A.M. $\delta$ Cancri	* 0 38 N.
17.	— 12	7 50	A.M. The Moon	Ven. 0 21 .
18.	— 28	0 13	A.M. $\alpha$ Leonis	* 0 5 S.
19.	Oct. 3	7 35	A.M. $\delta$ Leonis	* 0 43 S.
20.	— 10	9 2	A.M. $\chi$ Leonis	* 0 15 N.
21.	— 13	9 56	P.M. $\sigma$ Leonis	* 0 29 N.
22.	— 26	9 42	P.M. $\nu$ Virginis	* 0 14 S.

time of conjunction of the star or planet with Venus; the second column contains the same star or planet; and the third, the distance and position of the star or planet from Venus. N. denotes that

the star is north of Venus; and S., that it is south A. M. denotes before twelve at noon; and P. M., after-noon. In those conjunctions marked Nos. 1, 2, 3, 4, 8, 9, 12, 15, 17, 18, 20, 22, the star and

the planet will be seen in the same field of view of the telescope; and although the observation should require to be made in the day-time, the star may probably be distinguished if the telescope have a great magnifying power. The conjunction of Venus with *Uranus* on the 25th of January, at twenty-five minutes past one in the morning, will afford an opportunity to amateur observers of observing this latter planet, which is invisible to the naked eye. Although both these bodies will be set to the inhabitants of Britain before the conjunction takes place, yet they will be both seen in the same field of the telescope between six and eight o'clock on the preceding evening, and they will not be far distant on the evening immediately succeeding the conjunction. At New York, Philadelphia, Boston, and other parts of the United States, these planets will be seen about an hour or an hour and a half before the time of conjunction. Uranus appearing very near Venus, and uppermost, when viewed with a telescope having an erect eye-piece.

N. B. All the above and the preceding and following statements are calculated for the meridian of Greenwich, and are expressed, not in *astronomical*, but in *civil* time.

### III. MARS.

During this year this planet will make a conspicuous appearance, and be seen in its brightest lustre; but its declination being *south* throughout the year, it will not rise to so high an altitude, nor remain so long above the horizon, as in some former years. During the months of January, February, and March, it will be seen only or chiefly in the morning, in a south-easterly direction. In the beginning of January, it will appear nearly in a direction east by south, soon after the time of its rising. On February the first, it comes to the meridian about five in the morning, at an altitude of about  $29^{\circ}$ ; and on March the first, at thirty-seven minutes past three in the morning, at an altitude of  $27^{\circ}$ . About the middle of March, it will rise about half-past nine in the evening, and may be seen about an hour or two afterward near the south-west quarter of the heavens. From this period, it will be seen in the evening, until the end of the year; but as its distance from the earth will rapidly increase after the months of August and September, and as it is then in a high degree of south declination, it will not be much noticed by common observers during October, November, and December. On the 18th of April, about two in the morning, it arrives at the point of its *opposition* to the sun, when it is nearest the earth, when it appears with a full enlightened hemisphere, and when it affords the best opportunities for telescopic observation. It will be most conspicuous this year in the evening, during March, April, May, June, July, and August, and will be distinguished from surrounding stars by its *ruddy* appearance. During the months of July, August, and September, it will be seen chiefly near the south-western portion of the sky. On the 11th of March it is *stationary*; that is, appears without any apparent motion; after which, its motion is *retrograde*, or contrary to the order of the signs of the Zodiac, and so continues until the 23rd of May, when it is again stationary; after which its motion is *direct* or according to the order of the signs.

The planet Mars will be in conjunction with  $\beta$  Virginis on the 1st of January, at thirty-two minutes past four, p. m., when the star will be  $17''$  south of the planet. It will be in conjunction

with  $\chi$  Virginis on the 4th of April, at eight o'clock in the morning, when the star will be  $49'$  north of Mars. It will be in conjunction with  $\alpha$  Librae on the 10th of August, at nineteen minutes past two, p. m., the star  $1^{\circ} 55'$  north. On the 16th of September, at fifty-three minutes past three in the morning, the star  $\gamma$  Ophiuchi will be in conjunction, at the distance of only  $1'$  to the south; so that the two bodies will seem almost to touch each other. On the 27th of September, about six o'clock in the evening, this planet will be in conjunction with Jupiter, when Mars will appear  $2' 4''$  to the south of Jupiter. On the 4th of October, at thirty-five minutes past ten, p. m., it will be in conjunction with  $\delta$  Ophiuchi, when the star will appear only  $6'$  south of the planet. On December 18th, it will be in conjunction with  $\gamma$  Capricorni, at  $2h 47'$ , p. m., when the star will be only eight minutes of a degree south of Mars.

### IV. VESTA, JUNO, CERES, AND PALLAS.

These planets will all be in opposition to the sun this year. *Vesta* will be in opposition on the 22d of October, at twenty-one minutes past three in the morning. It will transit the meridian about midnight, at an altitude of  $38^{\circ} 20'$ . Right ascension,  $2h. 2' 27''$ ; north declination,  $29^{\circ} 25''$ . On the 20th of April, at  $1h. 25'$ , p. m., it is in conjunction with the star  $\rho$  Piscium, the star  $1^{\circ} 34'$  north of the planet. On the 22d of April, at  $10h. 56'$ , a. m., it is in conjunction with  $\gamma$  Piscium, the star  $1^{\circ} 11'$  south of Vesta. On the 24th of August, at  $1h. 44'$ , a. m., the star  $\gamma$  Ceti will be in conjunction, the star  $14'$  north of Vesta; both these bodies will therefore be seen in the same field of a telescope.

*Juno* will be in opposition on the 19th of March, at  $2h. 45'$ , p. m., and will come to the meridian about midnight, at an altitude of  $41^{\circ} 3'$ . Right ascension,  $11h. 59' 55''$ ; north declination,  $3^{\circ} 3' 15''$ . Juno will be in conjunction with  $\gamma$  Virginis on the 1th of March, at  $3h. 24'$ , p. m., the star  $28'$  south of Juno. On the 25th of April, at noon, it will be in conjunction with  $\gamma$  Virginis, when the star will be only  $7'$  north of the planet. This conjunction will afford a favorable opportunity for detecting Juno. On the 24th of May, at  $7h. 12'$ , a. m., it will again be in conjunction with  $\gamma$  Virginis, when the star will be  $56'$  south of the planet. On the 22d of June, at  $5h. 39'$ , a. m., it will be in conjunction with  $\pi$  Virginis, the star  $45'$  north of the planet.

*Pallas* is in opposition to the sun on the 4th of September, at  $5h. 34'$ , p. m., when it will come to the meridian at an altitude of  $40^{\circ} 41' 3''$ . Right ascension,  $22h. 37'$ ; north declination,  $2^{\circ} 41' 20''$ . Pallas will be in conjunction with the star  $\alpha$  Aquarii on the 20th of September, about one in the morning, when the star will be  $22'$  south of Pallas.

*Ceres* is in opposition on October 13th, at twenty-two minutes past eleven, a. m., and comes to the meridian at that time at an elevation above the southern horizon of  $32^{\circ} 45' 2''$ . Right ascension,  $1h. 35' 29''$ ; north declination,  $5^{\circ} 14' 30''$ .

### V. JUPITER.

This planet passed its conjunction with the sun on the 21st of November, 1849, and will appear as a *morning* star during the months of January, February, March, and April. On the 1st of January, it will rise near the south, at thirty-four minutes past five in the morning, and will pass the meridian at forty minutes past nine, at an altitude

of nearly 17°. On the 1st of February, it will rise in the same quarter, at fifty-six minutes past three, and come to the meridian about eight. On the 1st of March, it will rise at twenty-two minutes past two in the morning, and pass the meridian at twenty-eight minutes past six. On the 1st of April, it rises at twenty-eight minutes past twelve, midnight; and on the 1st of May, at thirty-two minutes past ten in the evening; after which it will continue to be seen in the evening until about the middle of November. It will be in conjunction with the sun on the morning of the 23d of December, after which, it will be a morning star. The declination of Jupiter on January 1st is  $21^{\circ} 31\frac{1}{2}'$  south, and on the 1st of December,  $23^{\circ} 13\frac{1}{2}'$  south. On account, therefore, of its great southern declination, its altitude will be low, and its duration above the horizon comparatively short. Its altitude, when passing the meridian about the beginning of December, is only  $14^{\circ} 46'$ . Its opposition to the sun happens on the 5th of June, at 10h. 16', p. m. It will appear chiefly in a southerly and south-westerly direction in the evenings of July, August and September. The best time for telescopic observations on this planet, in the evening, will be from April until the end of August.

On the 26th of April, at a quarter-past three in the morning all the satellites of Jupiter will appear on the west side of the planet, when viewed with a telescope having an erect eye-piece, and in the order of their distances from Jupiter. The same phenomenon will happen on the 8th of June, at thirty minutes past eleven in the evening. On the 5th and 18th of July (on the east of Jupiter), at forty-five minutes past nine in the evening; on the 27th of September, at 7h. 30', p. m.; and on the 17th of November, at 5h., p. m.

#### VI. SATURN.

This planet will be seen only in the morning from the beginning of January until the beginning of May. On the 1st of February, it will rise at 5h. 8', a. m., in a direction nearly south-east, and will come to the meridian at 9h. 8', a. m., at an altitude of  $15^{\circ} 35'$ ; on the 1st of March, it rises at twenty-eight minutes past three in the morning; on the 1st of April, at thirty-one minutes past one; and on the 1st of May, at thirty-two minutes past eleven in the evening. From January until May the planet will be seen chiefly in a south-easterly direction in the morning, at a small elevation above the horizon. From July until October it will be seen in the evening, chiefly in a southerly and south-by-west direction. It is in opposition to the sun on the 21st of June, when it rises about eight in the evening, and passes the meridian about midnight. It will be in conjunction with the sun on the 27th of December. Its right ascension on the 1st of January is 17h. 43', and its south declination,  $22^{\circ} 21'$ . On the 31st of December, its right ascension is 18h. 26', and south declination,  $22^{\circ} 40'$ . On account of its great southern declination and its vicinity to the sun, it will not be much noticed during the latter part of October and the months of November and December.

During this year the ring of Saturn will be in a very favorable position for telescopic observation, the elliptical figure of the ring appearing nearly at its utmost width, so that it will appear very nearly to encompass the planet. The best periods for telescopic observations in the evening will be from the month of May, until the end of September.

VOL. II.—29

#### VII. URANUS.

Uranus will be in opposition to the sun on the 15th of September, at 10h. 17', a. m., when it will pass the meridian about midnight, at an altitude of  $34^{\circ} 15'$ . Right ascension at this period, 23h.  $33\frac{1}{2}'$ ; south declination,  $3^{\circ} 45'$ . It is in conjunction with Venus on the 25th of January, at twenty-five minutes past one in the morning, and is distant from Venus only four minutes of a degree. It is in conjunction with Vesta on the 9th of April, at nine in the evening, being  $3^{\circ} 54'$  to the north of Vesta. On the 1st of September, it passes the meridian at fifty-one minutes past twelve, midnight; on the 1st of October, at forty-nine minutes past ten in the evening; on the 1st of November, at forty-three minutes past eight; on the 1st of December, at forty-four minutes past six; and on the 1st of January, 1842, at forty-four minutes past four in the afternoon. The most eligible periods for detecting this planet by means of the telescope are the months of August, September, October, and November.

N. B. The preceding descriptions of planetary phenomena are chiefly intended to inform common observers as to the seasons of the year when the different planets may be seen, and the quarters of the heavens to which they are to direct their attention in order to distinguish them. It may be proper to observe, that the planets in general cannot be distinguished by the naked eye for about a month before and after their conjunctions with the sun, except Venus, which may frequently be seen within a week before and after its inferior conjunction; but this planet will sometimes be invisible to the naked eye for a month or two before and after its superior conjunction with the sun.

For a particular description of the motions, distances, magnitudes, and other phenomena in relation to the primary planets and their satellites, the reader is respectfully referred to the volume entitled "CELESTIAL SCENERY; or the Wonders of the Planetary System Displayed;" where all the most interesting facts connected with the solar system, and the scenery it displays, are particularly detailed.

### ECLIPSES AND OCCULTATIONS.

#### ECLIPSES IN 1840.

There will be four eclipses this year, two of the sun and two of the moon; but none of them will be visible within the limits of the British isles, nor in the United States of America, except a partial eclipse of the moon, August 13th, at 7h. 23', a. m., Greenwich time. This eclipse will be visible at Philadelphia, New York, Boston, and most parts of North America, but not in Britain. On March 4th, there will be an annular eclipse of the sun, the middle of which will happen at 7h. 23', a. m.; and on August 27th there will be a total eclipse of the sun; middle of the eclipse about 7h., a. m. These two interesting eclipses will be visible chiefly in the eastern parts of the globe, in the eastern parts of Africa, the East Indies, the Indian Ocean, Australia, &c. At the Cape of Good Hope, there will be a partial eclipse of the sun on August 27th; but both eclipses will be invisible both in Britain and America.

#### ECLIPSES IN 1841.

This year there will be six eclipses, four of the sun and two of the moon, at the following times:

Of the *sun*, January 22d, at 5h. 23', a partial eclipse, visible only in a small portion of the southern ocean; of the *moon*, February 6th, at 2h. 6', A. M., visible in Great Britain; of the *sun*, a partial eclipse, February 21st, at 11h. 4', A. M., visible chiefly in the North Atlantic Ocean, Iceland, and East Greenland; of the *sun*, a partial eclipse, July 18, at 2h. 24', P. M., visible in Baffin's Bay, Iceland, Norway, Sweden, Russia in Europe, Prussia, Germany, Scotland, &c., but invisible at Greenwich; of the *moon*, a total eclipse, August 2d, at 10h. 1', A. M.; of the *sun*, a partial eclipse, August 16th, at 9h. 19', P. M., visible chiefly in the South Pacific Ocean. The times here specified denote the *middle* of the eclipse.

All the above eclipses are invisible at Greenwich, and in most parts of Britain, except the total eclipse of the moon on February 5th and 6th, of

which the following is a more particular detail in mean time at Greenwich:

	h. m.	
First contact with penumbra of the earth's shadow, Feb. 5.....	11 24	P. M.
First contact with dark shadow, Feb. 6.....	0 20	A. M.
First total immersion in dark shadow, Feb. 6.....	1 17	A. M.
Middle of the eclipse, Feb. 6.....	2 6½	A. M.
Last total immersion in dark shadow, Feb. 6.....	2 55½	A. M.
Last contact with dark shadow, Feb. 6.....	3 52½	A. M.
Last contact with penumbra, Feb. 6, 4 49		A. M.
Digits eclipsed,	20½	

A large *solar* eclipse will be visible on July 8,

#### PLATE IV.

#### THE SOUTH CIRCUMPOLAR STARS.

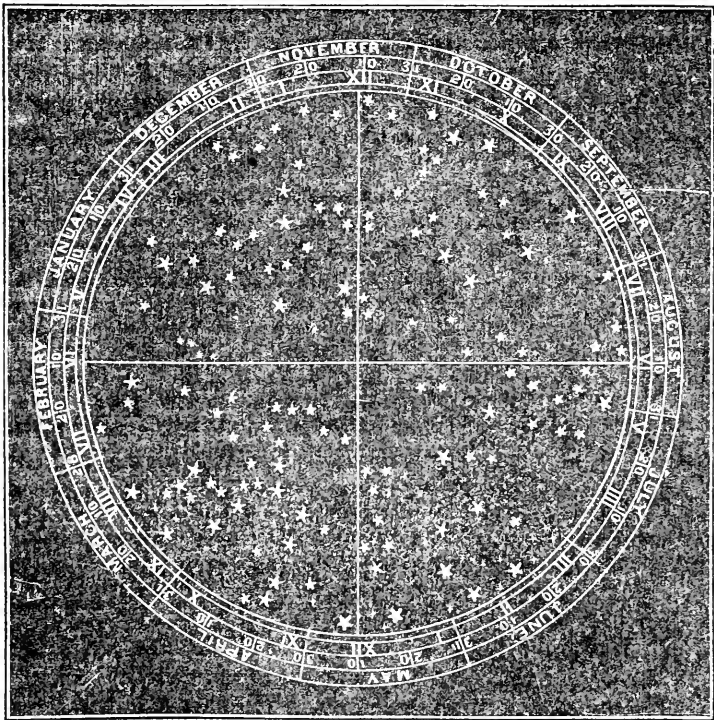

1842; and no eclipse of the sun will be visible in Britain until that time. That eclipse will be *total* in the southern parts of France, and large even in and near London. At Greenwich, it will begin at 4h. 52½', A. M., and end at 6h. 43'. Digits eclipsed 9° 42½'. Of course this eclipse will not be visible in the United States, nor throughout any part of America, as the sun will not at that time be risen to those places.

#### OCCULTATIONS OF VENUS BY THE MOON IN 1841.

On the 26th of March, 1841, the planet Venus will suffer an occultation by the moon. It will begin to be immersed behind the moon at forty minutes past two o'clock in the afternoon, of Greenwich mean time, and will emerge from be-

hind the opposite limb of the moon at twenty-three minutes past 3, P. M. Another occultation of Venus will happen on the 12th of September, 1841; immersion, thirty minutes past six in the morning; emersion, forty-two minutes past 7, A. M. In the occultation of March 26, Venus will be nearly in the form of a half moon, and the moon in the form of a crescent. Venus will be immersed at the dark (or eastern) limb of the moon, and will emerge from the enlightened crescent. They will be then nearly on the meridian, at an altitude of about 60°, and nearly three hours of right ascension east of the sun. A short time after sunset, Venus will be seen a little west from the lunar crescent, but very near it, shining with considerable splendor. Although this occultation will happen while the sun is above the horizon, yet

both the moon and Venus will be easily perceived with a common telescope of very moderate magnifying power. In the occultation which takes place on the morning of September 12, Venus will, as in the former case, be nearly in the shape of a half moon, and the moon a slender crescent, being only  $2\frac{1}{2}$  days from the period of conjunction or new moon. In this case Venus will be immersed at the enlightened limb of the moon, and emerge from the dark limb. Both bodies will be then in an easterly or north-easterly direction, and the immersion will take place a little after sunrise; about half an hour before which, Venus will be seen a very little to the east of the moon.

#### EXPLANATIONS OF SOME OF THE ENGRAVINGS OF THE STARS.

PLATES I and II, which represent portions of the heavens as seen about the middle of January and the 1st of September, have been explained pp.

13-16; and PLATE III, which represents the north circumpolar stars has been explained pp. 16-19.

PLATE IV represents some of the larger stars and principal constellations around the *South Pole*, to the distance of  $45^\circ$  from that pole. It also shows a portion of the Milky Way which traverses that region of the heavens, and which is said to appear there with peculiar brilliancy. One of the principal constellations which is frequently noticed, and which appears peculiarly striking to sea-faring people and others, is called *Cruz*, or the *Cross*, from the resemblance it bears to that figure. It consists of five stars, one of the first magnitude, two of the second, one of the third, and one of the fourth magnitude. Four of these are in the position of the cross; the northernmost and southernmost of which are always in a line with the south pole, and therefore serve for a direction in south latitude to discover that pole, as the Two Pointers in the Great Bear serve to direct the eye to the *North Polar*-star. There is no large or prominent star at or near the *South Pole*. This con-

Fig. 85.

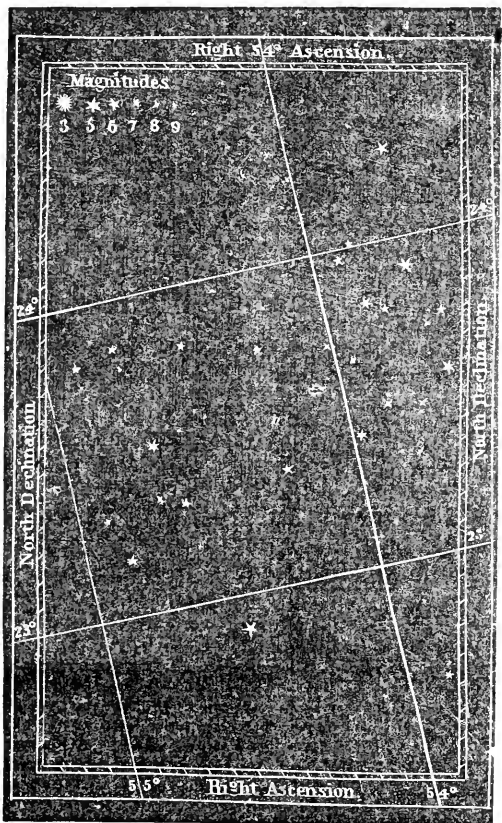

stellation is represented near the line, or meridian, which points at XII, opposite to the month of *May*. All its stars, except the lowermost, appear within the limits of the Milky Way. The stars immediately below the Cross belong to the *Centaur*; those on the left, opposite *April*, belong to *Robur Carolæ*, or King Charles's Oak, which contains a star of the first magnitude. Farther to the left, opposite *March*, is *Argo Navis* or the *Ship*.

Still farther to the left, opposite *February*, is *Pisces Volans*, the Flying Fish, which contains a star of the first magnitude, named *Canopus*. This star is marked near the left side of the map, opposite the middle of February. To the *right* from the Cross are the two fore legs of the *Centaur*, distinguished by two stars of the first magnitude, named *Agena* and *Bangula*, Agena being the one next to the Cross. They are in the Milky Way,

and appear opposite the month of *June*. Next to the Cross and the Centaur, on the right, are *Circinus*, or the Compasses; the Southern *Triangle*, which contains three stars of the second magnitude in the form of a triangle; and *Ara*, or the Altar, which lies adjacent to the right-hand side of the map, opposite the space between *July* and *August*.

Directing our attention to the upper part of the map, on the left, there is the constellation *Equuleus Pictoria*, or the Painter's Easel, which consists of a number of small stars. Next to this, and a little above it, is *Dorado*, or the Sword-Fish, which contains two or three stars of the second and third magnitudes. To the right of *Dorado* is *Hydrus*, or the Water Snake; above which is *Achernar*, a star of the first magnitude in *Eridanus*, which appears opposite the 1st of *December*. Next to *Achernar* on the right is *Toucana*, or the Amer-

ican Goose; above which, opposite *November*, is the *Phoenix*; to the right of which is the *Crane*, which contains two stars of the second magnitude; below which is *Pavo*, or the Peacock, which contains several stars of the second and third magnitudes; below *Pavo*, opposite to *August*, is *Telescopium*, or the Telescope, which contains no remarkable stars. Within eleven degrees of the South Pole, represented by the central point of the map, are two of those whitish or nebulous spaces called the *Magellanic Clouds*, which are found by the telescope to consist of small stars and nebulous appearances. The other *Magellanic cloud*, which is the largest, is at a considerable distance from the South Pole. In specifying the names of some of the above-stated constellations, the *incongruity* of the animals and figures by which these groups of stars are represented will at once be apparent to the reader.

Fig. 86.

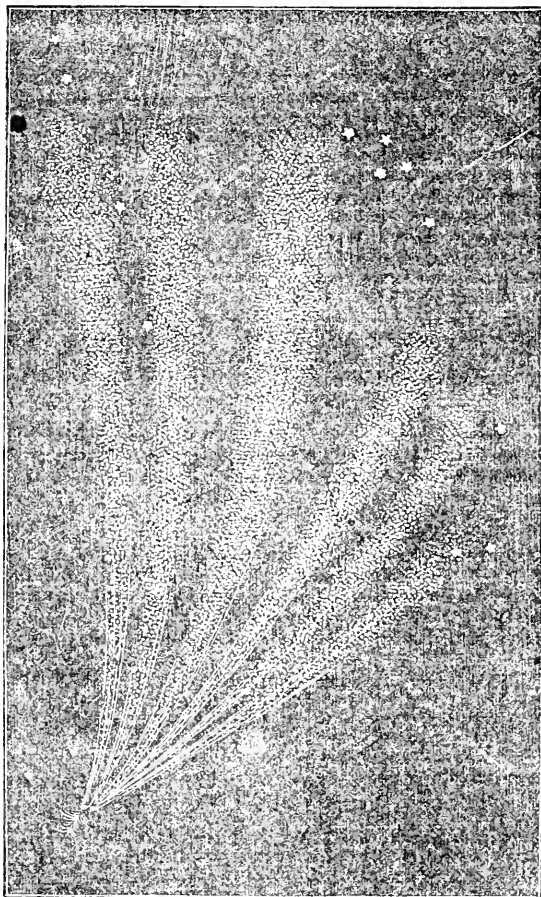

PLATE V. contains a condensed representation of some of the principal constellations in the northern and southern hemispheres on *Mercator's Projection*, chiefly for the purpose of exhibiting the course of the MILKY WAY, and the relative positions of the constellations. Some of the larger stars may be here traced as  $\alpha$  Lyræ, Capella, &c., but they are more easily distinguished in the other maps. (See the description given of the Milky Way p. 57.)

Fig. 80 (p. 124) represents the comet of 1661, as seen by Hevelius; the atmosphere, or nebulosity, surrounding the nucleus, when viewed at different times, varied in its extent, as likewise the tail in its length and breadth.

Fig. 81 (p. 124) represents a class of comets which have their tails somewhat bent, which some suppose to be owing to the resistance of the ethereal fluid through which they move.

Fig. 85 represents a telescopic view of the *Plei-*

*des*, a group of stars in the constellation Taurus. About forty stars are here represented, but with powerful telescopes many more may be discovered. *Rheita* affirms that he counted 200 stars within this cluster, and yet telescopes, at the period when he lived, had not arrived at the point of perfection they have now attained. The principal star in the Pleiades is *Alcione*, of the third magnitude, which is here represented near the center of the cluster. The names of the others visible to the naked eye are *Merope*, *Maia*, *Electra*, *Tayeta*, *Sterope*, and *Celine*. *Merope* is the one which some suppose to have been lost. In fabulous history, these stars were the seven daughters of *Atlas* and the nymph *Pleione*, who were turned into stars with their sisters the *Hyades*, on account of their mutual affection and amiable virtues.

The other five stars, beside *Alcione*, are of the fifth magnitude, as represented in the plate; and the rest are telescopic stars of the sixth, seventh, eighth, and ninth magnitudes. The lines from

right to left are portions of circles of declination which run parallel with the equinoctial, as the parallels of latitude on the terrestrial globe do with respect to the equator; and on these the *declination*, or distance of the body from the equinoctial, is marked. The other lines, from top to bottom, are portions of circles of right ascension corresponding with meridians on the terrestrial globe. On these are marked the right ascensions of the heavenly bodies or their distance, reckoned on the equinoctial from the first point of Aries. One of these lines, at the top and bottom, is marked  $54^{\circ}$ , showing that the stars in that line are  $54^{\circ}$  east from the first point of Aries; and the number 23, marked at the right and left hand sides, shows that the star or stars in that line are  $23^{\circ}$  north of the equinoctial.

Fig. 86 represents the tail of the splendid comet of 1744, which was divided into six branches, as described p. 127. See also the description given of this comet, pp. 122, 123.





THE  
PRACTICAL ASTRONOMER,

COMPRISING

ILLUSTRATIONS OF LIGHT AND COLORS—PRACTICAL DESCRIPTIONS OF ALL  
KINDS OF TELESCOPES—THE USE OF THE EQUATORIAL-TRANSIT—  
CIRCULAR, AND OTHER ASTRONOMICAL OBSERVATIONS;

A PARTICULAR ACCOUNT OF THE

EARL OF ROSSE'S LARGE TELESCOPES;

AND OTHER TOPICS CONNECTED WITH ASTRONOMY.



## P R E F A C E .

---

THE following work was announced several years ago in the preface to the volume on "The Sidereal Heavens," since which time numerous inquiries have been made after it by correspondents in England, the West Indies, and America. It was nearly ready for publication three years ago, but circumstances over which the author had no control prevented its appearance at that period. This delay, however, has enabled him to introduce descriptions of certain instruments and inventions which were partly unknown at the time to which he refers.

The term "Practical Astronomer" has been fixed upon as the shortest that could be selected, although the volume does not comprise a variety of topics and discussions generally comprehended in this department of astronomy. The work is intended for the information of general readers, especially for those who have acquired a relish for astronomical pursuits, and who wish to become acquainted with the instruments by which celestial observations are made, and to apply their mechanical skill to the construction of some of those which they may wish to possess. With this view, the author has entered into a variety of minute details, in reference to the construction and practical application of all kinds of telescopes, &c., which are not to be found in general treatises on Optics and Astronomy.

As *Light* is the foundation of astronomical science, and of all the instruments used for celestial observation, a brief description is given of the general properties of light—of the laws by which it is refracted and reflected when passing through different mediums, and of the effects it produces in the system of nature—in order to prepare the way for a clear understanding of the principles on which optical instruments are constructed, and the effects they produce.

As this, as well as every other physical subject, forms a part of the arrangements of the Creator throughout the material system, the author has occasionally taken an opportunity of directing the attention of the reader to the Wisdom and Beneficence of the Great First Cause, and of introducing those moral reflections which naturally flow from the subject.

The present is the ninth volume which the author has presented to the public, and he indulges the hope that it will meet with the same favorable reception which his former publications have uniformly experienced. It was originally intended to conclude the volume with a few remarks on the *utility* of astronomical studies, and their *moral* and *religious* tendency, but this has been prevented, for the present, in consequence of the work having swelled to a greater size than was anticipated. Should he again appear before the public as an author, the subject of discussion and illustration will have a more direct bearing than the present on the *great objects* of religion and a future world.

BROUGHTY FERRY, NEAR DUNDEE.



# CONTENTS.

## PART I.

ON LIGHT.

### INTRODUCTION.

	PAGE.
Necessity of light to the knowledge and happiness of all Sentient Beings. Its beautiful and enlivening effects. An emblem of the Deity. Provision made for its universal diffusion . . .	11

### CHAPTER I.

GENERAL PROPERTIES OF LIGHT.

Interesting nature of this study. Different Hypotheses which have been formed respecting the nature of light. It radiates in straight lines—moves with amazing velocity—flows in all directions from luminous bodies. Duration of its impressions on the eye. Supposed to have a certain degree of force or momentum. Experiments in relation to this point. Its intensity diminished in proportion to the square of the distance. Its reflection from opaque bodies renders objects visible. Intensity of reflected light. Subject to the law of attraction. Forms a constituent part of certain bodies. <i>Solar Phosphori</i> , and the phenomena they exhibit. Produces certain effects on plants and flowers, exemplified in a variety of instances Supposed to have an influence on the <i>propagation of sound</i> .....	13
Reflections on the nature of light, and the multifarious effects it produces throughout the universe. A representation of the Divinity. Wisdom and goodness of God displayed in its formation .....	19

### CHAPTER II.

ON THE REFRACTION OF LIGHT.

Nature of refraction—illustrated by experiments. Angle of refraction. Familiar experiments illustrative of refraction. Refraction explains the causes of many curious and interesting phenomena. Its effect on the heavenly bodies—on the twilight. Illustrated by figures.....	21
---	----

EXTRAORDINARY CASES OF REFRACTION IN RELATION TO TERRESTRIAL OBJECTS.

Extraordinary appearance of the Coast of France from Hastings. Appearance of a ship seen by Captain Colby, beyond the Coast of Caithness. Scoresby's view of his father's ship when beyond the horizon. Phenomenon near the Himalaya Mountains. Bell Rock Light-House. Summary statement of the diversified effects of refraction. Reflections on the beneficent and diversified effects produced by the law of refraction. It increases the length of the day, particularly in the Polar regions—is the cause of that splendor which appears in the objects around us. Quantity of refraction in respect to terrestrial objects, and its utility. Its effects may be more diversified in other worlds.....	24
---	----

### CHAPTER III.

ON THE REFRACTION OF LIGHT THROUGH SPHERICAL TRANSPARENT SUBSTANCES, OR LENSES.

Refraction the foundation of optical instruments. Various forms of lenses. <i>Parallel, converging, and diverging</i> rays—illustrated by diagrams. <i>Concave</i> lenses—their effects, and how to find their focal distances. Images formed by convex lenses—illustrated by experiments. Principles in relation to images formed by lenses. Their magnifying powers, &c.....	26
--	----

REFLECTIONS DEDUCED FROM THE PRECEDING SUBJECT.

Property of the rays of light in forming *images* of objects. Wonderful results and discoveries which have flowed from this property in relation to our knowledge of the scenery of the heavens and the minute parts of nature, and of our views of the attributes of Deity..... 29

CHAPTER IV.

ON THE REFLECTION OF LIGHT.

Nature of reflection. Plane, convex, and concave speculums. Angle of reflection. Reflection of objects from plane mirrors, illustrated by figures. *Reflection by convex and concave mirrors.* Properties of *convex* mirrors, and the purposes to which they are applied. Properties of concave speculums, and their utility. Of the *images* formed by concave speculums—illustrated by a variety of figures and experiments—their power of magnifying and burning. Amusing deceptions produced by. Resemblance between the properties of convex lenses and concave mirrors. Quantity of light reflected by polished surfaces..... 31

UNCOMMON APPEARANCES OF NATURE PRODUCED BY THE COMBINED INFLUENCE OF REFLECTION AND REFRACTION.

*Fata Morgana.* The Mirage. Inverted images of ships seen in the horizon. Appearance of Dover Castle at Ramsgate. Specter of the Brocken. Scenes in the Highlands of Scotland. Large cross seen at Migne in France. Dr. Wollaston's illustrations of such phenomena. Utility of science in dissipating superstitious fears..... 37

REMARKS AND REFLECTIONS IN REFERENCE TO THE PHENOMENA DESCRIBED ABOVE.

Light, the beauty of the universe, and a symbol of the divinity. In other worlds it may produce an infinite variety of sublime Scenery..... 40

CHAPTER V.

SECTION I.

ON THE COLORS OF LIGHT.

Colors, the beauty of nature. Opinions which were formerly entertained respecting their cause. Sir I. Newton's experiments with the prism. Colors and phenomena produced by the prism. Imperfection of optic lenses. Various illustrations. Differently colored rays have not the same illuminating power. Heating and chemical properties of some of the rays of the solar spectrum. Property of communicating the magnetic power. Fraunhofer, and his discoveries in reference to the spectrum. Experiments on white and colored light..... 41

SECTION II.

ON THE COLORS OF NATURAL OBJECTS.

Colors not in the objects themselves, but in the light which falls upon them. Illustrations of this position. Atmosphere the source of a variety of colors. Various natural phenomena, in relation to color, explained..... 44

SECTION III.

PHENOMENA OF THE RAINBOW.

Rainbow described Experiments to illustrate its cause. Descriptions of its various phenomena, and optical explanations of their causes. Rainbows exhibiting *complete circles.* Their appearance in different countries. Summary view of the principal facts respecting the rainbow. *Lunar* rainbows. Scriptural allusions to the rainbow. Whether there was any rainbow before the Deluge. .... 46

SECTION IV.

REFLECTIONS ON THE BEAUTY AND UTILITY OF COLORS.

Beauty and variety derived from colors in the scenery of nature. Colors produced by the atmosphere in different countries. What would be the aspect of nature, in heaven and on earth, were there only one color. How it would affect the common intercourse and employments of society. Wisdom and beneficence of the Creator displayed in the diversity of colors. Throughout all the systems of the universe a diversity of colors prevails. This subject has a tendency to inspire us with gratitude..... 49

## PART II.

## ON TELESCOPES.

## CHAPTER I.

## HISTORY OF THE INVENTION OF TELESCOPES.

The telescope a noble instrument. Effects it produces. Whether known to the ancients. Friar Bacon's ideas respecting telescopes. First constructed in Holland. The invention claimed by different persons. Galileo's account of the construction of his telescope. Discoveries which he made with this instrument. How his discoveries were received by the learned. Specimens of learned nonsense brought forward by pretended philosophers. Supposed length of Galileo's telescope. Various claimants to the invention of this instrument..... 52

## CHAPTER II.

## ON THE CAMERA OBSCURA.

Appearance of objects in a camera obscura. The dark chamber. This instrument serves to explain the nature of a refracting telescope. Particulars to be attended to in exhibiting objects with the camera. It illustrates the nature of vision. Revolving camera obscura. *Portable camera*..... 56

## THE DAGUERRETYPE.

An important discovery for fixing the images produced by the camera. Description of the Daguerreotype process—preparation of the plate, fixing the impression, &c. Preparation of photogenic paper. Beneficial effects which this art may produce. Representations of objects in the heavens, &c..... 59

## CHAPTER III.

## ON THE OPTICAL ANGLE, AND THE APPARENT MAGNITUDE OF OBJECTS.

Various illustrations of the apparent magnitude of objects. Fallacies in relation to apparent magnitudes. Apparent magnitudes in the heavens. Difference between *absolute* and apparent magnitudes..... 61

## CHAPTER IV.

## ON THE DIFFERENT KINDS OF REFRACTING TELESCOPES

## SECTION I.

## THE GALILEAN TELESCOPE.

Construction and peculiar properties of this instrument..... 63

## SECTION II.

## THE COMMON ASTRONOMICAL REFRACTING TELESCOPE.

Description of its nature and construction. How its magnifying power is determined. Table of the linear aperture, magnifying powers, &c., of astronomical telescopes from 1 to 120 feet in length. Summary view of the properties of this telescope..... 64

## SECTION III.

## THE AERIAL TELESCOPE.

This telescope is used without a tube. Description of the apparatus connected with it, illustrated with figures. Huygen's, Hartsocker's, and Cassini's large telescopes..... 66

## SECTION IV.

## THE COMMON REFRACTING TELESCOPE FOR TERRESTRIAL OBJECTS.

Arrangement of its lenses. Magnifying power. Manner in which the rays of light are refracted through the telescope now described..... 67

## SECTION V

## TELESCOPE FORMED BY A SINGLE LENS.

Various experiments in relation to this point. Experiments with a lens 26-feet focal distance, and 11½ inches diameter.....	68
---	----

## SECTION VI.

## THE ACHROMATIC TELESCOPE.

Imperfections of common refracting telescopes. Dollond's discovery. Newton's error. Explanation of the principle of achromatic telescopes. Combination of lenses. Difficulties in the construction of such instruments. Difficulty in procuring large discs of flint glass. Guinaud's experiments.....	68
--	----

## NOTICES OF SOME LARGE ACHROMATIC TELESCOPES ON THE CONTINENT, AND IN GREAT BRITAIN.

The Dorpat telescope—Sir J. South's telescope—Captain Smyth's—Rev. Dr. Pearson's—Mr. Lawson's—Mr. Cooper's—Mr. Bridges', &c. Achromatics in Cambridge and Paris Observatories.....	72
--	----

## ACHROMATIC TELESCOPES OF A MODERATE SIZE, WITH THEIR PRICES, AS SOLD BY LONDON OPTICIANS.

The 2½-feet achromatic—the 3½-feet. The powers applied to it, and the views it gives of the heavenly bodies. The 5-feet achromatic. <i>Stands</i> for telescopes, illustrated by engravings...	73
--	----

## PROPORTIONS OF CURVATURE OF THE LENSES WHICH FORM AN ACHROMATIC OBJECT-GLASS.

Various tables and explanations.....	76
--------------------------------------	----

## ACHROMATIC TELESCOPES COMPOSED OF FLUID LENSES.

Blair's fluid telescope, with an account of its performance. Barlow's large refracting telescope, with a fluid concave lens—its construction, and the effect it produces on double stars, &c. Rodger's achromatic telescope on a new plan. Wilson's telescope, &c.....	77
--	----

## CHAPTER V.

## ON REFLECTING TELESCOPES.

## SECTION I.

## HISTORY OF THE INVENTION, AND A GENERAL DESCRIPTION OF THE CONSTRUCTION OF THESE INSTRUMENTS.

Gregory's reflector—Newtonian reflector—Cassegrainian reflector. Magnifying powers of reflectors. Short's reflectors—their powers and prices. <i>General remarks on Gregorian reflectors</i> . Apertures and magnifying powers of Newtonian telescopes. <i>Prices</i> of reflecting telescopes.....	81
---	----

## SECTION II.

## THE HERSCHELIAN TELESCOPE.

Description of Sir W. Herschel's 40-feet telescope, with its machinery, apparatus, and the discoveries made by it. Sir J. Herschel's 20-feet reflector.....	86
---	----

## SECTION III.

Ramage's large reflecting telescope.....	88
--	----

## SECTION IV.

## THE AERIAL REFLECTOR—CONSTRUCTED BY THE AUTHOR.

Construction of this telescope, and the manner of using it—illustrated by figures—its proprieties and advantages. Tube not necessary in reflecting telescopes. How a large reflector may be constructed without a tube. How the form of a telescope may be used for viewing perspectives.	88
---	----

## SECTION V.

## EARL OF ROSSE'S REFLECTING TELESCOPES.

His mode of forming a large speculum, &c.—see also Appendix.....	92
--	----



SECTION VI.

REFLECTING TELESCOPES WITH GLASS SPECULA.

Various experiments on this subject, with their results..... 93

SECTION VII.

A REFLECTING TELESCOPE WITH A SINGLE MIRROR AND NO EYEPIECE.

Experiments illustrative of this construction. .... 93

ON THE EYEPIECES OF TELESCOPES. ASTRONOMICAL EYEPIECES.

Huygenian eyepieces—Ramsden's eyepiece. Aberration of lenses. Celestial eyepieces without variable powers. *Diagonal* eyepieces. Various forms of them described. Various aspects in which objects may be viewed by them. .... 95

SECTION VIII.

TERRESTRIAL EYEPIECES.

Eyepieces with four lenses. Proportions of the focal lengths of these lenses. Dimensions and powers of several eyepieces stated..... 98

DESCRIPTION OF AN EYEPIECE, ETC., OF AN OLD DUTCH ACHROMATIC TELESCOPE.

This telescope supposed to have been *invented* in Holland before Dollond's discovery was known. Peculiarity of its eyepiece..... 99

SECTION IX.

Description of the Pancratic Eyetube..... 100

CHAPTER VI.

MISCELLANEOUS REMARKS IN RELATION TO TELESCOPES.

I. Adjustments requisite to be attended to in the use of telescopes. II. State of the atmosphere most proper for observing terrestrial and celestial objects. Average number of hours in the year fit for celestial observations. III. On the magnifying powers requisite for observing (the phenomena of the different planets—comets—double stars, &c)—illustrated at large from pp. 103-107. IV. Mode of exhibiting the solar spots. Eyepieces best adapted for this purpose. How they may be exhibited to a large company. Mode in which their dimensions may be determined. V. On the *space-penetrating* power of telescopes. Herschel's observations on space-penetrating powers. Comparison of Achromatic and Gregorian reflectors. VI. On choosing telescopes, and ascertaining their properties—various modes of ascertaining the goodness of telescopes—general remarks and cautions on this point. A circumstance which requires to be attended to in using achromatics. VII. On the mode of determining the magnifying power of telescopes. Various experiments in relation to this point. VIII. On cleaning the lenses of telescopes..... 101

ON MEGALASCOPES, OR TELESCOPES FOR VIEWING VERY NEAR OBJECTS.

Mode of adapting a telescope for this purpose. Objects to which they may be applied..... 112

REFLECTIONS ON LIGHT AND VISION, AND ON THE NATURE AND UTILITY OF TELESCOPES.

Wonderful and mysterious nature of light. The organ of vision, and its expansive range. Wonderful nature of the telescope, and the objects it has disclosed to view. No boundaries should be set to the discoveries of Science and the improvement of art. The telescope is a machine which virtually transports us to the distant regions of space. It enlarges our views of the sublime scenes of creation. It has tended to amplify our conceptions of the empire and the attributes of the Deity. Various uses of this instrument in relation to science and common life..... 113

CHAPTER VII.

ON THE METHOD OF GRINDING AND POLISHING OPTICAL LENSES AND SPECULA.

I. Directions for grinding lenses for eyeglasses, microscopes, &c. II. Method of casting and grinding the specula of reflecting telescopes. Compositions for speculum metal. To try the figure of the metal. To adjust the eyehole of Gregorian reflectors—to center the specula—to center lenses..... 119

## PART III.

## ON VARIOUS ASTRONOMICAL INSTRUMENTS.

## CHAPTER I.

## ON MICROMETERS.

Various descriptions of micrometers. *Cavallo's* micrometer described. To ascertain the value of its divisions. Practical uses of this micrometer. Problems which may be solved by it. Tables for facilitating its use..... 129

## CHAPTER II.

## ON THE EQUATORIAL TELESCOPE, OR PORTABLE OBSERVATORY.

History of Equatorials. Description of one of the simplest construction of these instruments. To adjust the equatorial for observation—to adjust the line of sight. Description of the *Nonius*. To find the meridian line by one observation. Manner of observing stars and planets in the day-time..... 124

OBSERVATIONS, BY THE AUTHOR, ON THE FIXED STARS AND PLANETS, MADE IN THE DAY-TIME, BY THE EQUATORIAL.

Object of these observations. Stars of the first and second magnitudes. General deductions from these observations..... 127

## OBSERVATIONS ON THE PLANETS IN THE DAY-TIME.

Series of observations on *Venus*, when near the sun—seen at the time of her superior conjunction in 1843. Conclusions deduced from these observations. Phenomena observed during these observations. Remarkable phenomena during an eclipse of the sun..... 128

## OBSERVATIONS ON JUPITER AND OTHER PLANETS.

General conclusions, &c..... 131  
 Utility of celestial day observations..... 132  
 On the astronomical quadrant..... 134  
 The astronomical circle..... 135  
 The transit instrument..... 136

## CHAPTER III.

## ON OBSERVATORIES.

Leading features of a spot adapted for celestial observations. Public and private Observatories. Greenwich Observatory. Instruments with which an Observatory should be furnished. The author's private Observatory. Revolving domes for Observatories. Cautions to be attended to in celestial observations..... 138

## CHAPTER IV.

## ON ORRERIES OR PLANETARIUMS.

History of such machines. Sphere of Archimedes and Ptolemy. Dr. Long's *Uranium*. Wheel-work of the common planetarium. Figure representing this machine. Problems which may be performed by it..... 140

## DR. HENDERSON'S PLANETARIUM.

Section of its wheel-work. Number of teeth in the wheels and pinions which move the different planets. Extreme accuracy of these movements..... 143

ON THE VARIOUS OPINIONS WHICH WERE ORIGINALLY FORMED OF SATURN'S RING, ILLUSTRATED WITH THIRTEEN VIEWS.

When and by whom its true figure was discovered..... 146

## ON THE SUPPOSED DIVISION OF THE EXTERIOR RING OF SATURN.

Kater's, Short's, Quetelet's, and Decuppi's observations..... 147

## APPENDIX.

## I. DESCRIPTION OF THE EARL OF ROSSE'S LARGEST TELESCOPE.

Composition of the speculum, and the process of casting it. Mode of grinding and polishing it. Manner in which it is filled up. Expenses incurred in its construction. Results of observations which have been made with it. Two views representing this instrument and the buildings connected with it. Sir J. South's remarks and anticipations..... 148

II. HINTS TO AMATEURS IN ASTRONOMY RESPECTING THE CONSTRUCTION OF TELESCOPES. .... 152

# THE PRACTICAL ASTRONOMER.

## PART I. ON LIGHT.

### INTRODUCTION.

LIGHT is that invisible ethereal matter which renders objects perceptible by the visual organs. It appears to be distributed throughout the immensity of the universe, and is essentially requisite to the enjoyment of every rank of preceptive existence. It is by the agency of this mysterious substance that we become acquainted with the beauties and sublimities of the universe, and the wonderful operations of the Almighty Creator. Without its universal influence, an impenetrable veil would be thrown over the distant scenes of creation; the sun, the moon, the planets, and the starry orbs would be shrouded in the deepest darkness, and the variegated surface of the globe on which we dwell would be almost unnoticed and unknown. Creation would disappear, a mysterious gloom would surround the mind of every intelligence, all around would appear a dismal waste and an undistinguished chaos. To whatever quarter we might turn, no form nor comeliness would be seen, and scarcely a trace of the perfections and agency of an All-wise and Almighty Being could be perceived throughout the universal gloom. In short, without the influence of light, no world could be inhabited, no animated being could subsist in the manner it now does, no knowledge could be acquired of the works of God, and happiness, even in the lowest degree, could scarcely be enjoyed by any organized intelligence.

We have never yet known what it is to live in a world deprived of this delightful visitant; for in the darkest night we enjoy a share of its beneficial agency, and even in the deepest dungeon its influence is not altogether unfeelt.\* The blind, indeed, do not directly enjoy the advantages of light, but its influence is reflected upon them, and their knowledge is promoted through the medium of

those who enjoy the use of their visual organs. Were all the inhabitants of the world deprived of their eyesight, neither knowledge nor happiness, such as we now possess, could possibly be enjoyed.

There is nothing which so strikingly displays the beneficial and enlivening effects of light as the dawn of a mild morning after a night of darkness and tempest. All appears gloom and desolation in our terrestrial abode until a faint light begins to whiten the eastern horizon. Every succeeding moment brings along with it something new and enlivening. The crescent of light toward the east now expands its dimensions, and rises upward toward the cope of heaven; and objects, which a little before were immersed in the deepest gloom, begin to be clearly distinguished. At length the sun arises, and all nature is animated by his appearance; the magnificent scene of creation, which a little before was involved in obscurity, opens gradually to view, and every object around excites sentiments of wonder, delight, and adoration. The radiance which emanates from this luminary displays before us a world strewed with blessings, and embellished with the most beautiful attire. It unveils the lofty mountains and the forests with which they are crowned; the fruitful fields, with the crops that cover them; the meadows, with the rivers which water and refresh them; the plains, adorned with verdure; the placid lake, and the expansive ocean. It removes the curtain of darkness from the abodes of men, and shows us the cities, towns, and villages, the lofty domes, the glittering spires, and the palaces and temples with which the landscape is adorned. The flowers expand their buds and put forth their colors, the birds awake to melody, man goes forth to his labor, the sounds of human voices are heard, and all appears life and activity, as if a new world had emerged from the darkness of chaos.

The whole of this splendid scene, which light produces, may be considered as a new creation, no less grand and beneficent than the first creation, when the command was issued, "Let there be light, and light was." The aurora and the rising sun cause the earth, and all the objects which adorn its surface, to arise out of that pro-

\* Those unfortunate individuals who have been confined in the darkest dungeons have declared, that though, on their first entrance, no object could be perceived, perhaps for a day or two, yet, in the course of time, as the pupils of their eyes expanded, they could readily perceive mice, rats, and other animals that infested their cells, and likewise the walls of their apartments; which shows that, even in such situations, light is present, and produces a certain degree of influence.

found darkness and apparent desolation which deprived us of the view of them as if they had been no more. It may be affirmed, in full accordance with truth, that the efflux of light in the dawn of the morning, after a dark and cloudy night, is even more magnificent and exhilarating than at the first moment of its creation. At that moment there were no spectators on earth to admire its glorious effects; and no objects, such as we now behold, to be embellished with its radiance. The earth was a shapeless chaos, where no beauty or order could be perceived; the mountains had not reared their heads; the seas were not collected into their channels; no rivers rolled through the valleys; no verdure adorned the plains; the atmosphere was not raised on high to reflect the radiance, and no animated beings existed to diversify and enliven the scene. But now, when the dawning of the morning scatters the darkness of the night, it opens to view a scene of beauty and magnificence. The heavens are adorned with azure, the clouds are tinged with the most lively colors, the mountains and plains are clothed with verdure, and the whole of this lower creation stands forth arrayed with diversified scenes of beneficence and grandeur, while the contemplative eye looks round and wonders.

Such, then, are the important and beneficent effects of that *light* which every moment diffuses its blessings around us. It may justly be considered as one of the most essential substances connected with the system of the material universe, and which gives efficiency to all the other principles and arrangements, of nature. Hence we are informed, in the sacred history, that light was the first production of the Almighty Creator, and the first-born of created beings; for without it the universe would have presented nothing but an immense blank to all sentient existences. Hence, likewise, the Divine Being is metaphorically represented under the idea of *light*, as being the source of knowledge and felicity to all subordinate intelligences: "God is light, and in Him is no darkness at all;" and he is exhibited as "dwelling in light unapproachable and full of glory, whom no man hath seen or can see." In allusion to these circumstances, Milton, in his *Paradise Lost*, introduces the following beautiful apostrophe:

"Hail holy light! offspring of heaven first born,  
Or of the eternal, coeternal beam!  
May I express thee unblamed? since God is light  
And never but in unapproached light  
Dwelt from eternity; dwelt then in thee,  
Bright effluence of bright essence increate.

—Before the sun,  
Before the heavens thou wert, and at the voice  
Of God, as with a mantle, didst invest  
The rising world of waters dark and deep,  
Won from the void and formless infinite."

As light is an element of so much importance and utility in the system of nature, so we find

that arrangements have been made for its universal diffusion throughout all the worlds in the universe. The sun is one of the principal sources of light to this earth on which we dwell, and to all the other planetary bodies; and, in order that it may be *equally* distributed over every portion of the surfaces of these globes, to suit the exigencies of their inhabitants, they are endowed with a motion of rotation, by which every part of their surfaces is alternately turned toward the source of light; and when one hemisphere is deprived of the direct influence of the solar rays, its inhabitants derive a portion of light from luminaries in more distant regions, and have their views directed to other suns and systems, dispersed, in countless numbers, throughout the remote spaces of the universe. Around several of the planets, satellites or moons have been arranged for the purpose of throwing light on their surfaces in the absence of the sun, while, at the same time, the primary planets themselves reflect an effulgence of light upon their satellites. All the stars which our unassisted vision can discern in the midnight sky, and the millions more which the telescope alone enables us to descry, must be considered as so many fountains of light, not merely to illuminate the voids of immensity, but to irradiate with their beams surrounding worlds with which they are more immediately connected, and to diffuse a general luster throughout the amplitudes of infinite space; and, therefore, we have every reason to believe that, could we fly, for thousands of years, with the swiftness of a seraph, through the spaces of immensity, we should never approach a region of absolute darkness, but should find ourselves every moment encompassed with the emanations of light, and cheered with its benign influences. That Almighty Being who inhabiteth immensity and "dwells in light inaccessible," evidently appears to have diffused light over the remotest spaces of his creation, and to have thrown a radiance upon all the provinces of his wide and eternal empire, so that every intellectual being, wherever existing, may feel its beneficent effects, and be enabled, through its agency, to trace his wonderful operations, and the glorious attributes with which he is invested.

As the science of astronomy depends solely on the influence of light upon the organ of vision, which is the most noble and extensive of all our senses; and as the construction of telescopes and other astronomical instruments is founded upon our knowledge of the nature of light and the laws by which operates, it is essentially requisite, before proceeding to a description of such instruments, to take a cursory view of its nature and properties, in so far as they have been ascertained, and the effects it produces when obstructed by certain bodies, or when passing through different mediums

## CHAPTER I.

### GENERAL PROPERTIES OF LIGHT.

It is not my intention to discuss the subject of light in minute detail, a subject which is of considerable extent, and which would require a separate treatise to illustrate it in all its aspects and bearings. All that I propose is to offer a few illustrations of its general properties, and the laws by which it is refracted and reflected, so as to prepare the way for explaining the nature and construction of telescopes and other optical instruments.

There is no branch of natural science more deserving of our study and investigation than that which relates to light, whether we consider its beautiful and extensive effects, the magnificence and grandeur of the objects it unfolds to view, the numerous and diversified phenomena it exhibits, the optical instruments which a knowledge of its properties has enabled us to construct, or the daily advantages we derive, as social beings, from its universal diffusion. It air, which serves as the medium of sound and the vehicle of speech, enables us to carry on an interchange of thought and affection with our fellow-men, how much more extensively is that intercourse increased by light, which presents the images of our friends and other objects as it were immediately before us, in all their interesting forms and aspects—the speaking eye, the rosy cheeks, the benevolent smile, and the intellectual forehead. The eye, more susceptible of multifarious impressions than the other senses, “takes in at once the landscape of the world,” and enables us to distinguish, in a moment, the shapes and forms of all its objects, their relative positions, the colors that adorn them, their diversified aspect, and the motions by which they are transported from one portion of space to another. Light, through the medium of the eye, not only unfolds to us the presence of others, in all their minute modifications and peculiarities, but exhibits us to ourselves. It presents to our own vision a faithful portrait of peculiar features behind reflecting substances, without which property we should remain entirely ignorant of those traits of countenance which characterize us in the eyes of others.

But what is the nature of this substance we call *light*, which thus unfolds to us the scenes of creation? On this subject two leading opinions have prevailed in the philosophical world. One of these opinions is, that the whole sphere of the universe is filled with a subtle matter, which receives from luminous bodies an agitation which is incessantly continued, and which, by its vibratory motions, enables us to perceive luminous bodies. According to this opinion, light may be considered as analogous to sound, which is conveyed to the ear by the vibratory motions of the air. This was the hypothesis of Descartes, which was adopted, with some modifications, by the celebrated Euler, Huygens, Franklin, and other philosophers, and has been admitted by several scientific gentlemen of the present day. The other opinion is, that light consists of the emission or emanation of the particles of luminous bodies, thrown out incessantly

on all sides, in consequence of the continued agitation it experiences. This is the hypothesis of the illustrious Newton, and has been most generally adopted by British philosophers.

To the first hypothesis it is objected that, if true, “light would not only spread itself in a direct line, but its motion would be transmitted in every direction like that of sound, and would convey the impression of luminous bodies in the regions of space beyond the obstacles that intervene to stop its progress.” No wall or other opaque body could obstruct its course, if it undulated in every direction like sound; and it would be a necessary consequence, that we should have no night, nor any such phenomena as eclipses of the sun or moon, or the satellites of Jupiter and Saturn. This objection has never been very satisfactorily answered. On the other hand, Euler brings forward the following objections against the Newtonian doctrine of emanation. 1. That, were the sun emitting continually, and in all directions, such floods of luminous matter, with a velocity so prodigious, he must speedily be exhausted, or at least some alteration must, after the lapse of so many ages, be perceptible. 2. That the sun is not the only body that emits rays, but that all the stars have the same quality; and as everywhere the rays of the sun must be crossing the rays of the stars, their collision must be violent in the extreme, and that their direction must be changed by such a collision.\*

To the first of these objections it is answered, that so vast is the tenuity of light, that it utterly exceeds the power of conception; the most delicate instrument having never been certainly put in motion by the impulse of the accumulated sunbeams. It has been calculated that in the space of 385,130,000 Egyptian years (of 360 days), the sun would lose only the 1-1,217,420th of his bulk from the continual efflux of his light. And, therefore, if in 385 millions of years the sun's diminution would be so extremely small, it would be altogether insensible during the comparatively short period of five or six thousand years. To the second objection it is replied, that the particles of light are so extremely rare that their distance from one to another is incomparably greater than their diameters; that all objections of this kind vanish when we attend to the continuation of the impression upon the retina, and to the small number of luminous particles which are on that account necessary for producing constant vision. For it appears, from the accurate experiments of M. D'Arcy, that the impression of light upon the retina continues *eight-thirds*, and as a particle of light would move through 26,000 miles in that time, constant vision would be maintained by a succession of luminous particles twenty-six thousand miles distant from each other.

Without attempting to decide on the merits of these two hypotheses, I shall leave the reader to adopt that opinion which he may judge to be attended with the fewest difficulties, and proceed to

\* Letters to a German Princess, vol. i., p. 63, &c.

illustrate some of the *properties of light*; and in the discussion of this subject I shall generally adhere to the terms employed by those who have adopted the hypothesis of the *emanation of light*.

1. *Light emanates or radiates from luminous bodies in a straight line.* This property is proved by the impossibility of seeing light through bent tubes, or small holes pierced in metallic plates placed one behind another, except the holes be placed in a straight line. If we endeavor to look at the sun or a candle through the bore of a bended pipe, we cannot perceive the object, nor any light proceeding from it, but through a straight pipe the object may be perceived. This is likewise evident from the form of the rays of light that penetrate a dark room, which proceed straight forward in lines proceeding from the luminous body; and from the form of the *shadows* which bodies project that are bounded by right lines passing from the luminous body, and meeting the lines which terminate the interposing body. This property may be demonstrated to the eye by causing light to pass through small holes into a dark room filled with smoke or dust. It is to be understood, however, that in this case the rays of light are considered as passing through the same medium; for when they pass from air into water, glass, or other media, they are bent at the point where they enter a different medium, as we shall afterward have occasion to explain.

2. *Light moves with amazing velocity.* The ancients believed that it was propagated from the sun and other luminous bodies *instantaneously*; but the observations of modern astronomers have demonstrated that this is an erroneous hypothesis, and that light, like other projectiles, occupies a certain time in passing from one part of space to another. Its velocity, however, is prodigious, and exceeds that of any other body with which we are acquainted. It flies across the earth's orbit, a space of 199 millions of miles in extent, in the course of sixteen and a half minutes, which is at the rate of 192,000 miles every second, and more than a million of times swifter than a cannon ball flying with its greatest velocity. It appears from the discoveries of Dr. Bradley, respecting the aberration of the stars, that light flies from these bodies with a velocity similar, if not exactly the same; so that the light of the sun, the planets, the stars, and every luminous body in the universe is propagated with uniform velocity.\* But, if the velocity of light be so very great, it may be asked, how does it not strike against all objects with a force equal to its velocity? If the finest sand were thrown against our bodies with the hundredth part of this velocity, each grain would pierce us as certainly as the sharpest and swiftest arrows from a bow. It is a principle in mechanics that the force with which all bodies strike is in proportion to the size of these bodies, or the quantity of matter they contain, multiplied by the velocity with which they move. Therefore, if the particles of light were not almost infinitely small, they would, of necessity, prove destructive in the highest degree. If a particle of light were equal in size to the twelve hundred thousandth part of a small grain of sand—supposing light to be material—we should be no more able to withstand its force than we should that of sand shot point blank from the mouth of a cannon. Every object would be battered and perforated by such

celestial artillery, until our world were laid in ruins, and every living being destroyed. And herein are the wisdom and benevolence of the Creator displayed in making the particles of light so extremely small as to render them in some degree proportionate to the greatness of the force with which they are impelled; otherwise, all nature would have been thrown into ruin and confusion, and the great globes of the universe shattered to atoms.

We have many proofs, beside the above, that the particles of light are next to infinitely small. We find that they penetrate with facility the hardest substances, such as crystal, glass, various kinds of precious stones, and even the diamond itself, though among the hardest of stones; for such bodies could not be transparent, unless light found an easy passage through their pores. When a candle is lighted in an elevated situation, in the space of a second or two it will fill a cubical space (if there be no interruption) of two miles around it, in every direction, with luminous particles, before the least sensible part of its substance is lost by the candle: that is, it will in a short instant fill a sphere four miles in diameter, twelve and a half miles in circumference, and containing thirty-three and a half cubical miles, with particles of light; for an eye placed in any part of this cubical space would perceive the light emitted by the candle. It has been calculated that the number of particles of light contained in such a space cannot be less than *four hundred septillions*—a number which is *six billions* of times greater than the number of grains of sand which could be contained in the whole earth considered as a solid globe, and supposing each cubic inch of it to contain ten hundred thousand grains. Such is the inconceivable tenacity of that substance which emanates from all luminous bodies, and which gives beauty and splendor to the universe. This may also be evinced by the following experiment: Make a small pin-hole in a piece of black paper, and hold the paper upright facing a row of candles placed near each other, and at a little distance behind the black paper place a piece of white pasteboard. On this pasteboard the rays which flow from all the candles through the small hole in the black paper, will form as many specks of light as there are candles, each speck being as clear and distinct as if there were only one speck from a single candle. This experiment shows that the streams of light from the different candles pass through the small hole without confusion, and, consequently, that the particles of light are exceedingly small. For the same reason we can easily see through a small hole not more than 1-100th of an inch in diameter, the sky, the trees, houses, and nearly all the objects in an extensive landscape, occupying nearly an entire hemisphere, the light of all which may pass through this small aperture.

3. *Light is sent forth in all directions from every visible point of luminous bodies.* If we hold a sheet of paper before a candle, or the sun, or any other source of light, we shall find that the paper is illuminated in whatever position we hold it, provided the light is not obstructed by its edge, or by any other body. Hence, wherever a spectator is placed with regard to a luminous body, every point of that part of its surface which is toward him will be visible, when no intervening object intercepts the passage of the light. Hence, likewise, it follows that the sun illuminates not only an immense plane extending along the paths of the planets, from the one side of the orbit of Uranus to the other, but the whole of that sphere,

\* The manner in which the motion of light was discovered is explained in the author's work, entitled, "Celestial Scenery;" and the circumstances which led to the discovery of the aberration of light are stated and illustrated in his volume on the "Sidereal Heavens."

or solid space, of which the distance of Uranus is the radius. The diameter of this sphere is three thousand six hundred millions of miles, and it consequently contains about 21,000,000,000,000,000,000,000,000, or twenty-four thousand *quartillions* of cubical miles, every point of which immense space is filled with the solar beams. Not only so, but the whole cubical space which intervenes between the sun and the nearest fixed stars is more or less illuminated by his rays. For, at the distance of Sirius, or any other of the nearest stars, the sun would be visible, though only as a small, twinkling orb; and, consequently, his rays must be diffused, however faint, throughout the most distant spaces whence he is visible. The diameter of this immense sphere of light cannot be less than *forty billions* of miles, and its solid contents 33,500,000,000,000,000,000,000,000,000,000,000,000,000, or thirty-three thousand five hundred *sextillions* of cubical miles. All this immense and incomprehensible space is filled with the radiations of the solar orb; for were an eye placed in any one point of it, where no extraneous body interposed, the sun would be visible either as a large luminous orb, or as a small twinkling star. But he can be visible only by the rays he emits, and which enter the organs of vision. How inconceivably immense, then, must be the quantity of rays which are thrown off in all directions from that luminary which is the source of our day! Every star must likewise be considered as emitting innumerable streams of radiance over a space equally extensive; so that no point in the universe can be conceived where absolute darkness prevails, unless in the interior regions of planetary bodies.

4. *The effect of light upon the eye is not instantaneous, but continues for a short space of time.* This may be proved and illustrated by the following examples: if a stick, or a ball connected with a string, be whirled round in a circle, and a certain degree of velocity given it, the object will appear to fill the whole circle it describes. If a lighted firebrand be whirled round in the same rapid manner, a complete circle of light will be exhibited. This experiment obviously shows that the impression made on the eye by the light from the ball or the firebrand, when in any given point of the circle, is sufficiently lasting to remain until it has described the whole circle, and again renews its effect as often as the circular motion is continued. The same is proved by the following considerations: we are continually shutting our eyes, or winking; and, during the time our eyes are shut on such occasions, we should lose the view of surrounding objects if the impression of light did not continue a certain time while the eyelid covers the pupil; but experience proves that during such vibrations of the eyelids the light from surrounding objects is not sensibly intercepted. If we look for some time steadily at the light of a candle, and particularly if we look directly at the sun, without any interposing medium, or if we look for any considerable time at this luminary through a telescope with a colored glass interposed—in all these cases, if we shut our eyes immediately after viewing such objects, we shall still perceive a faint image of the object by the impression which its light has made upon our eyes.

“With respect to the duration of the impression of light, it has been observed that the teeth of a cogwheel in a clock were still visible in succession, when the velocity of rotation brought 246 teeth through a given fixed point in a second. In this case it is clear that if the impression made on the eye by the light reflected from any tooth

had lasted without sensible diminution for the 246th part of a second, the teeth would have formed one unbroken line, because a new tooth would have continually arrived in the place of the anterior one before its image could have disappeared. If a live coal be whirled round, it is observed that the luminous circle is complete when the rotation is performed in the 81-60th part of a second. In this instance we see that the impression was much more durable than the former. Lastly, if an observer sitting in a room, direct his sight, through a window, to any particular object out of doors, for about half a minute, and then shut his eyes and cover them with his hands, he will still continue to see the window, together with the outline of the terrestrial objects bordering on the sky. This appearance will remain for near a minute, though occasionally vanishing and changing color in a manner that brevity forbids our minutely describing. From these facts we are authorized to conclude that all impressions of light on the eye last a considerable time; that the brightest objects make the most lasting impressions; and that, if the object be very bright, or the eye weak, the impression may remain for a time so strong as to mix with and confuse the subsequent impressions made by other objects. In the last case the eye is said to be dazzled by the light.”\*

The following experiment has likewise been suggested as a proof of the impression which light makes upon the eye: If a card, on both sides of which a figure is drawn, for example, a bird and a cage, be made to revolve rapidly on the straight line which divides it symmetrically, the eye will perceive both figures at the same time, provided they return successively at the same place. M. D’Arcy found by various experiments that, in general, the impression which light produces on the eye lasts about the *eighth of a second*. M. Plateau, of Brussels, found that the impression of different colors lasted the following periods, the numbers here stated being the decimal parts of a second: flame, 0.242, or nearly one-fourth of a second; burning coal, 0.229; white, 0.182, or a little more than one-sixth of a second; blue, 0.186; yellow, 0.173; red, 0.184.

5. *Light, though extremely minute, is supposed to have a certain degree of force or momentum.* In order to prove this, the late ingenious Mr. Mitchell contrived the following experiment: He constructed a small vane in the form of a common weathercock, of a very thin plate of copper, about an inch square, and attached to one of the finest harpsichord wires about ten inches long, and nicely balanced at the other end of the wire by a grain of very small shot. The instrument had also fixed to it, in the middle, at right angles to the length of the wire, and in a horizontal direction, a small bit of a very slender sewing needle, about half an inch long, which was made magnetical. In this state the whole instrument might weigh about ten grains. The vane was supported in the manner of the needle in the mariner’s compass, so that it could turn with the greatest ease; and to prevent its being affected by the vibrations of the air, it was inclosed in a glass case or box. The rays of the sun were then thrown upon the broad part of the vane, or copper plate, from a concave mirror of about two feet diameter, which, passing through the front glass of the box, were collected into the focus of the mirror upon the copper plate. In consequence of this, the plate began to move with a slow motion of about

\* Nicholson’s Introduction to Natural Philosophy, vol. 1.

an inch in a second of time, until it had moved through a space of about two inches and a half, when it struck against the back of the box. The mirror being removed, the instrument returned to its former situation, and the rays of the sun being again thrown upon it, it again began to move, and struck against the back of the box as before. This was repeated three or four times with the same success.

On the above experiment the following calculation has been founded: if we impute the motion produced in this experiment to the impulse of the rays of light, and suppose that the instrument weighed ten grains, and acquired a velocity of one inch in a second, we shall find that the quantity of matter contained in the rays falling upon the instrument in that time amounted to no more than one twelve hundredth-millionth part of a grain, the velocity of light exceeding the velocity of one inch in a second in the proportion of about 12,000,000,000 to 1. The light, in this experiment, was collected from a surface of about three square feet, which, reflecting only about half what falls upon it, the quantity of matter contained in the rays of the sun incident upon a foot and a half of surface in one second of time, ought to be no more than the twelve hundredth-millionth part of a grain. But the density of the rays of light at the surface of the sun is greater than that at the earth in the proportion of 45,000 to 1; there ought, therefore, to issue from one square foot of the sun's surface in one second of time, in order to supply the waste of light,  $\frac{1}{35,000}$ th part of a grain of matter, that is, a little more than two grains a day, or about 4,752,000 grains, or 670 pounds avoirdupois, nearly, in 6,000 years; a quantity which would have shortened the sun's diameter no more than about ten feet, if it were formed of the density of water only.

If the above experiment be considered as having been accurately performed, and if the calculations founded upon it be correct, it appears that there can be no grounds for apprehension that the sun can ever be sensibly diminished by the immense and incessant radiations proceeding from his body on the supposition that light is a material emanation. For the diameter of the sun is no less than 880,000 miles; and, before this diameter could be shortened, by the emission of light, one English mile, it would require three millions one hundred and sixty-eight thousand years, at the rate now stated; and, before it could be shortened ten miles, it would require a period of above thirty-one millions of years. And although the sun were thus actually diminished, it would produce no sensible effect or derangement throughout the planetary system. We have no reason to believe that the system, in its present state and arrangements, was intended to endure forever; and before that luminary could be so far reduced, during one revolution of eternity, as to produce any irregularities in the system, new arrangements and modifications might be introduced by the hand of the All-wise and Omnipotent Creator. Beside, it is not improbable that a system of means is established by which the sun and all the luminaries in the universe receive back again a portion of the light which they are continually emitting, either from the planets from whose surfaces it is reflected, or from the millions of stars whose rays are continually traversing the immense spaces of creation, or from some other sources to us unknown.

6. *The intensity of light is diminished in proportion to the square of the distance from the luminous body.* Thus, a person at two feet distance from a candle, has only the fourth part of the light he

would have at one foot; at three feet distance, the ninth part; at four feet, the sixteenth part; at five feet, the twenty-fifth part; and so on for other distances. Hence the light received by the planets of the solar system decreases in proportion to the squares of the distances of these bodies from the sun. This may be illustrated by the following figure:

Fig. 1.

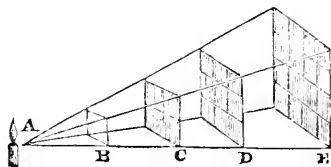

Suppose the light which flows from a point *A*, and passes through a square hole, *B*, is received upon a plane, *C*, parallel to the plane of the hole—or let the figure *C* be considered as the shadow of the plane *B*. When the distance of *C* is double of *B*, the length and breadth of the shadow, *C*, will be each double of the length and breadth of the plane *B*, and treble when *AD* is treble of *AB*, and so on, which may be easily examined by the light of a candle placed at *A*. Therefore the surface of the shadow *C*, at the distance *AC*—double of *AB*, is divisible into four squares, and, at a treble distance, into nine squares, severally equal to the square *B*, as represented in the figure. The light, then, which falls upon the plane *B* being suffered to pass to double that distance, will be uniformly spread over four times the space, and, consequently, will be four times thinner in every part of that space. And, at a treble distance, it will be nine times thinner, and, at a quadruple distance, sixteen times thinner than it was at first. Consequently, the quantities of this rarefied light received upon a surface of any given size and shape, when removed successively to their several distances, will be but one-fourth, one-ninth, one-sixteenth of the whole quantity received by it at the first distance, *AB*.

In conformity with this law, the relative quantities of light on the surfaces of the planets may be easily determined when their distances from the sun are known. Thus, the distance of Uranus from the sun is 1,800,000,000 miles, which is about nineteen times greater than the distance of the earth from the same luminary. The square of 19 is 361; consequently, the earth enjoys 361 times the intensity of light, when compared with that of Uranus; in other words, this distant planet enjoys only the  $\frac{1}{361}$  part of the quantity of light which falls upon the earth. This quantity, however, is equivalent to the light we should enjoy from the combined effulgence of 348 full moons; and if the pupils of the eyes of the inhabitants of this planet be much larger than ours, and the retina of the eye be indued with a much greater degree of nervous sensibility, they may perceive objects with as great a degree of splendor as we perceive on the objects which surround us in this world. Following out the same principle, we find that the quantity of light enjoyed by the planet Mercury is nearly seven times greater than that of the Earth, and that of Venus nearly double of what we enjoy; that Mars has less than the one-half; Jupiter the one-twenty-seventh part; and Saturn only the one-ninetieth part of the light which falls upon the Earth. That the light of these distant planets, however, is not so weak as



we might first imagine, appears from the brilliancy they exhibit, when viewed in our nocturnal sky, either with the telescope or with the unassisted eye; and likewise from the circumstance that a very small portion of the Sun—such as the one-fortieth or one-fiftieth part—diffuses a quantity of light sufficient for most of the purposes of life, as is found in the case of total eclipses of the Sun, when his western limb begins to be visible, only like a fine luminous thread, for his light is then sufficient to render distinctly visible all the parts of the surrounding landscape.

7. *It is by light reflected from opaque bodies that most of the objects around us are rendered visible.*—When a lighted candle is brought into a dark room, not only the candle, but all other bodies in the room become visible. Rays of the sun, passing into a dark room, render luminous a sheet of paper on which they fall, and this sheet, in its turn, enlightens, to a certain extent, the whole apartment, and renders objects in it visible so long as it receives the rays of the sun. In like manner, the moon and the planets are opaque bodies, but the light of the sun falling upon them, and being reflected from their surfaces, renders them visible. Were no light to fall on them from the sun, or were they not indued with a power of reflecting it, they would be altogether invisible to our sight. When the moon comes between us and the sun, as in a total eclipse of that luminary, as no solar light is reflected from the surface next the earth, she is invisible, only the curve or outline of her figure being distinguished by her shadow. In this case, however, there is a certain portion of reflected light on the lunar hemisphere next the earth, though not distinguishable during a solar eclipse. The earth is enlightened by the sun, and a portion of the rays which fall upon it is reflected upon the dark hemisphere of the moon which is then toward the earth. This reflected light from the earth is distinctly perceptible, when the moon appears as a slender crescent, two or three days after new moon—when the earth reflects its light back on the moon, in the same manner as the full moon reflects her light on the earth. Hence, even at this period of the moon, her whole face becomes visible to us, but its light is not uniform or of equal intensity. The thin crescent on which the full blaze of the solar light falls, is very brilliant and distinctly seen, while the other part, on which falls only a comparatively feeble light from the earth, appears very faint, and is little more than visible to the naked eye, but with a telescope of moderate power—if the atmosphere be very clear—it appears beautifully distinct, so that the relative positions of many of the lunar spots may be distinguished.

The intensity of reflected light is very small, when compared with that which proceeds directly from luminous bodies. M. Bouguer, a French philosopher, who made a variety of experiments to ascertain the proportion of light emitted by the heavenly bodies, concluded from these experiments, that the light transmitted from the sun to the earth is at least 300,000 times as great as that which descends to us from the full moon, and that, of 300,000 rays which the moon receives, from 170,000 to 200,000 are absorbed. Hence we find that, however brilliant the moon may appear at night, in the day-time she appears as obscure as a small portion of dusky cloud to which she happens to be adjacent, and reflects no more light than a portion of whitish cloud of the same size. And as the full moon fills only the ninety-thousandth part of the sky, it would require at least ninety thousand moons to produce as much

light as we enjoy in the day-time under a cloudy sky.

As the moon and the planets are rendered visible to us only by light reflected from their surfaces, so it is in the same way that the images of most of the objects around us are conveyed to our organs of vision. We behold all the objects which compose an extensive landscape—the hills and vales, the woods and lawns, the lakes and rivers, and the habitations of man—in consequence of the capacity with which they are indued of sending forth reflected rays to the eye, from every point of their surfaces and in all directions. In connection with the reflection of light, the following curious observation may be stated: Baron Funk, visiting some silver mines in Sweden, observed, that, “in a clear day, it was as dark as pitch under ground in the eye of a pit, at sixty or seventy fathoms deep; whereas, in a cloudy or rainy day, he could see to read even at 106 fathoms deep. Inquiring of the miners, he was informed that this is always the case; and reflecting upon it, he imagined it arose from this circumstance, that, when the atmosphere is full of clouds, light is reflected from them into the pit in all directions, and that thereby a considerable proportion of the rays are reflected perpendicularly upon the earth: whereas, when the atmosphere is clear, there are no opaque bodies to reflect the light in this manner, at least in a sufficient quantity; and rays from the sun himself can never fall perpendicularly in that country.” The reason here assigned is, in all probability, the true cause of the phenomenon now described.

8. It is supposed by some philosophers that *light is subject to the same laws of attraction that govern all other material substances, and that it is imbibed and forms a constituent part of certain bodies.* This has been inferred from the phenomena of the *Bolognian stone*, and what are generally called the *solar phosphori*. The Bolognian stone was first discovered about the year 1630, by Leascariolo, a shoemaker of Bologna. Having collected together some stones of a shining appearance at the bottom of Monte Paterno, and being in quest of some alchemical secret, he put them into a crucible to calcine them; that is, to reduce them to the state of cinders. Having taken them out of the crucible, and exposed them to the light of the sun, he afterward happened to carry them into a dark place, when, to his surprise, he observed that they possessed a self-illuminating power, and continued to emit faint rays of light for some hours afterward. In consequence of this discovery, the Bolognian spar came into considerable demand among natural philosophers, and the curious in general; and the best way of preparing it seems to have been hit upon by the family of Zagoni, who supplied all Europe with Bolognian phosphorus until the discovery of more powerful phosphoric substances put an end to their monopoly. In the year 1677, Baldwin, a native of Misnia, observed that chalk, dissolved in aquafortis, exactly resembled the Bolognian stone in its property of imbibing light, and emitting it after it was brought into the dark; and hence it has obtained the name of Baldwin's phosphorus.

In 1730 M. Du Fay directed his attention to this subject, and observed that all earthy substances susceptible of calcination, either by mere fire, or when assisted by the previous action of nitrous acid, possessed the property of becoming more or less luminous, when calcined and exposed for a short time in the light; that the most perfect of these phosphori were limestones, and other kinds of carbonated lime, gypsum, and particularly the

topaz, and that some diamonds were also observed to be luminous by simple exposure to the sun's rays. Some time afterward Beccaria discovered that a great variety of other bodies were convertible into phosphori by exposure to the mere light of the sun, such as organic animal remains, most compound salts, niter and borax—all the farinaceous and oily seeds of vegetable substances, all the gums and several of the resins—the white woods and vegetable fiber, either in the form of paper or linen; also starch and loaf-sugar proved to be good phosphori, after being made thoroughly dry, and exposed to the direct rays of the sun. Certain animal substances, by a similar treatment, were also converted into phosphori; particularly bone, sinew, glue, hair, horn, hoof, feathers, and fish-shells. The same property was communicated to rock-crystal and some other of the gems, by rubbing them against each other so as to roughen their surfaces, and then placing them for some minutes in the focus of a lens, by which the rays of light were concentrated upon them at the same time that they were also moderately heated.

In the year 1768, Mr. Canton contributed some important facts in relation to solar phosphori, and communicated a method of preparing a very powerful one, which, after the inventor, is usually called *Canton's phosphorus*. He affirms that his phosphorus, inclosed in a glass flask, and hermetically sealed, retains its property of becoming luminous for at least four years, without any apparent decrease of activity. It has also been found that, if a common box smoothing-iron, heated in the usual manner, be placed for half a minute on a sheet of dry, white paper, and the paper be then exposed to the light, and afterward examined in a dark closet, it will be found that the whole paper will be luminous, that part, however, on which the iron had stood being much more shining than the rest.

From the above facts it would seem that certain bodies have the power of imbibing light and again emitting it, in certain circumstances, and that this power may remain for a considerable length of time. It is observed that the light which such bodies emit, bears an analogy to that which they have imbibed. In general, the illuminated phosphorus is reddish; but when a weak light only has been admitted to it, or when it has been received through pieces of white paper, the emitted light is pale or whitish. Mr. Morgan, in the seventy-fifth volume of the *Philosophical Transactions*, treats the subject of light at considerable length; and as a foundation for his reasoning, he assumes the following data: 1. That light is a body, and, like all others, subject to the laws of attraction. 2. That light is a heterogeneous body, and that the same attractive power operates with different degrees of force on its different parts. To the principle of attraction, likewise, Sir Isaac Newton has referred the most extraordinary phenomena of light, Refraction and Inflection. He has also endeavored to show that light is not only subject to the law of attraction, but of repulsion also, since it is repelled or reflected from certain bodies. If such principles be admitted, then it is highly probable that the phosphorescent bodies to which we have adverted have a power of attracting or imbibing the substance of light, and of retaining or giving it out under certain circumstances, and that the matter of light is incorporated, at least, with the surface of such bodies; but on this subject, as on many others, there is a difference of opinion among philosophers.\*

9. *Light is found to produce a remarkable effect on plants and flowers, and other vegetable productions.* Of all the phenomena which living vegetables exhibit, there are few that appear more extraordinary than the energy and constancy with which their stems incline toward the light. Most of the discous flowers follow the sun in his course. They attend him to his evening retreat, and meet his rising lustre in the morning with the same unerring law. They unfold their flowers on the approach of this luminary; they follow his course by turning on their stems, and close them as soon as he disappears. If a plant, also, is shut up in a dark room, and a small hole afterward opened by which the light of the sun may enter, the plant will turn toward that hole, and even alter its own shape in order to get near it; so that though it was straight before, it will in time become crooked, that it may get near the light. Vegetables placed in rooms where they receive light only in one direction, always extend themselves in that direction. If they receive light in two directions, they direct their course toward that which is strongest. It is not the heat, but the light of the sun which the plant thus covets; for, though a fire be kept in the room, capable of giving a much stronger heat than the sun, the plant will turn away from the fire in order to enjoy the solar light. Trees growing in thick forests, where they only receive light from above, direct their shoots almost invariably upward, and therefore become much taller and less spreading than such as stand single.

The green color of plants is likewise found to depend on the sun's light being allowed to shine on them; for without the influence of the solar light they are always of a white color. It is found by experiment that, if a plant which has been reared in darkness be exposed to the light of day, in two or three days it will acquire a green color perceptibly similar to that of plants which have grown in open daylight. If we expose to the light one part of the plant, whether leaf or branch, this part alone will become green. If we cover any part of a leaf with an opaque substance, this place will remain white, while the rest becomes green. The whiteness of the inner leaves of cabbages is a partial effect of the same cause, and many other examples of the same kind might easily be produced. M. Decandolle, who seems to have paid

superstition, served to astonish and afflict the timorous.—We learn from Fabricius, an Italian, that three young men, residing at Padua, having bought a lamb, and eaten part of it on Easter day, 1392, several pieces of the remainder, which they kept until the following day, shone like so many candles when they were casually viewed in the dark. The astonishment of the whole city was excited by this phenomenon, and a part of the flesh was sent to Fabricius, who was professor of anatomy, to be examined by him. He observed that those parts which were soft to the touch and transparent in candle-light were the most resplendent; and also that some pieces of kid's flesh which had happened to have laid in contact with them were luminous, as well as the fingers and other parts of the bodies of those persons who touched them. Bartholin gives an account of a similar phenomenon, which happened in Montpellier, in 1641.—A poor woman had bought a piece of flesh in the market, intending to make use of it on the following day; but happening not to be able to sleep well that night, and her bed and pantry being in the same room, she observed so much light come from the flesh as to illuminate all the place where it hung. We may judge of the terror and astonishment of the woman herself, when we find that a part of this luminous flesh was carried as a very extraordinary curiosity to Henry, duke of Conde, the governor of the place, who viewed it several hours with the greatest astonishment. The light was as if gems had been scattered over the surface, and continued until the flesh began to putrefy, when it vanished, which it was believed to do in the form of a cross. Hence the propriety of instructing the mass of the community in the knowledge of the facts connected with the material system, and the physical causes of the various phenomena of nature.

\* Light of a phosphoric nature is frequently emitted from various putrescent animal substances, which, in the ages of

particular attention to this subject, has the following remarks: "It is certain, that between the white state of plants vegetating in darkness, and complete verdure, every possible intermediate degree exists, determined by the intensity of the light. Of this any one may easily satisfy himself by attending to the color of a plant exposed to the full daylight; it exhibits in succession all the degrees of verdure. I had already seen the same phenomenon, in a particular manner, by exposing plants reared in darkness to the light of lamps. In these experiments, I not only saw the color come on gradually, according to the continuance of the exposure to light, but I satisfied myself that a certain intensity of permanent light never gives to a plant more than a certain degree of color. The same fact readily shows itself in nature, when we examine the plants that grow under shelter or in forests, or when we examine in succession the state of the leaves that form the heads of cabbages."\*

It is likewise found that the *perspiration* of vegetables is increased or diminished in a certain measure by the degree of light which falls upon them. The experiments of Mr. P. Miller, and others, prove that plants uniformly perspire most in the forenoon, though the temperature of the air in which they are placed should be unvaried. M. Guettard likewise informs us that a plant exposed to the rays of the sun has its perspiration increased to a much greater degree than if it had been exposed to the same heat under the shade. Vegetables are likewise found to be indebted to light for their smell, taste, combustibility, maturity, and the resinous principle, which equally depend upon this fluid. The aromatic substances, resins, and volatile oils, are the productions of southern climates, where the light is more pure, constant, and intense. In fine, another remarkable property of light on the vegetable kingdom is, that, when vegetables are exposed to open daylight, or to the sun's rays, they emit oxygen gas, or vital air. It has been proved that, in the production of this effect, the sun does not act as a body that heats. The emission of the gas is determined by the light: pure air is therefore separated by the action of light, and the operation is stronger as the light is more vivid. By this continual emission of vital air, the Almighty incessantly purifies the atmosphere, and repairs the loss of pure air occasioned by respiration, combustion, fermentation, putrefaction, and numerous other processes which have a tendency to contaminate this fluid, so essential to the vigor and comfort of animal life; so that, in this way, by the agency of light, a due equilibrium is always maintained between the constituent parts of the atmosphere.

In connection with this subject the following curious phenomenon may be stated, as related by M. Haggern, a lecturer on Natural History in Sweden. One evening he perceived a faint flash of light repeatedly dart from a marigold. Surprised at such an uncommon appearance, he resolved to examine it with attention; and, to be assured it was no deception of the eye, he placed a man near him, with orders to make a signal at the moment when he observed the light. They both saw it constantly at the same moment. The light was most brilliant on marigolds of an orange or flame color, but scarcely visible on pale ones. The flash was frequently seen on the same flower two or three times in quick succession, but more commonly at intervals of several minutes; and when several flowers in the same place emitted

their light together, it could be observed at a considerable distance. The phenomenon was remarked in the months of July and August at sunset, and for half an hour when the atmosphere was clear; but after a rainy day, or when the air was loaded with vapors, nothing of it was seen. The following flowers emitted flashes more or less vivid, in this order: 1. The Marigold. 2. Monk's Hood. 3. The Orange Lily. 4. The Indian Pink. As to the *cause* of this phenomenon, different opinions may be entertained. From the rapidity of the flash and other circumstances, it may be conjectured that electricity is concerned in producing this appearance. M. Haggern, after having observed the flash from the orange lily, the antheræ of which are at considerable distance from the petals, found that the light proceeded from the petals only; whence he concludes that this electrical light is caused by the pollen, which, in flying off, is scattered on the petals. But, perhaps, the true cause of it still remains to be ascertained.

10. *Light has been supposed to produce a certain degree of influence on the propagation of sound.* M. Parolette, in a long paper in the "Journal de Physique," vol. 68, which is copied into "Nicholson's Philosophical Journal," vol. 25, pp. 29-39, has offered a variety of remarks, and detailed a number of experiments on this subject. The author states the following circumstances as having suggested the connection between light and sound: "In 1803 I lived in Paris, and being accustomed to rise before day to finish a work on which I had long been employed, I found myself frequently disturbed by the sound of carriages, as my windows looked into one of the most frequented streets in that city. This circumstance, which disturbed me in my studies every morning, led me to remark that the appearance of daybreak peculiarly affected the propagation of the sound; from dull and deep, which it was before day, it seemed to me to acquire a more sonorous sharpness in the period that succeeded the dissipation of darkness. The rolling of the wheels seemed to announce the friction of some substances grown more elastic; and my ear, on attending to it, perceived this difference diminish in proportion as the sound of wheels was confounded with those excited by the tumult of objects quitting their nocturnal silence. Struck with this observation, I attempted to discover whether any particular causes had deceived my ears. I rose several times before day for this purpose alone, and was every time confirmed in my suspicion that light must have a peculiar influence on the propagation of sound. This variation, however, in the manner in which the air gave sounds, might be the effect of the agitation of the atmosphere produced by the rarefaction the presence of the sun occasioned; but the situation of my windows, and the usual direction of the morning breeze, militated against this argument."

The author then proceeds to give a description of a very delicate instrument, and various apparatus for measuring the propagation and intensity of sound, and the various experiments both in the dark and in daylight, and likewise under different changes of the atmosphere, which were made with his apparatus, all of which tended to prove that light had a sensible influence in the propagation of sound. But the detail of these experiments, and their several results, would be too tedious to be here transcribed. The night has generally been considered as more favorable than the day for the transmission of sound. "That this is the case," says Parolette, "with respect to our

\* Memoires de la Soc. d Aroncil, vol. ii.

ears cannot be doubted: but this argues nothing against my opinion. We hear farther by night on account of the silence, and this always contributes to it, while the noise of a wind favorable to the propagation of a sound may prevent the sound from being heard." In reference to the cause which produces the effect now stated, he proposes the following queries: "Is the atmospheric air more dense on the appearance of light than in darkness? Is this greater density of the air, or of the elastic fluid that is subservient to the propagation of sound, the effect of aeriform substances kept in this state through the medium of light?" He is disposed, on the whole, to conclude that the effect in question is owing to the action of light upon the oxygen of the atmosphere, since oxygen gas is found by experiment to be best adapted to the transmission of sound.

Our author concludes his communication with the following remarks: "Light has a velocity 900,000 times as rapid as that of sound. Whether it emanate from the sun and reach to our earth, or act by means of vibrations agitating the particles of a fluid of a peculiar nature, the particles of this fluid must be extremely light, elastic, and active. Nor does it appear to me unreasonable to ascribe to the mechanical action of these particles set in motion by the sun, the effects its presence occasions in the vibrations that proceed from sonorous bodies. The more deeply we investigate the theory of light, the more we must perceive that the powers by which the universe is moved reside in the imperceptible particles of bodies; and that the grand results of nature are but an assemblage of an order of actions that take place in its infinitely small parts; consequently, we cannot institute a series of experiments more interesting than those which tend to develop the properties of light. Our organs of sense are so immediately connected with the fluid that enlightens us, that a notion of having acquired an idea of the mode of action of this fluid presents itself to our minds, as the hope of a striking advance in the knowledge of what composes the organic mechanism of our life, and of that of beings which closely follow the rank assigned to the human species."

Such is a brief description of some of the leading properties of light. Of all the objects that present themselves to the philosophic and contemplative mind, light is one of the noblest and most interesting. The action it exerts on all the combinations of matter, its extreme divisibility, the rapidity of its propagation, the sublime wonders it reveals, and the office it performs in what constitutes the life of organic beings, lead us to consider it as a substance acting the first part in the economy of nature. The magic power which this emanation from the heavens exerts on our organs of vision, in exhibiting to our view the sublime spectacle of the universe, cannot be sufficiently admired. Nor is its power confined to the organs of sight; all our senses, are, in a greater or less degree, subjected to the action of light, and all the objects in this lower creation—whether in the animal, the vegetable, or the mineral kingdoms—are, to a certain extent, susceptible of its influence. Our globe appears to be little more than an accumulation of terrestrial materials introduced into the boundless ocean of the *solar light*, as a theater on which it may display its exhaustless power and energy, and give animation, beauty, and sublimity to every surrounding scene, and to regulate all the powers of nature, and render them subservient to the purposes for which they were ordained. This elementary substance appears to be universal in its movements and in its influence.

It descends to us from the solar orb. It wings its way through the voids of space, along a course of ninety-five millions of miles, until it arrives at the outskirts of our globe; it passes freely through the surrounding atmosphere; it strikes upon the clouds, and is reflected by them; it irradiates the mountains, the vales, the forests, the rivers, the seas, and all the productions of the vegetable kingdom, and adorns them with a countless assemblage of colors. It scatters and disperses its rays from one end of creation to another, diffusing itself throughout every sphere of the universe. It flies without intermission from star to star, and from suns to planets, throughout the boundless sphere of immensity, forming a connecting chain and a medium of communication among all the worlds and beings within the wide empire of Omnipotence.

When the sun is said "to rule over the day," it is intimated that he acts as the vicegerent of the Almighty, who has invested him with a mechanical power of giving light, life, and motion to all the beings susceptible of receiving impressions from his radiance. As the servant of his Creator, he distributes blessings without number among all the tribes of sentient and intelligent existence. When his rays illumine the eastern sky in the morning, all nature is enlivened with his presence. When he sinks beneath the western horizon, the flowers droop, the birds retire to their nests, and a mantle of darkness is spread over the landscape of the world. When he approaches the equinox in spring, the animal and vegetable tribes revive and nature puts on a new and a smiling aspect. When he declines toward the winter solstice, dreariness and desolation ensue, and a temporary death takes place among the tribes of the vegetable world. This splendid luminary, whose light embellishes the whole of this lower creation, forms the most lively representation of Him who is the source and the center of all beauty and perfection. "God is a sun," the sun of the moral and spiritual universe, from whom all the emanations of knowledge, love, and felicity descend. "He covereth himself with light as with a garment," and "dwells in light inaccessible and full of glory." The felicity and enjoyments of the future world are adumbrated under the ideas of *light* and *glory*. "The glory of God enlightens the celestial city;" its inhabitants are represented as "the saints in light;" it is declared that "their sun shall no more go down," and that "the Lord God is their everlasting light." So that light not only cheers and enlivens all beings throughout the material creation, but is the emblem of the Eternal Mind, and of all that is delightful and transporting in the scenes of a blessed immortality.

In the formation of light, and the beneficent effects it produces, the wisdom and goodness of the Almighty are conspicuously displayed. Without the beams of the sun and the influence of light, what were all the realms of this world but an undistinguished chaos and so many dungeons of darkness? In vain should we roll our eyes around to behold, amid the universal gloom, the flowery fields, the verdant plains, the flowing streams, the expansive ocean, the moon walking in brightness, the planets in their courses, or the innumerable host of stars. All would be lost to the eye of man, and the "blackness of darkness" would surround him forever. And with how much wisdom has everything been arranged in relation to the motions and minuteness of light? Were it capable of being transformed into a solid substance, and retain its present velocity, it would form the most dreadful and appalling element in nature, and produce

universal terror and destruction throughout the universe. That this is not impossible, and could easily be effected by the hand of Omnipotence, appears from such substances as *phosphorus*, where light is supposed to be concentrated in a solid state. But in all its operations and

effects, as it is now directed by unerring wisdom and beneficence, it exhibits itself as the most benign and delightful element connected with the constitution of the material system, diffusing splendor and felicity wherever its influence extends.

## CHAPTER V.

## ON THE REFRACTION OF LIGHT.

REFRACTION is the turning or bending of the rays of light out of their natural course.

Light, when proceeding from a luminous body—without being reflected from any opaque substance or inflected by passing near one—is invariably found to proceed in straight lines without the least deviation. But if it happens to pass obliquely from one medium to another, it always leaves the direction it had before and assumes a new one. This change of direction, or *bending* of the rays of light is what is called *Refraction*—a term which probably had its origin from the broken appearance which a staff or a long pole exhibits when a portion of it is immersed in water—the word, derived from the Latin *frango*, literally signifying *breaking* or bending.

When light is thus refracted, or has taken a new direction, it then proceeds invariably in a straight line until it meets with a different medium,\* when it is again turned out of its course. It must be observed, however, that though we may by this means cause the rays of light to make any number of angles in their course, it is impossible for us to make them describe a curve, except in one single case, namely, where they pass through a medium, the density of which either uniformly increases or diminishes. This is the case with the light of the celestial bodies, which passes downward through our atmosphere, and likewise with that which is reflected upward through it by terrestrial objects. In both these cases it describes a curve of the hyperbolic kind; but at all other times it proceeds in straight lines, or in what may be taken for straight lines without any sensible error.

There are two circumstances essential to refraction. 1. That the rays of light shall pass out of one medium into another of a different density, or of a greater or less degree of resistance. 2. That they pass in an *oblique* direction. The denser the refracting medium, or that into which the ray enters, the greater will be its refracting power; and of two refracting mediums of the same density, that which is of an oily or inflammable nature will have a greater refracting power than the other. The nature of refraction may be more particularly explained and illustrated by the following figure and description:

Let  $A D H I$ , fig. 2, be a body of water,  $A D$  its surface,  $C$  a point in which a ray of light,  $B C$ , enters from the air into the water. This ray, by the greater density of the water, instead of passing straight forward in its first direction to  $K$ , will be bent at the point  $C$ , and pass along in the

direction  $C E$ , which is called the *refracted* ray. Let the line  $F G$  be drawn perpendicular to the surface of the water in  $C$ , then it is evident that the ray  $B C$ , in passing out of air, a *rare* medium, into a *dense* medium, as water, is refracted into a ray  $C E$ , which is *nearer* to the perpendicular  $C G$  than the incident ray  $B C$  and, on the contrary, the ray  $E C$ , passing out of a denser medium into a rarer, will be refracted into  $C B$ , which is *farther* from the perpendicular.

Fig. 2.

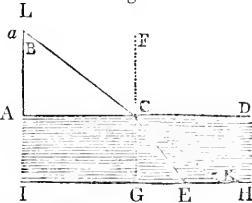

The same thing may be otherwise illustrated as follows: Suppose a hole made in one of the sides of the vessel as at  $a$ , and a lighted candle placed within two or three feet of it, when empty, so that its flame may be at  $L$ , a ray of light proceeding from it will pass through the hole,  $a$ , in a straight line,  $L B C K$ , until it reach the bottom of the vessel at  $K$ , where it will form a small circle of light. Having put a mark at the point  $K$ , pour water into the vessel until it rise to the height  $A D$ , and the round spot that was formerly at  $K$  will appear at  $E$ ; that is, the ray which went straight forward, when the vessel was empty, to  $K$ , has been bent at the point  $C$ , where it falls into the water, into the line  $C E$ . In this experiment it is necessary that the front of the vessel should be of glass, in order that the course of the ray may be seen; and if a little soap be mixed with the water so as to give it a little mistiness, the ray  $C E$  will be distinctly perceived. If, in place of fresh water, we pour in salt water, it will be found that the ray  $B C$  is more bent at  $C$ . In like manner, alcohol will refract the ray  $B C$  more than salt water, and oil more than alcohol, and a piece of solid glass, of the shape of the water, would refract the light still more than the oil.

The angle of refraction depends on the obliquity of the rays falling on the refracting surface being always such, that the sine of the incident angle is to the sine of the refracted angle in a given proportion. The *incident* angle is the angle made by a ray of light and a line drawn perpendicular to the refracting surface, at the point where the light enters the surface. The *refracted* angle is the angle made by the ray in the refracting medium with the same perpendicular produced. The *sine* of the angle is a line which serves to measure the angle, being drawn from a point in one leg perpendicular to the other. The following figure (fig. 3) will tend to illustrate these definitions.

\* By a *medium*, in optics, is meant the space in which a ray of light moves, whether pure space, air, water, glass, diamond, or any other transparent substance through which the rays of light can pass in straight lines.

In this figure,  $BC$  is the incident ray,  $CE$  the refracted ray,  $DG$  the perpendicular,  $AD$  the sine of the angle of incidence,  $ACD$ , and  $HR$  the sine of the angle of refraction  $GCE$ . Now,

Fig. 3.

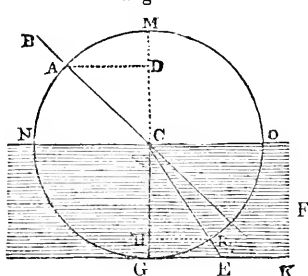

it is a proposition, in optics, that the sine  $AD$  of the angle of incidence  $BCD$  is either accurately or very nearly in a given proportion to the sine  $HR$  of the angle of refraction  $GCE$ . This ratio of the sines is as four to three, when the refraction is made out of air into water, that is,  $AD$  is to  $HR$  as four to three. When the refraction is out of air into glass, the proportion is about as thirty-one to twenty, or nearly as three to two. If the refraction be out of air into diamond, it is as five to two, that is  $AD : HR : : 5 : 2$ . The denser the medium is, the less is the angle and sine of refraction. If a ray of light,  $MC$ , were to pass from air into water, or from empty space into air, in the direction  $MC$ , perpendicular to the plane  $NO$ , which separates the two mediums, it would suffer no refraction, because one of the essentials to that effect is wanting, namely, the obliquity of the incidence.

It may also be proper to remark that a ray of light cannot pass out of a denser medium into a rarer, if the angle of incidence exceed a certain limit. Thus a ray of light will not pass out of glass into air, if the angle of incidence exceed  $40^\circ 11'$ ; or out of glass into water, if the angle of incidence exceed  $59^\circ 20'$ . In such cases refraction will be changed into reflection.

The following common experiments, which are easily performed, will illustrate the doctrine of refraction: Put a shilling, or any other small object which is easily distinguished, into a basin or any other similar vessel, and then retire to such a distance as that the edge of the vessel shall just hide it from your sight. If then you cause another person to fill the vessel with water, you will find that the shilling is rendered perfectly visible, although you have not in the slightest degree changed your position. The reason of this is, that the rays of light, by which it is rendered visible are bent out of their course. Thus, suppose the shilling to have been placed at the bottom of the basin at  $E$  (fig. 2), the ray of light  $BC$  which passes obliquely from the air into water at  $C$ , instead of continuing its course to  $K$ , takes the direction of  $CE$ , and, consequently, an object at  $E$  would be rendered visible by rays proceeding in that direction, when they would not have touched it had they proceeded in their direct course.

The same principle is illustrated by the following experiment: Place a basin or square box on a table, and a candle at a small distance from it; lay a small rod or stick across the sides of the basin, and mark the place where the extremity of the shadow falls, by placing a shilling or other object

at the point; then let water be poured into the basin, and the shadow will then fall much nearer to the side next the candle than before. This experiment may likewise be performed by simply observing the change produced on the shadow of the side of the basin itself. Again, put a long stick obliquely into deep water, and the stick will seem to be broken at the point where it appears at the surface of the water, the part which is immersed in the water appearing to be bent upward. Hence every one must have observed that in rowing a boat the ends of the oars appear bent or broken every time they are immersed in the water, and their appearance at such times is a representation of the course of the refracted rays. Again, fill a pretty deep jar with water, and you will observe the bottom of the jar considerably elevated, so that it appears much shallower than it did before the water was poured in, in the proportion of nearly a third of its depth which is owing to the same cause as that which makes the end of a stick immersed in water appear more elevated than it would do if there were no refraction. Another experiment may be just mentioned. Put a sixpence in a wine-glass, and pour upon it a little water. When viewed in a certain position, two sixpences will appear in the glass—one image of the sixpence from below, which comes directly to the eye, and another which appears considerably raised above the other, in consequence of the rays of light rising through the water, and being refracted. In this experiment the wine-glass should not be more than half filled with water.

The refraction of light explains the causes of many curious and interesting phenomena both in the heavens and on the earth. When we stand on the banks of a river, and look obliquely through the waters to its bottom, we are apt to think it is much shallower than it really is. If it be eight feet deep in reality, it will appear from the bank to be only six feet; if it be five feet and a half deep, it will appear only about four feet. This is owing to the effects of refraction, by which the bottom of the river is apparently raised by the refraction of the light passing through the water into air, so as to make the bottom appear higher than it really is, as in the experiment with the jar of water. This is a circumstance of some importance to be known and attended to in order to personal safety; for many school-boys and other young persons have lost their lives by attempting to ford a river, the bottom of which appeared to be within their reach when they viewed it from its banks; and even adult travellers on horseback have sometimes fallen victims to this optical deception; and this is not the only case in which a knowledge of the laws of nature may be useful in guarding us against dangers and fatal accidents.

It is likewise owing to this refractive power in water that a skillful marksman, who wishes to shoot fish under water, is obliged to take aim considerably below the fish as it appears, because it seems much nearer the top of the water than it really is. An acquaintance with this property of light is particularly useful to divers, for, in any of their movements or operations, should they aim directly at the object, they would arrive at a point considerably beyond it; whereas, by having some idea of the depth of the water, and the angle which a line drawn from the eye to the object makes with its surface, the point at the bottom of the water, between the eye and the object at which the aim is to be taken, may be easily determined. For the same reason, a person below water does not see objects distinctly. For, as the aqueous humor of the eye has the same refrac-

five power as water, the rays of light from any object under water will undergo no refraction in passing through the cornea and aqueous humor, and will therefore meet in a point far beyond the retina. But if any person, accustomed to go below water, should use a pair of spectacles, consisting of two convex lenses, the radius of whose surface is three-tenths of an inch—which is nearly the radius of the convexity of the cornea—he will see objects as distinctly below water as above it.

It is owing to refraction that we cannot judge so accurately of magnitudes and distances in water as in air. A fish looks considerably larger in water than when taken out of it. An object plunged vertically into water always appears contracted, and the more so as its upper extremity approaches nearer the surface of the water. Everything remaining in the same situation, if we take the object gradually out of the water, and it be of a slender form, we shall see it become larger and larger, by a rapid development, as it were, of all its parts. The distortion of objects, seen through a crooked pane of glass in a window, likewise arises from its unequal refraction of the rays that pass through it. It has been calculated that, in looking through the common glass of a window, objects appear about the one-thirtieth of an inch out of their real place, by means of the refraction.

Refraction likewise produces an effect upon the heavenly bodies, so that their apparent positions are generally different from their real. By the refractive power of the atmosphere the sun is seen before he comes to the horizon in the morning, and after he sinks beneath it in the evening; and hence this luminary is never seen in the place in which it really is, except when it passes the zenith at noon, to places within the torrid zone. The sun is visible when actually thirty-two minutes of a degree below the horizon, and when the opaque rotundity of the earth is interposed between our eye and that orb, just on the same principle as, in the experiment with the shilling and basin of water, the shilling was seen when the edge of the basin interposed between it and the sight. The refractive power of the atmosphere has been found to be much greater in certain cases, than what has been now stated. In the year 1595, a company of Dutch sailors having been wrecked on the shores of Nova Zembla, and having been obliged to remain in that desolate region during a night of more than three months, beheld the sun make his appearance in the horizon about sixteen days before the time in which he should have risen according to calculation, and when his body was actually more than four degrees below the horizon; which circumstance has been attributed to the great refractive power of the atmosphere in those intensely cold regions. This refraction of the atmosphere, which renders the apparent rising and setting of the sun both earlier and later than the real, produces, at least, one important beneficial effect. It procures for us the benefit of a much longer day, at all seasons of the year, than we should enjoy did not this property of the atmosphere produce this effect. It is owing to the same cause that the discs of the sun and moon appear elliptical or oval when seen in the horizon, their horizontal diameters appearing longer than their vertical, which is caused by the greater refraction of the rays coming from the lower limb, which is immersed in the densest part of the atmosphere.

The illumination of the heavens which precedes the rising of the sun, and continues some time after he is set, or what is commonly called the morning and evening twilight, is likewise produced

by the atmospherical refraction, which circumstance forms a very pleasing and beneficial arrangement in the system of nature. It not only prolongs to us the influence of the solar light, and adds nearly two hours to the length of our day, but prevents us from being transported all at once from the darkness of midnight to the splendor of noonday, and from the effulgence of day to the gloom and horrors of the night, which would bewilder the traveler and navigator in their journeys by sea or land, and strike the living world with terror and amazement.

The following figure will illustrate the position now stated, and the manner in which the refraction of the atmosphere produces these effects: Let  $A a C$ , fig. 4, represent one-half of our globe, and the dark space between that curve and  $B r D$ , the atmosphere. A person standing on the earth's surface at  $a$  would see the sun rise at  $b$ , when that luminary was in reality only at  $c$ , more than half a degree below the horizon. When the rays

Fig. 4.

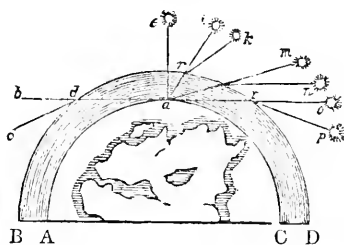

of the sun, after having proceeded in a straight line through empty space, strike the upper part of the atmosphere at the point  $d$ , they are bent out of their right-lined course by the refraction of the atmosphere, into the direction  $d a$ , so that the body of the sun, though actually intercepted by the curve of the earth's convexity, consisting of a dense mass of land or water, is actually beheld by the spectator at  $a$ . The refractive power of the atmosphere gradually diminishes from the horizon to the zenith, and increases from the zenith to the horizon, in proportion to the density of its different strata, being densest at its lower extremity next the earth, and more rare toward its higher regions. If a person at  $a$  had the sun,  $e$ , in his zenith, he would see him where he really is; for his rays coming perpendicularly through the atmosphere, would be equally attracted in all directions, and would, therefore, suffer no inflection. But, about two in the afternoon, he would see the sun at  $i$ , though, in reality, he was at  $k$ , thirty-three seconds lower than his apparent situation. At about four in the afternoon he would see him at  $m$ , when he is at  $n$ , one minute and thirty-eight seconds from his apparent situation. But at six o'clock, when we shall suppose he sets, he will be seen at  $o$ , though he is at that time at  $p$ , more than thirty-two minutes below the horizon. These phenomena arise from the different refractive powers of the atmosphere at different elevations, and from the obliquity with which the rays of light fall upon it; for we see every object along that line in which the rays from it are directed by the last medium through which they passed.

The same phenomena happen in relation to the moon, the planets, the comets, the stars, and every other celestial body, all of which appear more elevated, especially when near the horizon, than their true places. The variable and increasing refraction from the zenith to the horizon is a

source of considerable trouble and difficulty in making astronomical observations, and in nautical calculations; for, in order to determine the real altitudes of the heavenly bodies, the exact degree of refraction at the observed elevation must be taken into account. To the same cause we are to ascribe a phenomenon that has sometimes occurred, namely, that the moon has been seen rising totally eclipsed, while the sun was still visible in the opposite quarter of the horizon. At the middle of a total eclipse of the moon, the sun and moon are in opposition, or 180 degrees asunder; and, therefore, were no atmosphere surrounding the earth, these luminaries, in such a position, could never be seen above the horizon at the same time. But, by the refraction of the atmosphere near the horizon, the bodies of the sun and moon are raised more than 32 minutes above their true places, which is equal, and sometimes more than equal, to the apparent diameters of these bodies.

EXTRAORDINARY CASES OF REFRACTION IN RELATION TO TERRESTRIAL OBJECTS.

In consequence of the accidental condensation of certain strata of the atmosphere, some very singular effects have been produced in the apparent elevation of terrestrial objects to a position much beyond that in which they usually appear. The following instance is worthy of notice. It is taken from the Philosophical Transactions of London for 1798, and was communicated by W. Latham, Esq., F. R. S., who observed the phenomenon from Hastings, on the south coast of England: "On July 26, 1797, about five o'clock in the afternoon, as I was sitting in my dining-room in this place, which is situated upon the Parade, close to the seashore, nearly fronting the south, my attention was excited by a number of people running down to the seaside. Upon inquiring the reason, I was informed that the coast of France was plainly to be distinguished by the naked eye. I immediately went down to the shore, and was surprised to find that, even without the assistance of a telescope, I could very plainly see the cliffs on the opposite coast, which, at the nearest part, are between forty and fifty miles distant, and are not to be discerned from that low situation by the aid of the best glasses. They appeared to be only a few miles off, and seemed to extend for some leagues along the coast. I pursued my walk along the shore eastward, close to the water's edge, conversing with the sailors and fishermen upon the subject. They at first would not be persuaded of the reality of the appearance; but they soon became so thoroughly convinced by the cliffs gradually appearing more elevated, and approaching nearer, as it were, that they pointed out and named to me the different places they had been accustomed to visit, such as the Bay, the Old Head, or Man, the Windmill, &c., at Bologne, St. Vallery, and other places on the coast of Picardy, which they afterward confirmed, when they viewed them through their telescopes. Their observations were, that the places appeared as near as if they were sailing, at a small distance, into the harbors. The day on which this phenomenon was seen was extremely hot; it was high water at Hastings about two o'clock, P. M., and not a breath of wind was stirring the whole day." From the summit of an adjacent hill, a most beautiful scene is said to have presented itself. At one glance the spectators could see Dungeness, Dover Cliffs, and the French coast, all along from Calais to St. Vallery, and, as some affirmed, as far to the westward as

Dieppe, which could not be much less than eighty or ninety miles. By the telescope the French fishing-boats were plainly seen at anchor, and the different colors of the land on the heights, with the buildings, were perfectly discernible.

This singular phenomenon was doubtless occasioned by an extraordinary refraction, produced by an unusual expansion or condensation of the lower strata of the atmosphere, arising from circumstances connected with the extreme heat of the season. The objects seem to have been apparently raised far above their natural positions; for, from the beach at Hastings, a straight line drawn across toward the French coast, would have been intercepted by the curve of the waters. They seem, also, to have been magnified by the refraction, and brought, apparently, four or five times nearer the eye, than in the ordinary state of the atmosphere.

The following are likewise instances of unusual refraction: When Captain Colby was ranging over the coast of Caithness, with the telescope of his great Theodolite, on the 21st of June, 1819, at 8 o'clock, P. M., from Corryhabbie Hill, near Mortlich, in Banffshire, he observed a brig over the land of Caithness, sailing to the westward in the Pentland Frith, between the Dunnet and Duncansby heads. Having satisfied himself as to the fact, he requested his assistants, Lieutenants Robb and Dawson, to look through the telescope, which they immediately did, and observed the brig likewise. It was very distinctly visible for several minutes, while the party continued to look at it, and to satisfy themselves as to its position. The brig could not have been less than from ninety to one hundred miles distant; and, as the station on Corryhabbie is not above 850 yards above the sea, the phenomenon is interesting. The thermometer was at 44°. The night and day preceding the sight of the brig had been continually rainy and misty, and it was not until seven o'clock of the evening of the 21st that the clouds cleared off the hill.\*

Captain Scoresby relates a singular phenomenon of this kind, which occurred while he was traversing the Polar seas. His ship had been separated by the ice from that of his father for a considerable time, and he was looking out for her every day with great anxiety. At length, one evening, to his utter astonishment, he saw her suspended in the air, in an inverted position, traced on the horizon in the clearest colors, and with the most distinct and perfect representation. He sailed in the direction in which he saw this visionary phenomenon, and actually found his father's vessel by its indication. He was divided from him by immense masses of icebergs, and at such a distance that it was quite impossible to have seen the ship in her actual situation, or to have seen her at all, if her spectrum had not been thus raised several degrees above the horizon into the sky by this extraordinary refraction. She was reckoned to be seventeen miles beyond the visible horizon, and thirty miles distant.

Mrs. Somerville states that a friend of hers, while standing on the plains of Hindostan, saw the whole upper chain of the Himalaya Mountains start into view, from a sudden change in the density of the air, occasioned by a heavy shower, after a long course of dry and hot weather. In looking at distant objects through a telescope, over the top of a ridge of hills, about two miles distant, I have several times observed that some

\* Edinburgh Philosophical Journal for October 1819, p. 411.



of the more distant objects which are sometimes hid by the interposition of a ridge of hills, are at other times distinctly visible above them. I have sometimes observed that objects near the middle of the field of view of a telescope, which was in a fixed position, have suddenly appeared to descend to the lower part, or ascend to the upper part of the field, while the telescope remained unaltered. I have likewise seen, with a powerful telescope, the Bell Rock Lighthouse, at the distance of about twenty miles, to appear as if contracted to less than two-thirds of its usual apparent height, while every part of it was quite distinct and well-defined, and in the course of an hour, or less, appeared to shoot up to its usual apparent elevation—all which phenomena are evidently produced by the same cause to which we have been adverting.

Such are some of the striking effects produced by the refraction of light. It enables us to see objects in a direction where they are not; it raises, apparently, the bottoms of lakes and rivers; it magnifies objects when their light passes through dense mediums; it makes the sun appear above the horizon when he is actually below it, and thus increases the length of our day; it produces the Aurora and the evening twilight, which forms, in many instances, the most delightful part of a summer day; it prevents us from being involved in total darkness, the moment after the sun has descended beneath the horizon; it modifies the appearances of the celestial bodies, and the directions in which they are beheld; it tinges the sun, moon, and stars, as well as the clouds, with a ruddy hue when near the horizon; it elevates the appearance of terrestrial objects, and, in certain extraordinary cases, brings them nearer to our view, and enables us to behold them when beyond the line of our visible horizon. In combination with the power of reflection, it creates visionary landscapes, and a variety of grotesque and extraordinary appearances, which delight and astonish, and sometimes appall the beholders. In short, as we shall afterward see more particularly, the refraction of light through glasses of different figures forms the principle on which telescopes and microscopes are constructed, by which both the remote and the minute wonders of creation have been disclosed to view. So that, had there been no bodies capable of refracting the rays of light, we should have remained forever ignorant of many sublime and august objects in the remote regions of the universe, and of the admirable mechanism and the countless variety of minute objects which lie beyond the range of the unassisted eye in our lower creation, all of which are calculated to direct our views, and to enlarge our conceptions of the Almighty Creator.

In the operation of the law of refraction in these and numerous other instances, we have a specimen of the diversified and beneficent effects which the Almighty can produce by the agency of a single principle in nature. By the influence of the simple law of gravitation the planets are retained in their orbits, the moon directed in her course around the earth, and the whole of the bodies connected with the sun preserved in one harmonious system. By the same law the mountains of our globe rest on a solid basis, the rivers flow through the plains toward the seas, the ocean is confined to its prescribed boundaries, and the inhabitants of the earth are retained to its surface, and prevented from flying upward through the voids of space. In like manner, the law by which light is refracted produces a variety of beneficial effects essential to the present constitution of our world and the comfort of its inhabit-

ants. When a ray of light enters obliquely into the atmosphere, instead of passing directly through it bends a little downward, so that the greater portion of the rays which thus enter the atmospheric mass descend by inflection to the earth. We then enjoy the benefits of that light which would otherwise have been totally lost. We perceive the light of day an hour before the solar orb makes its appearance, and a portion of its light is still retained when it has descended nearly eighteen degrees below our horizon. We thus enjoy, throughout the year, seven hundred and thirty hours of light which would have been lost had it not been refracted down upon us from the upper regions of the atmosphere. To the inhabitants of the polar regions this effect is still more interesting and beneficial. Were it not for their twilight, they would be involved, for a much longer period than they now are, in perpetual darkness; but by the powerful refraction of light which takes place in the frigid zones, the day sooner makes its appearance toward spring, and their long winter nights are, in certain cases, shortened by the period of thirty days. Under the poles, where the darkness of night would continue six months without intermission, if there were no refraction, total darkness does not prevail during the one-half of this period. When the sun sets, at the north pole, about the 23d of September, the inhabitants (if any) enjoy a perpetual aurora until he has descended eighteen degrees below the horizon. In his course through the ecliptic the sun is two months before he can reach this point, during which time there is a perpetual twilight. In two months more he arrives again at the same point, namely, eighteen degrees below the horizon, when a new twilight commences, which is continually increasing in brilliancy for other two months, at the end of which the body of this luminary is seen rising in all its glory. So that, in this region, the light of day is enjoyed in a greater or less degree, for ten months without interruption by the effects of atmospheric refraction; and, during the two months when the influence of the solar light is entirely withdrawn, the moon is shining above the horizon for two half months without intermission; and thus it happens that no mere than two separate fortnights are passed in absolute darkness; and this darkness is alleviated by the light of the stars and the frequent coruscations of the Aurora Borealis. Hence it appears that there are no portions of our globe that enjoy, throughout the year, so large a portion of the solar light as these northern regions, which is chiefly owing to the refraction of the atmosphere.

The refraction of light by the atmosphere, combined with its power of reflecting it, is likewise the cause of that universal light and splendor which appears on all the objects around us. Were the earth disrobed of its atmosphere, and exposed naked to the solar beams, in this case we might see the sun without having day, strictly so called. His rising would not be preceded by any twilight as it now is. The most intense darkness would cover us until the very moment of his rising; he would then suddenly break out from under the horizon with the same splendor he would exhibit at the highest part of his course, and would not change his brightness until the very moment of his setting, when, in an instant, all would be black as the darkest night. At noonday we should see the sun like an intensely-brilliant globe shining in a sky as black as ebony, like a clear fire in the night seen in the midst of an extensive field, and his rays would show us the adjacent objects

immediately around us: but the rays which fall on the objects remote from us would be forever lost in the expanse of the heavens. Instead of the beautiful azure of the sky, and the colors which distinguish the face of nature by day, we should see nothing but an abyss of darkness, and the stars shining from a vault as dark as chaos. Thus there would be no day, such as we now enjoy, without the atmosphere: since it is by the refraction and reflections connected with this aerial fluid that light is so modified and directed as to produce all that beauty, splendor, and harmony which appear on the concave of the sky, and on the objects which diversify our terrestrial abode.

The effect of refraction, in respect to *terrestrial* objects, is likewise of a beneficial nature. The quantity of this refraction is estimated by Dr. Maskelyne at one-tenth of the distance of the object observed, expressed in degrees of a great circle. Hence, if the distance be 10,000 fathoms, its tenth part 1000 fathoms, is the sixtieth part of a degree, or one minute, which is the refraction in altitude; Le Gendre estimates it at one-fourteenth, De Lambre at one-eleventh, and others at a twelfth of the distance; but it must be supposed to vary at different times and places according to the varying state of the atmosphere. This refraction, as it makes objects appear to be raised higher than they really are, enlarges the extent of our landscapes, and enables us to perceive distant objects which would otherwise have been invisible. It is particularly useful to the navigator at sea. It is one important object of the mariner, when traversing his course, to look out for capes and headlands, rocks and islands, so as to descry them

as soon as they are within the reach of his eye. Now, by means of refraction, the tops of hills and the elevated parts of coasts are apparently raised into the air, so that they may be discovered several leagues farther off on the sea than they would be did no such refractive power exist. This circumstance is therefore a considerable benefit to the science of navigation, in enabling the mariner to steer his course aright, and to give him the most early warning of the track he ought to take, or of the dangers to which he may be exposed.

In short, the effects produced by the refraction and reflection of light on the scenery connected with our globe teach us that these principles, in the hand of the Almighty, might be so modified and directed as to produce the most picturesque, the most glorious, and wonderful phenomena, such as mortal eyes have never yet seen, and of which human imagination can form no conception; and in other worlds, more resplendent and magnificent than ours, such scenes may be fully realized, in combination with the operation of physical principles and agents with which we are at present unacquainted. From what we already know of the effects of the reflection and the refraction of light, it is not beyond the bounds of probability to suppose that, in certain regions of the universe, light may be reflected and refracted through different mediums, in such a manner as to present to the view of their inhabitants the prominent scenes connected with distant systems and worlds, and to an extent as shall infinitely surpass the effects produced by our most powerful telescopes.

## CHAPTER III.

### ON THE REFRACTION OF LIGHT THROUGH SPHERICAL TRANSPARENT SUBSTANCES, OR LENSES.

It is to the refraction of light that we are indebted for the use of lenses or artificial glasses to aid the powers of the vision. It lays the foundation of telescopes, microscopes, camera obscuras, phantasmagorias, and other optical instruments, by which so many beautiful, useful, and wonderful effects have been produced. In order, therefore, to

abstract mathematical demonstrations, but shall simply offer a few explanations of general principles, and several experimental illustrations, which may enable the general reader to understand the construction of the optical instruments to be afterward described.

A lens is a transparent substance of a different density from the surrounding medium, and terminating in two surfaces, either both spherical, or one spherical and the other plain. It is usually made of glass, but may also be formed of any other transparent substance, as ice, crystal, diamonds, pebbles, or fluids of different densities and refractive powers, inclosed between concave glasses. Lenses are ground into various forms, according to the purpose they are intended to serve. They may be generally distinguished as being either *convex* or *concave*. A convex glass is thickest in the middle, and thinner toward the extremities. Of these there are various forms, which are represented in fig. 5. *A* is a *plano-convex* lens, which has one side plane, and the other spherical or convex. *B* is a *plano-concave*, which is plane on the one side and concave on the other. *C* is a *double-convex*, or one which is spherical on both sides. *D*, a *double-concave*, or concave on both sides. *E* is called a *meniscus*, which is convex on one side and concave on the other. *F* is a *concavo-convex*, the convex side of which is of a

Fig. 5.

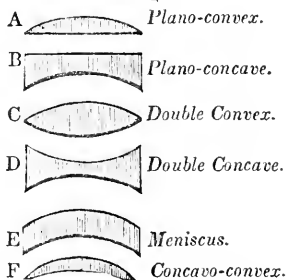

illustrate the principles on which such instruments are constructed, it is necessary to explain the manner in which the rays of light are refracted and modified when passing through spherical mediums of different forms. I do not intend, however, to enter into the minutiae of this subject, nor into any

smaller sphere than the concave. In regard to the degree of convexity or concavity in lenses, it is evident that there may be almost an infinite variety. For every convex surface is to be considered as the segment of a circle, the diameter and the radius of which may vary to almost any extent. Hence lenses have been formed by opticians, varying from one fiftieth of an inch in radius to two hundred feet. When we speak of the length of the radius of a lens, as, for instance when we say that a lens is two inches or forty inches radius, we mean that the convex surface of the glass is the part of a circle, the radius of which, or half the diameter, is two inches or forty inches; or, in other words, were the portion of the sphere on which it is ground formed into a globe of corresponding convexity, it would be four inches or eighty inches in diameter.

The axis of a lens is a straight line drawn through the center of its spherical surface; and, as the spherical sides of every lens are arches of circles, the axis of the lens would pass through the center of that circle of which its sides are segments. Rays are those emanations of light which proceed from a luminous body, or from a body that is illuminated. The Radiant is that body or object which emits the rays of light, whether it be a self-luminous body, or one that only reflects the rays of light. Rays may proceed from a Radiant in different directions. They may be either parallel, converging, or diverging. Parallel rays are those which proceed equally distant from each other through their whole course. Rays proceeding from the sun, the planets, the stars, and distant terrestrial objects are considered as parallel, as in fig. 6. Converging rays are such as, proceeding from a body, approach nearer and nearer in their progress, tending to a certain point where they all unite. Thus the rays proceeding from the object *AB* (fig. 7) to the point *F*, are said to converge toward that point. All convex glasses cause parallel rays which fall upon them to converge in a greater or less degree; and they render converging rays still more convergent. If *AB*, fig. 7, represent a convex lens, and *HGI* parallel rays falling upon it, they will be refracted, and converge toward the point *F*, which is called the focus or burning point; because when the sun's rays are thus converged to a point by a large lens, they set on fire combustible substances. In this point the rays meet and intersect each other. Diverging rays are those which, proceeding from any point, as *A*, fig. 8, continually recede from each other as they pass along in their course toward *B* *C*. All the rays which proceed from near objects, as a window in a room, or an adjacent house or garden, are more or less divergent. The following figures show the effects of parallel, converging, and diverging rays, in passing through a double convex lens:

Fig. 9 shows the effects of parallel rays, *KA*, *DELB*, falling on a convex glass, *AB*. The rays which fall near the extremities at *A* and *B* are bent or refracted toward *CF*, the focus, and center of convexity. It will be observed that they are less refracted as they approach the center of the lens, and the central ray *DEC*, which is called the axis of the lens, and which passes through its center, suffers no refraction. Fig. 10 exhibits the course of converging rays when passing through a similar lens. In this case the rays converge to a focus nearer to the lens than the center; for a convex lens uniformly increases the convergence of converging rays. The converging rays here represented may be conceived as having been refracted by another convex lens of a longer

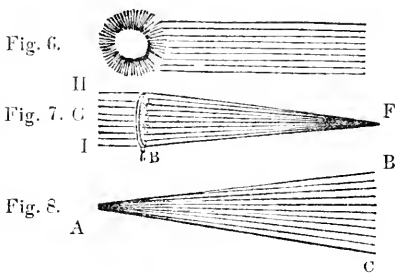

focus, and passing on toward a point of convergence, were intercepted by the lens *AB*. The point *D* is the place where the rays would have converged to a focus, had they not been thus intercepted. Fig. 11 represents the course of diverging rays when falling on a double convex glass. In this case, the rays *DB*, *DA*, &c., after passing through the lens, converge to a focus at a point considerably farther from the lens than its center, as at *F*. Such rays must be considered as

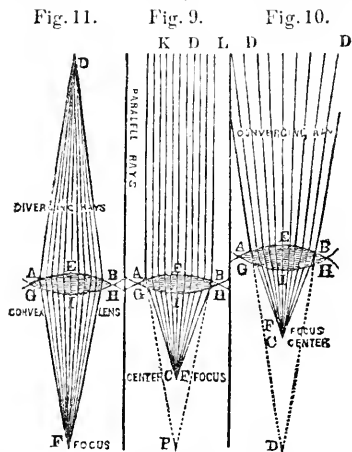

proceeding from near objects, and the fact may be illustrated by the following experiment: Take a common reading glass, and hold it in the rays of the sun, opposite a sheet of writing paper or a white wall, and observe at what distance from the glass the rays on the paper converge to a small, distinct white spot. This distance gives the focal length of the lens by parallel rays. If now we hold the glass within a few feet of a window, or a burning candle, and receive its image on the paper, the focal distance of the image from the glass will be found to be longer. If, in the former case, the focal distance was twelve inches, in the latter case it will be thirteen, fifteen, or sixteen inches, according to the distance of the window or the candle from the glass.

If the lens *AB*, fig. 9, on which parallel rays are represented as falling, were a *plano-convex*, as represented at *A*, fig. 5, the rays would converge to a point *P*, at double the radius, or the whole diameter of the sphere of which it is a segment. If the thickness, of a plano convex be considered, and if it be exposed on its convex side to parallel rays as those of the sun, the focus will be at the distance of twice the radius, wanting two-thirds of the thickness of the lens. But if the same lens be exposed with its plane side to parallel rays, the focus will then be precisely at the distance of twice the radius from the glass.

The effects of *concave* lenses are directly opposite to those of *convex*. Parallel rays, striking one of those glasses, instead of converging toward a point, are made to *diverge*. Rays already divergent are rendered more so, and convergent rays are made less convergent. Hence objects seen through concave glasses appear considerably smaller and more distant than they really are. The following diagram, fig. 12, represents the course of parallel rays through a double concave lens, where the parallel rays *T A, D E, I B, &c.* when passing through the concave glass *A B*, diverge into the rays *G L, E C, H P, &c.*, as if they proceeded from *F*, a point before the lens, which is the principal focus of the lens :

Fig. 12.

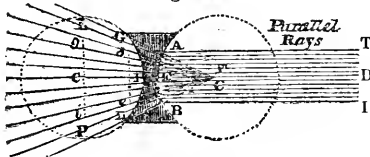

The principal focal distance, *E F*, is the same as in convex lenses. Concave glasses are used to correct the imperfect vision of short-sighted persons. As the form of the eye of such persons is too convex, the rays are made to converge before they reach the optic nerve; and therefore a concave glass, causing a little divergency, assists this defect of vision, by diminishing the effect produced by the too great convexity of the eye, and lengthening its focus. These glasses are seldom used, in modern times, in the construction of optical instruments, except as eye-glasses for small pocket perspectives, and opera-glasses.

To find the focal distance of a concave glass.—Take a piece of pasteboard or card paper, and cut a round hole in it, not larger than the diameter of the lens; and on another piece of pasteboard describe a circle whose diameter is just double the diameter of the hole. Then apply the piece with the hole in it to the lens, and hold them in the sunbeams, with the other piece at such a distance behind that the light proceeding from the hole may spread or diverge so as precisely to fill the circle; then the distance of the circle from the lens is equal to its virtual focus, or to its radius, if it be a double concave, and to its diameter, if a plano-concave. Let *d, e* (fig. 12) represent the diameter of the hole, and *a, i*, the diameter of the circle, then the distance *C, I*, is the virtual focus of the lens.\*

The *meniscus*, represented at *E*, fig. 5, is like the crystal of a common watch, and, as the convexity is the same as the concavity, it neither magnifies nor diminishes. Sometimes, however, it is made in the form of a crescent, as at *F*, fig. 5, and is called a *concavo-convex* lens; and, when the convexity is greater than the concavity, or when it is thickest in the middle, it acts nearly in the same way as a double or plano-convex lens of the same focal distance.

#### OF THE IMAGES FORMED BY CONVEX LENSES.

It is a remarkable circumstance, and which would naturally excite admiration, were it not so

\* This mode of finding the focus of a concave lens may be varied as follows: Let the lens be covered with paper, having two small circular holes; and, on the paper for receiving the light, describe also two small circles, but with their centers at twice the distance from each other of the centers of the circles. Then move the paper to and from, until the middle of the sun's light, coming through the holes, falls exactly on the middle of the circles; that distance of the paper from the lens will be the focal length required.

common and well known, that *when the rays of light from any object are refracted through a convex lens, they paint a distinct and accurate picture of the object before it, in all its colors, shades, and proportions*. Previous to experience, we could have had no conception that light, when passing through such substances, and converging to a point, could have produced so admirable an effect—an effect on which the construction and utility of all our optical instruments depend. The following figure will illustrate this position :

Fig. 13.

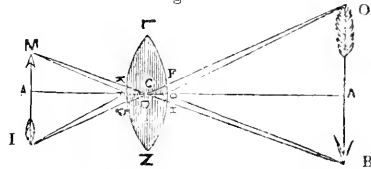

Let *L N* represent a double convex lens, *A, C, a* its axis, and *O B* an object perpendicular to it. A ray passing from the extremity of the object at *O*, after being refracted by the lens at *F*, will pass on in the direction *F I*, and form an image of that part of the object at *I*. This ray will be the axis of all the rays which fall on the lens from the point *O*, and *I* will be the focus where they will all be collected. In like manner, *B C M* is the axis of that parcel of rays which proceed from the extremity of the object *B*, and their focus will be at *M*; and since all the points in the object between *O* and *B* must necessarily have their foci between *I* and *M* a complete picture of the points from which they come will be depicted, and consequently an image of the whole object *O B*.

It is obvious, from the figure, that the image of the object is formed in the focus of the lens in an *inverted position*. It must necessarily be in this position, as the rays cross at *C*, the center of the lens; and as it is impossible that the rays from the upper part of the object, *O*, can be carried by refraction to the upper end of the image at *M*. This is a universal principle in relation to convex lenses of every description, and requires to be attended to in the construction and use of all kinds of telescopes and microscopes. It is easily illustrated by experiment. Take a convex lens of eight, twelve, or fifteen inches focal distance, such as a reading glass, or the glass belonging to a pair of spectacles, and holding it, at its focal distance from a white wall, in a line with a burning candle, the flame of the candle will be seen depicted on the wall in an inverted position, or turned upside down. The same experiment may be performed with a window-sash, or any other bright object. But the most beautiful exhibition of the images of objects formed by convex lenses is made by darkening a room, and placing a convex lens of a long focal distance, in a hole cut out of the window-shutter; when a beautiful inverted landscape or picture of all the objects before the window, will be painted on a white paper or screen placed in the focus of the glass. The image thus formed exhibits not only the proportions and colors, but also the motions of all the objects opposite the lens, forming, as it were, a living landscape. This property of lenses lays the foundation of the camera obscura, an instrument to be afterward described.

The following principles in relation to images formed by convex lenses, may be stated: 1. That *the image subtends the same angle at the center of*

the glass as the object itself does. Were an eye placed at *C*, the center of the lens *LN*, fig. 13, it would see the object *OB* and the image *IM* under the same optical angle, or, in other words, they would appear equally large; for, whenever right lines intersect each other, as *OI* and *BM*, the opposite angles are always equal, that is, the angle *MCI* is equal to the angle *OCB*. 2. The length of the image formed by a convex lens is, to the length of the object, as the distance of the image is to the distance of the object from the lens; that is, *MI* is to *OB*: as *CA* to *CA*. Suppose the distance of the object *CA* from the lens to be forty-eight inches, the length of the object *OB* = sixteen inches, and the distance of the image from the lens six inches, then the length of the image will be found by the following proportion, 48 : 16 : : 6 : 2, that is, the length of the image, in such a case, is two inches. 3. If the object be at an infinite distance, the image will be formed exactly in the focus. 4. If the object be at the same distance from the lens as its focus, the image is removed to an infinite distance on the opposite side; in other words, the rays will proceed in a parallel direction. On this principle, lamps on the streets are sometimes directed to throw a bright light along a footpath where it is wanted, when a large convex glass is placed at its focal distance from the burner; and on the same principle, light is thrown to a great distance from lighthouses, either by a very large convex lens of a short focal distance, or by a concave reflector. 5. If the object be at double the distance of the focus from the glass, the image will also be at double the distance of the focus from the glass. Thus, if a lens of six inches focal distance be held at twelve inches' distance from a candle, the image of the candle will be formed at twelve inches from the glass on the other side. 6. If the object be a little farther from the lens than its focal distance, an image will be formed at a distance from the object, which will be greater or smaller in proportion to the distance. For example, if a lens five inches focus be held at a little more than five inches from a candle, and a wall or screen at five feet six inches' distance receive the image, a large and inverted image of the candle will be depicted, which will be magnified in proportion as the distance of the wall from the candle exceeds the distance of the lens from the candle. Suppose the distance of the lens to be five and a half inches, then the distance of the wall where the image is formed, being twelve times greater, the image of the candle will be magnified twelve times. If *MI* (fig. 13) be considered as the object, then *OB* will represent the magnified image on the wall. On this principle, the image of the object is formed by the small object-glass of a compound microscope. On the same principle, the large pictures are formed by the Magic Lantern and the Phantasmagoria; and in the same way small objects are represented in a magnified form on a sheet or wall by the Solar microscope. 7. All convex lenses magnify the objects seen through them, in a greater or less degree. The shorter the focal distance of the lens, the greater is the magnifying power. A lens four inches focal distance will magnify objects placed in the focus two times in length and breadth; a lens two inches focus will magnify four times; a lens one inch focus, eight times; a lens half an inch focus, sixteen times, &c., supposing eight inches to be the least distance at which we see near objects distinctly. In viewing objects with small lenses, the object to be magnified should be placed exactly at the focal distance of the lens, and the eye at about the same distance on the other side of the lens. When we speak of mag-

nifying power, as, for example, that a lens one inch focal distance magnifies objects eight times, it is to be understood of the lineal dimensions of the object. But as every object at which we look has breadth as well as length, the surface of the object is in reality magnified sixty-four times, or the square of its lineal dimensions; and for the same reason a lens half an inch focal distance magnifies the surfaces of objects 256 times.

REFLECTIONS DEDUCED FROM THE PRECEDING SUBJECT.

Such are some of the leading principles which require to be recognized in the construction of refracting telescopes, microscopes, and other dioptric instruments whose performance chiefly depends on the refraction of light. It is worthy of particular notice, that all the phenomena of optical lenses now described depend upon that peculiar property which the Creator has impressed upon the rays of light, that, when they are refracted to a focus by a convex transparent substance, they depict an accurate image of the objects whence they proceed. This, however common, and however much overlooked by the bulk of mankind, is, indeed, a very wonderful property with which light has been indued. Previous to experience, we could have had no conception that such an effect would be produced; and, in the first instance, we could not possibly have traced it to all its consequences. All the objects in creation might have been illuminated as they now are, for aught we know, without sending forth either direct or reflected rays with the property of forming exact representations of the objects whence they proceed. But this we find to be a universal law in regard to light of every description, whether as emanating directly from the sun, or as reflected from the objects he illuminates, or as proceeding from bodies artificially enlightened. It is a law or a property of light not only in our own system, but throughout all the systems of the universe to which mortal eyes have yet penetrated. The rays from the most distant star which astronomers have described are indued with this property, otherwise they could never have been perceived by means of our optical instruments; for it is by the pictures or images formed in these instruments that such distant objects are brought to view. Without this property of light, therefore, we should have had no telescopes, and, consequently, we could not have surveyed, as we can now do, the hills and vales, the deep caverns, the extensive plains, the circular ranges of mountains, and many other novel scenes which diversify the surface of our moon. We should have known nothing of the stupendous spots which appear on the surface of the sun—of the phases of Venus—of the satellites and belts of Jupiter—of the majestic rings of Saturn—of the existence of Uranus and his six moons, or of the planets Vesta, Juno, Ceres, and Pallas, nor could the exact bulks of any of these bodies have been accurately determined. But, above all, we should have been entirely ignorant of the wonderful phenomena of double stars—which demonstrate that suns revolve around suns—of the thousands and millions of stars which crowd the profundities of the Milky Way and other regions of the heavens—of the thousands of nebulae or starry systems which are dispersed throughout the immensity of the firmament, and many other objects of sublimity and grandeur, which fill the contemplative mind with admiration and awe, and raise its faculties to higher conceptions than it could otherwise have formed of the om-

nipotence and grandeur of the Almighty Creator.

Without this property of the rays of light, we should, likewise, have wanted the use of the microscope, an instrument which has disclosed a world invisible to common eyes, and has opened to our view the most astonishing exhibitions of Divine mechanism, and of the wisdom and intelligence of the Eternal Mind. We should have been ignorant of those tribes of living beings, invisible to the unassisted eye, which are found in water, vinegar, and many other fluids, many of which are twenty thousand times smaller than the least visible point, and yet display the same admirable skill and contrivance in their construction as are manifested in the formation of the larger animals. We should never have beheld the purple tide of life, and even the globules of the blood rolling with swiftness through veins and arteries smaller than the finest hair; or had the least conception that numberless species of animated beings, so minute that a million of them are less than a grain of sand, could have been rendered visible to human eyes, or that such a number of vessels, fluids, movements, diversified organs of sensation, and such a profusion of the richest ornaments and the gayest colors could have been concentrated in a single point. We should never have conceived that even the atmosphere is replenished with invisible animation, that the waters abound with countless myriads of sensitive existence, that the whole earth is full of life, and that there is scarcely a tree, plant, or flower but affords food and shelter to a species of inhabitants peculiar to itself, which enjoy the pleasures of existence and share in the bounty of the Creator. We could have formed no conception of the beauties and the varieties of mechanism which are displayed in the scenery of that invisible world to which the microscope introduces us—beauties and varieties, in point of ornament and delicate contrivance, which even surpass what is beheld in the visible operations and aspect of nature around us. We find joints, muscles, a heart, stomach, entrails, veins, arteries, a variety of motions, a diversity of forms, and a multiplicity of parts and functions in breathing atoms. We behold in a small fiber of a peacock's feather, not more than one-eighth of an inch in length, a profusion of beauties no less admirable than is presented by the whole feather to the naked eye, a stem sending out multitudes of lateral branches, each of which emits numbers of little sprigs, which consist of a multitude of bright shining globular parts, adorned with a rich variety of colors. In the sections of plants, we see thousands and ten thousands of tubes and pores, and other vessels for the conveyance of air and juices for the sustenance of the plant; in some instances, more than ten hundred thousand of these being compressed within the space of a quarter of an inch in diameter, and presenting to the eye the most beautiful configurations. There is not a weed,

nor a moss, nor the most insignificant vegetable, which does not show a multiplicity of vessels disposed in the most curious manner for the circulation of sap for its nourishment, and which is not adorned with innumerable graces for its embellishment. All these and ten thousands of other wonders which lie beyond the limits of natural vision, in this new and unexplored region of the universe, would have been forever concealed from our view had not the Creator indued the rays of light with the power of depicting the images of objects, when refracted by convex transparent substances.

In this instance, as well as in many others, we behold a specimen of the admirable and diversified effects which the Creator can produce from the agency of a single principle in nature. By means of optical instruments, we are now enabled to take a more minute and expansive view of the amazing operations of nature, both in heaven and on earth, than former generations could have surmised. These views tend to raise our conceptions of the attributes of that Almighty Being who presides over all the arrangements of the material system, and to present them to our contemplation in a new, a more elevated, and expansive point of view. There is, therefore, a connection which may be traced between the apparently accidental principle of the rays of light forming images of objects and the comprehensive views we are now enabled to take of the character and perfections of the Divinity. Without the existence of the law or principle alluded to, we could not, in the present state, have formed precisely the same conceptions either of the Omnipotence, or of the wisdom and intelligence of the Almighty. Had no microscope ever been invented, the idea never could have entered into the mind of man that worlds of living beings exist beyond the range of natural vision, that organized beings, possessed of animation, exist, whose whole bulk is less than the ten hundred thousandth part of the smallest grain of sand; that, descending from a visible point to thousands of degrees beyond it, an invisible world exists, peopled with tribes of every form and size, the extent of which, and how far it verges toward infinity downward, mortals have never yet explored, and perhaps will never be able to comprehend. This circumstance alone presents before us the perfections of the Divinity in a new aspect, and plainly intimates that it is the will and the intention of the Deity that we should explore his works, and investigate the laws by which the material world is regulated, that we may acquire more expansive views of his character and operations. The inventions of man, in relation to art and science, are not, therefore, to be considered as mere accidental occurrences, but as special arrangements in the Divine government, for the purpose of carrying forward the human mind to more clear and ample views of the scenes of the universe, and of the attributes and the agency of Him "who is wonderful in counsel and excellent in working."

## CHAPTER IV.

### ON THE REFLECTION OF LIGHT.

The reflection of the rays of light is that property by which, after approaching the surfaces of bodies, they are thrown back, or repelled. It is in consequence of this property that all the objects around us, and all the diversified landscapes on our globe are rendered visible. It is by light reflected from their surfaces that we perceive the planetary bodies and their satellites, the belts of Jupiter, the rings of Saturn, the various objects which diversify the surface of the Moon, and all the bodies in the universe which have no light of their own. When the rays of light fall upon rough and uneven surfaces, they are reflected very irregularly, and scattered in all directions, in consequence of which thousands of eyes, at the same time, may perceive the same objects, in all their peculiar colors, aspects and relations. But when they fall upon certain smooth and polished surfaces, they are reflected with regularity, and according to certain laws. Such surfaces, when highly polished, are called *Mirrors* or *Speculums*; and it is to the reflection of light from such surfaces, and the effects it produces, that I am now to direct the attention of the reader.

Mirrors, or specula, may be distinguished into three kinds, *plane*, *concave*, and *convex*, according as they are bounded by plane or spherical surfaces. These are made either of *metal* or of *glass*, and have their surfaces highly polished for the purpose of reflecting the greatest number of rays. Those made of glass are foliated or quicksilvered on one side; and the metallic specula are generally formed of a composition of different metallic substances, which, when accurately polished, is found to reflect the greatest quantity of light.—I shall, in the first place, illustrate the phenomena of reflection produced by *plane mirrors*.

When light impinges, or falls, upon a polished flat surface, rather more than the half of it is reflected, or thrown back in a direction similar to that of its approach; that is to say, if it fall *perpendicularly* on the polished surface, it will be perpendicularly reflected, but if it fall *obliquely*, it will be reflected with the same obliquity. Hence, the following fundamental law regarding the reflection of light has been deduced both from experiment and mathematical demonstration, namely, that *the angle of reflection is, in all cases, exactly equal to the angle of incidence*. This is a law which is universal in all cases of reflection, whether it be from plane or spherical surfaces, or whether these surfaces be concave or convex, and which requires to be recognized in the construction of all instruments which depend on the reflection of the rays of light. The following figure (fig. 14) will illustrate the position now stated:

Let *AB* represent a plane mirror, and *CD* a line or ray of light perpendicular to it. Let *FD* represent the *incident ray* from any object, then *DE* will be the reflected ray, thrown back in the direction from *D* to *E*, and it will make, with the perpendicular *CD*, the same angle which the incident ray *FD* did with the same perpendicular; that is, the angle *FDC* will be equal to the angle *EDC*, in all cases of obliquity.

The incident ray of light may be considered as rebounding from the mirror, like a tennis ball from a marble pavement, or the wall of a court.

Fig. 14.

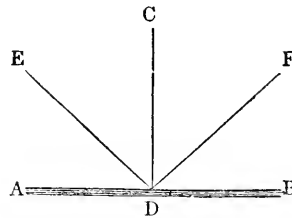

In viewing objects by reflection, we see them in a different direction from that in which they really are, namely, along the line in which the rays come to us last. Thus, if *AB* (fig. 15) represent a plane mirror, the image of an object, *C*, appears to the eye at *E*, behind the mirror, in the direction *EG*, and always in the intersection

Fig. 15.

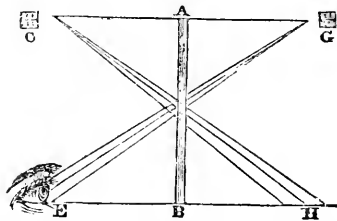

*G* of the perpendicular *CG*, and the reflected ray *EG*; and, consequently, at *G* as far behind the mirror as the object *C* is before it. We therefore see the image in the line *EG*, the direction in which the reflected rays proceed. A plane mirror does not alter the figure or size of objects; but the whole image is equal and similar to the whole object, and has a like situation with respect to one side of the plane, that the object has with respect to the other.

Mr. Walker illustrates the manner in which we see our faces in a mirror by the following figure (16) *AB* represents a mirror, and *o* a person looking into it. If we conceive a ray proceeding from the forehead *c* *E*, it will be sent to the eye at *o*, agreeably to the angle of incidence and reflection. But the mind puts *c* *E* *o* into one line, and the forehead is seen at *h*, as if the lines *c* *E* *o* had turned on a hinge at *E*. It seems a wonderful faculty of the mind to put the two oblique lines *c* *E* and *o* *E* into one straight line *o* *h*, yet it is seen every time we look at a mirror. For the ray has really travelled from *c* to *E*, and from *E* to *o*, and it is that journey which determines the distance of the object; and hence we see ourselves as far beyond the mirror as we stand from it.—Though a ray is here taken only from one part of the face, it may be easily conceived that rays

from every part of the face must produce a similar effect.

In every plane mirror the image is always equal to the object, at what distance soever it may

Fig. 16.

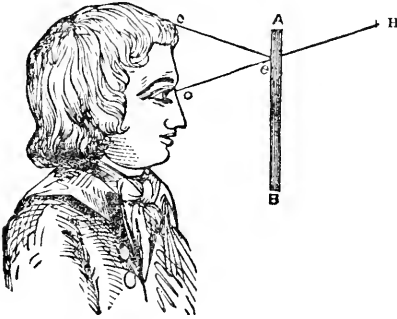

be placed; and, as the mirror is only at half the distance of the image from the eye, it will completely receive an image of *twice* its own length. Hence, a man six feet high may view himself completely in a looking-glass of three feet in length and half his own breadth; and this will be the case at whatever distance he may stand from the glass. Thus, the man *A C* (fig. 17) will see

Fig. 17.

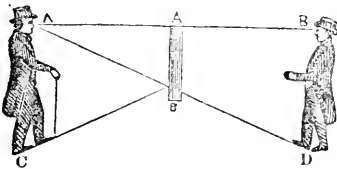

the whole of his own image in the glass *A B*, which is but one half as large as himself. The rays from the head pass to the mirror in the line *A A*, perpendicular to the mirror, and are returned to the eye in the same line; consequently, having traveled twice the length *A A*, the man must see his head at *B*. From his feet, *C*, rays will be sent to the bottom of the mirror, at *B*; these will be reflected at an equal angle to the eye in the direction *B A*, as if they had proceeded in the direction *D B A*, so that the man will see his foot at *D*, and, consequently, his whole figure at *B D*.

A person, when looking into a mirror, will always see his own image as far beyond the mirror as he is before it; and as he moves to or from it, the image will, at the same time move toward or from him on the other side, but apparently with a double velocity, because the two motions are equal and contrary. In like manner, if, while the spectator is at rest, an object be in motion, its image behind the mirror will be seen to move at the same time. And if the spectator moves, the images of objects that are at rest will appear to approach or recede from him, after the same manner as when he moves toward real objects; plane mirrors reflecting not only the object, but the distance also, and that exactly in its natural dimensions. The following principle is sufficient for explaining most of the phenomena seen in a plane mirror, namely: *That the image of an object seen in a plane mirror is always in a perpendicular*

*to the mirror joining the object and the image, and that the image is as much on one side the mirror as the object is on the other.*

## REFLECTION BY CONVEX AND CONCAVE MIRRORS.

Both convex and concave mirrors are formed of portions of a sphere. A convex speculum is ground and polished in a *concave* dish or tool which is a portion of a sphere, and a concave speculum is ground upon a convex tool. The inner surface of a sphere brings parallel rays to a focus at *one-fourth* of its diameter, as represented in the following figure, where *C* is the center of the sphere on which the concave speculum *A B* is formed, and *F* the focus where parallel rays from a distant object would be united after reflection, that is, at one-half the radius, or one-fourth

Fig. 18.

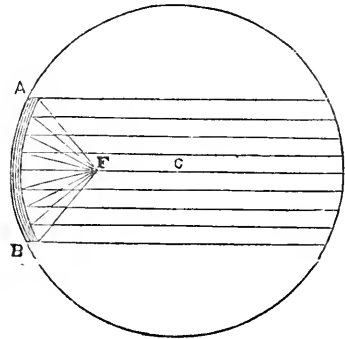

of the diameter from the surface of the speculum. Were a speculum of this kind presented to the sun, *F* would be the point where the reflected rays would be converged to a focus, and set fire to combustible substances if the speculum be of a large diameter, and of a short focal distance.—Were a candle placed in that focus, its light would be reflected parallel, as represented in the figure. These are properties of concave specula which require to be particularly attended to in the construction of reflecting telescopes. It follows, from what has been now stated, that if we intend to form a speculum of a certain focal distance, for example, two feet, it is necessary that it *should be ground upon a tool whose radius is double that distance, or four feet.*

## PROPERTIES OF CONVEX MIRRORS.

From a convex surface, parallel rays, when reflected, are made to diverge: convergent rays are reflected less convergent; and divergent rays are rendered more divergent. It is the nature of all convex mirrors and surfaces to scatter or *disperse* the rays of light, and in every instance to impede their convergence. The following figure shows the course of parallel rays as reflected from a convex mirror. *A E B* is the convex surface of the mirror, and *K A, I E, L B* parallel rays falling upon it. These rays, when they strike the mirror, are made to diverge in the direction *A G, B H*, &c., and both the parallel and divergent rays are here represented as they appear in a dark chamber when a convex mirror is presented to the solar rays. The dotted lines denote only the course or tendency of the reflected rays toward the *virtual* focus *F*, were they not intercepted by the mirror



This virtual focus is just equal to half the radius *CE*.

The following are some of the properties of convex mirrors: 1. The image appears always erect, and behind the reflecting surface. 2. The image is smaller than the object, and the diminution is greater in proportion as the object is farther from the mirror; but if the object touch the mir-

Fig. 19.

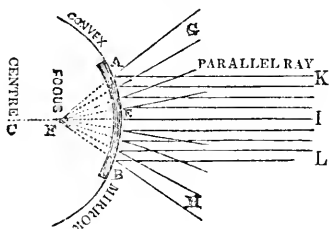

ror, the image at the point of contact is of the same size as the object. 3. The image does not appear so far behind the reflecting surface as in a plane mirror. 4. The image of a straight object, placed either parallel or oblique to the mirror, is seen *curved* in the mirror, because the different points of the object are not all at an equal distance from the surface of the mirror. 5. Concave mirrors have a *real* focus where an image is actually formed; but convex specula have only a *virtual* focus, and this focus is behind the mirror, no image of any object being formed before it.

The following are some of the purposes to which convex mirrors are applied: They are frequently employed by painters for reducing the proportions of the objects they wish to represent, as the images of objects diminish in proportion to the smallness of the radius of convexity, and to the distances of objects from the surface of the mirror. They form a fashionable part of modern furniture, as they exhibit a large company assembled in a room, with all the furniture it contains, in a very small compass, so that a large hall, with all its objects, and even an extensive landscape, being reduced in size, may be seen from one point of view. They are likewise used as the small specula of those reflecting telescopes which are fitted up on the *Cassegrainian* plan, and in the construction of Smith's Reflecting Microscope. But, on the whole, they are very little used in the construction of optical instruments.

PROPERTIES OF CONCAVE SPECULUMS.

Concave specula have properties very different from those which are convex; they are of more importance in the construction of reflecting telescopes and other optical instruments, and therefore require more minute description and illustration. Concave mirrors cause parallel rays to converge; they increase the convergence of rays that are already converging; they diminish the divergence of diverging rays, and in some cases render them parallel, and even convergent; which effects are all in proportion to the concavity of the mirror. The following figures show the course of diverging and parallel rays as reflected from concave mirrors.

Fig. 20 represents the course of *parallel* rays, and *AB* the concave mirror on which they fall. In this case they are reflected so as to unite at *F*, which point is distant from its surface *one-fourth* of the diameter of the sphere of the mirror. This point is called the focus of parallel rays, or the

*true focus of the mirror*; and, since the subbeams are parallel among themselves, if they are received on a concave mirror, they will be reflected to that point, and there burn in proportion to the quantity

Fig. 20.

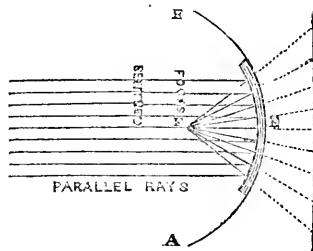

of rays collected by the mirror. Fig. 21 shows the direction of *diverging* rays, or those which proceed from a near object. These rays proceeding from an object farther from the mirror than the true focal point, as from *D* to *A* and to *B*, are

Fig. 21.

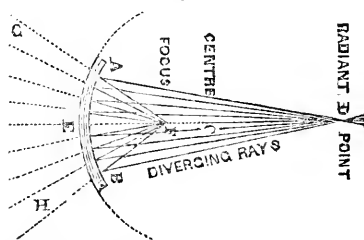

reflected converging, and meet at a point *F*, farther from the mirror than the focal point of parallel rays. If the distance of the radiant, or object *D*, be equal to the radius *CE*, then will the focal distance be likewise equal to the radius; that is, if an object be placed in the center of a concave speculum, the image will be reflected upon the object, or they will seem to meet and embrace each other in the center. If the distance of the radiant be equal to half the radius, its image will be reflected to an infinite distance, for the rays will then be parallel. If, therefore, a luminous body be placed at half the radius from a concave speculum, it will enlighten places directly before it at great distances. Hence their use when placed behind a candle in a common lantern; hence their utility in throwing light upon objects in the Magic Lantern and Phantasmagoria; and hence the vast importance of very large mirrors of this description, as now used in most of our lighthouses, for throwing a brilliant light to great distances at sea, to guide the mariner when directing his course under the cloud of night.

When *converging* rays fall upon a concave mirror, they are reflected more converging, and unite at a point between the focus of parallel rays and the mirror; that is, nearer the mirror than one-half the radius; and their precise degree of convergence will be greater than that wherein they converged before reflection.

OF THE IMAGES FORMED BY CONCAVE MIRRORS.

If rays proceeding from a distant object fall upon a concave speculum, they will paint an image or representation of the object on its focus *before* the mirror. This image will be inverted, because

the rays cross at the points where the image is formed. We have already seen that a convex glass forms an image of an object *behind* it; the rays of light from objects *pass through* the glass, and the picture is formed on the side farthest from the object. But in concave mirrors the images of distant objects—and of all objects that are farther from its surface than its principal focus—are formed *before* the mirror, or on the same side as the object. In almost every other respect, however, the effect of a concave mirror is the same as that of a convex lens, in regard to the formation of images, and the course pursued by the rays of light, except that the effect is produced in the one case by refraction, and in the other by reflection. The following figure represents the manner in

Fig. 22.

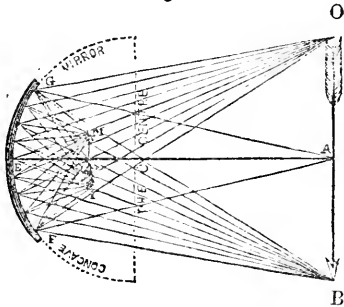

which images are formed by concave mirrors; *G F* represents the reflecting surface of the mirror; *O A B*, the object; and *I A M* the image formed by the mirror. The rays proceeding from *O* will be carried to the mirror in the direction *O G*, and, according to the law that the angle of incidence is equal to the angle of reflection, will be reflected to *I* in the direction *GI*. In like manner, the rays from *B* will be reflected from *F* to *M*, the rays from *A* will be reflected to *A*, and so of all the intermediate rays, so that an inverted image of the object *O B* will be formed at *I M*. If the rays proceeded from objects at a very great distance, the image would be formed in the real focus of the mirror, or at one-fourth the diameter of the sphere from its surface; but nearer objects, which send forth diverging rays, will have their images formed a little farther from the surface of the mirror.

If we suppose a real object placed at *I M*, then *O B* will represent its magnified image, which will be larger than the object in proportion to its distance from the mirror. This may be experimentally illustrated by a concave mirror and a candle. Suppose a concave mirror whose focal distance is five inches, and that a candle is placed before it at a little beyond its focus (as at *I M*), suppose at five and a half inches, and that a wall or white screen receives the image, at the distance of five feet six inches from the mirror, an image of the candle will be formed on the wall which will be twelve times longer and broader than the candle itself. In this way concave mirrors may be made to magnify the images of objects to an indefinite extent. This experiment is an exact counterpart of what is effected in similar circumstances by a convex lens, as described p. 29; the mirror performing the same thing by reflection as the lens did by refraction.

From what has been stated in relation to concave mirrors, it will be easily understood how they make such powerful burning-glasses. Suppose

the focal distance of a concave mirror to be twelve inches, and its diameter or breadth twelve inches. When the sun's rays fall on such a mirror, they form an image of the sun at the focal point, whose diameter is found to be about one-tenth of an inch. All the rays which fall upon the mirror are converged into this small point, and, consequently, their intensity is in proportion as the square of the surface of the mirror is to the square of the image. The squares of these diameters are as 14,400 to 1, and, consequently, the density of the sun's rays, in the focus, is to their density on the surface of the mirror as 14,400 to 1. That is, the heat of the solar rays in the focus of such a mirror will be fourteen thousand four hundred times greater than before: a heat which is capable of producing very powerful effects in melting and setting fire to substances of almost every description.

Were we desirous of forming an image by a concave speculum which shall be exactly equal to the object, the object must be placed exactly in the center; and, by an experiment of this kind, the center of the concavity of a mirror may be found.

In the cases now stated, the images of objects are all formed in the front of the mirror, or between it and the object. But there is a case in which the image is formed behind the mirror. This happens when the object is placed between the mirror and the focus of parallel rays, and then the image is larger than the object. In fig. 23, *G F* is a concave mirror, whose focus of parallel rays is at *E*. If an object *O B* be placed a little within this focus, as at *A*, a large image, *I M*, will

Fig. 23.

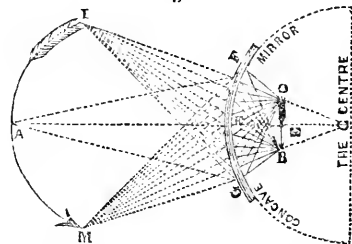

be seen *behind* the mirror, somewhat curved and erect, which will be seen by an eye looking directly into the front of the mirror. Here the image ap-

Fig. 24.

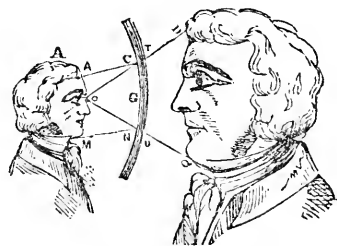

pears at a greater distance behind the mirror than the object is before it, and the object appears magnified in proportion to its distance from the focus and the mirror. If the mirror be one inch focal distance, and the object be placed eight-tenths of an inch from its surface, the image would be five times as large as the object in length and breadth, and, consequently, twenty-five times larger in

surface. In this way small objects may be magnified by reflection, as such objects are magnified by refraction, in the case of deep convex lenses. When such mirrors are large, for example six inches diameter, and eight or ten inches focal distance, they exhibit the human face as of an enormous bulk. This is illustrated by the foregoing figure: Let  $c n$ , fig. 24, represent the surface of a concave mirror, and  $A$ , a human face looking into it, the face will appear magnified as represented by the image behind the mirror,  $p. o$ . Suppose a ray,  $a c$ , proceeding from the forehead, and another,  $m x$ , from the chin; these rays are reflected to the person's eye at  $o$ , which, consequently, sees the image of the lines of reflection  $o d. o q$ , and in the angle  $d o q$ , and, consequently, magnified much beyond the natural size, and at a small distance behind the mirror.

If we suppose the side  $t u$  to represent a convex mirror, and the figure  $p o q$  a head of an ordinary size, then the figure  $A$  will represent the diminished appearance which a person's face exhibits when viewed in such a mirror. It will not only appear reduced, but somewhat distorted; because, from the form of the mirror, one part of the object is nearer to it than another, and, consequently, will be reflected under a different angle.

The effect we have now mentioned as produced by concave mirrors will only take place when the eye is nearer the mirror than its principal focus. If the spectator retire beyond this focus—suppose to the distance of five or six feet—he will not see the image behind the mirror, but he will see his image in a diminished form, hanging upside down, and suspended in the air, in a line between his eye and the mirror. In this case, his image is formed before the mirror, as represented at  $I M$ , fig. 22. In this situation, if you hold out your hand toward the mirror, the hand of the image will come out toward your hand, and, when at the center of concavity, it will be of an equal size with it, and you may shake hands with this aerial image. If you move your hand farther, you will find the hand of the image pass by your hand, and come between it and your body. If you move your hand toward either side, the hand of the image will move toward the other side; the image moving always in a contrary direction to the object. All this while the bystanders, if any, see nothing of the image, because none of the reflected rays that form it can enter their eyes. The following figure represents a phenomenon produced in the same manner.  $A B$  is a concave mirror of a large size;  $c$  represents a hand presented before the mirror, at a point farther distant than its focus. In this case an inverted image of the hand is formed, which is seen hanging down in the air at  $m$ . The rays  $c$  and  $d$  go diverging from the two opposite points of the object, and, by the action of the mirror, they are again made to converge to points at  $c$  and  $s$ , where they cross, form an image, and again proceed divergent to the eye.\*

In consequence of the properties of concave mirrors now described, many curious experiments and optical deceptions have been exhibited. The

\* Small glass mirrors for performing some of the experiments, and illustrating some of the principles above alluded to, may be made of the thickest kind of common watch glasses, by polishing or covering with tin leaf and quick-silver the convex surfaces of such glasses. Their focal distances will generally be from one to two inches. Such mirrors afford a very large and beautiful view of the eye, when held within their focal distance of that organ. Such mirrors will also serve the purpose of reflecting light on the objects viewed by microscopes. Larger mirrors, of from four to eight inches diameter, may be had of the optician at different prices, varying from five to ten or fifteen shillings.

appearance of images in the air, suspended between the mirror and the object, have sometimes been displayed with such dexterity, and an air of mystery, as to have struck with astonishment those who were ignorant of the cause. In this way birds, flying angels, specters, and other objects have been exhibited; and when the hand attempts to lay hold on them, it finds them to be nothing, and they seem to vanish into air. An apple or a beautiful flower is presented, and when a spectator attempts to touch it, it instantly vanishes, and a death's head immediately appears, and

Fig. 25.

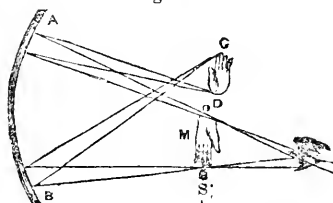

seems to snap his fingers. A person with a drawn sword appears before him, in an attitude as if about to run him through, or one terrific phantom starts up after another, or sometimes the resemblances of deceased persons are made to appear, as if, by the art of conjuration, they had been forced to return from the world of spirits. In all such exhibitions a very large concave mirror is requisite, a brilliant light must be thrown upon the objects, and every arrangement is made, by means of partitions, &c., to prevent either the light, the mirror, or the object from being seen by the spectators. The following representation (fig. 26) shows one of the methods by which this is effected:  $A$  is a large concave mirror, either of metal or of glass, placed on the back part of a dark box;  $d$  is the performer, concealed from the spectators by the cross partition  $c$ ;  $e$  is a strong light, which is likewise concealed by the partition  $f$ , which is thrown upon the actor  $d$  or upon anything he may hold in his hand. If he hold a book, as represented in the figure, the light reflected from it will pass between the partitions  $c$  and  $l$  to the mirror, and will be reflected from thence to  $z$ , where the image of the book will appear so distinct and tangible, that a spectator looking through the opening at  $x$  will imagine that it is in his power to take hold of it. In like manner, the

Fig. 26.

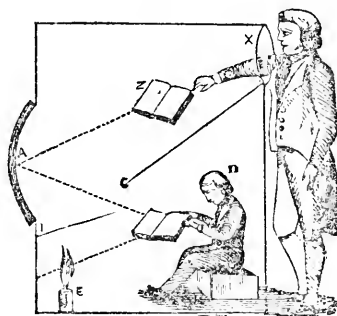

person situated at  $p$  may exhibit his own head or body, a portrait, a painting, a specter, a landscape, or any object or device which he can strongly illuminate.

There is another experiment, made with a concave mirror, which has somewhat puzzled philosophers to account for the phenomena. Take a glass bottle, A C (fig. 27), and fill it with water to the point B; leave the upper part, B C, empty, and cork it in the common manner. Place this

Fig. 27.

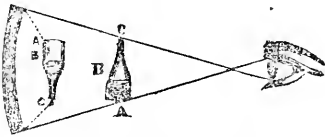

bottle opposite a concave mirror, and beyond its focus, that it may appear reversed, and before the mirror place yourself still farther distant from the bottle, and it will appear in the situation A B C. Now it is remarkable, in this apparent bottle, that the water, which, according to the laws of catoptries, should appear at A B, appears, on the contrary, at B C, and, consequently, the part A B appears empty. If the bottle be inverted and placed before the mirror, its image will appear in its natural erect position, and the water, which is in reality at B C (fig. 28), is seen at A B. If, while

Fig. 28.

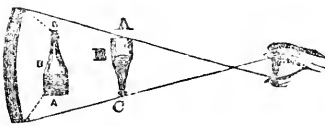

the bottle is inverted, it be uncorked, and the water run gently out, it will appear that, while the part, B C is emptying, that of A B in the image is filling, and, what is remarkable, as soon as the bottle is empty the illusion ceases, the image also appearing entirely empty. The remarkable circumstances in this experiment are, first, not only to see the object where it is not, but also where its image is not; and, secondly, that of two objects which are really in the same place, as the surface of the bottle and the water it contains, the one is seen at one place, and the other at another; and to see the bottle in the place of its image, and the water where neither it nor its image is.

The following experiments are stated by Mr. Ferguson, in his "Lectures on Select Subjects," &c.: "If a fire be made in a large room, and a smooth mahogany table be placed at a good distance near the wall, before a large concave mirror, so placed that the light of the fire may be reflected from the mirror to its focus upon the table; if a person stand by the table, he will see nothing upon it but a longish beam of light: but if he stand at a distance toward the fire, not directly between the fire and mirror, he will see an image of the fire upon the table, large and erect. And if another person, who knows nothing of the matter beforehand, should chance to come into the room, and should look from the fire toward the table, he would be startled at the appearance, for the table would seem to be on fire, and by being near the wainscot, to endanger the whole house. In this experiment there should be no light in the room but what proceeds from the fire, and the mirror ought to be at least fifteen inches in diameter. If the fire be darkened by a screen, and a large candle be placed at the back of the screen, a person standing by the candle will see the appearance of

a very fine large star, or, rather, planet, upon the table, as bright as Venus or Jupiter. And if a small wax taper—whose flame is much less than the flame of the candle—be placed near the candle, a satellite to the planet will appear on the table; and if the taper be moved round the candle, the satellite will go round the planet."

Many other illustrations of the effects of concave specula might have been given, but I shall conclude this department by briefly stating some of the *general properties of speculums*.

1. There is a great resemblance between the properties of *convex* lenses and *concave* mirrors. They both form an inverted focal image of any remote object, by the convergence of the pencil of rays. In those instruments whose performances are the effects of reflection, as reflecting telescopes, the concave mirror is substituted in the place of the convex lens. The whole effect of these instruments, in bringing to view remote objects in heaven and on earth, entirely depends on the property of a concave mirror in forming images of objects in its focus. 2. The image of an object placed beyond the center is less than the object; if the object be placed between the principal focus and the center, the image is greater than the object. In both cases the image is inverted. 3. When the object is placed between the focus and the mirror, the image situated behind the mirror is greater than the object, and it has the same direction; in proportion as the object approaches the focus, the image becomes larger and more distant. These and similar results are proved by placing a lighted candle at different distances from a concave mirror. 4. An eye cannot see an image in the air except it be placed in the diverging rays; but if the image be received on a piece of white paper, it may be seen in any position of the eye, as the rays are then reflected in every direction. 5. If a picture, drawn according to the rules of perspective, be placed before a large concave speculum, a little nearer than its principal focus, the image of the picture will appear extremely natural, and very nearly like the real objects whence it was taken. Not only are the objects considerably magnified, so as to approach to their natural size, but they have also different apparent distances, as in nature, so that the view of the inside of a church appears very like what it is in reality, and representations of landscapes appear very nearly as they do from the spot whence they were taken. In this respect a large concave speculum may be made to serve nearly the same purpose as the Optical Diagonal Machine in viewing perspective prints. 6. The concave speculum is that alone which is used as the great mirror which forms the first image in reflecting telescopes; and it is likewise the only kind of speculum used as the small mirror, in that construction of the instrument called the *Gregorian Reflector*.

#### QUANTITY OF LIGHT REFLECTED BY POLISHED SURFACES.

As this is a circumstance connected with the construction of reflecting telescopes, it may not be improper, in this place, to state some of the results of the accurate experiments of M. Bouguer on this subject. This philosopher ascertained that of the light reflected from mercury, or quicksilver, more than *one-fourth* is lost, though it is probable that no substance reflects more light than this. The rays were received at an angle of eleven and a half degrees of incidence, measured from the surface of the reflecting body, and not

from the perpendicular. The reflection from water was found to be almost as great as that of quicksilver; so that in very small angles it reflects nearly three-fourths of the direct light. This is the reason why so strong a reflection appears on the water, when one walks, in still weather, on the brink of a lake opposite to the sun. The direct light of the sun diminishes gradually as it approaches the horizon, while the reflected light at the same time grows stronger; so that there is a certain elevation of the sun in which the united force of the direct and reflected light will be the greatest possible, and this is when he is twelve or thirteen degrees in altitude. On the other hand, light reflected from water at great angles of incidence is extremely small. When the light was perpendicular, it reflected no more than the thirty-seventh part which mercury does in the same circumstances, and only the fifty-fifth part of what fell upon it in this case.

Using a smooth piece of glass, one line in thickness, he found that, when it was placed at an angle of fifteen degrees with the incident rays, it reflected 628 parts of 1000 which fell upon it; at the same time, a metallic mirror, which he tried in the same circumstances, reflecting only 561 of them. At a less angle of incidence much more light was reflected; so that at an angle of three degrees the glass reflected 700 parts, and the metal something less, as in the former case. The most striking observations made by this experimenter relate to the very great difference in the quantity of light reflected at different angles of incidence. He found that for 1000 incident rays, the reflected rays at different angles of incidence, were as follows:

Angles of incidence.	Rays reflected by water.	Rays reflected by g.ass.
5°	501	519
10	333	412
15	211	299
30	65	112
50	22	34
70	18	25
90	18	25

With regard to such mirrors as the specula of reflecting telescopes, it will be found in general, that they reflect little more than the one-half of the rays which fall upon them.

#### UNCOMMON APPEARANCES IN NATURE PRODUCED BY THE COMBINED INFLUENCES OF REFLECTION AND REFRACTION.

The reflection and refraction of the rays of light frequently produce phenomena which astonish the beholders, and which have been regarded by the ignorant and the superstitious as the effects of supernatural agency. Of these phenomena I shall state a few examples.

One of the most striking appearances of this kind is what has been termed the *Fata Morgana*, or optical appearances of figures in the sea and the air, as seen in the Faro of Messina. The following account is translated from a work of Minasi, who witnessed the phenomenon, and wrote a dissertation on the subject: "When the rising sun shines from that point whence its incident ray forms an angle of about forty-five degrees to the sea of Reggio, and the bright surface of the water in the bay is not disturbed either by the wind or the current, the spectator being placed on an eminence of the city, with his back to the sun

and his face to the sea; on a sudden there appear on the water, as in a catoptric theater, various multiplied objects, that is to say, numberless series of pilasters, arches, castles well delineated, regular columns, lofty towers, superb palaces, with balconies and windows, extended alleys of trees, delightful plains with herds and flocks, armies of men on foot and horseback, and many other strange images, in their natural colors and proper actions, passing rapidly in succession along the surface of the sea, during the whole of the short period of time, while the above-mentioned causes remain. But if, in addition to the circumstances now described, the atmosphere be highly impregnated with vapor and dense exhalations, not previously dispersed by the winds or the sun, it then happens that, in this vapor, as in a curtain extended along the channel at the height of about thirty palms, and nearly down to the sea, the observer will behold the scene of the same objects, not only reflected from the surface of the sea, but likewise in the air, though not so distant or well-defined as the former objects from the sea. Lastly, if the air be slightly hazy or opaque, and, at the same time, dewy and adapted to form the iris, the then above-mentioned objects will appear only at the surface of the sea, as in the first case, but all vividly colored or fringed with red, green, blue, and other prismatic colors.\*

It is somewhat difficult to account for all the appearances here described, but, in all probability, they are produced by a calm sea, and one or more strata of superincumbent air, differing in refractive, and, consequently, in reflective power. At any rate, reflection and refraction are some of the essential causes which operate in the production of the phenomena.

The *Mirage*, seen in the deserts of Africa, is a phenomenon, in all probability, produced by a similar cause. M. Mouge, who accompanied the French army to Egypt, relates that, when in the desert between Alexandria and Cairo, the mirage of the blue sky was inverted, and so mingled with the sand below as to give to the desolate and arid wilderness an appearance of the most rich and beautiful country. They saw, in all directions, green islands, surrounded with extensive lakes of pure, transparent water. Nothing could be conceived more lovely and picturesque than the landscape. In the tranquil surface of the lakes, the trees and houses with which the islands were covered were strongly reflected with vivid and varied hues, and the party hastened forward to enjoy the cool refreshments of shade and stream which these populous villages proffered to them. When they arrived, the lake on whose bosom they floated, the trees among whose foliage they were embowered, and the people who stood on the shore inviting their approach, had all vanished, and nothing remained but a uniform and irksome desert of sand and sky, with a few naked huts and ragged Arabs. Had they not been undeceived by their nearer approach, there was not a man in the visionary trees and lakes had a real existence in the midst of the desert.

Dr. Clark observed precisely the same appearance at Rosetta. The city seemed surrounded with a beautiful sheet of water; and so certain was his Greek interpreter—who was unacquainted with the country—of this fact, that he was quite indignant at an Arab who attempted to explain to him that it was a mere optical delusion. At length

\* Nicholson's Journal of Natural Philosophy, &c., 4th series, p. 225.

they reached Rosetta in about two hours, without meeting with any water; and on looking back on the sand they had just crossed, it seemed to them as if they had waded through a vast blue lake.

Fig. 29.

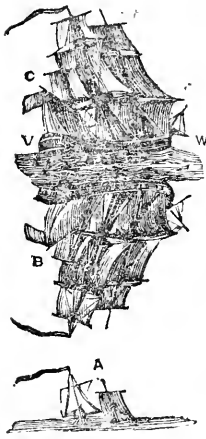

On the 1st of August, 1798, Dr. Vince observed at Ramsgate a ship which appeared as at A (fig. 29), the topmast being the only part of it that was seen above the horizon. An inverted image of it was seen at B, immediately above the real ship A, and an erect image at C, both of them being complete and well-defined. The sea was distinctly seen between them, as at v w. As the ship rose to the horizon, the image C gradually disappeared, and, while this was going on, the image B descended, but the mainmast of B did not meet the mainmast of A. The two images, B, C, were perfectly visible when the whole ship was actually below the horizon. Dr. Vince then directed his telescope to another ship whose hull was just in the horizon, and he observed a complete inverted image of it, the mainmast of which just touched the mainmast of the ship itself. He saw at the same time several other ships whose images appeared in nearly a similar manner, in one of which the two images were visible when the whole ship was beneath the horizon. These phenomena must have been produced by the same cause which operated in the case formerly mentioned, in relation to Capt. Scoresby, when he saw the figure of his father's ship inverted in the distant horizon. Such cases are, perhaps, not uncommon, especially in calm and sultry weather, but they are seldom observed, except when a person's attention is accidentally directed to the phenomenon, and, unless he uses a telescope, it will not be so distinctly perceived.

The following phenomenon, of a description nearly related to the above, has been supposed to be chiefly owing to *refraction*: On the 18th of November, 1804, Dr. Buchan, when watching the rising sun, about a mile to the east of Brighton, just as the solar disc emerged from the surface of the water, saw the face of the cliff on which he was standing, a windmill, his own figure, and the figure of his friend, distinctly represented, precisely opposite, at some distance from the ocean. This appearance lasted about ten minutes, until the sun had risen nearly his own diameter above the sea. The whole then seemed to be elevated into the air, and successively disappeared. The surface of the sun was covered with a dense fog of many rays in height, which gradually receded from the yards of the sun as he ascended from the horizon.

The following appearance, most probably, ascribed to the *refraction* of the atmosphere: It was beheld at Ramsgate by Dr. Vince, of Cambridge, and another gentleman. It is well known that the four turrets of Dover Castle are seen at Ramsgate, over a hill which intervenes between a full prospect of the whole. On the 2d of August, 1806, not only were the four turrets visible, but the castle itself appeared as though situated on that side of the hill nearest Ramsgate, and so striking was the appearance that for a long time the doc-

tor thought it an illusion; but at last by accurate observation, was convinced that it was an actual image of the castle. He, with another individual, observed it attentively for twenty minutes, but was prevented by rain from making further observations. Between the observers and the land from which the hill rises there were about six miles of sea, and from thence to the top of the hill there was about the same distance; their own height above the surface of the water was about seventy feet. The cause of this phenomenon was undoubtedly *unequal refraction*. The air being more dense near the ground and above the sea than at greater heights, reached the eye of the observer, not in straight but in curvilinear lines. If the rays of the castle had in their path struck an eye at a much greater distance than Ramsgate, the probability is that the image of the castle would have been inverted in the air; but, in the present case, the rays from the turret and the base of the castle had not crossed each other.

To similar causes as those now alluded to are to be attributed such phenomena as the following:

*The specter of the Brocken.* This is wonderful, and, at first sight, a terrific phenomenon, which is sometimes seen from the summit of the Hartz Mountains in Hanover, which is about 3300 feet above the level of the sea, and overlooks all the country fifteen miles round. From this mountain the most gigantic and terrific specters have been seen, which have terrified the credulous and gratified the curious, in a very high degree. M. Hawe, who witnessed this phenomenon, says the sun rose about four o'clock, after he had ascended to the summit, in a serene sky, free of clouds; and, about a quarter past five, when looking round to see if the sky continued clear, he suddenly beheld at a little distance, a human figure of a monstrous size turned toward him, and glaring at him. While gazing on this gigantic specter, with a mixture of awe and apprehension, a sudden gust of wind nearly carried off his hat, and he clapped his hand to his head to detain it, when to his great delight, the colossal specter did the same. He changed his body into a variety of attitudes, all which the specter exactly imitated, and then suddenly vanished without any apparent cause, and in a short time as suddenly appeared. Being joined by another spectator, after the first visions had disappeared, they kept steadily looking for the aerial specters, when two gigantic monsters suddenly appeared. These specters had been long considered as preternatural by the inhabitants of the adjacent districts, and the whole country had been filled with awe and terror. Some of the lakes of Ireland are found to be susceptible of producing illusions, particularly the Lake of Killarney. This romantic sheet of water is bounded on one side by a semicircle of rugged mountains, and on the other by a flat morass; and the vapors generated in the marsh, and broken by the mountains, continually represent the most fantastic objects. Frequently men riding along the shore are seen as if they were moving across the lake, which is supposed to have given rise to the legend of O'Donoghue, a magician, who is said to be visible on the lake every May morning.

There can be little doubt that most of those visionary appearances which have been frequently seen in the sky and in mountainous regions, are phantoms produced by the cause to which I am adverting, such as armies of footmen and norsemen, which some have asserted to have been seen in the air near the horizon. A well-authenticated instance of this kind occurred in the highlands of Scotland: Mr. Wren, of Wetton Hall, and

D. Stricket, his servant, in the year 1744, were sitting at the door of the house in a summer evening, when they were surprised to see opposite to them, on the side of Sonterfell hill—a place so extremely steep that scarce a horse could walk slowly along it—the figure of a man with a dog pursuing several horses, all running at a most rapid pace. Onward they passed, until at last they disappeared at the lower end of the Fell. In expectation of finding the man dashed to pieces by so tremendous a fall, they went early next morning and made a search, but no trace of man or horse, or the prints of their feet on the turf could be found. Some time afterward, about seven in the evening, on the same spot, they beheld a troop of horsemen advancing in close ranks and at a brisk pace. The inmates of every cottage for a mile round beheld the wondrous scene, though they had formerly ridiculed the story told by Mr. Wren and his servant, and were struck with surprise and fear. The figures were seen for upward of two hours, until the approach of darkness rendered them invisible. The various evolutions and changes through which the troops passed were distinctly visible, and were marked by all the observers. It is not improbable that these aerial troopers were produced by the same cause which made the castle of Dover to appear on the side of the hill next to Ramsgate, and it is supposed that they were images of a body of rebels, on the other side of the hill, exercising themselves previous to the rebellion in 1745.\*

I shall mention only another instance of this description which lately occurred in France, and for a time caused a powerful sensation among all ranks. On Sunday, the 17th of December, 1826, the clergy in the parish of Migné, in the vicinity of Poitiers, were engaged in the exercises of the Jubilee which preceded the festival of Christmas, and a number of persons, to the amount of 3,000 souls assisted in the service. They had planted, as part of the ceremony, a large cross, twenty-five feet high, and painted red, in the open air beside the church. While one of the preachers, about five in the evening, was addressing the multitude, he reminded them of the miraculous cross which appeared in the sky to Constantine and his army, and the effect it produced, when suddenly a similar celestial cross appeared in the heavens just before the porch of the church, about 200 feet above the horizon, and 140 feet in length, and its breadth from three to four feet, of a bright silver color, tinged with red. The curate and congregation fixed their wondering gaze upon this extraordinary phenomenon, and the effect produced on the minds of the assembly was strong and solemn; they spontaneously threw themselves on their knees; and many, who had been remiss in their religious duties, humbly confessed their sins, and made vows of penance and reformation. A commission was appointed to investigate the truth of this extraordinary appearance, and a memorial stating the above and other facts, was subscribed by more than forty persons of rank and intelligence, so that no doubt was entertained as to the reality of the phenomenon. By many it was considered as strictly miraculous, as having happened at the time and in the circumstances mentioned. But it is evident, from what we have already stated, that it may be ac-

counted for on physical principles. The large cross of wood painted red was doubtless the real object which produced the magnified image. The state of the atmosphere, according to the descriptions given in the memorial, must have been favorable for the production of such images.—The spectrum of the wooden cross must have been cast on the concave surface of some atmospheric mirror, and so reflected back to the eyes of the spectators from an opposite place, retaining exactly the same shape and proportions, but dilated in size; and, what is worthy of attention, it was tinged with red, the very color of the object of which it was the reflected image.

Such phenomena as we have now described, and the causes of them which science is able to unfold, are worthy of consideration, in order to divest the mind of superstitious terrors, and enable it clearly to perceive the laws by which the Almighty directs the movements of the material system. When any appearance in nature, exactly the reverse of everything we could have previously conceived, presents itself to view, and when we know of no material cause by which it could be produced, the mind must feel a certain degree of awe and terror, and will naturally resort to supernatural agency as acting either in opposition to the established laws of the universe, or beyond the range to which they are confined. Beside the fears and apprehensions to which such erroneous conceptions give rise, they tend to convey false and distorted impressions of the attributes of the Deity, and of His moral government.—Science, therefore, performs an invaluable service to man, by removing the cause of superstitious alarms, by investigating the laws and principles which operate in the physical system, and by assigning reasons for those occasional phenomena which at first sight appeared beyond the range of the operation of natural causes.

The late ingenious Dr. Wollaston illustrated the causes of some of the phenomena we have described, in the following manner: He looked along the side of a red-hot poker at a word or object ten or twelve feet distant; and at a distance less than three-eighths of an inch from the line of the poker, an inverted image was seen, and within and without that image, an erect image, in consequence of the change produced, by the heat of the poker, in the density of the air. He also suggested the following experiment as another illustration of the same principle, namely, on viewing an object through a stratum of spirit of

Fig. 30.

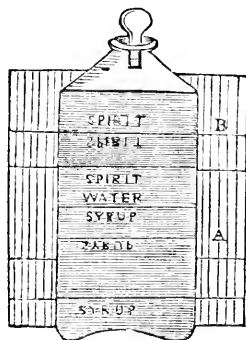

wine lying above water, or a stratum of water laid above one of sirup. He poured into a square vial a small quantity of clear sirup, and above

\*There can be little doubt that some of the facts ascribed, in the western highlands of Scotland, to second sight, have been owing to the unusual refraction of the atmosphere; as one of the peculiarities attributed to those who possessed this faculty was, that they were enabled to descry boats and ships before they appeared in the horizon.

this he poured an equal quantity of *water*, which, gradually combined with the *sirap*, as seen at *A*, fig. 30. The word "*sirap*," on a card held behind the bottle appeared erect when seen through the pure spirit, but inverted when seen through the mixture of water and *sirap*. He afterward put nearly the same quantity of rectified spirits of wine above the water, as seen at *B*, and he saw the appearance as represented, namely, the true place of the word "*Spirit*," and the inverted and erect images below. These substances, by their gradual incorporation, produce refracting power, diminishing from the *spirit of wine* to the *water*, or from the *sirap* to the *water*; so that, by looking through the mixed stratum, an inverted image of any object is seen behind the bottle. These experiments show that the *mirage* and several other atmospherical phenomena may be produced by variations in the refractive power of different strata of the atmosphere.

It is not unlikely that phenomena of a new and different description from any we have hitherto observed, may be produced from the same causes to which we have adverted. A certain optical writer remarks: "If the variation of the refractive power of the air takes place in a horizontal line perpendicular to the line of vision, that is, from right to left, then we may have a *lateral mirage*, that is, an image of a ship may be seen on the right or left hand of the real ship, or on both, if the variation of refractive power is the same on each side of the line of vision, and a fact of this kind was once observed on the Lake of Geneva. If there should happen at the same time both a vertical and a lateral variation of refractive power in the air, and if the variation should be such as to expand or elongate the object in both directions, then the object would be magnified as if seen through a telescope, and might be seen and recognized at a distance at which it would otherwise have been invisible. If the refracting power, on the contrary, varied so as to construct the object in both directions, the image of it would be diminished as if seen through a concave lens."

#### REMARKS AND REFLECTIONS IN REFERENCE TO THE PHENOMENA DESCRIBED ABOVE.

Such, then, are some of the striking and interesting effects produced by the refraction and the reflection of the rays of light. As the formation of the *images* of objects by convex lenses lays the foundation of the construction of refracting telescopes and microscopes, and of all the discoveries they have brought to light, so the property of *concave specula*, in forming similar images, is that on which the construction of *reflecting* telescopes entirely depends. To this circumstance Herschel was indebted for the powerful telescopes he was enabled to construct—which were all formed on the principle of reflection—and for all the discoveries they enabled him to make in the planetary system, and in the sidereal heavens. The same principles which operate in optical instruments, under the agency of man, we have reason to believe, frequently act on a more expansive scale in various parts of the system of nature. The magnificent *cross* which astonished the preacher and the immense congregation assembled at Migne, was, in all probability, caused by a vast atmospherical speculum formed by the hand of nature, and representing its objects on a scale far superior to that of human art; and probably to the same cause is to be attributed the singular phenomenon of the coast of France having been made to

appear within two or three miles of the town of Hastings, as formerly described (see p. 24).—Many other phenomena which we have never witnessed, and of which we can form no conception, may be produced by the same cause operating in an infinity of modes.

The facts we have stated above, and the variety of modes by which light may be refracted and reflected by different substances in nature, lead us to form some conception of the magnificent and diversified scenes which light may produce in other systems and worlds under the arrangements of the all-wise and beneficent Creator. Light, in all its modifications and varieties of color and reflection, may be considered as the beauty and glory of the universe, and the source of unnumbered enjoyments to all its inhabitants. It is a symbol of the Divinity himself; for "God is LIGHT, and in Him is no darkness at all." It is a representative of Him who is exhibited in the sacred oracles as "The Sun of Righteousness," and "the LIGHT of the world." It is an emblem of the glories and felicities of that future world where knowledge shall be perfected and happiness complete; for its inhabitants are designated "the saints in light;" and it is declared in sacred history to have been the first-born of created beings. In our lower world, its effects on the objects which surround us, and its influences upon all sensitive beings, are multifarious and highly admirable. While passing from infinitude to infinitude, it reveals the depth and immensity of the heavens, the glory of the sun, the beauty of the stars, the arrangements of the planets, the rainbow encompassing the sky with its glorious circle, the embroidery of flowers, the rich clothing of the meadows, the valleys standing thick with corn, "the cattle on a thousand hills," the rivers rolling through the plains, and the wide expanse of the ocean. But in other worlds the scenes it creates may be far more resplendent and magnificent. This may depend upon the refractive and reflective powers with which the Creator has endowed the atmospheres of other planets, and the peculiar constitution of the various objects with which they are connected. It is evident, from what we already know of the reflection of light, that very slight modifications of certain physical principles, and very slight additions to the arrangements of our terrestrial system, might produce scenes of beauty, magnificence, and splendor, of which at present we can form no conception. And it is not unlikely that by such diversities of arrangement in other worlds an *infinite variety* of natural scenery is produced throughout the universe.

In the arrangements connected with the planet Saturn, and the immense rings with which it is encompassed, and in the various positions which its satellites daily assume with regard to one another, to the planet itself, and to these rings, there is, in all probability, a combination of refractions, reflections, light, and shadows, which produce scenes wonderfully diversified, and surpassing in grandeur what we can now distinctly conceive. In the remote regions of the heavens there are certain bodies composed of immense masses of luminous matter, not yet formed into any regular system, and which are known by the name of *nebulae*. What should hinder us from supposing that certain exterior portions of those masses form speculums of enormous size, as some parts of our atmosphere are sometimes found to do? Such specula may be conceived to be hundreds and even thousands of miles in diameter, and that they may form images of the most distant objects



in the heavens, on a scale of immense magnitude and extent, and which may be reflected, in all their grandeur, to the eyes of intelligences at a vast distance. And, if the organs of vision of such beings be far superior to ours in acuteness and penetrating power, they may thus be enabled to take a survey of an immense sphere of vision, and to descry magnificent objects at distances the most remote from the sphere they occupy. Whatever grounds there may be for such suppositions, it must be admitted that all the knowledge we

have hitherto acquired respecting the operation of light, and the splendid effects it is capable of producing, is small indeed, and limited to a narrow circle, compared with the immensity of its range, the infinite modifications it may undergo, and the wondrous scenes it may create in regions of creation to which human eyes have never yet penetrated, and which may present to view objects of brilliancy and magnificence such as "Eye hath not yet seen, nor ear heard, nor hath it entered into the heart of man to conceive."

## CHAPTER V.

### SECTION I.

#### ON THE COLORS OF LIGHT.

WE have hitherto considered light chiefly as a simple homogeneous substance, as if all its rays were white, and as if they were all refracted in the same manner by the different lenses on which they fall. Investigations, however, into the nature of this wonderful fluid have demonstrated that this is not the case, and that it is possessed of certain additional properties of the utmost importance in the system of nature. Had every ray of light been a pure white, and incapable of being separated into any other colors, the scene of the universe would have exhibited a very different aspect from what we now behold. One uniform hue would have appeared over the whole face of nature, and one object could scarcely have been distinguished from another. The different shades of verdure which now diversify every landscape, the brilliant coloring of the flowery fields, and almost all the beauties and sublimities which adorn this lower creation would have been withdrawn. But it is now ascertained that every ray of white light is composed of an assemblage of colors, whence proceed that infinite variety of shade and color with which the whole of our terrestrial habitation is arrayed. Those colors are found not to be in the objects themselves, but in the rays of light which fall upon them, without which they would either be invisible or wear a uniform aspect. In reference to this point, Goldsmith has well observed: "The blushing beauties of the rose, the modest blue of the violet, are not in the flowers themselves, but in the light that adorns them. Odor, softness and beauty of figure are their own; but it is light alone that dresses them up in those robes which shame the monarch's glory."

Many strange opinions and hypotheses were entertained respecting colors by the ancients, and even by many modern writers, prior to the time of Sir Isaac Newton. The Pythagoreans called color the *superficies* of bodies; Plato said that it was a flame issuing from them. According to Zeno, it is the first configuration of matter, and according to Aristotle, it is that which moves bodies actually transparent. Among the moderns, Des Cartes imagined that the difference of color proceeds from the prevalence of the direct or rotatory motion of the particles of light. Grimaldi, Dechales, and others, thought the differences of color depended upon the quick or slow vibrations of a certain elastic medium filling the whole universe. Rohault imagined that the different colors were made by the rays of light entering the eye

at different angles with respect to the optic axis; and Dr. Hook conceived that color is caused by the sensation of the oblique or uneven pulse of light; and this being capable of no more than two varieties, he concluded that there could be no more than two primary colors. Such were some of the crude opinions which prevailed before the era of the illustrious Newton, by whose enlightened investigations the true theory of colors was at last discovered. In the year 1656 this philosopher began to investigate the subject, and finding the colored image of the sun, formed by a glass prism, to be of an oblong, and not of a circular form, as, according to the laws of refraction, it ought to be, he was surpris'd at the great disproportion between its length and breadth, the former being five times the length of the latter; and he began to conjecture that light is not *homogeneous*, but that it consists of rays, some of which are much more refrangible than others. Prior to this period, philosophers supposed that *all* light, in passing out of one medium into another of different density, was *equally* refracted in the same or like circumstances; but Newton discovered that this is not the fact; but that there are *different species* of light, and that each species is disposed both to suffer a different degree of refrangibility in passing out of one medium into another, and to excite in us the idea of a *different color* from the rest; and that bodies appear of that color which arises from the peculiar rays they are disposed to reflect. It is now, therefore, universally acknowledged that the light of the sun, which to us seems perfectly homogeneous and white, is composed of no fewer than *seven* different colors, namely, *Red, Orange, Yellow, Green, Blue, Indigo, and Violet*. A body which appears of a red color has the property of reflecting the red rays more powerfully than any of the others; a body of a green color reflects the green rays more copiously than rays of any other color, and so of the orange, yellow, blue, purple, and violet. A body which is of a *black* color, instead of reflecting, *absorbs* all, or the greater part of the rays that fall upon it; and, on the contrary, a body that appears *white* reflects the greater part of the rays indiscriminately, without separating the one from the other.

Before proceeding to describe the experiments by which the above results were obtained, it may be proper to give some idea of the form and effects of the *prism* by which such experiments are made. This instrument is triangular and straight, and generally about three or four inches long. It is commonly made of white glass, as free as possible from veins and bubbles, and other similar defects, and is solid throughout. Its lateral faces, or sides,

should be perfectly plane, and of a fine polish. The angle formed by the two faces, one receiving the ray of light that is refracted in the instrument, and the other affording it an issue on its returning into the air, is called the *refracting angle* of the prism, as  $ACB$  (fig. 31). The manner in which Newton performed his experiments, and established the discovery to which we have alluded, is as follows:

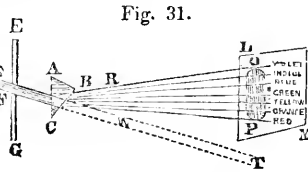

Fig. 31.

In the window-shutter,  $EG$  (fig. 31.) of a dark room, a hole,  $F$ , was made, of about one-third of an inch diameter, and behind it was placed a glass prism,  $ACB$ , so that the beam of light,  $SP$ , proceeding directly from the sun, was made to pass through the prism. Before the interposition of the prism, the beam proceeded in a straight line toward  $T$ , where it formed a round, white spot; but, being now bent out of its course by the prism, it formed an oblong image,  $OP$ , upon the white pasteboard, or screen,  $LM$ , containing the seven colors marked in the figure, the *red* being the *least*, and the *violet* the *most* refracted from the original direction of the solar beam,  $ST$ . This oblong image is called the *prismatic spectrum*. If the refracting angle of the prism,  $ACB$ , be  $64$  degrees, and the distance of the pasteboard from the prism about  $18$  feet, the length of the image,  $OP$ , will be about ten inches, and the breadth  $2$  inches. The sides of the spectrum are right lines distinctly bounded, and the ends are semicircular. From this circumstance, it is evident that it is still the image of the sun, but elongated by the refractive power of the prism. It is evident from the figure that, since some part of the beam,  $RO$ , is refracted much farther out of its natural course  $WT$  than some other part of the beam, as  $WP$ , the rays toward  $RO$  have a much greater disposition to be refracted than those toward  $WP$ ; and that this disposition arises from the naturally different qualities of those rays, is evident from this consideration, that the refracting angle or power of the prism is the same in regard to the superior part of the beam as to the inferior.

By making a hole in the screen,  $LM$ , opposite any one of the colors of the spectrum, so as to allow that color alone to pass—and by letting the color thus separated fall upon a second prism—Newton found that the light of each of the colors was alike refrangible, because the second prism could not separate them into an oblong image, or into any other color. Hence he called all the seven colors *simple* or *homogeneous*, in opposition to *white* light, which he called *compound*, or *heterogeneous*. With the prism which this philosopher used, he found the lengths of the colors and spaces of the spectrum to be as follows: Red,  $45$ ; Orange,  $27$ ; Yellow,  $40$ ; Green,  $60$ ; Blue,  $60$ ; Indigo,  $45$ ; Violet,  $80$ ; or  $369$  in all. But these spaces vary a little with prisms formed of different substances, and, as they are not separated by distinct limits, it is difficult to obtain anything like an accurate measure of their relative extents. Newton examined the ratio between the sines of incidence and refraction of these decomposed rays (see p. 18), and found that each of the seven primary color-making rays had certain limits within which they were confined. Thus, let the sine of inci-

dence in glass be divided into  $50$  equal parts, the sine of refraction into air of the *least* refrangible, and the *most* refrangible rays will contain respectively  $77$  and  $78$  such parts. The sines of refraction of all the degrees of *red* will have the intermediate degrees of magnitude, from  $77$  to  $77$  one-eighth; *Orange*, from  $77$  one-eighth to  $77$  one-fifth; *Yellow*, from  $77$  one-fifth to  $77$  one-third; *Green*, from  $77$  one-third to  $77$  one-half; *Blue*, from  $77$  one-half to  $77$  two-thirds; *Indigo*, from  $77$  two-thirds to  $77$  seven-ninths; and *Violet*, from  $77$  seven-ninths to  $78$ .

From what has been now stated, it is evident that, in proportion as any portion of an optic glass bears a resemblance to the form of a prism, the component rays that pass through it must be necessarily separated, and will consequently paint or tinge the object with colors. The edges of every convex lens approach to this form, and it is on this account that the extremities of objects, when viewed through them, are found to be tinged with the prismatic colors. In such a glass, therefore, those different colored rays will have *different foci*, and will form their respective images at different distances from the lens. Thus, suppose  $LN$  (fig. 32) to represent a double convex lens,

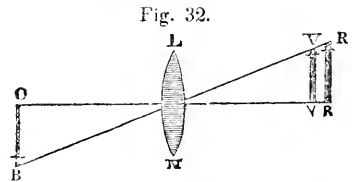

Fig. 32.

and  $OB$ , an object at some distance from it. If the object  $OB$  was of a pure red color, the rays proceeding from it would form a red image at  $RR'$ ; if the object was of a violet color, an image of that color would be formed at  $Vv$ , nearer the lens; and if the object was white, or any other combination of the color-making rays, those rays would have their respective foci at different distances from the lens, and form a succession of images, in the order of the prismatic colors, between the space  $RR'$  and  $Vv$ .

This may be illustrated in the following manner: Take a card or slip of white pasteboard, as  $ABEF$  (fig. 33), and paint one-half,  $ABCD$ ,

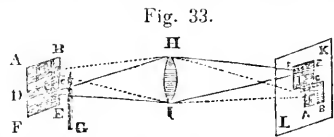

Fig. 33.

red, the other half,  $CF$ , violet or indigo, and, tying black threads across it, set it near the flame of a candle,  $G$ ; then take a lens,  $HI$ , and, holding a sheet of white paper behind it, move it backward and forward upon the edge of a graduated ruler until you see the black threads most distinctly in the image, and you will find the focus of the violet  $FE$  much nearer than that of the red  $a, c$ , which plainly shows that bodies of different colors can never be depicted by convex lenses without some degree of confusion.

The quantity of dispersion of the colored rays in convex lenses depends upon the focal length of the glass, the space which the colored images occupy being about the twenty-eighth part. Thus, if the lens be twenty-eight inches focal distance, the space between  $RR'$  and  $Vv$  (fig. 32) will be about one inch; if it be twenty-eight feet focus, the same space will be about one foot, and so on

in proportion Now, when such a succession of images, formed by the different colored rays, is viewed through an eye-glass, it will seem to form but one image, and, consequently, very indistinct, and tinged with various colors; and as the red figure, *R* *r*, is largest, or seen under the greatest angle, the extreme parts of this confused image will be red, and a succession of the prismatic colors will be formed within this red fringe, as is generally found in common refracting telescopes, constructed with a single object-glass. It is owing to this circumstance that the common refracting telescope cannot be much improved without having recourse to lenses of a very long focal distance; and hence, about 150 years ago, such telescopes were constructed of 80, and 100, and 120 feet in length. But still, the image was not formed so distinctly as was desired, and the aperture of the object-glass was obliged to be limited. This is a defect which was long regarded as without a remedy, and even Newton himself despaired of discovering any means by which the defects of refracting telescopes might be removed, and their improvement effected. This, however, was accomplished by Dollond to an extent far surpassing what could have been expected, of which a particular account will be given in the sequel.

It was originally remarked by Newton, and the fact has since been confirmed by the experiments of Sir W. Herschel, that *the different colored rays have not the same illuminating power.* The violet rays appear to have the least illuminating effect; the indigo more, and the effect increases in the order of the colors, the *green* being very great; between the green and the yellow the greatest of all; the yellow the same as the green; but the red less than the yellow. Herschel also endeavored to determine whether the power of the differently-colored rays to *heat* bodies varied with their power to illuminate them. He introduced a beam of light into a dark room, which was decomposed by a prism, and then exposed a very sensible thermometer to all the rays in succession, and observed the heights to which it rose in a given time. He found that their heating power increased from the violet to the red. The mercury in the thermometer rose higher when its bulb was placed in the indigo than when it was placed in the violet, still higher in blue, and highest of all at red. Upon placing the bulb of the thermometer below the red, quite out of the spectrum, he was surprised to find that the mercury rose highest of all, and concluded that *rays proceed from the sun, which have the power of HEATING but not of illuminating bodies.* These rays have been called *invisible solar rays*; they were about half an inch from the commencement of the red rays; at a greater distance from this point the heat began to diminish, but was very perceptible, even at a distance of  $1\frac{1}{2}$  inch. He determined that the heating power of the *red* to that of the *green* rays was  $\frac{23}{4}$  to 1, and  $3\frac{1}{2}$  to 1, in red to *violet.* He afterward made experiments to collect those invisible caloric rays, and caused them to act independently of the light, from which he concluded that they are sufficient to account for all the effects produced by the solar rays in exciting heat; that they are capable of passing through glass, and of being refracted and reflected, after they have been finally detached from the solar beam.

M. Ritter, of Jena, Wollaston, Beckman, and others, have found that the rays of the spectrum are possessed of certain *chemical properties*; that beyond the least brilliant extremity, namely, a little beyond the violet ray, there are invisible rays, which act chemically, while they have nei-

ther the power of heating nor illuminating bodies. Muriate of silver, exposed to the action of the red rays, becomes blackish; a greater effect is produced by the yellow; a still greater by the violet, and the greatest of all by the invisible rays beyond the violet. When phosphorus is exposed to the action of the invisible rays beyond the red, it emits white fumes, but the invisible rays beyond the violet extinguish them. The influence of these rays is daily seen in the change produced upon vegetable colors, which fade when frequently exposed to the direct influence of the sun. Whatever object they are destined to accomplish in the general economy of nature is not yet distinctly known; we cannot, however, doubt that they are essentially requisite to various processes going forward in the material system. And we know that not only the comfort of all the tribes of the living world, but the very existence of the animal and vegetable creation depends upon the unremitting agency of the *calorific rays.*

It has likewise been lately discovered that certain rays of the spectrum, particularly the *violet*, possess the property of communicating the magnetic power. Mr. Morichini, of Rome, appears to have been the first who found that the violet rays of the spectrum had this property. The result of his experiments, however, was involved in doubt until it was established by a series of experiments instituted by Mrs. Somerville, whose name is so well known in the scientific world. This lady having covered half a sewing-needle, about an inch long, with paper, she exposed the other half for two hours to the violet rays. The needle had then acquired north polarity. The indigo rays produced nearly the same effect; and the blue and green rays produced it in a still less degree. In the yellow, orange, red, and invisible rays no magnetic influence was exhibited, even though the experiment was continued for three successive days. The same effects were produced by enclosing the needle in blue or green glass, or wrapping it in blue or green ribbon, or half of the needle being always covered with paper.

One of the most curious discoveries of modern times, in reference to the solar spectrum, is that of Fraunhofer, of Munich, one of the most distinguished artists and opticians on the Continent.\* He discovered that the spectrum is covered with dark and colored lines, parallel to one another, and perpendicular to the length of the spectrum:

\* Fraunhofer was, in the highest sense of the word, an *optician*, an original discoverer in the most abstruse and delicate departments of this science, a competent mathematician, an admirable mechanist, and a man of a truly philosophical turn of mind. By his extraordinary talents, he was soon raised from the lowest station in a manufacturing establishment to the direction of the *optical* department of the business, in which he originally labored as an ordinary workman. He then applied the whole power of his mind to the perfection of the achromatic telescope, the defects of which, in reference to the optical properties of the materials used, he attempted to remedy; and, by a series of admirable experiments, succeeded in giving to optical determinations the precision of astronomical observations, surpassing in this respect all who had gone before him, except, perhaps, the illustrious Newton. It was in the course of these researches that he was led to the important discovery of the dark lines which occur in the solar spectrum. His achromatic telescopes are scattered over Europe, and are the largest and best that have hitherto been constructed. He died at Munich, at a premature age, in 1826; his death, it is said, being accelerated by the unwholesome nature of the processes employed in his glass-house; leaving behind him a reputation rarely attained by one so young. His memoir "On the refractive and dispersive Power of the different Species of Glass, in reference to the Improvement of Achromatic Telescopes, and an Account of the Lines of the Spectrum," will be found in the "Edinburgh Philosophical Journal," vol. ix, p. 288—299; and vol. x, p. 26—40, for 1823, '4.

and he counted no less than 590 of these lines. In order to observe these lines, it is necessary to use prisms of the most perfect construction, of very pure glass, free of veins, to exclude all extraneous light, and even to stop those rays which form the colored spaces which we are not examining. It is necessary, also, to use a magnifying instrument, and the light must enter and emerge from the prism at equal angles. One of the important practical results of this discovery is, that those lines are fixed points in the spectrum, or rather, that they have always the same position in the colored spaces in which they are found. Fraunhofer likewise discovered, in the spectrum produced by the light of Venus, the same streaks as in the solar spectrum; in the spectrum of the light of Sirius he perceived three large streaks, which, according to appearance, had no resemblance to those of the light of the sun; one of them was in the green, two in the blue. The stars appear to differ from one another in their streaks. The electric light differs very much from the light of the sun and that of a lamp in regard to the streaks of the spectrum. "This experiment may also be made, though in an imperfect manner, by viewing a narrow slit between two nearly closed window-shutters through a very excellent glass prism, held close to the eye, with the refracting angle parallel to the line of light. When the spectrum is formed by the sun's rays, either direct or indirect, as from the sky, clouds, rainbow, moon, or planets, the black bands are always found to be in the same parts of the spectrum, and under all circumstances to maintain the same relative position, breadth, and intensities."

From what has been stated in reference to the solar spectrum, it will evidently appear that white light is nothing else than a compound of all the prismatic colors; and this may be still further illustrated by showing that the seven primary colors, when again put together, recompose white light. This may be rudely proved, for the purpose of illustration, by mixing together seven different powders, having the colors and proportion of the spectrum; but the best mode, on the whole, is the following: Let two circles be drawn on a smooth round board, covered with white paper, as in figure 34; let the outermost be divided into 360

Fig. 34.

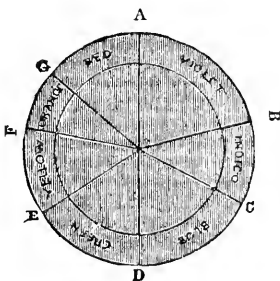

equal parts; then draw seven right lines, as *A*, *B*, *C*, &c., from the center to the outermost circle, making the lines *A* and *B* include 80 degrees of that circle. The lines *B* and *C*, 40 degrees; *C* and *D*, 60; *D* and *E*, 60; *E* and *F*, 48; *F* and *G*, 27; *G* and *A*, 45. Then between these two circles paint the space *A G* red, inclining to orange near *G*; *G F* orange, inclining to yellow near *F*; *F E* yellow, inclining to green near *E*; *E D* green, inclining to blue near *D*; *D C* blue, inclining to

indigo near *C*; *C B* indigo, inclining to violet near *B*; and *B A* violet, inclining to a soft red near *A*. This done, paint all that part of the board black which lies within the inner circle; and, putting an axis through the center of the board, let it be turned swiftly round that axis, so that the rays proceeding from the above colors may be blended and mixed together in coming to the eye. Then the whole colored part will appear like a white ring a little grayish—not perfectly white, because no art can prepare or lay on perfect colors, in all their delicate shades, as found in the real spectrum.

That all the colors of light, when blended together in their proper proportions, produce a pure white, is rendered certain by the following experiment: Take a large convex glass, and place it in the room of the paper or screen on which the solar spectrum was depicted (L. M. fig. 31); the glass will unite all the rays that come from the prism, if a paper is placed to receive them, and you will see a circular spot of pure lively white. The rays will cross each other in the focus of the glass, and, if the paper be removed a little farther from that point, you will see the prismatic colors again displayed, but in an inverted order, owing to the crossing of the rays.

## SECTION II.

## ON THE COLORS OF NATURAL OBJECTS.

FROM what has been stated above we may learn the true cause of those diversified hues exhibited by natural and artificial objects, and the variegated coloring which appears on the face of nature. It is owing to the surfaces of bodies being disposed to reflect one color rather than another. When this disposition is such that the body reflects every kind of ray, in the mixed state in which it receives them, that body appears white to us, which, properly speaking, is no color, but rather the assemblage of all colors. If the body has a fitness to reflect one sort of rays more abundantly than others, by absorbing all the others, it will appear of the color belonging to that species of rays. Thus, the grass is green, because it absorbs all the rays, except the green. It is these green rays only, which the grass, the trees, the shrubs, and all the other verdant parts of the landscape reflect to our sight, and which make them appear green. In the same manner, the different flowers reflect their respective colors; the rose, the red rays; the violet, the blue; the jonquil, the yellow; the marigold, the orange; and every object, whether natural or artificial, appears of that color which its peculiar texture is fitted to reflect. A great number of bodies are fitted to reflect at once several kinds of rays, and of consequence, they appear under mixed colors. It may even happen that of two bodies which should be green, for example, one may reflect the pure green of light, and the other, the mixture of yellow and blue. This quality, which varies to infinity, occasions the different kinds of rays to unite in every possible manner, and every possible proportion; and hence the inexhaustible variety of shades and hues which nature has diffused over the landscape of the world. When a body absorbs nearly all the light which reaches it, that body appears black; it transmits to the eye so few reflected rays that it is scarcely perceptible in itself, and its presence and form make no impression upon us unless as it interrupts the brightness

of the surrounding space. Black is, therefore, the absence of all the colored rays.

It is evident, then, that all the various assemblages of colors which we see in the objects around us *are not in the bodies themselves*, but in the light which falls upon them. There is no color *inherent* in the grass, the trees, the fruits, and the flowers, nor even in the most splendid and variegated dress that adorns a lady. All such objects are as destitute of color, in themselves, as bodies which are placed in the center of the earth, or as the chaotic materials out of which our globe was formed before light was created; for, where there is no light, there is no color. Every object is black, or without color, in the dark, and it only appears colored as soon as light renders it visible. This is further evident from the following experiment: If we place a colored body in one of the colors of the spectrum which is formed by the prism, it appears of the color of the rays in which it is placed. Take, for example, a red rose, and expose it first to the red rays, and it will appear of a more brilliant ruddy hue; hold it in the blue rays, and it appears no longer red, but of a dingy blue color, and in like manner its color will appear different when placed in all the other differently-colored rays. This is the reason why the colors of objects are essentially altered by the nature of the light in which they are seen. The colors of ribbons, and various pieces of silk or woollen stuff, are not the same when viewed by candlelight as in the day-time. In the light of a candle or a lamp, blue often appears green, and yellow objects assume a whitish aspect. The reason is, that the light of a candle is not so pure a white as that of the sun, but has a yellowish tinge, and therefore, when refracted by the prism, the yellowish rays are found to predominate, and the superabundance of yellow rays gives to blue objects a greenish hue.

The doctrine we are now illustrating is one which a great many persons, especially among the fair sex, find it difficult to admit. They cannot conceive it possible that there is no color really inherent in their splendid attire, and no tints of beauty in their countenances. "What," said a certain lady, "are there no colors in my shawl, and in the ribbons that adorn my headdress, and are we all as black as negroes in the dark? I should almost shudder to think of it." Such persons, however, need be in no alarm at the idea, but may console themselves with the reflection that, when they are stripped of all their colored ornaments in the dark, they are certain that *they will never be seen by any one* in that state; and therefore there is no reason to regret the temporary loss of those beauties which light creates, when they themselves, and all surrounding objects, are *invisible*. But, to give a still more palpable proof of this position, the following popular experiments may be stated:

Take a pint of common spirit and pour it into a soup dish, and then set it on fire; as it begins to blaze, throw a handful of salt into the burning spirit, and keep stirring it with a spoon. Several handfuls may thus be successively thrown in, and then the spectators, standing around the flame, will see each other frightfully changed, their colors being altered into a ghastly blackness, in consequence of the nature of the light which falls upon them, which produces colors very different from those of the solar light. The following experiment, as described by Sir D. Brewster, illustrates the same principle: "Having obtained the means of illuminating any apartment with *yellow* light, let the exhibition be made in a room with furniture of various bright colors, and with oil

or water-colored paintings on the wall. The party which is to witness the experiment should be dressed in a diversity of the gayest colors, and the brightest colored flowers and highly colored drawings should be placed on the tables. The room, being at first lighted with ordinary lights, the bright and gay colors of everything that it contains will be finely displayed. If the white lights are now suddenly extinguished, and the yellow lamps lighted, the most appalling metamorphosis will be exhibited. The astonished individuals will no longer be able to recognize each other. All the furniture of the room, and all the objects it contains, will exhibit only *one* color. The flowers will lose their hues; the paintings and drawings will appear as if they were executed in China ink, and the gayest dresses, the brightest scarlets, the purest lilacs, the richest blues, and the most vivid greens, will all be converted into one monotonous yellow. The complexions of the parties, too, will suffer a corresponding change. One pallid death-like yellow,

Like the unnatural hue  
Which autumn paints upon the perished leaf,

will envelop the young and the old, and the *sal-low* face will alone escape from the metamorphosis. Each individual derives merriment from the cadaverous appearance of his neighbor, without being sensible that he is one of the ghastly assemblage."

From such experiments as these we might conclude that, were the solar rays of a very different description from what they are now found to be, the colors which embellish the face of nature, and the whole scene of our sublunary creation, would assume a new aspect, and appear very different from what we now behold around us in every landscape. We find that the stars display great diversity of color, which is doubtless owing to the different kinds of light which are emitted from those bodies; and hence we may conclude that the coloring thrown upon the various objects of the universe is different in every different system, and that thus, along with other arrangements, an infinite variety of coloring and of scenery is distributed throughout the immensity of creation.

The *atmosphere*, in consequence of its different refractive and reflective powers, is the source of a variety of colors which frequently embellish and diversify the aspect of our sky. The air *reflects* the blue rays most plentifully, and must therefore *transmit* the red, orange, and yellow more copiously than the other rays. When the sun and other heavenly bodies are at a high elevation, their light is transmitted without any perceptible change; but when they are near the horizon, their light must pass through a long and dense track of air, and must therefore be considerably modified before it reach the eye of the observer. The momentum of the red rays being greater than that of the violet, will force their way through the resisting medium, while the violet rays will be either reflected or absorbed. If the light of the setting sun, by thus passing through a long track of air, be divested of the green, blue, indigo, and violet rays, the remaining rays which are transmitted through the atmosphere will illuminate the western clouds, first, with an orange color, and then, as the sun gradually sinks into the horizon, the track through which the rays must pass becoming longer, the yellow and orange are reflected, and the clouds grow more deeply *red*, until at length the disappearance of the sun leaves them of a leaden hue, by the reflection of the blue light through the air. Similar changes of

color are sometimes seen on the eastern and western fronts of white buildings. St. Paul's Church, in London, is frequently seen, at sunset, tinged with a very considerable degree of redness, and the same cause occasions the moon to assume a ruddy color, by the light transmitted through the atmosphere. From such atmospherical refractions and reflections are produced those rich and beautiful hues with which our sky is gilded by the setting sun, and the glowing red which tinges the morning and evening clouds, until their ruddy glare is tempered by the purple of twilight, and the reflected azure of the sky.

When a direct spectrum is thrown on colors darker than itself, it mixes with them, as the yellow spectrum of the setting sun, thrown on the green grass, becomes a greener yellow. But when a direct spectrum is thrown on colors brighter than itself, it becomes instantly changed into the reverse spectrum, which mixes with those brighter colors. Thus the yellow spectrum of the setting sun, thrown on the luminous sky, becomes blue, and changes with the color or brightness of the clouds on which it appears. The red part of light being capable of struggling through thick and resisting mediums which intercept all other colors, is likewise the cause why the sun appears red when seen through a fog; why distant light, though transmitted through blue or green glass, appears red; why lamps at a distance, seen through the smoke of a long street, are red, while those that are near are white. To the same cause it is owing that a diver at the bottom of the sea is surrounded with the red light which has pierced through the superincumbent fluid, and that the blue rays are reflected from the surface of the ocean. Hence Dr. Halley informs us that, when he was in a diving-bell at the bottom of the sea, his hand always appeared red in the water.

The blue rays, as already noticed, being unable to resist the obstructions they meet with in their course through the atmosphere, are either reflected or absorbed in their passage. It is to this cause that most philosophers ascribe the blue color of the sky, the faintness and obscurity of distant objects, and the bright azure which tinges the mountains of a distant landscape.

### SECTION III.

#### PHENOMENA OF THE RAINBOW.

SINCE the rays of light are found to be decomposed by refracting surfaces, and reflected in an infinite variety of modes and shades of color, we need not be surprised at the changes produced in any scene or object by the intervention of another, and by the numerous modifications of which the primary colors of nature are susceptible. The vivid colors which gild the rising and the setting sun must necessarily differ from those which adorn its noonday splendor. Variety of atmospheric scenery will thus necessarily be produced, greater than the most lively fancy can well imagine. The clouds will sometimes assume the most fantastic forms, and at other times will be irradiated with beams of light, or, covered with the darkest hues, will assume a lowering aspect, prognostic of the thunder's roar and the lightning's flash, all in accordance with the different rays that are reflected to our eyes, or the quantity absorbed by the vapors which float in the atmosphere.

Light, which embellishes with so much magnificence a pure and serene sky, by means of innumerable bright starry orbs which are spread over it, sometimes, in a dark and cloudy sky, exhibits an ornament which, by its pomp, splendor, and variety of colors, attracts the attention of every eye that has an opportunity of beholding it. At certain times, when there is a shower either around us, or at a distance from us in an opposite quarter to that of the sun, a species of arch or bow is seen in the sky, adorned with all the seven primary colors of light. This phenomenon, which is one of the most beautiful meteors in nature, has obtained the name of the RAINBOW. The rainbow was, for ages, considered as an inexplicable mystery, and by some nations it was adored as a deity. Even after the dawn of true philosophy, it was a considerable time before any discovery of importance was made as to the true causes which operate in the production of this phenomenon. About the year 1571, M. Fletcher, of Breslau, made a certain approximation to the discovery of the true cause, by endeavoring to account for the colors of the rainbow by means of a double refraction and one reflection. A nearer approximation was made by Antonio de Dominis, bishop of Spalatro, about 1601. He maintained that the double refraction of Fletcher, with an intervening reflection, was sufficient to produce the colors of the bow, and also to bring the rays that formed them to the eye of the spectator, without any subsequent reflection. To verify this hypothesis, he procured a small globe of solid glass, and viewing it when it was exposed to the rays of the sun, with his back to that luminary, in the same manner as he had supposed the drops of rain were situated with respect to them, he observed the same colors which he had seen in the rainbow, and in the same order. But he could give no good reason why the bow should be colored, and, much less, any satisfactory account of the order in which the colors appear. It was not until Sir I. Newton discovered the different refrangibility of the rays of light that a complete and satisfactory explanation could be given of all the circumstances connected with this phenomenon.

As the full elucidation of this subject involves a variety of optical and mathematical investigations, I shall do little more than explain the general principle on which the prominent phenomena of the rainbow may be accounted for, and some of the facts and results which theory and observation have deduced.

We have just now alluded to an experiment with a glass globe: If, then, we take either a solid glass globe, or a hollow globe filled with water, and suspend it so high in the solar rays above the eye that the spectator, with his back to the sun, can see the globe red; if it be lowered slowly, he will see it orange, then yellow, then green, then blue, then indigo, and then violet; so that the drop, at different heights, shall present to the eye the seven primitive colors in succession. In this case, the globe, from its form, will act in some measure like a prism, and the ray will be separated into its component parts. The following figure will more particularly illustrate this point. Suppose *A* (fig. 35) to represent a drop of rain—which may be considered as a globe of glass in miniature, and will produce the same effect on the rays of light—and let *S* *D* represent a ray from the sun falling upon the upper part of the drop at *D*. At the point of entering the drop it will suffer a refraction, and, instead of going forward to *c*, it will be bent to *n*. From *n* a part of the light will be reflected to *q*—some part of it will, of course pass through the drop. By the obliquity with which it falls on the side of the

drop at *q*, that part becomes a kind of prism, and separates the ray into its primitive colors. It is

Fig. 35.

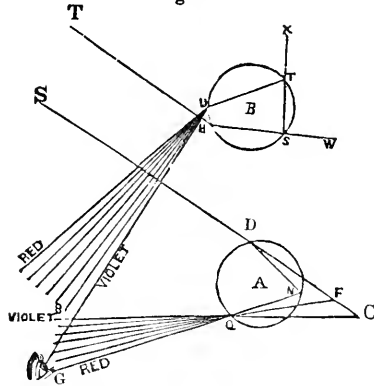

found by computation, that after a ray has suffered two refractions and one reflection, as here represented, the least refrangible part of it, namely, the red ray, will make an angle with the incident solar ray of  $42^{\circ} 2'$ , as *S F a*; and the violet, or greatest refrangible ray, will make, with the solar ray, an angle of  $40^{\circ} 17'$ , as *S c a*; and thus all the particles of water within the difference of those two angles, namely,  $1^{\circ} 45'$  (supposing the ray to proceed merely from the center of the sun), will exhibit severally the colors of the prism, and constitute the interior bow of the cloud. This holds good at whatever height the sun may chance to be in a shower of rain. If he be at a high altitude, the rainbow will be low; if he be at a low elevation, the rainbow must be high; and if a shower happen in a vale, when the spectator is on a mountain, he will sometimes see the bow in the form of a complete circle below him. We have at present described the phenomena only of a single drop; but it is to be considered that in a shower of rain there are drops at all heights and at all distances, and therefore the eye situated at *g* will see all the different colors. All those drops that are in a certain position with respect to the spectator will reflect the red rays, all those in the next station the orange, those in the next the green, and so on with regard to all the other colors.

It appears, then, that the first or primary bow is formed by two refractions and one reflection; but there is frequently a second bow on the outside of the other, which is considerably fainter. This is produced by drops of rain above the drop we have supposed at *A*. If *B* (fig. 35) represent one of these drops, the ray to be sent to the eye enters the drop near the bottom, and suffers two refractions and two reflections, by which means the colors become reversed, that is, the violet is lowest in the exterior bow, and the red is lowest in the interior one, and the other colors are reversed accordingly. The ray *T* is refracted at *r*: a part of it is reflected from *s* to *t*, and at *t* it suffers another reflection from *t* to *u*. At the points *s* and *t* part of the ray passes through the drop, on account of its transparency, toward *w* and *x*, and therefore we say that part only of the ray is reflected. By these losses and reflections the exterior bow becomes faint and ill-defined in comparison of the interior or primary bow. In this case the upper part of the secondary bow will not be seen when the sun is above  $54^{\circ} 10'$  above the horizon, and the lower part of the bow will not be seen when the sun is  $60^{\circ} 58'$  above the horizon.

For the further illustrations of this subject, we

may introduce the following section of a bow (fig. 36), and, in order to prevent confusion in at-

Fig. 36.

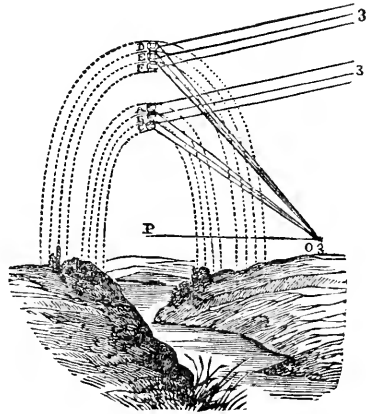

tempting to represent all the different colors, let us suppose only three drops of rain, and three different colors, as shown in the figure. The spectator, *O*, being in the center of the two bows here represented—the planes of which must be considered as perpendicular to his view—the drops *A*, *B*, and *C* produce part of the interior bow by two refractions and one reflection, as stated before, and the drops *D*, *E*, *F* will produce the exterior bow by two refractions and two reflections, the sun's rays being represented by 3, 3. It is evident that the angle *C O P* is less than the angle *B O P*, and that the angle *A O P* is the greatest of the three. The largest angle, then, is formed by the red rays, the middle one consists of the green, and the smallest the purple or violet. All the drops of rain, therefore, that happen to be in a certain position with respect to the spectator's eye, will reflect the red rays, and form a band or semicircle of red, and so of the other colors from drops in other positions. If the spectator alters his station, he will see a bow, but not the same as before; and if there be many spectators, they will each see a different bow, though it appears to be the same.

The rainbow assumes a semicircular appearance, because it is only at certain angles that the refracted rays are visible to our eyes, as is evident from the experiment of the glass globe formerly alluded to, which will refract the rays only in a certain position. We have already stated that the red rays make an angle of  $42^{\circ} 2'$ , and the violet an angle of  $40^{\circ} 17'$ . Now, if a line be drawn horizontally from the spectator's eye, it is evident that angles formed with this line, of a certain dimension, in every direction, will produce a circle, as will appear by attaching a cord of a given length to a certain point, round which it may turn as round its axis; and, in every point, will describe an angle with the horizontal line of a certain and determinate extent.

Sometimes it happens that three or more bows are visible, though with different degrees of distinctness. I have more than once observed this phenomenon, particularly in Edinburgh, in the month of August, 1825, when three rainbows were distinctly seen in the same quarter of the sky, and, if I recollect right, a fragment of the fourth made its appearance. This happens when the rays suffer a third or fourth reflection; but on account of the light lost by so many reflections,

such bows are, for the most part, altogether imperceptible.

If there were no ground to intercept the rain and the view of the observer, the rainbow would form a *complete circle*, the center of which is diametrically opposite to the sun. Such circles are sometimes seen in the spray of the sea or of a cascade, or from the tops of lofty mountains, when the showers happen in the vales below.—Rainbows of various descriptions are frequently observed rising amid the spray and exhalations of waterfalls, and among the waves of the sea, whose tops are blown by the wind into small drops.—There is one regularly seen when the sun is shining, and the spectator in a proper position, at the fall of Staubbach, in the bosom of the Alps; one near Schaffhausen; one at the cascade of Lauffen, and one at the cataract of Niagara in North America. A still more beautiful one is said to be seen at Terni, where the whole current of the River Velino, rushing from a steep precipice of nearly 200 feet high, presents to the spectator below a variegated circle, overarching the fall, and two other bows suddenly reflected on the right and left. Don Ulloa, in the account of his journeys in South America, relates that circular rainbows are frequently seen on the mountains above Quito in Peru. It is said that a rainbow was once seen near London, caused by the exhalations of that city, after the sun had been below the horizon more than twenty minutes.\* A naval friend, says Mr. Bucke, informed me that, as he was one day watching the sun's effect upon the exhalations near Juan Fernandez, he saw upward of five-and-twenty *ires marines* animate the sea at the same time. In these marine bows the concave sides were turned upward, the drops of water rising from below, and not falling from above, as in the instances of the aerial arches.—Rainbows are also occasionally seen on the grass in the morning dew, and likewise when the hoarfrost is descending. Dr. Langwith once saw a bow lying on the ground, the colors of which were almost as lively as those of a common rainbow. It was not round, but oblong, and was extended several hundred yards. The colors took up less space, and were much more lively in those parts of the bow which were near him than in those which were at a distance. When M. Labillardiere was on Mount Teneriffe, he saw the contour of his body traced on the clouds beneath him in all the colors of the solar bow. He had previously witnessed this phenomenon on the Kesrouan, in Asia Minor. The rainbows of Greenland are said to be frequently of a pale white, fringed with a brownish yellow arising from the rays of the sun being reflected from a frozen cloud.

The following is a summary view of the principal facts which have been ascertained respecting the rainbow: 1. The rainbow can only be seen when it rains, and in that point of the heavens which is opposite to the sun. 2. Both the primary and secondary bows are variegated with all the prismatic colors—the red being the highest color in the primary, or brightest bow, and the violet the highest in the exterior. 3. The primary rainbow can never be a greater arc than a semicircle; and, when the sun is set, no bow, in ordinary circumstances, can be seen. 4. The breadth of the inner or primary bow—supposing the sun but a point—is  $1^{\circ} 45'$ , and the breadth of the exterior bow  $3^{\circ} 12'$ , which is nearly twice as great as that of the other; and the distance between the

bows is  $8^{\circ} 55'$ . But since the body of the sun subtends an angle of about half a degree, by so much will each bow be increased, and their distance diminished; and therefore the breadth of the interior bow will be  $2^{\circ} 15'$ , and that of the exterior  $3^{\circ} 42'$ , and their distance  $8^{\circ} 25'$ . The greatest semidiameter of the interior bow, on the same grounds, will be  $42^{\circ} 17'$ , and the least of the exterior bow  $50^{\circ} 43'$ . 5. When the sun is in the horizon, either in the morning or evening, the bows will appear complete semicircles. On the other hand, when the sun's altitude is equal to  $42^{\circ} 2'$ , or to  $54^{\circ} 10'$ , the summits of the bows will be depressed below the horizon. Hence, during the days of summer, within a certain interval each day, no visible rainbows can be formed, on account of the sun's high altitude above the horizon. 6. The altitude of the bows above the horizon or surface of the earth varies according to the elevation of the sun. The altitude, at any time, may be taken by a common quadrant, or any other angular instrument; but if the sun's altitude at any particular time be known, the height of the summit of any of the bows may be found by subtracting the sun's altitude from  $42^{\circ} 2'$  for the inner bow, and from  $54^{\circ} 10'$  for the outer. Thus, if the sun's altitude be  $26^{\circ}$ , the height of the primary bow would be  $16^{\circ} 2'$ , and of the secondary,  $28^{\circ} 10'$ . It follows that the height and the size of the bows diminish as the altitude of the sun increases. 7. If the sun's altitude is more than  $42^{\circ}$ , and less than  $54^{\circ}$ , the exterior bow may be seen, though the interior bow is invisible. 8. Sometimes only a portion of an arch will be visible, while all the other parts of the bow are invisible. This happens when the rain does not occupy a space of sufficient extent to complete the bow; and the appearance of this position, and even of the bow itself, will be various, according to the nature of the situation, and the space occupied by the rain.

The appearance of the rainbow may be produced by artificial means at any time, when the sun is shining, and not too highly elevated above the horizon. This is effected by means of artificial fountains, or *jet d'eau*s, which are intended to throw up streams of water to a great height. These streams, when they spread very wide, and blend together in their upper parts, form, when falling, a shower of artificial rain.—If, then, when the fountain is playing, we move between it and the sun, at a proper distance from the fountain, until our shadow point directly toward it, and look at the shower, we shall observe the colors of the rainbow strong and vivid; and, what is particularly worthy of notice, the bow appears, notwithstanding the nearness of the shower, to be as large and as far off as the rainbow which we see in a natural shower of rain. The same experiment may be made by candle-light, and with any instrument that will form an artificial shower.

*Lunar Rainbows.*—A lunar bow is sometimes formed at night, by the rays of the moon striking on a rain-cloud, especially when she is about the full. But such a phenomenon is very rare. Aristotle is said to have considered himself the first who had seen a lunar rainbow. For more than a hundred years prior to the middle of the last century, we find only two or three instances recorded in which such phenomena are described with accuracy. In the Philosophical Transactions for 1783, however, we have an account of three having been seen in one year, and all in the same place, but they are by no means common phenomena. I have had an opportunity within the last

\* Philosophical Transactions, vol. 1, p. 294.



twenty years of witnessing two phenomena of this description, one of which was seen at Perth, on a Sabbath evening, in the autumn of 1825, and the other at Edinburgh, on Wednesday, the 9th of September, 1840, about eight o'clock in the evening, of both which I gave a detailed description in some of the public journals. The moon, in both cases, was within a day or two of the full; the arches were seen in the northern quarter of the heavens, and extended nearly from east to west, the moon being not far from the southern meridian. The bows appeared distinct and well defined, but no distinct traces of the prismatic colors could be perceived on any of them. That which appeared in 1825 was the most distinctly formed, and continued visible for more than an hour. The other was much fainter, and lasted little more than half an hour, dark clouds having obscured the face of the moon.—These bows bore a certain resemblance to some of the luminous arches which sometimes accompany the Aurora Borealis, and this latter phenomenon has not unfrequently been mistaken for a lunar rainbow; but they may be always distinguished by attending to the phases and position of the moon. If the moon be not visible above the horizon, if she be in her first or last quarter, or if any observed phenomenon be not in a direction opposite to the moon, we may conclude with certainty that, whatever appearance is presented, there is no lunar rainbow.

The rainbow is an object which has engaged universal attention, and its beautiful colors and form have excited universal admiration. The poets have embellished their writings with many beautiful allusions to this splendid meteor; and the playful schoolboy, while viewing the "bright enchantment," has frequently run "to catch the falling glory." When its arch rests on the opposite sides of a narrow valley, or on the summits of two adjacent mountains, its appearance is both beautiful and grand. In all probability, its figure first suggested the idea of *arches*, which are now found of so much utility in forming aqueducts and bridges, and for adorning the architecture of palaces and temples. It is scarcely possible seriously to contemplate this splendid phenomenon without feeling admiration and gratitude toward that wise and beneficent Being whose hands have bent it into so graceful and majestic a form, and decked it with all the pride of colors. "Look upon the rainbow," says the son of Sirach,\* "and praise Him that made it: very beautiful it is in the brightness thereof. It compasseth the heaven about with a glorious circle, and the hands of the Most High have bended it." To this grand ethereal bow the inspired writers frequently allude as one of the emblems of the majesty and splendor of the Almighty. In the prophecies of Ezekiel, the throne of Deity is represented as adorned with a brightness "like the appearance of the bow that is in the cloud in the day of rain—the appearance of the likeness of the glory of Jehovah." And, in the visions recorded in the Book of the Revelations, where the Most High is represented as sitting upon a throne, "there was a rainbow round about the throne, in sight like unto an emerald," as an emblem of his propitious character, and of his faithfulness and mercy. After the deluge, this bow was appointed as a sign and memorial of the covenant which God made with Noah and his sons, that a flood of waters should never again be permitted to deluge the earth and its inhabitants, and as a pledge of inviolable fidelity and

Divine benignity. When, therefore, we at any time behold "the bow in the cloud," we have not only a beautiful and sublime phenomenon presented to the eye of sense, but also a memorial exhibited to the mental eye, assuring us that, "While the earth remaineth, seed-time and harvest, and cold and heat, and summer and winter, and day and night, *shall not cease.*"\*

"On the broad sky is seen  
A dewy cloud, and in the cloud a bow  
Conspicuous, with seven listed colors gay,  
Betokening peace with God and covenant new.  
He gives a promise never to destroy  
The earth again by flood, nor let the sea  
Surpass his bounds, nor rain to drown the world."  
MILTON, *Par. Lost*, Book XI.

## SECTION IV.

### REFLECTIONS ON THE BEAUTY AND UTILITY OF COLORS.

COLOR is one of the properties of light which constitutes chiefly the beauty and sublimity of the universe. It is color, in all its diversified shades, which presents to our view that almost infinite variety of aspect which appears on the scene of nature, which gives delight to the eye and the imagination, and which adds a fresh pleasure to every new landscape we behold. Every flower which decks our fields and gardens is compounded of different hues: every plain is covered with shrubs and trees of different degrees of verdure; and almost every mountain is clothed with herbs and grass of different shade from those which appear on the hills and landscape with which it is surrounded. In the country, during summer, nature is every day, and almost every hour, varying her appearance by the multitude and variety of her hues and decorations, so that the eye wanders with pleasure over objects continually diversified, and extending as far as the sight can reach. In the flowers with which every landscape is adorned, what a lovely assemblage of colors, and what a wonderful art in the disposition of their shades! Here a light pencil seems to have laid on the delicate tints; there they are blended according to the nicest rules of art. Although green is the general color which prevails over the scene of sublunary nature, yet it is diversified by a thousand different shades, so that every species of tree, shrub, and herb is

\* It is a question which has been frequently started, whether there was any rainbow before the flood? Some have conceived that the rainbow was something of a *miraculous* production, and that it was never seen before the flood. The equivocal sense of the word "set," in our translation, has occasioned a mistaken impression of this kind. The Hebrew word, thus translated, signifies more properly "I do give," or "I appoint." The whole passage in reference to this circumstance, literally translated, runs thus: "I appoint my bow which is in the cloud, that it may be for a sign or token of a covenant between me and the earth; and it shall come to pass, when I bring a cloud over the earth, and the bow shall be seen in the cloud, that I will remember my covenant that is between me and you," &c. As the rainbow is produced by the immutable laws of refraction and reflection, as applied to the rays of the sun striking on drops of falling rain, the phenomenon must have been occasionally exhibited from the beginning of the world; unless we suppose that there was no rain before the flood, and that the constitution of things in the physical system was very different from what it is now. The passage affirms no more than that the rainbow was *then appointed* to be a *symbol* of the covenant between God and man; and although it may have been frequently seen before, it would serve the purpose of a sign equally well as if it had been miraculously formed for this purpose, and even better, as its frequent appearance, according to natural laws, is a perpetual memorial to man of the Divine faithfulness and mercy.

\* Ecclesiasticus, xliiii, 11, 12.

clothed with its own peculiar verdure. The dark green of the forests is thus easily distinguished from the lighter shades of cornfields and the verdure of the lawns. The system of animated nature likewise displays a diversified assemblage of beautiful colors. The plumage of birds, the brilliant feathers of the peacock, the ruby and emerald hues which adorn the little humming-bird, and the various embellishments of many species of the insect tribe, present to the eye in every region of the globe, a scene of diversified beauty and embellishment. Nor is the mineral kingdom destitute of such embellishments; for some of the darkest and most unshapely stones and pebbles, when polished by the hand of art, display a mixture of the most delicate and variegated colors. All which beauties and varieties in the scene around us are entirely owing to that property, in every ray of light, by which it is capable of being separated into the primitive colors.

To the same cause, likewise, are to be ascribed those beautiful and diversified appearances which frequently adorn the face of the sky—the yellow, orange, and ruby hues which embellish the firmament at the rising of the sun, and when he is about to descend below the western horizon; and those aerial landscapes, so frequently beheld in tropical climes, where rivers, castles, and mountains are depicted rolling over each other along the circle of the horizon. The clouds, especially in some countries, reflect almost every color in nature. Sometimes they wear the modest blush of the rose; sometimes they appear like stripes of deep vermilion, and sometimes as large, brilliant masses tinged with various hues; now they are white as ivory, and now as yellow as native gold. In some tropical countries, according to St. Pierre, the clouds roll themselves up into enormous masses as white as snow, and are piled upon each other, like the Cordilleras of Peru, and are molded into the shape of mountains, of caverns, and of rocks. When the sun sets behind this magnificent aerial network, a multitude of luminous rays are transmitted through each particular interstice, which produce such an effect that the two sides of the lozenge illuminated by them have the appearance of being begirt with a fillet of gold; and the other two, which are in the shade, seem tinged with a superb ruddy orange. Four or five divergent streams of light, emanating from the setting sun up to the zenith, clothe with fringes of gold the undeterminate summits of this celestial barrier, and proceed to strike with the reflexes of their fires the pyramids of the collateral aerial mountains, which then appear to consist of silver and vermilion. In short, color diversifies every sublunary scene, whether on the earth or in the atmosphere; it imparts a beauty to the phenomena of falling stars, of luminous arches, and the coruscations of the Aurora Borealis, and gives a splendor and sublimity to the spacious vault of heaven.

Let us now consider for a moment what would be the aspect of nature if, instead of the beautiful variety of embellishments which now appear on every landscape, and on the concave of the sky, *one* uniform color had been thrown over the scenery of the universe. Let us conceive the whole of terrestrial nature to be covered with snow, so that not an object on earth should appear with any other hue, and that the vast expanse of the firmament presented precisely the same uniform aspect. What would be the consequence? The light of the sun would be strongly reflected from all the objects within the bounds of our horizon, and would produce a luster which would dazzle every eye. The day would acquire a greater

*brightness* than it now exhibits, and our eyes might, after some time, be enabled freely to expatiate over the surrounding landscape; but everything, though enlightened, would appear *confused*, and particular objects would scarcely be distinguishable. A tree, a house, or a church near at hand might possibly be distinguished, on account of its elevation above the general surface of the ground, and the bed of a river by reason of its being depressed below it. But we should be obliged rather to guess, and to form a conjecture as to the particular object we wished to distinguish, than to arrive at any certain conclusion respecting it; and if it lay at a considerable distance, it would be impossible, with any degree of probability, to discriminate any one object from another. Notwithstanding the universal brightness of the scene, the uniformity of color thrown on every object would most certainly prevent us from distinguishing a church from a palace, a cottage from a knoll or heap of rubbish, a splendid mansion from rugged rocks, the trees from the hills on which they grow, or a barren desert from rich and fertile plains. In such a case human beings would be confounded, and even friends and neighbors be at a loss to recognize one another.

The vault of heaven, too, would wear a uniform aspect. Neither planets nor comets would be visible to any eye, nor those millions of stars which now shine forth with so much brilliancy, and diversify the nocturnal sky; for it is by the contrast produced by the deep azure of the heavens and the white radiance of the stars that those bodies are rendered visible. Were they depicted on a pure white ground they would not be distinguished from that ground, and would, consequently, be invisible, unless any of them occasionally assumed a different color. Of course, all that beautiful variety of aspect which now appears on the face of sublunary nature—the rich verdure of the fields, the stately port of the forest, the rivers meandering through the valleys, the splendid hues that diversify and adorn our gardens and meadows, the gay coloring of the morning and evening clouds, and all that variety which distinguishes the different seasons, would entirely disappear. A every landscape would exhibit nearly the same aspect, there would be no inducement to the poet and the philosopher to visit distant countries to investigate the scenes of nature, and journeyings from one region to another would scarcely be productive of enjoyment. Were any other single color to prevail, nearly the same results would ensue. Were a deep ruddy hue to be uniformly spread over the scene of creation, it would not only be offensive to the eye, but would likewise prevent all distinction of objects. Were a dark blue or a deep violet to prevail, it would produce a similar effect, and, at the same time, present the scene of nature as covered with a dismal gloom. Even if creation were arrayed in a robe of *green* which is a more pleasant color to the eye, were it not diversified with the different shades it now exhibits, every object would be equally undistinguishable.

Such would have been the aspect of creation, and the inconveniences to which we should have been subjected, had the Creator afforded us light without that intermixture of colors which now appears over all nature, and which serves to discriminate one object from another. Even our very apartments would have been tame and insipid, incapable of the least degree of ornament, and the articles with which they are furnished almost undistinguishable, so that, in discriminating one object from another, we should have been as much

indebted to the sense of touch as to the sense of vision. Our friends and fellow-men would have presented no objects of interest in our daily associations. The sparkling eye, the benignant smile, the modest blush, the blended hues of white and vermilion in the human face, and the beauty of the female countenance, would all have vanished, and we should have appeared to one another as so many moving marble statues, cast nearly in the same mold. But what would have been worst of all, the numerous delays, uncertainties, and perplexities to which we should have been subjected, had we been under the necessity every moment of distinguishing objects by trains of reasoning, and by circumstances of time, place, and relative position? An artist, when commencing his work in the morning, with a hundred tools of nearly the same size and shape around him, would have spent a considerable portion of his time before he could have selected those proper for his purpose, or the objects to which they were to be applied; and in every department of society, and in all our excursions from one place to another, similar difficulties and perplexities would have occurred. The one-half of our time must thus have been employed in uncertain guesses and perplexing reasonings respecting the real nature and individuality of objects, rather than in a regular train of thinking and of employment; and, after all our perplexities and conjectures, we must have remained in the utmost uncertainty as to the thousands of scenes and objects which are now obvious to us, through the instrumentality of colors, as soon as we open our eyes.

In short, without color we could have had no books nor writings: we could neither have corresponded with our friends by letters, nor have known anything with certainty of the events which happened in former ages. No written revelation of the will of God, and of his character, such as we now enjoy, could have been handed down to us from remote periods and generations. The discoveries of science and the improvements of art would have remained unrecorded. Universal ignorance would have prevailed throughout the world, and the human mind have remained in a state of demoralization and debasement. All these, and many other inconveniences and evils would have inevitably followed, had not God painted the rays of light with a diversity of colors. And hence we may learn that the most important scenes and events in the universe may depend upon the existence of a single principle in nature, and even upon the most minute circumstances, which we may be apt to overlook, in the arrangements of the material world.

In the existing state of things in the visible creation, we cannot but admire the wisdom and beneficence of the Deity in thus enabling us to distinguish objects by so easy and expeditious a mode as *that of color*, which in a moment discriminates every object and its several relations. We rise in the morning to our respective employments, and our food, our drink, our tools, our books, and whatever is requisite for our comfort, are at once discriminated. Without the least hesitation or uncertainty, and without any perplexing process of reasoning, we can lay our hands on whatever articles we require. Color clothes every object with its peculiar livery, and infallibly directs the hand in its movements, and the eye in its surveys and contemplations. But this is not the only end which the Divine Being had in view in impressing on the rays of light a diversity of colors. It is evident that he likewise intended to minister to our *pleasures* as well as to our wants. To every

man of taste, and almost to every human being, the combination of colors in flowers, the delicate tints with which they are painted, the diversified shades of green with which the hills and dales, the mountains and the vales are arrayed, and that beautiful variety which appears in a bright summer day on all the objects of this lower creation, are sources of the purest enjoyment and delight. It is color, too, as well as magnitude, that adds to the *sublimity* of objects. Were the canopy of heaven of one uniform hue, it would fail in producing those lofty conceptions, and those delightful and transporting emotions, which a contemplation of its august scenery is calculated to inspire. Colors are likewise of considerable utility in the intercourse of general society. They serve both for ornaments, and for distinguishing the different ranks and conditions of the community; they add to the beauty and gracefulness of our furniture and clothing. At a glance, they enable us at once to distinguish the noble from the ignoble, the prince from his subjects, the master from his servant, and the widow, clothed with sable weeds, from the bride adorned with her nuptial ornaments.

Since colors, then, are of so much value and importance, they may be reckoned as holding a rank among the noblest natural gifts of the Creator. As they are of such essential service to the inhabitants of our globe, there can be no doubt that they serve similar or analogous purposes throughout all the worlds in the universe. The colors displayed in the solar beams are common to all the globes which compose the planetary system, and must necessarily be reflected, in all their diversified hues, from objects on their surfaces. The light which radiates from the fixed stars displays a similar diversity of colors. Some of the double stars are found to emit light of different hues; the larger star exhibiting light of a ruddy or orange hue, and the smaller one a radiance which approaches to blue or green. There is, therefore, reason to conclude that the objects connected with the planets which revolve round such stars—being occasionally enlightened by suns of different hues—will display a more variegated and splendid scenery of coloring than is ever beheld in the world on which we dwell; and that one of the distinguishing characteristics of different worlds, in regard to their embellishments, may consist in the splendor and variety of colors with which the objects on their surfaces are adorned. In the metaphorical description of the glories of the New Jerusalem, recorded in the Book of Revelation, one of the chief characteristics of that city is said to consist in the splendor and diversity of hues with which it is adorned. It is represented as “coming down from heaven, *prepared as a bride adorned for her husband*,” and as reflecting all the beautiful and variegated colors which the finest gems on earth can exhibit; evidently indicating that splendor and variety of coloring are some of the grandest features of celestial scenery.

On the whole, the subject of colors, when seriously considered, is calculated to excite us to the adoration of the goodness and intelligence of that Almighty Being whose wisdom planned all the arrangements of the universe, and to inspire us with gratitude for the numerous conveniences and pleasures we derive from those properties and laws he has impressed on the material system. He might have afforded us light, and even splendid illumination, without the pleasures and advantages which diversified colors now produce, and man and other animated beings might have existed in such a state. But what a very different

scene would the world have presented from what it now exhibits! Of how many thousands of pleasures should we have been deprived! and to what numerous inconveniences and perplexities should we have been subjected! The sublimity and glories of the firmament, and the endless beauties and varieties which now embellish our terrestrial system, would have been forever unknown, and man could have had little or no incitement to study and investigate the works of his Creator. In this, as well as in many other arrangements in nature, we have a sensible proof of the presence and agency of that Almighty Intelligence "in whom we live, and move, and have our being." None but an infinitely Wise and Beneficent Being, intimately present in all places, could thus so regularly create in us, by means of color, those exquisite sensations which afford so much delight, and which unite us, as it were, with everything around us. In the diversity of

hues spread over the face of creation, we have as real a display of the Divine presence as Moses enjoyed at the burning bush. The only difference is, that the one was out of the common order of Divine procedure, and the other in accordance with those permanent laws which regulate the economy of the universe. In every color, then, which we contemplate, we have a sensible memorial of the presence of that Being "whose Spirit garnished the heavens and laid the foundations of the earth," and whose "merciful visitation" sustains us every moment in existence. But the revelation of God to our senses, through the various objects of the material world, has become so familiar, that we are apt to forget the Author of all our enjoyments, even at the moment when we are investigating his works and participating of his benefits. "O that men would praise Jehovah for his goodness, and for his wonderful works toward the children of men."

---

## PART II.

### ON TELESCOPES.

---

#### CHAPTER I.

##### HISTORY OF THE INVENTION OF TELESCOPES.

THE telescope is an optical instrument for viewing objects at a distance. Its name is compounded of two Greek words, *τηλε*, which signifies *at a distance* or *far off*, and *σκοπειν*, *to view* or *to contemplate*. By means of telescopes, remote objects are represented as if they were near, small apparent magnitudes are enlarged, confused objects are rendered distinct, and the invisible and obscure parts of very distant scenes are rendered perceptible and clear to the organ of vision. The telescope is justly considered as a grand and noble instrument. It is not a little surprising that it should be in the power of man to invent and construct an instrument by which objects, too remote for the unassisted eye to distinguish, should be brought within the range of distinct vision, as if they were only a few yards from our eye, and that thousands of august objects in the heavens, which had been concealed from mortals for numerous ages, should be brought within the limits of our contemplation, and be as distinctly perceived as if we had been transported many millions of miles from the space we occupy through the celestial regions. The celebrated Huygens remarks, in reference to this instrument, that, in his opinion, "the wit and industry of man has not produced anything so noble and so worthy of his faculties as this sort of knowledge (namely, of the telescope); inasmuch that if any particular person had been so diligent and sagacious as to invent this instrument from the principles of nature and geometry, for my part, I should have thought his abilities were more than human; but the case is so far from this, that the most learned men have not yet been able sufficiently to explain the reason of the effects of this casual invention."

The persons who constructed the first telescopes, and the exact period when they were first invented, are involved in some degree of obscurity. It does not certainly appear that such instruments were known to the ancients, although we ought not to be perfectly decisive on this point. The cabinets of the curious contain some very ancient gems of admirable workmanship, the figures on which are so small that they appear beautiful through a magnifying glass, but altogether confused and indistinct to the naked eye; and therefore it may be asked, If they cannot be viewed, how could they be wrought, without the assistance of glasses? And as some of the ancients have declared that the moon has a form like that of the earth, and has plains, hills, and valleys in it, how could they know this, unless by mere conjecture, without the use of a telescope? And how could they have known that the *Milky Way* is formed by the combined rays of an infinite number of stars? For Ovid states, in reference to this zone, "its groundwork is of stars." But, whatever knowledge the ancients may have possessed of the telescope or other optical glasses, it is quite evident that they never had telescopes of such size and power as those which we now possess, and that no discoveries in the heavens, such as are now brought to light, were made by any of the ancient astronomers, otherwise some allusions to them must have been found in their writings.

Among the moderns, the illustrious Friar Bacon appears to have acquired some rude ideas respecting the construction of telescopes. "Lenses and specula," says he, "may be so figured that one object may be multiplied into many, that those which are situated at a great distance may be

made to appear very near, that those which are small may be made to appear very large, and those which are obscure, very plain; and we can make stars to appear wherever we will." From these expressions, it appears highly probable that this philosopher was acquainted with the general principle both of telescopes and microscopes, and that he may have constructed telescopes of small magnifying power for his own observation and amusement, although they never came into general use. He was a man of extensive learning, and made so rapid a progress in the sciences, when attending the University of Paris, that he was esteemed the glory of that seat of learning. He prosecuted his favorite study of experimental philosophy with unremitting ardor, and in this pursuit, in the course of twenty years, he expended no less than £2000 in experiments, instruments, and in procuring scarce books. In consequence of such extraordinary talents and such astonishing progress in the sciences in that ignorant age, he was represented, by the envy of his illiterate fraternity, as having dealings with the devil; and, under this pretense, he was restrained from reading lectures, and at length, in 1278, when sixty-four years of age, he was imprisoned in his cell, where he remained in confinement for ten years. He shone like a single bright star in a dark hemisphere—the glory of our country—and died at Oxford, in the year 1294, in the eightieth year of his age. "Friar Bacon," says the Rev. Mr. Jones, "may be considered as the first of English philosophers; his profound skill in mechanics, optics, astronomy, and chemistry would make an honorable figure in the present age. But he is entitled to further praise, as he made all his studies subservient to theology, and directed all his writings, as much as could be, to the glory of God. He had the highest regard for the sacred Scriptures, and was persuaded they contain the principles of all true science."

The next person who is supposed to have acquired a knowledge of telescopes was Joannes Baptista Porta, of Naples, who flourished in the sixteenth century. He discovered the *Camera Obscura*, the knowledge of which might naturally have led to the invention of the telescope; but it does not appear that he ever constructed such an instrument. Des Cartes considers James Metius, a Dutchman, as the first constructor of a telescope, and says that, "as he was amusing himself with making mirrors and burning-glasses, he casually thought of looking through two of his lenses at a time, and found that distant objects appeared very large and distinct." Others say that this great discovery was first made by John Lippersheim, a maker of spectacles at Middleburg, or, rather, by his children, who were diverting themselves with looking through two glasses at a time, and placing them at different distances from each other. But Borellus, who wrote a book "on the invention of the telescope," gives this honor to Zacharias Jansen, another spectacle maker in the same town, who, he says, made the first telescope in 1590. Jansen was a diligent inquirer into nature, and, being engaged in such pursuits, he was trying what use could be made of lenses for those purposes, when he fortunately hit upon the construction. Having found the arrangement of glasses which produced the effect desired, he inclosed them in a tube, and ran with his instrument to Prince Maurice, who, immediately conceiving that it might be of use to him in his wars, desired the author to keep it a secret. Such are the rude conceptions and selfish views of princely warriors, who would apply every invention in their power

for the destruction of mankind. But the telescope was soon destined to more noble and honorable achievements. Jansen, it is said, directed his instrument toward celestial objects, and distinctly saw the spots on the surface of the moon, and discovered many new stars, particularly several pretty considerable ones in the Great Bear. His son Johannes is said to have noticed the lucid circle near the lower limb of the moon, now named *Tycho*, from whence several bright rays seemed to dart in different directions. In viewing Jupiter, he perceived two, sometimes three, and, at the most, four small stars, a little above or below him, and thought that they performed revolutions around him. This was probably the first observation of the satellites of Jupiter, though the person who made it was not aware of the importance of his discovery.\*

It is not improbable that different persons about Middleburg hit upon the invention, in different modes, about the same time. Lippersheim seems to have made his first rude telescope by adjusting two glasses on a board, and supporting them on brass circles.† Other workmen, particularly Metius and Jansen, in emulation of each other, seem to have made use of that discovery, and by the new form they gave it, made all the honor of it their own. One of them, considering the effects of light as injurious to distinctness, placed the glasses in a tube blackened within. The other, still more cautious, placed the same glasses within tubes capable of sliding one in another, both to vary the prospects, by lengthening the instrument, according to the pleasure of the observer, and to render it portable and commodious. Thus it is probable that different persons had a share in the invention, and jointly contributed to its improvement. At any rate, it is undoubtedly to the Dutch that we owe the original invention. The first telescope made by Jansen did not exceed fifteen or sixteen inches in length, and therefore its magnifying power could not have been very great.

The famous Galileo has frequently been supposed to have been the inventor of the telescope, but he acknowledges that he had not the honor of being the original inventor, having first learned of a German that such an instrument had already been made; although, from his own account, it appears that he had actually reinvented this instrument. The following is the account, in his own words, of the circumstances which led him to construct a telescope: "Nearly ten months ago (namely, in April or May, 1609), it was reported that a certain Dutchman had made a perspective through which many distant objects appeared as distinct as if they were near. Several effects of this wonderful instrument were reported, which some believed and others denied; but, having it confirmed to me a few days after by a letter from the noble John Badoverie, at Paris, I applied myself to consider the reason of it, and by what means I might contrive a similar instrument, which I afterward attained to by the doctrine of refractions. And, first, I prepared a leaden tube, to whose extremities I fitted two spectacle glasses, both of them plane on one side, and on the other side one of them was spherically convex, and the other concave. Then applying

\* Though Borellus mentions this circumstance, yet there is some reason to doubt the accuracy of this statement, as young Jansen appears to have been at that period not more than six years old; so that it is more probable that Galileo was the first discoverer of Jupiter's satellites.

† The reader may see an engraving of this instrument in the author's work entitled "*The Improvement of Society*."

my eye to the concave, I saw objects appear pretty large and pretty near me. They appeared three times nearer and nine times larger in surface than to the naked eye; and soon after I made another, which represented objects about sixty times larger, and eight times nearer; and at last, having spared no labor or expense, I made an instrument so excellent as to show things almost a thousand times larger, and above thirty times nearer, than to the naked eye." In another part of his writings, Galileo informs us that "he was at Venice when he heard of Prince Maurice's instrument, but nothing of its construction; that the first night after he returned to Padua he solved the problem, and made his instrument the next day, and soon after presented it to the doge at Venice, who, to do him honor for his grand invention, gave him the ducal letters which settled him for life in his lectureship at Padua; and the Republic, on the 25th of August, in the same year (1610), more than tripled his salary as professor."

The following is the account which this philosopher gives of the process of reasoning which led him to the construction of a telescope: "I argued in the following manner: The contrivance consists either of one glass or more; one is not sufficient, since it must be either convex, concave, or plane; the last does not produce any sensible alteration in objects, the concave diminishes them; it is true that the convex magnifies, but it renders them confused and indistinct, consequently, one glass is insufficient to produce the desired effect. Proceeding to consider two glasses, and bearing in mind that the plane glass causes no change, I determined that the instrument could not consist of the combination of a plane glass with either of the other two. I therefore applied myself to make experiments on combinations of the two other kinds, and thus obtained that of which I was in search." If the true inventor is the person who makes the discovery by reasoning and reflection, by tracing facts and principles to their consequences, and by applying his invention to important purposes, then Galileo may be considered as the real inventor of the telescope. No sooner had he constructed this instrument—before he had seen any similar one—than he directed his tube to the celestial regions, and his unwearied diligence and ardor were soon rewarded by a series of new and splendid discoveries. He described the four satellites of Jupiter, and marked the periods of their revolutions; he discovered the phases of Venus, and thus was enabled to adduce a new proof of the Copernican system, and to remove an objection that had been brought against it. He traced on the lunar orb a resemblance to the structure of the earth, and plainly perceived the outlines of mountains and vales, casting their shadows over different parts of its surface. He observed that, when Mars was in quadrature, his figure varied slightly from a perfect circle, and that Saturn consisted of a triple body, having a small globe on each side, which deception was owing to the imperfect power of his telescope, which was insufficient to show him that the phenomenon was in reality a ring. In viewing the sun, he discovered large dark spots on the surface of that luminary, by which he ascertained that that mighty orb performed a revolution round its axis. He brought to view multitudes of stars imperceptible to the naked eye, and ascertained that those nebulous appearances in the heavens which constitute the Milky Way consist of a vast collection of minute stars too closely compacted together to produce an impression on our unassisted vision.

The results of Galileo's observations were given to the world in a small work, entitled "*Nuncius Siderius*," or, "News from the Starry Regions," which produced an extraordinary sensation among the learned. These discoveries soon spread throughout Europe, and were incessantly talked of, and were the cause of much speculation and debate among the circles of philosophers. Many doubted; many positively refused to believe so novel and unlooked-for announcements, because they ran counter to the philosophy of Aristotle and all the preconceived notions which then prevailed in the learned world. It is curious, and may be instructive, to consider to what a length of absurdity ignorance and prejudice carried many of those who made pretensions to learning and science. Some tried to reason against the facts alleged to be discovered; others contented themselves, and endeavored to satisfy others with the simple assertion that such things were not, and could not possibly be; and the manner in which they supported themselves in their incredulity was truly ridiculous. "O my dear Kepler," says Galileo, in a letter to that astronomer, "how I wish we could have one hearty laugh together. Here at Padua is the principal professor of philosophy, whom I have repeatedly and urgently requested to look at the moon and planets through my glass, which he pertinaciously refuses to do, lest his opinions should be overturned. Why are you not here? what shouts of laughter we should have at this glorious folly! and to hear the professor of philosophy at Pisa laboring with the Grand-duke with logical arguments, as if with magical incantations to charm the new planets out of the sky." Another opponent of Galileo, one Christmann, says, in a book he published, "We are not to think that Jupiter has four satellites given him by nature, in order, by revolving round him, to immortalize the Medici who first had notice of the observation. These are the *dreams of idle men*, who love ludicrous ideas better than our laborious and industrious correction of the heavens. Nature abhors so horrible a chaos, and to the truly wise such vanity is detestable." One Martin Horky, a would-be philosopher, declared to Kepler, "I will never concede his four new planets to that Italian from Padua, *though I should die for it*;" and he followed up this declaration by publishing a book against Galileo, in which he examines four principal questions respecting the alleged planets: 1. Whether they exist? 2. What they are? 3. What they are like? 4. Why they are? The first question is soon disposed of by declaring positively that he has examined the heavens with Galileo's own glass, and that no such thing as a satellite about Jupiter exists. To the second, he declares solemnly that he does not more surely know that he has a soul in his body than that reflected rays are the sole cause of Galileo's erroneous observations. In regard to the third question, he says that these planets are like the smallest fly compared to an elephant; and finally concludes, on the fourth, that the only use of them is to gratify Galileo's "thirst of gold," and to afford himself a subject of discussion. Kepler, in a letter to Galileo, when alluding to Horky, says, "He begged so hard to be forgiven, that I have taken him again into favor upon this preliminary condition, that I am to show him Jupiter's satellites, AND HE IS TO SEE THEM, and own that they are there."

The following is a specimen of the reasoning of certain pretended philosophers of that age against the discoveries of Galileo: Sizzi, a Florentine astronomer reasons in this strain: "There

are seven windows given to animals in the domicil of the head, through which the air is admitted to the rest of the tabernacle of the body, to enlighten, to warm, and to nourish it; two nostrils, two eyes, two ears, and a mouth; so in the heavens, or the great world, there are two favorable stars, two unpropitious, two luminaries, and Mercury alone undecided and indifferent. From which, and many other similar phenomena in nature, such as the seven metals, &c., we gather that the number of planets is necessarily seven. Moreover, the satellites are invisible to the naked eye, and therefore can exert no influence on the earth, and therefore would be useless, and therefore do not exist. Beside, as well the Jews as other ancient nations have adopted the division of the week into seven days, and have named them from the seven planets. Now, if we increase the number of the planets, this whole system falls to the ground." The opinions which then prevailed in regard to Galileo's observations on the moon were such as the following: Some thought that the dark shades on the moon's surface arose from the interposition of opaque bodies floating between her and the sun, which prevent his light from reaching those parts; others imagined that, on account of her vicinity to the earth, she was partly tainted with the imperfections of our terrestrial and elementary nature, and was not of that entirely pure and refined substance of which the more remote heavens consist; and a third party looked on her as a vast mirror, and maintained that the dark parts of her surface were the reflected images of our earthly forests and mountains.

Such learned nonsense is a disgrace to our species, and to the rational faculties with which man is endowed, and exhibits, in a most ludicrous manner, the imbecility and prejudice of those who made bold pretensions to erudition and philosophy. The statement of such facts, however, may be instructive, if they tend to guard us against those prejudices and preconceived opinions which prevent the mind from the cordial reception of truth, and from the admission of improvements in society which run counter to long-established customs. For the same principles and prejudices, though in a different form, still operate in society, and retard the improvement of the social state, the march of science, and the progress of Christianity. How ridiculous is it for a man calling himself a philosopher to be afraid to look through a glass to an existing object in the heavens, lest it should endanger his previous opinions! And how foolish is it to resist any improvement or reformation in society because it does not exactly accord with existing opinions and with "the wisdom of our ancestors!"

It is not a little surprising that Galileo should have first hit on that construction of a telescope which goes by his name, and which was formed with a *concave* glass next the eye. This construction of a telescope is more difficult to be understood in theory than one which is composed solely of convex glasses; and its field of view is comparatively very small, so that it is almost useless when attempted to be made of a great length. In the present day, we cannot help wondering that Galileo and other astronomers should have made such discoveries as they did with such an instrument, the use of which must have required a great degree of patience and address. Galileo's best telescope, which he constructed "with great trouble and expense," magnified the diameters of objects only thirty-three times; but its length is not stated, which would depend upon the focal dis-

tance of the concave eyeglass. If the eyeglass was two inches focus, the length of the instrument would be five feet four inches; if it was only one inch, the length would be two feet eight inches, which is the least we can allow to it—the object-glass being thirty-three inches focus, and the eyeglass placed an inch within this focus. With this telescope Galileo discovered the satellites of Jupiter, the crescent of Venus, and the other celestial objects to which we have alluded. The telescopes made in Holland are supposed to have been constructed solely of *convex* glasses, on the principle of the astronomical telescope; and if so, Galileo's telescope was in reality a new invention.

Certain other claimants of the invention of the telescope have appeared, beside those already mentioned. Francis Fontana, in his "Celestial Observations," says that he was assured by a Mr. Hardy, advocate of the Parliament of Paris, a person of great learning and undoubted integrity, that, on the death of his father, there was found among his things an old tube by which distant objects were distinctly seen, and that it was of a date long prior to the telescope lately invented, and had been kept by him as a secret. Mr. Leonard Digges, a gentleman who lived near Bristol in the seventeenth century, and was possessed of great and various knowledge, positively asserts in his "*Stratagemos*," and in another work, that his father, a military gentleman, had an instrument which he used in the field, by which he could bring distant objects near, and could know a man at the distance of three miles. Mr. Thomas Digges, in the preface to his "*Pantometria*," published in 1591, declares, "My father, by his continual painful practices, assisted by demonstrations mathematical, was able, and sundry times hath, by proportional glasses, duly situate in convenient angles, not only discovered things far off, read letters, numbered pieces of money, with the very coin and superscription thereof, cast by some of his friends of purpose, upon downs in open fields, but also, seven miles off, declared what hath been done that instant in private places. He hath also, sundry times, by the sunbeams, fired powder and discharged ordnance half a mile and more distant, and many other matters far more strange and rare, of which there are yet living divers witnesses."

It is by no means unlikely that persons accustomed to reflection, and imbued with a certain degree of curiosity, when handling spectacle glasses, and amusing themselves with their magnifying powers and other properties, might sometimes hit upon the construction of a telescope, as it only requires two lenses of different focal distances to be held at a certain distance from each other, in order to show distant objects magnified. Nay, even one lens, of a long focal distance, is sufficient to constitute a telescope of a moderate magnifying power, as I shall show in the sequel. But such instruments, when they happen to be constructed accidentally, appear to have been kept as secrets, and confined to the cabinets of the curious, so that they never came into general use; and as their magnifying power would probably be comparatively small, the appearance of the heavenly bodies would not be much enlarged by such instruments, nor is it likely that they would be often directed to the heavens. On the whole, therefore, we may conclude that the period when instruments of this description came into general use, and were applied to useful purposes, was when Galileo constructed his first telescopes.

## CHAPTER II.

### OF THE CAMERA OBSCURA.

BEFORE proceeding to a particular description of the different kinds of telescopes, I shall first give a brief description of the camera obscura, as the phenomena exhibited by this instrument tend to illustrate the principle of a refracting telescope.

The term *camera obscura* literally signifies a darkened vault or roof, and hence it came to denote a chamber, or box, or any other place made dark for the purpose of optical experiments. The camera obscura, though a simple, is yet a very curious and noble contrivance, as it naturally and clearly explains the manner in which vision is performed, and the principle of the telescope, and entertains the spectator with a most exquisite picture of surrounding objects, painted in the most accurate proportions and colors by the hand of nature. The manner of exhibiting the pictures of objects in a dark room is as follows: In one of the window-shutters of a room which commands a good prospect of objects not very distant, a circular hole should be cut of four or five inches diameter. In this hole an instrument should be placed called a *scioptic ball*, which has three parts, a frame, a ball, and a lens. The ball has a circular hole cut through the middle, in which the lens is fixed, and its use is to turn every way, so as to take in a view of objects on every side. The chamber should be made perfectly dark, and a white screen, or a large sheet of elephant paper, should be placed opposite to the lens, and in its focus, to receive the image. If, then, the objects without be strongly enlightened by the sun, there will be a beautiful living picture of the scene delineated on the white screen, where every object is beheld in its proportions, and with its colors even more vivid than life. Green objects appear in the picture more intensely green; and yellow, blue, red, or white flowers appear much more beautiful in the picture than in nature. If the lens be a good one, and the room perfectly dark, the perspective is seen in perfection. The lights and shadows are not only perfectly just, but also greatly heightened; and, what is peculiar to this delineation, and which no other picture or painting can exhibit, the *motions* of all the objects are exactly expressed in the picture; the boughs of the trees wave, the leaves quiver, the smoke ascends in a waving form, the people walk, the children at their sports leap and run, the horse and cart move along, the ships sail, the clouds soar and shift their aspects, and all as natural as in the real objects; the motions being somewhat quicker, as they are performed in a more contracted scene.

These are the *inimitable* perfections of a picture drawn by the rays of light as the only pencil in nature's hand, and which are finished in a moment; for no sensible interval elapses before the painting is completed, when the ground on which it is painted is prepared and adjusted. In comparison of such a picture, the finest productions of the most celebrated artists, the proportions of Raphael, the natural tints and coloring of Titian,

and the shadowing of the Venetians, are but coarse and sorry daubing, when set in competition with what nature can exhibit by the rays of light passing through a single lens. The camera obscura is at the same time the painter's assistant and the painter's reproach. From the picture it forms he receives his best instructions, and he is shown what he should endeavor to attain; and hence, too, he learns the imperfections of his art, and what it is impossible for him to imitate. As a proof of this, the picture formed in the dark chamber will bear to be magnified to a great extent, without defacing its beauty or injuring the fineness of its parts; but the finest painted landscape, if viewed through a high magnifier, will appear only as a coarse daubing.

The following scheme will illustrate what has been now stated respecting the dark chamber: *E F* represents a darkened room, in the side of which, *I K*, is made the circular hole *V*, in which, on the inside, is fixed the scioptic ball. At some considerable distance from this hole is exhibited a landscape of houses, trees, and other objects,

Fig. 37.

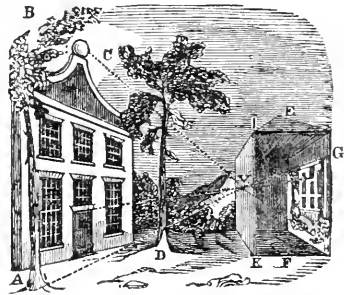

*A B C D*, which are opposite to the window: The rays which flow from the different objects which compose this landscape to the lens at *V*, and which pass through it, are converged to their respective foci on the opposite wall of the chamber, *H G*, or on a white movable screen placed in the focus of the lens, where they all combine to paint a lively and beautiful picture of the range of objects directly opposite, and on each side, so far as the lens can take in.

Though I have said that a scioptic ball and socket are expedient to be used in the above experiment, yet, where such an instrument is not at hand, the lens may be placed in a short tube, made of pasteboard or any other material, and fixed in the hole made in the window-shutter. The only imperfection attending this method is, that the lens can exhibit those objects only which lie directly opposite the window.

Some may be disposed to consider it as an imperfection in this picture, that all these objects appear in an *inverted* position; as they must ne-



cessarily do, according to what we formerly stated respecting the properties of convex lenses (p. 28). There are, however, different modes of viewing the picture as if it were erect; for if we stand before the picture, and hold a common mirror against our breast at an acute angle with the picture, and look down upon it, we shall see all the images of the objects as if restored to their erect position; and by the reflection of the mirror, the picture will receive such a luster as will make it still more delightful. Or, if a large concave mirror were placed before the picture at such a distance that its image may appear before the mirror, it will then appear erect and pendulous in the air in the front of the mirror. Or, if the image be received on a frame of paper, we may stand behind the frame, with our face toward the window, and look down upon the objects, when they will appear as if erect.

The experiment of the camera obscura may serve to explain and illustrate the nature of a common refracting telescope. Let us suppose that the lens in the window-shutter represents the object-glass of a refracting telescope. This glass forms an image in its focus, which is in every respect an exact picture or representation of the objects before it; and consequently the same idea is formed in the mind of the nature, form, magnitude, and color of the object, whether the eye at the center of the glass views the object itself, or the image formed in its focus; for, as formerly stated, the object and its image are both seen under the same angles by the eye placed at the center of the lens. Without such an image as is formed in the camera obscura—depicted either in the tube of a telescope or in the eye itself—no telescope could possibly be formed. If we now suppose that, behind the image formed in the dark chamber, we apply a convex lens of a short focal distance to view that image, then the image will be seen distinctly, in the same manner as we view common objects, such as a leaf or a flower, with a magnifying glass; consequently, the object itself will be seen distinct and magnified; and as the same image is nearer to one lens than the other, it will subtend a larger angle at the nearest lens, and, of course, will appear larger than through the other, and consequently the object will be seen magnified in proportion. For example, let us suppose the lens in the camera obscura, or the object lens of a telescope, to be five feet, or sixty inches focal distance: at this distance from the glass an image of the distant objects opposite to it will be formed. If, now, we place a small lens two inches focal distance beyond this point, or five feet two inches from the object-glass, the objects, when viewed through the small lens, will appear considerably magnified, and apparently much nearer than to the naked eye. The degree of magnifying power is in proportion to the focal distances of the two glasses; that is, in the present case, in the proportion of two inches, the focus of the small lens, to sixty inches, the focus of the object lens. Divide sixty by two, the quotient is thirty, which gives the magnifying power of such a telescope; that is, it represents objects thirty times nearer, or under an angle thirty times larger than to the naked eye. If the eyeglass, instead of being two inches, were only one and a half inch focus, the magnifying power would be in the proportion of one and a half to sixty, or forty times. If the eyeglass were three inches focus, the magnifying power would be twenty times; and so on with regard to other proportions. In all cases, where a telescope is composed of only two convex lenses, the magnifying power is de-

termined by dividing the focal distance of the object-glass by the focal distance of the eyeglass, and the quotient expresses the number of times the object is magnified in length and breadth. This and various other particulars will be more fully illustrated in the sequel.

In performing experiments with the camera obscura in a darkened chamber, it is requisite that the following particulars be attended to: 1. That the lens be well figured, and free from any veins or blemishes that might distort the picture. 2. That it be placed *directly against* the object whose image we wish to see distinctly delineated. 3. The lens should be of a proper size, both as to its breadth and focal distance. It should not be less than three or four feet focal distance, otherwise the picture will be too small, and the parts of objects too minute to be distinctly perceived; nor should it exceed fifteen or eighteen feet, as in this case the picture will be faint, and of course not so pleasing. The best medium as to focal distance is from five to eight or ten feet. The aperture, too, or breadth of the glass, should not be too small, otherwise the image will be obscure, and the minute parts invisible for want of a sufficient quantity of light. A lens of six feet focal distance, for example, will require an aperture of at least two inches. Lenses of a shorter focal distance require less apertures, and those of a longer focal distance larger. But if the aperture be too large, the image will be confused and indistinct, by the admission of too much light. 4. We should never attempt to exhibit the images of objects, unless when the sun is shining and strongly illuminating the objects, except in the case of very near objects placed in a good light. As one of the greatest beauties in the phenomena of the dark chamber consists in the exquisite appearance and contrast of light and shadows, nothing of this kind can be perceived but from objects directly illuminated by the sun. 5. A south window should never be used in the forenoon, as the sun cannot then enlighten the north side of an object; and, beside, his rays would be apt to shine upon the lens, which would make the picture appear with a confused luster. An east window is best in the afternoon, and a western in the morning; but a north window is in most cases to be preferred, especially in the forenoon, when the sun is shining with his greatest strength and splendor. In general, that window ought to be used which looks to the quarter opposite to that in which the sun is shining.

The picture should be received upon a very white surface, as the finest and whitest paper, or a painted cloth, bordered with black; as white bodies reflect most copiously the incumbent rays, while black surfaces absorb them. If the screen could be bent into the concave segment of a sphere, of which the focal distance of the double convex lens which is used is the radius, the parts of the picture adjacent to the extremities would appear most distinct. Sir D. Brewster informs us that, having tried a number of white substances of different degrees of smoothness, and several metallic surfaces on which to receive the image, he happened to receive the picture on the silvered back of a looking-glass, and was surprised at the brilliancy and distinctness with which external objects were represented. To remove the spherical protuberances of the tin foil, he ground the surface very carefully with a bed of hones which he had used for working the plane specula of Newtonian telescopes. By this operation, which may be performed without injuring the other side of the mirror, he obtained a surface finely

adapted for the reception of images. The minute parts of the landscape were formed with so much precision, and the brilliancy of coloring was so uncommonly fine, as to equal, if not exceed, the images that are formed in the air by means of concave specula.

The following additional circumstances may be stated respecting the phenomena exhibited in the dark chamber: A more critical idea may be formed of any *movement* in the picture here presented than from observing the motion of the object itself. For instance, a man walking in a picture appears to have an undulating motion, or to rise up and down every step he takes, and the hands seem to move almost exactly like a pendulum; whereas scarcely anything of this kind is observed in the man himself, as viewed by the naked eye. Again, if an object be placed just twice the focal distance from the lens without the room, the image will be formed at the same distance from the lens within the room, and, consequently, will be equal in magnitude to the object itself. The recognition of this principle may be of use to those concerned in drawing, and who may wish at any time to form a picture of the exact size of the object. If the object be placed farther from the lens than twice its focal length, the image will be less than the object. If it be placed nearer, the image will be greater than the life. In regard to immovable objects, such as houses, gardens, trees, &c., we may form the images of so many different sizes by means of different lenses, the shorter focus making the lesser picture, and the longer focal distance the largest.

The experiments with the camera obscura may likewise serve to illustrate the nature of vision and the functions of the human eye. The frame or socket of the scioptic ball may represent the *orbit* of the natural eye. The ball, which turns every way, resembles the *globe* of the eye, movable in its orbit. The hole in the ball may represent the *pupil* of the eye; the convex lens corresponds to the *crystalline humor*, which is shaped like a lens, and contributes to form the images of objects on the inner part of the eye. The dark chamber itself is somewhat similar to the *internal part of the eye*, which is lined all around, and under the retina, with a membrane, over which is spread a mucus of a very black color. The white wall or frame of white paper to receive the picture of objects is a fair representation of the *retina* of the eye, on which all the images of external objects are depicted. Such are some of the general points of resemblance between the apparatus connected with the dark chamber and the organ of vision; but the human eye is an organ of such exquisite construction, and composed of such a number and variety of delicate parts, that it cannot be adequately represented by any artificial contrivance.

The darkened chamber is frequently exhibited in a manner somewhat different from what we have above described, as in the following scheme (fig. 3c), which is termed the *revolving camera obscura*. In this construction, *K H* represents a plane mirror or metallic reflector, placed at half a right angle to the convex lens *H I*, by which rays proceeding from objects situated in the direction *O* are reflected to the lens, which forms an image of the objects on a round white table at *T*, around which several spectators may stand and view the picture as delineated on a horizontal plane. The reflector, along with its case, is capable of being turned round by means of a simple apparatus connected with it, so as to take in, in succession, all the objects which compose the surrounding

scene. But as the image here is received on a flat surface, the rays, *f m, e n*, will have to diverge farther than the central rays, *d c*; and hence the representation of the object near the sides will be somewhat distorted; to remedy which, the lens

Fig. 38.

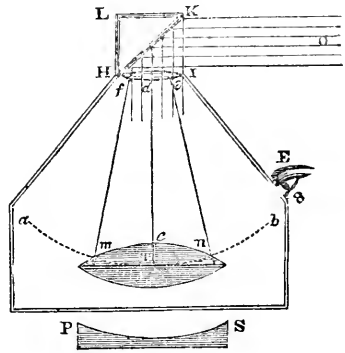

should be received on a concave surface, as *a b* or *P S*. This is the general plan of those camera obscuras fitted up in large wooden tents, which are frequently exhibited in our large cities, and removed occasionally from one town to another. Were an instrument of this kind fitted up on a *small scale*, a hole might be made in one of the sides, as at *E*, where the eye could be applied to view the picture. The focal distances of the lenses used in large instruments of this kind are generally from eight to twelve feet, in which case they produce a telescopic effect upon distant objects, so as to make them appear nearer than when viewed with the naked eye.

The camera obscura is frequently constructed in a *portable form*, so as to be carried about for the purpose of delineating landscapes. The following is a brief description of the instrument in this form; *A C* is a convex lens, placed near the

Fig. 39.

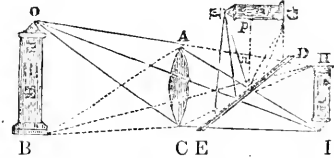

end of a tube or drawer, which is movable in the side of a square box, within which is a plane mirror, *D E*, reclining backward in an angle of forty-five degrees from the perpendicular, *p n*.—The pencils of rays flowing from the object *O B*, and passing through the convex lens, instead of proceeding forward and forming the image *H I*, are reflected upward by the mirror, and meet in points, as *F G*, at the same distance at which they would have met at *H* and *I*, if they had not been intercepted by the mirror. At *F G*, the image of the object *O B*, is received either on a piece of oiled paper, or more frequently on a plane *unpolished* glass, placed in the horizontal situation *F G*, which receives the images of all objects opposite to the lens, and on which, or on an oiled paper placed upon it, their outlines may be traced by a pencil. The movable tube on which the lens is fixed serves to adjust the focus

for near and distant objects, until their images appear distinctly painted on the horizontal glass at *F G*. The following is the most common form of the box of this kind of camera obscura. *A* is the position of the lens, *B C* the position of the mirror, *D* the plane unpolished glass on which the images are depicted, *G H* a movable top or screen to prevent the light from injuring the picture, and *E F* the movable tube.

*The Daguerreotype.*—An important and somewhat surprising discovery has lately been made in relation to the picture formed by the camera obscura. It is found that the images formed by this instrument are capable of being indelibly fixed on certain surfaces previously prepared for the purpose, so that the picture is rendered permanent. When a camera is presented to any object

Fig. 40.

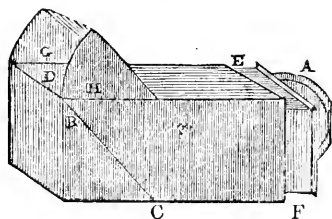

or landscape strongly illuminated by the sun, and the prepared ground for receiving the image is adjusted, and a certain time allowed to elapse until the rays of light produce their due effect, in a few minutes, or even seconds, a picture of the objects opposite to the lens is indelibly impressed upon the prepared plate, in all the accurate proportions and perspective which distinguish the images formed in a dark chamber, which representation may be hung up in apartments, along with other paintings and engravings, and will likely retain their beauty and luster for many years. These are pictures of nature's own workmanship, finished in an extremely short space of time, and with the most exquisite delicacy and accuracy.—The effect is evidently owing to certain chemical properties in the rays of light, and opens a new field for experiment and investigation to the philosopher. The only defect in the picture is, that it is not colored; but, in the progress of experiments, on this subject, it is not unlikely that even this object may be accomplished, in which case we should be able to obtain the most accurate landscapes and representations of all objects which can possibly be formed. This art or discovery goes by the name of the *Daguerreotype*, from M. Daguerre, a Frenchman, who is supposed to have been the first discoverer, and who received a large premium from the French government for disclosing the process, and making the discovery public. Several improvements and modifications, in reference to the preparation of the plates, have been made since the discovery was first announced, about the beginning of 1839; and the pictures formed on this principle are frequently distinguished by the name of *Photogenic* drawings, and are now exhibited at most of our public scientific institutions.

This new science or art has been distinguished by different names. It was first called *Photography*, from two Greek words, signifying *writing by light*: it was afterward called the art of *Photogenic Drawing*, or *writing produced by light*. M. Daguerre gave it the name of *Heliography*, or

*writing by the sun*; all which appellatives are derived from the Greek, and are expressive, in some degree, of the nature of the process. We shall, however, make use of the term *Daguerreotype*, derived from the name of the inventor.

As it does not fall within our plan to give any minute descriptions of the *Daguerreotype* process, we shall just give a few general hints in reference to it, referring those who wish for particular details to the separate treatises which have been published respecting it. The first thing necessary to be attended to in this art is the preparation of the plate on which the drawing is to be made. The plate consists of a thin leaf of copper, plated with silver, both metals together not being thicker than a card. The object of the copper is simply to support the silver, which must be the purest that can be procured. But, though the copper should be no thicker than to serve the purpose of support, it is necessary that it should be so thick as to prevent the plate from being warped, which would produce a distortion of the images traced upon it. This plate must be polished; and for this purpose the following articles are required: a vial of olive oil; some very fine cotton; pumice-powder ground, until it is almost impalpable, and tied up in a piece of fine muslin, thin enough to let the powder pass through without touching the plate when the bag is shaken; a little nitric acid, diluted with sixteen times, by measure, its own quantity of water; a frame of wire on which to place the plate when being heated; a spirit lamp to make the plate hot; a small box, with inclined sides within, and having a lid to shut it up close; and a square board large enough to hold the drawing, and having catches at the side to keep it steady.

To the above prerequisites, a good *camera obscura* is, of course, essentially necessary. This instrument should be large enough to admit the plate of the largest drawing intended to be taken. The lens which forms the image of the object should, if possible, be *achromatic*, and of a considerable diameter. In an excellent instrument of this description now before me, the lens is an achromatic about three inches diameter, but capable of being contracted to a smaller aperture.—Its focal distance is about 17 inches; and the box, exclusive of the tube which contains the lens, is 15 inches long, 13½ inches broad, and 11 inches deep. It forms a beautiful and well-defined picture of every well enlightened object to which it is directed.

Before the plate is placed in the camera, there are certain operations to be performed. 1. The surface of the plate should be made perfectly smooth or highly polished. For this purpose it must be laid flat, with the silver side upward, upon several folds of paper for a bedding; and having been well polished in the usual way, the surface must be powdered equally and carefully with fine pumice inclosed in the muslin bag.—Then taking a little cotton wool, dipped in olive oil, it must be rubbed over the plate with round strokes, and then crossing them by others which commence at right angles with the first.—This process must be repeated frequently, changing the cotton, and renewing the pumice-powder every time. A small portion of cotton must now be moistened with the diluted nitric acid, and applied equally to the whole surface. The next thing to be done is to make the plate thoroughly and equally hot, by holding the plate with a pair of pinchers by the corner over a charcoal fire, and when the plate is sufficiently hot, a white coating will be observed on the silver, which indicates that

that part of the operation is finished. An even cold surface is next wanted, such as a metallic plate cooled almost to the freezing point by muriate of soda, and to this the heated plate must be suddenly transferred.

2. The next operation is to give the plate a coating of *iodine*. This is accomplished by fixing the plate upon a board, and then putting it into a box containing a little dish with iodine divided into small pieces, with its face downward, and supported with small brackets at the corners. In this position the plate must remain until it assume a full gold color, through the condensation of the iodine on its surface, which process should be conducted in a darkened apartment. The requisite time for the condensation of the iodine varies from five minutes to half an hour. When this process is satisfactorily accomplished, the plate should be immediately fixed in a frame with catches and bands, and placed in the camera; and the transference from one receptacle to another should be made as quickly as possible, and with only so much light as will enable the operator to see what he is doing.

3. The next operation is to obtain the drawing. Having placed the camera in front of the scene to be represented, and the lens being adjusted to the proper focus, the ground glass of the camera is withdrawn, and the prepared plate is substituted for it, and the whole is left until the natural images are drawn by the natural light from the object. The time necessary to leave the plate for a complete delineation of the objects depends upon the intensity of the light. Objects in the shade will require more time for their delineation than those in the broad light. The full, clear light of the south of Europe, Spain, Italy, and particularly the more glowing brilliancy of tropical countries, will effect the object much more speedily than the duller luminosity of a northern clime. Some hours of the day are likewise more favorable than others. Daguerre states that "the most favorable is from 7 A. M., to 3 o'clock, P. M., and that a drawing could be effected in Paris in three or four minutes in June and July, which would require five or six in May and August, and seven or eight in April and September." In the progress of this art, at the present time, portraits and other objects are frequently delineated in the course of a few seconds.

4. Immediately after removing the plate from the camera, it is next placed over the vapor of mercury, which is placed in a cup at the bottom of a box, and a spirit lamp applied to its bottom until the temperature rise to 140° of Fahrenheit. This process is intended to bring out the image, which is not visible when withdrawn from the camera; but in the course of a few minutes, a faint tracery will begin to appear, and in a very short time the figure will be clearly developed.

5. The next operation is to fix the impression. In order to this, the coating on which the design was impressed must be removed, to preserve it from being decomposed by the rays of light. For this purpose, the plate is placed in a trough containing common water, plunging and withdrawing it immediately, and then plunging it into a solution of salt and water until the yellow coating has disappeared.

Such is a very brief sketch of the *photogenic* processes of Daguerre. Other substances, however, more easily prepared, have been recommended by Mr. Talbot, F.R.S., who appears, about the same time to have invented a process, somewhat similar to that of Daguerre. The following are his directions for the preparation of *photogenic paper*:

The paper is to be dipped into a solution of salt in water, in the proportion of half an ounce of salt to half a pint of water. Let the superfluous moisture drain off, and then laying the paper upon a clean cloth, dab it gently with a napkin, so as to prevent the salt collecting in one spot more than in another. The paper is then to be pinned down, by two of its corners, on a drawing board, by means of common pins, and one side washed or wetted with the photogenic fluid, using the brush prepared for that purpose, and taking care to distribute it equally. Next, dry the paper as rapidly as you can at the fire, and it will be fit for use for most purposes. If, when the paper is exposed to the sun's rays, it should assume an irregular tint, a very thin extra wash of the fluid will render the color uniform, and at the same time, somewhat darker. Should it be required to make a more sensitive description of paper, after the first application of the fluid the solution of salt should be applied, and the paper dried at the fire. Apply a second wash of the fluid, and dry it at the fire again: employ the salt a third time, dry it, and one application more of the fluid will, when dried, have made the paper extremely sensitive. When slips of such papers, differently prepared, are exposed to the action of daylight, those which are soonest affected by the light, by becoming dark, are the best prepared.

When photogenic drawings are finished in a perfect way, the designs then taken on the plate or paper are exceedingly beautiful and correct, and will bear to be inspected with a considerable magnifying power, so that the most minute portions of the objects delineated may be distinctly perceived. We have seen portraits finished in this way by a London artist with an accuracy which the best miniature painter could never attempt, every feature being so distinct as to bear being viewed with a deep magnifier. And in landscapes and buildings, such is the delicacy and accuracy of such representations, that the marks of the chisel and the crevices in the stones may frequently be seen by applying a magnifying lens to the picture; so that we may justly exclaim, in the words of the poet, "Who can paint like Nature!" That LIGHT—which is the first-born of Deity, which pervades all space, and illuminates all worlds—in the twinkling of an eye, and with an accuracy which no art can imitate, depicts every object in its exact form and proportions, superior to everything that human genius can produce.

The photogenic art, in its progress, will doubtless be productive of many highly interesting and beneficial effects. It affords us the power of representing, by an accurate and rapid process, all the grand and beautiful objects connected with our globe, the landscapes peculiar to every country, the lofty ranges of mountains which distinguish Alpine regions, the noble edifices which art has reared, the monumental remains of antiquity, and every other object which it would be interesting for human beings to contemplate; so that, in the course of time, the general scenery of our world, in its prominent parts, might be exhibited to almost every eye. The commission of the French Chambers, when referring to this art, has the following remark: "To copy the millions upon millions of hieroglyphics which cover even the exterior of the great monuments of Thebes and Memphis, of Carnac, &c., would require scores of years and legions of designers. By the assistance of the Daguerreotype, a single man could finish that immense work." This instrument lays down objects which the visual organs of man would overlook, or might be unable to perceive, with the

same minuteness and nicety that it delineates the most prominent features of a landscape. The time-stained excrescences on a tree, the blades of grass, the leaf of a rose, the neglected weed, the moss on the summit of a lofty tower, and similar objects, are traced with the same accuracy as the larger objects in the surrounding scene.

It is not improbable, likewise, that this art (still in its infancy), when it approximates to perfection, may enable us to take representations of the sublime objects in the heavens. The sun affords sufficient light for this purpose; and there appears no insurmountable obstacle in taking, in this way, a highly magnified picture of that luminary, which shall be capable of being again magnified by a powerful microscope. It is by no means improbable, from experiments that have hitherto been made, that we may obtain an accurate delineation of the lunar world from the moon herself. The plated discs prepared by Daguerre receive impressions from the action of the lunar rays to such an extent as permits the hope that photographic charts of the moon may soon be obtained; and, if so, they will excel in accuracy all the delineations of this orb that have hitherto been obtained; and if they should bear a microscopic power, objects may be perceived on the lunar surface which have hitherto been invisible. Nor is it impossible that the planets Venus, Mars, Jupiter, and Saturn may be delineated in this way, and objects discovered which cannot be described by means of the telescope. It might, perhaps, be

considered as beyond the bounds of probability to expect that even distant *nebulae* might thus be fixed, and a delineation of their objects produced which shall be capable of being magnified by microscopes; but we ought to consider that the art is yet only in its infancy, that plates of a more delicate nature than those hitherto used may yet be prepared, and that other properties of light may yet be discovered which shall facilitate such designs. For we ought now to set no boundaries to the discoveries of science, and to the practical applications of scientific discovery which genius and art may accomplish.

In short, this invention leads to the conclusion that we have not yet discovered all the wonderful properties of that luminous agent which pervades the universe, and which unavails to us its beauties and sublimities; and that thousands of admirable objects and agencies may yet be disclosed to our view through the medium of light, as philosophical investigators advance in their researches and discoveries. In the present instance, as well as in many others, it evidently appears that the Creator intends, in the course of his providence, by means of scientific researches, gradually to open to the view of the inhabitants of our world the wonders, the beauties, and the sublimities of his vast creation; to manifest his infinite wisdom and his superabundant goodness, and to raise our souls to the contemplation and the love of him who is the original source of all that is glorious and beneficent in the scene of nature.

## CHAPTER III.

### ON THE OPTICAL ANGLE, AND THE APPARENT MAGNITUDE OF OBJECTS.

In order to understand the principle on which telescopes represent distant objects as magnified, it may be expedient to explain what is meant by the angle of vision, and the apparent magnitudes under which different objects appear, and the same object, when placed at different distances.

The optical angle is the angle contained under two right lines drawn from the extreme points of an object to the eye. Thus  $AEB$  or  $CED$  (fig. 40\*) is the optical or visual angle, or the

Fig. 40\*

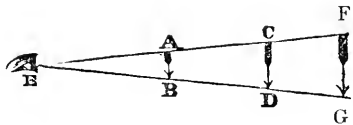

angle under which the object  $AB$  or  $CD$  appears to the eye at  $E$ . These two objects, being at different distances, are seen under the same angle, although  $CD$  is evidently larger than  $AB$ . On the retina of the eye, their images are exactly of the same size, and so is the still larger object  $FG$ .

The *apparent magnitude* of objects denotes their magnitude as they appear to us, in contradistinction from their real or true magnitude, and it is measured by the visual angle; for, whatever objects are seen under the same, or equal angles, appear equal, however different their real magnitudes. If a half crown or half dollar be placed

at about 120 yards from the eye, it is just perceptible as a visible point, and its apparent magnitude, or the angle under which it is seen, is very small. At the distance of thirty or forty yards, its bulk appears sensibly increased, and we perceive it to be a round body; at the distance of six or eight yards we can see the king or queen's head engraved upon it; and at the distance of eight or ten inches from the eye it will appear so large that it will seem to cover a large building placed within the distance of a quarter of a mile; in other words, the apparent magnitude of the half crown, held at such a distance, will more than equal that of such a building in the picture on the retina, owing to the increase of the optical angle. If we suppose  $A$  (fig. 41)

Fig. 41.

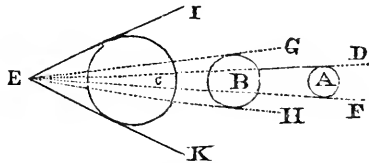

to represent the apparent size of the half crown at nine yards' distance, then we say it is seen under the small angle  $FED$ .  $B$  will represent its apparent magnitude at  $4\frac{1}{2}$  yards distant under the angle  $HEG$ , and the circle  $C$ , its apparent

magnitude at 3 yards distant, under the large angle  $KEI$ .

This may be otherwise illustrated by the following figure: Let  $AB$  (fig. 42) be an object

Fig. 42.

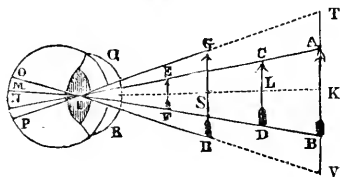

viewed directly by the eye  $QR$ . From each extremity  $A$  and  $B$  draw the lines  $AN$ ,  $BM$ , intersecting each other in the crystalline humor in  $I$ : then is  $AIB$  the optical angle which is the measure of the apparent magnitude or length of the object  $AB$ . From an inspection of this figure, it will evidently appear that the apparent magnitudes of objects will vary according to their distances. Thus  $A, B, C, D, E, F$ , the real magnitudes of which are unequal, may be situated at such distances from the eye as to have their *apparent* magnitudes all equal, and occupying the same space on the retina,  $MN$ , as here represented. In like manner, objects of equal magnitude, placed at unequal distances, will appear unequal. The objects  $AB$  and  $GH$ , which are equal, being situated at different distances from the eye,  $GH$  will appear under the large angle  $TVI$ , or as large as an object  $TV$ , situated at the same place as the object  $AB$ , while  $AB$  appears under the smaller angle  $AIB$ . Therefore the object  $GH$  is *apparently* greater than the object  $AB$ , though it is only equal to it. Hence it appears that we have no certain standard of the *true magnitude* of objects by our visual perception abstractly considered, but only of the *proportions* of magnitude.

In reference to apparent magnitudes, we scarcely ever judge any object to be so great or so small as it appears to be, or that there is so great a disparity in the visible magnitude of two equal bodies at different distances from the eye. Thus, for example, suppose two men, each six feet three inches high, to stand directly before us, one at the distance of a pole, or  $5\frac{1}{2}$  yards, and the other at the distance of 100 poles, or 550 yards: we should observe a considerable difference in their apparent size, but we should scarcely suppose, at first sight, that the one nearest the eye appeared a hundred times greater than the other, or that, while the nearest one appeared six feet three inches high, the remote one appeared only about *three-fourths* of an inch. Yet such is in reality the case; and not only so, but the visible bulk or area of the one is to that of the other as the square of these numbers, namely, as 10,000 to 1; the man nearest us presenting to the eye a magnitude or surface ten thousand times greater than that of the other. Again, suppose two chairs standing in a large room, the one twenty-one feet distance from us, and the other three feet; the one nearest us will appear seven times larger, both in length and breadth, than the more distant one, and, consequently, its visible area forty-nine times greater. If I hold up my finger at nine inches distance from my eye, it seems to cover a large town a mile and a half in extent, situated at three miles distance; consequently, the apparent magnitude of my finger, at nine inches distance from the organ of vision, is greater than that of the large town at three miles distance, and forms a larger

picture on the retina of the eye. When I stand at the distance of a foot from my window and look through one of the panes to a village less than a quarter of a mile distant, I see, through that pane, nearly the whole extent of the village, comprehending two or three hundred houses; consequently the apparent magnitude of the pane is equal to nearly the extent of the village, and all the buildings it contains do not appear larger than the pane of glass in the window, otherwise the houses and other objects which compose the village could not be seen through that single pane. For, if we suppose a line drawn from one end of the village, passing through the one side of the pane, and another line drawn from the other end, and passing through the other side of the pane to the eye, these lines would form the optical angle under which the pane of glass and the village appears. If the pane of glass be fourteen inches broad, and the length of the village 2640 yards, or half a mile, this last lineal extent is 6788 times greater than the other, and yet they have the same *apparent* magnitude in the case supposed.

Hence we may learn the absurdity and futility of attempting to describe the extent of spaces in the heavens, by saying that a certain phenomenon was two or three feet or yards distant from another, or that the tail of a comet appeared several yards in length. Such representations can convey no definite ideas in relation to such magnitudes, unless it be specified at what distance from the eye the foot or yard is supposed to be placed. If a rod, a yard in length, be held at nine inches from the eye, it will subtend an angle, or cover a space in the heavens, equal to more than one-fourth of the circumference of the sky, or about one hundred degrees. If it be eighteen inches from the eye, it will cover a space equal to fifty degrees; if at three feet, twenty-five degrees, and so on in proportion to the distance from the eye; so that we can form no correct conceptions of apparent spaces or distances in the heavens, when we are merely told that two stars, for example, appear to be three yards distant from each other. The only definite measure we can use in such a case is that of degrees. The sun and moon are about half a degree in apparent diameter, and the distance between the extreme stars in *Orion's belt* three degrees, which measures, being made familiar to the eye, may be applied to other spaces of the heavens, and an approximate idea conveyed of the relative distances of objects in the sky.

From what has been stated above, it is evident that the magnitude of objects may be considered in different points of view. The true dimensions of an object, considered in itself, give what is called its *real* or *absolute magnitude*; and the opening of the visual angle determines the *apparent magnitude*. The real magnitude, therefore, is a constant quantity; but the apparent magnitude varies continually with the distance, real or imaginary; and, therefore, if we always judge of the dimensions of an object from its apparent magnitude, everything around us would, in this respect, be undergoing very sensible variations, which might lead us into strange and serious mistakes. A fly, near enough to the eye, might appear under an angle as great as an elephant at the distance of twenty feet, and the one be mistaken for the other. A giant eight feet high, seen at the distance of twenty-four feet, would not appear taller than a child two feet in height at the distance of six feet; for both would be seen nearly under the same angle. But our experience generally prevents us from being deceived by such illusions. By the help of touch, and by making

allowance for the different distances at which we see particular objects, we learn to correct the ideas we might otherwise form from attending to the optical angle alone, especially in the case of objects that are near us. By the sense of touch we acquire an impression of the distance of an object; this impression combines itself with that of the apparent magnitude, so that the impression which represents to us the real magnitude is the product of these two elements. When the objects, however, are at a great distance, it is more difficult to form a correct estimate of their true magnitudes. The visual angles are so small that they prevent comparison; and the estimated bulks of the objects depend, in a great measure, upon the apparent magnitudes; and thus an object situated at a great distance appears to us much smaller than it is in reality. We also estimate objects to be nearer or farther distant according as they are more or less clear, and our perception of them more or less distinct and well-defined; and likewise when several objects intervene between us and the object we are particularly observing. We make a sort of addition of all the estimated distances of intermediate objects, in order to form a total distance of the remote object, which, in this case, appears to be farther off than if the inter-

vening space were unoccupied. It is generally estimated that no terrestrial object can be distinctly perceived if the visual angle it subtends be less than *one minute of a degree*, and that most objects become indistinct when the angle they subtend at the pupil of the eye is less than six minutes.

We have deemed it expedient to introduce the above remarks on the apparent magnitude of objects, because the principal use of a telescope is to increase the angle of vision, or to represent objects under a larger angle than that under which they appear to the naked eye, so as to render the view of distant objects more distinct, and to exhibit to the organ of vision those objects which would otherwise be invisible. A telescope may be said to enlarge an object just as many times as the angle under which the instrument represents it is greater than that under which it appears to the unassisted eye. Thus the moon appears to the naked eye under an angle of about half a degree; consequently, a telescope magnifies 60 times if it represents that orb under an angle of 30 degrees; and if it magnified 180 times, it would exhibit the moon under an angle of 90 degrees, which would make her appear to fill half of the visible heavens, or the space which intervenes from the horizon to the zenith.

## CHAPTER IV.

### ON THE DIFFERENT KINDS OF REFRACTING TELESCOPES.

THERE are two kinds of telescopes, corresponding to two modes of vision, namely, those which perform their office by *refraction* through lenses, and those which magnify distant objects by *reflection* from mirrors. The telescope which is constructed with lenses produces its effects solely by refracted light, and is called a *Dioptric, or refracting telescope*. The other kind of telescope produces its effects partly by reflection, and partly by refraction, and is composed both of mirrors and lenses; but the mirrors form the principal part of the telescope, and therefore such instruments are denominated *reflecting telescopes*. In this chapter I shall describe the various kinds of *refracting telescopes*.

#### SECTION I.

##### THE GALILEAN TELESCOPE.

THIS telescope is named after the celebrated Galileo, who first constructed, and probably invented it in the year 1609. It consists of only two glasses, a *convex* glass next the object, and a *concave* next the eye. The convex is called the *object-glass*, and the concave, to which the eye is applied, is called the *eye-glass*. Let *C* (fig. 43) represent the convex object-glass, presented to

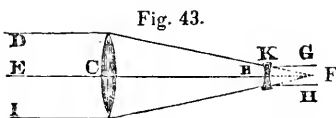

any object in the direction *D E I*, so that the rays fall parallel upon it; if these rays, after passing through it, were not intercepted by the concave lens *K*, they would pass on, and cross each

other in the focus *F*, where an inverted image of the object would be formed. But the concave lens *K*, the virtual focus of which is at *F*, being interposed, the rays are not suffered to converge to that point, but are made less convergent,\* and enter the pupil almost parallel, as *G H*, and are converged by the humors of the eye to their proper foci on the retina. The object, through this telescope, is seen upright, or in its natural position, because the rays are not suffered to come to a focus, so as to form an inverted picture. The concave eyeglass is placed as far within the focus of the object-glass as is equal to its own virtual focus; and the magnifying power is as the focal length of the object-glass to that of the eyeglass, that is, as *C F* to *B F*. Thus, suppose the focus of the object-glass to be ten inches, and the focus of the eyeglass to be one inch, the magnifying power will be ten times, which is always found by dividing the focal length of the object-glass by that of the eyeglass. The interval between the two glasses, in this case, will be nine inches, which is the length of the telescope, and the objects seen through it will appear under an angle ten times greater than they do to the naked eye. These propositions might be proved mathematically; but the process is somewhat tedious and intricate, and might not fully be understood by general readers. I shall therefore only mention some of the general properties of this telescope, which is now seldom used, except for the purpose of *opera-glasses*.

1. The focal distance of the object-glass must be greater than that of the eyeglass, otherwise it would not magnify an object; if the focal distance of the eyeglass were greater than that of

\* It is one of the properties of concave lenses to render convergent rays less convergent, and when placed as here supposed, to render them parallel; and it is parallel rays that produce distinct vision.

the object-glass, it would diminish objects instead of magnifying them. 2 The visible area of the object is greater, the nearer the eye is to the glass; and it depends on the diameter of the pupil of the eye, and on the breadth of the object-glass; consequently, the field of view in this telescope is very small. 3 The distinctness of vision in this construction of a telescope exceeds that of almost any other. This arises from the rays of light proceeding from the object directly through the lenses, *without crossing* or intersecting each other; whereas, in the combination of convex lenses, they intersect one another to form an image in the focus of the object-glass, and this image is magnified by the eyeglass with all its imperfections and distortions. The thinness of the center of the concave lens also contributes to distinctness. 4. Although the field of view in this telescope is very small, yet, where no other telescope can be procured, it might be made of such a length as to show the spots on the sun, the crescent of Venus, the satellites of Jupiter, and the ring of Saturn; and, requiring only two glasses, it is the cheapest of all telescopes. It has been found that an object-glass five feet focal distance will bear a concave eyeglass of only one inch focal distance, and will consequently magnify the diameters of the planets sixty times, and their surfaces 3600 times, which is sufficient to show the phenomena now stated. And, although only a small portion of the sun and moon can be seen at once, yet Jupiter and all his satellites may sometimes be seen at one view; but there is some difficulty in finding objects with such telescopes. 5. Opera-glasses, which are always of this construction, have the object-glass generally about six inches focus and one inch diameter, with a concave eyeglass of about two inches focus. These glasses magnify about three times in diameter, have a pretty large field, and produce very distinct vision. When adjusted to the eye they are about four inches in length. To the object-end of an opera-glass there is sometimes attached a plane mirror, placed at an angle of forty-five degrees, for the purpose of viewing objects on either side of us. By this means, in a theater or assembly, we can take a view of any person without his having the least suspicion of it, as the glass is directed in quite a different direction. The instrument with this appendage is sometimes called a *Polemoscope*.

## SECTION II.

### THE COMMON ASTRONOMICAL REFRACTING TELESCOPE.

THE astronomical telescope is the most simple construction of a telescope, composed of convex lenses only, of which there are but two essentially necessary, though a third is sometimes added to the eyepiece for the purpose of enlarging the field of view. Its construction will be easily understood from a description of the following figure: Its two essential parts are an object-glass, *A D*, and an eyeglass *E Y*, so combined in a tube that the focus *F* of the object-glass is exactly coincident with the focus of the eyeglass. Let *O B* (fig. 44) represent a distinct object, from which rays nearly parallel proceed to the object-glass *A D*. The rays passing through this lens will cross at *F*, and form an image of the object at *I M*. This image forms, as it were, an object to the eyeglass *E Y*, which is of a short focal distance, and the eye is

thus enabled to contemplate the object as if it were brought much nearer than it is in reality; for the rays, which, after crossing, proceed in a divergent state, fall upon the lens *E Y* as if they proceeded from a real object situated at *F*. All that is effected, therefore, by such a telescope is to form an image of a distant object by means of the object-glass, and then to give the eye such assistance as is necessary for viewing that image as near as possible, so that the angle it shall subtend at the eye shall be very large compared with the angle which the object itself would subtend in the same situation.

Here it may be expedient to explain, 1. How this arrangement of glasses shows distant objects distinctly; and 2. The reason why objects appear magnified when seen through it. As to the first particular, it may be proved as follows: The rays *O A* and *B D*, which are parallel before they fall upon the object-glass, are by this glass refracted and united at its focus. In order, then, to distinct vision, the eyeglass must re-establish the parallelism of the rays, which is effected by placing the eyeglass so that its focus may be at *F*, and, consequently, the rays will proceed from it parallel to each other, and fall upon the eye in that direction; for distinct vision is produced by parallel rays. 2. The reason why the object appears magnified will appear, if we consider that, if the eye viewed the object from the center of the object glass, it would see it under the angle *O C B*; let *O C* and *B C* then be produced to the focus of the glass, they will then limit the image, *I M*, formed in the focus. If, then, two parallel rays are supposed to proceed to the eyeglass *E Y*, they will be converged to its focus *H*, and the eye will see the image under the angle *E H Y*. The apparent magnitude of the object, therefore, as seen by the naked eye, is to the magnitude of the image as seen through the telescope, as *O C B* to *E H Y*, or as the distance *C P* to the distance *F G*; in other words, as the focal length of the object-glass to that of the eyeglass.

It is obvious from the figure, that, through this telescope, all objects will appear *inverted*; since the object *O B* is depicted by the object-glass in an inverted position at *I M*, and in this position is viewed by the eyeglass *E Y*; and, therefore, this kind of telescope is not well adapted for viewing terrestrial objects, since it exhibits the tops of trees, houses, and other objects as undermost, and the heads of people as pointing downward. But this circumstance is of no consequence with respect to the heavenly bodies, since they are round, and it can make little difference to an observer which side of a globular body appears uppermost or undermost. All astronomical refracting telescopes invert objects; but they are preferred to any other telescopes, because they have few glasses, and, consequently, more light. This telescope, however, can be transformed into a common day telescope for land objects by the addition of two other eyeglasses, as we shall afterwards explain; but in this case a quantity of light is lost by refraction at each lens, for there is scarcely any transparent substance that transmits all the rays of light that fall upon it.

The *magnifying power* of this telescope is found by dividing the focal distance of the object-glass by the focal distance of the eyeglass; the quotient

Fig. 44.

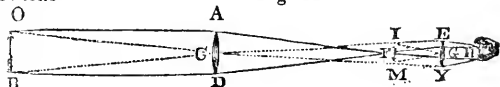



gives the magnifying power, or the number of times that the object seen through the telescope appears larger or nearer than to the naked eye. Thus, for example, if the focal distance of the object-glass be 28 inches, and the focal distance of the eyeglass 1 inch, the magnifying power will be 28 times. If we would enlarge the telescope, and select an object-glass 10 feet, or 120 inches focus, an eyeglass of 2 inches focal length might be applied, and then the diameter of objects would be magnified 60 times, and their surfaces 3600 times. If we would use an object-glass of 100 feet, it would be necessary to select an eyeglass about 6 inches focus, and the magnifying power would be 200 times, equal to 1200 inches divided by 6. Since, then, the power of magnifying depends on the proportion of the focal length of the object and eyeglasses, and this proportion may be varied to any degree, it may seem strange to some that a short telescope of this kind will not answer that purpose as well as a long one. For instance, it may be asked why an object-glass of 10 feet focus may not be made to magnify as much as one of 100 feet focal length, by using an eyeglass of half an inch focus, in which case the magnifying power would be 240 times? But it is to be considered that, if the power of magnifying be increased while the length of the telescope remains the same, it is necessary to diminish the focal length of the eyeglass in the same proportion, and this cannot be done, on account of the great distortion and coloring which would then appear in the image, arising both from the deep convexity of the lens and the different refrangibility of the rays of light. It is found that the length of common refracting telescopes must be increased in proportion to the square of the increase of their magnifying power; so that, in order to magnify twice as much as before with the same light and distinctness, the telescope must be lengthened four times; to magnify 3 times as much, 9 times; and to magnify 4 times as much, 16 times; that is—suppose a telescope of 3 feet to magnify 33 times—in order to procure a power four times as great, or 132 times, we must extend

upon the breadth or aperture of the object-glass. If it be too small, there will not be sufficient light to illuminate the object; and if it be too large, the redundancy of light will produce confusion in the image.

The foregoing table, constructed originally by Huygens, and which I have recalculated and corrected, shows the linear aperture, the focal distance of the eyeglass, and the magnifying power of astronomical telescopes of different lengths, which may serve as a guide to those who wish to construct telescopes of this description.

In the above table the first column expresses the focal length of the object-glass in feet, the second column the diameter of the aperture\* of the object-glass, the third column the focal distance of the eyeglass, and the fourth the magnifying power, which is found by reducing the feet in the first column to inches, and dividing by the numbers in the third column. From this table it appears that, in order to obtain a magnifying power of 168 times by this kind of telescope, it is requisite to have an object-glass of 70 feet focal distance, and an eyeglass five inches focus, and that the aperture of the object-glass ought not to be more than about  $4\frac{1}{2}$  inches diameter. To obtain a power of 220 times requires a length of 120 feet.

The following is a summary view of the properties of this telescope: 1. The object is always inverted. 2. The magnifying power is always in the proportion of the focal distance of the object-glass to the eyeglass. 3. As the rays emerging from the eyeglass should be rendered parallel for every eye, there is a small sliding tube next the eye, which should be pushed out or in until the object appears distinct. When objects are pretty near, this tube requires to be pulled out a little. These circumstances require to be attended to in all telescopes. 4. The apparent magnitude of an object is the same wherever the eye be placed, but the visible area, or field of view, is the greatest when the eye is nearly at the focal distance of the eyeglass. 5. The visual angle depends on the breadth of the eyeglass, for it is equal to the angle which the eyeglass subtends at the object-glass; but the breadth of the eyeglass cannot be increased beyond a certain limit without producing coloring and distortion.

If the general principles on which this telescope is constructed be thoroughly understood, it will be quite easy for the reader to understand the construction of all the other kinds of telescopes, whether refracting or reflecting. A small astronomical telescope can be constructed in a few moments, provided one has at hand the following lenses: 1. A common reading-glass, eight or ten inches focal distance: 2. A common magnifying lens, such as watchmakers or botanists use, of about  $1\frac{1}{2}$  or 2 inches focus. Hold the reading-glass—suppose of ten inches focus—in the left hand opposite any object, and the magnifying lens of two inches focus in the right hand near the eye, at twelve inches distance from the other in a direct line, and a telescope is formed which magnifies five times. I have frequently used this plan, when traveling, when no other telescope was at hand.

Focal distance of the object-glass.	Linear aperture of the object-glass.	Focal distance of the eyeglass.	Magnifying power.
Feet.	Inc. Dec.	Inc. Dec.	
1	0. 545	0. 60	20
2	0. 76	0. 84	28.5
3	0. 94	1. 04	34.6
4	1. 08	1. 18	40
5	1. 21	1. 33	45
6	1. 32	1. 45	50
7	1. 43	1. 58	53
8	1. 53	1. 69	56.8
9	1. 62	1. 78	60.6
10	1. 71	1. 88	63.8
15	2. 10	2. 30	78
20	2. 43	2. 68	89.5
30	3. 00	3. 28	109
40	3. 43	3. 76	127
50	3. 84	4. 20	142
60	4. 20	4. 60	156
70	4. 55	5. 00	168
80	4. 83	5. 35	179
90	5. 15	5. 65	190
100	5. 40	5. 95	200
120	5. 90	6. 52	220

the telescope to the length of 48 feet, or 16 times the length of the other. Much, likewise, depends

\* The word *aperture*, as applied to object-glasses, signifies the opening to let in the light, or that part of the object-glass which is left uncovered. An object-glass may be 3 inches in diameter, but if one inch of this diameter be covered, its aperture is said to be only 2 inches.

## SECTION III.

## THE AERIAL TELESCOPE.

THE aerial is a refracting telescope of the kind we have now described, intended to be used without a tube in a dark night; for the use of a tube is not only to direct the glasses, but to make the place dark where the images are formed. It appears, from the preceding table, that we cannot obtain a high magnifying power with the common astronomical telescope without making it of an extreme length, in which case the glasses are not manageable in tubes—which are either too slight and apt to bend, or too heavy and unwieldy if made of wood, iron, or other strong materials. The astronomers of the seventeenth century, feeling some inconveniences in making celestial observations with long tubes, contrived a method of using the glasses without tubes. Hartsocker, an eminent optician, contrived to fix them at the top of a tree, a high wall, or the roof of a house; but the celebrated Huygens, who was not only an astronomer, but also an excellent mechanic, made considerable improvements in the method of using an object-glass without a tube. He placed it at the top of a very long pole, having previously inclosed it in a short tube, which was made to turn in all directions by means of a ball and socket.—The axis of this tube he could command with a fine silken string, so as to bring it into a line with the axis of another short tube which he held in his hand, and which contained the eyeglass.—

Fig. 45.

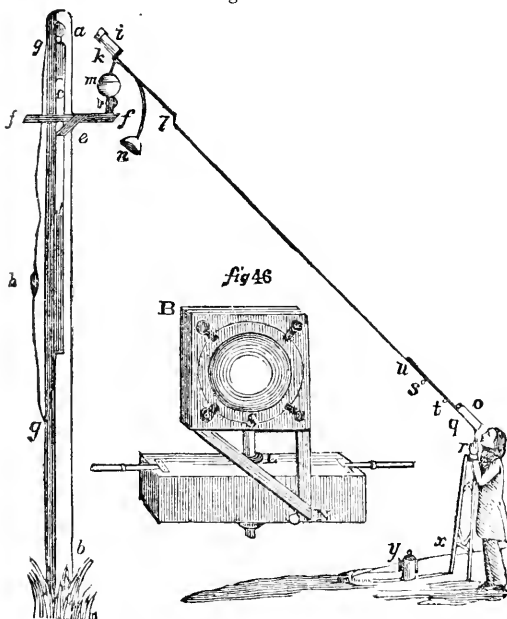

The following is a more particular description of one of these telescopes: On the top of a long pole or mast *a b* (fig. 45), is fixed a board movable up and down in the channel *c d*; *e* is a perpendicular arm fixed to it, and *f f* is a transverse board that supports the object-glass inclosed in the tube *i*, which is raised or lowered by means of the silk cord *r l*; *g g* is an endless rope with a weight *h*, by which the apparatus of the object-glass is counterpoised; *k l* is a stick fastened to the tube *i*; *m* the ball and socket, by means of which the object-glass is movable every way; and,

to keep it steady, there is a weight, *n*, suspended by a wire; *l* is a short wire to which the thread *r l* is tied; *o* is the tube which holds the eyeglass; *q* the stick fixed to this tube, *s* a leaden bullet, and *t* a spool to wind the thread on; *u* is pins for the thread to pass through; *x* the rest for the observer to lean upon, and *y* the lantern. Fig. 46 is an apparatus contrived by M. de la Hire for managing the object-glass, but which it would be too tedious particularly to describe. To keep off the dew from the object-glass, it was sometimes included in a pasteboard tube, made of spongy paper, to absorb the humidity of the air. And, to find an object more readily, a broad annulus of white pasteboard was put over the tube that carried the eyeglass, upon which the image of the object being painted, an assistant who perceived it might direct the tube of the eyeglass into its place.

Such was the construction of the telescopes with which Hevelius, Huygens, Cassini, and other eminent astronomers of the seventeenth century made their principal discoveries. With such telescopes Huygens discovered the fourth satellite of Saturn, and determined that this planet was surrounded with a ring; and with the same kind of instrument Cassini detected the first, second, third, and fifth satellites of Saturn, and made his other discoveries. When the night was very dark, they were obliged to make the object-glass visible by means of a lantern so constructed as to throw the rays of light up to it in a parallel direction.—In making such observations they must

have taken incredible pains, endured much cold and fatigue and subjected themselves to very great labor and expense—which almost makes us wonder at the discoveries they were instrumental in bringing to light—and should make modern philosophers sensible of the obligations they are under to such men as Newton and Dollond, through whose inventions such unwieldy instruments are no longer necessary. Telescopes of the description now stated were made of all sizes, from 30 to above 120 feet in length. Divini at Rome, and Campani at Bologna, were famed as makers of the object-glasses of the long focal distance to which we have alluded, who sold them for a great price, and took every method to keep the art of making them a secret. It was with telescopes made by Campani that Cassini made his discoveries. They were made by the express order of Louis XIV, and were of 86, 100, and 136 Paris feet in focal length. M. Azout made one object-glass of 600 feet focus; but he was never able to manage it so as to make any practical observations with it. Hartsocker is said to have made some of a still greater focal length. The famous aerial telescope of Huygens was 123 feet in focal length, with six inches of aperture. At his death he bequeathed it to the Royal Society of London, in whose possession it still remains. It required a pole of more than a hundred feet high on which to place the object-glass for general observations. It was with this glass that Dr. Derham made the observations to which he alludes in his preface to his "Astronomy." When this glass was in the possession of Mr. Cavendish, it was compared with one of Mr. Dollond's forty-six inch triple object-glass achromatics, and the gentlemen who were present at the trial, said that "the Dwarf was fairly a

match for the Giant." It magnified 218 times, and the trouble of managing it was said to be extremely tiresome and laborious.

SECTION IV.

THE COMMON REFRACTING TELESCOPE FOR TERRESTRIAL OBJECTS.

This telescope is constructed on the same principle as the astronomical telescope already described, with the addition of two or three glasses. In fig. 47, *OB* represents a distant object, *LN* the object-glass, which forms the image *IM* in its focus, which is, of course, in an inverted position, and, if the eye were applied to the lens *EE*, the object would appear exactly as through the astronomical telescope, every object being apparently turned upside down. To remedy this inconvenience, there are added two other glasses, *FF* and *GG*, by which a second image is formed from the first, in the same position as the object. In order to effect this, the first of these two glasses, namely, *FF*, is placed at twice its focal distance from the former glass, *EE*, and the other lens, *GG*, next the eye, is placed at the same distance from *FF*; for all the three glasses are supposed to be of the same focal distance.— Now the lens *FF*, being placed at twice the focal distance for parallel rays from *EE*, receives the pencils of parallel rays after they have crossed each other at *X*, and forms an image at *im* similar to that at *IM*, and equal to it, but contrary in position, and consequently erect; which last image is viewed by the lens *GG*, in the same manner as the first image, *IM*, would be viewed by the lens *EE*. In this case the image *IM* is considered as an object to the lens *FF*, of which it forms a picture in its focus, in a reverse position from that of the first image, and, of course, in the same position as the object.

The magnifying power of this telescope is determined precisely in the same way as that of the astronomical telescope. Suppose the object-glass to be thirty inches focal distance, and each of the eye-glasses  $1\frac{1}{2}$  inch focal distance, the magnifying power is in the proportion of 30 to  $1\frac{1}{2}$ , or 20 times, and the instrument is, of course, considerably longer than an astronomical telescope of the same power. The distance, in this case, between the object-glass and the first eyeglass, *EE*, is  $31\frac{1}{2}$  inches; the distance between *EE* and the second glass, *FF*, is 3 inches, and the distance between *FF* and the glass *GG*, next the eye, 3 inches; in all,  $37\frac{1}{2}$  inches, the whole length of the telescope. Although it is usual to make use of three eyeglasses in this telescope, yet two will cause the object to appear erect, and of the same magnitude. For, suppose the middle lens, *FF*, taken away, if the first lens, *EE*, be placed at *X*, which is double its focal distance from the image, *IM*, it will, at the same distance, *Xm*, on the other side, form a secondary image, *im*, equal to the primary image *IM*, and also in a contrary position. But such a combination of eyeglasses produces a great degree of coloring in the image, and therefore is seldom used. Even the combination now described, consisting of three lenses of equal focal distances, is now almost obsolete, and has given place to a much better arrangement, consisting of four glasses of different focal distances, which shall be afterward described.

The following figures, 48, 49, 50, represent the

manner in which the rays of light are refracted through the glasses of the telescopes we have now described. Fig. 48 represents the ray of light as they pass from the object to the eye in the Galilean telescope. After passing in a parallel direction to the object-glass, they are refracted by that glass, and undergo a slight convergence in passing toward the concave eyeglass, where they enter the eye in a parallel direction, but no image is formed previous to their entering the eye until they arrive at the retina. Fig. 49 represents the rays as they pass through the glasses of the astronomical telescope. The rays, after entering the object-glass, proceed in a converging direction until they arrive at its focus about *A*, where an image of the object is formed; they then proceed diver-

Fig. 47.

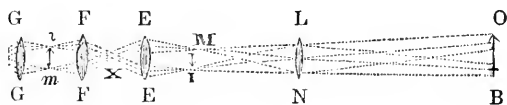

ing to the eyeglass, where they are rendered parallel, and enter the eye in that direction. Fig. 50 represents the rays as they converge and diverge in passing through the four glasses of the common day telescope, described above. After passing through the object-glass, they converge

Fig. 48. Fig. 49. Fig. 50.

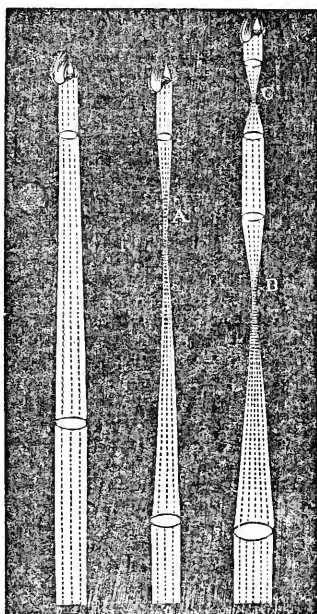

toward *B*, where the first image is formed. They then diverge toward the first eyeglass, where they are rendered parallel, and, passing through the second eyeglass, they again converge and form a second image at *C*, from which point they again diverge, and, passing through the first eyeglass, enter the eye in a parallel direction. If the glasses of these telescopes were fixed on long pieces of wood, at their proper distances from each other, and placed in a darkened room, when

the sun is shining, the beam of the sun's light would pass through them in the same manner as here represented.

## SECTION V.

### TELESCOPE FORMED BY A SINGLE LENS.

This is a species of telescope altogether unnoticed by optical writers, so far as I know; nor has the property of a single lens, in magnifying distant objects, been generally adverted to or recognized. It may not, therefore, be inexpedient to state a few experiments which I have made in relation to this point. When we hold a spectacle-glass of a pretty long focal distance—say from 20 to 24 inches—close to the eye, and direct it to distant objects, they do not appear sensibly magnified.—But if we hold the glass about 12 or 16 inches from our eye, we shall perceive a sensible degree of magnifying power, as if distant objects were seen at less than half the distance at which they are placed. This property of a spectacle-glass I happened to notice when a boy, and on different occasions since that period have made several experiments on the subject, some of which I shall here relate.

With the object-glass of a common refracting telescope,  $4\frac{1}{2}$  feet focal distance, and  $2\frac{1}{2}$  inches diameter, I looked at distant objects—my eye being at about  $3\frac{1}{2}$  feet from the lens, or about 10 or 12 inches within its focus—and it produced nearly the same effect as a telescope which magnifies the diameters of objects 5 or 6 times. With another lens, 11 feet focal distance and 4 inches diameter, standing from it at the distance of about ten feet, I obtained a magnifying power of about 12 or 14 times, which enabled me to read the letters on the signposts of a village half a mile distant.—Having some time ago procured a very large lens, 26 feet focal distance and  $11\frac{1}{2}$  inches diameter, I have tried with it various experiments of this kind upon different objects. Standing at the distance of about 25 feet from it, I can see distant objects through it magnified about 26 times in diameter, and consequently 676 times in surface, and remarkably clear and distinct, so that I can distinguish the hour and minute hands of a public clock in a village two miles distant. This single lens, therefore, answers the purpose of an ordinary telescope with a power of 26 times. In making such experiments, our eye must always be *within* the focus of the lens, at least 8 or 10 inches. The object will, indeed, be seen at any distance from the glass within this limit, but the magnifying power is diminished in proportion as we approach nearer to the glass. Different eyes, too, will require to place themselves at different distances, so as to obtain the greatest degree of magnifying power with distinctness, according as individuals are long or shortsighted.

This kind of telescope stands in no need of a tube, but only of a small pedestal on which it may be placed on a table, nearly at the height of the eye, and that it be capable of a motion in a perpendicular or parallel direction, to bring it in a line with the eye and the object. The principle on which the magnifying power in this case is produced, is materially the same as that on which the Galilean telescope depends. The eye of the observer serves instead of the concave lens in that instrument; and as the concave lens is placed as much within the focus of the object-glass as is equal to its own focal distance, so the eye, in

these experiments, must be placed at least its focal distance within the focus of the lens with which we are experimenting; and the magnifying power will be nearly in the proportion of the focal distance of the lens to the focal distance of the eye. If, for example, the focal distance of the eye, or the distance at which we see to read distinctly, be 10 inches, and the focal distance of the lens 11 feet, the magnifying power will be as 11 feet, or 132 inches to 10, that is, about 13 times. Let *A* (fig. 51) represent the lens placed on a pedestal; the

Fig. 51.

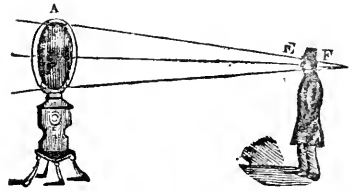

rays of light passing through this lens from distant objects will converge toward a focus at *F*.—If a person then place his eye at *E*, a certain distance within the focal point, he will see distant objects magnified nearly in the proportion of the focal distance of the lens to that of the eye; and when the lens is very broad—such as the 26 feet lens mentioned above—two or three persons may look through it at once, though they will not all see the same object. I have alluded above to a lens made by M. Azout of 600 feet focal distance. Were it possible to use such a lens for distant objects, it might represent them as magnified 5 or 600 times, without the application of any eyeglass. In this way the aerial telescope of Huygens would magnify objects above 100 times, which is about half the magnifying power it produced with its eyepiece. Suppose Azout's lens had been fitted up as a telescope, it would not have magnified above 480 times, as it would have required an eyeglass of 14 or 15 inches focal distance, whereas, without an eyeglass, it would have magnified objects considerably above 500 times. It is not unlikely that the species of telescope to which I have now adverted constituted one of those instruments for magnifying distant objects which were said to have been in the possession of certain persons long before their invention in Holland, and by Galileo in Italy, to which I have referred in p. 55. Were this kind of telescope to be applied to the celestial bodies, it would require to be elevated upon a pole in the manner represented in fig. 45, p. 66.

## SECTION VI.

### THE ACHROMATIC TELESCOPE.

This telescope constitutes the most important and useful improvement ever made upon telescopic instruments, and it is probable it will ere long supersede the use of all other telescopes. Its importance and utility will at once appear when we consider that a good achromatic telescope of only 4 or 5 feet in length will bear a magnifying power as great as that of a common astronomical telescope 100 feet long, and even with a greater degree of distinctness, so that they are now come into general use both for terrestrial and celestial observations. There are, indeed, certain obstructions which prevent their being made of a very

large size; but from the improvement in the manufacture of achromatic glass which is now going forward, it is to be hoped that the difficulties which have hitherto impeded the progress of opticians will soon be removed. In order to understand the nature of this telescope, it will be necessary to advert a little to the imperfections connected with the common refracting telescopes.

The first imperfection to which I allude is this, that *spherical surfaces do not refract the rays of light accurately to a point*; and hence the image formed by a single convex lens is not perfectly accurate and distinct. The rays which pass near the extremities of such a lens meet in foci nearer to the lens than those which pass nearly through the center, which may be illustrated by the following figure: Let  $P P$  (fig. 52) be a convex lens, and  $E e$ , an object, the point  $E$  of which

Fig. 52.

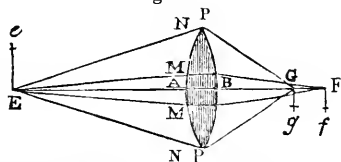

corresponds with the axis, and sends forth the rays  $EM, EN, EA, \&c.$ , all of which reach the surface of the glass, but in different parts. It is manifest that the ray  $EA$ , which passes through the middle of the glass, suffers no refraction. The rays  $EM, EN$ , likewise, which pass through near to  $EA$ , will be converged to a focus at  $F$ , which we generally consider as the focus of the lens. But the rays  $EN, EN$ , which are nearer to the edge of the glass, will be differently refracted, and will meet about  $G$ , nearer to the lens, where they will form another image  $Gg$ . Hence it is evident that the first image,  $Ff$ , is formed only by the union of those rays which pass very near the center of the lens; but as the rays of light proceeding from every point of an object are very numerous, there is a succession of images formed, according to the parts of the lens where they penetrate, which necessarily produces indistinctness and confusion. This is the imperfection which is distinguished by the name of *spherical aberration*, or the error arising from the spherical form of lenses.

The second and most important imperfection of single lenses, when used for the object-glasses of telescopes, is, that the rays of compounded light being differently refrangible, come to their respective foci at different distances from the glass; the more refrangible rays, as the *violet*, converging sooner than those which are less refrangible, as the *red*. I have had occasion to illustrate this circumstance, when treating on the colors produced by the prism (see p. 42, and figures 32 and 33), and it is confirmed by the experiment of a paper painted red, throwing its image, by means of a lens, at a greater distance than another paper painted blue. From such facts and experiments, it appears that the image of a white object consists in an indefinite number of colored images, the violet being nearest, and the red farthest from the lens, and the images of intermediate colors at intermediate distances. The aggregate, or image itself, must therefore be in some degree confused; and this confusion being much increased by the magnifying power, it is found necessary to use an eyeglass of a certain limited convexity to a given object-glass. Thus, an object-glass of 34 inches focal length will bear an eyeglass of only one

inch focus, and will magnify the diameters of objects 34 times; one of 50 feet focal distance will require an eyeglass of  $4\frac{1}{2}$  inches focus, and will magnify only 142 times; whereas, could we apply to it an eyeglass of only one inch focus, as in the former case, it would magnify no less than 600 times. And were we to construct an object glass of 100 feet focal length, we should require to apply an eyeglass not less than six inches focus, which would produce a power of about 200 times; so that there is no possibility of producing a great power by single lenses without extending the telescope to an immoderate length.

Sir Isaac Newton, after having made his discoveries respecting the colors of light, considered the circumstance we have now stated as an insuperable barrier to the improvement of refracting telescopes, and therefore turned his attention to the improvement of telescopes by *reflection*. In the telescopes which he constructed and partly invented, the images of objects are formed by reflection from speculums or mirrors; and being free from the irregular convergency of the various colored rays of light, will admit of a much larger aperture and the application of a much greater degree of magnifying power. The reflector which Newton constructed was only six inches long, but it was capable of bearing a power equal to that of a six feet refractor. It was a long time, however, after the invention of these telescopes, before they were made of a size fitted for making celestial observations. After reflecting telescopes had been some time in use, Dollond made his famous discovery of the principle which led him to the construction of the *achromatic telescope*. This invention consists of a compound object-glass formed of two different kinds of glass, by which both the spherical aberration and the errors arising from the different refrangibility of the rays of light are in a great measure corrected. For the explanation of the nature of this compound object-glass and the effects it produces, it may be expedient to offer the following remarks respecting the dispersion of light and its refraction by different substances.

The *dispersion* of light is estimated by the variable angle formed by the red and violet rays which bound the solar spectrum, or, rather, it is the excess of the refraction of the most refrangible ray above that of the least refrangible ray. The dispersion is not proportional to the refraction, that is, the substances which have an equal mean refraction do not *disperse* light in the same ratio. For example, if we make a prism with plates of glass, and fill it with oil of cassia, and adjust its refracting angle,  $ACB$  (fig. 31, p. 42), so that the middle of the spectrum which it forms falls exactly at the same place where the green rays of a spectrum formed by a glass prism would fall, then we shall find that the spectrum formed by the *oil of cassia* prism will be two or three times *longer* than that of the *glass* prism. The oil of cassia, therefore, is said to *disperse* the rays of light more than the glass, that is, to separate the extreme red and violet rays at  $O$  and  $P$  more than the mean ray at *green*, and to have a greater *dispersive power*. Sir I. Newton appears to have made use of prisms composed of different substances, yet, strange to tell, he never observed that they formed spectrums whose lengths were different when the refraction of the green ray was the same, but thought that the dispersion was proportional to the refraction. This error continued to be overlooked by philosophers for a considerable time, and was the cause of retarding the invention of the achromatic telescope for more than 50 years.

Dollond was among the first who detected this error. By his experiments it appears that the different kinds of glass differ extremely with respect to the divergency of colors produced by equal refractions. He found that two prisms, one of white flint glass, whose refracting angle was about 25 degrees, and another of crown glass, whose refracting angle was about 29 degrees, refracted the beam of light nearly alike, but that the divergency of color in the white flint was considerably more than in the crown glass; so that when they were applied together, to refract contrary ways, and a beam of light transmitted through them, though the emergent continued parallel to the incident part, it was, notwithstanding, separated into component colors. From this he inferred that, in order to render the emergent beam white, it is necessary that the refracting angle of the prism of crown glass should be *increased*, and by repeated experiments he discovered the exact quantity. By these means he obtained a theory in which refraction was performed without any separation or divergency of color, and thus the way was prepared for applying the principle he had ascertained to the construction of the object-glasses of refracting telescopes. For the edges of a convex and concave lens, when placed in contact with each other, may be considered as two prisms which refract contrary ways; and if the excess of refraction in the one be such as precisely to destroy the divergency of color in the other, a colorless image will be formed. Thus, if two lenses are made of the same focal length, the one of flint glass and the other of crown, the length or diameter of the colored image in the first will be to that produced by the crown glass as three to two nearly. Now if we make the focal lengths of the lenses in this proportion, that is, as three to two, the colored spectrum produced by each will be equal. But if the flint lens be concave, and the crown convex, when placed in contact they will mutually correct each other, and a pencil of white light refracted by the compound lens will remain colorless.

The following figure may perhaps illustrate what has been now stated. Let  $LL$  (fig. 53) represent a convex lens of crown glass, and  $ll$  a

Fig. 53.

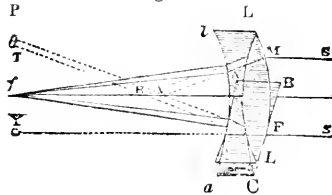

concave lens of flint glass. A ray of the sun,  $S$ , falls at  $F$  on the convex lens, which will refract it exactly as the prism  $ABC$ , whose faces touch the two surfaces of the lens at the points where the ray enters and quits it. The solar ray,  $SF$ , thus refracted by the lens  $LL$ , or prism  $ABC$ , would have formed a spectrum  $PT$ , on the wall, had there been no other lens, the violet ray,  $F$ , crossing the axis of the lens at  $V$ , and going to the upper end,  $P$ , of the spectrum; and the red ray,  $F'R$ , going to the lower end,  $T$ . But as the flint glass lens  $ll$ , or the prism  $aAC$ , which receives the rays  $FV, FR$ , at the same points, is interposed, these rays will be united at  $f$ , and form a small circle of white light; the ray  $SF$  of the sun being now refracted without color from its primitive direction  $SFY$  into the new direction

$Ff$ . In like manner, the corresponding ray  $SM$  will be refracted to  $f$ , and a white and colorless image of the sun will be there formed by the two lenses. In this combination of lenses, it is obvious that the spherical aberration of the flint lens corrects to a considerable degree that of the crown glass, and by a proper adjustment of the radii of the surfaces, it may be almost wholly removed. This error is still more completely corrected in the triple achromatic object-glass, which consists of three lenses—a concave flint lens placed between convexes of crown glass. Fig. 54 shows the double achromatic lens, and fig. 55 the triple object-glass, as they are fitted up in their cells, and placed at the object end of the telescope. In

Fig. 54.

Fig. 55.

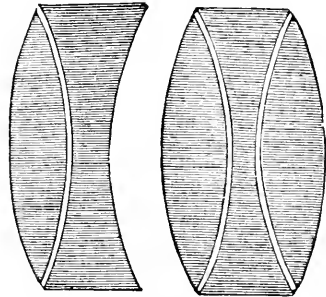

consequence of their producing a focal image free of color, they will bear a much larger aperture and a much greater magnifying power than common refracting telescopes of the same length. While a common telescope whose object-glass is  $2\frac{1}{2}$  feet focal distance will bear an aperture of scarcely one inch, the  $3\frac{1}{2}$  feet achromatic will bear an aperture of  $3\frac{1}{4}$  inches, and consequently transmits  $10\frac{1}{2}$  times the quantity of light. While the one can bear a magnifying power of only about 36 times, the other will bear a magnifying power for celestial objects of more than 200 times.

The theory of the achromatic telescope is somewhat complicated and abstruse, and would require a more lengthened investigation than my limits will permit. But what has been already stated may serve to give the reader a general idea of the principle on which it is constructed, which is all I intended. The term *achromatic*, by which such instruments are now distinguished, was first given to them by Dr. Bevis. It is compounded of two Greek words which signify "free of color." And were it not that even philologists are not altogether free of that pedantry which induces us to select Greek words which are unintelligible to the mass of mankind, they might have been contented with selecting the plain English word *colorless*, which is as significant and expressive as the Greek word *achromatic*. The *crown glass*, of which the convex lenses of this telescope are made, is the same as good common window glass; and the *flint glass* is that species of glass of which wine-glasses, tumblers, decanters, and similar articles are formed, and is sometimes distinguished by the name of crystal glass. Some opticians have occasionally formed the concave lens of an achromatic object-glass from the bottom of a broken tumbler.

This telescope was invented and constructed by Mr. John Dollond, about the year 1758. When he began his researches into this subject, he was a silk weaver in Spitalfields, London. The attempt of the celebrated Euler to form a colorless tele-

scope, by including water between two meniscus glasses, attracted his attention, and in the year 1753 he addressed a letter to Mr. Short, the optician, which was published in the Philosophical Transactions of London, "concerning a mistake in Euler's theorem for correcting the aberrations in the object-glasses of refracting telescopes." After a great variety of experiments on the refractive and dispersive powers of different substances, he at last constructed a telescope in which an exact balance of the opposite dispersive powers of the crown and flint lenses made the colors disappear, while the predominating refraction of the crown lens disposed the achromatic rays to meet at a distant focus. In constructing such object-glasses, however, he had several difficulties to encounter. In the first place, the focal distance as well as the particular surfaces must be very nicely proportioned to the densities or refractive powers of the glasses, which are very apt to vary in the same sort of glass made at different times. In the next place, the centers of the two glasses must be placed truly in the common axis of the telescope, otherwise the desired effect will be in a great measure destroyed. To these difficulties is to be added, that there are four surfaces (even in double achromatic object-glasses) to be wrought perfectly spherical; and every person practiced in optical operations will allow that there must be the greatest accuracy throughout the whole work. But these and other difficulties were at length overcome by the judgment and perseverance of this ingenious artist.

It appears, however, that Dollond was not the only person who had the merit of making this discovery—a private gentleman, Mr. Chest, of Chest Hall, a considerable number of years before, having made a similar discovery, and applied it to the same purpose. This fact was ascertained in the course of a process raised against Dollond, at the instance of Watkins, optician at Charing Cross, when applying for a patent. But as the other gentleman had kept his invention a secret, and Dollond had brought it forth for the benefit of the public, the decision was given in his favor. There was no evidence that Dollond borrowed the idea from his competitor, and both were, to a certain extent, entitled to the merits of the invention.

One of the greatest obstructions to the construction of large achromatic telescopes is the difficulty of procuring large discs of flint glass of a uniform refractive density, of good color, and free from veins. It is said that fortunately for Mr. Dollond, this kind of glass was procurable when he began to make achromatic telescopes, though the attempts of ingenious chemists have since been exerted to make it without much success. It is also said that the glass employed by Dollond in the fabrication of his best telescopes was of the same melting, or made at the same time, and that, excepting this particular treasure, casually obtained, good dense glass for achromatic purposes was always as difficult to be procured as it is now. The dispersion of the flint glass, too, is so variable, that, in forming an achromatic lens, trials on each specimen require to be made before the absolute proportional dispersion of the substances can be ascertained. It is owing, in a great measure, to these circumstances that a large and good achromatic telescope cannot be procured unless at a very high price. Mr. Tulley, of Islington—who has been long distinguished as a maker of excellent achromatic instruments—showed me, about six years ago, a rude piece of flint glass about five inches diameter, intended for the concave lens of an achromatic object-glass, for which he paid eight

guineas. This was before the piece of glass was either figured or polished, and, consequently, he had still to perform the delicate operation of figuring, polishing, and adjusting this concave to the convex lenses with which it was to be combined; and, during the process, some veins or irregularities might be detected in the flint glass which did not then appear. Some years before, he procured a disc of glass from the Continent, about seven or eight inches diameter, for which he paid about thirty guineas, with which an excellent telescope, twelve feet focal length, was constructed for the Astronomical Society of London. It is obvious, therefore, that large achromatic telescopes must be charged at a pretty high price.

In order to stimulate ingenious chemists and opticians to make experiments on this subject, the Board of Longitude, more than half a century ago, offered a considerable reward for bringing the art of making good flint glass for optical purposes to the requisite perfection. But considerable difficulties arise in attempting improvements of this kind, as the experiments must all be tried on a very large scale, and are necessarily attended with a heavy expense; and, although government has been extremely liberal in voting money for warlike purposes, and in bestowing pensions on those who stood in no need of them, it has thrown an obstruction in the way of such experiments, by the heavy duty of excise, which is rigorously exacted, whether the glass be manufactured into saleable articles or not, and has thus been instrumental in retarding the progress of improvement and discovery. It would appear that experiments of this kind have been attended with more success in France, Germany, and other places on the Continent than in Britain, as several very large achromatic telescopes have been constructed in those countries by means of flint glass, which was cast for the purpose in different manufactories, and to which British artists have been considerably indebted, as the London opticians frequently purchase their largest discs of flint glass from Parisian agents. Guinaud, a Continental experimenter, and who was, originally a cabinetmaker, appears to have had his labors in this department of art crowned with great success. Many years were employed in his experiments, and he too frequently, notwithstanding all his attention, discovered his metal to be vitiated by striae, specks, or grains, with cometic tails. He constructed a furnace capable of melting two *cwt.* of glass in one mass, which he sawed vertically, and polished one of the sections, in order to observe what had taken place during the fusion. From time to time, as he obtained blocks including portions of good glass, his practice was to separate them by sawing the blocks into horizontal sections, or perpendicular to their axes. A fortunate accident conducted him to a better process. While his men were one day carrying a block of this glass on a handbarrow to a sawmill which he had erected at the Fall of the Doubs, the mass slipped from its bearers, and rolling to the bottom of a steep and rocky declivity, was broken to pieces. Guinaud having selected those fragments which appeared perfectly homogeneous, softened them in circular molds in such a manner, that, on cooling, he obtained discs that were afterward fit for working. To this method he adhered, and contrived a way for clearing his glass while cooling, so that the fractures should follow the most faulty parts. When flaws occurred in the large masses, they were removed by cleaving the pieces with wedges; then smelting them again in molds, which gave them the form of discs. The Astronomical Society of London

have made trial of those made by Guinaud, and have found them entirely homogeneous and free from fault. Of this ingenious artist's flint glass some of the largest achromatic telescopes on the Continent have been constructed. But it is more than twenty years since this experimenter took his flight from this terrestrial scene, and it is uncertain whether his process is carried on with equal success.

NOTICES OF SOME LARGE ACHROMATIC TELESCOPES ON THE CONTINENT AND IN GREAT BRITAIN.

1. *The Dorpat Telescope.*—This is one of the largest and most expensive refracting telescopes ever constructed. It was made by the celebrated Fraunhofer, of Munich, for the observatory of the Imperial University of Dorpat, and was received into the observatory by Professor Struve, in the year 1825. The aperture of the object-glass of this telescope is  $9\frac{1}{2}$  English inches, and its solar focal length about 14 feet, the main tube being 13 French feet, exclusive of the tube which holds the eyepieces. The smallest of the four magnifying powers it possesses is 175, and the largest 700, which, in favorable weather, is said to present the object with the utmost precision. "This instrument," says Struve, "was sold to us by Privy-counsellor Von Utzschneider, the chief of the optical establishment at Munich, for 10,500 florins (about £950 sterling), a price which only covers the expenses which the establishment incurred in making it." The framework of the stand of this telescope is of oak, inlaid with pieces of mahogany in an ornamental manner, and the tube is of deal veneered with mahogany and highly polished. The whole weight of the telescope and its counterpoises is supported at one point, at the common center of gravity of all its parts; and though these weigh 3000 Russian pounds, yet we are told that this enormous telescope may be turned in every direction toward the heavens with more ease and certainty than other hitherto in use. When the object-end of the telescope is elevated to the zenith, it is sixteen feet four inches Paris measure, above the floor, and its eye-end in this position is two feet nine inches high. This instrument is mounted on an equatorial stand, and clockwork is applied to the equatorial axis, which gives it a smooth and regular sidereal motion, which, it is said, keeps a star in the exact center of the field of view, and produces the appearance of a state of rest in the starry regions, which motion can be made solar, or even lunar, by a little change given to the place of a pointer that is placed as an index on the dial plate. Professor Struve considers the optical powers of this telescope superior to those of Schroeter's twenty-five feet reflector, from having observed  $\alpha$  Orionis with fifteen companions, though Schroeter observed only twelve that he could count with certainty. Nay, he seems disposed to place it in competition with the late Sir W. Herschel's forty-foot reflector. The finder of this telescope has a focal distance of 30 French inches, and 2-42 aperture.

2. *Sir James South's Telescope.*—About the year 1829, Sir J. South, President of the London Astronomical Society, procured of M. Cauchoix, of Paris, an achromatic object-glass of 11 2-10 inches clear aperture, and of 19 feet focal length. The flint glass employed in its construction was the manufacture of the late Guinaud le Pere, and was found to be absolutely perfect. The first observation was made with this telescope while on a temporary stand, on Feb. 13, 1830, when Sir J.

Herschel discovered with it a sixth star in the trapezium in the nebula of Orion, whose brightness was about one-third of that of the fifth star discovered by Struve, which is as distinctly seen as the companion to Polaris is in a five feet achromatic. Sir James gives the following notices of the performance of this instrument on the morning of May 14, 1830. "At half past two placed the 29 feet achromatic on the Georgium Sidus, saw it with a power of 346, a beautiful planetary disc; not the slightest suspicion of any ring, either perpendicular or horizontal; but the planet three hours east of the meridian, and the moon within three degrees of the planet. At a quarter before three, viewed Jupiter with 252 and 346, literally covered with belts, and the diameters of his satellites might have been as easily measured as himself. One came from behind the body, and the contrast of the color with that of the planet's limb was striking. At three o'clock viewed Mars. The contrast of light in the vicinity of the poles very decided. Several spots on his body well and strongly marked; that about the south pole seems to overtake the body of the planet, and gives an appearance not unlike that afforded by the new moon, familiarly known as 'the old moon in the moon's arms.'" Saturn has been repeatedly seen with powers from 130 to 928, under circumstances the most favorable; but not anything anomalous about the planet or its ring could even be suspected. This telescope is erected on an equatorial stand, at Sir J. South's observatory, Kensington.

3. *Captain Smith's Telescope in his private observatory at Bedford.*—This achromatic telescope is  $8\frac{1}{2}$  feet focal length, with a clear aperture of 5 9-10 inches, worked by the late Mr. Tulley, senior, from a disc purchased by Sir James South at Paris. It is considered by Captain Smith to be the finest specimen of that eminent optician's skill, and, it is said, will bear with distinctness a magnifying power of 1200. Its distinctness has been proved by the clear vision it gives of the obscure nebulae, and of the companions of Polaris, Rigel,  $\alpha$  Lyrae, and the most minute double stars—the lunar mountains, cavities, and shadows under all powers—the lucid polar regions of Mars—the sharpness of the double ring of Saturn—the gibbous aspect of Venus—the shadows of Jupiter's satellites across his body, and the splendid contrast of colors in  $\alpha$  Hercules,  $\gamma$  Andromeda, and other superb double stars.

*Other large Achromatics.*—Beside the above, the following, belonging to public observatories and private individuals, may be mentioned. In the Royal Observatory at Greenwich there is an achromatic of 10 feet focal distance, having a double object-glass 5 inches diameter, which was made by Mr. Peter Dollond, and the only one of that size he ever constructed. There is also a 46 inch achromatic, with a triple object-glass  $32\frac{1}{4}$  inches aperture, which is said to be the most perfect instrument of the kind ever produced. It was the favorite instrument of Dr. Maskelyne, late astronomer royal, who had a small room fitted up in the observatory for this telescope. The observatory some years ago erected near Cambridge is, perhaps the most splendid structure of the kind in Great Britain. It is furnished with several very large achromatic telescopes on equatorial machinery; but the achromatic telescope lately presented to it by the Duke of Northumberland is undoubtedly the largest instrument of this description which is to be found in this country. The object-glass is said to be twenty-five feet focal distance, and of a corresponding diameter;



but as there was no access to this instrument at the time I visited the observatory, nearly six years ago, I am unable to give a particular description of it. In the Royal Observatory at Paris, which I visited in 1837, I noticed, among other instruments, two very large achromatic telescopes, which, measuring them rudely by the eye, I estimated to be from 15 to 18 feet long, and the aperture at the object-end from 12 to 15 inches diameter. They were the largest achromatics I had previously seen; but I could find no person in the Observatory at that time who could give me any information as to their history, or to their exact dimensions or powers of magnifying.\*

The Rev. Dr. Pearson, treasurer to the Astronomical Society of London, is in possession of the telescope formerly alluded to made by Mr. Tulley, of twelve feet focal distance and seven inches aperture, which is said to be a very fine one. The small star which accompanies the pole-star, with a power of 100, appears through this telescope as distinct and steady as one of Jupiter's satellites. With a single lens of 6 inches focus, which produced a power of 24 times, according to the testimony of an observer who noticed it, the small star appeared as it does in an achromatic of three inches aperture, which shows the great effect of illuminating power in such instruments. Mr. Lawson a diligent astronomical observer in Hereford, possesses a most beautiful achromatic telescope of about 7 inches aperture and 12 feet focal distance, which was made by one of the Dollands, who considered it his *chef d'œuvre*. It is said to bear powers as high as 1100 or 1400, and has been fitted up with mechanism, devised by Mr. Lawson himself, so as to be perfectly easy and manageable to the observer, and which displays this gentleman's inventive talent. In several of his observations with this instrument, he is said to have had a view of some of the more minute subdivisions of the ring of Saturn. A very excellent achromatic telescope was fitted up some years ago by my worthy friend William Bridges, Esq., Blackheath. Its object-glass is 5½ inches diameter, and about 5½ feet focal length. It is erected upon equatorial machinery, and placed in a circular observatory which moves round with a slight touch of the hand. The object-glass of this instrument cost about 200 guineas; the equatorial machinery on which it is mounted cost 150 guineas; and the circular observatory in which it is placed about 100 guineas, in all 450 guineas. Its powers vary from 50 to 300 times.†

#### ACHROMATIC TELESCOPES OF A MODERATE SIZE.

Such telescopes as I have alluded to above are among the largest which have yet been made on the achromatic principle; they are, of course, comparatively rare, and can be afforded only at a very high price. Few of the *object-glasses* in the telescopes to which I have referred would be valued at less than 200 guineas, independently of the tubes, eyepieces, and other apparatus with which they are fitted up. It is so difficult to pro-

cure large discs of flint glass for optical purposes, to produce the requisite curves of the different lenses, and to combine them together with that extreme accuracy which is requisite, that, when a good compound lens of this description is found perfectly achromatic, the optician must necessarily set a high value upon it, since it may happen that he may have finished half a dozen before he has got one that is nearly perfect. The more common sizes of achromatic telescopes for astronomical purposes, which are regularly sold by the London opticians, are the following:

1. *The 2½ feet Achromatic.*—This telescope has an object-glass 30 inches in focal length, and 2 inches clear aperture. It is generally furnished with two eyepieces, one, for terrestrial objects, magnifying about 30 or 35 times, and one for celestial objects, with a power of 70 or 75 times. It might be furnished with an additional astronomical eyepiece, if the object-glass be a good one, so as to produce a power of 90 or 95 times. With such a telescope the belts and satellites of Jupiter, the phases of Venus, and the ring of Saturn may be perceived, but not to so much advantage as with larger telescopes. It is generally fitted up either with a mahogany or a brass tube, and is placed upon a tripod brass stand, with a universal joint which produces a horizontal and vertical motion. It is packed, along with the eyepieces and whatever else belongs to it, in a neat mahogany box. Its price varies according as it is furnished with an elevating rack or other apparatus.

The following are the prices of this instrument, as marked in the catalogue of Mr. Tulley, Terrett's Court, Islington, London.

	<i>£</i>	<i>s.</i>	<i>d.</i>
2½ feet telescopes, brass mounted on plain pillar and claw stand, with 1 eyepiece for astronomical purposes and 1 for land objects, to vary the magnifying power, packed in a mahogany box		10	10 0
Ditto, ditto, brass mounted on pillar and claw stand, with elevating rack, 1 eyepiece for astronomical purposes, and 1 for land objects, to vary the magnifying power, packed in a mahogany box		12	12 0

The following prices of the same kind of telescopes are from the catalogue of Messrs. W. and S. Jones, 30 Lower Holborn, London.

	<i>£</i>	<i>d.</i>	<i>s.</i>
The improved 2½ feet achromatic refractor, on a brass stand, mahogany tube, with three eyepieces, two magnifying about 40 and 50 times for terrestrial objects, and the other about 75 times for astronomical purposes, in a mahogany case		10	10 0
Ditto, ditto, the tube all brass, with three eyepieces		11	11
Ditto, ditto, with vertical and horizontal rack-work motions		15	15

2. *The 3½ feet Achromatic Telescope.*—The object-glass of this telescope is from 41 to 46 inches focal length, and 2¾ inches diameter. It is generally furnished with four eyepieces, two for terrestrial and two for celestial objects. The lowest power for land objects\* is generally about 45, which affords a large field of view, and exhibits the objects with great brilliancy. The other terrestrial power is usually from 65 to 70. The astronomical powers are about 80 and 130, but such a telescope should always have another

\* An achromatic telescope is said to be in possession of Mr. Cooper, M. P. for Sligo, which is 26 feet long, and the diameter of the object-glass 14 inches.

† This telescope, which was made by Dolland, with a power of 240 times, gives a beautiful view of the belts of Jupiter, and the double ring of Saturn, and with a power of 50 the stars in the Milky Way and some of the nebulae appear very numerous and brilliant. Its owner is a gentleman who unites science with Christianity.

eyepiece, to produce a power of 180 or 200 times, which it will bear with distinctness, in a serene state of the atmosphere, if the object-glass be truly achromatic. The *illuminating power* in this telescope is nearly double that of the  $2\frac{1}{2}$  feet telescope, or in the proportion of 7.56 to 4, and therefore it will bear about double the magnifying power with nearly equal distinctness. This telescope is fitted up in a manner somewhat similar to the former, with a tripod stand which is placed upon a table. Sometimes, however, it is mounted on a long mahogany stand which rests upon the floor (as in fig. 58,) and is fitted with an equatorial motion; and has generally a small telescope fixed near the eye end of the large tube, called a *finder*, which serves to direct the telescope to a particular object in the heavens when the higher powers are applied. It is likewise eligible that it should have an elevating rack and sliding tubes, for supporting the eye end of the instrument, to keep it steady during astronomical observations, and it would be an advantage, for various purposes which shall be afterward described, to have fitted to it a *diagonal eyepiece* magnifying 40 times or upward.

The prices of this instrument, as marked in Mr. Tulley's catalogue, are as follows:

	£	s.	d.
The $3\frac{1}{2}$ feet achromatic telescope, $2\frac{3}{4}$ inches aperture, on plain pillar and claw stand, 2 eyepieces for astronomical purposes and 1 for land objects, to vary the magnifying power, packed in a mahogany box . . . . .	21	0	0
Ditto, ditto, with elevating rack and achromatic finder, 2 eyepieces for astronomical purposes and 1 for day objects, to vary the magnifying power, packed in a mahogany box . . . . .	26	5	0

The following are the prices as marked in Messrs. W. and S. Jones's catalogue:

	£	s.	d.
The $3\frac{1}{2}$ feet achromatic, plain mahogany tube . . . . .	18	18	0
Ditto, ditto, brass tube . . . . .	21	0	0
Ditto, all in brass, with rack-work motions, &c. . . . .	26	5	0
Ditto, the object-glass of the largest aperture, and the rack-work motions on an improved principle, from £37 16s. to . . . . .	42	0	0
Ditto, fitted up with equatorial motion, framed mahogany stand, divided altitude and azimuth arches, or declination and right ascension circles, &c., &c., . . . . . from £60 to	80	0	0

This is the telescope which I would particularly recommend to astronomical amateurs, whose pecuniary resources do not permit them to purchase more expensive instruments. When fitted up with the eyepieces and powers already mentioned, and with a finder and elevating rack—price 25 guineas—it will serve all the purposes of general observation. By this telescope satisfactory views may be obtained of most of the interesting phenomena of the heavens—such as the spots on the sun—the mountains, vales, and caverns on the lunar surface—the phases of Mercury and Venus—the spots on Mars—the satellites and belts of Jupiter—the ring of Saturn—many of the more interesting nebulae, and most of the double stars of the second and third classes. When the object-glass of this telescope is accurately figured and perfectly achromatic, a power of from 200 to 230 may be put upon it, by which the division

of Saturn's ring might occasionally be perceived. It is more easily managed, and represents objects considerably brighter than reflecting telescopes of the same price and magnifying power, and it is not so apt to be deranged as reflectors generally are. A telescope of a less size would not, in general, be found satisfactory for viewing the objects I have now specified, and for general astronomical purposes. It may not be improper, for the information of some readers, to explain what is meant in Mr. Tulley's catalogue, when it is stated that this instrument "has one eyepiece for day objects, to vary the magnifying power." The eyepiece alluded to is so constructed, that by drawing out a tube next the eye you may increase the power at pleasure, and make it to vary say from 40 to 80 or 100 times; so that such a construction of the terrestrial eyepiece (to be afterward explained) serves, in a great measure, the purpose of separate eyepieces. The whole length of the  $3\frac{1}{2}$  feet telescope, when the terrestrial eyepiece is applied, is about  $4\frac{1}{2}$  feet from the object-glass to the first eyeglass.

When the aperture of the object-glass of this telescope exceeds  $2\frac{3}{4}$  inches, its price rapidly advances.

The following is Mr. Tulley's scale of prices, proportionate to the increase of aperture:

	£	s.	d.
$3\frac{1}{2}$ feet telescopes, $3\frac{1}{4}$ inches aperture, with vertical and horizontal rack-work motions, achromatic finder, 3 eyepieces for astronomical purposes, and one for day objects, to vary the magnifying power, packed in a mahogany box . . . . .	42	0	0
Ditto, ditto, $3\frac{3}{4}$ inches diameter, mounted as above . . . . .	68	5	0
Ditto, with universal equatorial instead of pillar and claw stand . . . . .	84	0	0

Here, in the one case, the increase of half an inch in the diameter of the object-glass adds about £16 to the expense, and in the other case no less than £26 5s. The proportion of light in those two telescopes, compared with that of  $2\frac{3}{4}$  inches aperture, is as follows: The square of the  $2\frac{3}{4}$  object-glass is 7.56; that of  $3\frac{1}{4}$ , 10.56; and that of the  $3\frac{3}{4}$ , 14.06; so that the light admitted by the  $3\frac{1}{4}$  compared with the  $2\frac{3}{4}$  aperture is nearly as 10 to 7; and the light admitted by the  $3\frac{3}{4}$  object-glass is nearly double that of the  $2\frac{3}{4}$  aperture, and will bear nearly a proportional increase of magnifying power.

3. *The 5 feet Achromatic Telescope.*—The focal length of the object-glass of this telescope is 5 feet 3 inches, and the diameter of its aperture 3 8-10 inches. The usual magnifying powers applied to it are, for land objects 65 times, and for celestial objects 110, 190, 250, and sometimes one or two higher powers. The quantity of light it possesses is not much larger than that of the  $3\frac{1}{2}$  feet telescope, with  $3\frac{3}{4}$  inches aperture; but the larger focal length of this telescope is considered to be an advantage, since the longer the focus of the object-glass, the less will be its chromatic and spherical aberrations, and the larger may be the eyeglasses, and the flatter the field of view.

The following are the prices of these telescopes, as marked in Mr. Tulley's catalogue:

5 feet telescopes,  $3\frac{3}{4}$  inches aperture, on a universal equatorial stand, with achromatic finder 4 eyepieces for astronomical purposes and 1 for

day objects, to vary the magnifying power, packed in a mahogany box, 100 guineas to

7 feet ditto, 5 inches aperture, on a newly improved universal equatorial stand, 6 eyepieces for astronomical purposes and 1 for day objects, to vary the magnifying power, with achromatic finder and Troughton's micrometer, 207 5 0

The above are all the kinds of achromatic telescopes generally made by the London opticians. Those of the larger kind, as 5 and 7 feet telescopes, and the  $3\frac{1}{2}$  feet with  $3\frac{3}{4}$  inches aperture, are generally made to order, and are not always to be procured. But the  $2\frac{1}{2}$  and  $3\frac{1}{2}$  feet achromatics of  $2\frac{3}{4}$  inches aperture are generally to be found ready made at most of the opticians' shops in the metropolis. The prices of these instruments are nearly the same in most of the opticians' shops in London. Some of them demand a higher price, but few of them are ever sold lower than what has been stated, unless in certain cases where a discount is allowed.

The stands for these telescopes, and the manner in which they are fitted up for observation, is represented in figures 57, 58, and 59. Fig. 57

Fig. 57.

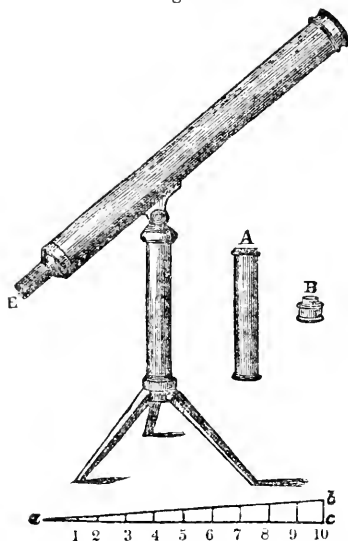

represents either the  $2\frac{1}{2}$  or the  $3\frac{1}{2}$  feet telescopes, mounted on a plain brass stand, to be placed on a table. *A* is the long eyepiece for faint objects, and *B* the small eyepiece for astronomical observation, which is composed of two lenses, and represents the object in an inverted position. These eyepieces are screwed on, as occasion requires, at *E*, the eye end of the telescope. The shorter of the two astronomical eyetubes which accompany this telescope produces the highest magnifying power. For adjusting the telescope to distinct vision, there is a brass knob or button at *a*, which moves a piece of rack-work connected with the eyetube, which must be turned either one way or the other until the object appears distinctly, and different eyes frequently require a different adjustment.

Fig. 58 represents a 5 feet telescope fitted up for astronomical observations. It is mounted on a mahogany stand, the three legs of which are

made to close up together by means of the brass frame *a a a*, which is composed of three bars, connected with three joints in the center, and three other joints, connected with the three mahogany bars. It is furnished with an apparatus

Fig. 58.

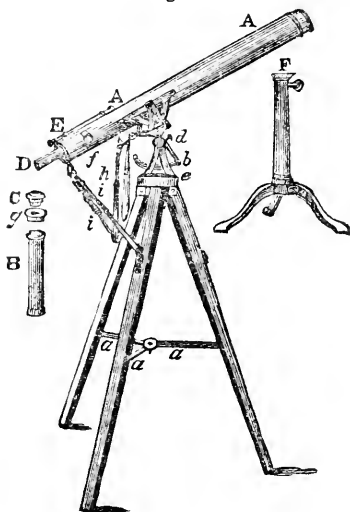

for equatorial motions. The brass pin is made to move round in the brass socket *b*, and may be tightened by means of the finger screw *d*, when the telescope is directed nearly to the object intended to be viewed. This socket may be set perpendicular to the horizon, or to any other required angle; and the quantity of the angle is ascertained by the divided arc, and the instrument made fast in that position by the screw *e*. If this socket be set to the latitude of the place of observation, and the plane of this arc be turned so as to be in the plane of the meridian, the socket *b* being fixed to the inclination of the pole of the earth, the telescope, when turned in this socket, will have an equatorial motion, so that celestial objects may be always kept in view when this equatorial motion is performed. The two handles at *k*, are connected with rack-work, intended to move the telescope in any required direction. The two sets of brass sliding rods, *i i*, are intended to render the telescope as steady as possible, and to elevate and depress it at pleasure, and are so constructed as to slide into each other with the utmost ease.

The finder is placed at *A E*, either on the top or the left side of the tube of the telescope. When high magnifying powers are applied to any telescope, it is sometimes difficult, on account of the smallness of the field of view, to direct the main tube of the telescope to the object. But by the finder, which is a telescope with a small power, and consequently has a large field of view, when directed to any object, it is easily found, and being brought to the center of the field, where two cross-hairs intersect each other, it will then be seen in the larger telescope. *B* is the eyetube for terrestrial objects, containing four glasses, and *C* one of the astronomical eyepieces. A socket is represented at *g*, containing a stained glass, which is screwed to any of the eyepieces, to protect the eye from the glare of light, when viewing the spots of the sun. The brass nut above *f* is intended for the adjustment of the eyepiece to

distinct vision. The 3½ feet telescope is sometimes mounted in this form.

Fig. 59 represents a 5 or 6 feet telescope, mount-

Fig. 59.

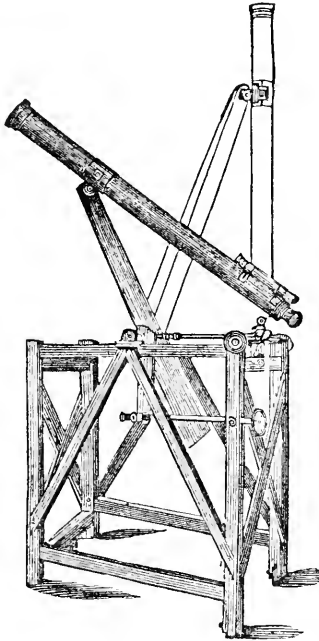

ed on a stand of a new construction by Dollond. It possesses the advantage of supporting the telescope in two places, which renders it extremely steady, a property of great importance when viewing celestial objects with high magnifying powers. It possesses, likewise, the advantage of enabling the observer to continue seated at the same height from the floor, although the telescope be raised to any altitude, *the elevation being entirely at the object end*, although it may be changed from the horizon to the zenith. The framework is composed of bars of mahogany, and rests on three castors, two of which are made fast to their respective legs in the usual way, and the third stands under the middle of the lower horizontal bar that connects the two opposite legs, so that the frame has all the advantages of a tripod. As

it becomes very inconvenient to stoop to the eye end of a telescope when the altitude of an object is considerable, and the center of motion at the middle of the tube, this construction of a stand serves to remedy such inconvenience.

PROPORTIONS OF CURVATURE OF THE LENSES WHICH FORM AN ACHROMATIC OBJECT-GLASS.

As some ingenious mechanics may feel a desire to attempt the construction of a compound achromatic object-glass, I shall here state some of the proportions of curvature of the concave and convex lenses which serve to guide opticians in their construction of achromatic instruments. These proportions are various; and even when demonstrated to be mathematically correct, it is sometimes difficult to reduce them to practice, on account of the different powers of refraction and dispersion possessed by different discs of crown and flint glass, and of the difficulty of producing, by mechanical means, the exact curves which theory requires. The following table shows the radii of curvature of the different surfaces of the lenses necessary to form a *double achromatic object-glass*, it being supposed that the sine of refraction in the crown-glass is as 1.525 to 1, and in the flint as 1.5735 to one, the ratio of their dispersive powers being as 1 to 1.524. It is also assumed that the curvatures of the concave lens are as 1 to 2, that is, that the one side of this lens is ground on a tool, the radius of which is double that of the other. The 1st column expresses the compound focus of the object-glass in inches; the 2d column states the radius of the anterior surface of the *crown*, and column 3d its *posterior* side. Column 4th expresses the radius of the anterior surface of the *concave* lens, and column 5th its posterior surface, which, it will be observed, is exactly double that of the other.

Focus in inches.	Radius of anterior surface, convex.		Radius of posterior surface.		Rad. of anterior surface, concave.		Radius of posterior surface.	
	Inc.	Dec.	Inc.	Dec.	Inc.	Dec.	Inc.	Dec.
12	3		4.	652	4.	171	8.	342
24	6		9.	304	8.	342	16.	684
30	7.	5	11.	63	10.	428	20.	856
36	9		13.	956	12.	513	25.	1027
48	12		18.	608	16.	684	33.	1369
60	15		23.	260	20.	856	41.	1712
120	30		46.	520	41.	1712	83.	3424

From the preceding table it will be seen that, to construct, for example, a 30 inch compound object-glass, the radius of the anterior side of the

Focal length. Inches.	Convex lens of Crown glass.				Concave lens of flint glass.				Convex lens of crown glass.			
	Inc.	Dec.	Inc.	Dec.	Inc.	Dec.	Inc.	Dec.	Inc.	Dec.	Inc.	Dec.
6	4.	54	3.	03	3.	03	6.	36	6.	36	.	64
9	6.	83	4.	56	4.	56	9.	54	9.	54	.	92
12	9.	25	6.	17	6.	17	12.	75	12.	75	1.	28
18	13.	67	9.	12	9.	12	19.	08	19.	08	1.	92
24	18.	33	12.	25	12.	25	25.	50	25.	50	2.	56
30	22.	71	15.	16	15.	16	31.	79	31.	79	3.	20
36	27.	33	18.	25	18.	25	38.	17	38.	17	3.	84
42	31.	87	21.	28	21.	28	44.	53	44.	53	4.	48
48	36.	42	24.	33	24.	33	50.	92	50.	92	6.	12
54	40.	96	27.	36	27.	36	57.	28	57.	28	5.	76
60	45.	42	30.	33	30.	33	63.	58	63.	58	6.	4

crown must be 7½ inches, and that of the posterior side 11.63 inches; the radius of the anterior surface of the concave 10.428, and that of the posterior 20.856 inches. It may be proper to ob-

serve, that in these computations, the radius of the anterior surface of the concave is less than the posterior side of the convex, and consequently admits of its approach, without touching in the center—a circumstance which always requires to

be guarded against in the combination of achromatic glasses. The preceding table shows the radii of curvature of the lenses of a triple object-glass, calculated from formula deduced by Dr. Robison of Edinburgh.

The following table contains the proportions of curvature said to be employed by the London opticians:

Focal length.	Convex lens of crown glass.				Radius of both the surfaces of the concave of flint glass.				Convex lens of crown glass.					
	Inches.	Inc.	Dec.	Inc.	Dec.	Inc.	Dec.	Inc.	Dec.	Inc.	Dec.	Inc.	Dec.	
6	3.	77	4.	49	3.	47	3.	77	4.	49	3.	77	4.	49
9	5.	65	6.	74	5.	21	5.	65	6.	74	5.	65	6.	74
12	7.	54	8.	99	6.	95	7.	54	8.	99	7.	54	8.	99
18	11.	30	13.	48	10.	42	11.	30	13.	48	11.	30	13.	48
24	15.	08	17.	98	13.	90	15.	08	17.	98	15.	08	17.	98
36	22.	61	26.	96	20.	84	22.	61	26.	96	22.	61	26.	96
42	26.	38	31.	45	24.	31	26.	38	31.	45	26.	38	31.	45
48	30.	16	35.	96	27.	80	30.	16	35.	96	30.	16	35.	96
54	33.	91	40.	45	31.	27	33.	91	40.	45	33.	91	40.	45
60	37.	68	44.	94	34.	74	37.	68	44.	94	37.	68	44.	94

From this table it appears that the two convex lenses have the same radii of their respective sides, and that the concave flint lens has its two surfaces equally concave, so that a triple object-glass formed according to these proportions would require only three pair of grinding tools. The following are the curves of the lenses of one of the best of Dollond's achromatic telescopes, the focal length of the compound object-glass being 46 inches. Reckoning from the surface next the object, the radii of the crown glass were 28 and 40 inches; the concave lens 20.9 inches, and the inner crown glass lens 28.4 and 28.4 inches. This telescope carried magnifying powers of from 100 to 200 times.

Although I have inserted the above tables, which might, in some measure, guide an ingenious artist, yet, on the whole, a private amateur has little chance in succeeding in such attempts. The diversity of glasses, and the uncertainty of an unpracticed workman's producing the precise curvature he intends, is so great, that the object-glass, for the most part, turns out different from his expectations. The great difficulty in the construction is to find the exact proportion of the dispersive powers of the crown and flint glass. The crown is pretty constant, but there are hardly two pots of flint glass which have the same dispersive power. Even if constant, it is difficult to measure it accurately; and an error in this greatly affects the instrument, because the focal distances of the lenses must be nearly as their dispersive powers. In the two preceding tables, the sine of incidence in the crown glass is supposed to be to the sine of refraction as 1.526 to 1; and in the flint glass, as 1.604 to one. Opticians who make great numbers of lenses, both of flint and crown glass, acquire, in time, a pretty good guess of the nature of the errors which may remain after they have finished an object-glass; and having many lenses intended to be of the same form, but unavoidably differing a little from it, they try several of the concaves with the two convexes, and finding one better than the rest, they make use of it to complete the set. In this way some of the best achromatic telescopes are frequently formed. I have sometimes found, when supplying a concave flint glass to a telescope where it happened to be wanting, that, of four or five concave lenses which appeared to be

the same as to curvature and other properties, only one was found to produce a distinct and colorless image. Should any one, however, wish to attempt the construction of an achromatic telescope, the best way for preventing disappointments in the result is to procure a variety of tables of the respective curvatures founded on different conditions, and which, of course, require the surfaces of the several lenses to be of different curves. Having lenses of different radii at his command, and having glass of different refractive or dispersive powers, when one combination does not exactly suit, he may try another, and ultimately may succeed in constructing a good achromatic telescope; for, in many cases, it has been found that chance, or a happy combination of lenses by trial, has led to the formation of an excellent object-glass.

#### ACHROMATIC TELESCOPES COMPOSED OF FLUID LENSES.

The best achromatic telescopes, when minutely examined, are found to be in some respects defective, on account of that slight degree of color which, by the aberration of the rays, they give to objects, unless the object-glass be of small diameter. When we examine with attention a good achromatic telescope, we find that it does not show white or luminous objects perfectly free from color, their edges being tinged on one side with a claret colored fringe, and on the other with a green fringe. This telescope, therefore, required further improvement, to get rid of these secondary colors, and Father Boscovich, to whom every branch of optics is much indebted, displayed much ingenuity in his attempts to attain this object. But it is to Dr. Blair, professor of astronomy in Edinburgh, that we are chiefly indebted for the first successful experiments by which this end was accomplished. By a judicious set of experiments, he proved that the quality of dispersing the rays in a greater degree than crown glass is not confined to a few mediums, but is possessed by a great variety of fluids, and by some of these in a most extraordinary degree. Having observed that when the extreme red and violet rays were perfectly united, the green were left out, he conceived the idea of making an achromatic concave lens which should refract the green less than the

united red and violet, and an achromatic convex lens which should do the same; and as the concave lens refracted the outstanding green to the axis, while the concave one refracted them from the axis, it followed that, by a combination of these two opposite effects, the green would be united with the red and violet.

By means of an ingenious prismatic apparatus, he examined the optical properties of a great variety of fluids. The solutions of metals and semi-metals proved in all cases more dispersive than crown glass. Some of the salts, such as sal ammoniac, greatly increased the dispersive power of water. The marine acid disperses very considerably, and this quality increases with its strength. The most dispersive fluids were accordingly found to be those in which this acid and the metals were combined. The chemical preparation called *causticum antimoniale*, or butter of antimony, in its most concentrated state, when it has just attracted sufficient humidity to render it fluid, possesses the quality of dispersing the rays in an astonishing degree. The great quantity of the semi-metal retained in solution, and the highly concentrated state of the marine acid, are considered as the cause of this striking effect. Corrosive sublimate of mercury, added to a solution of *sal ammoniacum* in water, possesses the next place to the butter of antimony among the dispersive fluids which Dr. Blair examined. The essential oils were found to hold the next rank to metallic solutions among fluids which possess the dispersive quality, particularly those obtained from bituminous minerals, as native petroleum, pitch, and amber. The dispersive power of the essential oil of saffron, and the essential oil of lemons, when genuine, were found to be not much inferior to any of these. But of all the fluids fitted for optical purposes, Dr. Blair found that the *muratic acid mixed with a metallic solution*, or, in other words, a fluid in which the marine acid and metallic particles hold a due proportion, most accurately suited his purpose. In a spectrum formed by this fluid, the green were among the most refrangible rays; and when its dispersion was corrected by that of glass, there was produced an inverted secondary spectrum, that is, one in which the green was above, when it would have been below with a common medium. He therefore placed a concave lens of muriatic acid with a metallic solution between the two lenses, as in fig. 60, where *AB* is the concave fluid lens, *CF* a plano-convex lens, with its plane side next the object, and *ED* a meniscus. With this object-glass the rays of different colors were bent from their recti-

Fig. 60.

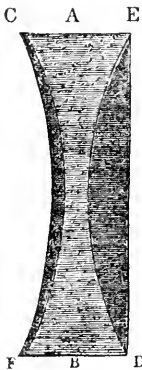

lineal course with the same equality and regularity as in reflection.

Telescopes constructed with such object-glasses were examined by the late Dr. Robison and Professor Playfair. The focal distance of the object-glass of one of these did not exceed 17 inches, and yet it bore an aperture of  $3\frac{1}{2}$  inches. They viewed some single and double stars and some common objects with this telescope, and found that in magnifying power, brightness, and distinctness, it was manifestly superior to one of Mr. Dollond's of 42 inches focal length. They had most dis-

tinct vision of a star, when using an erecting eyepiece, which made this telescope magnify more than 100 times, and they found the field of vision as uniformly distinct as with Dollond's 42 inch telescope, magnifying 46 times, and were led to admire the nice figuring and centering of the very deep eyeglasses which were necessary for this amplification. They saw double stars with a degree of perfection which astonished them. These telescopes, however, have never yet come into general use; and one reason, perhaps, is, that they are much more apt to be deranged than telescopes constructed of object-glasses which are solid. If any species of glass, or other solid transparent substance could be found with the same optical properties, instruments might perhaps be constructed of a larger size, and considerably superior to our best achromatic telescopes.\* It is said that Mr. Blair, the son of Dr. Blair, some years ago engaged in prosecuting his father's views, but I have not heard anything respecting the result of his investigations.

#### BARLOW'S REFRACTING TELESCOPE WITH A FLUID CONCAVE LENS.

Professor Barlow, not many years ago suggested a new fluid telescope, which is deserving of attention, and about the year 1829 constructed one of pretty large dimensions. The fluid he employs for this purpose is the *sulphuret of carbon*, which he found to be a substance which possessed every requisite he could desire. Its index is nearly the same as that of the best flint glass, with a dispersive power more than double. It is perfectly colorless, beautifully transparent, and, although very expansible, possesses the same, or very nearly the same, optical properties under all circumstances to which it is likely to be exposed in astronomical observations, except, perhaps, direct observations on the solar disc, which will probably be found inadmissible. Mr. Barlow first constructed an object-glass with this fluid of three inches aperture, with which he could see the small star in Polaris with a power of 46, and with the higher powers several stars which are considered to require a good telescope, for example, 70,  $\rho$  Ophiuchi, 29 Bootes, the quadruple star  $\epsilon$  Lyrae,  $\zeta$  Aquarii,  $\alpha$  Herculis, &c. He next constructed a 6 inch object-glass. With this instrument, the small star in Polaris is so distinct and brilliant, with a power of 143, that its transit might be taken with the utmost certainty. As the mode of constructing these telescopes is somewhat novel, it may be expedient to enter somewhat into detail.

In the usual construction of achromatic telescopes, the two or three lenses composing the object-glass are brought into immediate contact; and in the fluid telescope of Dr. Blair, the construction was the same, the fluid having been inclosed in the object-glass itself. But in Mr. Barlow's telescope, the fluid correcting lens is placed at a distance from the plate lens equal to half its focal length, and it might be carried still farther back, and yet possess dispersive power to render the object-glass achromatic. By this means, the fluid lens, which is the most difficult part of the construction, is reduced to one-half, or to less than one-half of the size of the plate lens; consequently, to construct a telescope of 10 or 12 inches aper-

\* For a more particular account of Dr. Blair's instruments and experiments, the reader is referred to his Dissertation on this subject in vol. ii. of the "Transactions of the Royal Society of Edinburgh," which occupies 76 pages, or to Nicholson's "Journal of Natural Philosophy," &c., quarto series, vol. i. April—September, 1797.

ture involves no greater difficulty in the manipulation than in making a telescope of the usual description of 5 or 6 inches aperture, except in the simple plate lens itself; and, hence, a telescope of

this kind of 10 or 12 feet length will be equivalent, in its focal power, to one of 16 or 20 feet. By this means the tube may be shortened several feet, and yet possess a focal power more considerable than

Fig. 61.

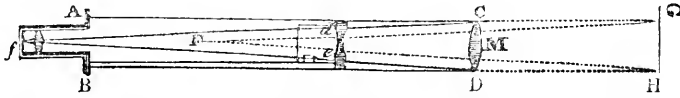

could be conveniently given to it on the usual principle of construction. This will be better understood from the above diagram (fig. 61).

In this figure  $ABCD$  represent the tube of the 6 inch telescope,  $CD$  the plate object-glass,  $F$  the first focus of rays,  $d$  the fluid concave lens, distant from the former 24 inches; the focal length  $MF$  being 48, and, consequently, as  $48 : 6 :: 24 : 3$  inches, the diameter of the fluid lens. The resulting compound focus is 62.5 inches. It is obvious, therefore, that the rays  $d f$ ,  $e f$ , arrive at the focus under the same convergency, and with the same light as if they proceeded from a lens of six inches diameter, placed at a distance beyond the object-glass  $CD$  (as  $GH$ ), determined by producing those rays until they meet the sides of the tube in  $GH$ , namely, at 62.5 inches beyond the fluid lens. Hence, it is obvious, the rays will converge as they would do from an object-glass,  $GH$ , of the usual kind with a focus of 10 feet 5 inches. We have thus, therefore, shortened the tube 38.5 inches, or have at least the advantage of a focus 38.5 inches longer than our tube; and the same principle may be carried much further, so as to reduce the usual length of refracting telescopes nearly one half, without increasing the aberration in the first glass beyond the least that can possibly belong to a telescope of the usual kind of the whole length. It should likewise be observed, that the adjustment for focus may be made either in the usual way or by a slight movement of the fluid lens, as in the Gregorian Reflectors by means of the small speculum.

Mr. Barlow afterward constructed another larger telescope on the same principle, the clear aperture of which is  $\frac{7}{8}$  inches. Its tube is 11 feet, which, together with the eyepiece, makes the whole length 12 feet, but its effective focus is, on the principle stated, 18 feet. It carries a power of 700 on the closest double stars in South's and Herschel's catalogue, and the stars are, with that power, round and defined, although the field is not then so bright as could be desired. The telescope is mounted on a revolving stand, which works with considerable accuracy as an azimuth and altitude instrument. To give steadiness to the stand, it has been made substantial and heavy, its weight by estimation being about 400 pounds, and that of the telescope 130 pounds, yet its motions are so smooth, and the power so arranged, that it may be managed by one person with the greatest ease, the star being followed by a slight touch, scarcely exceeding that of the keys of a piano-forte. The focal length of the plate lens is 78 inches, and of the fluid lens 59.8 inches; which, at the distance of 40 inches, produce a focal length of 104 inches, a total length of 12 feet, and an equivalent focus of 18 feet. The curves of the parallel meniscus checks for containing the fluid are 30 inches and 144 inches, the latter toward the eye. The curves for the plate lens are 56.4 and 144. There is an interior tube 5 inches diameter, and 3 feet

6 inches long, which carries the cell in which the fluid is inclosed, and an apparatus by which it may be moved backward and forward, so that the proper adjustment may be made for color in the first instance, and afterward the focus is obtained by the usual rack-work motion. The following is the mode by which the fluid was inclosed. After the best position has been determined practically for the checks forming the fluid lens, these, with the ring between them, ground and polished accurately to the same curves, are applied together, and taken into an artificial high temperature, exceeding the greatest at which the telescope is ever expected to be used. After remaining here with the fluid some time, the space between the glasses is completely filled, immediately closed, cooled down by evaporation, and removed into a lower temperature. By this means a sudden condensation takes place, an external pressure is brought on the checks, and a bubble formed inside, which is, of course, filled with the vapor of the fluid; the excess of the atmospheric pressure beyond that of the vapor being afterward always acting externally to prevent contact. The extreme edges are then sealed with the serum of human blood, or by strong fish glue, and some thin pliable metal surface. By this process, Mr. Barlow says, "I have every reason to believe the lens becomes as durable as any lens of solid glass. At all events, I have the satisfaction of stating, that my first 3 inch telescope has now been completed more than fifteen months, and that no change whatever has taken place in its performance, nor the least perceptible alteration either in the quantity or the quality of the fluid."

The following are some of the observations which have been made with this telescope, and the tests to which it has been subjected. The very small star which accompanies the pole star is generally one of the first tests applied to telescopes. This small point of light appeared brilliant and distinct; it was best seen with a power of 120, but was visible with a power of 700. The small star in Aldebaran was very distinct with a power of 120. The small star  $\alpha$  Lyrae was distinctly visible with the same power. The small star called by Sir J. Herschel *Debilissima*, between 4 and 5 Lyrae, whose existence, he says, could not be suspected in either the 5 or 7 feet equatorial, and invisible also with the 7 and 10 feet reflectors of 6 and 9 inches aperture, but seen double with the 20 feet reflector, is seen very satisfactorily double with this telescope,  $\alpha$  Persi, marked as double in South and Herschel's catalogue, at the distance of 28', with another small star at the distance of 3' 67", is seen distinctly sixfold, four of the small stars being within a considerably less distance than the remote one of  $\alpha$  marked in the catalogue. And, rejecting the remote star, the principal and the four other stars form a miniature representation of Jupiter and his satellites, three of them being nearly in a line on one side, and the other on the opposite. *Castor* is distinctly double with

120, and well opened, and stars perfectly round with 360 and 700.  $\gamma$  Leonis and  $\alpha$  Piscium are seen with the same powers equally round and distinct. In  $\epsilon$  Bootis, the small star is well separated from the larger, and its blue color well marked with a power of 360.  $\alpha$  Corona Borealis is seen double with a power of 360 and 700.  $\delta$  Orionis,  $\zeta$  Orionis and others of the same class, are also well-defined with the same powers. In regard to the planets which happened to be visible, Venus appeared beautifully white and well-defined with a power of 120, but showed some color with 360. Saturn with the 120 power is a very brilliant object, the double ring and belts being well and satisfactorily defined, and with the 360 power it is still very fine. The moon also is remarkably beautiful, the edges and the shadows being well marked, while the quantity of light is such as to bring to view every minute distinction of figure and shade.

The principal objections that may be made to this construction of a telescope are such as these: Can the fluid be permanently secured? Will it preserve its transparency and other optical properties? Will it not act upon the surface of the glass and partially destroy it? &c. To such inquiries Mr. Barlow replies, that experience is the only test we have; our spirit levels, spirit thermometers, &c., show that some fluids, at least, may be preserved for many years without experiencing any change, and without producing any in the appearance of the glass tubes containing them. But should any of these happen, except the last, nothing can be more simple than to supply the means of replacing the fluid at any time, and by any person, without disturbing the adjustment of the telescope. He expresses his hope that, should these experiments be prosecuted, an achromatic telescope shall ultimately be produced which shall exceed in aperture and power any instruments of the kind hitherto attempted. If the prejudice against the use of fluids could be removed, he feels convinced that well-directed practice would soon lead to the construction of the most perfect instruments, on this principle, at a comparatively small expense. "I am convinced," he says, "judging from what has been paid for large object-glasses, that my telescope, telescope stand, and the building for observation, with every other requisite convenience, have been constructed for a less sum than would be demanded for the object-glass only, if one could be produced of the same diameter of plate and flint glass; and this is a consideration which should have some weight, and encourage a perseverance in the principle of construction."\*

#### ROGERS'S ACHROMATIC TELESCOPE ON A NEW PLAN.

The object of this construction is to render a small disc of flint glass available to perform the office of compensation to a much larger one of crown glass, and thus to render possible the construction of telescopes of much larger aperture than are now common, without hindrance from the difficulty at present experienced in procuring large discs of flint glass. It is well known to those who are acquainted with telescopes, that in

the construction of an ordinary achromatic object-glass, in which a single crown lens is compensated by a single one of flint, the two lenses admit of being separated only by an interval too small to afford any material advantage, in diminishing the diameter of the flint lens, by placing it in a narrow part of the cone of rays, the actual amount of their difference in point of dispersive power being such as to render the correction of the chromatic aberration impossible when their mutual distance exceeds a certain limit. This inconvenience Mr. Rogers proposes to obviate by employing, as a correcting lens, not a single lens of flint, but a compound one consisting of a convex crown and concave flint, whose foci are such as to cause their combination to act as a plain glass on the mean refrangible rays. Then it is evident that by means of the greater dispersive power of flint than of crown glass, this will act as a concave on the violet, and as a convex on the red rays, and that the more powerfully, according as the lenses separately have greater powers or curvature. If then, such a compound lens be interposed between the object-glass of a telescope—supposed to be a single lens of plate or crown glass—and its focus, it will cause no alteration in the focus for mean rays, while it will lengthen the focus for violet, and shorten it for red rays. Now this is precisely what is wanted to produce an achromatic union of all the rays in the focus; and as nothing in this construction limits the powers of the individual correcting lenses, they may therefore be applied anywhere that convenience may dictate; and, thus, theoretically speaking, a disc of flint glass, however small, may be made to correct the color of one of crown, however large.

This construction likewise possesses other and very remarkable advantages: for, first, when the correcting lens is approximately constructed on a calculation founded on its intended aperture, and on the refractive and dispersive indices of its materials, the final and complete dispersion of color may be effected, not by altering the lenses by grinding them anew, but by shifting the combination nearer to, or farther from the object-glass, as occasion may require, along the tube of a telescope, by a screw motion, until the condition of achromaticity is satisfied in the best manner possible; and, secondly, the spherical aberration may in like manner be finally corrected, by slightly separating the lenses of the correcting glass, whose surfaces should for this purpose be figured to curvatures previously determined by calculation to admit of this mode of correction—a condition which Mr. Rogers finds to be always possible. The following is the rule which he lays down for the determination of the foci of the lenses of the correcting glass: "The focal length of either lens is to that of the object-glass in a ratio compounded of the ratio of the square of the aperture of the correcting lens to that of the object-glass, and of the ratio of the difference of the dispersive indices of the crown and flint glass to the dispersive index of crown." For example, to correct the color of a lens of crown or plate glass of 9 inches aperture and 14 feet focal length (the dimensions of the telescope of Fraunhofer, at Dorpat) by a disc of flint glass 3 inches in diameter, the focus of either lens of the correcting lens will require to be about 9 inches. To correct it by a 4 inch disc will require a focus of about 16 inches each.

Mr. Rogers remarks, that it is not indispensable to make the correcting glass act as a plano lens. It is sufficient if it be so adjusted as to have a shorter focus for red rays than for violet. If

\* A more detailed account of the processes connected with the construction of this telescope will be found in a paper presented to the Royal Society in 1827, and published in the Philosophical Transactions of that Society for 1828, and likewise another paper, published in the Transactions for 1829. From these documents, chiefly, the preceding account has been abridged. See also the "Edinburgh New Philosophical Journal" for January—April, 1828, and Brewster's "Edinburgh Journal of Science" for October, 1829.



preserving this condition, it be made to act as a concave lens, the advantage procured by Mr. Barlow's construction of reducing the length of the telescope with the same focal power is secured; and he considers, moreover, that by a proper adaptation of the distances, foci, &c., of the lenses, we might hope to combine with all these advantages that of the destruction of the secondary spectrum, and thus obtain a perfect telescope.

The above is an abstract of a paper read to the "Astronomical Society of London" in April, 1828, by A. Rogers, Esq.

The reader will easily perceive that the principle on which Mr. Rogers proposes to construct his telescope is very nearly similar to that of Professor Barlow, described above, with this difference, that the correcting lens of the professor's telescope is composed of a transparent *fluid*, while that of Mr. Rogers is a *solid* lens consisting of a convex crown and concave flint. The general object intended to be accomplished by both is the same, namely, to make a correcting lens of a comparatively small diameter serve the purpose of a large disc of flint glass, which has hitherto been very expensive, and very difficult to be procured; and likewise to reduce the length of the telescope, while the advantage of a long focal power is secured. A telescope on this principle was constructed seven or eight years ago by Mr. Wilson, lecturer on Philosophy and Chemistry, Glasgow, before he was aware that Mr. Rogers had proposed a similar plan. I have had an opportunity of particularly inspecting Mr. Wilson's telescope, and trying its effects on terrestrial objects with high powers, and was, on the whole,

highly pleased with its performance. It appeared to be almost perfectly achromatic, and produced a distinct and *well-defined* image of minute distant objects, such as small letters on sign posts, at two, three, and four miles distant; but I had no opportunity of trying its effects on double stars or any other celestial objects. The instrument is above 6 feet long; the object-lens is a plano-convex of crown glass, 4 feet focal distance and 4 inches diameter, the plain side next the object.

At 26 inches distant from the object-lens is the compound lens of 2 inches in diameter; and the two lenses of which it is composed are both ground to a radius of  $3\frac{1}{4}$  inches. That made of crown glass is *plano-convex*, the other, made of flint glass, is *plano-concave*, and are placed close together, the convex side being next the object, and the concave side next the eye. The greater refractive power of the flint glass renders the compound one slightly concave in its effect (although the radius of curvature is similar in both), and lengthens the focus to 6 feet from the object-glass; and this is consequently the length of the instrument. The compound corrector so placed intercepts all those rays which go to form the image in the field of view, producing there an achromatic image. The concave power of the corrector renders the image larger than if directly produced by a convex lens of the same focus. The concavity of the corrector is valuable also in this respect, that a very slight alteration in its distance from the object-glass changes the focal distance much more than if it were plain, and enables us to adjust the instrument to perfect achromatism with great precision.

## CHAPTER V.

### ON REFLECTING TELESCOPES.

#### SECTION I.

##### HISTORY OF THE INVENTION, AND A GENERAL DESCRIPTION OF THE CONSTRUCTION OF THESE INSTRUMENTS.

REFLECTING telescopes are those which represent the images of distant objects by reflection, chiefly from concave mirrors.

Before the achromatic telescope was invented there were two glaring imperfections in refracting telescopes, which the astronomers of the seventeenth century were anxious to correct. The first was its very great length when a high power was to be applied, which rendered it very unwieldy and difficult to use. The second imperfection was the incorrectness of the image as formed by a single lens. Mathematicians had demonstrated that a pencil of rays could not be collected in a single point by a spherical lens, and also that the image transmitted by such a lens would be in some degree incurvated. After several attempts had been made to correct this imperfection by grinding lenses to the figure of one of the conic sections, Sir I. Newton happened to commence an examination of the colors formed by a prism; and having, by the means of this simple instrument, discovered the different refrangibility of the rays of light—to which we have several times adverted in the preceding descrip-

tions—he then perceived that the errors of telescopes, arising from that cause alone, were some hundred times greater than such as were occasioned by the spherical figure of lenses, which induced this illustrious philosopher to turn his attention to the improvement of telescopes by reflection.

It is generally supposed that Mr. James Gregory,—a son of the Rev. John Gregory, minister of Drumoak, in the county of Aberdeen—was the first who suggested the construction of a reflecting telescope. He was a young man of uncommon genius, and an eminent mathematician; and in the year 1663, at the age of only 24, he published in London his treatise entitled "Optica Promota," in which he explained the theory of that species of reflecting telescope which still bears his name, and which he stated as being his own invention. But as Gregory, according to his own account, was endowed with no mechanical dexterity, and could find no workman capable of realizing his invention, after some fruitless attempts to form proper specula, he was obliged to give up the pursuit, so that this telescope remained for a considerable time neglected. It was several years after Gregory suggested the construction of reflecting telescopes before Newton directed his attention fully to the subject. In a letter addressed to the secretary of the Royal Society, dated in February, 1672, he says, "Finding reflections to be regular, so that the angle of reflection of all sorts of rays was equal to the

angle of incidence, I understood, that by their mediation, optic instruments might be brought to any degree of perfection imaginable, providing a reflecting substance could be found which would polish as finely as glass, and reflect as much light as glass transmits, and the art of

brightness and magnifying power, all the instruments of this description, which had previously been attempted.

I shall now proceed to give a brief sketch of the nature of a reflecting telescope, and the different forms in which they have been proposed to be constructed.

Fig. 62.

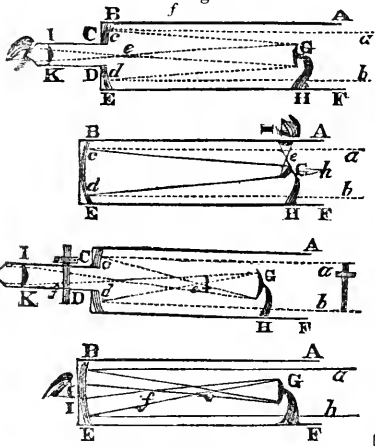
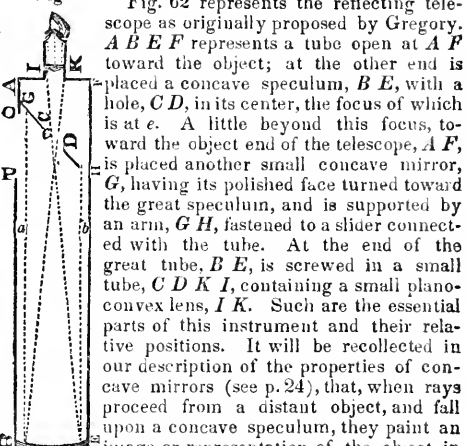

Fig. 63.

Fig. 64.

Fig. 65.

Fig. 66.



communicating to it a parabolic figure he also obtained. Amid these thoughts I was forced from Cambridge by the intervening plague, and it was more than two years before I proceeded further."

It was toward the end of 1668, or in the beginning of the following year, when Newton, being obliged to have recourse to reflectors, and not relying on any artificer for making the specula, set about the work himself, and early in the year 1672, completed two small reflecting telescopes. In these he ground the great speculum into a spherical concave, although he approved of the parabolic form, but found himself unable to accomplish it. These telescopes were of a construction somewhat different from what Gregory had suggested, and although only 6 inches long, were considered as equal to a six feet common refracting telescope. It is not a little singular, however, that we hear no more about the construction of reflectors until more than half a century afterward. It was not until the year 1723 that any reflectors were known to have been made, adapted to celestial observations. In that year Mr. Hadley, the inventor of the reflecting quadrant which goes by his name, published in No. 376 of the Philosophical Transactions, an account of a large reflector on Newton's plan, which he had just then constructed, the performance of which left no room to doubt that this invention would remain any longer in obscurity. The large speculum of this instrument was  $62\frac{5}{8}$  inches focal distance and 5 inches diameter, was furnished with magnifying powers of from 190 to 230 times, and equaled in performance the famous aerial telescope of Huygens of 123 feet in length.\* Since this period the reflecting telescope has been in general use among astronomers in most countries of Europe, and has received numerous improvements, under the direction of Short, Mudge, Edwards, and Herschel, the last of whom constructed reflectors of 7, 10, 20, and even 40 feet in focal length, which far surpassed, in

its focus before the speculum. Now suppose two parallel rays,  $a, b$ , falling on the speculum  $BE$ , in  $cd$ ; they are reflected to its focus  $e$ , where an inverted image of the object is formed at a little more than the focal distance of the small speculum from its surface, and serves, as it were, for an object on which the small mirror may act. By the action of this mirror this first image is reflected to a point about  $f$ , where a second image is formed very large and erect. This image is magnified in the proportion of  $fG$  to  $eG$ , the rays from which are transmitted to the eyeglass  $IK$ , through which the eye perceives the object clear and distinct, after the proper adjustments have been made.

Suppose the focal distance of the great mirror was 9 inches, and the focal distance of the small mirror  $1\frac{1}{2}$  inch—were we to remove the eyepiece of this telescope, and look through the hole of the great mirror, we should see the image of the object depicted upon the face of the small speculum, and magnified in the proportion of 9 to  $1\frac{1}{2}$ , or 6 times, on the same principle as a common convex object-glass 9 inches focal length, with an eyeglass whose focus is  $1\frac{1}{2}$  inch, magnifies 6 times. This may be regarded as the first part of the magnifying power. If, now, we suppose the small speculum placed a little more than  $1\frac{1}{2}$  inch from the image formed by the great speculum, a second image is formed about  $f$ , as much exceeding the first in its dimensions as it exceeds it in distance from the small speculum, on the principle on which the object-glass of a compound microscope forms a large image near the eyeglass. Suppose this distance to be 9 times greater, then the whole magnifying power will be compounded of 6 multiplied by 9, or 54 times. As a telescope it magnifies 6 times, and in the microscope part 9 times. Such is the general idea of the Gregorian telescope, the minute particulars and structure of which can only be clearly perceived by a direct inspection of the instrument.

*The Newtonian Reflector.*—This instrument is somewhat different both in its form and in its mode of operation from that of Gregory. It is represented in fig. 63, where  $BAEF$  is the tube,

\* A particular description of this telescope, with the machinery for moving it, illustrated with an engraving, may be seen in Reid and Gray's "Abridgement of the Philosophical Transactions," vol. vi, Part 1 for 1723, p. 147—152.

and *BE* the object concave mirror, which reflects the parallel rays *ab* to a plane speculum *G*, placed  $45^\circ$ , or half a right angle to the axis of the concave speculum. This small plane reflector must be of an oval form; the length of the oval should be to the breadth as 7 to 5, on account of the obliquity of its position. It is supported on an arm fixed to the side of the tube; an eyeglass is placed in a small tube, movable in the larger tube, so as to be perpendicular to the axis of the large reflector, the perpendicular line passing through the center of the small mirror. The small mirror is situated between the large mirror and its focus, that its distance from this focal point may be equal to the distance from the center of the mirror to the center of the eyeglass. When the rays *ab* from a distant object fall upon the large speculum at *cd*, they are reflected toward a focus at *h*; but, being intercepted by the plane mirror *G*, they are reflected perpendicularly to the eyeglass at *I*, in the side of the tube, and the image formed near that position at *e* is viewed through a small plano-convex lens. The magnifying power of this telescope is in the proportion of the focal distance of the speculum to that of the eyeglass. Thus, if the focal distance of the speculum be 36 inches, and that of the eyeglass one-third of an inch, the magnifying power will be 108 times. It was this form of the reflecting telescope that Newton invented, which Sir W. Herschel adopted, and with which he made most of his observations and discoveries.

**The Cassegrainian Reflector.**—This mode of the reflecting telescope, suggested by M. Cassegrain, a Frenchman, is represented in fig. 64. It is constructed in the same way as the Gregorian, with the exception of a small convex speculum, *G*, being substituted in the room of the small concave in Gregory's construction. As the focus of a convex mirror is negative, it is placed at a distance from the large speculum equal to the difference of their foci; that is, if the focal length of the large speculum be 18 inches, and that of the small convex 2 inches, they are placed at 16 inches distant from each other, on a principle similar to that of the Galilean telescope, in which the concave eyeglass is placed within the focus of the object-glass by a space equal to the focal length of the eyeglass. In this telescope, likewise, instead of two there is only *one image* formed, namely, that in the focus of the eyeglass; and, on this account, some are of opinion that the distinctness is considerably greater than in the Gregorian. Mr. Ramsden was of opinion that this construction is preferable to either of the former reflectors, because the aberrations of the two metals have a tendency to correct each other, whereas in the Gregorian, both the metals being concave, any error in the specula will be doubled. It is his opinion that the aberrations in the Cassegrainian construction to that of the Gregorian is as 3 to 5. The length of this telescope is shorter than that of a Gregorian of equal focal length by twice the focal length of the small mirror, and it shows everything in an *inverted* position, and, consequently, is not adapted for viewing terrestrial objects.

**Dr. Hook's Reflector.**—Before the reflecting telescope was much known, Dr. Hook contrived one, the form of which is represented fig. 65, which differs in little or nothing from the Gregorian, except that the eyeglass, *I*, is placed in the hole of the great speculum, *BE*.

**Martin's Reflector.**—Mr. Benjamin Martin a distinguished writer on optical and philosophical

science, about a century ago, described a new form of the reflecting telescope, approximating to the Newtonian structure, which he contrived for his own use. It is represented in fig. 66. *ABEF* is the tube, in which there is an opening or aperture, *OP*, in the upper part. Against this hole, within the tube, is placed a large plane speculum, *GH*, at half a right angle with the axis or sides of the tubes, with a hole, *CD*, perforated through its middle. The parallel rays *a, b*, falling on the inclined plane *GH*, are reflected perpendicularly and parallel on the great speculum *BE* in the bottom of the tube. From thence they are reflected, converging to a focus, *e*, through the hole of the plane mirror *CD*, which, being also the focus of the eyeglass *IK*, the eye will perceive the object magnified and distinct.

In the figures referred to in the above descriptions, only one eyeglass is represented, to avoid complexity; but in most reflecting telescopes, the eyepiece consists of a combination of two plano-convex glasses, as in fig. 67, which produces a more correct and a larger field of view than a single lens. This combination is generally known by the name of the *Huygenian Eyepiece*, which shall be described in the section on the *eyepieces* of telescopes.

The following rule has been given for finding the magnifying power of the Gregorian telescope: Multiply the focal distance of the great mirror by the distance of the small mirror from the image next the eye, and multiply the focal distance of the small mirror by the focal distance of the eyeglass; then divide the product of the former multiplication by the product of the latter, and the quotient will express the magnifying power. The following are the dimensions of one of the reflecting telescopes constructed by Mr. Short, who was long distinguished as the most eminent maker of such instruments on a large scale, and whose large reflectors are still to be found in various observatories throughout Europe:

The focal distance of the great mirror, 9.6 inches; or *Pm*, fig. 67, its breadth, *FD*, 2.3; the focal distance of the small mirror, *Ln*, 1.5, or  $1\frac{1}{2}$  inch; its breadth, *gh*, 0.6 or 6-10ths of an inch; the breadth in the hole in the great mirror, *UV*, 0.5, or half an inch; the distance between the small mirror and the next eyeglass, *LR*, 14.2;

Fig. 67.

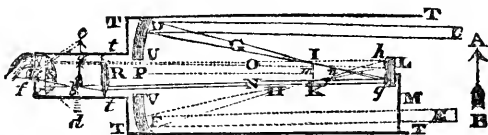

the distance between the two eyeglasses, *SR*, 2.4; the focal distance of the eyeglass next the metal, 3.8; and the focal distance of the eyeglass next the eye, *Sa*, 1.1, 11-10ths of an inch. The magnifying power of this telescope was about 60 times. Taking this telescope as a standard, the following table of the dimensions and magnifying powers of Gregorian reflecting telescopes, as constructed by Mr. Short, has been computed:

Mr. Short—who was born in Edinburgh in 1710, and died near London, 1768—was considered as the most accurate constructor of reflecting telescopes during the period which intervened from 1732 to 1768. In 1743 he constructed a reflector for Lord Thomas Spencer of 12 feet focal length, for which he received 600 guineas. He made several other telescopes of the same focal distance, with greater improvements and higher

Focal distance of the great mirror.		Breadth of the great mirror.		Focus of the small speculum.		Breadth of the hole in the great speculum.		Distance between the small speculum and the first eye-glass.		Focal distance of the glass next the metals.		Focal distance of the glass next the eye.		Distance between the plane sides of the two glasses.		Magnifying power.		Distance between the second glass and the small eye-hole.	
P	m	D	F	L	n	U	V	L	R	R	S	R	S	In.	Dec.	In.	Dec.	In.	Dec.
In.	Dec.	In.	Dec.	In.	Dec.	In.	Dec.	In.	Dec.	In.	Dec.	In.	Dec.	In.	Dec.	In.	Dec.	In.	Dec.
5.	65	1.	54	1.	10	0.	31	8.	54	2.	44	0.	81	1.	68	39		0.	41
9.	00	2.	30	1.	50	0.	59	14.	61	3.	13	1.	04	2.	09	60		0.	52
15.	50	3.	30	2.	14	0.	20	23.	81	3.	94	1.	31	2.	63	86		0.	66
26.	00	6.	26	3.	43	0.	65	41.	16	5.	12	1.	71	3.	41	165		0.	85
60.	00	9.	21	5.	00	0.	85	68.	17	6.	43	2.	14	4.	28	243		1.	87

magnifiers; and, in 1752, finished one for the King of Spain, for which, with its whole apparatus, he received £1200. This was considered the noblest instrument of its kind that had then been constructed, and perhaps it was never surpassed until Herschel constructed his twenty and forty feet reflectors. High as the prices of large telescopes now are, Mr. Short charged for his instruments at a much higher rate than opticians now do, al-

though the price of labor, and every other article required in the construction of a telescope is now much dearer. But he had then scarcely any competitor, and he spared neither trouble nor expense to make his telescopes perfect, and put such a price upon them as properly repaid him. The following table contains a statement of the apertures, powers, and prices of Gregorian telescopes, as constructed by Mr. James Short:\*

Number.	Focal length in inches.	Diameter of aperture in inches.	Magnifying powers.	Prices in guineas.
1	3	1.1	1 Power of	18 times, 3
2	4½	1.3	1 "	25 " 4
3	7	1.9	1 "	40 " 6
4	9½	2.5	2 Powers of	40 and 60 " 8
5	12	3.0	2 "	55 and 85 " 10
6	12	3.0	4 "	35, 55, 85, and 110 " 14
7	18	3.8	4 "	55, 95, 130, and 200 " 20
8	24	4.5	4 "	90, 150, 230, and 300 " 35
9	36	6.3	4 "	100, 200, 300, and 400 " 75
10	48	7.6	4 "	120, 260, 380, and 500 " 100
11	72	12.2	4 "	200, 400, 600, and 800 " 300
12	144	18.0	4 "	300, 600, 900, and 1200 " 800

From this table it appears that Mr. Short charged 75 guineas for a 3 feet reflector, whereas such an instrument is now marked in the London opticians' catalogues at £23 when mounted on a common brass stand, and £39 18s. when accompanied with rack-work motions and other apparatus. It is now generally understood that in the above table Short always greatly *overrated* the higher powers of his telescopes. By experiment, they were generally found to magnify *much less* than here expressed.

*General Remarks on Gregorian Reflectors.*—1. In regard to the hole, *U V*, of the great speculum, its diameter should be equal, or nearly so, to that of the small speculum, *L*, fig. 67; for if it be less, no more parallel rays will be reflected than if it were equal to *g h*, and it may do harm in contracting the visible area within too narrow limits; nor must it be larger than the mirror *L*, because some parallel rays will then be lost, and those of most consequence, as being nearest the center. 2. The small hole at *c*, to which the eye is applied, must be nicely adjusted to the size of the cone of rays proceeding from the nearest lens, *S*. If it be larger, it will permit the foreign light of the sky or other objects to enter the eye, so as to prevent distinct vision; for the eye should receive no light but what comes from the surface

of the small mirror, *L*. If the hole be smaller than the cylinder of rays at *c*, then some of the necessary light will be excluded, and the object rendered more obscure. The diameter of this hole may be found by dividing the aperture of the telescope in inches by its magnifying power. Thus, if we divide the diameter of one of Short's telescopes, the diameter of whose large speculum is 2.30, by 60, the magnifying power, the quotient will be .0383, which is nearly the 1-25th of an inch. Sometimes this hole is made so small as the 1-50th of an inch. When this hole is, by any derangement, shifted from its proper position, it sometimes requires great nicety to adjust it, and, before it is accurately adjusted, the telescope is unfit for accurate observation. 3. It is usual to fix a plate with a hole in it at *a b*, the focus of the eye-glass *S*, of such a diameter as will circumscribe the image, so as to exhibit only that part of it which appears distinct, and to exclude the superfluous rays. 4. There is an adjusting screw on the outside of the great tube, connected with the small speculum, by which that speculum may be pushed backward or forward to adjust the instrument to distinct vision. The hand is applied for this purpose at *T*.

*Newtonian Telescopes.*—These telescopes are now more frequently used for celestial observations than during the last century, when Gregorian reflectors were generally preferred. Sir W. Herschel was chiefly instrumental in introducing this form of the reflecting telescope to the more particular attention of astronomers, by the splendor and extent of the discoveries which it enabled him to make. In this telescope there is

\* Mr. Short, who has erected and who superintends an observatory on the Calton Hill, Edinburgh, is the descendant of a brother of Mr. Short. She is in possession of a large Gregorian reflector, about 12 feet long, made by Mr. Short, and mounted on an equatorial axis. It was originally placed in a small observatory erected on the Calton Hill about the year 1776, but for many years past it has been little used.

no hole required in the middle of the great speculum, as in the Gregorian construction, which circumstance secures the use of all the rays which flow from the central parts of the mirror.

The following table contains a statement of the apertures and magnifying powers of Newtonian telescopes, and the focal distances of their eyeglasses. The first column contains the focal length of the great speculum in feet; the second, its linear aperture in inches; the third, the focal distance of the single glass in decimals, or in 1000ths of an inch, and the fourth column contains the magnifying power. This portion of the

table was constructed by using the dimensions of Mr. Hadley's Newtonian telescope, formerly referred to, as a standard, the focal distance of the great mirror being  $62\frac{1}{2}$  inches, its medium aperture 5 inches, and power 208. The fifth, sixth, and seventh columns contain the apertures of the concave speculum, the focal lengths of the eyeglasses, and the magnifying powers, as calculated by Sir D. Brewster, from a telescope of Mr. Hawksbee, taken as a standard, whose focal length was 3 feet 3 inches, its aperture about 4 inches, and magnifying power 226 times.

One great advantage of reflecting telescopes

Focal distance of concave metal.	Aperture of concave metal.	Focal distance of single eyeglass.	Magnifying power.	Sir D. Brewster's Numbers.		Magnifying power.
				Aperture of the concave speculum.	Focal length of eyeglass.	
0 $\frac{1}{2}$	0. 86	0. 167	36	1. 34	0. 107	56
1	1. 44	0. 199	60	2. 23	0. 129	93
2	2. 45	0. 236	102	3. 79	0. 152	158
3	3. 31	0. 261	138	5. 14	0. 168	214
4	4. 10	0. 281	171	6. 36	0. 181	265
5	4. 85	0. 297	202	7. 51	0. 192	313
6	5. 57	0. 311	232	8. 64	0. 200 = $\frac{1}{5}$	360
7	6. 24	0. 323	260	9. 67	0. 209	403
8	6. 89	0. 334	287	10. 44	0. 218	445
9	7. 54	0. 344	314	11. 69	0. 222	487
10	8. 16	0. 353	340	12. 65	0. 228	527
11	8. 76	0. 362	365	13. 58	0. 233	566
12	9. 36	0. 367	390	14. 50	0. 238	604
13	9. 94	0. 377	414	15. 41	0. 243	642
14	10. 49	0. 384	437	16. 25	0. 248	677
15	11. 04	0. 391	460	17. 11	0. 252	713
16	11. 59	0. 397	483	17. 98	0. 256	749
17	12. 14	0. 403	506	18. 82	0. 260	784
18	12. 67	0. 409	528	19. 63	0. 264	818
19	13. 20	0. 414	550	20. 45	0. 268	852
20	13. 71	0. 420	571	21. 24	0. 271	885

above common refractors is, that they will admit of eyeglasses of a much shorter focal distance, and, consequently, will magnify so much the more, for the rays are not colored by reflection from a concave mirror, if it be ground to a true figure, as they are by passing through a convex glass, though figured and polished with the utmost exactness. It will be perceived from the above table that the focal length of the eyeglasses is very small, the lowest there stated being only about 1-10th of an inch, and the highest little more than  $\frac{1}{4}$ th of an inch focal distance. Sir W. Herschel obtained the high powers which he sometimes put upon his telescopes by using small double convex lenses for eyeglasses, some of which did not exceed the *one fiftieth of an inch* in focal length. When the focal length of the concave speculum and that of the eyeglass are given, the magnifying power is found by dividing the former by the latter, after having reduced the focal length of the concave speculum to inches. Thus the 6 feet speculum, multiplied by 12, produces 72 inches, which, divided by Brewster's number for the focus of the eyeglass = 200, or 1-5th of an inch, produces a quotient of 360 as the magnifying power. It has been calculated that, if the metals of a Newtonian telescope be worked as exquisitely as those in Sir W. Herschel's 7 feet reflector, the highest power that such a telescope should bear with perfect distinctness will be found by multiplying the diameter of the great speculum in inches by 74, and the focal distance of the single eyeglass may be found by dividing the focal distance of the great mirror

by the magnifying power. Thus 6.25—the aperture in inches of Herschel's 7 feet Newtonian—multiplied by 74, is 462 $\frac{1}{2}$ , the magnifying power; and 7 multiplied by 12, and divided by 462, is 50.182 of an inch, the focal distance of the single eyeglass required. But it is seldom that more than one-half of this power can be applied with effect to any of the planetary bodies. For general purposes, the power produced by multiplying the diameter of the speculum by 30 or 40 will be found most satisfactory.

The following are the general prices of reflecting telescopes as made by the London opticians:

	£	s.
A four feet, seven inch aperture, Gregorian reflector, with the vertical motions upon a new invented principle, as well as apparatus to render the tube more steady in observation, according to the additional apparatus of small speculums, eyepieces, micrometers, &c. <span style="float: right;">from 80 to 120</span>	0	0
Three feet long, mounted on a plain brass stand . . . . .	23	2
Ditto, with rack-work motions, improved mounting, and metals . . . . .	39	18
Two feet long, without rack-work, and with 4 magnifying powers, improved . . . . .	15	15
Ditto, with rack-work motion . . . . .	22	1
Eighteen inch, on a plain stand . . . . .	9	9
Twelve inch, ditto . . . . .	6	6

The above are the prices stated in Messrs. W. and S. Jones's catalogue.

The following list of prices of the various kinds of reflecting telescopes is from Messrs. Tauley's (of Islington) catalogue:

	£.	s.
1 foot <i>Gregorian</i> reflector, on pillar and claw stand, metal $2\frac{1}{2}$ inches diameter, packed in a mahogany box	6	6
$1\frac{1}{2}$ foot ditto, on pillar and claw stand, metal 3 inches diameter, packed in a mahogany box	11	11
3 feet ditto, metal 4 inches diameter	16	16
Ditto, ditto, with rack-work motions	25	4
5 feet ditto, metal 5 inches diameter, with rack work motions	42	0
Ditto, metal 6 inches diameter, on a tripod stand, with center of gravity motion	68	5
4 feet ditto, metal 7 inches diameter, as above	105	0
6 feet ditto, metal 9 inches diameter, on an improved iron stand	210	0
7 feet <i>Newtonian</i> reflectors, 6 inches aperture, mounted on a new and improved stand	105	0
Ditto, ditto, metal 7 inches diameter	126	0
9 feet ditto, metal 9 inches diameter	210	0
10 feet ditto, metal 10 inches diameter	315	0
12 feet ditto, metal 12 inches diameter	525	0

*Comparative Brightness of Achromatic and Reflecting Telescopes.*—The late astronomer royal, Dr. Maskelyne, from a comparison of a variety of telescopes, was led to the following conclusion: "that the aperture of a common reflecting telescope, in order to show objects as bright as the achromatic, must be to that of an achromatic telescope as 8 to 5;" in other words, an achromatic whose object-glass is 5 inches in diameter, will show objects with as great a degree of brightness as a reflector whose large speculum is 8 inches in diameter. This result, if correct, must be owing to the small number of rays reflected from a speculum compared with the number transmitted through an achromatic object-glass.

## SECTION II.

### THE HERSCHELIAN TELESCOPE.

Soon after Sir William Herschel commenced his astronomical career, he introduced a new era in the history of reflecting telescopes. After he had cast and polished an immense variety of specula for telescopes of different sizes, he at length, in the year 1782, finished a 20 feet reflector with a large aperture. Being sensible of the vast quantity of light which is lost by a second reflection from the small speculum, he determined to throw it aside altogether, and mounted this 20 feet reflector on a stand that admitted of being used without a small speculum in making *front observations*; that is, in sitting with his back to the object, and looking directly toward the surface of the speculum. Many of his discoveries and measurements of double stars were made with this instrument, until at length, in the year 1785, he put the finishing hand to that gigantic speculum, which soon became the object of universal astonishment, and which was intended for his *forty feet* reflecting telescope. He had succeeded so well in constructing reflecting telescopes of comparatively small aperture, that they would bear higher

magnifying powers than had ever previously been applied; but he found that a deficiency of light could only be remedied by an increased diameter of the large speculum, which therefore was his main object when he undertook to accomplish a work which to a man less enterprising would have appeared impracticable. The difficulties he had to overcome were numerous, particularly in the operative department of preparing, melting, annealing, grinding, and polishing a mass of metal that was too unwieldy to be moved without the aid of mechanical powers. At length, however, all difficulties having been overcome, this magnificent instrument was completed, with all its complicated apparatus, and erected for observation, on the 2<sup>d</sup> of August, 1789, and on the same day the sixth satellite of Saturn was detected, as a prelude to still further discoveries which were afterwards made by this instrument in the celestial regions.

It would be too tedious to attempt a description of all the machinery and apparatus connected with this noble instrument. The reader who wishes to peruse a minute description of the stairs, ladders, platform, rollers, and of every circumstance relating to joiner's work, carpenter's work, smith's work, and other particulars connected with the formation and erection of this telescope, will find the details recorded in the 85th volume of the Philosophical Transactions of the Royal Society of London for 1795, in which there are sixty-three pages of letter-press, and eighteen plates illustrative of the subject. I shall content myself with giving a short outline of the essential parts belonging to this instrument.

The *tube* of this telescope is made of rolled or sheet iron, joined together without rivets; the thickness of the sheets is somewhat less than  $\frac{1}{36}$ th part of an inch, or 14 pounds weight for a square foot. Great care was taken that the cylindrical form should be secured, and the whole was coated over three or four times with paint, inside and outside, to secure it against the damp. This tube was removed from the place in which it was formed by 24 men, divided into six sets, so that two men on each side, with a pole 5 feet long in their hands, to which was affixed a piece of coarse cloth 7 feet long, going under the tube, and joined to a pole 5 feet long in the hands of two other men, assisted in carrying the tube. The length of this tube is 39 feet 4 inches, the diameter 4 feet 10 inches; and, on a moderate computation, it was ascertained that a wooden tube of proper dimensions would have exceeded an iron one in weight by at least 3000 pounds. Reckoning the circumference of the tube 15 feet, its length  $39\frac{1}{2}$  feet, and 14 lbs. for the weight of a square foot, it must have contained 590 square feet, and weighed 8260 pounds. Various hoops were fixed within the tube, and longitudinal bars of iron connecting some of them are attached to the two ends of the tube, by way of bracing the sheets, and preserving the shape perfect, when the pulleys are applied to give the necessary elevation at the upper end, and that the speculum may be kept secure at the lower end. The lower end of the tube is firmly supported on rollers, that are capable of being moved forward or backward by a double rack, connected with a set of wheels and pinions. By an adjustment at the lower extremity of the tube, the speculum is turned to a small inclination, so that the line of collimation may not be coincident with the longitudinal axis of the tube, but may cross the tube diagonally, and meet the eye in the air at about two inches from the edge of the tube, which is the peculiarity of the con-

struction that supersedes the necessity of applying a second reflector. Hence no part of the head of the observer intercepts the incident rays, and the observation is taken with the face looking at the speculum, the back being turned to the object to be observed.

The large speculum is inclosed in a strong iron ring, braced across with bars of iron, and an inclosure of iron, and ten sheets make a case for it. It is lifted by three handles of iron attached to the sides of the ring, and is put into, and taken out of, its proper place in the tube by the help of a movable crane, running on a carriage, which operation requires great care. The speculum is made of a metallic composition, and is  $49\frac{1}{2}$  inches in diameter; but the concave polished surface is only 48 inches, or 4 feet in diameter. Its thickness is  $3\frac{1}{2}$  inches; and when it came from the cast its weight was 2118 pounds. The metals for its formation were procured at a warehouse in Thames street, London, where they kept ingots of two kinds ready made, one of white and the other of bell-metal; and it was composed of two ingots of bell-metal for one of white. It was not to be expected that a speculum of such large dimensions could have a perfect figure imparted to its surface, nor that the curve, whatever it be, would remain identically the same in changes of temperature; therefore we are not surprised when we are told that the magnifying powers used with this telescope seldom exceeded 200, the quantity of light collected by so large a surface being the principal aim of the maker. The raising of the balcony, on which the observer stands, and the sliding of the lower end of the tube, in which the speculum rests, are effected by separate tackles, and require only occasional motions; but the elevation of the telescope requires the main tackle to be employed, and the motion usually given in altitude at once was two degrees; the breadth of the zone in which the observations were made, as the motion of the sphere in right ascension brought the objects into view. A star, however, could be followed for about a quarter of an hour. Three persons were employed in using this telescope, one to work the tackle, another to observe, and a third to mark down the observations. The elevation was pointed out by a small quadrant fixed to the main tube, near the lower end, but the polar distance was indicated by a piece of machinery, worked by a string, which continually indicated the degree and minute on a dial in the small house adjoining, while the time was shown by a clock in the same place, Miss Herschel performing the office of registrar.

At the upper end the tube is open, and directed to the part of the heavens intended for observation, and the observer, standing on the foot-board, looks down the tube, and perceives the object by rays reflected from the speculum through the eyeglass at the opening of the tube. When the telescope is directed to any objects near the zenith, the observer is necessarily at an elevation of at least 40 feet from the ground. Near the place of the eyeglass is the end of a tin pipe, into which a mouthpiece may be placed, so that, during an observation, a person may direct his voice into this pipe, while his eye is at the glass. This pipe, which is  $1\frac{1}{2}$  inch in diameter, runs down to the bottom of the tube, where it goes into a turning joint, thence into a drawing tube, and out of this into another turning joint, from whence it proceeds, by a set of sliding tubes, toward the front of the foundation timber. Its use is to convey the voice of the observer to his assistants, for at the last place it divides itself into two branches,

one going into the observatory, the other into the workman's room, ascending in both places through the floor, and terminates in the usual shape of speaking trumpets. Though the voice passes in this manner through a tube, with many inflections, and through not less than 115 feet, it requires very little exertion to be well understood.

To direct so unwieldy a body to any part of the heavens at pleasure, many mechanical contrivances were evidently necessary. The whole apparatus rests upon rollers, and care was previously taken of the foundation in the ground. This consists of concentric brick walls, the outermost 42 feet, the innermost 21 feet in diameter, 2 feet 6 inches deep under ground, 2 feet 3 inches broad at the bottom, and 1 foot 2 inches at the top, capped with paving stones 3 inches thick, and  $12\frac{3}{4}$  inches broad.

In the center is a large post of oak, framed together with braces under ground, and walled fast to brickwork to make it steady. Round this center the whole frame is moved horizontally by means of 20 rollers, 12 upon the outer and 8 upon the inner wall. The vertical motion is given to the instrument by means of ropes and pulleys, passing over the main beam supported by the ladders. These ladders are 49 feet long, and there is a movable gallery with 24 rollers to ease its motion. There is a staircase intended for persons who wish to ascend into the gallery without being obliged to go up the ladder. The ease with which the horizontal and vertical motions may be communicated to the tube may be conceived from a remark of Sir W. Herschel, that in the year 1789 he several times observed Saturn, two or three hours before and after its meridian passage, with one single person to continue, at his directions, the necessary horizontal and vertical motions.

By this telescope the sixth and seventh satellites of Saturn were discovered, only one of which is within the reach of the 20 feet reflector, or even of a 25 feet instrument. The discovery of the satellites of the planet Uranus, however, was made by the 20 feet reflector, but only after it had been converted from the Newtonian to the Herschelien construction, which affords a proof of the superiority of the latter construction over the former when the same speculum is used. Never had the heavens before been observed with so extraordinary an instrument as the forty-foot reflector. The nebulosities which are found among the fixed stars in various regions of the heavens appeared almost all to resolve themselves into an innumerable multitude of stars: others, hitherto imperceptible, seemed to have acquired a distinct light. On the entrance of Sirius into the field of the telescope, the eye was so violently affected that stars of less magnitude could not immediately after be perceived, and it was necessary to wait for 20 minutes before these stars could be observed. The ring of Saturn had always before ceased to be visible when its plane was directed toward the earth; but the feeble light which it reflects in that position was enough for Herschel's instrument, and the ring, even then, still remained visible to him.

It has been generally considered that this telescope was capable of carrying a power of 6000 times; and, perhaps, for the purpose of an experiment, and for trying its effect on certain objects, such a power may have been applied, in which case the eyeglass must have been only  $\frac{2}{25}$ ths of an inch focal distance, or somewhat less than  $\frac{1}{12}$ th of an inch. But such a power could not be generally applied with any good effect to the planetary bodies, and I question much

whether any power above 1000 times was ever generally used; for it is the quantity of light which the telescope collects, more than the magnifying power, that enables us to penetrate, with effect, into the distant spaces of the firmament; and hence, as above stated, the power seldom exceeded 200, which, on account of the large diameter of the speculum, would enable the instrument to penetrate into the distant celestial spaces perhaps farther than if a power of as many thousands of times had been applied.

Sir John Herschel, who inherits all the science, skill, and industry of his father, some time ago ground and polished a new speculum for the 20 feet tube, formerly noticed, which is connected with a stand, pulleys, and other appendages similar to those above described, though of smaller dimensions. This telescope shows the double stars exceedingly well-defined, and was one of the principal instruments used in forming his catalogue of these objects which was presented to the Royal Society, in conjunction with that of Sir James South, about the year 1828. I suppose it is likewise the same telescope with which Sir John lately made his sidereal observations at the Cape of Good Hope.

### SECTION III.

#### RAMAGE'S LARGE REFLECTING TELESCOPE.

THE largest *front view* reflecting telescope in this country, next to Herschel's 40 feet instrument, is that which was erected at the Royal Observatory at Greenwich in the year 1820, by Mr. Ramage of Aberdeen. The diameter of the concave reflector is 15 inches, and its focal length 25 feet. It is erected on machinery which bears a certain resemblance to that of Herschel's, which we have now described, but the mechanical arrangements are greatly simplified, so that the instrument is manageable by an observer without an assistant. The tube is composed of a twelve-sided prism of deal  $\frac{5}{8}$ ths of an inch thick. At the mouth is a double cylinder of different diameters on the same axis; around this a cord is wound by a winch, and passes up from the small cylinder, over a pulley, and down through another pulley on to the large cylinder. When the winch, therefore, is turned to raise the telescope, the endless cord is unwound from the smaller cylinder and wound on to the larger, the difference of the size of the two cylinders will be double the quantity raised, and a mechanical force to any extent may thus be obtained, by duly proportioning the diameters of the two cylinders: by this contrivance the necessity of an assistant is superseded. The view through this instrument first astonished those observers who had not been accustomed to examine a heavenly body with a telescope possessing so much light, and its performance was deemed quite extraordinary. But when the first impression had subsided, and different trials had been made in different states of the atmosphere, it was discovered that the central portion of the speculum was more perfectly figured than the ring bordering on the extreme edges. When the aperture was limited to ten or twelve inches, the performance as to the distinctness in its defining power was greatly improved, and the light was so brilliant that the astronomer royal was disposed to entertain an opinion that it might equal that of a good achromatic refractor of the same dimensions. When, however, very small

and obscure objects are to be observed, the whole light of the entire aperture may be used with advantage on favorable evenings.

The eyepieces adapted to this telescope have powers which magnify the object linearly from 100 to 1500 times, which are competent to fulfill all the purposes of vision when cleared of aberration. When the telescope is placed in the plane of the meridian, and elevated, together with the gallery, into any required altitude, the *meridional sweeps*, formerly practiced by Sir W. Herschel, and continued by Sir John with great success, in the examination of double stars and nebula, may be managed with great ease.

Mr. Ramage had a telescope of about the same size erected in an open space in Aberdeen, which I had an opportunity of inspecting when I paid a visit to that gentleman in 1833, but cloudy weather prevented my obtaining a view of any celestial bodies through it. He showed me at that time two or three large speculums, from 12 to 18 inches in diameter, which he had finished some time before, and which appeared most beautifully polished. He told me, too, that he had ground and polished them simply with his hand, without the aid of any machinery or mechanical power: a circumstance which, he said, astonished the opticians of London when it was stated, and which they considered as almost incredible. His experience in casting and polishing metals of various sizes during a period of 15 or 16 years qualified him to prepare specula of great luster, and with an unusually high polish. It has been asserted that a fifty feet telescope by Ramage of 21 inches aperture, was intended to be substituted for the 25 feet instrument erected at Greenwich, and the speculum, it is understood, was prepared, and ready for use, provided the Navy Board was disposed to defray the expense of carrying the plan into execution; but, unfortunately, this ingenious artist was unexpectedly cut off in the midst of his career; about the year 1835.

### SECTION IV.

#### THE AERIAL REFLECTOR CONSTRUCTED BY THE AUTHOR.

A PARTICULAR description of this telescope was given in the "Edinburgh New Philosophical Journal" for April—July, 1826, conducted by Professor Jameson, the greater part of which was copied in the "London Encyclopædia," under the article *Telescope*. From this description I shall endeavor to condense a brief account of this instrument, with a few additional remarks.

About the year 1822, an old speculum 27 inches in focal length, very imperfectly polished, happened accidentally to come into my possession, and feeling no inclination to fit it up in the Gregorian form, I adopted the resolution of throwing aside the small speculum, and attempting the *front view*, notwithstanding the uniform assertion of opticians that such an attempt in instruments of a small size is impracticable. I had some ground for expecting success in this attempt from several experiments I had previously made, particularly from some modifications made in the construction of astronomical eyepieces, which have a tendency to correct the aberration of the rays of light when they proceed somewhat obliquely from a lens or speculum. In the first instance, I placed the speculum at one end of a tube of the form of the segment of a cone, the end next the eye being



somewhat wider than that at which the speculum was fixed, and its length about an inch shorter than the focal distance of the mirror. A small tube for receiving the different eyepieces was fixed in the inside of the large tube at the end next the eye, and connected with an apparatus by which it could occasionally be moved either in a vertical or horizontal direction. With the instrument fitted up in this manner, I obtained some interesting views of the moon and of terrestrial objects; but, finding that one side of the tube intercepted a considerable portion of light from the object, I determined to throw aside the tube altogether, and to fit up the instrument on a different plan.

A short mahogany tube, about three inches long, was prepared, to serve as a socket for holding the speculum. To the side of this tube an arm was attached, about the length of the focal distance of the mirror, at the extremity of which a brass tube for receiving the eyepieces was fixed, connected with screws and sockets, by which it might be raised or depressed, and turned to the right hand or to the left, and with adjusting apparatus, by which it might be brought nearer to or farther from the speculum. Fig. 69 exhibits a general representation of the instrument in profile. *AB* is the short tube which holds the speculum; *CD* the arm which carries the eyetubes, which consists of two distinct pieces of mahogany; the part *D* being capable of sliding along the under side of *C*, through the brass sockets *E* *F*. To the under part of the socket, *F*, is attached a brass nut with a female screw, in which the male screw, *a* *b*, acts by applying the hand to the knob *c*, which serves for adjusting the instrument to distinct vision. *G* is the brass tube which receives the eyepieces. It is supported by a strong brass wire, *d* *e*, which passes through a nut connected with another strong wire, which passes through the arm *D*. By means of the nut *f*, this tube may be elevated or depressed, and firmly fixed in its proper position; and by the nut *d* it may be brought nearer to, or farther from, the arm *D*.

By the same apparatus it is also rendered capable of being moved either in a vertical or horizontal direction; but when it is once adjusted to its proper position, it must be firmly fixed, and requires no further attention. The eyepiece represented in this figure is the one used for terrestrial objects, which consists of the tubes belonging to a pocket achromatic telescope. When an astronomical eyepiece is used, the length of the instrument extends only to the point *I*. In looking through this telescope the right eye is applied to the point *H*, and the observer's head is understood to be uncovered, or, at least tightly covered with a thin cap. For those who use only the left eye, the arm would require to be placed on the opposite side of the tube, or the arm, along with the tube, be made to turn round 180 degrees.

Fig. 70 represents a front, or rather an oblique view of the instrument, in which the position of the speculum may be seen. All the specula which I fitted up in this form having been originally intended for Gregorian reflectors, have holes in their centers. The eyepiece is therefore directed to a point nearly equidistant from the hole to the left hand edge of the speculum, that is to the point *a*. In one of these instruments fitted up with a four feet speculum, the line of vision is directed to the point *b* on the op-

posite side of the speculum, but in this case the eyetube is removed farther from the arm than in the former case. The hole in the center of the speculum is obviously a defect in this construction of a reflecting telescope, as it prevents us from obtaining the full advantage of the rays which fall near the center of the mirror; yet the performance of the instruments, even with this disadvantage, is superior to what we should previously have been led to expect.

The principal nicety in the construction of the instrument consists in the adjustment and proper direction of the eyetube. There is only one position in which vision will be perfectly distinct. It must be neither too high nor too low; it must be fixed at a certain distance from the arm, and must be directed to a certain point of the speculum. This position must be ultimately determined by experiment when viewing terrestrial objects. A person unacquainted with this construction of the telescope would perhaps find it difficult, in the first instance, to make this adjustment; but were it at any time deranged, through accident or otherwise, I can easily make the adjustment anew in the course of a minute or two.

In pointing this telescope to the object intended to be viewed, the eye is applied at *K*, fig. 69, and looking along the arm, toward the eyepiece, until it nearly coincides with the object, it will, in most cases be readily found. In this way I can easily point this instrument to Jupiter or Saturn, or to any of the other planets visible to the naked eye, even when a power of 160 or 170 times is applied. When high magnifying powers, however, are used, it may be expedient to fix, on the upper part of the short tube on which the speculum rests, a finder, such as that which is used in Newtonian telescopes. When the moon is the object intended to be viewed, she may be instantly found by moving the instrument until her reflected image be seen from the eye-end of the telescope on the face of the mirror.

I have fitted up several instruments of the above description with specula of 16, 27, 35, and 49 inches focal distance. One of these, having a speculum of 27 inches focal length, and an astron-

Fig. 69.

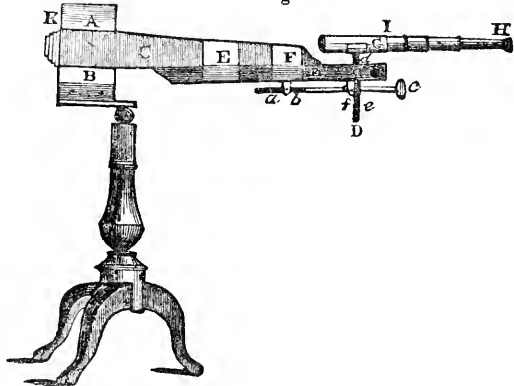

omical eyepiece, producing a magnifying power of about 90 times, serves as a good astronomical telescope. By this instrument the belts and satellites of Jupiter, the ring of Saturn, and the mountains and cavities of the moon, may be contemplated with great ease and distinctness. With a magnifying power of 35 or 40 times, terrestrial objects appear remarkably bright and well-defined. When compared with a Gregorian, the quantity of light

upon the object appears nearly doubled, and the image is equally distinct, although the speculum has several blemishes, and its surface is but imperfectly polished. It represents objects in their natural colors, without that dingy and yellowish tinge which appears when looking through a Gregorian. Another of these instruments is about

Fig. 70.

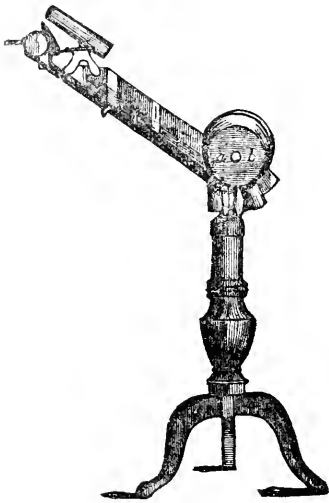

four feet long. The speculum which belongs to it is a very old one: when it came into my possession, it was so completely tarnished as scarcely to reflect a ray of light. After it was cleaned, it appeared to be scarcely half polished, and its surface is covered with yellowish stains which cannot be erased. Were it fitted up upon the Gregorian plan, it would, I presume, be of very little use, unless when a very small magnifying power was applied; yet in its present form it bears with distinctness a magnifying power of 130 times, and is equal in its performance to a  $3\frac{1}{2}$  feet achromatic. It exhibits distinct and interesting views of the diversities of shade, and of the mountains, vales, cavities and other inequalities of the moon's surface. With a power of about 50 times, and a terrestrial eyepiece, it forms an excellent telescope for land objects, and exhibits them in a brilliant and novel aspect. The smallest instrument I have attempted to construct on this plan is only  $5\frac{1}{2}$  inches focal distance, and  $1\frac{3}{4}$ ths of an inch in diameter. With a magnifying power of about 15 times, it shows terrestrial objects with distinctness and brilliancy. But I should deem it inexpedient to fit up any instrument of this description with specula of a shorter focal distance than 20 or 24 inches. The longer the focal distance, the more distinctness may be expected, although the aperture of the speculum should be comparatively small.

The following are some of the properties and advantages peculiar to this construction of the reflecting telescope:

1. It is *extremely simple*, and may be fitted up at a comparatively *small expense*. Instead of large and expensive brass tubes, such as are used in the Gregorian and Newtonian construction, little more is required than a short mahogany tube, two or three inches long, to serve as a socket for the speculum, with an arm connected with it about the focal length of the speculum. The expense of small specula, either plain or concave,

is saved, together with the numerous screws, springs, &c., for centering the two specula, and placing the small mirror parallel to the large one. The only adjustment requisite in this construction is that of the eyetube to the speculum; and, by means of the simple apparatus above described, it can be effected in the course of a few minutes. Almost the whole expense of the instrument consists in the price of the speculum and the eyepieces. The expense of fitting up the four feet speculum alluded to above, *exclusive of speculum and eyepiece*, but including mahogany tube and arm, brass sockets, screws, eyetube, brass joint, and a cast-iron stand, painted and varnished, did not amount to £1 8s. A Gregorian of the same size would have required a brass tube at least  $4\frac{1}{2}$  feet in length, which would cost five or six guineas, beside the apparatus connected with the small speculum, and the additional expense connected with the fitting up of the joint and stand requisite for supporting and steadying so unwieldy an instrument. While the one instrument would require two persons to carry it from one room to another, and would occupy a considerable space in an ordinary apartment, the other can be moved with the utmost ease, with one hand, to any moderate distance, and the space it occupies is extremely small.

2. It is *more convenient for viewing celestial objects at a high altitude than other telescopes*. When we look through a Gregorian reflector or an achromatic telescope of four or five feet in length, to an object elevated 50 or 60 degrees above the horizon, the body requires to be placed in an uneasy and distorted position, and the eye is somewhat strained while the observation is continued; but when viewing similar objects by the *Aerial Reflector*, we can either stand perfectly erect, or sit on a chair, with the same ease as we sit at a desk when reading a book or writing a letter. In this way, the surface of the moon or any other of the planets may be contemplated for an hour or two without the least weariness or fatigue. A delineation of the lunar surface may be taken with this instrument with more ease and accuracy than with any other instrument, as the observer can sketch the outline of the object by one eye on a tablet placed a little below the eyepiece, while the other eye is looking at the object. For the purpose of accommodating the instrument to a sitting or standing posture, a small table was constructed, capable of being elevated or depressed at pleasure, on which the stand of the telescope is placed. When the telescope is four or five feet long, and the object at a very high elevation, the instrument may be placed on the floor of the apartment, and the observer will stand in an erect position.

3. This instrument is considerably *shorter than a Gregorian telescope* whose mirror is of the same focal length. When an astronomical eyepiece is used, the whole length of the instrument is nothing more than the focal length of the speculum; but a Gregorian, whose large speculum is four feet focus, will be nearly five feet in length, including the eyepiece.

4. The *Aerial Reflector* far excels the Gregorian in brightness. The deficiency of light in the Gregorians is owing to the second reflection from the small mirror; for it has been proved by experiment that nearly the one-half of the rays of light which fall upon a reflecting surface is lost by a second reflection. The image of the object may also be presumed to be more correct, as it is not liable to any distortion by being reflected from another speculum.

5. There is *less tremor* in these telescopes than

**n. Gregorian reflectors.** One cause, among others, of the tremors complained of in Gregorians is, I presume, the formation of a second image at a great distance from the first, beside that which arises from the elastic tremor of the small speculum, when carried by an arm supported only at one end; but as the image formed by the speculum, in the aerial telescope is viewed *directly*, without being exposed to any subsequent reflection, it is not so liable to the tremors which are so frequently experienced in other reflectors. Notwithstanding the length of the arm of the four feet telescope above mentioned, a celestial object appears remarkably steady when passing across the field of view, especially when it is at a moderate degree of altitude; and it is easily kept in the field by a gentle motion applied to the arm of the instrument.

In prosecuting my experiments in relation to these instruments, I wished to ascertain what effect might be produced by using a *part of a speculum* instead of the whole. For this purpose, I cut a speculum, three feet in focal length, through the center, so as to divide it into two equal parts, and fitted up each part as a distinct telescope, so that I obtained two telescopes from one speculum. In this case, I found that each half of the speculum performed nearly as well as the whole speculum had done before; at least, there appeared to be *no very sensible* diminution in the *brightness* of the object, when viewed with a moderate power, and the image was equally accurate and distinct; so that if *economy* were a particular object aimed at in the construction of these instruments, two good telescopes might be obtained from one speculum; or if a speculum happened to be broken accidentally into large fragments, one or more of the fragments may be fitted up on this principle to serve as a tolerably good telescope.

From the experiments I have made in reference to these instruments, it is demonstrable that a *tube is not necessary* in the construction of a reflecting telescope—at least, on the principle now stated—whether it be used by day or by night, for terrestrial or celestial objects; for I have frequently used these telescopes in the open air in the day-time, without any inconvenience from extraneous light. Therefore, were a reflecting telescope of 50 or 60 feet in length to be constructed, it might be fitted up at a comparatively small expense, after the expense of the metallic substances, and of casting, grinding, and polishing the speculum is defrayed. The largest instrument of this description which has hitherto been constructed is the 40 feet reflector of Sir W. Herschel. This complicated and most unwieldy instrument had a tube of rolled or sheet iron 39 feet 4 inches in length, about 15 feet in circumference, and weighed about 8000 pounds. Now I conceive that such enormous tubes, in instruments of such dimensions, are altogether unnecessary. Nothing more is requisite than a short tube for holding the speculum. Connected with one side of this tube (or with both sides were it found necessary), two strong bars of wood, projecting a few feet beyond the speculum end, and extending in front as far as the focal length of the mirror, and connected by cross-bars of wood, iron, or brass, would be quite sufficient for a support to the eyepiece, and for directing the motion of the instrument. A telescope of 40 or 50 feet in length, constructed on this plan, would not require one-fifth of the expense, nor one-fourth of the apparatus and mechanical power for moving it to any required position, which were found necessary in the construction of Sir

W. Herschel's large reflecting telescope. The idea here suggested will perhaps be more readily appreciated by an inspection of fig. 71, where *A* is the short tube, *BC* and *DE* the two large bars or arms, connected with cross-bars, for the purpose of securing strength and steadiness. At *I* and *K*, behind the speculum, weights might be applied, if necessary, for counterbalancing the lever power of the long arm. *F* represents the position of the eyepiece, and *G H* the point and part of the pedestal on which the instrument is placed. With regard to telescopes of smaller dimensions, as from 5 to 15 feet in focal length—with the exception of the expense of the specula and eyepieces—they might be fitted up for a sum not greater than from 3 to 10 or 15 guineas.

Fig. 71.

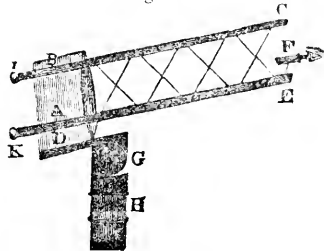

Were any person to attempt the construction of those telescopes, it is possible he might not succeed in his first attempts without more minute directions than I have yet given. The following directions may perhaps tend to guide the experimenter in adjusting the eye-tube to the speculum, which is a point that requires to be particularly attended to, and on which depends the accurate performance of the instrument. After having fixed the eyepiece nearly in the position it should occupy, and directed the instrument to a particular object, look along the arm of the telescope, from *K* (fig. 69), to the extremity of the eyepiece at *H*, and observe whether it nearly coincides with the object. If the object appear lower than this line of vision, the eyepiece must be lowered, and if higher, it must be raised, by means of the nuts and screws at *g d* and *f e*, until the object and the line of vision now stated nearly coincide. The eyepiece should be directed as nearly perpendicular to the front of the speculum as possible, but so that the reflected image of one's head from the mirror shall not interfere to obstruct the rays from the object. An object may be seen with an approximate degree of distinctness, but not accurately, unless this adjustment be pretty accurately made. The astronomical eyepieces used for these telescopes are fitted with a brass cap, which slides on the end next the eye, and is capable of being brought nearer to or farther from the first eyeglass. In the center of this cap, next the eye, is a small hole, about the 1-40th or 1-50th of an inch diameter, or about as wide as to admit the point of a pin or a moderate-sized needle. The distance of this hole from the lens next the eye must be adjusted by trial, until the whole field of view appears distinct. A common astronomical eyepiece, without this addition, does not answer well. I find, by experience, that terrestrial eyepieces, such as those used in good achromatic telescopes, are, on the whole, best adapted to this construction of a reflecting telescope.

I have sometimes used these instruments for the purpose of viewing perspective prints, which

they exhibit in a beautiful and interesting manner. If a colored perspective be placed at one end of a large room or gallery, and strongly illuminated either by the sun or by two candles, and one of the reflectors, furnished with a small *magnifying power*, placed at the opposite end of the room, the representation of a street or a landscape will be seen in its true perspective, and will appear even more pleasant and interesting than when viewed through the common *optical diuina machine*. If an inverting eyepiece be used—which is most eligible in this experiment—the print, of course, must be placed in an inverted position.

That reflecting telescopes of the descriptions now stated are original in their construction, appears from the uniform language of optical writers, some of whom have pronounced such attempts to be altogether impracticable. Sir David Brewster, one of the latest and most respectable writers on this subject, in the "Edinburgh Encyclopaedia," art. *Optics*, and in the last edition of his *Appendix to Ferguson's Lectures*," has the following remarks: "If we could dispense with the use of the small specula in telescopes of moderate length, by inclining the great speculum, and using an oblique, and, consequently, a *distorted* reflection, as proposed first by Le Maire, we should consider the Newtonian telescope as perfect; and on a large scale, or when the instrument exceeds 20 feet, it has undoubtedly this character, as nothing can be more simple than to magnify, by a single eyeglass, the image formed by a single speculum." As the *front view* is quite impracticable, and, indeed, has never been attempted in instruments of a small size, it becomes of great practicable consequence to remove as much as possible the evils which arise from the use of a small speculum," &c.

The instruments now described have effectuated, in some degree, the desirable object alluded to by this distinguished philosopher, and the mode of construction is neither that of Sir W. Herschel's front view, nor does it coincide with that proposed by Le Maire, which appears to have been a mere hint that was never realized in the construction of reflecting telescopes of a small size. The simplicity of the construction of these instruments, and the excellence of their performance, have been much admired by several scientific gentlemen and others to whom they have been exhibited. Prior to the description of them in the Edinburgh Philosophical Journal, they were exhibited in the Calton Hill Observatory, Edinburgh, in the presence of Professor Wallace and another gentleman, who compared their performance with that of an excellent Gregorian. As this instrument is distinguished from every other telescope in being used without a tube, it has been denominated "*The Aerial Reflector*."

## SECTION V.

### EARL OF ROSSE'S REFLECTING TELESCOPES.

This nobleman, unlike many of his contemporaries, has, for a considerable number of years past, devoted his attention to the pursuits of science, and particularly to the improvement of reflecting telescopes. He is evidently possessed of high mathematical attainments, combined with an uncommon degree of mechanical ingenuity. About 14 or 15 years ago, he engaged in various experiments with the view of counteracting the effects of the spherical aberration of the specula of re-

flecting telescopes, which imperfection, if it could be completely remedied, would render the reflecting telescope almost a perfect instrument, as it is not affected by the different refrangibility of the rays of light. His method, we believe, consisted in forming a large speculum of two or three separate pieces of metal, which were afterward accurately combined into one—a central part, which was surrounded by one or two rings ground on the same tool. When the images formed by the separate pieces were made exactly to coincide, the edge of the object toward which the whole speculum was directed was then found to be as distinct as either image had been when separate; but, at the period referred to, a sufficient number of experiments had not been made to determine that his lordship had completely accomplished the object he intended.

Great interest, however, has of late been excited by the improvements which his lordship has made in the formation of specula. Sir W. Herschel never made public the means by which he succeeded in giving such gigantic development to the reflecting telescope, and therefore the construction of a large reflector has been considered as a perilous adventure; but, according to a report of Dr. Robinson, of Armagh, to the Irish Academy, the Earl of Rosse has overcome the difficulties which have hitherto been met with, and carried to an extent which even Herschel himself did not venture to contemplate, the illuminating power of this telescope, along with a sharpness of definition little inferior to that of the achromatic; and it is scarcely possible, he observes, to preserve the necessary sobriety of language in speaking of the moon's appearance with this instrument, which Dr. Robinson believes to be the most powerful ever constructed. The difficulty of constructing large specula, and of imparting to them the requisite degree of polish, has hitherto been considered so great, that from eight to twelve inches diameter, has been, in general, their utmost size; indeed, except with the greatest reluctance, London opticians would not accept of orders for specula of more than nine inches in diameter. It appears, however, that the Earl of Rosse has succeeded, by a peculiar method of molding, in casting object-mirrors of true *speculum metal* of three feet in diameter, and of a weight exceeding 17 cwt. He is about to construct a telescope, the speculum of which is six feet in diameter, fifty feet focal distance, and of the weight of four tons; and from what he has already accomplished, it is not doubted that he possesses the power to carry his design into effect. These great masses of metal, which, in the hands of all other makers of specula, would have been as untractable as so much unannealed flint glass, the Earl of Rosse has farther succeeded in bringing to the highest degree of polish, and the utmost perfection of curvature, by means of machinery. The process is conducted under water, by which means those variations of temperature, so fatal to the finest specula hitherto attempted, are effectually guarded against. To convince Dr. Robinson of the efficacy of this machinery, the Earl took the three-foot speculum out of its telescope, destroyed its polished surface, and placed it under the mechanical polisher. In six hours it was taken out with a perfect new surface as bright as the original. Under the old system of hand polishing, it might have required months, and even years to effect this restoration. Even before achieving these extraordinary triumphs on the solid substance, his lordship had constructed a six-foot reflector by covering a curved surface of

brass with squares of the true speculum metal, which gave an immense quantity of light, though subject to some irregularities, arising from the number of joinings necessary in such a mosaic work. Of the performance of his lordship's great telescope, mounted with this reflector, those who have seen it speak in terms of high admiration; but in reference to the smaller and more perfect instrument, furnished with the solid three-foot speculum, the language of the Armagh astronomer assumes a tone of enthusiasm, and even of sublimity. By means of this exquisite instrument, Dr. Robbison and Sir J. South, in the intervals of a rather unfavorable night, saw several new stars, and corrected numerous errors of other observers. For example, the planet Uranus, supposed to possess a ring similar to that of Saturn, was found not to have any such appendage; and these nebulae, hitherto regarded, from their apparently circular outline, as "condensing systems," appeared, when tested by the three-foot speculum, to be very far indeed from presenting a globular appearance, numerous offshoots and appendages, invisible by other telescopes, appearing in all directions radiating from their edges. Such discoveries, which reflect great honor on the Earl of Rosse, will doubtless have great effect on the interests of astronomical science.\*

## SECTION VI.

### REFLECTING TELESCOPES WITH GLASS SPECULA.

AFTER making a variety of experiments with aerial telescopes constructed of metallic specula of different focal lengths, I constructed a telescope on the same plan with a concave glass mirror. Having obtained a fragment of a very large convex mirror which happened accidentally to have been broken, I caused the convex side to be foliated or silverized, and found its focal length to be about 27 inches. This mirror, which was about five inches diameter, I placed in one of the aerial reflectors instead of the metallic speculum, and tried its effects with different terrestrial eyepieces. With a power of about 35 or 40 times, it gave a beautiful and splendid view of distant terrestrial objects, the quantity of light reflected from them being considerably greater than when a metallic speculum was used, and they appeared, on the whole, well-defined. The only imperfection—as I had foreseen—consisted in a double image being formed of objects which were remarkably bright and white, such as a lighthouse whitened on the outside, and strongly illuminated by the sun. One of the images was bright, and the other faint. This was obviously owing to the two reflections from the two surfaces of the mirror—one from the convex silverized side, and the other from the concave side next the eye, which produced the faint image—which circumstance has been generally considered as a sufficient reason for rejecting the use of glass specula in telescopes. But, although very bright objects exhibited a double image, almost all the other objects in the terrestrial landscape appeared quite distinct and without any secondary image, so that a common observer could scarcely have noticed any imperfection. When the instrument, however, was directed to celestial objects, the secondary

image was somewhat vivid, so that every object appeared double. Jupiter appeared with two bodies, at a little distance from each other, and his four satellites appeared increased to eight. The moon likewise appeared as a double orb, but the principal image was distinct and well-defined. Such a telescope, therefore, was not well adapted for celestial observations, but might answer well enough for viewing terrestrial objects.

Considering that the injurious effects of the secondary image arose from the images reflected from the two surfaces being formed near the same point, and at nearly the same focal distance, I formed a plan for destroying the secondary image, or at least counteracting its effects, by forming the concavity of the mirror next the eye of a portion of a sphere *different* from that of the convex side which was silverized, and from which the principal image is formed; but, for a long time, I could find no opticians possessed of tools of a sufficient length of radii for accomplishing my design. At length a London working optician undertook to finish a glass speculum according to my directions, which were, that the convex surface of the mirror should be ground on a tool which would produce a focal distance by reflection of about four feet, and that the concave surface should have its focal distance at about three feet three inches, so that the secondary image might be formed at about nine inches within the focal distance of the silverized side, and not interfere to disturb the principal image; but, either from ignorance or inattention, the artist mistook the radius for the half radius of concavity, and the speculum turned out to be only 23 inches focal distance by reflection. This mirror was fitted up as a telescope on the aerial plan, and I found, as I expected, the secondary image completely destroyed. It produced a very beautiful and brilliant view of land objects, and even the brightest objects exhibited no double image. The mirror was nearly five inches in diameter, but the image was most accurately defined when the aperture was contracted to about three inches. It was fitted with a terrestrial eyepiece which produced a magnifying power of about 25 times. When directed to the moon, it gave a very distinct and luminous view of that orb, without the least appearance of a secondary image; but as the focal distance of the speculum was scarcely half the length I had prescribed, I did not apply to it any high astronomical powers, as I find that these can only be applied with effect, in this construction, to a speculum of a considerable focal length. Happening to have at hand a convex lens ten feet focal length and four inches in diameter, the one side of which had been ground to a certain degree of concavity, I caused the convex side to be foliated, which produced a focus by reflection at 13½ inches distant. To this mirror I applied terrestrial powers of 15 and 24 with considerable distinctness. The power of 15 produced a very brilliant and distinct view of land objects. Had the mirror been at least three times the focal length, it would have formed an excellent telescope with the same aperture.

## SECTION VII.

### A REFLECTING TELESCOPE, WITH A SINGLE MIRROR AND NO EYEPIECE.

\* A particular account of the Earl of Rosse's fifty-foot reflector, which is now finished, is given in the Appendix.

ON the same principle as that by which a refracting telescope may be constructed by means

of a single lens, as represented fig. 51 (page 68), we may form a telescope by reflection with a single mirror and without an eyepiece. Let *A B*, fig. 72, represent a large concave speculum, and

Fig. 72.

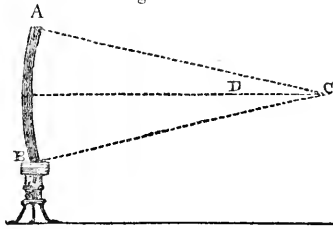

*C* its focus: if an eye be placed at *D*, about eight or ten inches within the focal point *C*, all the objects in the direction of *C*, or behind the spectator, will be seen magnified by reflection on the face of the mirror, and strongly illuminated. The magnifying power, in this case, will be nearly in the proportion of the focal length of the mirror to the focal length of the eye for near objects. If, for example, the focal distance of the mirror be eight feet, and the distance from the eye at which we see near objects most distinctly be eight inches, the magnifying power will be in the ratio of 8 to 96, or 12 times. I have a glass mirror of this description, whose focal length is four feet eight inches, and diameter six inches, which magnifies distant objects about seven times, takes in a large field of view, and exhibits objects with great brilliancy. It presents a very distinct picture of the moon, showing the different streaks of light and shade upon her surface, and in some cases shows the larger spots which traverse the solar disc. This mode of viewing objects is extremely easy and pleasant, especially when the mirror is of a large diameter, and the observer is at first struck and gratified with the novel aspect in which the objects appear.

Were a concave mirror of this description—whether of glass or of speculum metal—to be formed to a very long focus, the magnifying power would be considerable. One of 50 feet focal length, and of a corresponding diameter, might produce a magnifying power, to certain eyes, of about 75 times; and from the quantity of light with which the object would be seen, its effect would be much greater than the same power applied to a common telescope. Sir W. Herschel states that, on one occasion, by looking with his naked eye on the speculum of his 40 feet reflector, without the interposition of any lens or mirror, he perceived distinctly one of the satellites of Saturn, which requires the application of a considerable power to be seen by an ordinary tele-

scope. Such an instrument is one of the most simple forms of a telescope, and would exhibit a brilliant and interesting view of the moon, or of terrestrial objects.

PRICES OF REFLECTING TELESCOPES.

1. Prices as stated by Messrs. W. and S. Jones, Holborn, London.

	£.	s.
A 4 feet, 7 inch aperture, Gregorian reflector, with the vertical motions upon a newly invented principle, as well as apparatus to render the tube more steady for observation according to the additional apparatus of small speculums eyepieces, micrometers, &c. from £80 to 3 feet long, mounted on a plain brass stand . . . . .	130	0
Ditto with rack-work motions, improved mountings and metals . . . . .	23	2
2 feet long, without rack-work, and with 4 magnifying powers, improved . . . . .	39	18
Ditto improved, with rack-work motions . . . . .	15	15
18 inch. on a plain stand . . . . .	22	1
12 inch ditto . . . . .	9	9
	6	6

2. Prices as stated by Messrs. Tulley, Islington.

	£.	s.
1 foot Gregorian reflector, on pillar and claw stand, metal 2½ inches diameter, packed in a mahogany box . . . . .	6	6
1½ foot ditto, on pillar and claw stand, metal 3 inches diameter, packed in a mahogany box . . . . .	11	11
2 feet ditto, metal 4 inches diameter . . . . .	16	16
Ditto with rack-work motions . . . . .	25	4
3 feet ditto, metal 5 inches diameter, rack-work motions . . . . .	42	0
4 feet ditto, metal 7 inches diameter, on a tripod stand with center of gravity motion . . . . .	105	0
6 feet ditto, metal 9 inches diameter . . . . .	210	0
7 feet <i>Newtonian</i> , 6 inches aperture . . . . .	105	0
12 feet ditto, metal 12 inches diameter . . . . .	525	0

Prices as stated by Mr. G. Dollond, St. Paul's Churchyard.

	£.	s.
Reflecting telescopes, 14 inches long, in a mahogany box . . . . .	9	9
Ditto 18 inches . . . . .	12	12
Ditto 2 feet . . . . .	18	18
Ditto with 4 different powers, and rack-work stand supporting the telescope in the center of gravity . . . . .	36	15
Ditto 3 feet, with ditto . . . . .	50	0

4. Prices of single speculums and reflecting telescopes, as made by Mr. Grub, Charlemont Bridge-works, Dublin.

NEWTONIAN TELESCOPES.					
Diameter in inches.	Focal length in feet.	Price of mirrors alone.		Price of telescope complete without stand.	
		£.	s.	£.	s.
7	7	17	10	27	10
9	10	25	0	40	0
12	12	60	0	90	0
15	15	120	0	170	0
18	18	200	0	260	0

GREGORIAN TELESCOPES.					
Diameter in inches.	Focal length in feet.	Price of mirrors alone.		Price of telescope complete without stand.	
		£.	s.	£.	s.
6	3	17	10	25	0
7	3	25	0	34	0
9	4½	35	0	50	0
12	7	70	0	100	0
15	9	150	0	200	0
18	12	240	0	300	0

## ON THE EYEPIECES OF TELESCOPES.

Although the performance of telescopes chiefly depends on the goodness of the object-glass, or the object-speculum of the instrument, yet it is of considerable importance, in order to distinct vision, and to obtain a large and uniformly distinct field of view, that the eyepiece be properly constructed. The different kinds of eyepieces may be arranged into two general divisions, *Astronomical* and *Terrestrial*.

1. *Astronomical Eyepieces*.—The most simple astronomical eyepiece is that which consists of a single convex lens; and when the focal distance of this lens, and that of the object-glass of the instrument, is accurately ascertained, the magnifying power may be nicely determined by dividing the focal length of the object-glass by that of the eyeglass; but as the pencil of white light transmitted by the object-glass will be divided by the eyeglass into its component colors, the object will appear bordered with colored fringes, and the distinctness of vision consequently injured; beside, the spherical aberration, when a single lens is used, is much greater than when two or more glasses are employed; hence astronomical eyepieces are now formed by a combination of at least two lenses.

The combination of lenses now generally used for astronomical purposes is that which is usually denominated the *Huygenian Eyepiece*, having been first proposed by the celebrated Huygens as a great improvement on the single lens eyepiece. The following figure (73) represents a section of this eyepiece: Let *AB* be a compounded pencil of white light proceeding from the object-glass; *BF* a plano-convex field-glass, with its plane side next the eyeglass *E*. The red rays of the pencil *AB*, after refraction, would cross the axis in *R*, and the violet rays in *V*; but, meeting the eyeglass *E*, the red rays will be refracted to *O*, and the violet nearly in the same direction, when they will cross each other about the point *O* in the axis, and unite. The distance of the two glasses *FE*, to produce this correction, when made of crown glass, must be equal to half the sum of their focal distances nearly; for example, suppose the focal distance of the largest, or field-glass, to be three inches, and the focal distance of the lens next the eye one inch, the two lenses should be placed exactly at the distance of two inches, the sum of their focal length being four, the half of which is two. In other words, the glass next the eye should be placed as much *within* the focus of the field-glass as is equal to its own focal distance. The focal length of a single lens that has the same magnifying power as this compound eyepiece, is equal to twice the product of the focal lengths of the two lenses divided by the sum of the same numbers; or, it is equal to half the focal length of the field-glass. Thus, in reference to the preceding example, twice the product of the focal length of the two lenses is equal to six, and their sum is four. The former number divided by the latter produces a quotient of  $1\frac{1}{2}$ , which is the focal length of a single lens, which would produce the same magnifying power as the eyepiece; and  $1\frac{1}{2}$  is just half the focal length of the field-glass. The proportion of the focal lengths of the two lenses to each other, according to Huygens, should be as three to one; that is, if the field-glass be  $4\frac{1}{2}$  inches, the eyeglass should be  $1\frac{1}{2}$ , and this is the proportion most generally adopted; but some opticians have recommended that the proportion should be as three to two. Boscovich recommended two simi-

lar lenses; and in this case the distance between them was equal to half the sum of their focal distances, as in the Huygenian eyepiece.

Fig. 73.

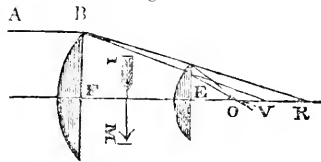

The image is formed at *IM*, at the focal distance of the lens next the eye, and at the same distance from the field-glass. When distinct vision is the principal object of an achromatic telescope, the two lenses are usually both plano-convex, and fixed with their curved faces toward the object-glass, as in the figure. Sometimes, however, they consist of what is called *crossed* lenses, that is, lenses ground on one side to a short focus, and on the other side to a pretty long focus, the sides with the deepest curves being turned toward the object-glass. A diaphragm, or aperture of a proper diameter, is placed at the focus of the eye-lens where the image formed by the object-glass falls, for the purpose of cutting off the extreme rays of the field-lens, and rendering every part of the field of view equally distinct. This is likewise the form of the eyepiece generally applied to Gregorian reflectors. In short, when accurately constructed, it is applicable to telescopes of every description. This eyepiece, having the image viewed by the eye behind the inner lens, is generally called the *negative* eyepiece, and is that which the optical instrument makers usually supply, of three or four different sizes, for so many magnifying powers, to be applied to different celestial objects, according to their nature, or the state of the atmosphere in which they are used.

*Ramsden's Eyepiece*.—There is another modification of lenses, known by the name of the *Positive*, or *Ramsden's Eyepiece*, which is much used in transit instruments, and telescopes which are furnished with micrometers, and which affords equally good vision as the other eyepiece. In this construction the lenses are plano-convex, and nearly of the same focus, but are placed at a distance from each other less than the focal distance

Fig. 74.

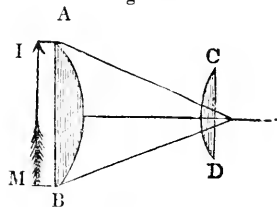

of the glass next the eye, so that the image of the object viewed is beyond both the lenses when measuring from the eye. The flat faces of the two lenses are turned into contrary directions in this eyepiece, one facing the object-glass, and the other the eye of the observer; and as the image formed at the focus of the object-glass lies parallel to the flat face of the contiguous lens, every part of the field of view is distinct at the same adjustment, or, as opticians say, there is a *flat field*, which, without a diaphragm, prevents distortion of the object. This eyepiece is represented in

fig. 74, where *AB* and *CD* are two plano-convex lenses, with their convex sides inward. They have nearly the same focal length, and are placed at a distance from each other equal to about two-thirds of the focal length of either. The focal length to an equivalent single lens is equal to three-fourths the focal length of either lens, supposing them to have equal focal distances. This eyepiece is generally applied when wires of spider's lines are used in the common focus, as the piece containing the lenses can be taken out without disturbing the lines, and is adjustable for distinct vision; and whatever may be the measure of any object given by the wire micrometer at the solar focus, it is not altered by a change of the magnifying power when a second eyepiece of this construction is substituted.

**Aberration of Lenses.**—In connection with the above descriptions, the following statements respecting the spherical aberration of lenses may not be inappropriate. Mr. John Dollond, in a letter to Mr. Short, remarks, that "the aberration in a single lens is as the cube of the refracted angle; but if the refraction be caused by two lenses, the sum of the cubes of each half will be a quarter of the refracted angle, twice the cube of one being a quarter of the cube of two. So three times the cube of one is only one-ninth of the cube of three," &c. Hence the indistinctness of the borders of the field of view of a telescope is diminished by increasing the number of lenses in an eyepiece. Sir J. Herschel has shown that if two plano-convex lenses are put together as in fig. 75, the aberration will be only 0.241, or one-fourth of that of a single lens in its best form. The focal length of the first of these lenses must be to that of the second as 1 to  $\frac{2}{3}$ . If their focal lengths are equal, the aberration will be 0.603, or nearly one-half. The spherical aberration, however, may be entirely destroyed by combining a meniscus and double convex lens, as shown in fig. 76, the convex sides being turned to the eye

Fig. 75.



Fig. 76.



when they are used as lenses, and to parallel rays when they are used as burning glasses. Sir J. Herschel has computed the following curvatures for such lenses:

Focal length of the convex lens . . .	+10.000
Radius of its first surface . . .	+ 5.833
Radius of its second surface . . .	-35.000
Focal length of the meniscus . . .	+17.29
Radius of its first surface . . .	+ 3.688
Radius of its second surface . . .	+ 6.294
Focal length of the compound lens . . .	+ 6.407

On the general principles above stated, a good astronomical eyepiece may be easily constructed with two proper lenses, either according to the plan of Huygens or that of Ramsden: and, from what has been now stated, it is demonstrably certain, that, in all cases where two glasses are properly combined, such an eyepiece is superior to a single lens both in point of distinctness and of the enlargement of the field of view. I lately fitted up an eyepiece, on Ramsden's principle, with two lenses, each about three inches focal length, and

$1\frac{3}{4}$ ths of an inch in diameter, placed at half an inch distant, with their convex surface facing each other, as in fig. 74, which forms an excellent eyepiece for an achromatic telescope six feet eight inches focal distance and four inches aperture, particularly for viewing clusters of stars, the Milky Way, and the large nebulae. The field of view is large, the magnifying power is only between 50 and 60 times, and the quantity of light being so great, every celestial object appears with great brilliancy, and it is, in general, much more preferable, when applied to the stars, than any of the higher powers. When applied to *Præsepe* in Cancer, it exhibits that group at one view, as consisting of nearly 100 stars, which exhibit a beautiful and most striking appearance.

It may appear a curious circumstance that any eyepiece which is good with a short telescope is also good with a long one, but that the reverse is not true; for it is found to be more difficult to make a good eyepiece for a short than for a long focal distance of the object-glass.

Celestial eyepieces are sometimes constructed so as to produce *variable powers*. This is effected by giving a motion to the lens next the eye, so as to remove it nearer to or farther from the field-lens; for at every different distance at which it is placed from the other lens, the magnifying power will either be increased or diminished. The greatest power is when the two lenses are nearly in contact, and the power diminishes in proportion to the distance at which the glass next the eye is removed from the other. The scale of distance, however, between the two lenses cannot be greater than the focal distance of the field, or inner glass; for if it were, the lenses would no longer form an eyepiece, but would be changed into an inverting opera-glass. For effecting the purpose now stated, the eyeglass is fixed in a tube, which slides upon an interior tube, on which is marked a scale of distances corresponding to certain magnifying powers; and in this way an eyepiece may be made to magnify about double the number of times when the lenses are in one position than when they are in another; as, for example, all the powers from 36 to 72 times may be thus applied, merely by regulating the distance between the two lenses. When the glasses are varied in this manner, the eyepiece becomes sometimes a *positive* eyepiece, like Ramsden's, and sometimes a *negative* one, like that of Huygens.

**Diagonal Eyepieces.**—The eyepieces to which we have now adverted, when adapted to refracting telescopes, both reverse and invert the object, and therefore are not calculated for showing terrestrial objects in their natural position: but as the heavenly bodies are of a spherical form, this circumstance detracts nothing from their utility. When the celestial object, however, is at a high altitude, the observer is obliged to place his head in a very inconvenient position, and to direct his eye nearly upward; in which position he cannot remain long at ease, or observe with a steady eye. To remedy this inconvenience, the diagonal eyepiece has been invented, which admits of the eye being applied at the side, or at the upper part of the eyepiece, instead of the end; and when such an eyepiece is used, it is of no importance in what direction the telescope is elevated, as the observer can then either sit or stand erect, and look down upon the object with the utmost ease. This object is effected by placing a flat piece of polished speculum metal at an angle of 45 degrees in respect to the two lenses of the eyepiece, which alters the direction of the converging rays, and forms an image which becomes erect with respect



to altitude, but is reversed with respect to azimuth; that is, in other words, when we look down upon the objects in the field of view, they appear erect; but that part of an object which is in reality on our right hand, appears on our left; and if it be in motion, its *apparent*, is opposite to its *real* motion; if it be moving toward the west, it will seem to move toward the east.

There are three situations in which the diagonal reflector in this eyepiece may be placed. It may be placed either, 1, before the eyepiece, or 2, behind it, or, 3, between the two lenses of which the eyepiece consists. The most common position of the reflector is between the lenses; and this may be done both in the negative and the positive eyepieces; but as the distance between the two lenses is necessarily considerable, to make room for the diagonal position of the reflector, the magnifying power cannot be great; otherwise a diagonal eyepiece of this construction remains always in adjustment, and is useful in all cases where a high power is not required. The preceding is a description and representation of a diagonal eyepiece of this kind in my possession.

In fig. 77, *AB* represents the plano-convex lens next the object, which is about 2 inches in focal length, and  $\frac{3}{4}$  of an inch in diameter; *CD*, a plain metallic speculum of an oval form, well polished, and placed at half a right-angle to the axis of the tube; and *EF*,

Fig 77.

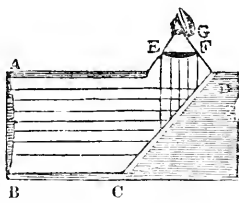

another plano-convex lens, about  $1\frac{1}{2}$  inch focal distance. The center of the speculum is about  $1\frac{1}{4}$ th of an inch from the lens *AB*, and about half or one-third of an inch from *EF*; so that this eyepiece is a *positive* one, on the principle proposed by Ramsden. The rays proceeding from the lens *AB*, and falling upon the speculum, are reflected in a perpendicular direction to the lens *EF*, where they enter the eye at *G*, which looks down upon the object through the side of the tube. The real size of this eyepiece is much about the same as that represented in the figure. When applied to an achromatic telescope of  $41\frac{1}{2}$  inches focal distance, it produces a magnifying power of 36 times, and exhibits a very beautiful view of the whole of the full moon. It likewise presents a very pleasing prospect of terrestrial objects, which appear as if situated immediately below us.

Another plan of the diagonal eyepiece is represented in Fig. 78, where the speculum is fixed *within* the sliding tube which receives the eyepiece, or immediately below it. The part of the tube *AB* slides into the tube of the telescope, *CD* is the speculum placed at half a right-angle to

Fig. 78.

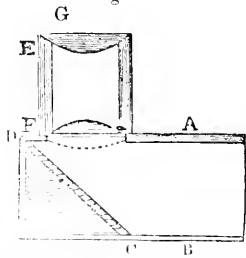

the axis of the tube, and *EF* the tube containing the lenses, which stands at right-angles to the position of the telescope, and slides into an exterior tube, and the eye is applied at *G*. This con-

struction of the diagonal eyepiece may be used with any eyepiece whatever, whether the Huygenian or that of Ramsden. It will admit of any magnifying power, and if several different eyepieces be fitted to the sliding tube, they may be changed at pleasure. This form of the diagonal eyepiece I therefore consider as the best and the most convenient construction, although it is not commonly adopted by opticians.

When any of these eyepieces are applied to a telescope, with the lens *E* on the upper part of it, we look down upon the object, if it be a terrestrial one, as if it were under our feet. If we turn the eyepiece round in its socket a quarter of a circle toward the left, an object directly before us in the south will appear as if it were in the west, and turned upside down. If, from this position, it is turned round a semicircle toward the right, and the eye applied, the same object will appear as if it were situated in the east, and inverted; and if it be turned round another quadrant, until it be directly opposite to its first position, and the eye applied from below, the object or landscape will appear as if suspended in the atmosphere above us. This eyepiece, therefore, is capable of exhibiting objects in a great variety of aspects, and the use of it is both pleasant and easy for the observer. But there is a considerable loss of light, occasioned by the reflection from the speculum, which is sensibly felt when very high powers are applied; and therefore, when very small stars are to be observed, such as some of those connected with double or triple stars, the observer should not study his own ease so much as the quantity of light he can obtain with a high power, which object is best attained with an ordinary eyepiece and a telescope of large aperture.

We have said that a diagonal eyepiece may be constructed with a reflector *before* the eyepiece. In this case, the speculum is sometimes made to slide before the eye at the requisite angle of declination, in which application each eyepiece must necessarily have a groove to receive it, and the eye must be applied without a hole to direct it, but it may be put on and taken off without disturbing the adjustment for distinct vision, and is very simple in its application. But, on the whole, the form represented in fig. 78 is the most convenient, and should generally be preferred, as any common astronomical eyepiece can be applied to it. I have used a diagonal eyepiece of this kind with good effect, when a power of 180 has been applied to the sun and other celestial objects.

Instead of a metallic speculum, a *rectangular prism of glass* is sometimes substituted; for the rays of light are then bent by reflection from the second polished surface, which ought to be *dry*, and undergo two refractions, which achromatize them; and the same effect is thus produced as by polished metal. Ramsden sometimes gave one of the polished faces of a right-angle prism a curve, which prism served instead of a lens in an eyepiece, and also performed the office of a reflector. A semi-globe, or what has been called a bull's eye, has also been used as a diagonal eyepiece, and when the curve is well formed, and the glass good, it is achromatic, and is said to perform pretty well, but it is not superior to the forms already described.

## SECTION II.

## TERRESTRIAL EYEPIECES.

WHEN describing the common refracting telescope (p. 67), I have noticed that three eyeglasses,

placed at double their focal distances from each other, formerly constituted the terrestrial eyepiece, as represented in fig. 47. But this construction, especially for achromatic instruments, has now become obsolete, and is never used except in small pocket spy-glasses formed with a single object-lens. In its place a four-glassed eyepiece has been substituted, which is now universally used in all good telescopes, and which, beside improving the vision and producing an erect position of the images of objects, presents a considerably larger field of view. During the progressive stages of improvement made in the construction of erect eyepieces by Dollond and Ramsden, three, four, and five lenses were successively introduced; and hence, in some of the old telescopes constructed by these artists, we frequently find five lenses of different descriptions composing the eyepiece. But four lenses, arranged in the manner I am now about to describe, have ultimately obtained the preference. In a telescope having a celestial eyepiece of the Huygenian form, the image that is formed in the focus of the object-glass is that which is seen magnified, and in an inverted position; but when a four-glassed eyepiece is used, which produces an erect view of the object, the image is repeated, and the second image, which is formed by the inner pair of lenses, *A B*, on an enlarged scale, is that which the pair of lenses, *C D*, at the eye-end render visible on a scale still more enlarged. The modern terrestrial eyepiece, represented in fig. 79, is,

Fig 79.



in fact, nothing else than a compound microscope, consisting of an object-lens, an amplifying-lens, and an eyepiece composed of a pair of lenses on the principle of the Huygenian eyepiece. Its properties will be best understood by considering the first image of an object, which is formed in the focus of the object-glass, as a small luminous object to be rendered visible, in a magnified state, by a compound microscope. The object to be magnified may be considered as placed near the point *A*, and the magnified image at *i*, which is viewed by the lens *D*. Hence, if we look through such an eyepiece at a small object placed very near the lens *A*, we shall find that it acts as a compound microscope of a moderate magnifying power, increasing, in some cases, the diameter of the object about 10 times, and 100 times in surface.

In order to distinguish the different lenses in this eyepiece, we may call the lens *A*, which is next to the first image, the *object-lens*; the next to *B*, the *amplifying-lens*; the third, or *C*, the *field lens*; and the one next the eye, *D*, the *eyelens*. The first image, formed a little before *A*, may be denominated the *radiant*, or the object from which the rays proceed. Now it is well known as a principle in optics, that if the radiant be brought nearer to the lens than its principal focus, the converging rays will *diverge*, and, on the contrary, if the radiant be put further from the lens than its principal focal distance, the emerging rays will *converge* to a point at a distance beyond the lens, which will depend on the distance of the radiant from the face of the lens. In this place an image of the radiant will be formed by the concurrence of the converging rays, but in a

contrary position; and the length of the image will exceed the length of the radiant in the same proportion, as the distance of the image from the radiant exceeds that of the radiant from the lens. This secondary image of the radiant at *i*, is not well-defined when only one lens, as *A*, is used, owing to the great spherical aberrations, and therefore the amplifying lens is placed at the distance of the shorter conjugate focus, with an intervening diaphragm of a small diameter at the place of the principal focus; the uses of which lens and diaphragm are, first, to cut off the colored rays that are occasioned by the dispersive property of the object-lens, and, secondly, to bring the rays to a shorter conjugate focus for the place of the image than would have taken place with a single lens having only one refractor. As the secondary image is in this way much better defined and free from coloration, the addition of this second lens is a great improvement to vision. For this reason, I am clearly of opinion that the object-glass of a compound microscope, instead of consisting of a small single lens, should be formed of two lenses, on the principle now stated, which would unquestionably add to the distinctness of vision.

With respect to the *proportions of the focal lengths of the lenses* in this four glass eyepiece, Mr. Coddington states, that if the focal lengths, reckoning from *A* to *D*, fig. 79, be as the numbers 3, 4, 4, and 3, and the distances between them on the same scale, 4, 6, and 5, 2, the radii, reckoning from the outer surface of *A*, should be thus:

<i>A</i>	{ First surface	27	nearly plano-convex.
	{ Second surface	1	
<i>B</i>	{ First surface	9	a meniscus.
	{ Second surface	4	
<i>C</i>	{ First surface	1	nearly plano-convex.
	{ Second surface	21	
<i>D</i>	{ First surface	1	double convex.
	{ Second surface	24	

Sir D. Brewster states that a good achromatic eyepiece may be made of four lenses, if their focal lengths, reckoning from that next the object, be as the numbers 14, 21, 27, 32; their distances, 23, 44, 40; their apertures, 5.6, 3.4, 2.6; and the aperture of the diaphragm placed in the interior focus of the fourth eyeglass, 7. Another proportion may be stated: Suppose the lens next the object, *A*, to be 17 $\frac{1}{2}$ ths of an inch focal length, then *B* may be 21 $\frac{1}{2}$  inches; *C*, 2 inches; and *D*, 1 $\frac{1}{2}$ ; and their distances, *A B*, 21 $\frac{1}{2}$ ; *B C*, 35 $\frac{1}{2}$ ths; and *C D*, 23 $\frac{1}{2}$ ths. In one of Ramsden's small telescopes, whose object-glass was 2 $\frac{1}{2}$  inches in focal length, and its magnifying power 15.4, the focal lengths of the eyeglasses were, *A*, 0.775 of an inch; *B*, 1.025; *C*, 1.01; *D*, 0.79; the distances, *A B*, 1.18; *B C*, 1.83; and *C D*, 1.105. In the excellent achromatic telescope of Dollond's construction which belonged to the Duc de Chaulnes, the focal lengths of the eyeglasses, beginning with that next the object, were 11 $\frac{1}{4}$  lines, 19, 22 $\frac{1}{3}$ , 14; their distances, 22.48 lines, 46.17, 21.45; and their thickness at the center, 1.23 lines, 1.25, 1.47. The fourth lens was plano-convex, with the plane side to the eye, and the rest were double convex lenses. This telescope was in focal length three feet five and a half inches.

The magnifying power of this eyepiece, as usually made, differs only in a small degree from what would be produced by using the first or the fourth glass alone, in which case the magnifying power would be somewhat greater, but the vision less distinct; and were the lens next the eye used

alone without the field-glass, the field of view would be much contracted. Stops should be placed between the lenses *A* and *B*, near to *B*, and a larger one between *C* and *D*, to prevent any false light from passing through the lenses to the eye. The more stops that are introduced into a telescope—which should all be blackened—provided they do not hinder the pencils of light proceeding from the object, the better will the instrument perform.

For the information of amateur constructors of telescopes, I shall here state the dimensions of two or three four glassed eyepieces in my possession, which perform with great distinctness, and present a pretty large field of view. In one of these, adapted to a  $4\frac{1}{2}$  inch achromatic, the lens *A*, next the object, is  $1\frac{1}{8}$ ths of an inch focal length and about one inch in diameter, with the plane side next the object. The focal length of the lens *B*, 2 1-10th inches, diameter 7-10ths of an inch, with its plane side next *A*; distance of these lenses from each other, 2 4-10ths inches; distance of the field-lens *C* from the lens *B*,  $5\frac{1}{2}$  inches. The small hole or diaphragm between *A* and *B* is at the focus of *A*, and is about one-sixth of an inch in diameter, and about three-eighths of an inch from the lens *B*. The field-lens *C* is two inches focal length, and  $1\frac{1}{4}$ th of an inch in diameter, with its plane side next the eye. The lens next the eye *D*, is one inch focal distance, half an inch in diameter, and is distant from the field-glass  $1\frac{3}{4}$ ths of an inch, with its plane side next the eye. The magnifying power of this eyepiece is equivalent to that of a single lens whose focal length is half an inch, and with the  $4\frac{1}{2}$  inch object-glass produces a power of about 90 times. The lens next the eye can be changed for another of  $1\frac{3}{8}$ ths of an inch focal length, which produces a power of 65, and the two glasses *C D* can be changed for another set of a longer focal distance, which produces a power of 45 times. The whole length of this eyepiece is  $11\frac{1}{2}$  inches.

In another eyepiece, adapted to a pocket achromatic, whose object-glass is nine inches focal length, the lens *A* is one inch focal length and half an inch in diameter; the lens *B*,  $1\frac{1}{4}$ th of an inch, and half an inch in diameter; their distance,  $1\frac{1}{2}$  inches; the lens *C*, 1 1-10th of an inch focal length and five-eighths of an inch in diameter; the eye-lens *D*, five-eighths of an inch focal length and three-eighths of an inch in diameter; distance between *C* and *D*,  $1\frac{1}{8}$ th of an inch; the distance between *B* and *C*,  $1\frac{3}{4}$ ths of an inch. The whole length of this eyepiece is  $4\frac{1}{2}$  inches, and its power is nearly equal to that of a single lens of half or six-tenths of an inch focal length, the magnifying power of the telescope being about 16 times. Another eyepiece of much larger dimensions has the lens *A* of  $2\frac{1}{2}$  inches focal length and three-fourths of an inch in diameter; the lens *B*,  $2\frac{3}{4}$  inches focus and five-eighths of an inch in diameter, and their distance  $2\frac{3}{4}$ ths inches; the lens *C*,  $2\frac{5}{8}$ ths inches focus and  $1\frac{1}{8}$ th of an inch in diameter; the lens *D*,  $1\frac{1}{4}$ th of an inch focus and three-fourths of an inch in diameter; distance from each other,  $2\frac{3}{4}$ ths inches. The distance between the lenses *B* and *C* is four inches. The magnifying power is equal to that of a single lens  $1\frac{1}{2}$ th of an inch focal distance. When applied to an achromatic object-glass six feet seven inches focal length, it produces a power of about 70 times. This eyepiece has a movable tube nine inches in length, in which the two lenses next the eye are contained, by pulling out which, and consequently increasing the distance between the lenses *B* and *C*, the magnifying

power may be increased to 100, 120, or 140, according to the distance to which this movable tube is drawn out. It has also a second and third set of lenses, corresponding to *C* and *D*, of a shorter focal distance, which produce higher magnifying powers on a principle to be afterwards explained.

#### DESCRIPTION OF AN EYEPIECE, ETC., OF AN OLD DUTCH ACHROMATIC TELESCOPE.

About twenty or thirty years ago, I purchased, in an optician's shop in Edinburgh, a small achromatic telescope, made in Amsterdam, which was supposed by the optician to have been constructed prior to the invention of achromatic telescopes by Mr. Dollond. It is mounted wholly of brass, and in all its parts is a piece of beautiful and exquisite workmanship, and the utmost care seems to have been taken to have all the glasses and diaphragms accurately adjusted. The object-glass is a double achromatic,  $6\frac{1}{2}$  inches focal distance and one inch in diameter, but the clear aperture is only seven-eighths of an inch in diameter. It is perfectly achromatic, and would bear a power of 50 times if it had a sufficient quantity of light. The following inscription is engraved on the tube adjacent to the object-glass: "*Jan van Deyl en Zoon, Invenit et Fecit, Amsterdam, An. 1769.*" Although Dollond exhibited the principle of an achromatic eight or ten years before the date here specified, yet it is not improbable that the artist whose name is here stated may not have heard of Dollond's invention, and that he was really, as he assumes, one of the inventors of the achromatic telescope; for the invention of this telescope by Dollond was not very generally known, except among philosophers and the London opticians, until a number of years after the date above stated. Euler, in his "Letters to a German Princess," in which telescopes are particularly described, makes no mention of, nor the least allusion to, the invention of Dollond, though this was a subject which particularly engaged his attention. Now these letters were written in 1762, but were not published until 1770. When alluding to the defects in telescopes arising from the different refrangibility of the rays of light, in Letter 43, and that they might possibly be rectified by means of different transparent substances, he says, "But neither theory nor practice have hitherto been carried to the degree of perfection necessary to the execution of a structure which should remedy these defects." Mr. B. Martin, in his "Gentleman and Lady's Philosophy," published in 1781, alludes to the achromatic telescope, but speaks of it as if it were but very little, if at all, superior to the common refracting telescope; and therefore I think it highly probable that Jan van Deyl was really an inventor of an achromatic telescope before he had any notice of what Dollond and others had done in this way some short time before.

But my principal object in advertising to this telescope is to describe the structure of the eyepiece, which is a very fine one, and which is somewhat different from the achromatic eyepiece above described. It consists of four glasses, two combined next the eye, and two next the object. Each of these combinations forms an astronomical eyepiece nearly similar to the Huygenian. The lens *A*, next the object, fig. 89, is five-eighths of an inch focal distance, and 4-10ths of an inch in diameter; the lens *B*, three-eighths of an inch focus, and one-fifth of an inch in diameter, and the distance between them somewhat

less than five-eighths of an inch; the diameter of the aperture *e* about 1-15th of an inch. This combination forms an excellent astronomical eyepiece, with a large flat field, and its magnifying power is equivalent to that of a single lens five-eighths or six-eighths of an inch focal length. The lens *C* is half an inch focal length, and 4-10ths of an inch in diameter; the lens *D*, a quarter of an inch focus, and about one-fifth of an

Fig. 80.



inch in diameter; their distance about half an inch or a small fraction more. The hole at *D* is about 1-20th or 1-25th of an inch in diameter, and the distance between the lenses *B* and *C* about  $1\frac{1}{2}$  inches. The whole length of the eyepiece is  $3\frac{1}{4}$  inches—exactly the same size as represented in the engraving. Its magnifying power is equal to that of a single lens one-fourth of an inch focal length; and consequently the telescope, though only  $9\frac{1}{2}$  inches long, magnifies twenty-six times with great distinctness, though there is a little deficiency of light when viewing land objects which are not well illuminated.

The glasses of this telescope are all plano-convex, with their convex sides toward the object, except the lens *D*, which is double convex, but flattest on the side next the eye, and they are all very accurately finished. The two lenses *C* and *D* form an astronomical eyepiece nearly similar to that formed by the lenses *A* and *B*. The focus of the telescope is adjusted by a screw, the threads of which are formed upon the outside of a tube into which the eyepiece slides. The eyepiece and apparatus connected with it is screwed into the inside of the main tube when not in use, when the instrument forms a compact brass cylinder six inches long, which is inclosed in a fish skin case, lined with silk velvet, which opens with hinges.

The lenses in the eyepieces formerly described, though stated to be plano-convexes, are, for the most part, *crossed glasses*, that is, ground on tools of a long focus on the one side, and to a short focus on the other. The construction of the eyepiece of the Dutch telescope above described is one which might be adopted with a good effect in most of our achromatic telescopes; and I am persuaded, from the application I have made of it to various telescopes, that it is even superior in distinctness and accuracy, and in the *flatness of field* which it produces to the eyepiece in common use. The two astronomical eyepieces of which it consists, when applied to large achromatic telescopes, perform with great accuracy, and are excellently adapted for celestial observations.

SECTION III.

DESCRIPTION OF THE PANCREATIC EYEPIECE.

From what we have stated when describing the common terrestrial eyepiece now applied to achromatic instruments (p. 98, fig. 79), it appears obvious that any variety of magnifying powers, within certain limits, may be obtained by removing the set of lenses *C D*, fig. 79, nearer to or farther from the tube which contains the lenses *A* and *B*, on the same principle as the magnifying

power of a compound microscope is increased by removing the eyeglasses to a greater distance from the object lens. If, then, the pair of eyelenses *C D* be attached to an inner tube that will draw out and increase their distance from the inner pair of lenses, as the tube *a b c d*, the magnifying power may be indefinitely increased or diminished by pushing in or drawing out the sliding tube, and a scale might be placed on this tube, which, if divided into equal intervals, will be a scale of magnifying powers, by which the power of the telescope will be seen at every division, when the lowest power is once determined.

Sir David Brewster, in his "Treatise on New Philosophical Instruments," Book I, chap. vii, page 59, published in 1813, has adverted to this circumstance in his description of an "Eyepiece Wire Micrometer," and complains of Mr. Ezekiel Walker having in the "Philosophical Magazine" for August, 1811, described such an instrument as an invention of his own. Dr. Kitchener, some years afterward, described what he called a Pancreatic or omipotent eyepiece, and got one made by Dollond, with a few modifications different from that suggested by Brewster and Walker, which were little else than cutting the single tube into several parts, and giving it the appearance of a new invention. In fact, none of these gentlemen had a right to claim it as his peculiar invention, as the principle was known and recognized long before. I had increased the magnifying powers of telescopes on the same principle several years before any of these gentlemen communicated their views on the subject, although I never formally constructed a scale of powers. Mr. B. Martin, who died in 1782, proposed many years before, such a movable interior tube as that alluded to for varying the magnifying power.

In order to give the reader a more specific idea of this contrivance, I shall present him with a figure and description of one of Dr. Kitchener's pancreatic eyepieces, copied from one lately in my possession. The following are the exact dimensions of this instrument, with the focal distances, &c., of the glasses, &c., of which it is composed.

In. Tenths.

Length of the whole eyepiece, consisting of four tubes, when fully drawn out, or the distance from <i>A</i> to <i>B</i> , fig. 81	14	4
Length of the three tubes on which the scale is engraved, from the commencement of the divisions at <i>B</i> to their termination at <i>C</i>	9	15
Each division into tens is equal to	3-	10ths of an inch.
When the three inner tubes are shut up to <i>C</i> , the length of the eyepiece is exactly	5	5
When these tubes are thus shut up, the magnifying power for a $3\frac{1}{2}$ feet achromatic is 100 times, which is the smallest power. When the inner tube is drawn out one-third of an inch, or to the first division, the power is 110, &c.		
Focal distance of the lens next the object	1	0
Breadth of ditto	0	65
The plane side of this glass is next the object.		
Focal distance of the second glass from the object	1	5
This glass is double and equally convex.		
Breadth	0	5
Distance between these two glasses	1	7
Focal distance of the third or field		

	In. Tenth.
lens, which is plane on the side next the eye	1 1
Breadth of ditto . . . . .	0 55
Focal distance of the lens next the eye	0 6
Breadth of ditto . . . . .	0 43
This glass is plane on the side next the eye.	
Distance between the third and fourth glasses . . . . .	1 1

From the figure and description, the reader will be at no loss to perceive how the magnifying power is ascertained by this eyepiece. If the lowest power for a 44 inch telescope be found to be 100 when the three sliding tubes are shut into the larger one, then by drawing out the tube next the eye four divisions, a power of 140 is produced; by drawing out the tube next the eye its whole length, and the second tube to the division marked 220, a power of 220 times is produced; and drawing out all the tubes to their

utmost extent, as represented in the figure, a power of 400 is obtained. These powers are by far too high for such a telescope, as the powers between 300 and 400 can seldom or never be used. Were the scale to begin at 50 and terminate at 200, it would be much better adapted to a 3½ feet telescope. Each alteration of the magnifying power requires a new adjustment of the eyepiece for distinct vision. As the magnifying power is increased, the distance between the eyeglass and the object-glass must be diminished. Dr. Kirch says that "the paneratic eyetube gives a better defined image of a fixed star, and shows double stars decidedly more distinct and perfectly separated, than any other eyetube, and that such tubes will probably enable us to determine the distances of these objects from each other in a more perfect manner than has been possible heretofore." These tubes are made by Dollond, London, and are sold for two guineas each; but I do not think they excel in distinctness those which are occasionally made by Mr. Tulley and other opticians.

Fig. 81.



## CHAPTER VI.

## MISCELLANEOUS REMARKS IN RELATION TO TELESCOPES.

THE following remarks, chiefly in regard to the manner of using telescopes, may perhaps be useful to young observers, who are not much accustomed to the mode of managing these instruments.

1. *Adjustments requisite to be attended to in the use of Telescopes.*—When near objects are viewed with a considerable magnifying power, the eyetube requires to be removed farther from the object-glass than when very distant objects are contemplated. When the telescope is adjusted for an object 6, 8, or 10 miles distant, a very considerable alteration in the adjustment is requisite in order to see distinctly an object at the distance of two or three hundred yards, especially if the instrument is furnished with a high magnifying power. In this last case, the eyetube requires to be drawn out to a considerable distance beyond the focus for parallel rays. I have found that, in a telescope which magnifies 70 times, when adjusted for an object at the distance of two miles, the adjustment requires to be altered fully one inch in order to perceive distinctly an object at the distance of two or three hundred yards; that is, the tube must be drawn, in this case, an inch farther from the object-glass, and pushed in the same extent, when we wish to view an object at the distance of two or three miles. These adjustments are made, in pocket perspectives, by gently sliding the eyetube in or out, by giving it a gentle circular or spiral motion, until the object appears distinct. In using telescopes which are held in the hand, the best plan is to draw all the tubes out to their full length, and then, looking at the object, with the left hand supporting the main tube near the object-glass, and the right supporting the eyetube, gently and gradually push in the eyepiece until distinct vision be obtained. In Grego-

rian reflecting telescopes this adjustment is made by means of a screw connected with the small speculum; and in large achromatics, by means of a rack and pinion connected with the eyetube. When the magnifying power of a telescope is comparatively small, the eyetube requires to be altered only a very little.

There is another adjustment requisite to be attended to in order to adapt the telescope to the eyes of different persons. Those whose eyes are too convex, or who are short-sighted, require the eyetube to be pushed in, and those whose eyes are somewhat flattened, as old people, require the tube to be drawn out. Indeed, there are scarcely two persons whose eyes do not require different adjustments in a slight degree. In some cases I have found that the difference of adjustment for two individuals, in order to produce distinct vision in each, amounted to nearly half an inch. Hence the difficulty of exhibiting the sun, moon, and planets through telescopes, and even terrestrial objects, to a company of persons who are unacquainted with the mode of using or adjusting such instruments, not one-half of whom generally see the object distinctly; for upon the proper adjustment of a telescope to the eye, the accuracy of vision in all cases depends, and no one except the individual actually looking through the instrument can be certain that it is accurately adjusted to his eye; and even the individual himself, from not being accustomed to the view of certain objects, may be uncertain whether or not the adjustment be correct. I have found by experience that when the magnifying powers are high, as 150 or 200, the difference of adjustment required for different eyes is very slight; but when low powers are used, as 20, 30, or 40, the difference

of the requisite adjustments is sometimes very considerable, amounting to a quarter or half an inch.

2. *State of the atmosphere most proper for observing Terrestrial and Celestial Objects.*—The atmosphere which is thrown around the globe, while it is essentially requisite to the physical constitution of our world, and the comfort of its inhabitants, is found in many instances a serious obstruction to the accurate performance of telescopes. Sometimes it is obscured by mists and exhalations; sometimes it is thrown into violent undulations by the heat of the sun and the process of evaporation; and even, in certain cases, where there appears a pure unclouded azure, there is an agitation among its particles, and the substances incorporated with them, which prevents the telescope from producing distinct vision either of terrestrial or celestial objects. For viewing distant terrestrial objects, especially with high powers, the best time is early in the morning, a little after sunrise, and from that period until about nine o'clock, A. M., in summer, and in the evening about two or three hours before sunset. From about ten o'clock, A. M., until four or five in the afternoon, in summer, if the sky be clear and the sun shining, there is generally a considerable undulation in the atmosphere, occasioned by the solar rays and the rapid evaporation, which prevents high powers from being used with distinctness on any telescope, however excellent. The objects, at such times, when powers of 50, 70, or 100 are applied, appear to undulate like the waves of the sea, and, notwithstanding every effort to adjust the telescope, they appear confused and indistinct. Even with very moderate magnifying powers this imperfection is perceptible. In such circumstances, I have sometimes used a power of 200 times on distant land objects with good effect a little before sunset, when, in the forenoon of the same day, I could not have applied a power of 50 with any degree of distinctness. On days when the air is clear and the atmosphere covered with clouds, terrestrial objects may be viewed with considerably high powers. When there has been a long continued drought, the atmosphere is then in a very unfit state for enjoying distinct vision with high magnifying powers, on account of the quantity of vapors with which the atmosphere is then surcharged, and the undulations they produce. But, after copious showers of rain, especially if accompanied with high winds, the air is purified, and distant objects appear with greater brilliancy and distinctness than at any other seasons. In using telescopes, the objects at which we look should, if possible, be nearly in a direction opposite to that of the sun. When they are viewed nearly in the direction of the sun, their shadows are turned toward us, and they consequently appear dim and obscure. By not attending to this circumstance, some persons, in trying telescopes, have pronounced a good instrument to be imperfect, which, had it been tried on objects properly illuminated, would have been found to be excellent. In our variable northerly climate the atmosphere is not so clear and serene for telescopic observations as in Italy, the south of France, and in many of the countries which lie within the tropics. The undulations of the air, owing to the causes alluded to above, constitute one of the principal reasons why a telescope magnifying above a hundred times can seldom be used with any good effect in viewing terrestrial objects, though I have sometimes used a power of nearly 200 with considerable distinctness in the stillness of a summer or autumnal evening, when the rays

of the declining sun strongly illuminated distant objects.

The atmosphere is likewise frequently a great obstruction to the distinct perception of celestial objects. It is scarcely possible for one who has not been accustomed to astronomical observations to form a conception of the very great difference there is in the appearance of some of the heavenly bodies in different states of the atmosphere. There are certain conditions of the atmosphere essentially requisite for making accurate observations with powerful telescopes, and it is but seldom, especially in our climate, that all the favorable circumstances concur. The nights must be very clear and serene—the moon absent—no twilight—no haziness—no violent wind—no sudden change of temperature, as from thaw to frost—and no surcharge of the atmosphere with aqueous vapor. I have frequently found that, on the first and second nights after a thaw, when a strong frost had set in, and when the heavens appeared very brilliant, and the stars vivid and sparkling, the planets, when viewed with high powers, appeared remarkably and finely indistinct; their margins appeared waving and jagged; and the belts of Jupiter, which at other times were remarkably distinct, were so obscured and ill-defined that they could with difficulty be traced. This was probably owing to the quantity of aqueous vapor, and perhaps icy particles, then floating in the air, and to the undulations thereby produced. When a hard frost has continued a considerable time, this impediment to distinct observation is in a great measure removed. But I have never enjoyed more accurate and distinct views of the heavenly bodies than in fresh, serene evenings, when there was no frost and no wind, and only a few fleecy clouds occasionally hovering around. On such evenings, and on such alone, the highest powers may be applied. I have used magnifying powers on such occasions with good effect which could not have been applied, so as to insure distinct vision, more frequently than two or three days in the course of a year.

Sir William Herschel has observed, in reference to this point, "In beautiful nights, when the outside of our telescopes is dropping with moisture, discharged from the atmosphere, there are now and then favorable hours in which it is hardly possible to put a limit to the magnifying powers; but such valuable opportunities are extremely scarce, and with large instruments it will always be lost labor to observe at other times. In order, therefore, to calculate how long a time it must take to sweep the heavens, as far as they are within the reach of my forty feet telescope, charged with a magnifying power of 1000, I have had recourse to my journals to find how many favorable hours we may annually hope for in this climate; and, under all favorable circumstances, it appears that a year which will afford ninety, or, at most, one hundred hours, is to be called very productive." "In the equator, with my twenty feet telescope, I have swept over zones of two degrees with a power of 157, but an allowance of ten minutes in polar distance must be made for lapping the sweeps over one another where they join. As the breadth of the zones may be increased toward the poles, the northern hemisphere may be swept in about 40 zones; to these we must add 19 southern zones; then 59 zones, which, on account of the sweeps lapping over one another about five minutes of time in right ascension, we must reckon of 25 hours each, will give 1475 hours; and allowing 100 hours per year, we find that with the twenty feet telescope the heavens may be

swept in about fourteen years and three-quarters. Now the time of sweeping with different magnifying powers will be as the squares of the powers; and putting  $p$  and  $t$  for the power and time in the twenty feet telescope, and  $P=1000$  for the power in the forty feet instrument, we shall have

$$p^2 : t : : P^2 : \frac{tP^2}{p^2} = 59840. \text{ Then, making the same}$$

allowance for 100 hours per year, it appears that it will require not less than 598 years to look with the forty feet reflector, charged with the above-mentioned power, only one single moment into each point of space; and even then, so much of the southern hemisphere will remain unexplored as will take up 213 years more to examine.\*

From the above remarks of so eminent an observer, the reader will perceive how difficult it is to explore the heavens with minuteness and accuracy, and with how many disappointments, arising from the state of the atmosphere, the astronomer must lay his account, when employed in planetary or sidereal investigation. Beside the circumstances now stated, it ought to be noticed that a star or a planet is only in a situation for a high magnifying power about half the time it is above the horizon. The density of the atmosphere, and the quantity of vapors with which it is charged near the horizon, prevent distinct vision of celestial objects with high powers until they have risen to at least 15 or 20 degrees in altitude, and the highest magnifiers can scarcely be applied with good effect unless the object is near the meridian, and at a considerable elevation above the horizon. If the moon be viewed a little after her rising, and afterward when she comes to her highest elevation in autumn, the difference in her appearance and distinctness will be strikingly perceptible. It is impossible to guess whether a night be well adapted for celestial observations until we actually make the experiment, and instruments are frequently condemned, when tried at improper seasons, when the atmosphere only is in fault. A certain observer remarks, "I have never seen the face of Saturn more distinctly than in a night when the air has been so hazy that with my naked eye I could hardly discern a star of less than the third magnitude. The degree of the transparency of the air is likewise varying almost in the course of every minute, so that even in the course of the same half hour planets and stars will appear perfectly defined, and the reverse. The vapors moving and undulating the atmosphere, even when the sky appears clear to the naked eye, will in a few instants destroy the distinctness of vision, and in a few seconds more the object will resume its clear and well-defined aspect."†

3. *On the magnifying Powers requisite for observing the Phenomena of the different Planets, Comets, Double Stars, &c.*—There are some objects connected with astronomy which cannot be perceived without having recourse to instruments and to powers of great magnitude; but it is a vulgar error to imagine that very large and very expensive telescopes are absolutely necessary for viewing the greater part of the more interesting scenery of the

heavens. Most of the phenomena of the planets, comets, double stars, and other objects, are visible with instruments of moderate dimensions, so that every one who has a relish for celestial investigations may, at a comparatively small expense, procure a telescope for occasional observations which will show the principal objects and phenomena described in books on astronomy. Many persons have been misled by some occasional remarks which Sir W. Herschel made, in reference to certain very high powers which he sometimes put, by way of experiment, on some of his telescopes, as if these were the powers requisite for viewing the objects to which he refers. For example, it is stated that he once put a power of 6150 times on his seven feet Newtonian telescope of 6 3-10ths inches aperture; but this was only for the purpose of an experiment, and could be of no use whatever when applied to the moon, the planets, and most objects in the heavens. Herschel, through the whole course of his writings, mentions his only having used it *twice*, namely, on the stars  $\alpha$  Lyrae and  $\gamma$  Leonis, which stars can be seen more distinctly and sharply defined with a power of 420. To produce a power of 6150 on such a telescope would require a lens of only 1-77th of an inch in focal distance; and it is questioned by some whether Herschel had lenses of so small a size in his possession, or whether it is possible to form them with accuracy.

*Powers requisite for observing the Phenomena of the Planets.*—The planet *Mercury* requires a considerable magnifying power in order to perceive its phases with distinctness. I have seldom viewed this planet with a less power than 100 and 150, with which powers its half-moon, its gibbous, and its crescent phase may be distinctly perceived. With a power of 40, 50, or even 60 times, these phases can with difficulty be seen, especially as it is generally at a low altitude when such observations are made. The phases of *Venus* are much more easily distinguished, especially the *crescent* phase, which is seen to the greatest advantage about a month before and after the inferior conjunction. With a power not exceeding 25 or 30 times, this phase, at such periods, may be easily perceived. It requires, however, much higher powers to perceive distinctly the variations of the gibbous phase; and if this planet be not viewed at a considerably high altitude when in a half-moon or gibbous phase, the obscurity and undulations of the atmosphere near the horizon prevent such phases from being accurately distinguished, even when high powers are applied. Although certain phenomena of the planets may be seen with such low powers as I have now stated, yet in every instance the highest magnifying powers consistent with distinctness should be preferred, as the eye is not then strained, and the object appears with a greater degree of magnitude and splendor. The planet *Mars* requires a considerable degree of magnifying power, even when at its nearest distance from the earth, in order to discern its spots and its gibbous phase. I have never obtained a satisfactory view of the spots which mark the surface, and their relative position, with a less power than 130, 160, or 200 times; and even with such powers, persons not much accustomed to look through telescopes find a difficulty in distinguishing them.

The strongest and most prominent *belts of Jupiter* may be seen with a power of about 45, which power may be put upon a twenty-inch achromatic or a one foot reflector; but a satisfac-

\* Philosophical Transactions for 1800, vol. xc, p. 80, &c.

† In using telescopes within doors, care should generally be taken that there be no fires in the apartment where they are placed for observation, and that the air within be nearly of the same temperature as the air of the surrounding atmosphere; for if the room be filled with heated air, when the windows are opened there will be a current of cold rushing in, and of heated rushing out, which will produce such an undulation and tremulous motion as will prevent any celestial object from being distinctly seen.

tery view of all the belts, and the relative positions they occupy, cannot be obtained with much lower powers than 80, 100, or 140. The most common positions of these belts are, one dark and well-defined belt to the south of Jupiter's equator; another of nearly the same description to the north of it, and one about his north and his south polar circles. These polar belts are much more faint, and, consequently, not so easily distinguished, as the equatorial belts. The moons of this planet, in a very clear night, may sometimes be seen with a pocket one foot achromatic glass magnifying about 15 or 16 times. Some people have pretended that they could see some of these satellites with their naked eye; but this is very doubtful, and it is probable that such persons mistook certain fixed stars which happened to be near Jupiter for his satellites. But, in order to have a clear and interesting view of these, powers of at least 80 or 100 times should be used. In order to perceive their immersions into the shadow of Jupiter, and the exact moment of their emersions from it, a telescope not less than a 4 inch achromatic, with a power of 150, should be employed. When these satellites are viewed through large telescopes with high magnifying powers, they appear with well-defined discs, like small planets. The planet Jupiter has generally been considered as a good test by which to try telescopes for celestial purposes. When it is near the meridian and at a high altitude, if its general surface, its belts, and its margin appear distinct and well-defined, it forms a strong presumptive evidence that the instrument is a good one.

The planet *Saturn* forms one of the most interesting objects for telescopic observation. The ring of Saturn may be seen with a power of 45; but it can only be contemplated with advantage when powers of 100, 150, and 200 are applied to a three or a five feet achromatic. The belts of *Saturn* are not to be seen distinctly with an achromatic of less than 23 $\frac{1}{4}$  inches aperture, or a Gregorian reflector of less than four inches aperture, nor with a less magnifying power than 100 times. Sir W. Herschel has drawn this planet with five belts across its disc; but it is seldom that above one or two of them can be seen by moderate-sized telescopes and common observers. The division of the double ring, when the planet is in a favorable position for observation, and in a high altitude, may sometimes be perceived with a 44 inch achromatic, with an aperture of 23 $\frac{1}{4}$  inches, and with powers of 150 or 180; but higher powers and larger instruments are generally requisite to perceive this phenomenon distinctly; and even when a portion of it is seen at the extremities of the *ansa*, the division cannot, in every case, be traced along the whole of the half-circumference of the ring which is presented to our eye. Mr. Halley's engraving of Saturn, in the "Philosophical Transactions" for 1723, though taken with a Newtonian reflector with a power of 228, represents the division of the ring as seen only on the *ansa* or extremities of the elliptical figure in which the ring appears. The best period for observing this division is when the ring appears at its utmost width. In this position it was seen in 1749, and it will appear nearly in the same position in 1855. When the ring appears like a very narrow ellipse a short time previous to its disappearance, the division, or dark space between the rings, cannot be seen by ordinary instruments.

Sir W. Herschel very properly observes, "There is not, perhaps, another object in the heavens that

presents us with such a variety of extraordinary phenomena as the planet Saturn: a magnificent globe, encompassed by a stupendous double ring; attended by seven satellites; ornamented with equatorial belts; compressed at the poles; turning upon its axis, mutually eclipsing its ring and satellites, and eclipsed by them; the most distant of the rings also turning upon its axis, and the same taking place with the farthest of the satellites; all the parts of the system of Saturn occasionally reflecting light on each other; the rings and moons illuminating the nights of the Saturnian, the globe and satellites enlightening the dark parts of the ring; and the planet and rings throwing back the sun's beams upon the moons, when they are deprived of them at the time of their conjunctions." This illustrious astronomer states that with a new seven feet mirror of extraordinary distinctness he examined this planet, and found that the ring reflects more light than the body, and with a power of 570 the color of the body becomes yellowish, while that of the ring remains more white. On March 11, 1780, he tried the powers of 222, 332, and 440 successively, and found the light of Saturn less intense than that of the ring; the color of the body turning, with the high powers, to a kind of yellow white, while that of the ring still remained white.

Most of the satellites of Saturn are difficult to be perceived with ordinary telescopes, excepting the fourth, which may be seen with powers of from 60 to 100 times. It was discovered by Huygens in 1655 by means of a common refracting telescope 12 feet long, which might magnify about 70 times. The next in brightness to this is the fifth satellite, which Cassini discovered in 1671 by means of a 17 feet refractor, which might carry a power of above 80 times. The third was discovered by the same astronomer in 1672 by a longer telescope; and the first and second in 1684, by means of two excellent object-glasses of 100 and 136 feet, which might have magnified from 200 to 230 times. They were afterward seen by two other glasses of 70 and 90 feet, made by Campani, and sent from Rome to the Royal Observatory at Paris by the king's order, after the discovery of the third and fifth satellites. It is asserted, however, that all those five satellites were afterward seen with a telescope of 34 feet, with an aperture of 3-10ths inches, which would magnify about 120 times. These satellites, on the whole, except the fourth and fifth, are not easily detected. Dr. Derham, who frequently viewed Saturn through Huygens' glass of 126 feet focal length, declares, in the preface to his "Astro-Theology," that he could never perceive above three of the satellites. Sir W. Herschel observes, that the visibility of these minute and extremely faint objects depends more on the penetrating than upon the magnifying power of our telescopes; and that with a ten feet Newtonian, charged with a magnifying power of only 60, he saw all the five old satellites; but the sixth and seventh, which were discovered and were easily seen with his forty feet telescope, and were also visible in his twenty feet instrument, were not discernible in the seven or the ten feet telescopes, though all that magnifying power can do may be done as well with the seven feet as with any larger instrument. Speaking of the seventh satellite, he says, "Even in my forty feet reflector it appears no bigger than a very small lucid point. I see it, however, very well in the twenty feet reflector, to which the exquisite figure of the speculum not a little contributes." A late observer asserts that in 1825, with a twelve feet achromatic,



of seven inches aperture, made by Tully, with a power of 150, the seven satellites were easily visible, but not so easily with a power of 240; and that the planet appeared as bright as brilliantly burnished silver, and the division in the ring and a belt were very plainly distinguished with a power of 240.

The planet *Uranus*, being generally invisible to the naked eye, is seldom an object of attention to common observers. A considerable magnifying power is requisite to make it appear in a planetary form with a well-defined disc. The best periods for detecting it are when it is near its opposition to the sun, or when it happens to approximate to any of the other planets, or to a well known fixed star. When none of these circumstances occur, its position requires to be pointed out by an equatorial telescope. On the morning of the 25th of January, 1781, this planet happened to be in conjunction with Venus, at which time it was only four minutes north of that planet. Several days before this conjunction I made observations on Uranus. On the evening of the 24th, about eight hours before the conjunction, the two planets appeared in the same field of the telescope, the one exceedingly splendid, and the other more obscure, but distinct and well-defined. Uranus could not be perceived either with the naked eye or with an opera-glass, but could be distinguished as a very small star by means of a pocket achromatic telescope magnifying about 14 times. It is questionable whether, under the most favorable circumstances, this planet can ever be distinguished by the naked eye. With magnifying powers of 50 and 70, it appeared as a moderately large star with a steady light, but without any sensible disc. With powers of 120, 180, and 250, it presented a round and pretty well-defined disc, but not so luminous and distinct as it would have done in a higher altitude.

The *Double Stars* require a great variety of powers in order to distinguish the small stars that accompany the larger. Some of them are distinguished with moderate powers, while others require pretty large instruments, furnished with high magnifying eyepieces. I shall therefore select only a few as a specimen. The star *Castor*, or  $\alpha$  Geminorum, may be easily seen to be double with powers of from 70 to 100. I have sometimes seen these stars, which are nearly equal in size and color, with a terrestrial power of 44 on a 44 inch achromatic. The appearance of this star with such powers is somewhat similar to that of  $\alpha$  Coronæ in a seven feet achromatic of five inches aperture, with a power of 500.  $\gamma$  Andromedæ may be seen with a moderate power. In a thirty inch achromatic of two inches aperture and a power of 80, it appears like  $\epsilon$  Bootis when seen in a five feet achromatic with a power of 460. This star is said to be visible even in a one foot achromatic with a power of 35.  $\epsilon$  Lyræ, which is a quintuple star, but appears to the naked eye as a single star, may be seen to be double with a power of from six to twelve times.  $\gamma$  Leonis is visible in a 44 inch achromatic with a power of 180 or 200. *Rigel*, in a 3½ feet achromatic, may be seen with powers varying from 130 to 200. The small star, however, which accompanies Rigel, is sometimes difficult to be perceived, even with such powers.  $\epsilon$  Bootis is seldom distinctly defined with an achromatic of less aperture than 3¼ inches, or a reflector of less than five inches, with a power of at least 250.

These and similar stars are not to be expected to be seen equally well at all times, even when the magnifying and illuminating powers are pro-

perly proportioned, as much depends upon the state of the weather, and the pureness of the atmosphere. In order to perceive the greatest of the double stars, Sir W. Herschel recommends that the power of the telescope should be adjusted upon a star known to be single, at nearly the same altitude, magnitude, and color with the double star which is to be observed, or upon one star above and another below it. Thus the late Mr. Albert, the astronomer, could not see the two stars of  $\gamma$  Leonis when the focus was adjusted upon that star itself, but he soon observed the small star after he had adjusted the focus upon Regulus. An exact adjustment of the focus of the instrument is indispensably requisite in order to perceive such minute objects.

In viewing the *Nebulæ*, and the very small and immensely distant fixed stars, which require much light to render them visible, a large aperture of the object-glass or speculum, which admits of a great quantity of light, is of more importance than high magnifying powers. It is right, indeed, accompanied with a moderate magnifying power, that enables us to penetrate into the distant regions of space. Sir W. Herschel, when sweeping the profundities of the Milky Way, and the Hand and Club of Orion, used a telescope of the Newtonian form, 20 feet focal length and 13 7-10ths inches in diameter, with a power of only 157. On applying this telescope and power to a part of the *Via Lactea*, he found that it completely resolved the whole whitish appearance into stars, which his former telescopes had not light enough to effect, and which smaller instruments with much higher magnifying powers would not have effected. He tells us that, with this power, "the glorious multitude of stars," in the vicinity of Orion, "of all possible sizes, that presented themselves to view, was truly astonishing, and that he had fields which contained 70, 90, and 110 stars, so that a belt of fifteen degrees long and two degrees broad, which passed through the field of the telescope in an hour, could not contain less than fifty thousand stars that were large enough to be distinctly numbered." In viewing the Milky Way, the Nebulæ, and small clusters of stars, such as *Præsepe* in Cancer, I generally use a power of 55 times on an achromatic telescope six feet six inches in focal length and four inches in diameter. The eyepiece which produces this power—which I formed for the purpose—consists of two convex lenses, the one next the eye three inches focal length and 1 2-10ths of an inch diameter, and that next the object 3½ inches focus and 1 4-10ths of an inch diameter, the deepest convex surfaces being next each other, and their distance a quarter of an inch. With this eyepiece a very large and brilliant field of view is obtained; and I find it preferable to any higher powers in viewing the nebulosities and clusters of stars. In certain spaces of the heavens it sometimes presents in one field nearly a hundred stars. It likewise serves to exhibit a very clear and interesting view of the full moon.

In observing *Comets*, a very small power should generally be used, even on large instruments. These bodies possess so small a quantity of light, and they are so frequently enveloped in a veil of dense atmosphere, that magnifying power sometimes renders them more obscure, and therefore the illuminating power of a large telescope with a small power is in all cases to be preferred. A comet eyepiece should be constructed with a very large and uniformly distinct field, and should magnify only from 15 to 30 or 40 times, and the lenses of such an eyetube should be nearly two

inches in diameter. The late Rev. F. Wollaston recommended, for observing comets, "a telescope with an achromatic object-glass of 16 inches focal length and two inches aperture, with a Rumsted's eye-glass magnifying about 25 times, mounted on a very firm equatorial stand, the field of view taking in two degrees of a great circle."

In viewing the *moon*, various powers may be applied, according to circumstances. The best periods of the moon for inspecting the inequalities on its surface are either when it assumes a crescent or a half-moon phase, or two or three days after full moon, and particularly about the third quarter, when the orb is waning, and when the shadows of its mountains and vales are thrown in a different direction from what they are when on the increase, the most prominent and interesting views may be obtained. The most convenient season for obtaining such views is during the autumnal months, when the moon, about the third quarter, sometimes rises as early as eight o'clock, P. M., and may be viewed at a considerably high altitude by ten or eleven. When in the positions now alluded to, and at a high altitude, very high magnifying powers may sometimes be applied with good effect, especially if the atmosphere be clear and serene. I have sometimes applied a power, in such cases, of 350 times on a 46 inch achromatic with considerable distinctness; but it is only two or three times in a year, and when the atmosphere is remarkably favorable, that such a power can be used. The autumnal evenings are generally best fitted for such observations. The *full moon* is an object which is never seen to advantage with high powers, as no shadows or inequalities on its surface can then be perceived. It forms, however, a very beautiful object when magnifying powers not higher than 40, 50, or 60 times are used. A power of 45 times, if properly constructed, will show the *whole of the moon* with a margin around it, when the darker and brighter parts of its surface will present a variegated aspect, and appear somewhat like a map to the eye of the observer.

4. *Mode of exhibiting the Solar Spots.*—The solar spots may be contemplated with advantage by magnifying powers varying from 60 to 180 times; about 90 times is a good medium power, though they may sometimes be distinguished with very low powers, such as those usually adapted to a one foot telescope, or even by means of a common opera glass. The common astronomical eyepieces given along with achromatic telescopes, and the sunglasses connected with them, are generally ill adapted for taking a pleasant and comprehensive view of the solar spots. In the high magnifying powers, the first eyeglass is generally at too great a distance from the eye, and the sunglass which is screwed over it removes it to a still greater distance from the point to which the eye is applied, so that not above one-third of the field of view can be taken in. This circumstance renders it difficult to point the instrument to any particular small spot on the solar disc which we wish minutely to inspect; and beside, it prevents us from taking a comprehensive view of the *relative positions* of all the spots that may at any time be traversing the disc. To obviate this inconvenience, the sunglass would require to be placed so near to the glass next the eye as almost to touch it. But this is sometimes difficult to be attained, and in high powers even the thickness of the sunglass itself is sufficient to prevent the eye from taking in the whole field of view. For preventing the inconveniences to

which I now allude, I generally make use of a *terrestrial eyepiece* of a considerable power, with a large field; the sunglass is fixed at the end of a short tube, which slides on the eyepiece, and permits the colored glass to approach within a line or two of the lens next the eye, so that the whole field of the telescope is completely cleared. The eyepiece allowed to carry a magnifying power of 95 times for a 46 inch telescope, and takes in about three-fourths of the surface of the sun, so that the relative positions of all the spots may generally be perceived at one view. Such a power is, in most cases, quite sufficient for ordinary observations, and I have seldom found any good effect to arise from attempting very high powers when minutely examining the solar spots.

But the most pleasant mode of viewing the solar spots, especially when we wish to exhibit them to others, is to throw the image of the sun upon a white screen, placed in a room which is considerably darkened. It is difficult, however, when the sun is at a high altitude, to put this method into practice, on account of the great obliquity with which his rays then fall, which prevents a screen from being placed at any considerable distance from the eye-end of the telescope. The following plan, therefore, is that which I uniformly adopt, as being both the easiest and the most satisfactory. A telescope is placed in a convenient position, so as to be directed to the sun. This telescope is furnished with a *diagonal eyepiece*, such as that represented in fig. 77 (p. 97). The window-shutters of the apartment are all closed excepting a space sufficient to admit the solar rays; and when the telescope is properly adjusted, a beautiful image of the sun, with all the spots which then happen to diversify his surface, is thrown upon the *ceiling* of the room. This image may be from 12 to 20, or 50 inches or more in diameter, according to the distance of the ceiling from the diagonal eyepiece. The greater this distance is, the larger the image. If the sun is at a very high altitude, the image will be elliptical; if he be at no great distance from the horizon, the image will appear circular, or nearly so; but in either case the spots will be distinctly depicted, provided the focus of the telescope be accurately adjusted. In this exhibition, the apparent motion of the sun produced by the rotation of the earth, and the passage of thin fleeces of clouds across the solar disc, exhibit a very pleasing appearance.

By this mode of viewing the solar spots we may easily ascertain their diameter and magnitude, at least to a near approximation. We have only to take a scale of inches, and measure the diameter of any well-defined and remarkable spot, and then the diameter of the solar image; and, comparing the one with the other, we can ascertain the number of miles, either lined or square, comprehended in the dimensions of the spot. For example, suppose a spot to measure half an inch in diameter, and the whole image of the sun 25 inches, the proportion between the diameter of the spot and that of the sun will be as 1 to 50; in other words, the *one-fiftieth* part of the sun's diameter. Now this diameter being 880,000 miles, this number, divided by 50, produces a quotient of 17,600—the number of miles which its diameter measures. Such a spot will therefore contain an area of 243,285,504, or more than two hundred and forty-three millions of square miles, which is 46 millions of miles more than the whole superficies of the terraqueous globe. Again, suppose the diameter of a spot measures 3-10ths of

an inch, and the solar image 23 inches, the proportion of the diameter of the spot to that of the sun is as 3 to 230—the number of tenths in 23 inches. The number of miles in the spot's diameter will therefore be found by the following proportion: 230 : 880,000 :: 3 : 11,478; that is, the diameter of such a spot measures eleven thousand four hundred and seventy-eight miles. Spots of such sizes are not unfrequently seen to transit the solar disc.

By this mode of viewing the image of the sun, his spots may be exhibited to twenty or thirty individuals at once without the least straining or injury to the eyes; and as no separate screen is requisite, and as the ceilings of rooms are generally white, the experiment may be performed in half a minute without any previous preparation except screwing on and adjusting the eyepiece. The manner of exhibiting the solar spots in this way is represented in fig. 82.

##### 5. On the Space-penetrating Power of Telescopes.

—The power of telescopes to penetrate into the profundity of space is the result of the quantity of light they collect and send to the eye in a state fit for vision. This property of telescopes is sometimes designated by the expression *Illuminating Power*.

Sir W. Herschel appears to have been the first who made a distinction between the *magnifying power* and the *space-penetrating power* of a telescope; and there are many examples which prove that such a distinction ought to be made, especially in the case of large instruments. For example, the small star, or speck of light which accompanies the pole-star, may be seen through a telescope of large aperture with a smaller magnifying power than with a telescope of a small aperture furnished with a much higher power. If the magnifying power is sufficient to show the small star completely separated from the rays which surround the large one, this is sufficient, in one point of view; but, in order that this effect may be produced, so as to render the small star perfectly distinguishable, a certain quantity of light must be admitted into the pupil of the eye, which quantity depends upon the area of the object-glass or speculum of the instrument, or, in other words, on the illuminating power. If we compare a telescope of 23½ inches aperture with one of five inches aperture, when the magnifying power of each does not exceed 50 times for terrestrial objects, the effect of illuminating power is not so evident; but if we use a power of 100 for day objects, and 180 for the heavenly bodies, the effects of illuminating power is so clearly perceptible, that objects not only appear brighter and more clearly visible in the larger telescope, but with the same magnifying power they also appear larger, particularly when the satellites of Jupiter and small stars are the objects we are viewing.

Sir W. Herschel remarks, that "objects are viewed in their greatest perfection when, in penetrating space, the magnifying power is so low as only to be sufficient to show the object well, and when, in magnifying objects, by way of examining them minutely, the space-penetrating power is no higher than what will suffice for the purpose; for in the use of either power, the injudicious overcharge of the other will prove hurtful to vision." When illuminating power is in too high a degree, the eye is offended by the extreme brightness of the object; when it is in too low a degree, the eye is distressed by its endeavors to see what is beyond its reach; and therefore it is desirable, when we wish to give the eye all the assistance possible, to have the illuminating and

the magnifying powers in due proportion. What this proportion is, depends, in a certain degree, upon the brightness of the object. In proportion to its brightness or luminosity, the magnifying power may, to a certain extent, be increased. Sir W. Herschel remarks in reference to  $\alpha$  Lyra, "This star, I surmise, has light enough to bear being magnified at least a hundred thousand times, with no more than six inches of aperture." However beautifully perfect any telescopes may appear, and however sharp their *defining power*, their per-

Fig. 82.

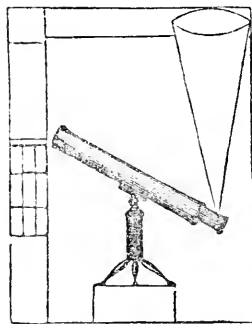

formance is limited by their illuminating powers, which are as the squares of the diameters of the apertures of the respective instruments. Thus a telescope whose object-glass is four inches diameter will have four times times the quantity of light, or illuminating power, possessed by a telescope whose aperture is only two inches, or in the proportion of 16 to 4; the square of 4 being 16, and the square of 2 being 4.

The nature of the *space-penetrating power* to which we are adverting, and the distinction between it and magnifying power, may be illustrated from a few examples taken from Sir W. Herschel's observations.

The first observation which I shall notice refers to the *nebula* between  $\nu$  and  $\zeta$  Ophiuchi, discovered by Messier in 1764. The observation was made with a ten feet reflector, having a magnifying power of 250, and a space-penetrating power of 23.67. His note is dated May 3, 1783. "I see several stars in it, and make no doubt a higher power and more light will resolve it all into stars. This seems to me a good nebula for the purpose of establishing the connection between nebulae and clusters of stars in general." "June 18, 1784. The same nebula viewed with a Newtonian twenty feet reflector; penetrating power 61, and a magnifying power of 157; a very large and a very bright cluster of excessively compressed stars. The stars are but just visible, and are of unequal magnitudes. The large stars are red; the cluster is a miniature of that near Flamsteed's forty-second Comae Berenices. Right ascension, 17h. 6m. 32s. Polar distance,  $108^{\circ} 18''$ ." In this case, a penetrating power of about 23, with a magnifying power of 250, barely showed a few stars; while in the second instrument the illuminating power of 60, with the magnifying power of only 157, showed them completely.

Subsequently to the date of the latter observation, the twenty feet Newtonian telescope was converted into an Herschelian instrument by taking away the small speculum, and giving the large one the proper inclination for obtaining the front view; by which alteration the illuminating power was increased from 61 to 75, and the advantage

derived from the alteration was evident in the discovery of the satellites of Uranus by the altered telescope, which before was incompetent in the point of penetration, or illuminating power. "March 14, 1798, I viewed the Georgian planet (or Uranus) with a new twenty-five feet reflector. Its penetrating power is 95.85, and having just before also viewed it with my twenty feet instrument, I found that with an equal magnifying power of 300, the twenty-five feet telescope had considerably the advantage of the former." The aperture of the twenty feet instrument was 18.3 inches, and that of the twenty-five feet telescope 24 inches, so that the superior effect of the latter instrument must have been owing to its greater illuminating power. The following observations show the superior power of the forty feet telescope, as compared with the twenty feet. "Feb. 24, 1786, I viewed the nebula near Flamsteed's fifth Serpents with my twenty feet reflector, magnifying power 157. The most beautiful, extremely compressed cluster of small stars, the greatest part of them gathered together into one brilliant nucleus, evidently consisting of stars, surrounded with many detached gathering stars of the same size and color. R. A., 15h. 7m. 12s. P. D.  $87^{\circ} 8''$ ." "May 27, 1791, I viewed the same object with my forty feet telescope, penetrating power 191.69, magnifying power 370. A beautiful cluster of stars. I counted about 200 of them. The middle of it is so compressed that it is impossible to distinguish the stars." "Nov. 5, 1791, I viewed Saturn with the twenty and forty feet telescopes. *Twenty feet.*—The fifth satellite of Saturn is very small. The first, second, third, fourth and fifth, and the new sixth satellites are in their calculated places. *Forty feet.*—I see the new sixth satellite much better than with the twenty feet. The fifth is also much larger here than in the twenty feet, in which it was nearly the same size as a small fixed star, but here it is considerably larger than that star."

These examples, and many others of a similar kind, explain sufficiently the nature and extent of that species of power that one telescope possesses over another, in consequence of its enlarged aperture; but the exact quantity of this power is in some degree uncertain. To ascertain practically the illuminating power of telescopes, we must try them with equal powers on such objects as the following: the small stars near the pole-star, and near Rigel and  $\alpha$  Bootis; the division in the ring of Saturn; and distant objects in the twilight or toward the evening. These objects are distinctly seen with a five feet achromatic of 3 8-10ths inches aperture, and an illuminating power of 144, while they are scarcely visible in a 3 1/2 feet with an aperture of 2 3/4ths inches, and an illuminating power of 72, supposing the same magnifying power to be applied. The illuminating power of a telescope is best estimated, in regard to land objects, when it is tried on minute objects, and such as are badly lighted up; and the advantage of a telescope with a large aperture will be most obvious when it is compared with another of inferior size in the close of the evening, when looking at a printed bill composed of letters of various sizes. As darkness comes on, the use of illuminating power becomes more evident. In a five feet telescope some small letters will be legible which are hardly discernible in the 3 1/2 feet, and in the 2 1/2 feet are quite undefinable, though the magnifying powers be equal. Sir W. Herschel informs us that, in the year 1776, when he had erected a telescope of twenty feet focal length of the Newtonian construction, one of its effects by trial was, that when, toward evening, on account of darkness,

the natural eye could not penetrate far into space, the telescope possessed that power sufficiently to show, by the dial of a distant church steeple, what o'clock it was, notwithstanding the naked eye could no longer see the steeple itself.

In order to convey an idea of the numbers by which the degree of space-penetrating power is expressed, and the general grounds on which they rest, the following statements may be made. The depth to which the naked eye can penetrate into the spaces of the heavens is considered as extending to the twelfth order of distances; in other words, it can perceive a star at a distance twelve times farther than those luminaries, such as Sirius, Arcturus, or Capella, which, from their vivid light, we presume to be nearest to us. It has been stated above that Herschel calculated his ten feet telescope to have a space-penetrating power of 25.67, that is, it could enable us to descry a star 25 times farther distant than the naked eye can reach. His twenty feet Newtonian was considered as having a similar power of 61; his 25 feet, nearly 96; and his forty feet instrument, a power of 191.69. If each of these numbers be multiplied by 12, the product will indicate how much farther these telescopes will penetrate into space than the nearest range of the fixed stars, such as those of the first magnitude. For instance, the penetrating power of the forty feet reflector being 191.69, this number, multiplied by 12, gives a product of 2300, which shows that, were there a series of two thousand three hundred stars extended in a line beyond Sirius, Capella, and similar stars, each star separated from the one beyond it by a space equal to the distance of Sirius from the earth, they might be all seen through the forty-feet telescope. In short, the penetrating power of telescopes is a circumstance which requires to be particularly attended to in our observations of celestial phenomena, and in many cases is of more importance than *magnifying* power. It is the effect produced by illuminating power that renders telescopes, furnished with comparatively small magnifying powers, much more efficient in observing comets, and certain nebulae and clusters of stars, than when high powers are attempted. Every telescope may be so adjusted as to produce different space-penetrating powers. If we wish to diminish such a power, we have only to contract the object-glass or speculum by placing circular rims, or apertures of different degrees of breadth, across the mouth of the great tube of the instrument. But we cannot increase this illuminating power beyond a certain extent, which is limited by the diameter of the object-glass. When we wish illuminating power beyond this limit, we must be furnished with an object-glass or speculum of a larger size; and hence the rapid advance in price of instruments which have large apertures, and consequently high illuminating powers. Mr. Tully's 3 1/2 feet achromatics of 2 3/4ths inches aperture sell at £26 5s.; when the aperture is 3 1/4ths inches, the price is £12; when 3 3/4ths inches, £68 5s. The following table contains a statement of the "comparative lengths, apertures, illuminating powers, and prices of achromatic refractors and Gregorian reflectors," according to Dr. Kitchener:

The illuminating powers stated in the following table are only comparative. Fixing on the number 25 as the illuminating power of a two feet telescope, 1 6-10ths of an inch aperture, that of a 2 1/2 feet, two inches aperture, will be 40; of a five feet, 3 8-10ths inches aperture, 144, &c. If the illuminating power of a Gregorian 1 1/2 foot, and three inches aperture, be 90, a five feet, with nine inches aperture, will be 810, &c.

ACHROMATIC REFRACTORS.				GREGORIAN, ETC., REFLECTORS.					
Length and name they are known by.	Diameter of aperture.		Illuminating power.	Price.	Length and name they are known by.	Diameter of aperture.		Illuminating power.	Price.
Feet.	In.	Th.		L. s.	Feet.	In.	Th.		L. s.
2	1.	6	25	4 4	1	2.	5	62	7 7
2½	2		40	12 12	1½	3		90	12 12
3½	2.	7	72	21 to	2	4.	5	202	20
				42	3	5.	5	302	50
5	3.	8	144	105 to	4	7		490	105
				150	7 Newtonian	7		490	126
7	5		250	250	5 Gregorian	9		810	200
7	6		369	360	19 Newtonian	10		1000	315

6. *On choosing Telescopes, and ascertaining their Properties.*—It is an object of considerable importance to every astronomical observer that he should be enabled to form a judgment of the qualities of his telescope, and of any instruments of this description which he may intend to purchase. The following directions may perhaps be useful to the reader in directing him in the choice of an achromatic refracting telescope :

Supposing that an achromatic telescope of 3½ feet focal length and 3¼th inches aperture were offered for sale, and that it were required to ascertain whether the object-glass, on which its excellence chiefly depends, is a good one, and duly adjusted, some opinion may be formed by laying the tube of the telescope in a horizontal position, on a firm support, about the height of the eye, and by placing a printed card or a watch-glass vertically, but in an inverted position, against some wall or pillar at 40 or 50 yards distant, so as to be exposed to a clear sky. When the telescope is directed to this object, and accurately adjusted to the eye, should the letters on the card, or the strokes and dots on the watch glass, appear clearly and sharply defined, without any mistiness or coloration, and if very small spots appear well-defined, great hopes may be entertained that the glass will turn out a good one. But a telescope may appear a good one, when viewing common terrestrial objects, to eyes unaccustomed to discriminate deviations from perfect vision, while it may turn out to be an indifferent one when directed to certain celestial objects. Instead, therefore, of a printed card, fix a black board, or one-half of a sheet of black paper, in a vertical position at the same distance, and a circular disc of white writing paper, about one-fourth of an inch in diameter, on the center of the black ground; then, having directed the telescope to this object, and adjusted for the place of distinct vision, mark with a black-lead pencil the sliding eyetube at the end of the main tube, so that this position can always be known; and if this sliding tube be gradually drawn out or pushed in while the eye beholds the disc, it will gradually enlarge and lose its color until its edges cease to be well-defined. Now if the enlarged misty circle is observed to be concentric with the disc itself, the object-glass is properly centered, as it has reference to the tube; but if the misty circle goes to one side of the disc, the cell of the object-glass is not at right angles to the tube, and must have its screws removed and its holes elongated by a rat-tailed file small enough to enter the holes. When this has been done, the cell may be replaced, and the disc examined a second time, and a slight stroke on one edge of the cell by a wooden mallet will show by the alteration made in the position of the misty portion of the disc how the adjustment is to be effected, which is known to be right when a motion in the sliding tube will make the diluted disc

enlarge in a circle concentric with the disc itself. When the disc will enlarge so as to make a ring of diluted white light round its circumference, as the sliding tube holding the eyepiece is pushed in or drawn out, the cell may be finally fixed by the screws passing through its elongated holes.

When the object-glass is thus adjusted, it may then be ascertained whether the curves of the respective lenses composing the object-glass are well formed, and suitable for each other. If a small motion of the sliding tube of about 1-10th of an inch in a 3½ feet telescope from the point of distinct vision will dilute the light of the disc and render the appearance confused, the figure of the object-glass is good, particularly if the same effect will take place at equal distances from the point of distinct vision when the tube is alternately drawn out and pushed in. A telescope that will admit of much motion in the sliding tube, without sensibly affecting the distinctness of vision will not define an object well at any point of adjustment, and must be considered as having an imperfect object-glass, inasmuch as the spherical aberration of the transmitted rays is not duly corrected. The due adjustment of the convex lens or lenses to the concave one will be judged of by the absence of coloration round the enlarged disc, and is a property distinct from the spherical aberration: the achromatism depending on the relative focal distances of the convex and concave lenses is regulated by the relative dispersive powers of the pieces of glass made use of, but the distinctness of vision depends on a good figure of the computed curves that limit the focal distances. When an object-glass is free from imperfection in both these respects, it may be called a good glass for terrestrial purposes.

It still, however, remains to be determined how far such an object-glass may be good for viewing a star or a planet, and can only be known by actual observations on the heavenly bodies. When a good telescope is directed to the moon or to Jupiter, the achromatism may be judged of by alternately pushing in and drawing out the eyepiece from the place of distinct vision. In the former case, a ring of purple will be formed round the edge; and in the latter, a ring of light green, which is the central color of the prismatic spectrum; for these appearances show that the extreme colors, red and violet, are corrected. Again, if one part of a lens employed have a different refractive power from another part of it, that is, if the flint-glass particularly is not homogeneous, a star of the first and even of the second magnitude will point out the natural defect by the exhibition of an irradiation, or what is called a *wing*, at one side, which no perfection of figure or of adjustment will banish, and the greater the aperture, the more liable is the evil to happen: hence caps with different apertures are usually supplied with large telescopes, that the extreme parts of

the glass may be cut off in observations requiring a round and well-defined image of the body observed.

Another method of determining the figure and quality of an object-glass is by first covering its center by a circular piece of paper, as much as one-half of its diameter, and adjusting it for distinct vision of a given object, such as the disc above-mentioned, when the central rays are intercepted, and then trying if the focal length remains unaltered when the paper is taken away and an aperture of the same size applied, so that the extreme rays may in their turn be cut off. If the vision remains equally distinct in both cases, without any new adjustment for focal distance, the figure is good, and the spherical aberration cured, and it may be seen by viewing a star of the first magnitude successively in both cases, whether the irradiation is produced more by the extreme or by the central parts of the glass; or, in case the one-half be faulty and the other good, a semicircular aperture, by being turned gradually round in trial, will detect what semicircle contains the defective portion of the glass; and if such portion should be covered, the only inconvenience that would ensue would be the loss of so much light as is thus excluded. When an object-glass produces radiations in a large star, it is unfit for the nicer observations of astronomy, such as viewing double stars of the first class. The smaller a large star appears in any telescope, the better is the figure of the object-glass; but if the image of the star be free from wings, the size of its disc is not an objection in practical observations.\*

Some opticians are in the habit of inserting a diaphragm into the body of the large tube, to cut off the extreme rays coming from the object-glass when the figure is not good, instead of lessening the aperture by a cap. When this is the case, a deficiency of light will be the consequence beyond what the apparent aperture warrants. It is therefore proper to examine that the diaphragm be not placed too near the object-glass, so as to intercept any of the useful rays. Sometimes a portion of the object-glass is cut off by the stop in the eyetube. To ascertain this, adjust the telescope to distinct vision, then take out the eyeglasses, and put your finger on some other object on the edge of the outside of the object-glass, and look down the tube; if you can see the top of your finger, or any object in its place, just peeping over the edge of the object-glass, no part is cut off. I once had a  $3\frac{1}{2}$  feet telescope whose object-glass measured three inches in diameter, which was neither so bright, nor did it perform in other respects nearly so well as another of the same length whose object-glass was only  $2\frac{3}{4}$  inches in diameter; but I found that a diaphragm was placed about a foot within the end of the large tube, which reduced the aperture of the object-glass to less than  $2\frac{1}{2}$  inches, and when it was removed the telescope was less distinct than before. The powers given along with this instrument were much lower than usual, none of them exceeding 100 times. This is a trick not uncommon with some opticians.

Dr. Pearson mentions that an old Dollond's telescope of 63 inches focal length and  $3\frac{3}{4}$  inches aperture, supposed to be an excellent one, was brought to Mr. Tulley when he was present, and the result of the examination was that its achromatism was not perfect. The imperfection was thus determined by experiment. A small glass

globe was placed at forty yards' distance from the object-end of the telescope when the sun was shining, and the speck of light seen reflected from this globe formed a good substitute for a large star, as an object to be viewed. When the focal length of the object-glass was adjusted to this luminous object, no judgment could be formed of its prismatic aberrations until the eyepiece had been pushed in beyond the place of correct vision; but when the telescope was shortened a little, the luminous disc occasioned by such shortening was strongly tinged with red rays at its circumference. On the contrary, when the eyepieces were drawn out so as to lengthen the telescope too much, the disc thus produced was tinged with a small circle of red at its center, thereby denoting that the convex lens had too short a focal length; and Mr. Tulley observed, that if one or both of the curves of the convex lens were flattened until the total focal length should be about four inches increased, it would render the telescope quite achromatic, provided in doing this the aberration should not be increased.

The following general remarks may be added:

1. To make anything like an accurate comparison of telescopes, they must be tried not only at the same place, but as nearly as possible at the same time, and, if the instruments are of the same length and construction, if possible, with the same eyepiece.
2. A difference of eight or ten times in the magnifying power will sometimes, on certain objects, give quite a different character to a telescope. It has been found by various experiments that object-glasses of two or three inches longer focus will produce different vision with the same eyepiece.
3. Care must be taken to ascertain that the eyeglasses are perfectly clean and free from defects. The defects of glass are either from veins, specks, scratches, color, or an incorrect figure. To discover veins in an eye or an object-glass, place a candle at the distance of four or five yards; then look through the glass, and move it from your eye until it appear full of light; you will then see every vein, or other imperfection in it, which may distort the objects and render vision imperfect. Specks or scratches, especially in object-glasses, are not so injurious as veins, for they do not distort the object, but only intercept a portion of the light.
4. We cannot judge accurately of the excellence of any telescope by observing objects with which we are not familiarly acquainted. Opticians generally try an instrument at their own marks, such as the dial-plate of a watch, a finely engraved card, a weathercock, or the moon and the planet Jupiter, when near the meridian. Of several telescopes of the same length, aperture, and magnifying power, that one is generally considered the best with which we can read a given print at the greatest distance, especially if the print consists of figures, such as a table of logarithms, where the eye is not apt to be deceived by the imagination in guessing at the sense of a passage when two or three words are distinguished.

There is a circumstance which I have frequently noticed in reference to achromatic telescopes, particularly those of a small size, and which I have never seen noticed by any optical writer. It is this: if the telescope, when we are viewing objects, be gradually turned round its axis, there is a certain position in which the objects will appear distinct and accurately defined; and if it be turned round exactly a semicircle from this point, the same degree of distinctness is perceived, but in all other positions there is an evident want of clearness and defining power. This

\* The above directions and remarks are abridged with some alterations from Dr. Pearson's "Introduction to Practical Astronomy," vol. ii.

I find to be the case in more than ten one-foot and two-foot telescopes now in my possession, and therefore I have put marks upon the object-end of each of them to indicate the positions in which they should be used for distinct observation. This is a circumstance which requires, in many cases, to be attended to in the choice and the use of telescopic instruments, and in fixing and adjusting them on their pedestals. In some telescopes this defect is very striking, but it is in some measure perceptible in the great majority of instruments which I have had occasion to inspect. Even in large and expensive achromatic telescopes this defect is sometimes observable. I have an achromatic whose object-glass is 4 1-10th inches in diameter, which was much improved in its defining power by being unscrewed from its original position, or turned round its axis about one-eighth part of its circumference. This defect is best detected by looking at a large printed bill, or a signpost at a distance, when on turning round the telescope or object-glass, the letters will appear much better defined in one position than in another. The position in which the object appears least distinct is when the upper part of the telescope is a quadrant of a circle different from the two positions above stated, or at an equal distance from each of them.

7. *On the mode of determining the magnifying power of Telescopes.*—In regard to refracting telescopes, we have already shown that, when a single eyeglass is used, the magnifying power may be found by dividing the focal distance of the object-glass by that of the eyeglass; but when a Huygenian eyepiece, or a four-glass terrestrial eyepiece, such as is now common in achromatic telescopes, is used, the magnifying power cannot be ascertained in this manner; and in some of the delicate observations of practical astronomy, it is of the utmost importance to know the exact magnifying power of the instrument with which the observations are made, particularly when micrometrical measurements are employed to obtain the desired results. The following is a general method of finding the magnifying powers of telescopes when the instrument called a *dynameter* is not employed, and it answers for refracting and reflecting telescopes of every description.

Having put up a small circle of paper an inch or two in diameter at the distance of about 100 yards, draw upon a card two black parallel lines, whose distance from each other is equal to the diameter of the paper circle; then view through the telescope the paper circle with one eye, and the parallel lines with the other, and let the parallel lines be moved nearer to or farther from the eye, until they seem exactly to cover the small circle viewed through the telescope; the quotient obtained by dividing the distance of the paper circle by the distance of the parallel lines from the eye will be the magnifying power of the telescope. It requires a little practice before this experiment can be performed with accuracy. The one eye must be accustomed to look at an object near at hand, while the other is looking at a more distant object through the telescope. Both eyes must be open at the same time, and the image of the object seen through the telescope must be brought into apparent contact with the real object near at hand. But a little practice will soon enable any observer to perform the experiment with ease and correctness, if the telescope be mounted on a firm stand, and its elevation or depression produced by rack-work.

The following is another method founded on the same principle: Measure the space occupied by a number of the courses, or rows of bricks in

a modern building, which, upon an average, is found to have eight courses in two feet, so that each course or row is three inches. Then cut a piece of paper three inches in height, and of the length of a brick, which is about nine inches, so that it may represent a brick, and fixing the paper against the brick wall, place the telescope to be examined at the distance of about 80 or 100 yards from it. Now, looking through the telescope at the paper with one eye, and at the same time, with the other eye, looking past the telescope, observe what extent of wall the magnified image of the paper appears to cover; then count the courses of bricks in that extent and it will give the magnifying power of the telescope. It is to be observed, however, that the magnifying power determined in this way will be a fraction greater than for very distant objects, as the focal distance of the telescope is necessarily lengthened in order to obtain distinct vision of near objects.

In comparing the magnifying powers of two telescopes, or of the same telescope when different magnifying powers are employed, I generally use the following simple method. The telescopes are placed at eight or ten feet distance from a window, with their eye-ends parallel to each other, or at the same distance from the window. Looking at a distant object, I fix upon a portion of it whose magnified image will appear to fill exactly two or three panes of the window; then, putting on a different power, or looking through another telescope, I observe the same object, and mark exactly the extent of its image on the window-panes, and compare the extent of the one image with the other. Suppose, for example, that the one telescope has been previously found to magnify ninety times, and that the image of the object fixed upon exactly fills three panes of the window, and that with the other power or the other telescope the image fills exactly two panes, then the magnifying power is equal to two-thirds of the former, or sixty times; and were it to fill only one pane, the power would be about thirty times. A more correct method is to place at one side of the window a narrow board two or three feet long, divided into fifteen or twenty equal parts, and observe how many of these parts appear to be covered by the respective image of the different telescopes. Suppose, in the one case, ten divisions to be covered by the image in a telescope magnifying ninety times, and that the image of the same object in another telescope measures six divisions, then its power is found by the following proportion: 10: 90 :: 6: 54; that is, this telescope magnifies 54 times.

Another mode which I have used for determining, to a near approximation, the powers of telescopes, is as follows: Endeavor to find the focus of a single lens which is exactly equivalent to the magnifying power of the eyepiece, whether the Huygenian or the common terrestrial eyepiece. This may be done by taking a small lens, and using it as an object-glass to the eyepiece. Looking through the eyepiece to a window, and holding the lens at a proper distance, observe whether the image of one of the panes exactly coincides with the pane as seen by the naked eye; if it does, then the magnifying power of the eyepiece is equal to that of the lens. If the lens be half an inch in focal length, the eyepiece will produce the same magnifying power as a single lens when used as an eyeglass to the telescope, and the magnifying power will then be found by dividing the focal distance of the object-glass by that of the eyeglass; but if the image of the pane of glass does not exactly coincide with the pane as seen

by the other eye, then proportional parts may be taken by observing the divisions of such a board as described above, or we may try lenses of different focal distances. Suppose, for example, that a lens two inches focal length had been used, and that the image of a pane covered exactly the space of two panes, the power of the eyepiece is then equal to that of a single lens of one inch focal distance.

The following is another mode depending on the same general principle. If a slip of writing-paper one inch long, or a disc of the same material one inch in diameter, be placed on a black ground at from 30 to 50 yards' distance from the object-end of the telescope, and a staff painted white, and divided into inches and parts by strong black lines, be placed vertically near the said paper or disc, the eye that is directed through the telescope, when adjusted for vision, will see the magnified disc, and the other eye, looking along the outside of the telescope, will observe the number of inches and parts that the disc projected on it will just cover, and as many inches as are thus covered will indicate the magnifying power of the telescope, at the distance for which it is adjusted for distinct vision. The solar power, or powers for very distant objects, may be obtained by the following proportion: As the terrestrial focal length at the given distance is to the solar focal length, so is the terrestrial to the solar power. For example, a disc of white paper one inch in diameter was placed on a black board, and suspended on a wall contiguous to a vertical black staff that was graduated into inches by strong white lines, at a distance of 33 yards  $2\frac{1}{2}$  feet, and when the adjustment for vision was made with a 42 inch telescope, the left eye of the observer viewed the disc projected on the staff, while the right eye observed that the enlarged image of the disc covered just  $58\frac{1}{4}$  inches on the staff, which number was the measure of the magnifying power at the distance answering to 33 yards  $2\frac{1}{2}$  feet, which in this case exceeded the solar focus by an inch and a half. Then, according to the above analogy, we have, as  $43.5 : 42 :: 58.5 : 56.5$  nearly. Hence the magnifying power due to the solar focal length of the telescope in question is 56.5, and the distance 33 yards  $2\frac{1}{2}$  feet, is that which corresponds to an elongation of the solar focal distance an inch and a half.\* If we multiply the terrestrial and the solar focal distances together, and divide the product by their difference, we shall again obtain the distance of the terrestrial object from the telescope. Thus,  $\frac{43.5 + 1}{1} = 1218$  inches = 101.5 feet, or 33 yards  $2\frac{1}{2}$  feet.

The magnifying power of a telescope is also determined by measuring the image which the object-glass or the large speculum of a telescope forms at its solar focus. This is accomplished by means of an instrument called a *Dynameter*. This apparatus consists of a strip of mother-of-pearl, marked with equal divisions, from the 1-100th to the 1-1000th of an inch apart, according to the accuracy required. This measure is attached to a magnifying lens in its focus, in order to make the small divisions more apparent. When the power of a telescope is required, the person must measure the clear aperture of the object-glass; then, holding the pearl *dynameter* next the eyeglass, let him observe how many divisions the small circle of light occupies when the instrument is directed to a bright object; then, by

dividing the diameter of the object-glass by the diameter of this circle of light, the power will be obtained.\* The most accurate instrument of this kind is the *Double Image Dynameter*, invented by Ramsden, and another on the same principle now made by Dollond, a particular description of which may be found in Dr. Pearson's "Introduction to Practical Astronomy." The advantage attending these dynameters is, that they do not require any knowledge of the thickness and focal lengths of any of the lenses employed in a telescope, nor yet of their number and relative positions; neither does it make any difference whether the construction be refracting or reflecting, direct or inverting. One operation includes the result arising from the most complicated construction.

I shall only mention further the following method of discovering the magnifying power, which is founded on the same general principle as alluded to above. Let the telescope be placed in such a position opposite the sun that the rays of light may fall perpendicularly on the object-glass; the pencil of rays may be received on a piece of paper, and its diameter measured. Then, as the diameter of the pencil of rays is to that of the object-glass, so is the magnifying power of the telescope.

8. *On cleaning the Lenses of Telescopes.*—It is necessary, in order to distinct vision, that the glasses, particularly the eyeglasses of telescopes, be kept perfectly clean, free of damp, dust, or whatever may impede the transmission of the rays of light; but great caution ought to be exercised in the wiping of them, as they are apt to be scratched or otherwise injured by a rough and incautious mode of cleaning them. They should never be attempted to be wiped unless they really require it; and in this case, they should be wiped carefully and gently with a piece of new and soft lamb's-skin leather; if this be not at hand, a piece of fine silk paper, or fine clean linen may be used as a substitute. The lens which requires to be most particularly attended to is the second glass from the eye, or the field-glass; for if any dust or other impediment be found upon this glass, it is always distinctly seen, being magnified by the glass next the eye. The next glass which requires attention is the fourth from the eye, or that which is next the object. Unless the glass next the eye be very dusty, a few small spots or grains of dust are seldom perceptible. The object-glass of an achromatic should seldom be touched unless damp adheres to it. Care should be taken never to use pocket-handkerchiefs or dirty rags for wiping lenses. From the frequent use of such articles, the glasses of seamen's telescopes get dimmed and scratched in the course of a few years. If the glasses be exceedingly dirty, and if greasy substances are attached to them, they may be soaked in spirits and water, and afterward carefully wiped. In replacing the glasses in their socket, care should be taken not to touch the surfaces with the fingers, as they would be dimmed with the perspiration; they should be taken hold of by the edges only, and carefully screwed into the same cells from which they were taken.

#### ON MEGALASCOPES, OR TELESCOPES FOR VIEWING VERY NEAR OBJECTS.

It appears to have been almost overlooked by opticians and others, that telescopes may be con-

\* Pearson's "Practical Astronomy," vol. ii.

\* The mother-of-pearl dynameter may be purchased for about twelve shillings. See fig. 57, a, b, c, p. 75.



structed so as to exhibit a beautiful and minute view of very near objects, and to produce even a microscopic effect without the least alteration in the arrangement of the lenses of which they are composed. This object is effected simply by making the eyetube of a telescope of such a length as to be capable of being drawn out twelve or thirteen inches beyond the point of distinct vision for distant objects. The telescope is then rendered capable of exhibiting with distinctness all kinds of objects from the most distant to those which are placed within three or four feet of the instrument, or not nearer than double the focal distance of the object-glass. Our telescopes, however, are seldom or never fitted with tubes that slide farther than an inch or two beyond the point of distinct vision for distant objects, although a tube of a longer size than usual, or an additional tube, would cost but a trifling expense.

The following, among many others, are some of the objects on which I have tried many amusing experiments with telescopes fitted up with the long tubes to which I allude. The telescope to which I shall more particularly advert is an achromatic, mounted on a pedestal, having an object-glass about nineteen inches focal length, and  $1\frac{5}{8}$ ths of an inch in diameter, with magnifying powers for distant objects of thirteen and twenty times. When this instrument is directed to a miniature portrait  $3\frac{1}{2}$  inches in length, placed in a good light, at the distance of about eight or ten feet, it appears as large as an oil painting four or five feet long, and represents the individual as large as life. The features of the face appear to stand out in bold relief; and perhaps there is no representation of the human figure that more resembles the living prototype than in this exhibition, provided the miniature is finely executed. In this case the tube requires to be pulled out four or five inches from the point of distinct vision for distant objects, and consequently the magnifying power is proportionably increased. Another class of objects to which such a telescope may be applied is *Perspective Prints*, either of public buildings, streets, or landscapes. When viewed in this way they present a panoramic appearance, and seem nearly as natural as life, just in the same manner as they appear in the Optical Diagonal Machine, or when reflected in a large concave mirror, with this advantage, that while in these instruments the left-hand side of the print appears where the right should be, the objects seen through the telescope appear exactly in their natural position. In this case, however, the telescope should have a small magnifying power, not exceeding five or six times, so as to take in the whole of the landscape. If an astronomical eyepiece be used, the print will require to be inverted.

Other kinds of objects which may be viewed with this instrument are trees, flowers, and other objects in gardens immediately adjacent to the apartment in which we make our observations. In this way we may obtain a distinct view of a variety of rural objects, which we cannot easily approach, such as the buds and blossoms on the tops of trees, and the insects with which they may be infested. There are certain objects on which the telescope may be made to produce a powerful microscopical effect, such as the more delicate and beautiful kinds of flowers, the leaves of trees, and similar objects. In viewing such objects, the telescope may be brought within little more than double the focal distance of the object-glass from the objects to be viewed, and then the magnifying power is very considerably increased. A nosegay

composed of a variety of delicate flowers, or even a single flower, such as the sea pink, makes a splendid appearance in this way. A peacock's feather, or even the fibers on a common quill, appear very beautiful when placed in a proper light. The leaves of trees, particularly the leaf of the plane-tree, when placed against a window-pane, so that the light may shine through them, appear, in all their internal ramifications, more distinct, beautiful, and interesting than when viewed in any other way; and in such views a large portion of the object is at once exhibited to the eye. In this case, the eyepiece of such a telescope as that alluded to requires to be drawn out twelve or fourteen inches beyond the point of distinct vision for objects at a distance, and the distance between these near objects and the object-end of the telescope is only about  $3\frac{1}{2}$  feet.

A telescope having a diagonal eyepiece presents a very pleasant view of near objects in this manner. With an instrument of this kind I have frequently viewed the larger kind of small objects alluded to above, such as the leaves of shrubs and trees, flowers consisting of a variety of parts, the fibers of a peacock's feather, and similar objects. In this case, the object-glass of the instrument, which is  $10\frac{1}{2}$  inches focal length, was brought within 22 inches of the object, and the eye looked down upon it in the same manner as when we view objects in a compound microscope. A common pocket achromatic telescope may be used for the purposes now stated, provided the tube in the eyepiece containing the two lenses next the object be taken out, in which case the two glasses next the eye form an astronomical eyepiece, and the tubes may be drawn out five or six inches beyond the focal point for distant objects, and will produce distinct vision for objects not farther distant than about 20 or 24 inches; but in this case, the objects to be viewed must be inverted, in order that they may be seen in their natural positions when viewed through the instrument. Telescopes of a large size and high magnifying powers may likewise be used with advantage for viewing very near objects in gardens adjacent to the room in which the instruments are placed, provided the sliding tube next the eye has a range of two or three inches beyond the point of vision for distant objects. In this case, a magnifying power of 100 times on a  $3\frac{1}{2}$  or a five feet achromatic produces a very pleasant effect. In making the observations to which I have now alluded, it is requisite in order to distinct vision, and to obtain a pleasing view of the objects, that the instrument should be placed on a pedestal, and capable of motion in every direction. The adjustment for distinct vision may be made either by the sliding tube, or by removing the telescope nearer to or farther from the object.

#### REFLECTIONS ON LIGHT AND VISION, AND ON THE NATURE AND UTILITY OF TELESCOPES.

Light is one of the most wonderful and beneficial, and, at the same time, one of the most mysterious agents in the material creation. Though the sun from which it flows to this part of our system is nearly a hundred millions of miles from our globe, yet we perceive it as evidently, and feel its influence as powerfully, as if it emanated from no higher a region than the clouds. It supplies life and comfort to our physical system, and without its influence and operations on the various objects around us, we could scarcely subsist and participate of enjoyment for a single hour. It is diffused around us on every hand from its

fountain, the sun; and even the stars, though at a distance hundreds of thousands of times greater than that of the solar orb, transmit to our distant region a portion of this element. It gives beauty and fertility to the earth, it supports the vegetable and animal tribes, and is connected with the various motions which are going forward throughout the system of the universe. It unfolds to us the whole scenery of external nature; the lofty mountains and the expansive plains, the majestic rivers and the mighty ocean; the trees, the flowers, the crystal streams, and the vast canopy of the sky, adorned with ten thousands of shining orbs. In short, there is scarcely an object within the range of our contemplation but what is exhibited to our understanding through the medium of light, or at least bears a certain relation to this enlivening and universal agent. When we consider the extreme minuteness of the rays of light, their inconceivable velocity, the invariable laws by which they act upon all bodies, the multifarious phenomena produced by their inflections, refractions, and reflections, while their original properties remain the same; the endless variety of colors they produce on every part of our terrestrial creation, and the facility with which millions of rays pass through the smallest apertures, and pervade substances of great density, while every ray passes forward in the crowd without disturbing another, and produces its own specific impression, we cannot but regard this element as the most wonderful, astonishing, and delightful part of the material creation. When we consider the admirable beauties and the exquisite pleasures of which light is the essential source, and how much its nature is still involved in mystery, notwithstanding the profound investigations of modern philosophers, we may well exclaim with the poet,

"How then shall I attempt to sing of Him  
Who, light himself, in uncreated light  
Invested deep, dwells awfully retired  
From mortal eye or angel's purer ken;  
Whose single smile has, from the first of time,  
Filled, overflowing, all yon lumps of heaven,  
That beam forever through the boundless sky."  
THOMSON.

The eye is the instrument by which we perceive the beautiful and multifarious effects of this universal agent. Its delicate and complicated structure; its diversified muscles; its coats and membranes; its different humors, possessed of different refractive powers; and the various contrivances for performing and regulating its external and internal motions, so as to accomplish the ends intended, clearly demonstrate this organ to be a masterpiece of Divine mechanism—the workmanship of Him whose intelligence surpasses conception, and whose wisdom is unsearchable. "Our sight," says Addison, "is the most perfect and delightful of all our senses. It fills the mind with the largest variety of ideas, converses with its objects at the greatest distance, and continues the longest in action, without being tired or satiated with its proper enjoyments. The sense of feeling can indeed give us a notion of extension, shape, and all other ideas that enter the eye except colors; but, at the same time, it is very much strained, and confined in its operation to the number, bulk, and distance of its particular objects. Our sight seems designed to supply all these defects, and may be considered as a more delicate and diffusive kind of touch, that spreads itself over an infinite multitude of bodies, comprehends the largest figures, and brings into our reach some of the more remote parts of the universe."

Could we suppose an order of beings indued with every human faculty but that of sight, it would appear incredible to such beings, accustomed only to the slow information of touch, that by the addition of an organ consisting of a ball and socket, of an inch in diameter, they might be enabled, in an instant of time, without changing their place, to perceive the disposition of a whole army, the order of a battle, the figure of a magnificent palace, or all the variety of a landscape. If a man were by feeling to find out the figure of the Peak of Teneriff, or even of St. Peter's Church at Rome, it would be the work of a lifetime. It would appear still more incredible to such beings as we have supposed, if they were informed of the discoveries which may be made by this little organ in things far beyond the reach of any other sense, that by means of it we can find our way in the pathless ocean; that we can traverse the globe of the earth, determine its figure and dimensions, and delineate every region of it; yea, that we can measure the planetary orbs, and make discoveries in the sphere of the fixed stars. And if they were further informed that, by means of this same organ, we can perceive the tempers and dispositions, the passions and affections of our fellow-creatures, even when they want most to conceal them; that when the tongue is taught most artfully to lie and dissemble, the hypocrisy should appear in the countenance to a discerning eye; and that by this organ we can often perceive what is straight and what crooked in the mind as well as in the body, would it not appear still more astonishing to beings such as we have now supposed?\*

Notwithstanding these wonderful properties of the organ of vision, the eye, when unassisted by art, is comparatively limited in the range of its powers. It cannot ascertain the existence of certain objects at the distance of three or four miles, nor perceive what is going forward in nature or art beyond such a limit. By its natural powers we perceive the moon to be a globe about half a degree in diameter, and diversified with two or three dusky spots, and that the sun is a luminous body of apparently the same size; that the planets are luminous points, and that about a thousand stars exist in the visible canopy of the sky. But the ten thousandth part of those luminaries which are within the reach of human vision can never be seen by the unassisted eye. Here the TELESCOPE interposes, and adds a new power to the organ of vision, by which it is enabled to extend its views to regions of space immeasurably distant, and to objects, the number and magnitude of which could never otherwise have been surmised by the human imagination. By its aid we obtain a sensible demonstration that space is boundless; that the universe is replenished with innumerable suns and worlds; that the remotest regions of immensity, immeasurably beyond the limits of unassisted vision, display the energies of Creating Power; and that the empire of the Creator extends far beyond what eye hath seen or the human imagination can conceive.

The telescope is an instrument of a much more wonderful nature than what most people are apt to imagine. However popular such instruments now are, and however common a circumstance it is to contemplate objects at a great distance which the naked eye cannot discern, yet, prior to their invention and improvement, it would have appeared a thing most mysterious, if not impossible, that objects at the distance of ten miles

\* Reid's Inquiry into the Human Mind, chap. iv

could be made to appear as if within a few yards of us, and that some of the heavenly bodies could be seen as distinctly as if we had been transported by some superior power hundreds of millions of miles beyond the bounds of our terrestrial habitation. Who could ever have imagined, reasoning *a priori*, that the refraction of light in glass—the same power by which a straight rod appears crooked in water, by which vision is variously distorted, and by which we are liable to innumerable deceptions—that that same power or law of nature, by the operation of which the objects in a landscape appear distorted when seen through certain panes of glass in our windows, that that power should ever be so modified and directed as to extend the boundaries of vision, and enable us clearly to distinguish scenes and objects at a distance a thousand times beyond the natural limits of our visual organs? Yet such are the discoveries which science has achieved, such the powers it has brought to light, that by glasses ground into different forms, and properly adapted to each other, we are enabled, as it were, to contract the boundaries of space, to penetrate into the most distant regions, and to bring within the reach of our knowledge the most sublime objects in the universe.

When Pliny declared in reference to Hipparchus, the ancient astronomer, "*Ausus rem Deo improbam annumerare posteris stellas*," that "he dared to enumerate the stars for posterity, an undertaking forbidden by God," what would that natural historian have said had it been foretold that in less than 1600 years afterward a man would arise who should enable posterity to perceive and to enumerate ten times more new stars than Hipparchus ever beheld—who should point out higher mountains on the moon than on the earth—who should discover dark spots as large as our globe in the sun, the fountain of light—who should descry four moons revolving in different periods of time around the planet Jupiter, and could show to surrounding senators the varying phases of Venus? and that another would soon after arise who should point out a double ring of six hundred thousand miles in circumference revolving around the planet Saturn, and ten hundreds of thousands of stars which neither Hipparchus nor any of the ancient astronomers could ever descry? Yet these are only a small portion of the discoveries made by Galileo and Herschel by means of the telescope. Had any one prophetically informed Archimedes, the celebrated geometrician of Syracuse, that vision would, in after ages, be thus wonderfully assisted by art; and, further, that one manner of improving vision would be to place a dark, *opaque* body directly between the object and the eye; and that another method would be, not to look at the object, but to keep the eye quite in a different, and even in an opposite direction, or to stand with the back directly opposed to it, and to behold all the parts of it, invisible to the naked eye, most distinctly in this way, he would doubtless have considered the prophet as an enthusiastic fool or a raving madman. Yet these things have been realized in modern times in the fullest extent. In the Gregorian reflecting telescope, an opaque body, namely, the small speculum near the end of the tube, interposes directly between the eye and the object. In the Newtonian reflector, and in the diagonal eyepieces formerly described, the eye is directed in a line at right angles to the object, or a deviation of 90 degrees from the direct line of vision. In Herschel's large telescopes, and in the *Aerial Reflector*, formerly described (in pp. 88-92),

the back is turned to the object, and the eye in an opposite direction.

These circumstances should teach us humility and a becoming confidence in our own powers; and they should admonish us not to be too dogmatical or peremptory in affirming what is possible or impossible in regard either to nature or art or to the operations of the Divine Being. Art has accomplished, in modern times, achievement, in regard to locomotion, marine and aerial navigation, the improvement of vision, the separation and combinations of invisible gases, and numerous other objects, of which the men of former ages could not have formed the least conception; and even yet we can set no boundaries to the future discoveries of science and the improvements of art, but have every reason to indulge the hope that, in the ages to come, scenes of Divine mechanism in the system of nature will be unfolded, and the effects of chemical and mechanical powers displayed, of which the human mind, in its present state of progress, cannot form the most imperfect idea. Such circumstances likewise should teach us not to reject any intimations which have been made to us in relation to the character, attributes, and dispensations of the Divine Being, and the moral revelations of his will given in the Sacred Records, because we are unable to comprehend every truth and to remove every difficulty which relates to the moral government of the Great Ruler of the universe; for if we meet with many circumstances in secular science, and even in the common operations of nature, which are difficult to comprehend—if even the construction of such telescopes as we now use would have appeared an incomprehensible mystery to ancient philosophers, we must expect to find difficulties almost insurmountable to such limited minds as ours in the eternal plans and moral arrangements of the "King Immortal and Invisible," as delineated only in their outlines in the Sacred Oracles, particularly those which relate to the origin of physical and moral evil, the ultimate destiny of man, and the invisible realities of a future world.

The utility of the telescope may be considered in relation to the following circumstances:

In the first place, it may be considered as an instrument or machine which virtually transports us to the distant regions of space. When we look at the moon through a telescope which magnifies 200 times, and survey its extensive plains, its lofty peaks, its circular ranges of mountains, throwing their deep shadows over the vales, its deep and rugged caverns, and all the other varieties which appear on the lunar surface, we behold such objects in the same manner as if we were standing at a point 238,800 miles from the earth in the direction of the moon, or only twelve hundred miles from that orb, reckoning its distance to be 240,000 miles. When we view the planet Saturn with a similar instrument, and obtain a view of its belts and satellites, and its magnificent rings, we are transported, as it were, through regions of space to a point in the heavens more than *nine hundred millions of miles* from the surface of our globe, and contemplate those august objects as if we were placed within five millions of miles of the surface of that planet.\* Although

\* The distance of Saturn from the sun is 906,000,000 of miles; it is sometimes nearer to, and at other times farther from the earth, according as it is near the point of its opposition to, or conjunction with, the sun. If this number be divided by 200 hundred, the supposed magnifying power of the telescope, the quotient is 4,530,000, which expresses the distance in miles at which it enables us to contemplate this

a supernatural power sufficient to carry us in such a celestial journey a thousand miles every day were exerted, it would require more than two thousand four hundred and sixty years before we could arrive at such a distant position; yet the telescope, in a few moments, transports our visual powers to that far distant point of space. When we view with such an instrument the minute and very distant clusters of stars in the Milky Way, we are carried, in effect, through the regions of space to the distance of *five hundred thousand millions of miles* from the earth; for we behold those luminaries through the telescope nearly as if they were actually viewed from such a distant point in the spaces of the firmament. These stars cannot be conceived as less than a *hundred billions* of miles from our globe, and the instrument we have supposed brings them within the two hundredth part of this distance. Suppose we were carried forward by a rapid motion toward this point at the rate of a thousand miles *every hour*, it would require more than *fifty-seven thousand years* before we could reach that very distant station in space to which the telescope, *in effect*, transports us: so that this instrument is far more efficient in opening to our view the scenes of the universe than if we were invested with powers of locomotion to carry us through the regions of space with the rapidity of a cannon ball at its utmost velocity; and all the while we may sit at ease in our terrestrial apartments.

In the next place, the telescope has been the *means of enlarging our views of the sublime scenes of creation* more than any other instrument which art has contrived. Before the invention of this instrument, the universe was generally conceived as circumscribed within very narrow limits. The earth was considered as one of the largest bodies in creation; the planets were viewed as bodies of a far less size than what they are now found to be; no bodies similar to our moon were suspected as revolving around any of them; and the stars were supposed to be little more than a number of brilliant lamps hung up to emit a few glimmering rays, and to adorn the canopy of our earthly habitation. Such a wonderful phenomenon as the ring of Saturn was never once suspected, and the sun was considered as only a large ball of fire. It was suspected, indeed, that the moon was diversified with mountains and vales, and that it might possibly be a habitable world; but nothing certainly could be determined on this point on account of the limited nature of unassisted vision. But the telescope has been the means of expanding our views of the august scenes of creation to an almost unlimited extent: it has withdrawn the veil which formerly interposed to intercept our view of the distant glories of the sky: it has brought to light five new planetary bodies, unknown to former astronomers, one of which is more than eighty times larger than the earth, and seventeen *secondary* planets which revolve around the primary: it has expanded the dimensions of the solar system to double the extent which was formerly supposed: it has enabled us to descry hundreds of comets which would otherwise have escaped our unassisted vision, and to determine some of their trajectories and periods of revolution: it has explored the profundities of the Milky Way, and enabled us to perceive hundreds of thousands of those splendid orbs, where scarcely a planet. If this number be subtracted from 965,000,000, the remainder is 903,470,000, which expresses the number of stars seen from the earth at which we are supposed to view Saturn with such an instrument.

one is visible to the naked eye: it has laid open to our view thousands of *Nebulae*, of various descriptions, dispersed through different regions of the firmament, many of them containing thousands of separate stars: it has directed our investigations to thousands of double, treble, and multiple stars—suns revolving around suns, and systems around systems; and has enabled us to determine some of the periods of their revolutions: it has demonstrated the immense distances of the stary orbs from our globe, and their consequent magnitudes, since it shows us that, having brought them nearer to our view by several hundreds or thousands of times, they still appear only as so many shining *points*: it has enabled us to perceive that mighty changes are going forward throughout the regions of immensity—new stars appearing, and others removed from our view, and motions of incomprehensible velocity carrying forward those magnificent orbs through the spaces of the firmament: in short, it has opened a vista to regions of space so immeasurably distant, that a cannon ball impelled with its greatest velocity would not reach tracts of creation so remote in two thousand millions of years; and even light itself, the swiftest body in nature, would require more than a thousand years before it could traverse this mighty interval. It has thus laid a foundation for our acquiring an approximate idea of the infinity of space, and for obtaining a glimpse of the far distant scenes of creation, and the immense extent of the universe.

Again, the telescope, in consequence of the discoveries it has enabled us to make, has tended to *amplify our conceptions of the attributes and the empire of the Deity*. The amplitude of our conceptions of the Divine Being bears a certain proportion to the expansion of our views in regard to his works of creation, and the operations he is incessantly carrying forward throughout the universe. If our views of the works of God, and of the manifestations he has given of himself to his intelligent creatures, be circumscribed to a narrow sphere, as to a parish, a province, a kingdom, or a single world, our conceptions of that Great Being will be proportionably limited; for it is chiefly from the manifestation of God in the material creation that our ideas of his power, his wisdom, and his other natural attributes are derived. But in proportion to the ample range or prospect we are enabled to take of the operations of the Most High, will be our conceptions of his character, attributes, and agency. Now the telescope, more than any other invention of man, has tended to open to our view the most magnificent and extensive prospects of the works of God; it has led us to ascertain that, within the limits of the solar system, there are bodies which, taken together, comprise a mass of matter nearly two thousand five hundred times greater than that of the earth; that these bodies are all constituted and arranged in such a manner as to fit them for being habitable worlds; and that the sun, the center of this system, is five hundred times larger than the whole. But, far beyond the limits of this system, it has presented to our view a universe beyond the grasp of finite intelligences, and to which human imagination can assign no boundaries: it has enabled us to descry suns clustering behind suns, rising to view in boundless perspective, in proportion to the extent of its magnifying and illuminating powers, the numbers of which are to be estimated, not merely by thousands, and tens of thousands, and hundreds of thousands, but by scores of *millions*; leaving us no room to doubt that hundreds

of millions more beyond the utmost limits of human vision, even when assisted by art, lie hid from mortal view in the unexplored and unexplorable regions of immensity.

Here, then, we are presented with a scene which gives us a display of *Omnipotent Power* which no other objects can unfold, and which, without the aid of the telescope, we should never have beheld; a scene which expands our conceptions of the Divine Being to an extent which the men of former generations could never have anticipated; a scene which enables us to form an approximate idea of Him who is the "King Eternal, Immortal, and Invisible," who "created all worlds, and for whose pleasure they are and were created." Here we behold the operations of a Being whose power is illimitable and uncontrollable, and which far transcends the comprehension of the highest created intelligences; a power, displayed not only in the vast extension of material existence, and the countless number of mighty globes which the universe contains, but in the astonishingly *rapid motions* with which myriads of them are carried along through the immeasurable spaces of creation, some of those magnificent orbs moving with a velocity of one hundred and seventy thousand miles an hour. Here, likewise, we have a display of the infinite *wisdom* and intelligence of the Divine Mind, in the harmony and order with which all the mighty movements of the universe are conducted; in proportionating the magnitudes, motions, and distances of the planetary worlds; in the nice adjustment of the projectile velocity to the attractive power; in the constant proportion between the times of the periodical revolution of the planets and the cubes of their mean distances; in the *distances* of the several planets from the central body of the system, compared with their respective *densities*; and in the constancy and regularity of their motions, and the exactness with which they accomplish their destined rounds—all which circumstances evidently show that He who contrived the universe is "the only wise God," who is "wonderful in counsel and excellent in working." Here, in fine, is a display of *boundless benevolence*; for we cannot suppose, for a moment, that so many myriads of magnificent globes, fitted to be the centers of a countless number of mighty worlds, should be nothing else than barren wastes, without the least relation to intelligent existence; and if they are peopled with intellectual beings of various orders, how vast must be their numbers, and how overflowing that Divine Beneficence which has provided for them all everything requisite to their existence and happiness.

In these discoveries of the telescope we obtain a glimpse of the grandeur and the unlimited extent of God's universal empire. To this empire no boundaries can be perceived. The larger and the more powerful our telescopes are, the farther are we enabled to penetrate into those distant and unknown regions; and however far we penetrate into the abyss of space, new objects of wonder and magnificence still continue rising to our view, affording the strongest presumption that, were we to penetrate ten thousand times farther into those remote spaces of immensity, new suns, and systems, and worlds would be disclosed to our view. Over all this vast assemblage of material existence, and over all the sensitive and intellectual beings it contains, God eternally and unchangeably presides; and the minutest movements, either of the physical or the intelligent system, throughout every department of those vast dominions, are at every moment "naked and open" to his

omniscient eye. What *boundless intelligence* is implied in the *superintendence* and *arrangement* of the affairs of such an unlimited empire! and what a lofty and expansive idea does it convey of Him who sits on the throne of Universal Nature, and whose greatness is unsearchable! But without the aid of the telescopic tube we could not have formed such ample conceptions of the greatness, either of the Eternal Creator himself, or of the universe which he hath brought into existence.

Beside the above, the following uses of the telescope, in relation to science and common life, may be shortly noticed:

In the business of astronomy, scarcely anything can be done with accuracy without the assistance of the telescope. 1. It enables the astronomer to determine with precision the *transits of the planets and stars* across the meridian; and on the accuracy with which these transits are obtained, a variety of important conclusions and calculations depend. The computation of astronomical and nautical tables for aiding the navigator in his voyages round the globe, and facilitating his calculations of latitude and longitude, is derived from observations made by the telescope, without the use of which instrument they cannot be made with precision. 2. The *apparent diameters of the planets* can only be measured by means of this instrument, furnished with a micrometer. By the naked eye no accurate measurements of the diameters of these bodies can be taken; and without knowing their apparent diameters in minutes or seconds, their real bulk cannot be determined, even although their exact distances be known. The differences, too, between the polar and equatorial diameters cannot be ascertained without observations made by powerful telescopes. For example, the equatorial diameter of Jupiter is found to be in proportion to the polar as 14 to 13, that is, the equatorial is more than 6000 miles longer than the polar diameter, which could never have been determined by observations made by the naked eye. 3. The *parallaxes* of the heavenly bodies can only be accurately ascertained by the telescope; and it is only from the knowledge of their parallaxes that their distances from the earth or from the sun can be determined. In the case of the fixed stars, nothing of the nature of a parallax could ever be expected to be found without the aid of a telescope. It was by searching for the parallax of a certain fixed star that the important fact of the *Aberration of Light* was discovered. The observations for this purpose were made by means of a telescope 24 feet long, fixed in a certain position. 4. The motions and revolutionary periods of *Sidereal Systems* can only be determined by observations made by telescopes of great magnifying and illuminating powers. Without a telescope the small stars which accompany double or treble stars cannot be perceived, and much less their motions or variation of their relative positions. Before the invention of the telescope, such phenomena, now deemed so wonderful, and interesting, could never have been surmised. 5. The accurate determination of the longitude of places on the earth's surface is ascertained by the telescope, by observing with this instrument the immersions and emersions of the satellites of Jupiter. From such observations, with the aid of a chronometer, and having the time at any known place, the situation of any unknown place is easily determined. But the eclipses of Jupiter's moons can be perceived only by telescopic instruments of considerable power. 6. By means of a telescope with cross hairs in the focus of the eyeglass, and attached to a quadrant, the altitude of

the sun or of a star, particularly the pole-star, may be most accurately taken, and from such observations the *latitude* of the place may be readily and accurately deduced.

Again, in the *Surveying of Land*, the telescope is particularly useful; and for this purpose it is mounted on a stand with a horizontal and vertical motion, pointing out by divisions the degrees and minutes of inclination of the instrument. For the more accurate reading of these divisions, the two limbs are furnished with a nonius, or *Vernier's Scale*. The object here is to take the angular distances between distant objects on a plane truly horizontal, or else the angular elevation or depression of objects above or below the plane of the horizon. In order to obtain either of those kinds of angles to a requisite degree of exactness, it is necessary that the surveyor should have as clear and distinct a view as possible of the objects, or station-staves, which he fixes up for his purpose, that he may with the greater certainty determine the point of the object which exactly corresponds with the line he is taking. Now, as such objects are generally at too great a distance for the surveyor to be able to distinguish with the naked eye, he takes the assistance of the telescope, by which he obtains, 1, a distinct view of the object to which his attention is directed, and, 2, he is enabled to determine the precise point of the object aimed at by means of the cross hairs in the focus of the eyeglass. A telescope mounted for this purpose is called a *Theodolite*, which is derived from two Greek words, *θεωμαι*, to see, and *ωδος*, the way or distance.

In the next place, the telescope is an instrument of special importance in the conducting of *Telegraphs*, and in the conveyance of *signals* of all descriptions. Without its assistance telegraphic dispatches could not be conveyed with accuracy to any considerable distance, nor in quadruple the time in which they are now communicated, and the different stations would need to be exceedingly numerous: but, by the assistance of the telescope, information may be communicated, by a series of telegraphs, with great rapidity. Twenty-seven telegraphs convey information from Paris to Calais, a distance of 160 miles, in three minutes; twenty-two, from Paris to Lisle, in two minutes; forty-six, from Strasburg to Paris, in four and a half minutes; and eighty, from Paris to Brest, in ten minutes. In many other cases which occur both on land and sea, the telescope is essentially requisite for descreyng signals. The *Bell-Rock Lighthouse*, for example, is situated twelve miles from Arbroath, and from every other portion of land, so that the naked eye could not discern any signal which the keepers of that light could have it in their power to make; but by means of a large telescope in the station-house in Arbroath, the hoisting of a ball every morning at 9, A. M., which indicates that "All is well," may be distinctly recognized.

Many other uses of this instrument, in the ordinary transactions of life, will readily occur to the reader, and therefore I shall only mention the following purpose to which it may be applied, namely,

*To measure the Distance of an Object from one*

*Station.*—This depends upon the increase of the focal distance of the telescope in the case of near objects. Look through a telescope at the object whose distance is required, and adjust the focus until it appears quite distinct; then slide in the drawer until the object begins to be obscure, and mark that place of the tube precisely; next draw out the tube until the object begins to be again obscured, and then make another mark as before; then take the middle point between these two marks, and that will be the point where the image of the object is formed most distinctly, which is to be nicely measured from the object-lens, and compared with the solar focus of the lens or telescope, so as to ascertain their difference. And the rule for finding the distance is: as the difference between the focal distance of the object and the solar focal distance is to the solar focal distance, so is the focal distance of the object to its true distance from the object-lens. An example will render this matter more perspicuous:

Fig. 84.

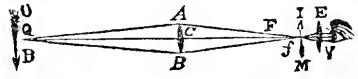

Let  $AB$  (fig. 84) be the object-lens,  $EY$  the eyeglass,  $FC$  the radius, or focus of the lens  $AB$ , and  $Cf$  the focal distance of the object  $OB$ , whose distance is to be measured. Now suppose  $Cf=48$  inches, or four feet, and that we find by the above method that  $Cf$  is 50 inches, then  $Ff$  is two inches; and the analogy is, as  $Ff=2$  is to  $Cf=48$ , so is  $CQ=1200$  inches, or 100 feet. Again, suppose  $Cf=49$  inches, then will  $Ff=1$  inch; and the proportion is, 1 : 49 :: 49 : 2552 =  $QC$ , or 196 feet. A telescope of this focal length, however, will measure only small distances. But suppose  $AB$  a lens whose solar focus is 12 feet, or 144 inches, and that we find by the above method that  $Cf$ , or the focal distance of the object, is 146 inches, then will  $Ff$  be two inches, and the proportion will be as 2 : 144 : : 146 : 21024 inches, or 1752 feet—the distance  $QC$ . If with such a large telescope we view an object  $OB$ , and find  $Ff$  but 1-10th of an inch, this will give the distance of the object as 17,292 feet, or nearly 31 $\frac{1}{3}$  miles.

Since the difference between the radius of the object-lens and the focal distance of the object is so considerable as two inches in a tube of four feet, and more than twelve inches in one of twelve feet, a method might be contrived for determining the distance of near objects by the former, and more distant objects by the latter, by inspection only. This may be done by adjusting or drawing a spiral line round the drawer or tube through the *two-inch space* in the small telescope, and by calculation graduate it for every 100 feet and the intermediate inches, and then, at the same time we view an object, we may see its distance on the tube. In making such experiments, a common object-glass of a long focal length, and a single eyeglass, are all that is requisite, since the inverted appearance of the object can cause no great inconvenience.

## CHAPTER VII.

### ON THE METHOD OF GRINDING AND POLISHING OPTICAL LENSES AND SPECULA.

I ORIGINALLY intended to enter into particular details on this subject for the purpose of gratifying those mechanics and others who wish to amuse themselves by constructing telescopes and other optical instruments for their own use; but, having dwelt so long on the subject of telescopes in the preceding pages, I am constrained to confine myself to a very general sketch.

1. *To grind and polish Lenses for Eyeglasses, Microscopes, &c.*—First provide an upright spindle, at the bottom of which a pulley is fixed, which must be turned by a wheel by means of a cord and handle. At the top of the spindle make a screw the same as a lathe-spindle, on which you may screw chucks of different sizes, to which the brass tool in which the lens is to be ground may be fixed. Having fixed upon the breadth and focal length of the lens, and whether it is to be a plano or a double convex, take a piece of tin-plate or sheet copper, and with a pair of compasses draw an arch upon its surface, near one of its extremities, with a radius equal to the focal distance of the lens, if intended to be double-convex, or with half that distance if it is to be plano-convex. Remove with a file that part of the copper which is without the circular arch, and then a *convex gauge* is formed. With the same radius strike another arch, and having removed that part of the copper which is *within* it, a *concave gauge* will be obtained. The brass tool in which the glass is to be ground is then to be fixed upon a turning-lathe, and turned into a portion of a concave sphere, so as to correspond to the convex gauge. In order to obtain an accurate figure to the concave tool, a convex tool of exactly the same radius is generally formed, and they are ground one upon another with flour of emery, and when they exactly coincide they are fit for use. The convex tool will serve for grinding *concave* glasses of the same radius; and it should be occasionally ground in the concave tool to prevent it from altering its figure.

The next thing to be attended to is to prepare the piece of glass which is to be ground, by chipping it in a circular shape by means of a large pair of scissors, and removing the roughness from its edges by a common grindstone. The faces of the glass near the edges should likewise be ground on the grindstone until they nearly fit the concave gauge, by which the labor of grinding in the tool will be considerably saved. The next thing required is to prepare the emery for grinding, which is done in the following manner: Provide four or five clean earthen vessels: fill one of them with water, and put into it a pound or half a pound of fine emery, and stir it about with a stick; after which, let it stand three or four seconds, and then pour it into another vessel, which may stand about ten seconds: then pour it off again into the several vessels until the water is quite clear, and by this means emery of different degrees of fineness is obtained, which must

be kept separate from each other, and worked in their proper order, beginning at the first, and working off all the marks of the grindstone; then take of the second, next of the third, &c., holding the glass upon the pan or tool with a light hand when it comes to be nearly fit for polishing. The glass, in this operation, should be cemented to a wooden handle by means of pitch or other strong cement. After the finest emery has been used, the roughness which remains may be taken away, and a slight polish given, by grinding the glass with pounded pumice-stone. Before proceeding to the polishing, the glass should be ground as smooth as possible, and all the scratches erased, otherwise the polishing will become a tedious process. The polishing is performed as follows: Tie a piece of linen rag or fine cloth about the tool, and with fine putty (calined tin) or colcothar of vitriol (a very fine powder, sometimes called the red oxide of iron), moistened with water, continue the grinding motion, and in a short time there will be an excellent polish.

In order to grind lenses very accurately for the finest optical purposes, particularly object-glasses for telescopes, the concave tool is firmly fixed to a table or bench, and the glass wrought upon it by the hand with circular strokes, so that its center may never go beyond the edges of the tool. For every six or seven circular strokes, the glass should receive two or three cross-ones along the diameter of the tool, and in different directions; and, while the operation is going on, the convex tool should, at the end of five minutes, be wrought upon the concave one for a few seconds, in order to preserve the same curvature to the tools and to the glass. The finest polish is generally given in the following way: Cover the concave tool with a layer of pitch, hardened by the addition of a little resin, to the thickness of 1-15th of an inch; then, having taken a piece of thin writing paper, press it upon the surface of the pitch with the convex tool, and pull the paper quickly from the pitch before it has adhered to it; and if the surface of the pitch is marked everywhere with the lines of the paper, it will be truly spherical. If any paper remains on the surface of the pitch, it may be rubbed off by soap and water; and if the marks of the paper should not appear on any part of it, the operation must be repeated until the polisher or bed of pitch is accurately spherical. The glass is then to be wrought on the polisher by circular and cross strokes with the putty or co'colthar until it has received a complete polish. When one side is finished, the glass must be separated from its handle by inserting the point of a knife between it and the pitch, and giving it a gentle stroke. The pitch which remains upon the glass may be removed by rubbing it with a little oil, or spirits of wine. The operation of polishing on cloth is slower, and the polish less perfect than on pitch; but it is a mode best fitted for those who have little experience, and who would be apt, in

the first instance, to injure the figure of the lens by polishing it on a bed of pitch.

2. *On the method of casting and grinding the Specula of Reflecting Telescopes.*—The first thing to be considered in the formation of reflecting telescopes is the composition of the metal of which the specula are made. The qualities required are, a sound, uniform metal, free from all microscopic pores, not liable to tarnish by absorption of moisture from the atmosphere—not so hard as to be incapable of taking a good figure and polish, nor so soft as to be easily scratched, and possessing a high reflecting power. Various compositions have been used for this purpose, of which the following are specimens: Take of good Swedish copper 32 ounces, and when melted, add 14½ ounces of grain tin to it; then, having taken off the scoria, cast it into an ingot. This metal must be a second time melted to cast a speculum; but it will fuse in this compound state with a small heat, and therefore will not calcine the tin to putty. It should be poured off as soon as it is melted, giving it no more heat than is absolutely necessary. The best method for giving the melted metal a good surface is this: the moment before it is poured off, throw into the crucible a spoonful of charcoal-dust; immediately after which, the metal must be stirred with a wooden spatula and poured into the molds. The following is another composition somewhat similar: Take two parts of copper as pure as it is possible to procure: this must be melted in a crucible by itself; then put, in another crucible, one part of pure grain tin: when they are both melted, mix and stir them with a wooden spatula, keeping a good flux on the melted surface to prevent oxidation, and then pour the metal quickly into the molds, which may be made of founders' loam.

The composition suggested, more than half a century ago, by the Rev. Mr. Edwards, has often been referred to with peculiar approbation. This gentleman took a great deal of pains to discover the best composition; and to give his metals a fine polish and the true parabolical figure. His telescopes were tried by Dr. Maskelyne, the astronomer royal, who found them greatly to excel in brightness, and to equal in other respects those made by the best artists. They showed a white object perfectly white, and all objects of their proper color. He found, after trying various combinations, the following to be the best, namely, 32 ounces of copper, with 15 or 16 ounces of grain tin (according to the purity of the copper), with the addition of one ounce of brass, one of silver, and one ounce of arsenic. This, he affirms, will form a metal capable, when polished in a proper manner, of reflecting more light than any other metal yet made public.

The Rev. J. Little, in his observations on this subject in the "Irish Transactions," proposes the following composition, which he found to answer the purpose better than any he had tried, namely, 32 parts of best bar copper, previously fluxed with the black flux of 2 parts tartar and 1 of niter, 4 parts of brass, 16 parts of tin, and 11½ of arsenic. If the metal be granulated, by pouring it, when first melted, into water, and then fused a second time, it will be less porous than at first. In this process, the chief object is to hit on the exact point of the saturation of the copper, &c., by the tin; for if the latter be added in too great quantity, the metal will be dull colored and soft; if too little, it will not attain the most perfect whiteness, and will certainly tarnish.<sup>b</sup>

<sup>a</sup> *Irish Transactions*, vol. x; and Nicholson's *Philosophical Journal*, vol. xvi.

When the metal is cast, and prepared by the common grindstone for receiving its proper figure, the gauges and grinding-tools are to be formed in the same manner as formerly described for lenses, with this difference, that the radius of the gauges must always be double the focal length of the speculum, as the focus of parallel rays by reflection is at one half the radius of concavity. In addition to the concave and convex tools, which should be only a little broader than the metal itself, a convex elliptical tool of lead and tin should be formed with the same radius, so that its transverse should be to its conjugate diameter as 10 to 9, the latter being exactly equal to the diameter of the metal. The grinding of the speculum is then to be commenced on this tool with coarse emery powder and water, when the roughness is taken off by moving the speculum across the tool in different directions, walking round the post on which the tool is fixed, holding the speculum by the wooden handle to which it is cemented; it is then to be wrought with great care on the convex brass tool, with circular and cross strokes, and with emery of different degrees—the concave tool being sometimes ground upon the convex one, to keep them all of the same radius—and when every scratch is removed from its surface, it will be fit for receiving the final polish.

When the metal is ready for polishing, the elliptical tool is to be covered with black pitch about 1-20th of an inch thick, and the polisher formed in the same way as in the case of lenses either with the concave brass tool or with the metal itself. The colcothar of vitriol should then be triturated between two surfaces of glass, and a considerable quantity of it applied at first to the surface of the polisher. The speculum is then to be wrought in the usual way upon the polishing tool until it has received a brilliant luster, taking care to use no more of the colcothar, if it can be avoided, and only a small quantity of it, if it should be found necessary. When the metal moves stidily on the polisher, and the colcothar assumes a dark, muddy hue, the polish advances with great rapidity. The tool will then grow warm, and would probably stick to the speculum if its motion were discontinued for a moment. At this stage of the process, therefore, we must proceed with great caution, breathing continually on the polisher until the friction is so great as to retard the motion of the speculum. When this happens, the metal is to be slipped off the tool at one side, cleaned with soft leather, and placed in a tube for the purpose of trying its performance; and if the polishing has been conducted with care, it will be found to have a true parabolical figure.\*

It was formerly the practice, before the speculum was brought to the polisher, to smooth it on a bed of hones, or a convex tool made of the best blue stone, such as clockmakers use in polishing their work, which was made one-fourth part larger than the metal which was to be ground upon it, and turned as true as possible to a gauge; but this tool is not generally considered as absolutely necessary, except when silver and brass enter into the composition of the metal, in order to remove the roughness which remains after grinding with the emery.

*To try the Figure of the Metal.*—In order to this, the speculum must be placed in the tube of the telescope for which it is intended, and at about 20 or 30 yards distant there should be put up a watch-paper, or similar object, on which there are some very fine strokes of an engraver.

\* Brewster's Appendix to "Ferguson's Lectures."



An annular kind of diagram should be made with card-paper, so as to cover a circular portion of the middle part of the speculum, between the hole and the circumference, equal in breadth to about one-eighth of its diameter. This paper ring should be fixed in the mouth of the telescope, and remain so during the whole experiment. There must likewise be two other circular pieces of card-paper cut out, of such sizes that one may cover the center of the metal by completely filling the hole in the annular piece now described, and the other such a round piece as shall exactly fill the tube, and so broad as that the inner edge just touches the outward circumference of the middle annular piece. All these pieces together will completely shut up the mouth of the telescope. Let the round piece which covers the center of the metal be removed, and adjust the instrument so that the image may be as sharp and distinct as possible; then replace the central piece, and remove the outside annular one, by which means the circumference only of the speculum will be exposed, and the image now formed will be from the rays reflected from the exterior side of the metal. If the two images formed by these two portions of the metal be perfectly sharp and equally distinct, the speculum is perfect and of the true parabolic curve; if, on the contrary, the image from the outside of the metal should not be distinct, and it should be necessary to bring the little speculum *nearer* by the screw, the metal is not yet brought to the parabolic figure; but if, in order to procure distinctness, we be obliged to move the small speculum farther off, then the figure of the great speculum has been carried beyond the parabolic, and has assumed the hyperbolic form.

*To adjust the Eyehole of Gregorian Reflectors.*—If there is only one eyeglass, then the distance of the small hole, should be as nearly as possible equal to its focal length; but in the compound Huygenian eyepiece, the distance of the eyehole may be thus found: Multiply the difference between the focal distance of the glass next to the speculum, and the distance of the two eyeglasses, by the focal distance of the glass nearest the eye; divide the product by the sum of the focal distances of the two lenses, lessened by their distance, and the quotient will be the compound focal distance required. Thus, if the focal distance of the lens next the speculum be three inches, that of the lens

next the eye one inch, and their distance two inches, then the compound focal distance from the eyeglass will be  $\frac{3-2+1}{3-1+2} = 1\frac{1}{2}$  inch. The diameter of the eyehole is always equal to the quotient obtained by dividing the diameter of the great speculum by the magnifying power of the telescope. It is generally from 1-25th to 1-50th of an inch in diameter. It is necessary, in many cases, to obtain from *direct experimental* an accurate determination of the place and size of the eyehole, as on this circumstance depends, in a certain degree, the accurate performance of the instrument.

*To center the two specula of Gregorian Reflectors.*—Extend two fine threads or wires across the aperture of the tube at right angles, so as to intersect each other exactly in the axis of the telescope. Before the arm is finally fastened to the slider, place it in the tube, and through the eyepiece (without glasses) the intersection of the cross-wires must be seen exactly in the center of the hole of the arm. When this exactness is obtained, let the arm be firmly riveted and soldered to the slider.

*To center Lenses.*—The centering of lenses is of great importance, more especially for the object-glasses of achromatic instruments. The following is reckoned a good method: Let the lens to be centered be cemented on a brass chock, having the middle turned away so as not to touch the lens except near the edge, which will be hid when mounted. This rim is very accurately turned flat where it is to touch the glass. When the chock and cement is warm, it is made to revolve rapidly; while in motion, a lighted candle is brought before it, and its reflected image attentively watched. If this image has any motion, the lens is not flat or central; a piece of soft wood must therefore be applied to it in the manner of a turning tool, until such time as the light becomes stationary. When the whole has cooled, the edges of the lens must be turned by a diamond, or ground with emery.

For more particular details in reference to grinding and polishing specula and lenses, the reader is referred to Smith's "Complete System of Optics," Inison's "School of Arts," *Humboldt's Opera*, Brewster's Appendix to "Ferguson's Lectures," "Irish Transactions," vol. x. or "Nicholson's Journal," vol. xvi, Nos. 65, 66, for January and February, 1807.

## PART III.

### ON VARIOUS ASTRONOMICAL INSTRUMENTS.

#### CHAPTER I.

##### ON MICROMETERS.

A MICROMETER is an instrument attached to a telescope, in order to measure small spaces in the heavens, such as the spaces between two stars, and the diameters of the sun, moon, and planets; and by the help of which, the *apparent magnitude* of all objects viewed through telescopes may be measured with great exactness.

There are various descriptions of these instruments, constructed with different substances and in various forms, of which the following constitute the principal variety: the *Wire Micrometer*—the *Snyder's-line Micrometer*—the *Polymetric Reticle*—*Divided Object-glass Micrometer*—*Divided Eyeglass Micrometer*—*Ramsden's Catoptric Micrometer*—*Rochen's Crystal Micrometer*—*Maskekyne's Prismatic Micrometer*—*Brewster's Micro-metrical Telescope*—*Sir W. Herschel's Lamp Micrometer*—*Cavalle's Mother-of-Pearl Micrometer*, and several others; but instead of attempting even a general description of these instruments, I shall confine myself merely to a very brief description of *Cavallo's Micrometer*, as its construction will be easily understood by the general reader, as it is one of the most simple of these instruments, and is so cheap as to be procured for a few shillings, while some of the instruments now mentioned are so expensive as to cost nearly as much as a tolerably good telescope.\*

This micrometer consists of a thin and narrow slip of mother-of-pearl finely divided, which is placed in the focus of the eyeglass of a telescope, just where the image of the object is formed; and it may be applied either to a reflecting or a refracting telescope, provided the eyeglass be a convex lens. It is about the twentieth part of an inch broad, and of the thickness of common writing paper, divided into equal parts by parallel lines, every fifth and tenth of which is a little longer than the rest. The simplest way of fixing it is to stick it upon the diaphragm, which generally stands within the tube, and in the focus of the eyeglass. When thus fixed, if you look through the eyeglass, the divisions of the micrometrical scale will appear very distinct, unless the diaphragm is not exactly in the focus of the eyeglass, in which case it must be moved to the proper place; or the micrometer may be placed exactly in the focus of the eyelens by the interposition of a circular piece of paper, card, or by means of wax. If a person should not like to see always

the micrometer in the field of the telescope, then the micrometrical scale, instead of being fixed to the diaphragm, may be fitted to a circular perforated plate of brass, of wood, or even of paper, which may be occasionally placed upon the said diaphragm. One of these micrometers, in my possession, which contains 600 divisions in an inch, is fitted up in a separate eyetube, with a glass peculiar to itself, which slides into the eyepiece of the telescope when its own proper glass is taken out.

To ascertain the Value of the Divisions of this Micrometer.—Direct the telescope to the sun, and observe how many divisions of the micrometer measure its diameter exactly; then take out of the Nautical Almanac the diameter of the sun for the day on which the observation is made; divide it by the above-mentioned number of divisions, and the quotient is the value of one division of the micrometer. Thus, suppose that 26 $\frac{1}{2}$  divisions of the micrometer measure the diameter of the sun, and that the Nautical Almanac gives for the measure of the same diameter 31' 22", or 1822": divide 1822 by 26.5, and the quotient is 71", or 1' 11", which is the value of one division of the micrometer, the double of which is the value of two divisions, and so on. The value of the divisions may likewise be ascertained by the passage of an equatorial star over a certain number of divisions in a certain time. The stars best situated for this purpose are such as the following:  $\delta$  in the Whale, R. A. 37° 31 $\frac{1}{2}$ ", Dec. 37' 50" S.;  $\zeta$  in Orion, R. A. 80° 11' 42", Dec. 28' 49" S.;  $\nu$  in the Lion, R. A. 171° 25' 21", Dec. 23' 23" N.;  $\eta$  in Virgo, R. A. 132° 10', Dec. 33' 27" N. But the following is the most easy and accurate method of determining the value of the divisions.

Mark upon a wall or other place the length of six inches, which may be done by making two dots or lines six inches asunder, or by fixing a six inch ruler upon a stand. Then place the telescope before it, so that the ruler, or six inch length may be at right angles with the direction of the telescope, and just 57 feet 3 $\frac{1}{2}$  inches distant from the object-glass of the telescope; this done, look through the telescope at the ruler, or other extension of six inches, and observe how many divisions of the micrometer are equal to it, and that same number of divisions is equal to half a degree, or 30'; and this is all that is necessary for the required determination; the reason of which is, because an extension of six inches subtends an angle of 30' at the distance of 57 feet 3 $\frac{1}{2}$  inches, as may be easily calculated from the rules of Plane Trigonometry.

\* A particular description of the micrometers here enumerated, and several others, will be found in Dr. Pearson's "Introduction to Practical Astronomy," vol. ii.

Fig. 85 exhibits this micrometer scale, but shows it four times larger than the real size of one which was adapted to a three feet achromatic telescope magnifying 84 times. The divisions upon it are the 200ths of an inch, which reach from one edge of the scale to about the middle of it, excepting every fifth and tenth division, which are longer. Two divisions of this scale are very nearly equal to one minute; and as a quarter of one of these divisions may be distinguished by estimation, therefore an angle of one-eighth of a minute, or of  $7\frac{1}{2}''$ , may be measured with it. When a telescope magnifies more, the divisions of the micrometer must be more minute. When the focus of the eyeglass of the telescope is shorter than half an inch, the micrometer may be divided with the 500ths of an inch; by means of which, and the telescope magnifying about 200 times, one may easily and accurately measure an angle smaller than half a second. On the other hand, when the telescope does not magnify above 30 times, the divisions need not be so minute. In one of Dollond's pocket telescopes, which, when drawn out for use, is only 14 inches long, a micrometer with the hundredths of an inch is quite sufficient, and one of its divisions is equal to little less than three minutes, so that an angle of a minute may be measured by it. Supposing  $11\frac{1}{2}''$  of those divisions equal to  $30'$ , or 23 to a degree, any other angle measured by any other number of divisions is determined by proportion. Thus, suppose the diameter of the sun, seen through the same telescope, be found equal to 12 divisions, say, as  $11\frac{1}{2}''$  divisions are to 30 minutes, so are 12 divisions to  $(\frac{12 \times 30}{11.5}) 31.3$ , which is the required diameter of the sun.

*Practical Uses of this Micrometer.*—This micrometer may be applied to the following purposes; 1. For measuring the apparent diameters of the sun, moon, and planets. 2. For measuring the apparent distances of the satellites from their primaries. 3. For measuring the cusps of the moon in eclipses. 4. For measuring the apparent distances between two contiguous stars—between a star and a planet—between a star and the moon—or between a comet and the contiguous stars, so as to determine its path. 5. For finding the difference of declination of contiguous stars, when they have nearly the same right ascension. 6. For measuring the small elevations or depressions of objects above and below the horizon. 7. For measuring the proportional parts of buildings, and other objects in perspective drawing. 8. For ascertaining whether a ship at sea, or any moving object, is coming nearer or going farther off; for if the angle subtended by the object appears to increase, it shows that the object is coming nearer, and if the angle appears to decrease, it indicates that the object is receding from us. 9. For ascertaining the real distances of objects of known extension, and hence to measure heights, depths, and horizontal distances. 10. For measuring the real extensions of objects when their distances are known. 11. For measuring the distance and size of an object when neither of them is known.

When the micrometer is adapted to those telescopes which have four glasses in the eyetube, and when the eyetube only is used, it may be applied to the following purposes: 1. For measuring the real or lineal dimensions of small objects, instead of the angles; for if the tube be unscrewed from the rest of the telescope, and applied to small objects, it will serve for a microscope, having a considerable magnifying power, as we have already shown (p. 97); and the micrometer, in that case, will

measure the lineal dimensions of the object, as the diameter of a hair, the length of a flea, or the limbs of an insect. In order to find the value of the divisions for this purpose, we need only apply a ruler, divided into tenths of an inch, to the end of the tube, and looking through the tube, observe how many divisions of the micrometer measure one-tenth of

Fig. 85.

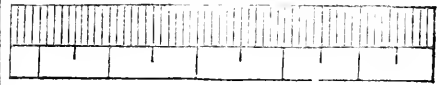

an inch on the ruler, which will give the required value. Thus, if 30 divisions are equal to  $\frac{1}{10}$ th of an inch, 300 of them must be equal to the 300th part of an inch. 2. For measuring the magnifying power of other telescopes. This is done by measuring the diameter of the pencil of light at the eye-end of the telescope in question; for, if we divide the diameter of the object-lens by the diameter of this pencil of light, the quotient will express how many times that telescope magnifies in diameter. Thus, suppose that 300 divisions of the micrometer are equal to the apparent extension of one inch—that the pencil of light is measured by four of these divisions—and that the diameter of the object-lens measures one inch and two tenths: Multiply 1.2 by 300, and the product 360, divided by 4, gives 90 for the magnifying power of the telescope.

*Problems which may be solved by this Micrometer.*

—I. The angle—not exceeding one degree—which is subtended by an extension of one foot, being given, to find its distance from the place of observation: Rule 1. If the angle be expressed in minutes, say as the given angle is to 60, so is 687.55 to a fourth proportional, which gives the answer in inches. 2. If the angle be expressed in seconds, say, as the given angle is to 3600, so is 687.55 to a fourth proportional, which expresses the answer in inches. 3. If the angle be expressed in minutes and seconds, turn it all into seconds, proceed as above. Example: At what distance is a globe of one foot in diameter when it subtends an angle of two seconds?  $2 : 3600 : : 687.55 : \frac{3600 \times 687.55}{2} = 1237596$  inches, or 103132 $\frac{1}{2}$  feet—the answer required. II. The angle which is subtended by any known extension being given, to find its distance from the place of observation: Rule: Proceed as if the extension were of one foot, by Problem I, and call the answer B; then, if the extension in question be expressed in inches, say as 12 inches are to that extension, so is B to a fourth proportional, which is the answer in inches. But if the extension in question be expressed in feet, then we need only multiply it by B, and the product is the answer in inches. Example: At what distance is a man six feet high when he appears to subtend an angle of  $30''$ ? By Problem I, if the man were one foot high the distance would be 82506 inches; but as he is six feet high, therefore multiply 82506 by 6, and the product is the required distance, namely, 495036 inches, or 41253 feet.

For greater convenience, especially in travelling, when one has not the opportunity of making such calculations, the two following tables have been calculated, the first of which shows the distance answering to any angle from one minute to one degree, which is subtended by a man whose height is considered an extension of six feet, because at a mean, such is the height of a man when

dressed with hat and shoes on. These tables may be transcribed on a card, and may be kept always ready with a pocket telescope furnished with a micrometer. Their use is to ascertain distances without any calculations; and they are calculated only to minutes, because with a pocket telescope and micrometer it is not possible to measure an angle more accurately than to a minute. Thus, if we want to measure the extension of a street, let a foot ruler be placed at the end of the street; measure the angular appearance of it, which suppose to be 36', and in the table we have the required distance against 36', which is 95½ feet. Thus, also, a man who appears to be 49' high at the distance of 421 feet. Again: Suppose the trunk of a tree, which is known to be three feet in diameter, be observed to subtend an angle of

9½'. Take the number answering to 9' out of the table, namely 382, and subtract from it a proportional part for the half minute, namely 19.1, which, subtracted from 382, leaves 362.9. This multiplied by 3, the diameter of the tree, produces 1087.7 feet—the distance from the object-end of the telescope.

In this way the distance of a considerably remote object, as a town or building at ten or twelve miles' distance, may be very nearly determined, provided we have the lineal dimensions of a house or other object that stands at right angles to the line of vision. The breadth of a river, of an arm of the sea, or the distance of a lighthouse, whose elevation above the sea or any other point is known, may likewise, in this manner be easily determined.

Angles subtended by an extension of one foot at different distances.				Angles subtended by an extension of six feet at different distances.			
Angles in minutes.	Distances in feet.	Angles in minutes.	Distances in feet.	Angles in minutes.	Distances in feet.	Angles in minutes.	Distances in feet.
1	3438	31	110.9	1	20626.8	31	665.4
2	1719	32	107.4	2	10313	32	644.5
3	1146	33	104.2	3	6875.4	33	625
4	859.4	34	101.1	4	5156.5	34	606.6
5	678.5	35	98.2	5	4125.2	35	589.3
6	572.9	36	95.5	6	3437.7	36	572.9
7	491.1	37	92.9	7	2946.6	37	557.5
8	429.7	38	90.1	8	2578.2	38	542.8
9	382	39	88.1	9	2291.8	39	528.9
10	343.7	40	85.9	10	2062.6	40	515.6
11	312.5	41	83.8	11	1875.2	41	503.1
12	286.5	42	81.8	12	1718.8	42	491.7
13	264.4	43	79.9	13	1586.7	43	479.7
14	245.5	44	78.1	14	1473.3	44	468.3
15	229.2	45	76.4	15	1375	45	458.4
16	214.8	46	74.7	16	1298.1	46	448.4
17	202.2	47	73.1	17	1231.3	47	438.9
18	191	48	71.6	18	1145.9	48	429.7
19	181	49	70.1	19	1085.6	49	421
20	171.8	50	68.7	20	1031.4	50	412.5
21	162.7	51	67.4	21	982.2	51	404.4
22	156.2	52	66.1	22	937.6	52	396.7
23	149.4	53	64.8	23	896.8	53	389.2
24	143.2	54	63.6	24	859.4	54	381.9
25	137.5	55	62.5	25	825	55	375
26	132.2	56	61.4	26	793.3	56	368.3
27	127.3	57	60.3	27	763.9	57	361.9
28	122.7	58	59.1	28	736.6	58	355.6
29	118.5	59	58.2	29	711.3	59	349.6
30	114.6	60	57.3	30	687.5	60	343.7

## CHAPTER II.

### ON THE EQUATORIAL TELESCOPE, OR PORTABLE OBSERVATORY.

The equatorial instrument is intended to answer a number of useful purposes in Practical Astronomy, independently of any particular observatory. Beside answering the general purpose of a quadrant, a transit instrument, a theodolite, and an azimuth instrument, it is almost the only instrument adapted for viewing the stars and planets in the day-time, and for following them in their apparent diurnal motions. It may be made use of in any steady room or place, and performs most of the useful problems in astronomical science.

The basis of all equatorial instruments is a revolving axis, placed parallel to the axis of the earth, by which an attached telescope is made to follow a star or other celestial body in the arc of

its diurnal revolution, without the trouble of repeated adjustments for changes of elevation, which quadrants and circles with vertical and horizontal axes require. Such an instrument is not only convenient for many useful and interesting purposes in celestial observations, but is essentially requisite in certain cases, particularly in examining and measuring the relative positions of two contiguous bodies, or in determining the diameters of the planets, when the spider's-line micrometer is used.

Christopher Scheiner is supposed to have been the first astronomer who, in the year 1620, made use of a polar axis, but without any appendage of graduated circles. It was not, however, until

the middle of the last century that any instruments of this description, worthy of the name, were attempted to be constructed. In 1741, Mr. Henry Hindley, a clockmaker in York, added to the polar axis an equatorial plate, a quadrant of altitude, and declination semicircle; but when this piece of mechanism was sent to London for sale in 1748, it remained unsold for the space of 13 years. Mr. Short, the optician, published in the Philosophical Transactions for 1759 a "description of an equatorial telescope," which was of the reflecting kind, and was mounted over a combination of circles and semicircles, which were strong enough to support a tube, and a speculum of the Gregorian construction 18 inches in focal length. This instrument consisted of a somewhat cumbersome and expensive piece of machinery, a representation of which may be seen in vol. iii. of Martin's "*Philosophia Britannica*, or System of the Newtonian Philosophy." Various modifications of this instrument have since been made by Nairne, Dollond, Ramsden, Troughton, and other artists; but even at the present period it has never come into very general use, though it is one of the most pleasant and useful instruments connected with astronomical observations.

As many of these instruments are somewhat complicated and very expensive, I shall direct the attention of the reader solely to one which I consider as the most simple, which may be purchased at a moderate expense, and is sufficiently accurate for general observations.

The instrument consists of the following parts: A horizontal circle, *E F* (fig. 86), divided into

Fig. 86.

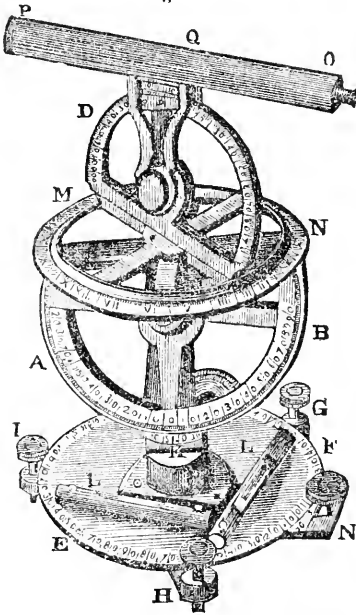

four quadrants of 90 degrees each. There is a fixed nonius at *N*; and the circle is capable of being turned round on an axis. In the center of the horizontal circle is fixed a strong upright pillar, which supports the center of a vertical semicircle, *A B*, divided into two quadrants of 90 degrees each. This is called the *semicircle of altitude*, and may, at any time, serve the purpose of

a quadrant in measuring either altitudes or depressions. It has a nonius plate at *K*. At right angles to the plane of this semicircle, the *equatorial circle*, *M N*, is firmly fixed. It represents the equator, and is divided into twice twelve hours, every hour being divided into twelve parts of five minutes each. Upon the equatorial circle moves another circle, with a chamfered edge, carrying a nonius, by which the divisions on the equatorial may be read off to single minutes; and at right angles to this movable circle is fixed the *semicircle of declination*, *D*, divided into two quadrants of 90 degrees each. The telescope, *P O*, is surmounted above this circle, and is fixed to an index movable on the semicircle of declination, and carries a nonius opposite to *Q*. The telescope is furnished with two or three Huygenian eyepieces and likewise with a diagonal eyepiece for viewing objects near the zenith. Lastly, there are two spirit levels fixed on the horizontal circle at right angles to each other, by means of which this circle is made perfectly level when observations are to be made.

*To adjust the Equatorial for Observations.*—Set the instrument on a firm support; then, to adjust the levels and the horizontal circle, turn the horizontal circle until the beginning *O* of the divisions coincides with the middle stroke of the nonius, or near it. In this situation, one of the levels will be found to lie either in a right line joining the two footscrews which are nearest the nonius, or else parallel to such a right line. By means of the last two screws, cause the bubble in the level to become stationary in the middle of the glass; then turn the horizontal circle half round by bringing the other *O* to the nonius; and if the bubble remains in the middle as before, the level is well adjusted; if it does not, correct the position of the level by turning one or both of the screws which pass through its ends until the bubble has moved half the distance it ought to come to reach the middle, and cause it to move the other half by turning the foot-screws already mentioned; return the horizontal circle to its first position, and if the adjustments have been well made, the bubble will remain in the middle; if otherwise, the process must be repeated until it bears this proof of its accuracy; then turn the horizontal circle until  $90^\circ$  stands opposite to the nonius; and by the foot-screw immediately opposite the other  $90^\circ$ , cause the bubble of the same level to stand in the middle of the glass; lastly, by its own proper screws set the other level so that its bubble may occupy the middle of its glass.

*To adjust the Line of Sight.*—Set the nonius on the declination semicircle at *O*, the nonius on the horary circle at *VI*, and the nonius on the semicircle of altitude at  $90^\circ$ ; look through the telescope toward some part of the horizon where there is a diversity of remote objects; level the horizontal circle, and then observe what object appears in the center of the cross-wires, or in the center of the field of view if there be no wires; reverse the semicircle of altitude so that the other  $90^\circ$  may apply to the nonius, taking care, at the same time, that the other three noniuses continue at the same parts of their respective graduations as before. If the remote object continues to be seen on the center of the cross-wires, the line of sight is truly adjusted.

*To find the Correction to be applied to Observations by the Semicircle of Altitude.*—Set the nonius on the declination semicircle to *O*, and the nonius on the horary circle to *XII*; direct the telescope to any fixed and distant object by moving the horizontal circle and semicircle of altitude, and

nothing else; note the degree and minute of altitude or depression; reverse the declination semicircle by directing the nonius on the horary circle to the opposite XII; direct the telescope again to the same object, by means of the horizontal circle and semicircle of altitude, as before. If its altitude or depression be the same as was observed in the other position, no correction will be required; but if otherwise, half the difference of the two angles is the correction to be added to all observations made with that quadrant, or half of the semicircle which shows the least angle, or to be subtracted from all the observations made with the other quadrant, or half of the semicircle. When the levels and other adjustments are once truly made, they will be preserved in order for a length of time, if not deranged by violence; and the correction to be applied to the semicircle of altitude is a constant quantity.

*Description of the Nonius.*—The nonius—sometimes called the *Vernier*—is a name given to a device for subdividing the arcs of quadrants and other astronomical instruments. It depends on the simple circumstance that if any line be divided into equal parts, the length of each part will be greater the fewer the divisions; and contrariwise, it will be less in proportion as those divisions are more numerous. Thus, in the equatorial now described, the distance between the two extreme strokes on the nonius is exactly equal to eleven degrees on the limb, only that it is divided into twelve equal parts. Each of these last parts will therefore be shorter than the *degree* on the limb in the proportion of 11 to 12, that is to say, it will be  $\frac{1}{12}$ th part, or five minutes shorter; consequently, if the middle stroke be set precisely opposite to any degree, the relative positions of the nonius and the limb must be altered five minutes of a degree before either of the two adjacent strokes next the middle on the nonius can be brought to coincide with the nearest stroke of a degree; and so likewise the second stroke on the nonius will require a change of ten minutes, the third of fifteen, and so on to thirty, when the middle line of the nonius will be seen to be equidistant between two of the strokes on the limb; after which, the lines on the opposite side of the nonius will coincide in succession with the strokes on the limb. It is clear from this that whenever the middle stroke of the nonius does not stand precisely opposite to any degree, the odd minutes, or distance between it and the degree immediately preceding, may be known by the *number* of the stroke marked on the nonius, which coincides with any of the strokes on the limb.\* In some instruments the nonius-plate has its divisions fewer than the number of parts on the limb to which it is equal; but when once a clear idea of the principle of any nonius is obtained, it will be easy to transfer it to any other mode in which this instrument is contrived.

*To find by this Equatorial the MERIDIAN LINE, and the TIME, FROM ONE OBSERVATION OF THE SUN.*—In order to this, it is requisite that the sun's declination and the latitude of the place be known. The declination of the sun may be found for every day in the Nautical Almanac, or any other astronomical ephemeris; and the latitude of the place may be found by means of the semicircle of altitude, when the telescope is directed to the sun or a known fixed star. It is likewise requisite to make the observation when the azimuth and altitude of the sun alter quickly, and this is generally the case the further that luminary is from the

meridian; therefore at the distance of three or four hours either before or afternoon (in summer), adjust the horizontal circle; set the semicircle of altitude so that its nonius may stand at the colatitude of the place; lay the plane of the last-mentioned semicircle in the meridian by estimation, its 0 being directed toward the depressed pole; place the nonius of the declination semicircle to the declination, whether north or south; then direct the telescope toward the sun, partly by moving the declination semicircle on the axis of the equatorial circle, and partly by moving the horizontal circle on its own axis. There is but one position of these which will admit of the sun being seen in the middle of the field of view. When this position is obtained, the nonius on the equatorial circle shows the *apparent time, and the circle of altitude is in the plane of the meridian.* When this position is ascertained, the meridian may be settled by a landmark at a distance.

With an equatorial instrument nearly similar to that now described, I formerly made a series of "*day observations on the celestial bodies,*" which were originally published in vol. xxxvi, of "*Nicholson's Journal of Natural Philosophy,*" and which occupy twenty pages of that journal. Some of these observations I shall lay before the reader, after having explained the manner in which they are made.

The instrument was made by Messrs. W. and S. Jones, opticians, Holborn, London. The telescope which originally accompanied the instrument was an achromatic refractor, its object-glass being  $8\frac{1}{2}$  inches focal distance, and one inch in diameter. This telescope, not admitting sufficiently high magnifying powers for the observations intended, was afterward thrown aside for another telescope having an object-glass 20 inches focal length and  $1\frac{3}{4}$  inches in diameter, which was attached to the equatorial machinery in place of the small telescope. It was furnished with magnifying powers of 15, 30, 45, 60, and 100 times. The instrument was placed on a firm pedestal about three feet high. The feet of this pedestal had short iron pikes, which slipped into corresponding holes in the floor of the apartment adjacent to a south window, so that when the direction of the meridian was found, and the circles properly adjusted, the instrument was in no danger of being shifted from this position. Though this instrument generally stood fronting the southern part of the heavens, yet the equatorial part along with the telescope, could occasionally be removed to another position fronting the north and north-west, for observing the stars in those quarters.

*Manner of observing Stars and Planets in the Day-time by the Equatorial.*—Before such observation can be made, the semicircle of altitude must be placed in the meridian, and the degree and minute pointed out by the nonius on the horizontal circle, when in this position, noted down in a book, so that it may be placed again in the same position, should any derangement afterward happen. The semicircle of altitude must be set to the colatitude of the place, that is, to what the latitude wants of  $90^\circ$ . Suppose the latitude of the place of observation be  $52^\circ 30'$  north, this latitude subtracted from  $90^\circ$  leaves  $37^\circ 30'$  for the colatitude, and therefore the semicircle of altitude on which the equatorial circle is fixed, must be elevated to  $37^\circ 30'$ , and then the equatorial circle on the instrument coincides with the equator in the heavens. Lastly, the telescope must be adjusted on the declination semicircle so as exactly to correspond with the declination of the heavenly body to be viewed. If the body is in the equa-

\* Adams's Introduction to Practical Astronomy.

tor, the telescope is set by the index at 0 on the semicircle of declination, or at the middle point between the two quadrants, and then, when the telescope along with the semicircle of declination, is moved from right to left, or the contrary, it describes an arc of the equator. If the declination of the body be north, the telescope is elevated to the northern division of the semicircle; if south, to the southern part of it.

These adjustments being made, take the difference between the right ascension of the sun and the body to be observed, and if the right ascension of the body be greater than that of the sun, subtract the difference from the time of observation; if not, add to the time of observation.\* The remainder in one case, or the sum in the other, will be the hour and minute to which the nonius on the equatorial circle is to be set; which being done, the telescope will point to the star or planet to whose declination the instrument is adjusted. When the heavenly body is thus found, it may be followed, in its diurnal course, for hours, or as long as it remains above the horizon; for as the diurnal motion of a star is parallel to the equator, the motion of the telescope on the equatorial circle will always be in the star's diurnal arc; and should it have left the field of the telescope for any considerable time, it may be again recovered by moving the telescope onward according to the time which elapsed since it was visible in the field of view. We may illustrate what has been now stated by an example or two: Suppose on the 30th of April, 1841, at one o'clock, p. m., we wished to see the star *Aldebaran*: the right ascension of this star is 4h 27m., and the sun's right ascension for that day at noon, as found in "White's Ephemeris" or the "Nautical Almanac," is 2h. 30m.; subtract this last number from 4h. 27m., and the remainder 1h. 57m., shows that the star comes to the meridian on that day at 57 minutes past 1 o'clock p. m.; and as the time of observation is 1 p. m., the nonius which moves on the equatorial circle must be set to three minutes past XI, as the star is at that hour 57 minutes from the meridian. The declination of *Aldebaran* is  $16^{\circ} 11'$  north, to which point on the semicircle of declination the telescope must be adjusted, and then the star will be visible in the field of view. Again: suppose we wished to observe the planet *Venus* on 1st of Jan., 1842, at 12 o'clock noon: the sun's right ascension on that day is 15h. 46m., and that of *Venus* 17h. 41m., from which the sun's right ascension being subtracted, the remainder is 22h. 55m., or 55 minutes past 10, a. m. Here, as the right ascension of *Venus* is too small to have the sun's right ascension taken from it, we borrow 24 hours, and reckon the remainder from XII, at noon. As the planet at 12 at noon is one hour and five minutes past the meridian, the nonius on the equatorial circle must be set to that point, and the telescope adjusted to  $23^{\circ} 6'$  of south declination, which is the declination of *Venus* for that day, when this planet will appear in the field of view.

#### OBSERVATIONS ON THE FIXED STARS AND PLANETS, MADE IN THE DAY-TIME BY THE EQUATORIAL.

For the purpose of illustrating the descriptions now given, and for affording some information, respecting celestial day observations, I shall select

a few of the observations above alluded to, which I formerly published in Nicholson's Journal, along with a few others which have been since made. These observations were made with a view to determine the following particulars: 1. What stars and planets may be conveniently seen in the daytime when the sun is above the horizon? 2. What degrees of magnifying power are requisite for distinguishing them? 3. How near their conjunction with the sun they may be seen? and, 4. Whether the diminution of the aperture of the object-glass of the telescope, or the increase of magnifying power, conduces most to render a star or a planet visible in daylight. Having never seen such observations recorded in books of astronomy or in scientific journals, I was induced to continue them, almost every clear day, for nearly a year, in order to determine the points now specified. Some of the results are stated in the following pages.

*Observations on Fixed Stars of the first Magnitude.*—April 23, 1813, at 10h. 16m., a. m., the sun being  $5\frac{1}{2}$  hours above the horizon, saw the star *Vega*, or  $\alpha$  *Lyrae*, very distinctly with a power of 30 times. Having contracted the aperture of the object-glass to 9-10ths of an inch, saw it on a darker ground, but not more plainly than before. Having contracted the aperture still further to half an inch, I perceived the star, but not so distinctly as before. The sky being very clear, and the star in a quarter of the heavens nearly opposite to the sun, I diminished the magnifying power to 15, and could still perceive the star, but indistinctly; it was just perceptible. August 23, at 9h. 12m., p. m. saw the star *Capella* or  $\alpha$  *Aurige*, with a power of 60, and immediately afterward with a power of 30, the aperture undiminished. With this last power it appeared extremely distinct, but not so brilliant and splendid as with the former power. Having diminished the aperture to 9-10ths of an inch, it appeared on a darker ground, though in the former case it was equally perceptible. A few minutes afterward, could distinguish it with a power of 15, the aperture being contracted to half an inch. It appeared very small; it was with difficulty the eye could fix upon it in the field of the telescope; but when it was once perceived, its motion across the field of view could be readily followed. It could not be perceived when the diminished aperture was removed. The sun was then shining in meridian splendor.

August 10th, 9h. 30m., a. m., saw the star *Sirius* with a power of 60, the aperture contracted to 9-10ths of an inch; saw it likewise when the aperture was diminished to half an inch, but not so distinctly as through the aperture of 9-10ths of an inch. Having put on a power of 30, could distinguish it distinctly enough through each of the former apertures, and likewise when they were removed, but somewhat more distinctly with the apertures of 9-10ths and a half inch than without them. At this time the star was 2h. 42m. in time of right ascension west of the sun, having an elevation above the horizon of about  $17^{\circ} 10'$ , the sun shining bright, and the sky very much enlightened in that quarter of the heavens where the star appeared. There was also a considerable undulation of the air, which is generally the case in the hot mornings of summer, which renders a star more difficult to be perceived than in the afternoon, especially when it is viewed at a low altitude. June 4th, 1h. 30m., p. m., saw *Sirius* with a power of 30 with great distinctness, the aperture not contracted. The star was then within 1h. 50m. in time of right ascension east from the sun. August 24th, 9h. 5m., a. m., saw

\*Or find the sun's right ascension for the given day; subtract this from the star or planet's right ascension, and the remainder is the approximate time of the star's coming to the meridian. The difference between this time and the time of observation will then determine the point to which the telescope is to be directed.

the star *Procyon*,  $\alpha$  *Canis Minoris*, distinctly with a power of 60, the aperture not contracted. When diminished to 9-10ths of an inch, it appeared rather more distinct, as the ground on which it was seen was darker. With a power of 30, and the aperture contracted to 9-10ths of an inch, could perceive it, but somewhat indistinctly. When the equatorial motion was performed in order to keep it in the field of view, it was some time before the eye could again fix upon it. When the aperture was diminished to half an inch, it could not be perceived. Saw it when both the apertures were removed, but rather more distinctly with the aperture of 9-10ths of an inch. The difference in the result of this observation from that of *Capella* above stated was owing to the star's proximity to the sun, and the consequent illumination of the sky in that quarter where it appeared. Its difference in right ascension from that of the sun was then about 2h. 5m. of time, and its difference of declination about  $4^{\circ} 50'$ .\* This star may be considered as one of those which rank between the first and second magnitudes.

Similar observations to the above were made and frequently repeated on the stars *Rigel*, *Aldebaran*, *Betelgeuse*,  $\gamma$  *Leonis*, and other stars of the first magnitude, which gave nearly the same results. The stars *Altares* and *Fomalhaut* are not so easily distinguished, on account of their great southern declination, and consequent low elevation above the horizon. The following observation on *Arcturus* may be added. June 3d, observed *Arcturus* very distinctly a little before seven in the evening,—the sun being about 1h. 40m. above the horizon, and shining bright—with a power of 15, the aperture not contracted. It appeared very small, but distinct. This star is easily distinguishable at any time of the day with a power of 30.

*Observations on Stars of the Second Magnitude.*—May 5, 1813, at 6h., p. m., the sun being an hour and three-quarters above the horizon, saw *Alphard*, or  $\alpha$  *Hydræ*, a star of the second magnitude, with a power of 60, the aperture diminished to 9-10ths of an inch. A few minutes afterward could perceive it, but indistinctly, with a power of 30, the aperture contracted as above. It could not be seen very distinctly with this power until about half an hour before sunset. It was then seen rather more distinctly when the aperture was contracted than without the contraction. May 7th, saw the star *Deneb*, or  $\epsilon$  *Leonis*, distinctly with a power of 60, about an hour and a half before sunset. August 20th, saw *Ras Alhague*, or  $\alpha$  *Ophiuchi*, at 4h. 40m., p. m., with a power of 100, the sun being nearly three hours above the horizon, and shining bright. Perceived it about an hour afterward with a power of 60, with the aperture contracted to 9-10ths of an inch, and also when this contraction was removed. The star was seen nearly as distinctly in the last case as in the first. August 27, 5h., p. m., the same star appeared quite distinct with a power of 60, the aperture not contracted. It did not appear more distinct when the aperture was contracted to

\* The right ascensions, declinations, longitudes, &c., stated in these memoranda, which were noted at the time of observation, are only approximations to the truth; perfect accuracy in these respects being of no importance in such observations. They are, however, in general, within a minute or two of the truth. The times of the observations, too, are noted in reference, not to the astronomical, but to the civil day. The astronomical day commences at 12 noon, and the hours are reckoned, without interruption, to the following noon. The civil day commences at 12 midnight

9-10ths of an inch. The sun was then more than two hours above the horizon. August 28th, saw the star *Pollux*, or  $\zeta$  *Gemini*, two hours after sunrise, with a power of 60, aperture undiminished. November 12th, 1h. 30m., p. m., saw the star *Allair*, or  $\alpha$  *Aquila*, with an  $8\frac{1}{2}$  inch telescope, one inch aperture, carrying a power of 45, the aperture not contracted. Having contracted the aperture a little, it appeared somewhat less distinct. This star is reckoned by some to belong to the class of stars of the first magnitude, but in White's "Ephemeris" and other almanacs it is generally marked as being of the second magnitude. It forms a kind of medium between stars of the first and second magnitude.

Similar observations, giving the same results, were made on the stars *Bellatrix*, *Orion's Giraffe*,  $\alpha$  *Andromedæ*,  $\alpha$  *Pegasi*, *Alioth*, *Benetnasch*, *North Crown*, or  $\alpha$  *Coronæ Borealis*, and various other stars of the same magnitude.

From the above and several hundreds of similar observations, the following conclusions are deduced:

1. That a magnifying power of 30 times is sufficient for distinguishing a fixed star of the first magnitude, even at noonday, at any season of the year, provided it have a moderate degree of elevation above the horizon, and be not within  $30^{\circ}$  or  $40^{\circ}$  of the Sun's body; also, that by a magnifying power of 15, a star of this class may be distinguished when the sun is not more than an hour and a half above the horizon; but, in every case, higher powers are to be preferred. Powers of 45 or 60, particularly the last, were found to answer best in most cases, as with such powers the eye could fix on the star with ease as soon as it entered the field of the telescope.

2. That most of the stars of the second magnitude may be seen with a power of 60 when the sun is not much more than two hours above the horizon; and, at any time of the day, the brightest stars of this class may be seen with a power of 100 when the sky is serene, and the star not too near the quarter in which the sun appears.

3. That, in every instance, an increase of magnifying power has the principal effect in rendering a star easily perceptible; that diminution of aperture, in most cases, produces a very slight effect—in some cases none at all; and, when the aperture is contracted beyond a certain limit, it produces a hurtful effect. The cases in which a moderate contraction is useful are the two following: 1. When the star appears in a bright part of the sky, not far from that quarter in which the sun appears. 2. When an object-glass of a large aperture and a small degree of magnifying power is used. In almost every instance, the contraction of the object-glass of the  $8\frac{1}{2}$  inch telescope with a power of 45 had a hurtful effect; but when the 20 inch telescope carried a power of only 15, the contraction served to render the object more perceptible.

#### OBSERVATIONS ON THE PLANETS MADE IN THE DAY-TIME.

Some of the planets are not so easily distinguished in the day-time as the fixed stars of the first magnitude. The one which is most easily distinguished at all times is the planet *Venus*.

1. *Observations on Venus.*—My observations on this planet commenced about the end of August, 1812, about three or four weeks after its inferior conjunction. About that period, between ten and eleven in the forenoon, with a power of 45, it appeared as a beautiful crescent, quite distinct and well-defined, with a luster similar to that of the



moon about sunset, but of a whiter color. The view of its surface and phase was fully more distinct and satisfactory than what is obtained in the evening after sunset; for, being at a high elevation, the undulation near the horizon did not affect the distinctness of vision. The planet was then very distinctly seen with a power of seven times, when it appeared like a star of the first or second magnitude. I traced the variation of its phases almost every clear day until the month of May, 1813. As at that time it was not far from its superior conjunction with the sun, I wished to ascertain how near its conjunction with that luminary it might be seen, and particularly whether it might not be possible, in certain cases, to see it at the moment of its conjunction.

The expressions of all astronomical writers previous to this period, when describing the phases of Venus, either directly assert, or at least imply, that it is impossible to see that planet, in any instance, at the time of its superior conjunction. This is the language of Dr. Long, Dr. Gregory, Dr. Brewster, Ferguson, Adams, B. Martin, and most other writers on the science of Astronomy. How far such language is correct will appear from the following observations and remarks.

April 24, 1813, 10h. 50m., A. M., observed Venus with a power of 30, the aperture not contracted. She was then about 31 minutes of time in right ascension distant from the sun, their difference of declination  $3^{\circ} 59'$ . She appeared distinct and well-defined. With a power of 100, could distinguish her gibbous phase. May 1st, 10h. 20m., A. M., viewed this planet with a power of 60, the aperture not contracted. It appeared distinct. Saw it about the same time with a power of 15, the aperture being contracted to 9-10ths of an inch. Having contracted the aperture to half an inch, saw it more distinctly. When the contracted apertures were removed, the planet could with difficulty be distinguished, on account of the direct rays of the sun striking on the inside of the tube of the telescope. The sun was shining bright, and the planet about  $25'$  of time in R. A. west of his center, their difference of declination being  $3^{\circ} 7'$ . May 7th, 10h., A. M., saw Venus distinctly with a power of 60, the sun shining bright. It was then about  $19'$  of time in R. A., and  $4^{\circ} 27'$  in longitude west of the sun, their difference of declination being  $2^{\circ} 18'$ . I found a diminution of aperture particularly useful when viewing the planet at this time, even when the higher powers were applied. This was the last observation I had an opportunity of making prior to the conjunction of Venus with the sun, which happened on May 25th, at 9h. 3m., A. M. Its geocentric latitude at that time being about  $16'$  south, the planet must have passed almost close by the sun's southern limb. Cloudy weather for nearly a month after the last observation prevented any further views of the planet, when it was in that part of the heavens which was within the range of the instrument. The first day that proved favorable after it had passed the superior conjunction was June 5th. The following is the memorandum of the observation then taken:

June 5th, 9h., A. M., adjusted the equatorial telescope for viewing the planet Venus, but it could not be perceived on account of the direct rays of the sun entering the tube of the telescope. I contrived an apparatus for screening his rays, but could not get it conveniently to move along with the telescope, and therefore determined to wait until past eleven, when the top of the window of the place of observation would intercept the solar rays. At 11h. 20m., A. M., just as the sun had

passed the line of sight from the eye to the top of the window, and his body was eclipsed by it, I was gratified with a tolerably distinct view of the planet, with a power of 60, the aperture being contracted to 9-10ths of an inch. This distinctness increased as the sun retired, until, in two or three minutes, the planet appeared perfectly well-defined. Saw it immediately afterward with a power of 30, the aperture contracted as before. Saw it also quite distinctly with a power of 15; but it could not be distinguished with this power when the contracted aperture was removed. At this time Venus was just  $3^{\circ}$  in longitude, or about  $13'$  in time of R. A. east of the sun's center, and of course only about  $23\frac{3}{4}$ th degrees from his eastern limb; the difference of their declination being  $27'$ , and the planet's latitude  $11'$  north.

Several years afterward I obtained views of this planet when considerably nearer the sun's margin than as stated in the above observation, particularly on the 16th of October, 1819, at which time Venus was seen when only six days and nineteen hours past the time of the superior conjunction. At that time its distance from the sun's eastern limb was only  $1^{\circ} 28' 42''$ . A subsequent observation proved that Venus can be seen when only  $1^{\circ} 27'$  from the sun's margin, which I consider as approximating to the nearest distance from the sun at which this planet is distinctly visible. I shall only state further the two or three following observations.

June 17th, 1813, 10h., A. M., saw Venus with a power of 60, the aperture being contracted to 9-10ths of an inch, the direct rays of the sun *not being intercepted by the top of the window*. The aperture having been farther contracted to half an inch, could perceive her, but not quite so distinctly. When the contractions were removed, she could scarcely be seen. She was then  $3^{\circ} 33'$  in longitude, and nearly 15 minutes in time of R. A. distant from the sun's center. Some fleeces of clouds having moved across the field of view, she was seen remarkably distinct in the interstices, the sun at the same time being partly obscured by them. August 19th, 1h. 10m., P. M., viewed Venus with a magnifying power of 100. Could perceive her surface and gibbous phase almost as distinctly as when the sun is below the horizon. She appeared bright, steady in her light, and well-defined, without that glare and tremulous appearance she exhibits in the evening when near the horizon. She was then nearly on the meridian. On the whole, such a view of this planet is as satisfactory, if not preferable, to those views we obtain with an ordinary telescope in the evening, when it is visible to the naked eye.

All the particulars above stated have been confirmed by many subsequent observations continued throughout a series of years. I shall state only two recent observations, which show that Venus may be seen somewhat nearer the sun than what is deduced from the preceding observations, and at the point of its superior conjunction. March 10th, 1842, observed the planet Venus, then very near the sun, at 19 minutes past 11, A. M. It had passed the point of its superior conjunction with the sun on the 5th of March, at 1h. 13m., P. M. The difference of right ascension between the sun and the planet was then about  $61\frac{1}{2}$  minutes of time, or about  $1^{\circ} 37\frac{1}{2}'$ , and it was only about  $1^{\circ} 21'$  distant from the sun's eastern limb. It appeared quite distinct and well-defined, and might perhaps have been seen on the preceding day, had the observation been then made. The following observation shows that Venus may be seen still nearer the sun than in the preceding

observations, and even at the moment of its superior conjunction. On the 2d of October, 1843, this planet passed the point of its superior conjunction with the sun at 4h. 15m., P.M. At two o'clock, P.M., only two hours before the conjunction, I perceived the planet distinctly, and kept it in view for nearly ten minutes, until some dense clouds intercepted the view. It appeared tolerably distinct and well-defined, though not brilliant, and with a round, full face, and its apparent path was distinctly traced several times across the field of view of the telescope. I perceived it afterward, about half past four, P.M., only a few minutes after it had passed the point of conjunction, on which occasion it appeared less distinct than in the preceding observation, owing to the low altitude of the planet, being then only a few degrees above the horizon. The observations, in this instance, were made, not with an equatorial instrument, which I generally use in such observations, but with a good achromatic telescope of 44 $\frac{1}{2}$  inches focal distance, mounted on a common tripod, with a terrestrial power of 95 times. A conical tube about ten inches long was fixed on the object-end of the telescope, at the extremity of which an aperture 1 $\frac{1}{2}$  inches in diameter was placed, so as to intercept, as much as possible, the direct ingress of the solar rays. The top of the upper sash of the window of the place of observation was likewise so adjusted as to intercept the greater part of the sun's rays from entering the tube of the telescope. The sun's declination at that time was 3° 26' south, and that of Venus 20° 12' south; consequently, the difference of declination was 1° 14'—the distance of Venus from the sun's center; and as the sun's diameter was about 16', Venus was then only 58' from the sun's northern limb, or 6' less than two diameters of the sun.

This is the nearest approximation to the sun at which I have ever beheld this planet, and it demonstrates that Venus may be seen even within a degree of the sun's margin; and it is, perhaps, the nearest position to that luminary in which this planet can be distinctly perceived. It shows that the light reflected from the surface of Venus is far more brilliant than that reflected from the surface of our moon; for no trace of this nocturnal luminary can be perceived, even when at a much greater distance from the sun, nor is there any other celestial body that can be seen within the limit now stated. This is the first observation, so far as my information extends, of Venus having been seen at the time of her superior conjunction.\*

The practical conclusion from this observation is, that at the superior conjunction of this planet, when its distance from the sun's margin is not less than 58', its polar and equatorial diameter may be measured by a micrometer, when it will be determined whether or not Venus be of a spheroidal figure. The Earth, Mars, Jupiter, and Saturn are found to be, not spheres, but spheroids, having their polar shorter than their equatorial diameters. But the true figure of Venus has never yet been ascertained, because it is only at the superior conjunction that she presents a full, enlightened hemisphere, and when both diameters can be measured, except at the time when she transits the sun's disc, which happens only twice in the course of 129 years.†

The following conclusions are deduced from the observations on Venus:

1. That this planet may be seen distinctly, with a moderate degree of magnifying power, at the moment of its superior conjunction with the sun, when its geocentric latitude, either north or south, at the time of conjunction, is not less than 1° 14', or when the planet is about 58' from the

not here omit to mention a very unusual phenomenon that I observed about ten years ago in my darkened room. The window looked toward the west, and the spire of Chichester Cathedral was before it at the distance of 50 or 60 yards. I used very often to divert myself by observing the pleasant manner in which the sun passed behind the spire, and was eclipsed by it for some time; for the image of the sun and of the spire were very large, being made by a lens of 12 feet focal distance; and once, as I observed the occultation of the sun behind the spire, just as the disc disappeared, I saw several small, bright, round bodies or balls running toward the sun from the dark part of the room, even to the distance of 20 inches. I observed their motion was a little irregular, but rectilinear, and seemed accelerated as they approached the sun. These luminous globules appeared also on the other side of the spire, and preceded the sun, running out into the dark room, sometimes more, sometimes less, together, in the same manner as they followed the sun at its occultation. They appeared to be, in general, one-twentieth of an inch in diameter, and therefore must be very large, luminous globes in some part of the heavens, whose light was extinguished by that of the sun, so that they appeared not in open daylight; but whether of the meteor kind, or what sort of bodies they might be, I could not conjecture. Professor Hansteen mentions that, when employed in measuring the zenith distances of the pole-star, he observed a somewhat similar phenomenon, which he described as "a luminous body which passed over the field of the universal telescope; that its motion was neither perfectly equal nor rectilinear, but resembled very much the unequal and somewhat serpentine motion of an ascending roneal; and he concluded that it must have been "a meteor" or "shooting star" descending from the higher regions of the atmosphere. (See Edinburgh Philosophical Journal for April, 1825, No. XXIV.)

In my frequent observations on Venus, to determine the nearest positions to the sun in which that planet could be seen, I had several times an opportunity of witnessing similar phenomena. I was not a little surprised, when searching for the planet, frequently to perceive a body pass across the field of the telescope, apparently of the same size as Venus, though sometimes larger and sometimes smaller, so that I frequently mistook that body for the planet, until its rapid motion undeceived me. In several instances four or five of these bodies appeared to cross the field of view, sometimes in a perpendicular, and at other times in a horizontal direction. They appeared to be luminous bodies, somewhat resembling the appearance of a planet when viewed in the day-time with a moderate magnifying power. Their motion was nearly rectilinear, but sometimes inclined to a waving or serpentine form, and they appeared to move with considerable rapidity—the telescope being furnished with a power of about 70 times. I was for a considerable time at a loss what opinion to form of the nature of these bodies; but, having occasion to continue these observations almost every clear day for nearly a twelvemonth, I had frequent opportunities of viewing this phenomenon in different aspects, and was at length enabled to form an opinion as to the cause of at least some of the appearances which presented themselves. In several instances, the bodies alluded to appeared much larger than usual, and to move with a more rapid velocity; in which case I could plainly perceive that they were nothing else than birds of different sizes, and apparently at different distances, the convex surface of whose bodies, in certain positions, strongly reflected the solar rays. In other instances, when they appeared smaller, their true shape was undistinguishable, by reason of their motion and their distance.

Having inserted a few remarks on this subject in No. xxv, of the Edinburgh Philosophical Journal for July, 1825, particularly in reference to Professor Hansteen's opinion, that article came under the review of M. Serres, sub-prefect of Embrun, in a paper inserted in the *Annales de Chimie* for October, 1825, entitled "Notices regarding fiery meteors seen during the day." (See Edinburgh Philosophical Journal for July, 1826, p. 114.) In the discussion of this subject, M. Serres admits that the light reflected very obliquely from the feathers of a bird is capable of producing an effect similar to that which I have now described, but that "the explanation ought not to be generalised." He remarks, that while observing the sun at the repeating circle, he frequently perceived, even through the colored glass adapted to the eyepiece, large luminous points which traversed the field of the telescope, and which appeared too well-defined not to

\* This observation is inserted in the "Edinburgh Philosophical Journal" for January, 1844.

† The late Dr. Benjamin Martin, when describing the nature of the solar telescope, in his "Philosophia Britannica," vol. iii, p. 85, gives the following relation: "I can-

**sun's limb** This conclusion is deduced from the observation of October 2, 1843,\* stated above.

2. Another conclusion is, that during the space of 583 days, or about 19 months—the time this planet takes in moving from one conjunction with the sun to a like conjunction again—when its latitude at the time of its superior conjunction exceeds  $1^{\circ} 14'$ , it may be seen with an equatorial telescope every clear day without interruption, except about the period of its *inferior* conjunction, when its dark hemisphere is turned toward the earth, and a short time before and after it. When its geocentric latitude is less than  $1^{\circ} 14'$ , it will be hid only about four days before, and the same time after its superior conjunction. During the same period it will be invisible to the naked eye, and consequently no observations can be made upon it with a common telescope for nearly six months, and sometimes more, according as its declination is north or south, namely, about two or three months before, and the same time after its superior conjunction, except where there is a very free and unconfined horizon. In regard to the time in which this planet can be hid about the period of its *inferior* conjunction, I have ascertained from observation that it can never be hid longer than during a space of 2 days 22 hours, having seen Venus, about noon, like a fine, slender crescent, only 35 hours after she had

passed the point of her inferior conjunction; and in a late instance she was seen when little more than a day from the period of conjunction. The longest time, therefore, that this planet can be hid from view during a period of 583 days, is only about ten days; and when its latitude at the time of the superior conjunction equals or exceeds  $1^{\circ} 14'$ , it can be hid little more than two days. This is a circumstance which cannot be affirmed of any other celestial body, the sun only excepted.

3. That every variation of the phases of this planet, from a slender crescent to a full enlightened hemisphere, may, on every clear day, be conveniently exhibited by means of the equatorial telescope. This circumstance renders this instrument peculiarly useful in the instruction of the young in the principles of astronomy; for if the phase which Venus should exhibit at any particular time be known, the equatorial telescope may be directed to the planet, and its actual phase in the heavens be immediately exhibited to the astronomical pupil.

4. Since it is only at the period of the superior conjunction that this planet presents a full enlightened hemisphere, and since it is only when this phase is presented that both its diameters can be measured, it is of some importance that observations be made on it at the moment of conjunction, by means of powerful telescopes furnished with micrometers, so as to determine the difference (if any) between its polar and equatorial diameters.

5. Another conclusion from the observations on Venus is, that a moderate diminution of the aperture of the object-glass of the telescope is useful, and even necessary, in viewing this planet when near the sun. Its effect is owing in part to the direct solar rays being thereby effectually excluded, for when these rays enter directly into the tube of the telescope, it is very difficult, and almost impossible, to perceive this planet, or any other celestial body when in the vicinity of the sun.

#### OBSERVATIONS ON JUPITER AND OTHER PLANETS.

This planet is very easily distinguished in the day-time with a very moderate magnifying power, when it is not within  $30^{\circ}$  or  $35^{\circ}$  of the sun. The following extract from my memorandums may serve as a specimen: May 12, 1813, 1h. 40m., p. m., saw Jupiter with a power of 15 times, the aperture not contracted. The planet appeared so distinct with this power that I have reason to believe it would have been perceived with a power of six or seven times. When the aperture was contracted to 9-10ths of an inch, and afterward to half an inch, there was little perceptible difference in its appearance. It was then about  $58^{\circ}$  in longitude east of the sun.

Though Jupiter, when at a considerable distance from the sun, and near his position, appears to the naked eye with a brilliancy nearly equal to that of Venus, yet there is a very striking difference between them in respect of luster when viewed in daylight. Jupiter, when viewed with a high magnifying power in the day-time, always exhibits a very dull, cloudy appearance, whereas Venus appears with a moderate degree of splendor. About the end of June, 1813, between five and six in the evening, having viewed the planet Venus, then within  $20^{\circ}$  of the sun, and which appeared with a moderate degree of luster, I directed the telescope to Jupiter, at that time more than  $32^{\circ}$  from the sun, when the contrast between the two planets was very striking, Jupiter appearing so faint as to be just discernible,

admit them to be distant, and subtended too large angles to imagine them birds. In illustration of this subject, he states the following facts: On the 7th of September, 1820, after having observed for some time the eclipse of the sun which happened on that day, he intended to take a walk in the fields, and on crossing the town, he saw a numerous group of individuals of every age and sex, who had their eyes fixed in the direction of the sun. Farther on, he perceived another group, having their eyes in like manner turned toward the sun. He questioned an intelligent artist who was among them to learn the object that fixed his attention. He replied, "We are looking at the stars which are detaching themselves from the sun." "You may look yourself; that will be the shortest way to learn the fact." He looked, and saw, in fact, not stars, but balls of fire, of a diameter equal to the largest stars, which were projected in various directions from the upper hemisphere of the sun, with an incalculable velocity; and although this velocity of projection appeared the same in all, yet they did not all attain the same distance. These globes were projected at unequal and pretty short intervals. Several were often projected at once, but always diverging from one another. Some of them described a right line, and were extinguished in the distance: some described a parabolic line, and were in like manner extinguished; others, again, after having removed to a certain distance, in a right line, retrograded upon the same line, and seemed to enter, still luminous, into the sun's disc. The ground of this magnificent picture was a sky-blue, somewhat tinged with brown. Such was his astonishment at the sight of so majestic a spectacle, that it was impossible for him to keep his eyes off it until it ceased, which happened gradually as the eclipse wore off and the solar rays resumed their ordinary luster. It was remarked by one of the crowd that "the sun projected most stars at the time when it was palest;" and that the circumstance which first excited attention to this phenomenon was that of a woman, who cried out, "Come here! come and see the flames that are issuing from the sun!"

I have stated the above facts because they may afterward tend to throw light upon certain objects or phenomena with which we are at present unacquainted. The phenomenon of "falling stars" has of late years excited considerable attention, and it seems now to be admitted that at least certain species of these bodies descend from regions far beyond the limits of our atmosphere. This may be pronounced as certain with regard to the "November Meteors." May not some of the phenomena described above be connected with the fall of meteoric stones—the showers of falling stars seen on the 12th and 13th of November, or other meteoric phenomena whose causes we have hitherto been unable to explain? Or, may we conceive that certain celestial bodies, with whose nature and destination we are as yet unacquainted, may be revolving in different courses in the regions around us, some of them opaque and others luminous, and whose light is undistinguishable by reason of the solar effluence?

\* For an explanation of the manner of viewing Venus at her superior conjunction, see "Celestial Scenery."

though his apparent magnitude was nearly double that of Venus. In this observation a power of 65 was used. In his approach toward the sun, about the end of July, I could not perceive him when he was within  $16^{\circ}$  or  $17^{\circ}$  of his conjunction with that luminary. *These circumstances furnish a sensible and popular proof, independently of astronomical calculations, that the planet Jupiter is placed at a much greater distance from the sun than Venus, since its light is so faint as to be scarcely perceptible when more than 20 degrees from the sun, while that of Venus is distinctly seen amid the full splendor of the solar rays, when only about a degree from the margin of that luminary.* With a power of 65 I have been enabled to distinguish the *belt*s of Jupiter before sunset, but could never perceive any of his satellites until the sun was below the horizon. There are no observations which so sensibly and strikingly indicate the different degrees of light emitted by the different planets as those which are made in the day-time. To a common observer, during night, Jupiter and Venus appear, in a clear sky, nearly with equal brilliancy, and even Mars, when about the point of his *opposition* to the sun, appears with a luster somewhat similar, though tinged with a ruddy hue; but when seen in daylight their aspect is very dissimilar. This circumstance evidently indicates, 1. That these planets are placed at different distances from the sun, and consequently are furnished with different degrees of light proportional to the square of their distances from that luminary; and, 2. That there are certain circumstances connected with the surfaces and atmospheres of the planetary bodies which render the light they emit more or less intense, independently of their different distances from the central luminary; for Mars, though much nearer to the sun than Jupiter, is not so easily distinguished in the day-time, and even in the night-time appears with a less degree of luster.

My observations on *Saturn* in daylight have not been so frequent as those on Jupiter. I have been enabled to distinguish his ring several times before sunset with a power of 65, but his great southern declination, and consequent low altitude, at the periods when these observations were made, were unfavorable for determining the degree of his visibility in daylight; for a planet or a star is always more distinctly perceptible in a *high* than in a *low* altitude, on account of the superior purity of the atmosphere through which a celestial object is seen when at a high elevation above the horizon. This planet, however, is not nearly so distinctly visible in daylight as Jupiter, and I have chiefly seen it when the sun was not more than an hour or two above the horizon, but never at noonday, although it is probable that with powerful instruments it may be seen even at that period of the day. The planet *Mars*, is seldom distinctly visible in the day-time, except when at no great distance from its opposition to the sun. The following is a memorandum of an observation on Mars, when in a favorable position: October 24, 1836, saw the planet Mars distinctly with a power of about 60, at 40 minutes past 9, A. M., the sun having been above the horizon nearly three hours. It appeared tolerably distinct, but scarcely so brilliant as a fixed star of the first magnitude, though with apparently as much light as Jupiter generally exhibits when viewed in daylight. It could not be traced longer at the time, so as to ascertain if it could be seen at midday, on account of the interposition of the western side of the window of the place of observation.

The ruddy aspect of this planet—doubtless caused by a dense atmosphere with which it is environed—is one of the causes which prevents its appearing with brilliancy in the day-time. With respect to the planet *Mercury*, I have had opportunities of observing it several times after sunrise and before sunset, about 10 or 12 days before and after its greatest elongation from the sun, with a power of 45. I have several times searched for this planet about noon, but could not perceive it. The air, however, at the times alluded to, was not very clear, and I was not certain that it was within the field of the telescope, and therefore I am not convinced but that, with a moderately high power, it may be seen even at noonday.

Such are some of the specimens of the observations I have made on the heavenly bodies in the day-time, and the conclusions which may be deduced from them. I have been induced to communicate them from the consideration that the most minute facts in relation to any science are worthy of being known, and may possibly be useful. They may at least gratify the astronomical tyro with some information which he will not find in the common treatises on Astronomy, and may perhaps excite him to prosecute a train of similar observations for confirming or correcting those which have been noted above.

Beside the deductions already stated, the following general conclusions may be noted: 1. That a celestial body may be as easily distinguished at noonday as at any time between the hours of nine in the morning and three in the afternoon, except during the short days in winter. 2. They are more easily distinguished at a high than at a low altitude—in the afternoon than in the morning, especially if their altitudes be low—and in the northern region of the heavens than in the southern. The difficulty of perceiving them at a low altitude is obviously owing to the thick vapors near the horizon. Their being less easily distinguished in the morning than in the afternoon is owing to the undulations of the atmosphere, which are generally greater in the morning than in the afternoon. This may be evidently perceived by looking at distant land objects at those times, in a hot day, through a telescope which magnifies about 40 or 50 times, when they will be found to appear tremulous and distorted in consequence of these undulations, especially if the sun be shining bright. In consequence of this circumstance, we can seldom use a high terrestrial power with effect on land objects except early in the morning and a short time before sunset. Their being more easily distinguished in the northern region of the heavens is owing to that part of the sky being of a deeper azure, on account of its being less enlightened than the southern with the splendor of the solar rays.

#### UTILITY OF CELESTIAL DAY OBSERVATIONS.

The observations on the heavenly bodies in the day-time, to which I have now directed the attention of the reader, are not to be considered as merely gratifications of a rational curiosity, but may be regarded subservient to the promotion of astronomical science. As to the planet Venus: when I consider the degree of brilliancy it exhibits, even in daylight, I am convinced that useful observations might frequently be made on its surface in the day-time, to determine some of its physical peculiarities and phenomena. Such observations might set at rest any disputes which may still exist respecting the period of rotation of this planet. Cassini, from observations on a

bright spot, which advanced  $20^\circ$  in 24h. 34m., determined the time of its rotation to be 23 hours 20 minutes. On the other hand, Bianchini, from similar observations, concluded that its diurnal period was 24 days and 8 hours. The difficulty of deciding between these two opinions arises from the short time in which observations can be made on this planet, either before sunrise or after sunset, which prevents us from tracing with accuracy the progressive motion of its spots for a sufficient length of time; and, although an observer should mark the motion of the spots at the same hour on two succeeding evenings, and find they had moved forward  $15^\circ$  in 24 hours, he would still be at a loss to determine whether they had moved only  $15^\circ$  in all since the preceding observation, or had finished a revolution and  $15^\circ$  more. If, therefore, any spots could be perceived on the surface of Venus in the day-time, their motion might be traced, when she is in north declination, for 12 hours or more, which would completely settle the period of rotation. That it is not improbable that spots fitted for this purpose may be discovered on her disc in the day-time, appears from some of the observations of Cassini, who saw one of her spots when the sun was more than eight degrees above the horizon.\* The most distinct and satisfactory views I have ever had of this planet were those which I obtained in the day-time, in summer, when it was viewed at a high altitude with a  $4\frac{1}{2}$  inch achromatic telescope, carrying a power of 150. I have at such times distinctly perceived the distinction between the shade and color of its margin and the superior luster of its central parts, and some spots have occasionally been seen, though not so distinctly marked as to determine its rotation. Such distinct views are seldom to be obtained in the evening after sunset, on account of the undulations of the atmosphere, and the dense mass of vapors through which the celestial bodies are viewed when near the horizon.

Nor do I consider it altogether improbable that its *satellite* (if it have one, as some have supposed) may be detected in the day-time, when this planet is in a favorable position for such an observation, particularly when a pretty large portion of its enlightened surface is turned toward the earth, and when its satellite, of course, must present a similar phase. About the period of its greatest elongation from the sun, and soon after it assumes a crescent phase in its approach to the inferior conjunction, may be considered as the most eligible times for prosecuting such observations. If this supposed satellite be about one-third or one-fourth of the diameter of its primary, as Cassini, Short, Baudouin, Montbarron, Montaigne, and other astronomers supposed, it must be nearly as large as Mercury, which has been frequently seen in daylight. If such a satellite have a real existence, and yet undistinguishable in daylight, its surface must be of a very different quality for reflecting the rays of light from that of its primary; for it is obvious to every one who has seen Venus with a high power in the day-time, that a body of equal brilliancy, though four times less in diameter, would be quite perceptible, and exhibit a visible disc. Such observations, however, would be made with much greater effect in Italy and other southern countries, and particularly in tropical climates, such as the southern parts of Asia and America, and in the West India islands, where the sky is more clear and serene, and where

the planet may be viewed at higher altitudes and for a greater length of time, without the interruption of clouds, than in our island.

Again, the apparent magnitudes of the fixed stars, the quantity of light they respectively emit, and the precise class of magnitude which should be assigned to them, might be more accurately determined by day observations than by their appearance in the nocturnal sky. All the stars which are reckoned to belong to the *first magnitude* are not equally distinguishable in daylight. For example, the stars *Alhaboran* and *Procyon* are not so easily distinguished, nor do they appear with the same degree of luster by day, as the stars  $\alpha$  *Lyrae* and *Capella*. In like manner, the stars *Altair*, *Alphard*, *Deub*, *Red*, *Alhague*, considered as belonging to the *second magnitude*, are not equally distinguishable by the same aperture and magnifying power, which seems to indicate that a different quantity of light is emitted by these stars, arising from a difference either in their magnitude, their distance, or the quality of the light with which they are irradiated.

The following are likewise practical purposes to which celestial day observations may be applied. In accurately adjusting circular and transit instruments, it is useful, and even necessary, for determining the exact position of the meridian, to take observations of certain stars which differ greatly in zenith distance, and which transit the meridian nearly at the same time. But as the stars best situated for this purpose cannot, at every season, be seen in the evenings, we must, in certain cases, wait for several months before such observations can be made, unless we make them in the day-time, which can very easily be done if the instrument have a telescope adapted to it, furnished with such powers as those above stated, or higher powers if required. I have likewise made use of observations on the stars in the day-time for adjusting a clock or watch to mean time, when the sun was in a situation beyond the range of the instrument, or obscured by clouds, and when I did not choose to wait until the evening. This may, at first view, appear to some as paradoxical, since the finding of a star in daylight depends on our knowing its right ascension from the sun, and this last circumstance depends, in some measure, on our knowing the true time. But if a watch or clock is known not to have varied above seven or eight minutes from the time, a star of the first magnitude may easily be found by moving the telescope a little backward or forward until the star appear; and when it is once found, the exact variation of the movement is then ascertained by comparing the calculations which were previously necessary with the time pointed out by the nonius on the equatorial circle; or, in other words, by ascertaining the difference between the time assumed and the time indicated by the instrument when the star appears in the center of the field of view. All this may be accomplished in five or six minutes.

Beside the practical purposes now stated, the equatorial telescope is perhaps the best instrument for instructing a learner in the various operations of practical astronomy, and particularly for enabling him to distinguish the names and positions of the principal stars; for when the right ascension and declination of any star is known from astronomical tables, the telescope may be immediately adjusted to point to it, which will infallibly prevent his mistaking one star for another. In this way, likewise the precise position of the planets *Mercury*, *Uranus*, *Vesta*, *Juno*, *Ceres*, *Pallas*, a small comet, a nebula, a double star or any

\* See Long's *Astronomy*, vol. ii, p. 467, and *Encyclopedia Britannica*, vol. ii, p. 436, 3d edition.

other celestial body not easily distinguishable by the naked eye, may be readily pointed out, when its right ascension and declination are known to a near approximation.

In conclusion, I cannot but express my surprise that the equatorial telescope is so little known by many of the lovers of astronomical science. In several respectable academies in this part of Britain, and, if I am not misinformed, in most of our universities, this instrument is entirely unknown. This is the more unaccountable, as a small equatorial may be purchased for a moderate sum, and as there is no single instrument so well adapted for illustrating all the operations of practical astronomy. Where very great accuracy is not required, it may occasionally be made to serve the general purposes of a *transit instrument* for observing the passages of the sun and stars across the meridian. It may likewise be made to serve as a *theodolite* for surveying land and taking horizontal angles—as a *quadrant* for taking angles of altitude—as a *level*—as an *equal altitude instrument*—an *azimuth instrument* for ascertaining the sun's distance from the north or south points of the horizon—and as an accurate universal sundial, for finding the exact *mean* or *true* time on any occasion when the sun is visible. The manner of applying it to these different purposes will be obvious to every one who is in the least acquainted with the nature and construction of this instrument.

The price of a small equatorial instrument, such as that described p. 125, is about 16 guineas, exclusive of some of the eyepieces, which were afterward added for the purpose of making particular observations. Instruments of a larger size, and with more complicated machinery, sell from 50 to 100 guineas and upward. Messrs. W. and S. Jones, Holborn, London, construct such instruments.

ON THE QUADRANT.

Every circle being supposed to be divided into 360 equal parts or degrees, it is evident that 90 degrees, or the fourth part of a circle, will be sufficient to measure all angles between the horizon of any place and the line perpendicular to it which goes up to the zenith. Thus, in fig. 87, the line *CB* represents the plane of the horizon. *ACB* *H*, the quadrant; *A* *C* the perpendicular to the horizon; and *A*, the zenith point. If the lines *BC* and *CA* represent a pair of compasses with the legs standing perpendicular to each other, and the

Fig. 87.

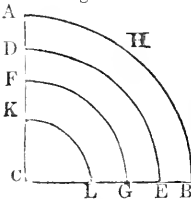

would be from the smallest to the largest quadrant that could be formed—they would all contain exactly 90 degrees each. By the application of this principle, the comparative measure of angles may be extended to an indefinite distance. By means of an instrument constructed in the form of a quadrant of a circle, with its curved edge divided into 90 equal parts, the altitude of any object in the heavens can at any time be determined.

There are various constructions of this instrument, some of them extremely simple, and others

considerably complex and expensive, according to the degree of accuracy which the observations require. The following is a description of the *Pillar Quadrant*, as it was made by Mr. Bird for the Observatory of Greenwich, and several Continental observatories.

This instrument consists of a quadrant, *EEH* *GL* (fig. 88,) mounted on a pillar *B*, which is supported by a tripod, *AA*, resting on three foot-screws. The quadrant, the pillar, and the horizontal circle all revolve round a vertical axis. A telescope, *H*, is placed on the horizontal radius, and is directed to a meridian mark previously made on some distant object for placing the plane of the instrument in the meridian, and also for setting

Fig. 88.

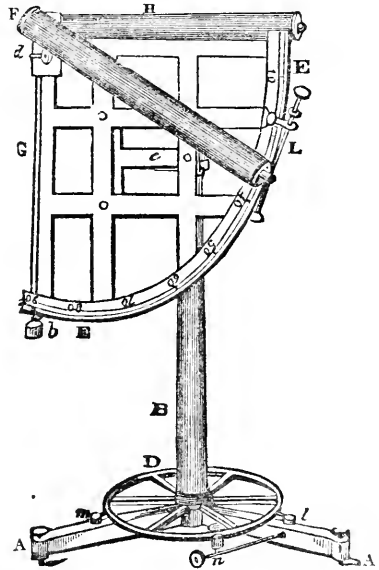

the zero, or beginning of the scale, truly horizontal. This is sometimes done by a level instead of a telescope, and sometimes by a plumb-line, *G*, suspended from near the center, and brought to bisect a fine dot made on the limb, where a microscope is placed to examine the bisection. The weight or plummet at the end of the plumb-line is suspended in the cistern of water *b*, which keeps it from being agitated by the air. A similar dot is made for the upper end of the plumb-line upon a piece of brass, adjustable by a screw, *d*, in order that the line may be exactly at right angles to the telescope when it is placed at *O*. The quadrant is screwed by the center of its frame against a piece of brass, *e*, with three screws, and this piece is screwed to the top of the pillar *B* with other three screws. By means of the first three screws the plane of the quadrant can be placed exactly parallel to the vertical axis, and by the other three screws the telescope *H*, can be placed exactly perpendicular to it. The nut of the delicate screw *L* is attached to the end of the telescope *F* by a universal joint. The collar for the other end is jointed in the same manner to a clamp, which can be fastened to any part of the limb. A similar clamp screw and slow motion is seen at *n* for the lower circle, which is intended to hold the circle fast and adjust its motion. The divisions of the lower, or horizontal circle, are read by verniers, or noniuses, fixed to the arms of the tripod at

*l* and *m*; and, in some cases, three are used to obtain greater accuracy.

In using this quadrant, the axis of the telescope *H* is adjusted to a horizontal line, and the plane of the quadrant to a vertical line by the means already stated. The screw of the clamp *L* is then loosened, and the telescope directed to the star or other object whose altitude is required. The clamp-screw being fixed, the observer looks through the telescope, and with the nut of the screw *L* he brings the telescope into a position where the star is bisected by the intersection of the wires in the field of the telescope. The divisions are then to be read off upon the vernier, and the altitude of the star will be obtained. By means of the horizontal circle *D*, all angles in the plane of the horizon may be accurately measured, such as the amplitudes and azimuths of the celestial bodies.

Quadrants of a more simple construction than the above may be occasionally used, such as Gunter's, Cole's, Sutton's, and others; but none of these is furnished with telescopes or telescopic sights, and therefore an altitude cannot be obtained by them with the same degree of accuracy as with that which has been now described.

By means of the quadrant, not only the altitudes of the heavenly bodies may be determined, but also the distances of objects on the earth by observations made at two stations; the altitude of fire-balls and other meteors in the atmosphere; the height of a cloud by observation on its altitude and velocity; and numerous other problems, the solution of which depends upon angular measurements. A *Mural Quadrant* is the name given to this instrument when it is fixed upon a wall of stone, and in the plane of the meridian, such as the quadrant which was erected by Flamsteed in the Observatory at Greenwich. Although the quadrant was formerly much used in astronomical observations, yet it may be proper to state that its use has now been almost completely superseded by the recent introduction of *Astronomical Circles*, of which we shall now give the reader a very short description, chiefly taken from Troughton's account of the instrument he constructed, as found in Sir D. Brewster's Supplement to Ferguson's Astronomy.

#### THE ASTRONOMICAL CIRCLE.

An astronomical circle is a *complete circle* substituted in place of the quadrant, and differs from it only in the superior accuracy with which it enables the astronomer to make his observations. The large vertical or declination circle *CC* (fig. 89) is composed of two complete circles, strengthened by an edge-bar on their inside, and firmly united at their extreme borders by a number of short braces or bars, which stand perpendicular between them, and which keep them at such a distance as to admit the achromatic telescope *T T*. This double circle is supported by 16 conical bars, firmly united, along with the telescope to a horizontal axis. The exterior limb of each circle is divided into degrees and parts of a degree, and these divisions are divided into seconds by means of the micrometer microscopes *m m*, which read off the angle on opposite sides of each circle. The cross wires in each microscope may be moved over the limb, until they coincide with the nearest division of the limb, by means of the micrometer screws *c c*, and the space moved through is ascertained by the divisions on the graduated head above *e*, assisted by a scale within the microscope. The microscopes are supported by two arms proceeding from a small circle concentric

with the horizontal axis, and fixed to the vertical columns. This circle is the center upon which they can turn round nearly a quadrant for the purpose of employing a new portion of the divisions of the circle, when it is reckoned prudent to repeat any delicate observations upon any part of the limb. At *h* is represented a level for placing the axis in a true horizontal line, and at *k* is fixed another level parallel to the telescope for bringing the zero of the divisions to a horizontal position. The horizontal axis to which the vertical circle and the telescope are fixed is equal in length to the distance between the vertical pillars, and its pivots are supported by semicircular bearings placed at the top of each pillar. These two vertical pillars are firmly united at their bases to a crossbar, *f*. To this crossbar is also fixed a vertical axis about three feet long, the

Fig. 89.

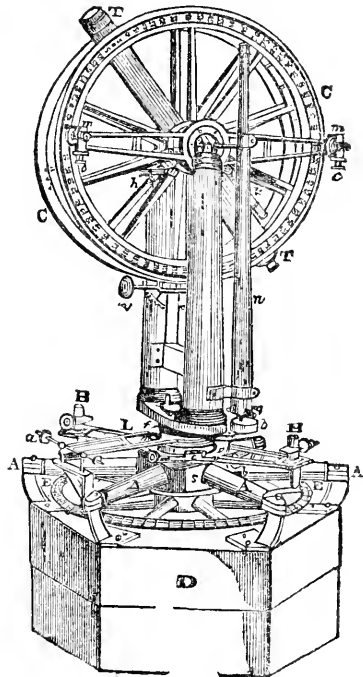

end of which, terminating in an obtuse point, rests in a brass conical socket firmly fastened to the bottom of the hollow in the stone pedestal *D*, which receives the vertical axis. This socket supports the whole weight of the movable part of the instrument. The upper part of the vertical axis is supported by two pieces of brass, one of which is seen at *e*, screwed to the ring *l*, and containing a right-angle, or *Y*. At each side of the ring, opposite to the points of contact, is placed a tube containing a helical spring, which, by a constant pressure on the axis, keeps it against its bearings, and permits it to turn, in these four points of contact, with an easy and steady motion. The two bearings are fixed upon two rings capable of a lateral adjustment; the lower one by the screw *d*, to incline the axis to the east or west, while the screw *b* gives the upper one, *i*, a motion in the plane of the meridian. By this means the axis may be adjusted to a perpendicular position

as exactly as by the usual method of the tripod with foot-screws. These rings are attached to the center-piece *s*, which is firmly connected with the upper surface of the stone by six conical tubes *A, A, A, &c.* and brass standards at every angle of the pedestal. Below this frame lies the azimuth circle, *E E*, consisting of a circular limb, strengthened by ten hollow cones firmly united with the vertical axis, and consequently turning freely along with it. The azimuth circle, *E E*, is divided and read off in the same manner as the vertical circle. The arms of the microscopes, *B B*, project from the ring *i*, and the microscopes themselves are adjustable by screws, to bring them to zero and to the diameter of the circle. A little above the ring *i* is fixed an arm, *L*, which embraces and holds fast the vertical axis with the aid of a clamp-screw. The arm *L* is connected at the extremity with one of the arms *A*, by means of the screw *a*, so that by turning this screw a slow motion is communicated to the vertical axis and the azimuth circle.

In order to place the instrument in a true vertical position, a plumb-line, made of fine silver wire, is suspended from a small hook at the top of the vertical tube *n*, connected by braces with one of the large pillars. The plumb-line passes through an angle in which it rests, and by means of a screw may be brought into the axis of the tube. The plummet at the lower end of the line is immersed in a cistern of water, *t*, in order to check its oscillations, and is supported on a shelf proceeding from one of the pillars. At the lower end of the tube *n* are fixed two microscopes, *o* and *p*, at right-angles to one another, and opposite to each is placed a small tube containing a lucid point. The plumb-line is then brought into such a position by the screws *d b*, and by altering the suspension of the plumb-line itself, that the image of the luminous point, like the disc of a planet, is formed on the plumb-line, and accurately bisected by it. The vertical axis is then turned round, and the plumb-line examined in some other position. If it still bisects the luminous point, the instrument is truly vertical; but if it does not, one half of the deviation must be corrected by the screws *d b*, and the other half, by altering the suspension of the line until the bisection of the circular image is perfect in every position of the instrument.

It is not many years since circular repeating instruments came into general use. The principle on which the construction of a repeating circle is founded appears to have been first suggested by Professor Mayer, of Gottingen, in 1758; but the first person who applied this principle to measure round the limb of a divided instrument was Borda, who about the year 1789, caused a repeating circle to be constructed that would measure with equal facility horizontal and vertical angles. Afterward Mr. Troughton greatly improved the construction of Borda's instrument by the introduction of several contrivances, which insure, at the same time, its superior accuracy and convenience in use; and his instruments have been introduced into numerous observatories. Circular instruments, on a large scale, have been placed in the Royal Observatory of Greenwich, and in most of the principal observatories on the Continent of Europe. Although it is agreed on all hands that greater accuracy may be obtained by a repeating circle than by any other having the same radius, yet there are some objections to its use which do not apply to the altitude and azimuth circle. The following are the principal

objections, as stated in vol. i, of the *Memoirs of the Astronomical Society of London*:— 1. The origin of the repeating circle is due to *bad dividing*, which ought not to be tolerated in any instrument in the present state of the art. 2. There are three sources of fixed error which cannot be exterminated, as they depend more on the materials than on the workmanship; first, the zero of the level changes with variations of temperature; secondly, the resistance of the center work to the action of the tangent screws; and, thirdly, the imperfection of the screws in producing motion and in securing permanent positions. 3. The instrument is applied with most advantage to slowly moving or circumpolar stars; but in low altitudes these stars are seen near the horizon, where refraction interferes. 4. Much time and labor are expended, first in making the observations, and again in reducing them. 5. When any one step in a series of observations is bad, the whole time and labor are absolutely lost. 6. When the instrument has a telescope of small power, the observations are charged with errors of vision which the repeating circle will not cure. 7. This instrument cannot be used as a transit instrument, nor for finding the exact meridian of a place.

A great variety of directions is necessary in order to enable the student of practical astronomy thoroughly to understand and to apply this instrument to practice, which the limited nature of the present work prevents us from detailing. As this instrument consists of a variety of complicated pieces of machinery, it is necessarily somewhat expensive. A six-inch brass astronomical circle for altitudes, zenith or polar distances, azimuths, with achromatic telescopes, &c., is marked in Messrs. W. and S. Jones's catalogue of astronomical instruments at £27 6s. A circle 12 inches in diameter, from £36 15s. to £68 5s. An 18 inch ditto, of the best construction, £105. The larger astronomical circles for public observatories, from 100 to 1000 guineas and upward, according to their size, and the peculiarity of their construction.

#### THE TRANSIT INSTRUMENT.

A transit instrument is intended for observing celestial objects as they pass across the meridian. It consists of a telescope fixed at right angles to a horizontal axis, which axis must be so supported that what is called the *line of collimation*, or the line of sight of the telescope, may move in the plane of the meridian. This instrument was first invented by Romer, in the year 1689, but has since received great improvements by Troughton, Jones, and other modern artists. Transit instruments may be divided into two classes, *Portable* and *Fixed*. The portable instrument, when placed truly in the meridian, and well adjusted, may be advantageously used as a stationary instrument in an observatory, if its dimensions be such as to admit of a telescope of  $3\frac{1}{2}$  feet focal length; but when the main tube is only from 20 to 30 inches long, with a proportional aperture, it is more suited for a traveling instrument to give the exact time; and, when carried on board a ship in a voyage of discovery, may be taken on shore at any convenient place for determining the solar time of that place, and for correcting the daily rate of the chronometer, giving the time at the first meridian, so that the longitude of the place of observation may be obtained from the difference of the observed and indicated times, after the proper corrections have been made.



The following is a brief description of one of Mr. Troughton's portable transit instruments. In fig. 90,  $PP$  is an achromatic telescope firmly fixed by the middle to a double conical and horizontal axis  $HH$ , the pivots of which rest on angular bearings called  $Y$ 's, at the top of the standards  $BB$ , rendered steady by oblique braces  $DD$ , fastened to the central part of the circle  $AA$ . In large fixed instruments, the pivots and angular bearings are supported on two massive stone pillars, sunk several feet into the ground, and are sometimes supported by mason-work, to secure perfect stability. The axis  $HH$  has two adjustments, one for making it exactly level, and the other for placing the telescope in the meridian. A graduated circle,  $L$ , is fixed to the extremity of the pivot, which extends beyond one of the  $Y$ 's and the two radii that carry the verniers,  $a$ , are fitted to the extremities of the pivot in such a way as to turn round independent of the axis. The double verniers have a small level attached to them, and a third arm,  $b$ , which is connected with the standard  $B$  by means of a screw, is. If the verniers are placed, by means of the level, in a true horizontal position, when the axis of the telescope is horizontal, and the arm  $b$  screwed by the screws to the standard  $B$ , the verniers will always read off

Fig. 90.

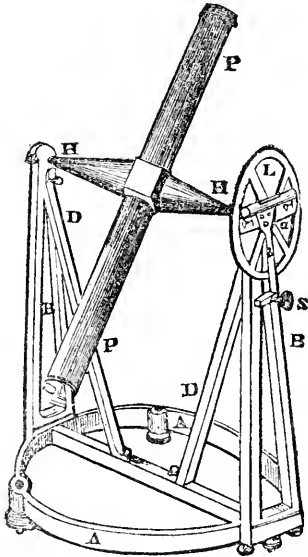

the inclination of the telescope, and will enable the observer to point it to any star by means of its meridian altitude. The whole instrument rests on three foot-screws entered into the circle  $AA$ . In the field of view of the telescope there are several parallel vertical wires, crossed at right

angles with a horizontal one, and the telescope is sometimes furnished with a diagonal eyepiece for observing stars near the zenith. A level likewise generally accompanies the instrument, in order to place it horizontal by being applied to the pivots of the axis.

In order to fix the transit instrument exactly in the meridian, a good clock regulated to sidereal time is necessary. This regulation may be effected by taking equal altitudes of the sun or a star before and after they pass the meridian, which may be done by small quadrants or by a good sextant. The axis  $H$  of the instrument is then to be placed horizontal by a spirit level, which accompanies the transit, and the greatest care must be taken that the axis of vision describes in the heavens a great circle of the sphere. To ascertain whether the telescope be in the plane of the meridian, observe by the clock when a circumpolar star seen through the telescope transits both above and below the pole, and if the times of describing the eastern and western parts of its circuit be equal, the telescope is then in the plane of the meridian; otherwise, certain adjustments must be made. When the telescope is at length perfectly adjusted, a landmark must be fixed upon at a considerable distance, the greater the better. This mark must be in the horizontal direction of the intersection of the cross wires, and in a place where it can be illuminated, if possible, in the night-time, by a lantern hanging near it; which mark being on a fixed object, will serve at all times afterward for examining the position of the telescope.

Various observations and adjustments are requisite in order to fixing a transit instrument exactly in the plane of the meridian. There is the adjustment of the level; the horizontal adjustment of the axis of the telescope; the placing of the parallel lines in the focus of the eyeglass, so as to be truly vertical, and to determine the equatorial value of their intervals; the collimation in azimuth, so that a line passing from the middle vertical line to the optical center of the object-glass is at right angles with the axis of the telescope's motion; the collimation in altitude, so that the horizontal line should cross the parallel vertical lines, not only at right angles, but also in the optical center of the field of view, with various other particulars, but of which our limited space will not permit us to enter into details. Those who wish to enter into all the minute details in reference to the construction and practical application of this and the other instruments above described, as well as all the other instruments used by the practical astronomer, will find ample satisfaction in perusing the Rev. Dr. Pearson's Introduction to Practical Astronomy, 4to, vol. ii.

A portable transit instrument, with a cast-iron stand, the axis 12 inches in length, and the achromatic telescope about 20 inches, packed in a case sells at about 16 guineas; with a brass-framed stand and other additions, at about 20 guineas. Transit instruments of larger dimensions are higher in proportion to their size, &c.

## CHAPTER III.

### ON OBSERVATORIES.

In order to make observations with convenience and effect on the heavenly bodies, it is expedient that an *observatory*, or place for making the requisite observations, be erected in a proper situation. The following are some of the leading features of a spot adapted for making celestial observations:

1. It should command an extensive visible horizon all around, particularly toward the south and the north.
2. It should be a little elevated above surrounding objects.
3. It should be, if possible, at a considerable distance from manufactories, and other objects which emit much smoke or vapor, and even from chimney-tops where no sensible smoke is emitted, as the heated air from the top of funnels causes undulations in the atmosphere.
4. It should be at a distance from swampy ground or valleys that are liable to be covered with fogs and exhalations.
5. It should not, if possible, be too near public roads, particularly if paved with stones, and frequented by heavy carriages, as in such situations undulations and tremulous motions may be produced injurious to the making of accurate observations with graduated instruments.
6. It is expedient that the astronomical observer should have access to some distant field within a mile of the observatory, on which a meridian mark may be fixed after his graduated instruments are properly adjusted. The distance at which a meridian mark should be erected will depend in part on the focal length of the telescope generally used for making observations on the right ascensions and declinations of the stars. It should be fixed at such a distance that the mark may be distinctly seen without altering the focus of the telescope when adjusted to the sun or stars, which, in most cases, will require to be at least half a mile from the place of observation, and more if it can be obtained.

Observatories may be distinguished into public and private. A *private* observatory may be comprehended in a comparatively small building, or in the wing of a building of ordinary dimensions for a family, provided the situation is adapted to it. Most of our densely peopled towns and cities, which abound in narrow streets and lanes, are generally unfit for good observatories, unless at an elevated position at their extremities. Public observatories, where a great variety of instruments is used, and where different observers are employed, require buildings of larger dimensions, divided into a considerable number of apartments. The observatory of *Greenwich* is composed principally of two separate buildings, one of which is the observatory properly so called, where the assistant lives and makes all his observations; the other is the dwelling-house in which the astronomer royal resides. The former consists of three rooms on the ground-floor, the middle of which is the assistant's sitting and calculating room, furnished with a small library of such books only as are necessary for his computations, and an accurate clock made by the celebrated Graham, which once served Dr. Halley as a transit clock.

Immediately over this is the assistant's bedroom, with an alarm to awake him to make his observations at the proper time. The room on the eastern side of this is called the *transit-room*, in which is an eight feet transit instrument, with an axis of three feet, resting on two pieces of stone, made by Mr. Bird, but successively improved by Messrs. Dollond, Troughton, and others. Here is also a chair to observe with, the back of which lets down to any degree of elevation that convenience may require. On the western side is the *quadrant-room*, with a stone pier in the middle running north and south, having on its eastern face a mural quadrant of eight feet radius, by which observations are made on the southern quarter of the meridian, through an opening in the roof of three feet wide, produced by means of two sliding shutters. On the western face is another mural quadrant of eight feet radius, the frame of which is of iron and the arch of brass, which is occasionally applied to the north quarter of the meridian. In the same room is the famous zenith sector, twelve feet long, with which Dr. Bradley made the observations which led to the discovery of the nutation of the earth's axis and the aberration of the light of the fixed stars. Here are also Dr. Hooke's reflecting quadrant, and three time-keepers by Harrison. On the south side of this room a small wooden building is erected for the purpose of observing the eclipses of Jupiter's satellites, occultations of stars by the moon, and other phenomena which require merely the use of a telescope, and the true or mean time. It is furnished with sliding shutters on the roof and sides to view any part of the hemisphere from the prime vertical down to the southern horizon. It contains a forty inch achromatic with a triple object-glass, and also a five feet achromatic by Messrs. John and Peter Dollond, a two feet reflecting telescope by Edwards, and a six feet reflector by Herschel. Above the dwelling-house is a large octagonal room, which is made the repository for certain old instruments, and for those which are too large to be used in the other apartments. Among many other instruments, it contains an excellent ten feet achromatic by Dollond, and a six feet reflector by Short. Upon a platform, in an open space, is erected the great reflecting telescope constructed by Mr. Ramage of Aberdeen, on the Herschelian principle, which has a speculum of 15 inches diameter and 25 feet focal length, remarkable for the great accuracy and brilliancy with which it exhibits celestial objects. Various other instruments of a large size and of modern construction have of late years been introduced into this observatory, such as the large and splendid transit instrument constructed by Troughton, in 1816, the two large mural circles by Troughton and Jones, the transit clock by Mr. Hardy, and several other instruments and apparatus which it would be too tedious to enumerate and describe.

Every observatory, whether public or private, should be furnished with the following instruments: 1. A transit instrument for observing the meridian passage of the sun, planets, and stars. 2. A good clock, whose accuracy may be depended upon. 3. An achromatic telescope of at least 44 inches focal distance, with powers of from 45 to 180, for viewing planetary and other phenomena; or a good reflecting telescope at least three feet long, and the speculum five inches in diameter. 4. An equatorial instrument, for viewing the stars and planets in the day-time, and for finding the right ascension and declination of a comet, or any other celestial phenomenon. Where this instrument is possessed, and in cases where no great degree of accuracy is required, the equatorial may be made to serve the general purposes of a transit instrument.

A private observatory might be constructed in any house which has a commanding view of the heavens, provided there is an apartment in it in which windows may be placed, or openings cut out fronting the north, the south, the east, and the west. The author of this work has a small observatory erected on the top of his house, which commands a view of 26 miles toward the east, 30 miles toward the west and north-west, and about twenty miles toward the south, at an elevation of more than 200 feet above the level of the sea and the banks of the Tay, which are about half a mile distant. The apartment is 12½ feet long by 8½ wide, and 8½ feet between the floor and the roof. It has an opening on the north, by which observations can be made on the pole-star; a window on the south, by which the meridian passages of the heavenly bodies may be observed; another opening toward the east, and a fourth opening, consisting of a door, toward the west. There is a pavement of lead on the outside, all around the observatory-room, inclosed by a stone parapet 3½ feet high, the upper part of which is coped with broad flat stones, in certain parts of which grooves or indentations are made for receiving the feet of the pedestal of an achromatic telescope, which form a steady support for the telescope in the open air, when the weather is calm and serene, and when observations are intended to be made on any region of the heavens. By placing an instrument on this parapet, it may be directed to any point of the celestial canopy except a small portion near the northern horizon, which is partly intercepted by a small hill. In the following ground plan, fig. 91, *A A A* is the parapet surrounding the observatory room; *B B B*, a walk around it nearly three feet broad, covered with lead. *O* is the apartment for the observatory, having an opening, *C*, to the north; another opening, *D*, to the east; *E* is a window which fronts the south, and *F* is a door fronting the west, by which an access is obtained to the open area on the outside. *G H I* is an area on the outside, toward the south, covered with lead, 15 feet long from *G* to *H*, and 6½ feet from *E* to *I*, from which a commanding view of the southern, eastern, and western portions of the heavens may be obtained; *e e e e* are positions on the top of the parapet where a telescope may be conveniently placed, when observations are intended to be made in the open air. The top of this parapet is elevated about 30 feet from the level of the ground. On the roof of the observatory, about 12 feet above its floor, on the outside, is a platform of lead, surrounded by a railing six feet by five, with a seat, on which observations either on celestial or terrestrial objects may occasionally be made. *K* is a door or

hatchway, which forms an entrance into the observatory from the apartments below, which folds down, and forms a portion of the floor.

Fig. 91.

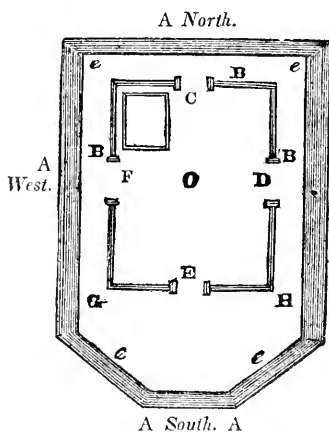

In public observatories, where zenith or polar distances require to be measured, it is necessary that there should be a dome, with an opening across the roof, and down the north and south walls. Should an altitude or azimuth circle, or an equatorial instrument be used, they will require a revolving roof with openings and doors on two opposite sides, to enable an observer to follow a heavenly body across all the cardinal points. The openings may be about 15 inches wide, and the roof need not be larger than what is requisite for giving room to the observer and the instrument, lest its bulk and weight should impede its easy motion. There have been various plans adopted for revolving domes. Fig. 92 represents a section of the rotatory dome constructed at East Sheen by the Rev. Dr. Pearson. This dome turns round

Fig. 92.

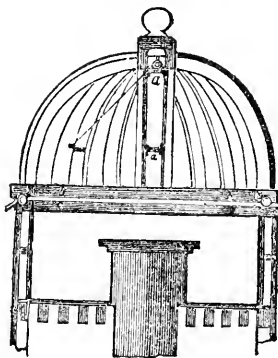

on three detached spheres of lignum vite, in a circular bed, formed partly by the dome, and partly by the cylindrical framework which surrounds the circular room of nine feet diameter. A section of this bed forms a square which the sphere just fills, so as to have a small play to allow for shrinking; and, when this dome is carried round, the spheres, having exactly equal diameters of 4¼ inches each, when placed at equal distances from one another, keep their relative places, and move together in a beautifully smooth manner. These spheres act as friction rollers in

two directions at the four points of contact, in case any obstacle is opposed to their progressive motion by the admission of dirt, or by any change of figure of the wood that composes the rings of the dome and of the gangway. No groove is here made but what the weight of the roof resting on the hard sphere occasions. The dome itself moves twice round for the balls once, and has, in this way, its friction diminished. The wood of this dome is covered by Wyatt's patent copper, one square foot of which weighs upward of a pound; and the copper is so turned over the nails that fix it at the parts of junction that not a single nail is seen in the whole dome. This covering is intended to render the dome more permanent than if it had been made of wood alone. At the observatory at Cambridge the dome is made chiefly of iron. In the figure, *a a* represents one of the two oblong doors that meet at the apex of the cone, and a piece of sheet-copper, bent over the upper end of the door which shuts last, keeps the rain from entering at the place of junction. The two halves of the dome are united by brass rods passing through the door-cheeks of wainscot at *a* and *a* by means of nuts that screw upon their ends, which union allows the dome to be separated into two parts when there may be occasion to displace it. The wooden plate *b b*, which appears in a straight line, is a circular broad ring, to which the covering wainscot boards are made fast above the eaves, and *c c* is a similar ring forming the wall-plate or gangway on which the dome rests and revolves.

Fig. 92\* shows a small door that lies over the summit of the dome, and may be separately opened for zenith observations; the rod of metal, with a ring at the lower end passing through it; serves to open and shut this door, and at the same time carries upon its upper end a large ball, which falls back on the roof when the door is open, and keeps the door in a situation to be acted upon by

the hook of a handle that is used for this purpose. The doors *a a*, being curved, are made to open in two halves, the upper one being opened first, on account of its covering the end of the other; and the observer may open one or two doors, as may best suit his purpose. The weight of this dome is such that a couple of wedges, inserted by a gentle blow between the rings *b b* and *c c*, will keep it in its situation under the influence of the strongest wind.

Fig. 92.\*

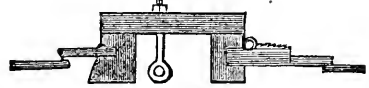

It may not be improper to remark, that in all observatories, and in every apartment where celestial observations are made, there should, if possible, be a uniform temperature; and, consequently, a fire should never be kept in such places, particularly when observations are intended to be made, as it would cause currents of air through the doors and other openings which would be injurious to the accuracy of observations. When a window is opened in an ordinary apartment where a fire is kept, there is a current of heated air which rushes out at the top, and a current of cold air which rushes in from below, producing agitations and undulations which prevent even a good telescope from showing celestial objects distinct and well-defined; and I have no doubt that many young observers have been disappointed in their views of celestial phenomena from this circumstance, when viewing the heavenly bodies from heated rooms in cold winter evenings, as the aerial undulations before the telescope prevent distinct vision of such objects as the belts of Jupiter, the spots of Mars, and the rings of Saturn.

## CHAPTER IV.

### ON ORRERIES OR PLANETARIUMS.

AN orrery is a machine for representing the order, the motions, the phases, and other phenomena of the planets. Although orreries and planetariums are not so much in use as they were half a century ago, yet, as they tend to assist the conceptions of the astronomical tyro in regard to the motions, order, and positions of the bodies which compose the solar system, it may not be inexpedient shortly to describe the principles and construction of some of these machines.

The reason why the name *Orrery* was at first given to such machines is said to have been owing to the following circumstance: Mr. Rowley, a mathematical instrument-maker, having got one from Mr. George Graham, the original inventor, to be sent abroad with some of his own instruments, he copied it, and made the first for the Earl of Orrery. Sir R. Steele, who knew nothing of Mr. Graham's machine, thinking to do justice to the first encourager, as well as to the inventor of such a curious instrument, called it an *Orrery*, and gave Mr. Rowley the praise due to Mr. Graham. The construction of such machines is not

a modern invention. The hollow sphere of Archimedes was a piece of mechanism of this kind, having been intended to exhibit the motions of the sun, the moon, and the five planets, according to the Ptolemaic system. The next orrery of which we have any account was that of Posidonius, who lived 80 years before the Christian era, of which Cicero says, "If any man should carry the sphere of Posidonius into Scythia or Britain, in every revolution of which the motions of the sun, moon, and five planets were the same as in the heavens each day and night, who in those barbarous countries could doubt of its being finished, not to say actuated, by perfect reason?" The next machine of this kind which history records was constructed by the celebrated Boethius, the Christian philosopher, about the year of Christ 510, of which it was said "that it was a machine pregnant with the universe—a portable heaven—a compendium of all things." After this period we find no instances of such mechanism of any note until the 16th century, when science began to revive and the arts to flourish. About this

time the curious clock in Hampton Court Palace was constructed, which shows not only the hours of the day, but the motions of the sun and moon through all the signs of the zodiac, and other celestial phenomena. Another piece of mechanism of a similar kind is the clock in the Cathedral of Strasburg, in which, beside the clock part, is a celestial globe or sphere with the motions of the sun, moon, planets, and the firmament of the fixed stars, which was finished in 1574.

Among the largest and most useful pieces of machinery of this kind is the great sphere erected by Dr. Long, in Pembroke Hall, in Cambridge. This machine, which he called the *Uranium*, consists of a planetarium, which exhibits the motion of the earth and the primary planets, the sun, and the motion of the moon around the earth, all inclosed within a sphere. Upon the sphere, beside the principal circles of the celestial globe, the zodiac is placed, of a breadth sufficient to contain the apparent path of the moon, with all the stars over which the moon can pass; also the ecliptic, and the heliocentric orbits of all the planets. The Earth in the planetarium has a movable horizon, to which a large movable brass circle within the sphere may be set coincident, representing the plane of the horizon continued to the starry heavens. The horizons, being turned round, sink below the stars on the east side, and make them appear to rise, and rise above the stars on the west side, and make them appear to set. On the other hand, the earth and the horizon being at rest, the sphere may be turned round to represent the apparent diurnal motion of the heavens. In order to complete his idea on a large scale, the doctor erected a sphere of 18 feet diameter, in which above 30 persons might sit conveniently, the entrance to which is over the south pole by six steps. The frame of the sphere consists of a number of iron meridians, the northern ends of which are screwed to a large round plate of brass with a hole in the center of it; through this hole, from a beam in the ceiling, comes the north pole, a round iron rod about three inches long, and which supports the upper part of the sphere to its proper elevation for the latitude of Cambridge, so much of it as is invisible in England being cut off; and the lower or southern ends of the meridians terminate on, and are screwed down to, a

pecting it in November, 1839. The essential parts of the machine still remain nearly in the same state as when originally constructed in 1753.

The machine which I shall now describe is of a much smaller and less complex description than that which has been noticed above, and may be made for a comparatively small expense, while it exhibits with sufficient accuracy the motions, phases, and positions of all the primary planets, with the exception of the new planets, which cannot be accurately represented on account of their orbits crossing each other. In order to the construction of the planetarium to which I allude, we must compare the proportion which the annual revolutions of the primary planets bear to that of the Earth. This proportion is expressed in the following table, in which the first column is the time of the Earth's period in days; the second, that of the planets; and the third and fourth are numbers very nearly in the same proportion to each other:

$365\frac{1}{4}$	:	88	:	83	:	20	for Mercury.
$365\frac{1}{4}$	:	$224\frac{2}{3}$	:	52	:	32	for Venus.
$365\frac{1}{4}$	:	677	:	40	:	75	for Mars.
$365\frac{1}{4}$	:	$4332\frac{1}{2}$	:	7	:	83	for Jupiter.
$365\frac{1}{4}$	:	$10759\frac{1}{3}$	:	5	:	148	for Saturn.
$365\frac{1}{4}$	:	30686	:	3	:	253	for Uranus.

On account of the number of teeth required for the wheel which moves Uranus, it is frequently omitted in planetariums, or the planet is placed upon the arbor which supports Saturn. If we now suppose a spindle or arbor with six wheels fixed upon it in a horizontal position, having the number of teeth in each corresponding to the numbers in the third column, namely, the wheel *A M* (fig. 93) of 83 teeth, *B L* of 52, *C K* of 50, for the earth, *D I* of 40, *E H* of 7, and *F G* of 5; and another set of wheels moving freely about an arbor having the number of teeth in the fourth column, namely, *A N* of 20, *B O* of 32, *C P* of 50, for the earth, *D Q* of 75, *E R* of 83, and *F S* of 143; then, if these two arbors of fixed and movable wheels be made of the size and fixed at the distance here represented, the teeth of the former will take hold of those of the latter, and turn them freely when the machine is in motion. These arbors, with their wheels, are to be placed

Fig. 93.

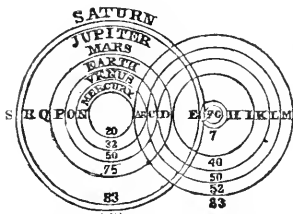

strong circle of oak 13 feet in diameter, which, when the sphere is put in motion, runs upon large rollers of lignum vitæ, in the manner that the tops of some windmills turn round. Upon the iron meridians is fixed a zodiac of tin painted blue, on which the ecliptic and heliocentric orbits of the planets are drawn, and the stars and constellations traced. The whole is turned round with a small winch, with as little labor as it takes to wind up a jack, although the weight of iron, tin, and the wooden circle is above a thousand pounds. This machine, though now somewhat neglected, may still be seen in Pembroke Hall, Cambridge, where I had an opportunity of in-

Fig. 94.

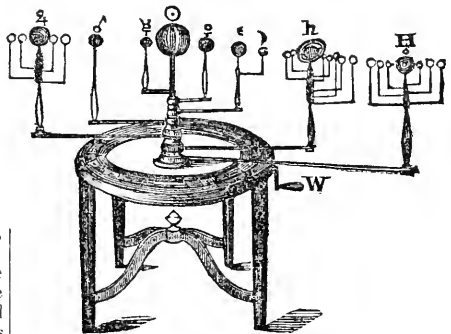

in a box of a proper size, in a perpendicular position; the arbor of fixed wheels to move in pivots at the top and bottom of the box, and the arbor of the movable wheels to go through the top of the box, and having on the top a wire fixed, and bent at a proper distance into a right angle upward, bearing on the top a small round ball representing its proper planet. If, then, on the

lower part of the arbor of fixed wheels be placed a pinion of screw-teeth, a winch turning a spindle with an endless screw, playing in the teeth of the arbor, will turn it with all its wheels, and these wheels will turn the others about, with their planets, in their proper and respective periods of time; for while the fixed wheel *C K* moves its equal *C P* once round, the wheel *A M* will move *A N* a little more than four times round, and will consequently exhibit the motion of Mercury; the wheel *E H* will turn the wheel *E R* about 1-12th round, representing the proportional motion of Jupiter; and the wheel *F G* will turn the wheel *F S* about 1-29.5th round, and represent the motion of Saturn, and so of all the rest.

The foregoing figure (94) represents the appearance of the instrument when completed. Upon the upper part of the circular box is pasted a zodiacal circle divided into 12 signs, and each sign into 30 degrees, with the corresponding days of the month. The wheelwork is understood to be within the box, which may either be supported by a tripod, or with four feet, as here represented. The moon and the satellites of Jupiter, Saturn, and Uranus, are movable only by the hand. When the winch *W* is turned, then all the primary planets are made to move in their respective velocities. The ball in the center represents the Sun, which is either made of brass, or of wood gilded with gold.

By this planetarium, simple as its construction may appear, a variety of interesting exhibitions may be made and problems performed, which may be conducive to the instruction of young students of Astronomy. I shall mention only a few of these as specimens.

1. When the planets are placed in their respective positions by means of an ephemeris or the Nautical Almanac, the relative positions of those bodies in respect to each other, the quarters of the heavens where they may be observed, and whether they are to be seen in the morning before sunrise or in the evening after sunset, may be at once determined. For example, on the 19th of December, 1844, the *heliocentric* places of the planets are as follows: Uranus, 2° of Aries; Saturn, 8° 24' of Aquarius; Jupiter, 7° 4' of Aries; Mars, 12° 45' of Libra; the Earth, 27° 46' of Gemini; Venus, 29° 48' of Virgo, Mercury, 7° 53' of Pisces. When the planets are placed on the planetarium in these positions, and the eye placed in a line with the balls representing the Earth and the Sun, all those situated to the left of the sun are to the east of him, and are to be seen in the evening, and those on the right in the morning. In the present case, Uranus, Saturn, Jupiter, and Mercury are evening stars, and Mars and Venus can only be seen in the morning. Jupiter is in an aspect nearly *quadrant*, or three signs distant from the sun, and Uranus is nearly in the same aspect. Saturn is much nearer the sun, and Mercury is not far from the period of its greatest *eastern* elongation. Mars is not far from being in a quartile aspect *west* of the sun, and Venus is near the same point of the heavens, approaching to the period of its greatest *western* elongation, and consequently will be seen before sunrise as a beautiful morning star. Jupiter and Uranus, to the east of the sun, appear nearly directly opposite to Venus and Mars, which are to the west of the sun. The phase\* of Venus is nearly that of

a half moon, and Mercury is somewhat gibbous, approaching to a half moon phase. If, now, we turn the machine by the winch until the index of the earth point at the 8th of August, 1845, we shall find the planets in the following positions: Mars and Saturn are nearly in opposition to the sun; Venus and Mercury are evening stars, at no great distance from each other, and Jupiter is a morning star. In like manner, if we turn the machine until the index point to any future months, or even succeeding years, the various aspects and positions of the planets may be plainly perceived. When the planets are moved by the winch in this machine, we see them all *at once* in motion around the sun, with the same respective velocities and periods of revolution which they have in the heavens. As the planets are represented in the preceding positions, Mercury, Jupiter, and Mars are evening stars, and Venus, Saturn, and Uranus morning stars, if we suppose the earth placed in a line with our eye and the sun.

2. By this instrument, the truth of the Copernican or solar system is clearly represented. When the planets are in motion, we perceive the planets Venus and Mercury to pass both before and behind the sun, and to have two conjunctions. We observe Mercury to be never more than a certain angular distance from the sun as viewed from the earth, namely, 27°, and Venus 47°. We perceive that the superior planets, particularly Mars, will be sometimes much nearer to the earth than at others, and therefore must appear larger at one time than at another, as they actually appear in the heavens. We see that the planets cannot appear from the earth to move with uniform velocity; for when nearest they appear to move faster, and slower when most remote. We likewise observe that the planets appear from the earth to move sometimes *direct*, or from west to east; then become retrograde, or from east to west, and between both to be *stationary*; all which particulars exactly correspond with celestial observations. For illustrating these particulars, there is a simple apparatus, represented by fig. 95, which consists of a hollow wire with a slit at top, which is placed over the arm of Mercury or Venus at *E*. The arm *D G* represents a ray of light coming from

Fig. 95.

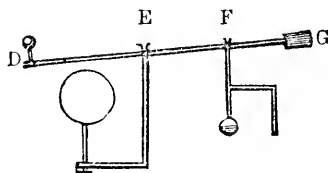

the planet at *D* to the earth at *F*. The planets being then in motion, the planet *D*, as seen in the heavens from the earth at *F*, will undergo the several changes of position which we have described above, sometimes appearing to go backward, and at other times forward. The wire prop, now supposed to be placed over Mercury at *E*, may likewise be placed over any of the other planets, particularly Mars, and similar phenomena will be exhibited.

This machine may likewise be used to exhibit the falsity of the Ptolemaic system, which places the earth in the center, and supposes the sun and all the planets to revolve around it. For this purpose, the ball representing the Sun is removed,

\* The balls which represent the different planets on this machine have their hemispheres painted black, with the white side turned directly to the sun, so that if the eye be placed in a line with the earth and the planet, particularly Mercury and Venus, its phase in the heavens at that time, as viewed with a telescope, may be distinctly perceived.

and placed on the wire or pillar which supports the Earth, and the ball representing the Earth is placed in the center. It will then be observed that the planets Mercury and Venus, being both within the orbit of the sun, cannot at any time be seen to go behind it, whereas in the heavens we as often see them go behind as before the sun. Again, it shows that as the planets move in circular orbits about the central earth, they ought at all times to appear of the same magnitude, while, on the contrary, we observe their apparent magnitudes in the heavens to be very variable, Mars, for example, appearing sometimes nearly as large as Jupiter, and at other times only like a small fixed star. Again, it is here shown that the planets may be seen at all distances from the sun: for example, when the sun is setting, Mercury and Venus, according to this arrangement, might be seen, not only in the south, but even in the eastern quarter of the heavens: a phenomenon which was never yet observed in any age. Mercury never appearing beyond  $27^\circ$  of the sun, nor Venus beyond  $48^\circ$ . In short, according to the system thus represented, it is seen that the motions of the planets should all be regular, and uniformly the same in every part of their orbits, and that they should all move the same way, namely, from west to east; whereas in the heavens they are seen to move with variable velocities, sometimes appearing stationary, and sometimes moving from east to west, and from west to east: all which circumstances plainly prove that the Ptolemaic cannot be the true system of the universe.

A planetarium such as that now described might be constructed with brass wheel-work for about five guineas. The brass wheel-work of one which I long since constructed cost about three guineas, and the other parts of the apparatus about two guineas more. The following are the

prices of some instruments of this kind as made by Messrs. Jones, 30 Lower Holborn, London:—  
 "An orrery, showing the motions of the Earth, Moon, and inferior planets, Mercury, and Venus, by wheel-work, the board on which the instrument moves being 13 inches diameter, £1.14s. 6d.  
 A planetarium, showing the motions of all the primary planets by wheel-work with  $1\frac{1}{2}$  inch or three inch papered globes, according to the wheel-work and the neatness of the stands, from £7 17s. 6d. to £10 10s.  
 Ditto, with wheel-work to show the parallelism of the Earth's axis, the motions of the Moon, her phases, &c., £18 18s.  
 Ditto, with wheel-work to show the Earth's diurnal motion, on a brass stand in mahogany case, £22 1s.  
 A small tellurian, showing the motion of the Earth and Moon, &c., £1 8s."

HENDERSON'S PLANETARIUM.

The following is a description of the most complete and accurate planetarium I have yet seen. The calculations occupied more than eight months. For this article I am indebted to my learned and ingenious friend, Dr. Henderson, F.R.A.S., who is known to many of my readers by his excellent astronomical writings.

Section of the wheel-work of a planetarium for showing with the utmost degree of accuracy the mean tropical revolutions of the planets round the sun, calculated by E. Henderson, LL.D., &c.

In the section the dark horizontal lines represent the wheel-work of the planetarium, and the annexed numerals the numbers of teeth in the given wheel. The machine has three axes or arbors, indicated by the letters *A B C*. Axis "*C*," the "yearly axis," is assumed to make one revolution in 365,242,236 days, or in 365 days 5h. 48m. 49.19s. and is furnished with wheels, 17, 44, 54, 36, 140, 96, 127, 86, which wheels are all firmly riveted to said axis, and consequently they turn,

Fig. 96.

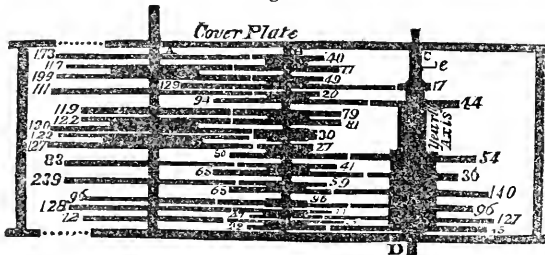

round with it in the same time. Axle "*B*" is a fixture: it consists of a steel rod, on which a system of pairs of wheels revolve; thus wheels 40 and 77 are made fast together by being riveted on the same collet, represented by the thick, dark space between them, as also of the rest: the several wheels on this axis may be written down thus:  $\frac{40}{77}$ ,  $\frac{49}{129}$ ,  $\frac{20}{94}$ ,  $\frac{79}{81}$ , 30,  $\frac{27}{59}$ ,  $\frac{41}{65}$ ,  $\frac{59}{65}$ , 96,  $\frac{77}{47}$ ,  $\frac{67}{42}$ . On axis *A*, a system of wheels, furnished with tubes, revolve, and these tubes carry horizontal arms, supporting perpendicular stems with the planets. The wheels on this axis are 173,  $\frac{119}{130}$ , 111, 119,  $\frac{122}{130}$ ,  $\frac{123}{130}$ , 83, 239, 96, 128, 72. From the following short description, the nature of their several actions will, it is presumed, be readily understood, viz:

MERCURY'S PERIOD. On the axis "*C*" at the bottom is wheel 86, which turns round in 365 days 5h. 48m. 49.19s. This wheel impels a small

wheel of 22 teeth, to which is made fast wheel 67, both revolving together at the foot of axis *B*; wheel 67 drives a wheel of 72 once round in the period of 87 days 23h. 14m. 36.1s.: this last mentioned wheel has a long tube, which turns on the steel axis *A*, and carries a horizontal arm with the planet Mercury round the sun in the time above noted.

VENUS'S PERIOD. On axis "*C*" is wheel 127, which drives wheel 47, to which is riveted a wheel of 77 teeth, which impels a wheel of 128 teeth on axis *A*, and causes it to make a revolution in 224 days 16h. 41m. 31.1s., and is furnished with a tube, which revolves over that of Mercury, and ascends through the cover of the machine, and bears an arm on which is placed a small ball representing this planet in the time stated.

**THE EARTH'S PERIOD.** The motion of the Earth round the Sun is simply effected as follows: the assumed value of axis "C" the "yearly axis," is 365 days 5h. 48m. 49.19s.; hence a system of wheels having the same number of teeth, or, at all events, the first mover and last wheel impelled, must be equal in their numbers of teeth. In this machine three wheels are employed, thus: a wheel having 96 teeth is made fast to the yearly axis C, and of course moves round with it in a mean solar year, as above noted; this wheel impels another wheel of 96 teeth on axis B, and this, in its turn, drives a third wheel of 96 teeth on axis A, and is furnished with a long tube which revolves over that of Venus, and ascends above the cover-plate of the machine, and bears a horizontal arm which supports a small terrestrial globe, which revolves by virtue of said wheels once round the sun in 365 days 5h. 48m. 49.19s.

**MARS'S PERIOD.** The revolution of this planet is effected as follows: a wheel of 140 teeth is made fast to the yearly axis C, and drives on axis B a wheel of 65 teeth, to which is fixed a wheel of 59 teeth, which impels a large wheel of 239 teeth on axis A once round the sun in 686 days 22h. 18m. 33.6s.: this last mentioned wheel is also furnished with a tube which revolves over that of the earth, and carries a horizontal arm bearing the ball representing Mars, and causes it to complete a revolution round the sun in the period named.

**THE ASTEROIDS.** The period of Vesta is accomplished thus, viz: on the yearly axis C is made fast a wheel of 36 teeth, which drives a wheel of 65 teeth, on axis B, to which is fixed a wheel of 41 teeth, which impels a wheel of 83 teeth on axis A once round in 1336 days 0h. 21m. 19.8s.; the tube of which last wheel ascends on that of Mars, and, like the rest, bears an arm supporting a ball representing this planet.

**JUNO'S PERIOD.** For the revolution of Juno, the yearly axis C is furnished with a wheel of 54 teeth, which impels a wheel of 50 teeth on axis B, to which is made fast a wheel of 27 teeth, which turns a wheel of 127 teeth on axis A once round in 1590 days 17h. 35m. 2.7s., and the tube of which ascends on that of Vesta, and supports a horizontal arm which carries a small ball representing this planet in the period named.

**CERES'S PERIOD.** The revolution of Ceres is derived from the period of Juno, because wheel-work taken from the unit of a solar year was not sufficiently accurate for the purpose, therefore on Juno's wheel of 127 teeth is fixed a wheel of 123 teeth, which drives a thick little bevel sort of wheel of 30 teeth on axis B: the reason of this small wheel being beveled is to allow its teeth to suit both wheels  $\frac{1}{3} \frac{2}{3}$ ; wheel 30 drives wheel 130 on axis A once round in 1681 days 6h. 17m. 22.4s., and the tube of wheel 130 turns on the tube of Juno, and ascends in a similar manner with the rest, and carries a horizontal arm supporting a small ball representing this planet, and is caused to revolve

round the Sun in the above-mentioned period (the period of Ceres to that of Juno is as 130 is to 123; hence the wheels used)

**PALLAS'S PERIOD.** The period of Pallas could not be derived from the solar year with sufficient accuracy, and recourse was had to an engrafted fraction on the period of Ceres, thus: on wheel 130 of Ceres is made fast a wheel of 122 teeth, which drives a wheel of 81 teeth on axis B, to which is fixed a wheel 79, which impels a wheel of 119 teeth on axis A, and is furnished with a tube which ascends, and turns on that of Ceres, and supports a horizontal arm, which bears a small ball representing this planet, which by virtue of the above train of wheels is caused to complete a revolution round the Sun in 1681 days 10h. 28m. 25.1s.

**JUPITER'S PERIOD.** The motion of this planet is derived from the period of a solar year, from the "yearly axis," thus: on this axis is made fast a wheel of 44 teeth, which turns a wheel of 94 teeth on axis B, to which is riveted a small wheel of 20 teeth, which impels a wheel on axis A having 111 teeth, which is furnished with an ascending tube which revolves over that of Pallas, and bears a horizontal arm which supports a ball representing this planet, which by the said train of wheels is caused to revolve round the Sun in 4330 days 14h. 39m. 35.7s.

**SATURN'S PERIOD.** The periodic revolution of Saturn is also taken from the solar year, viz: a small wheel of 17 teeth is fixed to the "yearly axis" near its top, and drives a wheel of 129 teeth on axis B, to which is made fast a wheel of 49 teeth, which turns a wheel of 199 teeth on axis A, whose tube ascends and revolves on that of Jupiter's tube, and supports an arm, having a ball representing Saturn and its rings, and which by the train of wheels is caused to perform a revolution round the Sun in the period of 10,746 days 19h. 16m. 50.8s.

**URANUS'S PERIOD.** The revolution of this planet could not be attained with sufficient accuracy from the period of a solar year: the period is engrafted on that of Saturn's, thus: a wheel of 117 teeth is made fast to wheel 199 of Saturn, and consequently revolves in Saturn's period. This wheel of 117 teeth drives a wheel on axis B having 77 teeth, to which is fixed a wheel of 40 teeth, which turns on axis A a large wheel of 173 teeth, whose tube ascends and revolves over that of Saturn, and carries a horizontal arm which supports a ball representing this planet, which is caused to complete its revolution by such a train of wheels in the period of 30,589 days 8h. 26m. 58.4s. Such is a brief description of the motions of this comprehensive and very accurate machine.

The axis A, on which the planet tubular wheels revolve, performs a rotation in 25 days 10 hours by virtue of the following train of wheels,  $\frac{61}{14} + \frac{70}{12}$  of 24 hours, that is, a pinion of 14 is assumed to revolve in 24 hours, and to drive a wheel of 61 teeth, to which is fixed a pinion of 12, which turns the wheel 70 in the period noted; to this wheel-axis it is made fast, and by revolving with it exhibits the Sun's rotation.



**DIURNAL HAND.** The machine is turned by a handle or winch, which is assumed to turn round in 24 hours, and from this rotation of 24 hours a train of wheel-work is required to cause the "yearly axis" C to turn once round in 365 days 5h. 48m. 49.19s., which is effected in the following manner, viz: the train found by the process of the reduction of continuous fractions is  $\frac{61}{14} + \frac{144}{18} + \frac{241}{23}$ , that is, in the train for turning the Sun, the same pinion 14 turns the same wheel 61, and turns a pinion of 18 leaves, to which is fixed a wheel of 144 teeth, having a pinion of 23 leaves, which impels a large wheel of 241 teeth once round in 365.-242236 days, or 365.1. 5h. 48m. 49.19s. The last mentioned wheel of 241 teeth is made fast to the under part of the "yearly axis" C at D, the handle having a pinion of 14 leaves there-for, and, transmitting its motion through the above train, causes the yearly axis to revolve in the same period.

**REGISTRATION DATES.** The planetarium is also furnished with a system of wheels for registering dates for either 10,000 years past or to come. The arrangement is not shown in the engraving (to prevent confusion), but it might be shortly described thus: near the top of the yearly axis is a hooked piece, e, which causes the tooth of a wheel of 100 teeth to start forward yearly; consequently, 100 starts of said wheel will cause it to revolve in 100 solar years; and it has a hand, which points on a dial on the cover of the machine the years: thus, for the present year, this hand will be over the number 45. This last-named wheel of 100 teeth has a pin, which causes a tooth of another wheel of 100 teeth to start once in 100 years; hence this last wheel will complete one revolution in 10,000 years; and it is for this purpose the former index or hand moves over a number yearly. The second index will pass over a number every 100 years; for

Planets' names.	Wheel-work.	Tropical periods produced by the wheel-work.					True mean tropical periods of the planets.				
		da.	ho.	m.	s.		da.	ho.	m.	s.	
Mercury.....	. . . . . $\frac{22}{85} + \frac{67}{27}$ of year	87.	23.	14.	36.	1	87.	23.	14.	36	
Venus.....	. . . . . $\frac{47}{127} + \frac{128}{77}$ "	224.	16.	41	31.	1	224.	16.	41.	36	
The Earth.....	Prime mover $96 + 96 + 96$ "	365.	5.	48.	49.	19	365.	5.	48.	49	
Mars.....	. . . . . $\frac{65}{140} + \frac{239}{59}$ "	686.	22.	18.	33.	6	686.	22.	18.	34	
Vesta.....	. . . . . $\frac{65}{36} + \frac{83}{41}$ "	1335.	0.	21.	19-	8	1335.	0.	21.	20	
Juno.....	. . . . . $\frac{50}{54} + \frac{127}{27}$ "	1590.	17.	35.	2.	7	1590.	17.	35.	1	
Ceres.....	. . . . . $\frac{130}{123} + 30$ of Juno	1681.	6:	17.	22.	4	1681.	6.	17.	22	
Pallas.....	. . . . . $\frac{81}{122} + \frac{119}{79}$ of Ceres	1681.	10.	28.	25.	1	1681.	10.	28.	42	
Jupiter.....	. . . . . $\frac{94}{44} + \frac{111}{20}$ of a year	4330.	14.	39.	35.	7	4330.	14.	39.	32	
Saturn.....	. . . . . $\frac{129}{17} + \frac{190}{49}$ "	10746.	19.	16.	50.	9	10746.	19.	16.	52	
Uranus.....	. . . . . $\frac{77}{117} + \frac{731}{40}$ of Saturn	30589.	8.	26.	58.	4	30589.	8.	26.	59	
The Sun's rotation	$\frac{61}{41} + \frac{70}{12}$ of 24 hrs.	25.	10.	0.	0.		25.	10.	0.	1	
The tropical period of the Earth round the Sun }	. . . . . $\frac{61}{14} + \frac{144}{18} + \frac{241}{23}$ "	365.	5.	48.	43,	19	365.	5.	48.	49	

the present year, the second-hand or index will be over the number 18, and will continue over it until the first index moves forward to 93; then both indexes will move at one time, viz: the first index to O O on the first concentric circle of the dial, and the second index to 19, denoting the year 1900, and so of the rest. By the ecliptic being divided in a series of four spirals, the machine makes a distinction between common and leap years, and indicates the common year as containing 365 days, and the leap year 366 days, by taking in a day in February every fourth year; thus, for any given period for 10,000 years past

or to come, the various situations and aspects of the planets may be ascertained by operating with this machine, and this for thousands of years without producing a sensible error either in space or time. This planetarium wheel-work is inclosed in an elegant mahogany box of twelve sides; is about five feet in diameter by ten inches in depth. At each of the twelve angles, or sides, small brass pillars rise, and support a large ecliptic circle, on which are engraven the signs, degrees, and minutes of the ecliptic, the days of the month, &c. This mahogany box with the wheel-work is supported by a tripod stand three feet in height, and

motion is communicated to the several balls representing the planets by turning the handle as before described. A planetarium of this complicated sort costs sixty guineas.

The foregoing is a tabular view of the wheel-work, periods, &c.

In the month of October last year, Dr. Henderson made a series of calculations for a new planetarium for the use of schools. It shows with considerable accuracy for 700 days the mean tropical revolutions of the planets round the sun. The machine consists of a system of brass wheels peculiarly arranged, and is inclosed in a circular case three feet in diameter, the top of which has the signs and degrees of the ecliptic laid down on it, as also the days of the months, &c. This planetarium costs only 45s., or, on a tripod stand, table-high, 55s.: the machine is put in motion by a handle on the outside. To the teachers and others connected with education, this planetarium must be of great importance, for without a proper elucidation of the principles of astronomy, that of Geography must be but confusedly understood. This planetarium is at present made by Mr. Doland, 9 White Conduit Grove, Islington, London.

The *Telurion* is a small instrument which should be used in connection with the planetarium formerly described. This instrument is intended to show the annual motion of the earth, and the revolution of the moon around it. It also illustrates the moon's phases and the motion of her nodes, the inclination of the Earth's axis, the causes of eclipses, the variety of seasons, and other phenomena. It consists of about eight wheels, pinions, and circles. A small instrument of this description may be purchased for about £1 8s., as stated on page 113.

#### ON THE VARIOUS OPINIONS WHICH WERE ORIGINALLY FORMED OF SATURN'S RING.

The striking and singular phenomenon connected with the planet Saturn, though now ascertained beyond dispute to be a ring or rings surrounding its body at a certain distance, was a subject of great mystery, and gave rise to numerous conjectures and controversies for a considerable time after the invention of the telescope by which it was discovered. Though it was first discovered in the year 1610, it was nearly 50 years afterward before its true form and nature were determined. Galileo was the first who discovered anything uncommon connected with Saturn: through his telescope he thought he saw that planet appear like two smaller globes on each side of a larger one; and after viewing the planet in this form for two years, he was surprised to see it becoming quite round, without its adjoining globes, and some time afterward to appear in the triple form. This appearance is represented in fig. 1 of the following engraving. In the year 1613, Scheiner, a German astronomer, published a representation of Saturn, in which this planet is exhibited as a large central globe, with two smaller bodies, one on each side, partly of a conical form, attached to the planet, and forming a part of it, as shown fig. 2. In the years 1640 and 1643, Ricciolus, an Italian mathematician and astronomer, imagined he saw Saturn as represented in fig. 3, consisting of a central globe, and two conical-shaped bodies completely detached from it, and published an account of it corresponding to this view. Heve-

lius, the celebrated astronomer of Dantzic, author of the *Selenographia* and other works, made many observations on this planet about the years 1643, 1649, and 1650, in which he appears to have obtained different views of the planet and its appendages, gradually approximating to the truth, but still incorrect. These views are represented

Fig. 97.

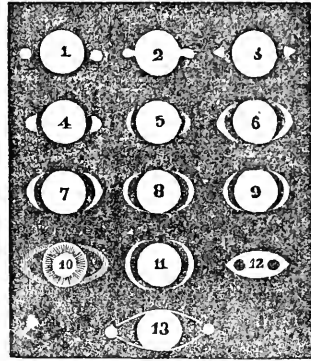

in figures 4, 5, 6, and 7. Fig. 4 nearly resembles two hemispheres, one on each side of the globe of Saturn. The other figures very nearly resemble the extreme parts of the ring as seen through a good telescope, but he still seems to have considered them as detached from each other as well as from Saturn. Figures 8 and 9 are views given by Ricciolus at a period posterior to that in which he supposed Saturn and his appendages in the form delineated in fig. 3. In these last delineations the planet was supposed to be inclosed in an elliptical ring, but this ring was supposed to be fixed to its two opposite sides.

Fig. 10 is a representation by Eustachius Divini, a celebrated Italian optician at Bologna. The shades represented on Saturn and the elliptical curve are incorrect, as this planet presents no such shadowy form. The general appearance here presented is not much unlike that which the ring of Saturn exhibits, excepting that the upper side of the ring should appear covering a portion of the orb of Saturn; but Divini seems to have conceived that the curve on each side was attached to the body of Saturn, for when Huygens immediately replied to him, and Divini wrote a rejoinder in 1661. Fig. 11 is the representation given by Francis Fontana, a Neapolitan Astronomer. This figure represents Saturn as having two crescents, one on each side, attached to its body, with intervals between the planet and the crescents. Fig. 12 is a view delineated by Gassendus, a celebrated French philosopher. It represents the planet as a large ellipsoid, having a large circular opening near each end, and if this representation were the true one, each opening would be at least 30,000 miles in diameter. Fig. 13, which is perhaps the most singular of the whole, is said to be one of the views of this planet given by Ricciolus. It represents two globes, each of which, in the proportion they here bear to Saturn, must be more than 30,000 miles in diameter. These globes were conceived as being

attached to the body of Saturn by curves or bands, each of which, in the proportion represented, must have been at least 7000 miles in breadth, and nearly 40,000 miles long. This would have exhibited the planet Saturn as a still more singular body than what we have found it to be; but no such construction of a planet has yet been found in the universe, nor is it probable that such a form of a planetary body exists.

It is remarkable that only two general opinions should have been formed respecting the construction of Saturn, as appears from these representations: either that this planet was composed of three distinct parts, separate from each other, or that the appendage on each side was *fixed* to the body of the planet. The idea of a ring surrounding the body of the planet at a certain distance from every part of it seems never to have been thought of until the celebrated Huygens, in 1655, 1656, and 1657, by numerous observations made on this planet, completely demonstrated that it is surrounded by a solid and permanent ring, which never changes its situation, and, without touching the body of the planet, accompanies it in its revolution around the sun. As the cause of all the erroneous opinions above stated was owing to the imperfection of the telescopes which were then in use, and their deficiency in magnifying power, this ingenious astronomer set himself to work in order to improve telescopes for celestial observations. He improved the art of grinding and polishing object-glasses, which he finished with his own hands, and produced lenses of a more correct figure, and of a longer focal distance, than what had previously been accomplished. He first constructed a telescope 12 feet long, and afterward one 23 feet long, which magnified about 95 times; whereas Galileo's best telescope magnified only about 33 times. He afterward constructed one 123 feet long, which magnified about 220 times. It was used without a tube, the object-glass being placed upon the top of a pole, and connected by a cord with the eyepiece. With such telescopes this ingenious artist and mathematician discovered the fourth satellite of Saturn, and demonstrated that the phenomenon which had been so egregiously misrepresented by preceding astronomers consisted of an immense ring surrounding the body, and completely detached from it. His numerous observations and reasonings on this subject were published in Latin in 1659, in a quarto volume of nearly 100 pages, entitled "*Systema Saturnium, sive de causis mirandorum Saturni Phenomenon, et Comite ejus Planeta Nova*," from which work the figures and some of the facts stated above have been extracted.

#### ON THE SUPPOSED DIVISIONS OF THE EXTERIOR RING OF SATURN.

From the period in which Huygens lived until the time when Herschel applied his large telescopes to the heavens, few discoveries were made in relation to Saturn. Cassini, in 1671, discovered the fifth satellite of this planet; in 1672, the third; and the first and second in March, 1684. In 1675, Cassini saw the broad side of its ring bisected quite round by a dark elliptical line, of which the inner part appeared brighter than the outer. In 1722, Mr. Hadley, with his five feet Newtonian reflector, observed the same phenomenon, and perceived that the dark line was stronger next the body, and fainter toward the upper edge of the ring. Within the ring he also discovered two belts across the disc of Saturn; but it does not

appear that they had any idea that this dark line was empty space separating the ring into two parts. This discovery was reserved for the late Sir W. Herschel, who made numerous observations on this planet, and likewise ascertained that the ring performs a revolution round the planet in ten hours and thirty minutes.

Of late years, some observers have supposed that the exterior ring of Saturn is divided into several parts, or, in other words, that it consists of two or more concentric rings. The following are some of the observations on which this opinion is founded. They are chiefly extracted from Captain Kater's paper on this subject which was read before the Astronomical Society of London.

The observations, we are told, were made in the years 1825 and 1826, and remained unpublished from a wish on the part of the observer to witness the appearances again. The planet Saturn has been much observed by Captain Kater for the purpose of trying the light, &c., for which the ring and satellites are good tests. The instruments which were employed in the present investigations were two Newtonian reflectors, one by Watson, of 49 inches focus and 6 $\frac{1}{4}$ th aperture, and another by Dollond, of 68 inches focus and 6 $\frac{3}{4}$ ths aperture. The first, under favorable circumstances, gave a most excellent image; the latter is a very good instrument. The following are extracts from the author's journal.

Nov. 25, 1825. The double ring beautifully defined, perfectly distinct all around, and the principal belts well seen. I tried many concave glasses, and found that the image was much sharper than with convex eyeglasses, and the light apparently much greater. Dollond, 259, the best power, 489, a single lens, very distinct. Nov. 30, the night very favorable, but not equal to the 25th. The exterior ring of Saturn is not so bright as the interior, and the interior is less bright close to the edge next the planet. The inner edge appears more yellow than the rest of the ring, and nearer in color to the body of the planet. Dec. 17. The evening extremely fine. With Dollond I perceived the outer ring of Saturn to be darker than the inner, and the division of the ring all around with perfect distinctness; but with Watson I fancied that I saw the *outer ring separated by numerous dark divisions extremely close, one stronger than the rest, dividing the ring about equally*. This was seen with my most perfect single eyeglass power. A careful examination of some hours confirmed this opinion. Jan. 16 and 17, 1826. Captain Kater believed that he saw the divisions with the Dollond, but was not positive. Concave eyeglasses found to be superior to convex. Feb. 26, 1826. The division of the outer ring not seen with Dollond. On the 17th Dec., when the divisions were most distinctly seen, Captain Kater made a drawing of the appearance of Saturn and his rings. The phenomena were witnessed by two other persons on the same evening, one of whom saw several divisions in the outer ring, while the other saw one middle division only; but the latter person was short-sighted, and unaccustomed to telescopic observations. It may be remarked, however, that these divisions were not seen on other evenings, which yet were considered very favorable for distinct vision.

It is said that the same appearances were seen by Mr. Short, but the original record of his observations cannot be found. In Lalande's *Astronomy* (3d edition, article 3351) it is said, "Cassini remarked that the breadth of the ring was divided into two equal parts by a dark line having the same curvature as the ring, and the exterior por-

tion was the less light. Short told me that he observed still more singular phenomena with his large telescope of 12 feet. The breadth of the ansæ, or extremities of the ring, was, according to him, divided into two parts, an inner portion without any break in the illumination, and an outer divided by several lines concentric with the circumference, which would lead to a belief that there are several rings in the same plane." De Lambre and Birt severally state that Short saw the outer ring divided, probably on the authority of Lalande. In Brewster's *Ferguson's Astronomy*, vol. ii, p. 125, 2d edition, there is the following note on this subject: "Mr. Short assures us that with an excellent telescope he observed the surface of the ring divided by several dark concentric lines, which seem to indicate a number of rings proportional to the number of dark lines which he perceived."

In December, 1813, at Paris, Professor Quetelet saw the outer ring divided with the achromatic telescope of ten inches aperture, which was exhibited at the exposition. He mentioned this the following day to M. de la Place, who observed that "those, or even more divisions, were conformable to the system of the world." On the other hand, the division of the outer ring was not seen by Sir W. Herschel in 1792, nor by Sir J. Herschel in 1826, nor by Struve in the same year; and on several occasions when the atmospheric conditions were most favorable, it has not been

seen by Captain Kater. It has been remarked by Sir W. Herschel, Struve, and others, that the exterior ring is much less brilliant than the interior; and it is asked, May not this want of light in the outer ring arise from its having a very dense atmosphere? and may not this atmosphere in certain states admit of the divisions of the exterior ring being seen, though, under other circumstances, they remain invisible? The above observations are said to have been confirmed by some recent observations by Decuppis at Rome, who announced some years ago, that Saturn's outer ring is divided into two or three concentric rings.

Some of the observations stated above, were they perfectly correct, would lead to the conclusion that Saturn is encompassed with a number of rings concentric with and parallel to each other. But while such phenomena as described above are so seldom seen, even by the most powerful telescopes and the most accurate observers, a certain degree of doubt must still hang over the subject; and we must suspend our opinion on this point until future observations shall either confirm or render doubtful those to which we have referred. Should the Earl of Rosse's great telescope, when finished for observation, be found to perform according to the expectations now entertained, and in proportion to its size and quantity of light, we shall expect that our doubts will be resolved in regard to the supposed divisions of the ring of Saturn.

## A P P E N D I X.

### BRIEF DESCRIPTION OF THE EARL OF ROSSE'S TELESCOPE.

This telescope, the largest and most magnificent that ever was attempted, reflects the greatest honor on the genius, the inventive powers, and the scientific acquirements of its noble contriver, as well as on the elevated station in which he is placed. With rank and fortune, and every circumstance that usually unfit men for scientific pursuit, he has set a bright example to his contemporaries of the dignity and utility of philosophical studies and investigations, and of the aids they might render to the progress of science, were their wealth and pursuits directed in a proper channel.

Previously to his lordship's attempting the construction of his largest, or "Monster Telescope," he had constructed one with a speculum of three feet in diameter, which was considered one of the most accurate and powerful instruments that had ever been made, not excepting even Sir W. Herschel's forty feet reflector. In the account of this telescope published in the *Philosophical Transactions* for 1840, his lordship speaks of the possibility of a speculum of six feet in diameter being cast. At that time it was considered by some as little short of a chimera to attempt the construction of such a monstrous instrument; but the idea no sooner occurred to this ingenious and persevering nobleman than he determined to put it to the test, and the result has been attended with complete success. The materials of which this speculum is composed are *copper* and *tin*, united very nearly in their atomic proportions, namely, copper 126.4 parts to tin 53.9 parts.

This compound has a specific gravity of 3.8, and is found to preserve its luster with more splendor, and to be more free from pores than any other. A foundry was constructed expressly for the purpose of casting the speculum. Its chimney, built from the ground, was 18 feet high, and  $16\frac{1}{2}$  square at the base, tapering to four at the top. At each of its sides, communicating with it by a flue, was sunk a furnace 8 feet deep and  $5\frac{1}{2}$  square, with a circular opening 4 feet in diameter. About seven feet from the chimney was erected a large crane, with the necessary tackle for elevating and carrying the crucibles from the furnace to the mold, which was placed in a line with the chimney and crane, and had three iron baskets supported on pivots hung round it; and four feet further on was the annealing oven. The crucibles which contained the metal were each 2 feet in diameter,  $21\frac{1}{2}$  deep, and together weighed one ton and a half. They were of cast iron, and made to fit the baskets at the side of the mold. These baskets were hung on wooden uprights, or pivots; to one of these, on each side, was attached a lever, by depressing which it might be turned over, and the contents of the crucible poured into the mold. The bottom of the mold was made by binding together tightly layers of hoop iron, and turning the required shape on them edgewise. This mold conducted the heat away through the bottom, and cooled the metal toward the top in infinitely small layers, while the interstices, though close enough to prevent the metal from escaping, were suffi-

ciently open to allow the air to penetrate. This bottom was 6 feet in diameter and  $5\frac{1}{2}$  inches thick, and was made perfectly horizontal by means of spirit levels, and was surrounded by a wooden frame. A wooden pattern, the exact size of the speculum, being placed on the iron, sand was well packed between it and the frame, and the pattern was removed. Each of the crucibles containing the melted metal was then placed in its basket, and everything being ready for discharging their contents, they were at the same instant turned over, and the mold being filled, the metal in a short time safely set into the required figure. While it was red hot, and scarcely solid, the framework was removed, and an iron ring connected with a bar which passed through the oven being placed round it, it was drawn in by means of a capstan at the other side, on a railroad, when charcoal being lighted in the oven, and turf fires underneath it, all the openings were built up, and it was left for sixteen weeks to anneal. It was cast on the 13th of April, 1842, at 9 o'clock in the evening. The crucibles were ten hours heating in the furnaces before the metal was introduced, which in about ten hours more was sufficiently fluid to be poured. When the oven was opened the speculum was found as perfect as when it entered it. It was then removed to the grinding machine, where it underwent that process, and afterward was polished, without any accident having occurred.

This speculum weighed *three tons*, and lost about one-eighth of an inch in grinding. Lord Rosse has since cast another speculum of the same diameter four tons in weight. He can now, with perfect confidence, undertake any casting, so great an improvement has the form of mold which he has invented proved. The speculum was placed on an equilibrium bed, composed of nine pieces, resting on points at their centers of gravity. The pieces were lined with pitch and felt before the speculum was placed on them. The speculum box is also lined with felt, and pitched: this prevents any sudden change of temperature affecting the speculum by means of the bad conducting power of the substances employed. A vessel of lime is kept in connection with the speculum box to absorb the moisture, which otherwise might injure the mirror. The process of grinding was conducted under water, and the moving power employed was a steam-engine of three horse power. The polisher is connected with the machinery by means of a large ring of iron, which loosely encircles it; and instead of either the speculum or the polisher being stationary, both move with a regulated speed. The ring of the polisher, and therefore the polisher itself, has a transverse and a longitudinal motion; it makes 80 strokes in the minute, and  $24\frac{1}{2}$  strokes backward and forward for every revolution of the mirror, and at the same time  $1\frac{7}{10}$  strokes in the transverse direction. The extent of the latter is  $\frac{27}{100}$ ths of the diameter of the speculum. The substance made use of to wear down the surface was emery and water: a constant supply of these was kept between the grinder and the speculum. The grinder is made of cast iron, with grooves cut lengthwise, across, and circularly on its face. The polisher and speculum have a mutual action upon each other: in a few hours, by the help of the emery and water, they are both ground truly circular, whatever may have been their previous defects. The grinding is continued until the required form of surface is produced, and this is ascertained in the following manner: there is a high

tower over the house in which the speculum is ground, on the top of which is fixed a pole, to which is attached the dial of a watch; there are trap-doors which open, and by means of a temporary eyepiece, allow the figure of the dial to be seen in the speculum brought to a slight polish. If the dots on the dial are not sufficiently well-defined, the grinding is continued; but if they appear satisfactorily, the polishing is commenced. It required six weeks to grind it to a fair surface. The polisher was cut into grooves, to prevent the abraded matter from accumulating in some places more than in others; a thin layer of pitch was spread over it; it was smeared over with rouge and water, and a supply of it kept up until the machinery brought it to a fine black polish. The length of time employed for polishing the three-foot speculum was six hours.\*

This large telescope is now completed, or nearly so. The tube is 56 feet long, including the speculum box, and is made of deal one inch thick, hooped with iron. On the inside, at intervals of eight feet, there are rings of iron three inches in depth and one inch broad, for the purpose of strengthening the sides. The diameter of the tube is seven feet. It is fixed to mason-work in the ground by a large universal hinge, which allows it to turn in all directions. At 12 feet distance on each side a wall is built, 72 feet long, 43 high on the outer side, and 56 on the inner, the walls being 24 feet distant from each other, and lying exactly in the meridional line. When directed to the south, the tube may be lowered until it becomes almost horizontal; but when pointed to the north, it only falls until it is parallel with the earth's axis, pointing then to the pole of the heavens. Its lateral movements take place only from wall to wall, and this commands a view for half an hour on each side of the meridian; that is, the whole of its motion from east to west is limited to 15 degrees. At present it is fitted up in a temporary way to be used as a transit instrument; but it is ultimately intended to connect with the tube-end galleries machinery which shall give an automaton movement, so that the telescope shall be used as an equatorial instrument. All the works connected with this instrument are of the strongest and safest kind; all the iron work was cast in his lordship's laboratory by men instructed by himself, and every part of the machinery was made under his own eye by the artisans in his own neighborhood, and not a single accident worth mentioning happened during the whole proceeding.

The expense incurred by his lordship in the erection of this noble instrument, was not less than *twelve thousand pounds!* beside the money expended in the construction of the telescope of three feet diameter. Sufficient time has not yet been afforded for making particular observations with this telescope; but from slight trials which have been made, even under unfavorable circumstances, it promises important results. Its great superiority over every telescope previously constructed, consists in the great quantity of light it reflects, and the brilliancy with which it exhibits objects, even when high powers are applied. It has a reflecting surface of 4671 square inches, while that of Herschel's 40 feet telescope had only 1811 square inches on its polished surface,

\* The above description has been selected and abridged from a small volume entitled "The Monster Telescope, erected by the Earl of Rosse, Parsonstown," and also from the "Illustrated London News" of September 9th, 1843. In the volume alluded to a more particular description will be found, accompanied with engravings.

so that the quantity of light reflected from the speculum is considerably more than double that of Herschel's largest reflector. This instrument has already exceeded his lordship's expectations. Many appearances before invisible in the Moon have been perceived, and there is every reason to expect that new discoveries will be made by it in the *Nebulae*, double and triple stars, and other celestial objects. The following is an extract of a communication from Sir James South on this subject, addressed to the editor of the "*Times*;" "The Leviathan telescope on which the Earl of Rosse has been toiling upward of two years, although not absolutely finished, was on Wednesday last directed to the sidereal heavens. The letter which I have this morning received from its noble maker, in his usual unassuming style, merely states that the metal, only just polished, was of a pretty good figure, and that with a power of 500 the nebula known as No. 2 of Messier's catalogue was even more magnificent than the nebula No. 13 of Messier, when seen with his lordship's telescope of three feet diameter and 27 feet focus. Cloudy weather prevented him from turning the Leviathan on any other nebulous ob-

ject. Thus, then, we have all danger of the metal breaking before it could be polished, overcome. Little more, however, will be done with it for some time, as the earl is on the eve of quitting Ireland for England to resign his post at York as president of the British Association. I look forward with intense anxiety to witness its first severe trial, when all its various appointments shall be completed, in the confidence that those who may then be present will see with it what man has never seen before. The diameter of the large metal is six feet, and its focus 54 feet; yet the immense mass is manageable by one man. Compared with it, the working telescopes of Sir William Herschel, which in his hands conferred on astronomy such inestimable service, and on himself astronomical immortality, were but playthings."

The following is a more recent account of observations made by this telescope, chiefly extracted from Sir James South's description, inserted in the *Times* of April 16th, 1845, and the "*Illustrated London News*" of April 19:

"The night of the 5th of March, 1845, was the finest I ever saw in Ireland. Many nebulae were

Fig. 98.

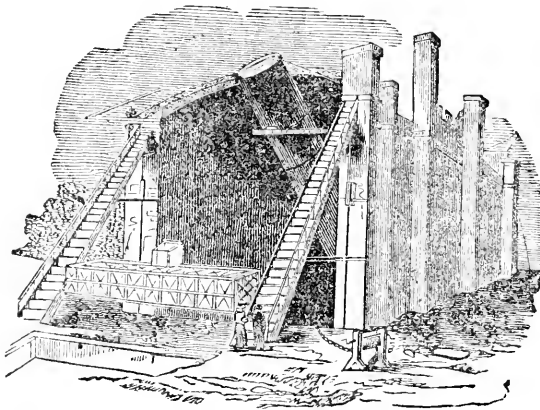

observed by Lord Rosse, Dr. Robinson, and myself. Most of them were, for the first time since their creation, seen by us as groups or clusters of stars; while some, at least to my eyes, showed no such resolution. Never, however, in my life did I see such glorious sidereal pictures as this instrument afforded us. Most of the nebulae we saw I certainly have observed with my own achromatic; but although that instrument, as far as relates to magnifying power, is probably inferior to no one in existence, yet to compare these nebulae, as seen with it and the six-foot telescope, is like comparing, as seen with the naked eye, the dinginess of the planet Saturn to the brilliancy of Venus. The most popularly known nebulae observed this night were the ring nebulae in the *Canes Venatici*, or the 51st of Messier's catalogue, which was resolved into stars with a magnifying power of 548, and the 94th of Messier, which is in the same constellation, and which was resolved into a large globular cluster of stars not much unlike the well-known cluster in Hercules, called also the 13th of Messier." Perfection of figure, however, of a telescope must be tested, not by nebulae, but by its performance on a star of the first magnitude. If it will, under high power, show the star round and free from optical appendages, we may safely take it for granted it will not only show nebulae

well, but any other celestial object as it ought. To determine this point, the telescope was directed to *Regulus* with the entire aperture, and a power of 800, and "I saw," says Sir James, "with inexpressible delight, the star free from wings, tails, or optical appendages; not indeed, like a planetary disc, as in my large achromatic, but a round image resembling voltaic light, between charcoal points; and so little aberration had this brilliant image, that I could have measured its distance from, and position with any of the stars in the field with a spider's-line micrometer, and a power of 1000, without the slightest difficulty; for not only was the large star round, but the telescope, although in the open air, and the wind blowing rather fresh, was as steady as a rock."

"On subsequent nights, observations of other nebulae, amounting to some thirty or more, removed most of them from the list of nebulae, where they had long figured, to that of clusters; while some of these latter, more especially the 5th of Messier, exhibited a sidereal picture in the telescope such as man before had never seen, and which for its magnificence baffles all description. Several double stars were seen with various apertures of the telescope, and with powers between 360 and 800; and as the earl had before told us we should—before the speculum was inserted in

the tube, in consequence of his having been obliged to quit the superintendence of the polishing at the most critical part of the process—we found that a ring about six inches broad, reckoning from the circumference of the speculum, was not perfectly polished, and to that the little irradiation seen about Regulus was unquestionably referrible. The only double stars of the first class which the weather permitted us to examine with it were  $\chi$  Ursæ Majoris, and Gamma Virginis, which I could have measured with the greatest confidence. D'Arrest's comet we observed on the 12th of March, with a power of 400, but nothing worthy of notice was detected. Of the Moon a few words must suffice. Its appearance in my large achromatic of 12 inches aperture is known to hundreds of readers; let them then imagine that with it they look *at* the moon, while with Lord Rosse's six-feet they look *into* it, and they will not form a very erroneous opinion of the performance of the leviathan. On the 15th of March, when the moon was seven days old, I never saw her unilluminated disc so beautifully, nor her mountains so temptingly measurable. On my first looking into the telescope, a star of about the seventh magnitude was some minutes of a degree from the moon's dark limb, and its occultation by the moon appeared inevitable. The star, however, instead of disappearing the moment the moon's edge came in contact with it, apparently glided on the moon's dark face, as if it had been

seen through a transparent moon, or as if the star were between me and the moon. It remained on the moon's disc nearly two seconds of time, and then disappeared. I have seen this apparent projection of a star on the moon's face several times, but from the great brilliancy of the star, this was the most beautiful I ever saw. The cause of this phenomenon is involved in impenetrable mystery.

The following is a representation of the great Rosse telescope, along with part of the buildings with which it is connected. In the interior face of the eastern wall a very strong iron arc of about 43 feet radius is firmly fixed, provided with adjustments, whereby its surface facing the telescope may be set very accurately in the plane of the meridian. On this bar lines are drawn, the interval between any adjoining two of which corresponds to one minute of time on the equator. The tube and speculum, including the bed on which the speculum rests, weigh about 15 tons. The telescope rests on a universal joint, placed on masonry about six feet below the ground, and is elevated or depressed by a chain and windlass; and although it weighs about 15 tons, the instrument is raised by two men with great facility: of course, it is counterpoised in every direction. The observer, when at work, stands in one of four galleries, the three highest of which are drawn out, from the western wall, while the fourth or lowest has for its base an elevating platform, along the horizontal surface of which a gallery slides

Fig. 99

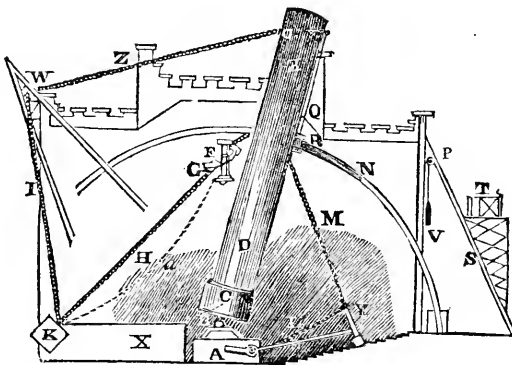

from wall to wall by a machinery within the observer's reach, but which a child may work. When the telescope is about half an hour east of the meridian, the galleries, hanging over the gap between the walls, present to a spectator below an appearance somewhat dangerous; yet the observer, with common prudence, is as safe as on the ground, and each of the galleries can be drawn from the wall to the telescope's side so readily, that the observer needs no one else to move it for him.

The foregoing figure (98) represents only the upper part of the tube of the telescope, at which the observer stands when making his observations. The telescope is at present of the Newtonian construction, and, consequently, the observer looks into the side of the tube at the upper end of the telescope; but it is proposed to throw aside the plane speculum, and to adapt it to the *front view*, on the plan already described (see pp. 88, 89, &c.), so that the observer will sit or stand with his back toward the object, and his face looking down upon the speculum; and in this position he

will sometimes be elevated between 50 and 60 feet above the ground. As yet, the telescope has no equatorial motion, but it very shortly will; and at no very distant day, clockwork will be connected with it, when the observer will, while observing, be almost as comfortable as if he were reading at a desk by his fireside.

The foregoing figure (99) shows a section of the machinery connected with this telescope. It exhibits a view of the inside of the eastern wall, with all the machinery as seen in section. A is the mason work on the ground; B, the universal joint, which allows the tube to turn in all directions; C, the speculum in its tube; D, the box; E, the eyepiece; F, the movable pulley; G, the fixed one; H, the chain from the side of the tube; I, the chain from the beam; K, the counterpoise; L, the lever; M, the chain connecting it with the tube; N, the chain which passes from the tube to the windlass over a pulley on a trussbeam, which runs from W to the same situation on the opposite wall: the pulley is not seen; X is a railroad, on which the speculum is drawn either to or from its

box: part is cut away, to show the counterpoise. The dotted line *a* represents the course of the weight *R* as the tube rises or falls: it is a segment of a circle, of which the chain *I* is the radius. The tube is moved from wall to wall by the ratchet and wheel at *R*; the wheel is turned by the handle *O*, and the ratchet is fixed to the circle on the wall. The ladders in front, as shown in the preceding sketch, enable the observer to follow the tube in its ascent to where the galleries on the side-wall commence. These side-galleries are three in number, and each can be moved from wall to wall by the observer after the tube, the motion of which he also accomplishes by means of the handle *O*.

I shall conclude the description of this wonderful instrument in the words of Sir James South: "What will be the power of this telescope when it has its Le Mairean form [that is, when it is fitted up with the front view], "it is not easy to divine. What nebulae will it resolve into stars? in what nebulae will it not find stars? how many satellites of Saturn will it show us? how many will it indicate as appertaining to Uranus? how many nebulae never yet seen by mortal eye will it present to us? what spots will it show us on the various planets? will it tell us what causes the variable brightness of many of the fixed stars? will it give us any information as to the constitution of the planetary nebulae? will it exhibit to us any satellites encircling them? will it tell us why the satellites of Jupiter, which generally pass over Jupiter's face as discs nearly of white light, sometimes traverse it as black patches! will it add to our knowledge of the physical construction of nebulous stars? of that mysterious class of bodies which surround some stars, called, for want of a better name, 'photospheres'? will it show the annular nebulae of Lyra merely as a brilliant luminous ring, or will it exhibit it as thousands of stars arranged in all the symmetry of an ellipse? will it enable us to comprehend the hitherto incomprehensible nature and origin of the light of the great nebulae of Orion? will it give us, in easily appreciable quantity, the parallax of some of the fixed stars, or will it make sensible to us the parallax of the nebulae themselves? finally, having presented to us original portraits of the moon and of the sidereal heavens, such as man has never dared even to anticipate, will it, by Daguerreotype aid, administer to us copies founded upon truth, and enable astronomers of future ages to compare the moon and heavens as they then may be with the moon and heavens as they were? Some of these questions will be answered affirmatively, others negatively, and that, too, very shortly; for the noble maker of the noblest instrument ever formed by man 'has cast his bread upon the waters, and will, with God's blessing, find it before many days.'"

#### HINTS TO AMATEURS IN ASTRONOMY RESPECTING THE CONSTRUCTION OF TELESCOPES.

As there are many among the lower ranks of the community who have a desire to be possessed of a telescope which will show them some of the prominent features of celestial scenery, but who are unable to purchase a finished instrument at the prices usually charged by opticians, the following hints may perhaps be acceptable to those who are possessed of a mechanical genius.

The lenses of an achromatic telescope may be purchased separately from glass-grinders or opticians, and tubes of a cheap material may be pre-

pared by the individual himself for receiving the glasses. The following are the prices at which achromatic object-glasses for astronomical telescopes are generally sold: Focal length 36 inches, diameter  $2\frac{1}{4}$ th inches, from 2 to  $3\frac{1}{2}$  guineas. Focal length 42 inches, diameter  $2\frac{3}{4}$ ths inches, from 5 to 8 guineas. Focal length 42 inches, diameter  $3\frac{1}{4}$ th inches, from 12 to 20 guineas. Focal length 42 inches, diameter  $3\frac{3}{4}$ ths inches, from 25 to 30 guineas. Eyepieces, from 10s. 6d. to 18 shillings. The smallest of these lenses, namely, that of  $2\frac{1}{4}$ th inches diameter, if truly achromatic, may be made to bear a power of from 80 to 100 times in clear weather for celestial objects, which will show Jupiter's moons and belts, Saturn's ring, and other celestial phenomena. The tubes may be made either of tin plates, *papier maché*, or wood. Wood, however, is rather a clumsy article, and it is sometimes liable to warp, yet excellent tubes have sometimes been made of it. Perhaps the cheapest and most convenient of all tubes, when properly made, are those formed of paper. In forming these, a wooden roller of the proper diameter should be procured, and paper of a proper size, along with bookbinder's paste. About three or four layers only of the paper should be pasted at one time, and when sufficiently dry, it should be smoothed by rubbing it with a smooth stick or ruler; after which another series of layers should be pasted on, and allowed to dry as before, and so on until the tube has acquired a sufficient degree of strength and firmness. In this way I have, by means of a few old newspapers and similar materials, formed tubes as strong as if they had been made of wood. If several tubes be intended to slide into each other, the smallest tube should be made first, and it will serve as a roller for forming the tube into which it is to slide.

An achromatic object-glass of a shorter focal distance and a smaller diameter than any of those stated above, may be fitted up as a useful astronomical telescope when a better instrument cannot be procured. In the pawnbrokers' shops in London and other places, an old achromatic telescope, with an object-glass 20 inches focal distance and about  $1\frac{1}{2}$  inch diameter, may be purchased at a price varying from 15 to 20 shillings. By applying an astronomical eyepiece to such a lens, if a good one, it may bear a power for celestial objects of 50 or 60 times. If two plano-convex glasses three-fourths of an inch focal distance be placed with their convex sides near to each other, they will form an eyepiece which will produce a power on such an object-glass of above 50 times, which will show Jupiter's belts and satellites, Saturn's ring, the solar spots, and the mountains and cavities of the moon. I have an object-glass of this description which belonged to an old telescope, which cost me only 12 shillings, and with which I formerly made some useful astronomical observations. It was afterward used as the telescope of a small equatorial instrument, and with it I was enabled to perceive stars of the first and second magnitude, and the planets Venus, Jupiter, and Mars in the day-time.

But, should such a glass be still beyond the reach of the astronomical amateur, let him not altogether despair. He may purchase a single lens of three feet focal distance for about a couple of shillings, and by applying an eyeglass of one inch focus, which may be procured for a shilling, he will obtain a power of 36 times, which is a higher power than Galileo was able to apply to his best telescope; and consequently, with such an instrument, he will be enabled to perceive all



the celestial objects which that celebrated astronomer first described, and which excited so much wonder at that period in the learned world; but, whatever kind of telescope may be used, it is essentially requisite that it be placed on a firm stand in all celestial observations; and any common mechanic can easily form such a stand at a trifling expense.

There is a certain optical illusion to which most persons are subject in the first use of telescopes, especially when applied to the celestial bodies, on which it may not be improper to make a remark. The illusion to which I allude is this, that they are apt to imagine the telescope does not magnify nearly so much as it really does; they are apt to complain of the small appearance which Jupiter and Saturn, for example, present when magnified 160 or 200 times. With such powers they are apt to imagine that these bodies do not appear so large as the moon to the naked eye; yet it can be proved that Jupiter, when nearest the earth, viewed with such a power, appears about five times the diameter of the full moon, and 25 times larger in surface. This appears from the following calculation: Jupiter, when in opposition, or nearest the Earth, presents a diameter of 47"; the mean apparent diameter of the moon is about 31'; multiply the diameter of Jupiter by the magnifying power, 200, the product is 9400", or 156', or 2<sup>o</sup> 36', which, divided by 31', the moon's diameter, produces a quotient of 5, showing that this planet with such a power appears five times larger in diameter than the full moon to the naked eye, and consequently 25 times larger in surface. Were a power of only 50 times applied to Jupiter when nearest the earth, that planet would appear somewhat larger than the

full moon; for 47" multiplied by 50 gives 2350", or 39', which is 8' more than the diameter of the moon; yet with such a power most persons would imagine that the planet does not appear one-third of the size of the full moon.

The principal mode by which a person may be experimentally convinced of the fallacy to which I allude is the following: At a time when Jupiter happens to be within a few degrees of the moon, let the planet be viewed through the telescope with the one eye, and the magnified image of the planet be brought into contact with the moon as seen with the other eye, the one eye looking at the moon, and the other viewing the magnified image of Jupiter through the telescope when brought into apparent contact with the moon; then it will be perceived that with a magnifying power of 50 the image of Jupiter will completely cover the moon as seen by the naked eye; and with a power of 200—when the moon is made to appear in the center of the magnified image of the planet—it will be seen that Jupiter forms a large and broad circle around the moon, appearing at least five times greater than the diameter of the moon. This experiment may be varied as follows: Suppose a person to view the moon through a small telescope or opera-glass magnifying three times, he will be apt to imagine, at first sight, that she is not in the least magnified, but rather somewhat diminished; but let him bring the image as seen in the telescope in contact with the moon as seen with the naked eye, and he will plainly perceive the magnifying power by the size of the image. It may be difficult, in the first instance, to look at the same time at the magnified image and the real object, but a few trials will render it easy



THE

S O L A R   S Y S T E M :

WITH

MORAL AND RELIGIOUS REFLECTIONS,

IN REFERENCE TO

THE WONDERS THEREIN DISPLAYED.



## P R E F A C E .

---

THE following work is chiefly designed for juvenile readers, and for those who have hitherto acquired but a slender acquaintance with the general facts of astronomical science. With this view, the attention of the reader is, in the first place, directed to the general aspect and the apparent motions of the heavens, in order that he may be induced to contemplate, with his own eyes, the apparent movements of the celestial vault, in all its variety of aspects, as beheld in different countries and at different seasons of the year. Without such observations, the student of astronomy can never acquire a clear and accurate view of the economy of the solar system, and the phenomena it presents; and, therefore, such personal observations are particularly recommended to all the lovers of astronomical science.

This work is a different one from "Celestial Scenery," though in some points there must necessarily be a certain coincidence. The statements of the distances, magnitudes, and general appearances of the planets, must necessarily be the same in both; but the particular descriptions, remarks, and moral and religious reflections, are different. A great variety of subjects likewise is introduced, which are not noticed in "Celestial Scenery," such as the following:—the figure of the Earth—view of its surface, atmosphere, and the method of finding its dimensions—celestial phenomena arising from the annual motion of the earth—the *destination of the earth*, and the final cause of its creation—motions and aspects of the superior planets—general remarks on the solar system—method of acquiring an approximate idea of a million of units—the doctrine of *Eclipses*, with tables and descriptions of the most remarkable eclipses of the sun and moon—descriptions of the seasons of the year, and their characteristics in different countries—Reflections, moral and religious—history of astronomy—explanation of astronomical terms, &c. On these and various other topics, a considerable variety of interesting facts and sketches will be found more or less illustrated.

One great object, which the author has uniformly kept in view, has been to lead the minds of the young from the creature to the Creator, and to direct them to contemplate his attributes as displayed in the motions, magnitudes, and mechanism of the heavens, and to render their views of creation subservient to their moral and spiritual improvement, and to their preparation for a higher sphere of existence—an object which should always be kept in view in our contemplation of the works of God.



# C O N T E N T S .

## I N T R O D U C T I O N .

PAGE.

**OBJECT** and sublimity of Astronomy. Appearance of the heavens to a common observer. Objects of this science lead to sublime and interesting trains of thought—its relation to religion. The Scriptures direct our attention to this subject. It is our duty to contemplate the works of God Plan of the following work.....

## C H A P T E R I .

### ON THE GENERAL ASPECT AND THE APPARENT MOTIONS OF THE HEAVENS.

Preliminary remarks..... 11

### S E C T I O N I .

#### ON THE APPARENT MOTIONS OF THE HEAVENS DURING THE DAY.

**Apparent movements of the sun**, as seen at different seasons, and as viewed from different regions of the globe. Sun's apparent annual motion—how observed. How the motions of the sun appear in Southern latitudes and at the Poles. Stars above the horizon during the day, and may sometimes be seen while the sun is shining..... 11

### S E C T I O N II .

#### ON THE APPARENT MOTION OF THE HEAVENS DURING THE NIGHT.

**General appearance of the starry heavens**—how their apparent motions may be perceived. Aspects of the stars in the southern and in the northern regions of the heavens. Positions of the Great Bear at different seasons. Caution to be observed in making observations. Position of the Pole and the Pole-star. Positions of certain stars and constellations in the beginning of January. Appearance of the stars at the Equator and at the North Pole..... 13

### S E C T I O N III .

#### CONCLUSIONS DEDUCED FROM THE PRECEDING FACTS AND OBSERVATIONS.

**Earth appears sustained between two hemispheres of the heavens.** Rapid and astonishing motions somewhere exist, either in the earth or in the heavens. Reflections on the power of the Deity..... 15

## C H A P T E R II .

### ON THE FIGURE AND MOTION OF THE EARTH.

### S E C T I O N I .

**ON THE FIGURE OF THE EARTH, AND THE ARGUMENTS WHICH PROVE THAT IT IS NEARLY IN THE SHAPE OF A GLOBE.**

Preliminary remarks..... 16  
Opinions formerly entertained on this subject. Four arguments, derived from different sources, particularly illustrated. Argument taken from an eclipse of the moon. Consequences which flow from the globular figure of the earth. It is the best adapted to a habitable world. Discovery of the true figure of the earth, an important fact in the history of Providence..... 17

### S E C T I O N II .

#### ON THE MOTIONS OF THE EARTH.

**Motion actually exists.** Rate of motion in the celestial bodies, were the earth at rest—rate of motion, if the earth move, illustrated by a figure—which of these motions is most probable

and correspondent to the wisdom of the Almighty—a certain rate of motion would shatter the universe to atoms. No instance of a larger body revolving round a smaller. Arguments for the earth's motion derived from the wisdom of the Deity..... 19

SECTION III.

REFLECTIONS SUGGESTED BY THE MOTIONS OF THE EARTH AND HEAVENS.

At what rate we are carried through the regions of space during the hours of sleep, and from one season of the year to another. Rapid motions of the heavens. Original cause of all motion. Scene of wonders which such motions present. Practical instructions deducible from this subject..... 22

CHAPTER III.

DESCRIPTION OF THE SUN, OF THE INFERIOR PLANETS, AND OF THE EARTH AND MOON.

Introductory remarks..... 23

SECTION I.

THE SUN.

Its general appearance and effects in the visible creation. Its magnitude illustrated, compared with other magnitudes. Displays of the glory of the Creator. Nature and physical constitution of the sun. Description of the solar spots—delineation of some of them. Bright solar spots. Conclusions respecting the constitution of the sun. Beneficial effects produced by this luminary—displays the power and beneficence of the Creator—an emblem of the Sun of Righteousness. .... 23

SECTION II.

THE PLANET MERCURY.

Arrangement of the planets in the solar system. Amplitude of their orbits. Orbits of comets. Mercury—its distance, size, and the velocity of its motion—its motion and phases. Quantity of light on its surface—its temperature—orbit elliptical—transits of—is probably inhabited... 27

SECTION III.

ON THE PLANET VENUS.

Its distance, magnitude, motion, rotation, etc. Discoveries made on this planet by the telescope. Galileo and the Senators of Venice. Observations of Cassini. Schroeter's observations and discoveries. Mountains on Venus. Apparent motions of this planet—its superior and inferior conjunctions—description and delineation of its phases—periodical revolution—its transits, etc. Reflections on the morning star, as emblematical of intellectual light and joy..... 30

SECTION IV.

THE EARTH CONSIDERED AS A PLANETARY BODY.

(1.) *General View of the Earth's Surface, Atmosphere, Magnitude, and Method of finding its Dimensions.*

Earth a body which reflects light in common with the other planets—its appearance from the moon. Planets dark bodies in themselves. General aspect of the earth's surface—magnitude of its continents, seas, and oceans—its atmosphere, and the properties with which it is invested. Dimensions of the earth—how ascertained. Its circumference—mode of measuring it. Various measurements of a degree of the meridian..... 33

(2.) *Proofs of the annual Motion of the Earth.*

General considerations which render this motion highly probable. Demonstrative arguments. Arguments derived from the aberration of light. Importance of acquiring correct views on this subject in reference to our conceptions of the Divinity..... 36

(3.) *Phenomena arising from the annual Motion of the Earth.*

The sun will appear to move through the circuit of the heavens. Ecliptic explained. Apparent motion of the sun, as seen from other planets. Why we behold different clusters of stars at different seasons..... 37

(4.) *On the Destination of the Earth, or the final Cause of its Creation.*

Matter exists chiefly for the sake of sentient and intelligent beings. The Creator's design in the formation of man—arrangements made for his happiness—restriction in God's transaction



with him. Fall of man from his state of primitive integrity—the mercy of his Creator displayed. The promised Messiah, and preparations for his advent. Extraordinary events which accompanied the sacrifice he offered. Proclamation of pardon and eternal happiness to the inhabitants of the world. Reasons why this proclamation has been withheld from the majority of the nations. Prospect of the regeneration of the world. Importance of studying the material universe in connection with intellectual beings and moral truths. Population of the earth. Numbers passing daily into the invisible world. Population which the earth is capable of sustaining. Numbers of other living beings. Various other facts respecting the earth. . . . . 39

SECTION V.

ON THE MOON.

Motions of the moon—illustrated by a diagram. Phases and general appearances of this orb. Illustrations of its phases. How the earth appears as seen from the moon. Proofs that the earth shines upon the moon. Appearance of its continents and seas. Moon presents only one side to the earth. Earth appears in a fixed position as seen from the moon. Moon's distance, diameter, and other dimensions. *Telescopic appearances* of the moon—its circular plains—peculiarity of its mountain scenery—its depressions and cavities—its picturesque and sublime scenery—delineation of certain portions of its surface—various astronomical facts in relation to the moon—is probably inhabited—its beauty and utility in relation to our globe. . . . 41

CHAPTER IV.

DESCRIPTION OF THE SUPERIOR PLANETS OF THE SOLAR SYSTEM.

SECTION I.

ON THE MOTIONS AND ASPECTS OF THE SUPERIOR PLANETS.

Distinctions, in seven particulars, of the superior and inferior planets. Apparent motion of the superior planets as seen from the earth. . . . . 47

SECTION II.

ON THE PLANET MARS.

Remarks on its name, and on the atrocity of war—its distance—period of revolution—position in 1845 and 1847—its spots and rotation—inclination of axis—magnitude—telescopic appearance—atmosphere—polar spot—land and water—conclusions respecting its constitution. . . . 43

SECTION III.

ON THE NEW PLANETS.

Their situation in the system—history of their discovery—their magnitudes and distances—their singularities and anomalies—supposed to be the fragments of a larger planet. Reflections suggested by the state in which these planets now exist. . . . . 50

SECTION IV.

ON THE PLANET JUPITER.

Its distance—revolution—magnitude, compared with that of the earth—rotation—rate of motion—inclination of axis—direct and retrograde motions, etc.—present position—telescopic appearance—apparent magnitude with different powers. Its belts—their number and appearance. Conjectures respecting their nature—improbability of their being produced by winds, etc.—different representations of them. Figure of this planet. Quantity of light—its mass, density, etc. . . . . 53

SECTION V.

ON THE SATELLITES OF JUPITER.

History of their discovery—form a system of revolving bodies, analogous to the solar system—their revolutions and eclipses—powers requisite for observing them—table of their magnitudes, periods, etc.—representation of their orbits—their utility in finding the longitude—motion of light—sublime phenomena they present to the inhabitants of Jupiter. Reflections on the sublimity and motion of this planet, and on the Omnipotence of the Deity. . . . . 55

SECTION VI.

ON THE PLANET SATURN.

Its distance and rotation—its motion and present position—telescopic appearance—its magnitude—belts—figure—quantity of light—its satellites, and by whom discovered. Cassini's telescopes—Herschel's. Powers requisite for observing these satellites. Their periods of revolution. Sublime phenomena they present in the firmament of Saturn. . . . . 57

SECTION VII.

ON THE RINGS OF SATURN.

History of their discovery, and conjectures formed respecting the phenomenon. Dimensions of the rings, according to Sir J. Herschel—their solidity and area—their appearance from the

different regions of the planet—four representations of them—their various aspects as viewed through telescopes at different periods—their occasional disappearance—some of the uses or designs for which they are intended. Supposed division of the outer ring. Reflections on their grandeur, and the power of God.....	59
SECTION VIII.	
ON THE PLANET URANUS.	
Former and present supposed dimensions of the solar system. Herschel's telescopes and discoveries. Discovered Uranus—its size and distance—rate of motion—quantity of light and heat. Its satellites—their period and distance—direction of their motions.....	62
SECTION IX.	
GENERAL REMARKS ON THE SOLAR SYSTEM.	
Whether other planets may exist within its range. Order and harmony which prevail in the system—unity and mutual relationship of the bodies which compose it. Unity of the Supreme Being. Illustrations of the distances and magnitudes of the planets. Summary view of the solar system.....	63
METHOD OF ACQUIRING AN APPROXIMATE IDEA OF A MILLION OF UNITS.      in	
Difficulty of forming an accurate conception of such a number. Various illustrations. Method suggested by Mr. Martin of Chatham, illustrated by a figure. Incomprehensible nature of the universe, as to distances and magnitudes, etc.....	65
CHAPTER V.	
ON COMETS.	
Meaning of the term. How comets are distinguished from planets—length of their tails, and opinions respecting them. Form of their orbits. Account of some remarkable comets. Comets of 1807 and 1811. Gambart's and Encke's comets. Numbers of comets. Opinions respecting them in former ages. Whether they may come in contact with the earth. Destination of comets.....	66
CHAPTER VI.	
ON THE ECLIPSES OF THE SUN AND MOON.	
Opinions respecting eclipses in former times. Nature of an eclipse, and the different kinds of them.	69
SECTION I.	
ON THE ECLIPSES OF THE MOON.	
Cause of lunar eclipses. In what circumstances they happen. Figures representing the nature of lunar eclipses. Facts in relation to them. Their duration etc.....	69
SECTION II.	
ON THE ECLIPSES OF THE SUN.	
Nature of a solar eclipse, and when it happens. Explanation of a diagram illustrative of solar eclipses. Various facts in relation to solar eclipses. Periods of eclipses. Darkness which accompanied our Saviour's Crucifixion must have been supernatural. Account of a total eclipse of the sun. Description of the phenomena which accompanied the total eclipse of 1724, as seen in England. Total eclipses which will happen in future years. Description of a total eclipse of the sun, at Vienna, in July, 1842. Table of solar eclipses during the present century. Utility of eclipses.....	71
CHAPTER VII.	
ON THE SEASONS, AND THE DIFFERENT LENGTHS OF DAYS AND NIGHTS.	
Succession of day and night. Seasons in the frigid, temperate, and torrid zones. Characteristics of the different seasons. Description of spring—of summer—of autumn—of winter. Seasons produced by the operation of simple principles. Change of seasons illustrated by a diagram. General remarks. Why our weather is coldest when the sun is nearest us. Such seasons as we now enjoy are not the same as in the primeval state of man. Various moral reflections in relation to the seasons.....	74
CHAPTER VIII.	
REFLECTIONS. MORAL AND RELIGIOUS, IN REFERENCE TO THE SOLAR SYSTEM.	
Astronomy presents to view objects calculated to excite solemn reflections, and to raise our views to the Great Creator. 1. The solar system exhibits a striking display of Almighty power. This power, thus displayed, lays a foundation for the hope and comfort of the Christian. 2. This system displays the wisdom and benevolence of the Creator. Various instances of wisdom and goodness. 3. The facts it exhibits have a tendency to moderate the pride of man, and to promote humility. The wisest and most exalted beings in the universe are characterized by humility. Scriptural declarations respecting it. 4. Astronomy affords a striking view of the condescension of God. 5. The studies connected with astronomy tend to prepare the renewed spirit for the employments of the future world. Moral and spiritual dispositions requisite. The first step to eternal felicity. The course to be prosecuted in order to be fitted for Heaven—the blessed effects of prosecuting this course.....	79
APPENDIX.	
I. New discoveries in the planetary system, 85.—II. Brief sketch of the history of astronomy, 83.—III. Explanation of astronomical terms, 90.—IV. The telescope, 93.	

# THE S O L A R   S Y S T E M .

## I N T R O D U C T I O N .

Of all the sciences which are the subject of human study and investigation, Astronomy must be admitted to be the most interesting and sublime. It teaches us the motions, the magnitudes and distances of the heavenly bodies—their diversified phenomena, the laws by which they are directed in their varied movements, and the grand designs they are intended to fulfill in the vast system of the universe.

The objects with which this science is conversant are so grand and marvelous—surpassing everything that could have been imagined in the infancy of science—that they tend to enlarge the field of human contemplation, to expand to an indefinite extent the conceptions of the human intellect, and to arouse the attention and excite the admiration even of the most incurious and uncultivated minds. The vast magnitude of the heavenly bodies, so far surpassing what could be conceived by their appearance to the unassisted eye; their incalculable numbers; the immense velocity of their motions, and the astonishing forces with which they are impelled in their career through the heavens; the attractive influence they exert upon each other, at the distance of hundreds of millions of miles; and the important ends they are destined to accomplish in the universal empire of Jehovah; present to the human imagination a scene, and a subject of contemplation, on which the soul of man might expatiate with increasing wonder and delight, during an indefinite series of ages.

Even to a common observer, the heavens present a sublime and elevating spectacle. He beholds an immense concave hemisphere of unknown dimensions, surrounding the earth in every region, and resting as it were upon the circle of the horizon. From every quarter of this vast expanse—when the shades of night have spread over the earth—he beholds numerous lights displayed, proceeding onward in solemn silence, varying their aspects at different seasons, moving with different degrees of velocity, shining with different degrees of splendor, and all calculated to inspire admiration and awe. Wherever he travels abroad, either on the surface of the land or of the ocean, this celestial vault still appears encompassing this lower world; and, after traveling thousands of miles, it appears still the same, and seems to make no nearer an approach than when the journey commenced. While contemplating this wonderful expanse with the eye of reason and imagination, the mind is naturally led into a boundless train of speculations and inquiries. Where do these mighty heavens begin, and where do they end? Can imagination fathom their depth, or human calculations, or figures, express their extent? Have the highest created

beings ever winged their flight across the boundaries of the firmament? Can angels measure the dimensions of those heavens, or explore them throughout all their departments? Is there a boundary to creation beyond which the energies of Omnipotence are unknown, or does it extend throughout the infinity of space? Is the immense fabric of the universe yet completed, or is Almighty Power still operating throughout the boundless dimensions of space, and new creations still starting into existence?

Such views and inquiries have a tendency to lead the mind to sublime and interesting trains of thought and reflection, and to afford scope for the noblest energies and investigations of the human intellect. A serious contemplation of the heavens opens to the mental eye a glimpse of orbs of inconceivable magnitude and grandeur, and arranged in multitudes which no man can number, which have diffused their radiance on our world during hundreds of generations. It opens a vista which carries our views into the regions of infinity, and exhibits a sensible display of the immensity of space, and of the boundless operations of Omnipotence: it demonstrates the existence of an eternal and incomprehensible Divinity, who presides in all the grandeur of his attributes over an unlimited empire. Amidst the silence and the solitude of the midnight scene, it inspires the soul with a solemn awe, and with reverential emotions; it excites astonishment, admiration, and wonder, and has a tendency to enkindle the fire of devotion, and to raise the affections to that ineffable Being who presides in high authority over all the movements of the universe. It teaches us the littleness of man, the folly of pride and ambition, and of all that earthly pomp and splendor with which mortals are so enamored—and that our thoughts and affections ought to soar above all the sinful pursuits, and transitory enjoyments, of this sublunary scene.

Such being the views and the tendencies of this science, it ought to be considered as bearing an intimate relation to religion, and worthy the study of every enlightened Christian. It has been said, and justly, by a celebrated poet, that “An undevout astronomer is mad.” The evidence of a self-existent and eternal Being, whose wisdom is inscrutable, and whose power is uncontrollable, is so palpably manifested in the arrangement and the motions of the celestial orbs, that it cannot but make an indelible impression on every rational and reflecting mind. Though the heavenly bodies have “no speech nor language,” though they move round the earth in silent grandeur, and “their voice is not heard” in articulate sounds, yet “their line is gone throughout all the earth, and their words to the

end of the world"—proclaiming to every attentive spectator, that "The hand that made them is Divine." So that there is scarcely a tribe or nation on the face of the earth, so inattentive and barbarous as not to have deduced this conclusion from a survey of the movements of the celestial orbs. "Men," says Plato, "began to acknowledge a Deity, when they saw the stars maintain so great a harmony, and the days and nights throughout all the year, both in summer and winter, to observe their stated risings and settings." Another heathen philosopher, Cicero, thus expresses his sentiments on this point: "What can be so plain and clear as, when we behold the heavens, and view the celestial bodies, that we should conclude there is some Deity of a most excellent mind by whom these things are governed—a present and Almighty God. Which, he that doubts of, I do not understand why he should not as well doubt whether there be a sun that shines, and enlightens the world."

The sacred Scriptures, in numerous instances, direct our attention to this subject. "The heavens," says the Psalmist, "declare the glory of God;" that is, they manifest his wisdom and power, and beneficence to the inhabitants of the world;—"the firmament showeth forth," or publicly declareth, "his handiwork." "Day unto day uttereth speech, and night unto night showeth knowledge. There is no speech nor language where their voice is not heard." In reference to that department of creation which astronomy explores, it may be said with peculiar propriety, in the language of Scripture, "The works of the Lord are great, sought out of all them that have pleasure therein." Throughout the volume of inspiration, our attention is frequently directed to the contemplation of the heavens: "Lift up thine eyes on high, and behold who hath created these things.—The everlasting God, the Lord, the Creator of the ends of the earth, who fainteth not, neither is weary; there is no searching of his understanding.—He bringeth out their host by number, and calleth them all by names: by the greatness of his might, for that he is strong in power; not one faileth.—It is he that sitteth upon the circle of the earth, and the inhabitants thereof are as grasshoppers.—All nations before him are as nothing; and they are counted to him less than nothing, and vanity."—"Hearken unto this, O Job: stand still, and consider the wondrous works of God."

Hence it appears, that it is not to be considered merely as a matter of taste, or as a rational amusement, but as an imperative duty, to contemplate the works of the Most High, and especially the manifestations of his power and Godhead which the heavens display—that we may derive more enlarged conceptions of his glorious attributes, and be enabled to render to him that tribute of adoration and praise which is due to his name. For it is represented as one of the

characteristics of the ungodly, that while "the harp, and the viol, and the tabret, and pipe, and wine are in their feasts,—they regard not the work of the Lord, neither consider the operation of his hands;" and consequently "he will destroy them, and not build them up." It is therefore the incumbent duty of the young; of every professing Christian; and of every rational inquirer, not only to study the facts, doctrines, and duties exhibited in the system of Divine revelation, but also to contemplate the manifestations of the Creator as exhibited in the system of creation. They are both revelations of the same almighty and beneficent Being—emanations from the same adorable Divinity; and the views and instructions they respectively unfold, when studied with reverence and intelligence, are in perfect harmony with each other. The study of both combined, is calculated to make the man of God perfect, and "thoroughly furnished unto all good works."

In the following small volume, it shall be our endeavor to direct the general reader in the study of some of those objects which the heavens unfold; and we shall chiefly select those parts of astronomical science which are most level to the comprehension of those who have had little opportunity of engaging in scientific pursuits. In the present volume, it is proposed to confine ourselves chiefly to a description of the Solar System, and the phenomena it exhibits, together with a few instructions as to the best mode of contemplating the apparent motions and the diversified aspects of the firmament. The discoveries which relate to the sidereal heavens—the general arrangement of the fixed stars, their distances and magnitudes—the facts which have been discovered respecting new stars—variable stars—double and triple stars—the Milky Way—the different orders of the nebulae—and a variety of other topics connected with such objects, will form materials for another volume similar to the present.

In the meantime we may just remark, that all the wonders we behold, both in the heavens above, and in the earth below, demand our serious attention and devout contemplation. They are all the workmanship of that great and adorable Being in whom "we live and move;" who at first "spoke, and it was done;" who gave the command, and the whole of this stately fabric of heaven and earth started into being. It is the same God who created the planets and the host of stars, and that conducts them in all their rapid motions; who is also "the God and Father of our Lord Jesus Christ," and "the Author of eternal salvation" to all who obey him. All these works display his infinite power, his unerring wisdom, and the riches of his beneficence; and demand from every beholder that tribute of praise, reverence, and adoration which is due to Him "who created all things, and for whose pleasure they are and were created."

## CHAPTER I.

### ON THE GENERAL ASPECT, AND THE APPARENT MOTIONS OF THE HEAVENS.

PREVIOUS to entering on the study of astronomical science, and the phenomena of the solar system, it is requisite that the young inquirer should be directed to contemplate the general aspect of the heavens, and the apparent motions of the different bodies which present themselves to view in the regions of the firmament. No one can enter with intelligence on the study of astronomy, or acquire an accurate idea of its elementary principles, and of the arrangement and motions of the planetary bodies, unless he has been led to observe, with his own eyes, the apparent and more obvious phenomena and aspects of the celestial orbs, as they present themselves to the view of any common and attentive spectator. For although the real motions of the heavenly bodies are, in many instances, very different from their apparent movements, and although many of them appear to move while they are absolutely at rest, yet it is necessary that their apparent motions and appearances should be accurately inspected, in order that, in the progress of investigation, we may be enabled to determine what bodies are really in motion, and what only appear to be in motion, in consequence of the motions of other bodies. In order to direct the untutored observer on this point, the following observations are stated.

#### SECTION I.

##### ON THE APPARENT MOTIONS OF THE HEAVENS DURING THE DAY.

IN the first place, let us consider the appearance of the heavens as seen in the day-time. Sometimes it happens for days, and even for weeks together, that the sky is overcast with an assemblage of sable clouds covering the whole face of the firmament. In which case no celestial orb makes its appearance; but the light transmitted through the clouds and reflected from their under surfaces, indicates that some luminous orb, the fountain of light, is above our horizon, and far beyond the upper region of the clouds, though its form and splendor cannot be perceived. At other times the concave of the sky appears of an azure color, where scarcely a speck of cloud is to be seen—like a boundless desert, where no celestial orb makes its appearance—as at the dawning of the morning, when the aurora makes its appearance in the east. This faint light gradually increases, rising higher and higher in its brightness, a prelude of something still more grand and magnificent. The clouds near the horizon are tinged with purple and vermilion, and the mountain tops are clothed with brightness. At length, the disc of the sun disengages itself from the horizon by degrees, until the whole of his orb appears to view, and ascends the heavens with majestic grandeur. The sun is the only object which, during the day, appears conspicuous to the naked eye;

for although the moon is frequently visible in the day-time, yet she then appears with no greater brilliancy than a small cloud of the same size, and is scarcely noticed by a common observer.

The apparent movements of the sun appear very different at different seasons of the year, and in different regions of the globe. In describing these apparent motions, we shall suppose ourselves, in the first instance, in the latitude of fifty-two degrees north, which is nearly the latitude of London and several other large towns in England. The sun's apparent motions in this latitude will be nearly the same as when he is viewed from Holland, Denmark, Scotland, Nova Scotia, Canada, and the northern states of America. Suppose we begin our observations in winter, about the 21st December, when the days in our northern hemisphere are shortest. In this case, turning our eyes to the south-east quarter of the sky, a little after eight o'clock in the morning, we shall see the sun rising nearly on the south-eastern point of the compass, and gradually ascending the celestial vault. In about four hours, he comes to the meridian, or due south, the highest point of his elevation at that season; after which he gradually descends toward the west, and sets in the south-western part of the heavens, about four in the afternoon, having described a comparatively small arc of a circle above the horizon. At this time, when he arrives at the meridian, or the highest point of his diurnal course, he is only about fourteen degrees above the horizon.\* If, after this period, the point at which the sun rises be observed, it will be found a little to the northward every day, from the point at which he rose before. On the 21st of March, the sun rises due east, about forty-five degrees to the north of the point at which he rose on the 21st of December. The time of his rising is exactly six in the morning; six hours afterward, he passes the meridian, at an elevation of thirty-eight degrees; and sets due west, at six o'clock in the evening. At this time, the day and the night are of an equal length, namely, twelve hours each.

If again we view the rising sun on the 21st of June, we shall find that he rises near the north-east, forty-five degrees farther to the northward than on the 21st of March. At this period, the sun describes a large circuit around the heavens; rising fifteen minutes before four in the morning, and advancing to an elevation of more than sixty degrees at noon-day; after which he declines toward the west and sets near the north-west

\* The circumference of the heavens, as well as that of the earth, is divided by astronomers into three hundred and sixty parts called degrees; consequently, the distance from the horizon to the zenith, or the point directly above our heads, is ninety degrees, or the one-fourth of the circumference of a circle. When, therefore, the sun is said to be elevated above the horizon fourteen degrees, it means, that he has risen to an altitude little more than the one-sixth part of the distance from the horizon to the zenith. The apparent breadth of the sun or moon is a very little more than half a degree.

quarter of the heavens, about a quarter past eight in the evening. The length of the day, at this time, is about sixteen and a half hours; and as his course during the night is not far below the horizon, there is no absolute darkness during the absence of the sun; and his course may be traced by observing the motion of the twilight, or the aurora, gradually proceeding to the northern point of the heavens, and from that point to the north-east, where the solar orb again emerges from the horizon. After this period, the sun begins, every succeeding day, to rise in points nearer the south, and to take less extensive circuits round the heavens, until the 23d of September, when he again rises on the eastern point of the horizon, and sets in the west, which is the time of the autumnal equinox, when day and night are equal. From this period the sun gradually verges to points of the horizon south of the east, at the time of his rising, and the days rapidly shorten, until he again arrives near the south-eastern quarter of the heavens, where he is seen to rise on the 21st of December. Such are some of the apparent motions of the sun, in our quarter of the globe, throughout the different seasons of the year; and every one who resides in the country has an opportunity, every clear day, of observing these diversified movements.

Beside the motions to which we have now adverted, there is another apparent motion of the sun, in a contrary direction, which is seldom noticed by a common observer. Every day the sun has an apparent motion from west to east, at the rate of nearly a degree each day; and in the course of a year, or 365 days, 5h. 48m., and 51s., he makes a complete circuit around the heavens. This motion manifests itself chiefly by the appearance of the heavens during the night. If, in the morning, some time before sunrise, we view those stars which are near the point of the horizon where the sun rises, in a week or two, we shall find that the same stars are more elevated near the time of sun-rising than before, and farther distant from him, indicating that he is moving through the heavens toward the east, and leaving these stars as it were behind him. If, again, in the evening, we mark those stars which are a little above the point of the setting sun, we shall find that every evening they make a nearer approach to the place where the sun goes down; until, after a short period, they approach so near this luminary as to be overpowered by his rays, and can no longer be seen, still indicating that the sun is approaching toward the east.

Perhaps the best way of tracing this is to mark the different positions of the Pleiades, or seven stars, with respect to the sun. About the middle of January, at eight o'clock in the evening, the seven stars are seen nearly on the meridian, which observation should be noted down for the purpose of being compared with future observations. On the 1st of March, at the same hour, these stars will be seen nearly halfway between the meridian and the western horizon, while all the other stars, at the same elevation, will be found to have made a similar progress. About the 15th of April, they will be seen, at the same hour, very near the north-western horizon; and every day after this, they will appear to make a nearer approach to that part of the heavens in which the sun appears, until, being overpowered by the splendor of his rays, they cease to be visible. From these and similar observations, it will be easily perceived that the sun has an apparent motion through the circle of the heavens, and that the revolution is completed in the course of a year. The circle which the

sun thus describes is called the **ECLIPIC**, and is divided into twelve signs, and three hundred and sixty degrees.

The apparent motions of the sun appear somewhat different, when viewed from different regions of the earth. Were we placed in countries under the equator, such as at Borneo, Sumatra, the Gallipago isles, Quito, and other parts of South America, the sun at noon would shine directly from the zenith, at the time of the equinoxes, at which time objects would have no shadows. At all other times the sun will appear either in the northern or the southern quarter of the heavens. During the one half of the year, he shines from the north, and the shadows of objects fall to the south: during the other half, he shines from the south, and the shadows of objects are projected to the north; a circumstance which can never occur in our country, or in any part of the temperate zones. At the equator, too, there is a perpetual equality of days and nights throughout the year; the twilight is shortest, and the darkness of night rapidly succeeds the setting of the sun.

Were we placed in southern latitudes—for example, at the Cape of Good Hope, New South Wales, or Buenos Ayres, in South America—in- stead of beholding the sun moving along the southern part of the heavens, from the left hand to the right, as in our country, we should see him directing his course along the northern part of the sky, from the right hand to the left. In other respects, his apparent motions would nearly resemble those already described, excepting that when the sun is highest at mid-day to us, he appears lowest to the inhabitants of these countries; their winter happening at the time of our summer. Were we placed in Lapland, Greenland, or other countries within the polar circle, the sun, in winter, would be absent for weeks and even for months together; and in summer he would shine without intermission for a corresponding portion of time; appearing every day to make a complete circle round the heavens, but never descending below the horizon during the lapse of six weeks or even three or four months. Could we suppose ourselves placed at the north pole, the motion of the sun would present a different aspect from any of those now described. On the 21st of March, we should see a portion of the sun's disc appear in the horizon after a long night of six months. This portion of the sun would appear to move quite round the horizon every twenty-four hours; it would gradually rise higher and higher until the whole orb of the sun made its appearance. As the season advanced the sun would appear to rise higher and higher, until on the 21st of June, he attained the altitude of twenty-three and a half degrees above the horizon; after which his altitude would gradually decline until the 23d of September, when he would again appear in the horizon. During the whole of this period of six months, there is perpetual day; the stars are never seen, and the sun appears to go quite round the heavens every twenty-four hours without setting, in circles nearly parallel with the horizon.

Such are some of the motions and aspects of the sun, as viewed at different seasons of the year, and from different parts of the earth. Let it be carefully remembered that these motions are not real, but only apparent. While presenting all these diversified aspects and movements to spectators placed in different positions, it can be proved that the sun is, notwithstanding, a quiescent body in the center of the planetary system. By the rotation of the earth round its axis from west to east every twenty-four hours, and by its revolution

round the sun every year, all the apparent motions we have hitherto described are produced, and completely accounted for, as we shall afterwards show, when we come to illustrate the evidences which prove that the earth on which we dwell is a moving body.

When we view the sun pursuing his course through the heavens in a clear and serene sky, we are apt to imagine that there are no other celestial bodies diffusing their rays above our horizon. This, however, is far from being the case. In the full blaze of day, there are as many stars, at an average, around us in the firmament, as are beheld in a clear sky at the hour of midnight; but their light is overpowered by the more brilliant splendor of the sun. By means of equatorial telescopes, which can be made to point to any particular part of the heavens, all the larger stars of the firmament may be seen even at noonday, while the sun is shining in all his splendor; nay, there is scarcely a star visible to the naked eye, during night, but may be seen in this way during the blaze of day, and its exact position in the heavens pointed out. During a total eclipse of the sun, when the moon interposes her dark body between us and the sun, some of the planets and the larger stars have appeared as distinctly as at midnight; but the moment the moon has passed a little over the disc of the sun, and a glimpse of his beams has shone out, their feeble light becomes undistinguishable, and they are no longer perceived. Sometimes, too, it happens that stars have been seen from the bottom of deep wells and mines, when large ones happen to pass near the zenith during the day, and the planet Venus, when brightest, has frequently been seen with the naked eye, in the day-time when at no great distance from the sun. Thus it appears that the sun passes through the heavens every day with stars all around him, although invisible to the unassisted eye—just as the moon, during night, is seen surrounded with stars, which the faintness of her light is not sufficient to overpower.\* Hence it happens that astronomers can trace the exact path of the sun among the stars every day, during his apparent annual circuit round the heavens. They can tell what stars are near and around the sun; what clusters he is leaving behind him, to what other clusters he is approaching; what stars or planets are near his margin, and what stars are behind his luminous globe, with as much accuracy as if they were all visible to the naked eye, as at midnight.

## SECTION II.

### ON THE APPARENT MOTIONS OF THE HEAVENS DURING NIGHT.

When a careless observer, on a clear evening, gazes upon the firmament, he beholds a number of shining points, some of them far more brilliant than others, dispersed throughout every region of the sky; but he cannot tell whether they appear to move or to remain in a fixed position; whether they shift their positions with respect to each other; whether they rise and set; whether all the stars visible at six o'clock in the evening are also

\* The author has frequently seen, by the equatorial telescope, in the day-time, not only numerous stars of the first, second, and third magnitudes, in regions of the firmament at a distance from the sun, but has perceived the planet Venus, when immersed in the sun's effulgence, and when it was within a degree of the margin of that luminary.

seen at midnight, or whether the same clusters are to be seen in summer as in winter. There are thousands and millions of mankind who have occasionally gazed on the starry vault who could give no reply to such interrogations. Such is the apathy with which the most wonderful works of God are viewed by the great bulk of mankind; although only a few days or hours of serious observation would be sufficient to solve some of the questions to which we allude.

In order to illustrate the apparent motions of the heavens, let us suppose ourselves placed in a situation which commands an extensive view of the sky, about the beginning of January, at eight o'clock in the evening. At this period, on a serene evening, when the sky is destitute of clouds, a sublime and beautiful spectacle presents itself to view, as some of the most brilliant constellations are then above the horizon. We behold a vast hemisphere expanding over our heads, whose center we seem to occupy, and which appears to rest upon our horizon. Above and around us, on every hand, a multitude of brilliant orbs, of various degrees of splendor, display their radiance. But whether they are in motion or at rest, does not appear at the first glance. We must make different observations, and wait for some time until their motion, or rest, be discovered. To ascertain this point, let us fix on a particular star, or a cluster of stars, and bring it in contact with a church spire, a chimney top, the twig of a tree, or any elevated object, and our line of vision, and in a short time we shall find it has moved onward to the west, while we have remained stationary in our position. Or, if we direct a common telescope to any star, and fix the instrument in one position, in a few minutes the star will have passed from the field of view to the westward. If we look at a star near the horizon in the west, in a few minutes it will sink beyond the limits of our view, and disappear. If we mark any particular star just risen above the eastern horizon, in an hour or two it will be seen considerably elevated above its former position, and every minute rising higher and higher. If we look at any bright star rising due east about six o'clock in the evening, at twelve, midnight, it will be on the meridian, or due south, at an elevation of thirty-eight degrees, and at six o'clock next morning, it will be seen setting at the western point of the horizon. In like manner, any other star rising toward the east, north-east, or south-east, if carefully observed, will be found to rise gradually until it come to the meridian, and then decline in a western direction, until it set either in the west, north-west, or south-west. If it rise in the north-east, it will set in the north-west, and if it rise in the south-east it will set in the south-west; in the former case describing a larger, and in the latter, a lesser portion of a circle, in the sphere of the heavens.

The following are some varieties which may be observed in the apparent motions of the stars. If you look toward the south, you will observe some stars just appearing above the horizon, grazing this circle, as it were; but not rising above it, and then vanishing. If you observe a group a little to the east of the south, you will find them rising above the horizon, making a small arch, and then going down a little to the west of the meridian. If you mark another group rising much farther to the east, you will find these describing a much larger arch, and taking a much longer time before they go down to the westward of the meridian. If you now turn your face to the northern part of the sky, you will find some stars that just skim the horizon, at certain times, near the north point,

and then gradually mount up to the top of heaven, until they come nearly over head, and then descend, and again nearly touch the northern horizon; and ascend again without ever disappearing, describing a complete circle above the horizon. Such are the bright stars Vega, Capella, and several others. Other stars that are higher than these, when seen near the northern horizon, likewise describe complete circles in the sky, without approaching the horizon; and these circles gradually diminish, until at last you arrive at a star which seems scarcely to move from the point where it is stationed—all the rest seeming to circulate around it as a center. This is called the Pole Star, which, to a common observer, never seems to vary its position; and, in the latitude we have supposed, is elevated more than fifty degrees above the northern horizon. The time occupied by the stars now alluded to, in completing their circles, is about twenty-four hours, or, more accurately, is twenty-three hours, fifty-six minutes, and four seconds, and they all finish their revolutions in exactly the same period of time.

For the illustration of what has been now stated, let us suppose ourselves to be viewing the northern quarter of the heavens, about the beginning of November, at eight o'clock in the evening. At this time, the Great Bear, or *Ursa Major*, will appear near the lowest part of its course, not far from the northern part of the horizon. I refer to this constellation, because it is generally known, even to common observers, and is sometimes distinguished by the names of "the Plough," and of "Charles's Wain." That part of the constellation which is generally recognized, consists of seven bright stars, of which the four toward the right form a kind of irregular square, and the three stars stretching out from it to the left form a kind of irregular curve. In the following figure (fig. 1), this constellation is represented in four positions.

Fig. 1.

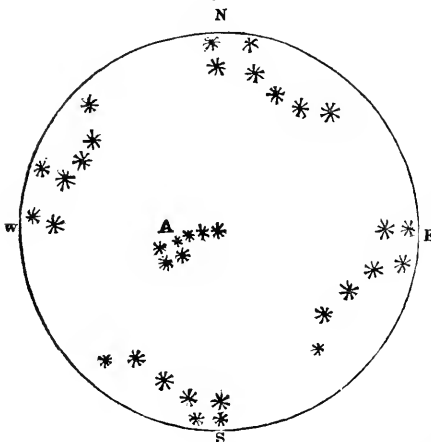

Immediately above the letter S, in the lower part of the figure, are two stars, forming the right side of the square, the uppermost of which is called Dubbe, and the lower one Merak. They are about five degrees distant from each other, and are most frequently known by the name of "the Pointers," because they always point toward the pole-star. The pole-star is represented in the central part of the figure; it is about twenty-nine degrees—or nearly six times the distance of the

two pointers—from Dubbe, and in whatever position this constellation may happen to be, these two stars always point to the pole-star, which is the first bright star in a line with the pointers, at the proportional distance exhibited in the engraving; and by attending to this circumstance, the pole-star may at all times be distinguished. Such is the position of this constellation at eight o'clock in the evening of the 1st of November. If now we view this constellation, about eleven o'clock the same evening, or a few evenings afterward, we shall find that it has moved considerably toward the east, and to a higher elevation; and at two o'clock the next morning, it will be seen in the position represented at E, with the pointers still directed to the pole-star. At eight o'clock in the morning, it will be seen at N, when it will appear in the zenith, with the pointers pointing downward toward the pole. At two o'clock in the afternoon, if it could then be seen, it will appear as represented at W, to the west of the pole, and the pointers pointing eastward to the polar star; and again, about eight in the evening it will return nearly to its former position at S.

Again, this constellation appears in different positions, at the same hour, at different seasons of the year. We have seen that, in the beginning of November, at eight o'clock in the evening, it appears as represented at S; in the beginning of February, at the same hour, it will appear as represented at E; in the beginning of May, as exhibited at N; and in the beginning of August, at the same hour, as represented at W.

In order that none of my readers may fall into any mistakes, from what has been now stated, I may be permitted to mention the following anecdote:—A few years ago, I pointed out in the heavens, to a lady of my acquaintance, the constellation of the Great Bear, and showed her how she might mark its positions at different times, and its apparent revolution round the pole-star. About a year afterward, she told me she had carefully made the observations to which I had directed her, and found them to correspond to what I had stated. She appeared, however, to have paid no attention to any other stars, but those of the Great Bear; and on putting several questions to her on the subject, I found that she conceived of the motion of the Great Bear as if it had been a huge monster pursuing its way through the midst of the surrounding stars, as if they had all been at rest, without apparently shifting their position—somewhat like a huge animal pursuing its way through a crowd, whilst every individual of the crowd remained nearly in the same position. Now, that my readers may not fall into the same mistake, let it be carefully remembered that all the stars in the neighborhood of the pole have the same apparent motions and revolutions as the Great Bear, all moving in concert, but some of them describing larger, and others smaller circles, around the polar point, and all completing their revolution in the same time, namely, in twenty-four hours.

Having represented the pole-star in the center of the engraving, to prevent mistakes, it may be proper to mention, that this star, although, to a common observer, it appears in a fixed position, is not exactly in the polar point: it is at present one degree and thirty-two minutes from the north pole of the heavens, and revolves around it every day in a circle of about three degrees in diameter. This motion may be perceived by placing a telescope in a fixed position, and directing it to this star, when we shall find that, after an hour or two, it will have moved out of the field of view



There is no star exactly at the polar point, and this is called the polar star, because it is the nearest bright star to the north pole of the heavens. It forms the tip of the tail, or the extremity, of *Ursa Minor*, or the Lesser Bear, which likewise consists of seven stars, arranged very nearly in the shape of the Greater Bear, but in a reverse order. This constellation, which is much nearer the pole than *Ursa Major*, may be seen revolving around it, in the same manner as we have described above, but the stars of which it is composed are much smaller, and not so easily distinguished as those of *Ursa Major*. When the Great Bear is at its lowest position, as at S (fig. 1), the square of the Lesser Bear is considerably to the westward, and the four stars, of which it is composed, are directly above the tail of the Great Bear, at the distance of about twenty degrees, as at A.

Let us now suppose ourselves contemplating the southern, eastern, and western parts of the heavens, about the beginning of January, at nine o'clock in the evening. At this time we shall see the seven stars, a very little to the west of the meridian, and at a very high elevation. Next to this cluster, on the east, but a little lower, is *Aldebaran*, or the Bull's Eye, a ruddy star of the first magnitude, in the constellation of Taurus. South by east of *Aldebaran*, and considerably below it, is the splendid constellation of Orion, distinguished by four bright stars forming an irregular square, or parallelogram, in the middle of which are three bright stars in a straight line, at equal distances from each other. This is one of the most splendid constellations in the heavens, and is distinguished by almost every common observer by the three stars now mentioned, which form the belt of Orion, or what Job calls "the bands of Orion," and are sometimes known by the names of "the three Kings," "the Yard," and "the Lady's Elwand." South-east from Orion, at a low elevation, is the star Sirius, belonging to *Canis Major*, or the Great Dog, which is considered the most brilliant fixed star in the heavens. North-east from Sirius, at a higher elevation, is Procyon, a bright star in *Canis Minor* or the Little Dog. North from Procyon, at a much higher altitude, are the bright stars Castor and Pollux, belonging to the constellation Gemini. If, then, three hours after having made these observations, or about midnight, we view the face of the heavens, we shall find a considerable alteration in the positions of the stars and constellations to which we have referred. The seven stars will then be found to have moved halfway between the meridian and the western horizon, followed by *Aldebaran*, which is then a considerable distance past the meridian to the westward. The constellation Orion is likewise westward of the meridian, and the bright star Sirius, which was formerly in the south-east, is now nearly due south. Procyon, and Castor and Pollux, which, at nine o'clock, were a great way toward the east, are, at midnight, not far from the meridian, and at a much higher elevation. All which circumstances show that the various clusters of stars, in the eastern, southern, and western portions of the heavens, have a regular and uniform apparent motion from east to west.

Such are some of the general appearances of the heavens, as viewed in our northern latitude; but, in several other quarters of the globe, their aspects will appear somewhat different. Were we placed under the equator, in the island of Sumatra, or about Quito, in South America, we should behold all the stars in the firmament proceeding in their courses from east to west. All

the stars would appear to rise and set, and none of them would describe circles above the horizon, as some of them appear to do in our northern region. The north pole, which in our latitude, is at a high elevation, would appear in the northern point of the horizon, and the south pole would, at the same time, be visible in the opposite quarter of the heavens. In our latitude, we cannot perceive above two-thirds of the stars which may be seen in the firmament; but, at the equator, all the visible stars of heaven may be perceived. During the space of twenty-four hours they all pass along above the horizon. The one-half of them, indeed, cannot be seen on account of the light of day, but, in the course of a year, they are all visible. Were we placed in Van Dieman's Land, or at the Cape of Good Hope, we should behold multitudes of stars which are never visible in our latitude, and the constellations of the Great and Little Bears, Cassiopeia, and other clusters, would be no longer visible. Could we take our station at the north pole of the earth, the stars would appear neither to rise or set, nor yet to stand still. All the stars visible from this point would appear to move round the heavens above the horizon, in parallel circles, every twenty-four hours; and all that could ever be seen in such a situation might be perceived every hour and minute, in a clear sky, when the sun is absent. But, from this point, only one-half of the firmament is visible, and none of the stars belonging to the other half ever rise above the horizon.

### SECTION III.

#### CONCLUSIONS DEDUCED FROM THE PRECEDING FACTS AND OBSERVATIONS.

AN intelligent spectator, after having observed the various aspects of the heavens above described, will naturally inquire—Whence come those stars which are seen gradually emerging from the eastern horizon? Whither have those stars gone which have sunk beneath the western horizon? And what becomes of those stars during the light of day, which shine with so much splendor during the shades of night? A little reflection on the subject will soon suggest, that the stars which are seen rising above the eastern horizon, come from another hemisphere of the heavens, which is invisible from the point on which we stand, and which we are apt to imagine is below the hemisphere which we behold above us; and when they set in the west, return to that hemisphere again; and that the reason why the stars are not visible during the day, is because their light is overpowered by the more vivid splendor of the sun. We are also naturally led to conclude, from such appearances, that the world in which we dwell is suspended in empty space, and is surrounded on all sides, above and below, by the expanse of the firmament, in which the sun, moon, planets, and stars appear to perform their diversified motions and revolutions. Another conclusion which may be deduced from the preceding observations, is, that the whole sphere of the heavens performs an apparent revolution round our world; carrying, as it were, all the stars along with it in the space of twenty-four hours. Whether this motion be real, or only apparent, requires to be determined by certain rational considerations, and from the harmony and order which appear to be characteristic of the works of the Creator; to which subject we shall particularly direct our attention in the following chapter.

In the meantime, we may remark, that such general views of the motions of the starry firma-

ment as we have already taken, have a tendency to expand the intellectual faculties, and to elevate the mind to the contemplation of some Great Invisible Power, by which such mighty movements are conducted. When we behold the vast concave of the sky, with all its radiant orbs, moving in majestic grandeur around our globe, an idea of sublimity and almighty energy irresistibly forces itself upon the mind, which throws completely into the shade the mightiest efforts of human power,—so that the most stupendous machines ever constructed by human art can afford no assistance in forming a conception of that incomprehensible Power, which sustains and carries forward in their course thousands of spacious worlds. The shining orbs which the firmament displays are evidently placed at an immense distance from the earth, and consequently are bodies of an immense size; and if the apparent motions to which we have adverted were real, the swiftness with which they would fly through the regions of space would exceed all human calculation and conception. But whether these motions be real or apparent, we find motions actually existing among the orbs of heaven which astonish and overpower every rational and contemplative mind. The very circumstance, that motions so sublime appear in the expanse of the firmament, is a demonstrative proof that motions of a wonderful and incomprehensible nature exist somewhere; and the ideas of majesty, of grandeur, and of omnipotent energy, which this single circumstance is calculated to inspire, are such as irresistibly to lead the mind to the contemplation of a Being whose perfections are incomprehensible, and whose “ways are past finding out.”

It does not require a scientific knowledge of astronomy in order that the mind may be impressed with sentiments of admiration at the movements which appear throughout the universe. For the works of God, when contemplated in any point of view, or on any theory, or hypothesis we may form, appear, like himself wonderful, magnificent, and incomprehensible. The motions to which we have chiefly alluded, are either in the earth or in the heavens. If these motions really exist in the heavens, the mind is overpowered with astonishment at the idea of thousands and tens of thousands of vast globes of light, at immense distances, every day revolving around us with amazing velocity. If the motion chiefly exist in the earth, then we are still overwhelmed with wonder at the idea of a globe containing two hundred millions of square miles, with its mighty continents and oceans, and its numerous population, whirling around its axis every day, at the rate of a thousand miles an hour, and in its course round the sun, flying with a velocity of eleven hundred and thirty miles every minute! There is no alternative but that of admitting either the one or the other of these motions; and whatever view we take of this subject, or in whatever light we contemplate the phenomena of the heavens, we are almost irresistibly led to exclaim, “Great and marvelous are thy works, Lord God Almighty!” “Who can utter the mighty operations of Jehovah!” “The Lord God omnipotent reigneth!” The idea of a Being who thus incessantly displays such amazing energies demands from all his intelligent offspring a tribute of reverence and adoration, of gratitude and praise.

## CHAPTER II.

### ON THE FIGURE AND MOTION OF THE EARTH.

#### SECTION I.

ON THE FIGURE OF THE EARTH, AND THE ARGUMENTS WHICH PROVE THAT IT IS NEARLY IN THE SHAPE OF A GLOBE.

In the preceding chapter, we have given a description of the principal motions which appear in the heavens, both by day and by night. Every one, however illiterate, who has a desire to study “the wonderful works of God,” has an opportunity, if he please, to observe most of the motions and phenomena to which we have adverted, provided he live in the country, or in a spacious street or square. Those who live in the narrow and dirty lanes and courts of London, Liverpool, Manchester, and other populous cities and towns, have no scope for making such observations, unless they occasionally retire to the open fields; and hence it is that the inhabitants of such places seldom know anything of the general aspects either of the earth or of the heavens. It is, however, the incumbent duty of every man, and particularly of every Christian, to contemplate, with an eye of intelligence and devotion, the operations of the Most High, in order that he may be enabled to “praise Him for his mighty acts,” and “according to his excellent greatness.” And the man who will not give himself the trouble of occasionally devoting an hour or two to such studies and observations, virtually

declares that the works of his Creator are unworthy of his contemplation; and consequently, that he deserves to remain in ignorance of the most sublime objects of creation, and of the most glorious manifestations of the Divinity.

Before proceeding to a particular description of the planetary system, it is requisite that we should acquire clear and definite views of the figure and motions of this earth, on which we reside; without which the general frame of the universe, and the order and arrangement of the solar system, cannot be appreciated or understood.

For a long period, during the dark ages, and the infancy of science, the world in which we dwell was considered as the largest body in the universe. It was supposed to be an immense plain, diversified with a few inequalities, caused by the mountains and vales; and that it stretched out in every direction to an unlimited extent, and was bounded on all sides by the sky. What was below this immense mass of land and water, and how it was supported, none could tell; though some of the Christian fathers strenuously asserted that the earth was extended infinitely downward, and established upon several foundations. Such were the absurd and foolish opinions of those who viewed the system of nature through a false medium, and who were ignorant of the facts and

principles of modern science. It is only within the period of the last three hundred years that the true figure and dimensions of the earth have been accurately ascertained. This figure is now found to be that of an oblate spheroid, very nearly approaching to the shape of a globe, or sphere. That this is in reality the form of our world will appear from the following considerations.

1. When, on a calm day, we take our station on the sea-shore, we shall perceive that the surface of the water is not quite plane, but a little convex, or rounded; and if we happen to be on one side of an arm of the sea, two or three miles broad, if we place our eyes near the water, and look toward the opposite coast, we shall plainly see the water elevated between our eyes and the opposite coast, so as to prevent our seeing the objects which are near the edge of the water. If we make the same experiment on a lake of two or three miles in extent, a small boat near the end of the lake may be seen by a man who is at some height above the water; but if we lay our eye near the surface, the view of the boat will be intercepted by the convexity of the water, which shows that the lake is a small segment of a globe.

2. When we view a ship taking its departure from the coast in any direction, as it retires from our view we may perceive the masts and rigging of the vessel when the hull has disappeared, and has sunk, as it were, beyond the boundary of our sight. First we lose sight of the hull, then of the sails, and, last of all, of the topmast. On the other hand, when a ship is approaching the shore, the first part of it which is visible, when at a considerable distance, is the topmast; as it approaches nearer, the sails begin to be seen; and last of all the hull gradually comes within the limits of our sight—but the vessel will pass over several miles of the sea, from the time of our first perceiving the topmast until the hull appears. In order to make such observations with accuracy, it is requisite that a telescope should be used. What is it, then, that prevents the hull of a ship from being perceived when its topmasts are visible? It is evidently the round, or convex surface of the water rising up, as it were, or interposing between our eye and the lower part of the ship, when it has receded a certain distance. Now, as such appearances are observed on every sea and ocean on the face of the earth, it follows that the ocean at large is a convex surface, or a portion of a globe; and if the ocean be globular, so also is the land—notwithstanding that the hills and mountains form a few inequalities on its surface—for the portions of the land are all

nearly on a level with the ocean, with the exception of the ranges of elevated mountains.

What has been now stated may be illustrated by the following figure (fig. 2), in which the convex surface of the globe is represented. At D a person is represented as standing on the top of a tower; and from that elevation he is enabled to see both the topmast and the hull of the ship E; which is evident, because right lines can be drawn without interruption from the eye, both to the topmast and to the hull. Whereas a line drawn from the eye to the hull of the ship F, which is at a greater distance, is intercepted by the convex surface of the water interposing, and consequently the hull is invisible; but a line drawn from the eye to the higher parts of the vessel shows that the topmasts are visible, because light, when passing through the same medium, flows in straight lines from every object. In conformity with what has been now stated, we find that the higher the eye is placed, the farther will the view be extended. From a lofty mountain we obtain a much more distant and extensive prospect than from the plain below; and hence it is common for sailors to ascend to the top of the ship's mast, when they wish to descry objects at the greatest distance; as from such an elevation they can discover land, or other ships, at a greater distance than when they stand on deck.

Fig. 2.

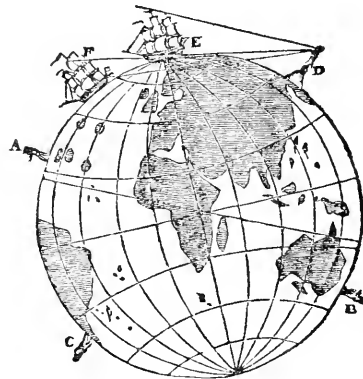

On the other hand, were the surface of the sea a level plain, as represented in fig. 3, the appearances would be very different. A line might be drawn from any object situate upon it, as the

Fig. 3.

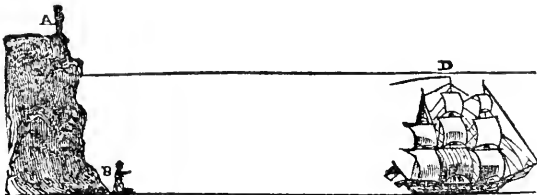

ship D, to the eye, whether it were placed high or low, at A or at B. In this case, any object upon the earth or sea would be visible at any distance which was not so great as to make the appearance of it too faint or small to be perceived. An object would be visible at the same distance

whether the eye were high or low. The largest, and not the highest, objects would be visible at the greatest distance. The topmast of a ship would first disappear, and the hull, as being the largest body, would be longest visible; but this is contrary to all experience. The considera-

tions now adduced are, therefore, clear and decisive proofs that the earth is not an extended plain, but a globular body; and it is astonishing that such a conclusion was not generally drawn until a few centuries before the present age.

3. That the earth is round from east to west, appears from actual experiment; for many navigators, by sailing in a westerly direction, have gone quite round it from east to west. They have set sail from England, crossed the Atlantic, rounded Cape Horn, sailed along the Great Pacific ocean to the northern coasts of New Holland, crossed the Indian sea, and passing the Cape of Good Hope, have again arrived, by traversing the Atlantic, to the port whence they set out. This experiment therefore shows that the earth is round from east to west; but it does not prove that it is also round from north to south; for it has never been actually circumnavigated in that direction, on account of the obstruction caused to navigation by the immense masses of ice within the polar regions. Had we therefore no other proof of the earth's rotundity than this, we might be apt to suppose it somewhat resembling the shape of a cylinder. But that the earth is in reality round from north to south, appears from the following circumstances. When we travel a considerable distance from north to south, or from south to north, a number of new stars successively appear in the heavens in the quarter to which we are advancing, and many of those in the opposite quarter gradually disappear. For example, in sailing toward the south, when we approach the equator the brilliant constellation called the Cross makes its appearance, which is

always invisible in this country; and if we go still farther south, the constellations of the Great Bear, Cassiopeia, and other stars visible in our northern sky, will entirely disappear; which could not happen if the earth were a plane in that direction; for, in this case, all the stars of heaven would be visible in every point from the north pole to the south.

4. Another corroborative proof of the earth's globular figure is this: in cutting for a canal, in order to have the water on a level, certain allowances require to be made for the earth's rotundity. The slope requisite to be made on this account is about eight inches in the mile, thirty-two inches in two miles, and so on, increasing as the square of the distance. If the earth were a plane, no allowances of this kind would be requisite, in order that the water in a long canal might stand on a level.

5. The phenomena exhibited in eclipses of the moon present to the eye a clear demonstration that the earth is of a spherical form. It is well known that an eclipse of the moon is produced by the intervention of the body of the earth between the sun and the moon, which can only happen at the time of full moon, in which case, the shadow of the earth falls upon the moon. This shadow is found in all cases, and in every position of the earth and moon, to be of a circular figure, or the segment of a circle, as the whole shadow cannot be seen at one time. Thus, let A B [fig. 4] represent the moon while an eclipse is going on, and C D the shadow of the earth, which is much larger than the diameter of the moon. In every stage of the progress of an

Fig. 4.

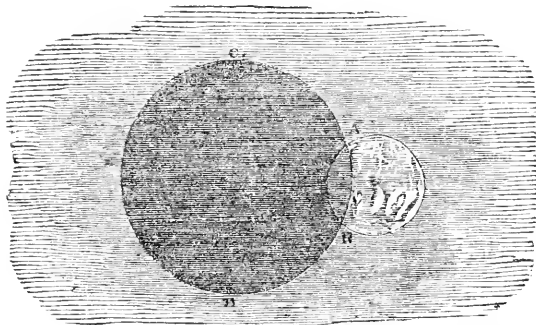

eclipse, the curve A B of the earth's shadow is distinctly perceived passing along the disc of the moon. But the entire shadow of the earth is not seen, because there is no bright object on which the whole of it can fall; only that part of it which covers the moon being visible. But since this shadow always appears a portion of a circle, it proves, incontestably, that the whole mass of land and water, of which the earth is composed, is nearly of a globular form.

If, therefore we admit that the earth is of a globular form, it necessarily follows that it may be inhabited on all sides, and consequently, that those who live on the opposite side of the globe must have their feet pointing toward our feet, and their heads pointing in an opposite direction. Thus, in fig. 2, the person standing at A has his feet pointing to the feet of the one standing at B, and their heads pointing to regions of space directly opposite; and therefore if by any motive power, they were to

be carried forward in the direction to which their heads point, and the power to be continued, they would never meet through all eternity. The same may be said in reference to the persons supposed to be placed at C and D. It also follows, that, could we suppose a hole bored through the center of the earth, commencing at the point where we now stand, and extending to the opposite side, it would terminate at our *antipodes*, and would measure nearly eight thousand miles. It likewise follows that this globe of land and water is either suspended in empty space, or is moving round its axis every day, or flying with immense velocity round the sun every year. Whichever of these suppositions we hold to be true, a wonderful and sublime idea is conveyed to the mind. If we suppose the earth at rest in empty space, we have presented to view a globe—containing 264 millions of cubical miles, and weighing at least, 2,200,000,000,000,000,000,000, or more than two thousand

trillions of tons—resting upon nothing—suspended in the midst of infinite space, and surrounded by the immense bodies of the universe, with no material support but the invisible arm of Omnipotence, poising its immense mass of continents and oceans, and preventing it from sinking into the depths of infinity. If we suppose it to be turning round its axis, and revolving at the same time, round the sun, then we have presented to view a still more astonishing idea—a globe, of the huge dimensions now stated, with its numerous population, flying through the spaces of immensity, without intermitting its speed a single moment, at the rate of sixty-eight thousand miles every hour. So that there is no view we can take of the works of the Almighty, in which we are not irresistibly excited to wonder and admire.

We may here also remark, that the globular figure of the earth is evidently the best adapted to a habitable world. It is the most capacious of all forms, and contains the greatest quantity of area in the least possible space. It is the best adapted to motion, both annual and diurnal, every part of the surface being nearly at the same distance from the center of gravity and motion. Without this figure, there could have been no comfortable and regular alternation of day and night in our world, as we now enjoy; and the light of the sun and the mass of waters could not have been equally distributed. Had the earth been of the figure of a cube, or pentagon, or of any other angular form, some parts would have been comparatively near the center of gravity, and others hundreds or thousands of miles farther from it. Certain countries would have been exposed to furious tempests, which would have overturned and destroyed every object; while others would have been stifled for want of currents and agitation of the air. One part would have been overwhelmed with water, and another entirely destitute of the liquid element; one part might have enjoyed the benign influence of the sun, while another might have been within the shadow of elevations a hundred miles high, and in regions of insufferable cold. In short, while one country might have resembled a paradise, others would have been transformed into a chaos, where nothing was to be seen but barrenness and desolation. But the globular figure which the Creator has given to our world prevents all such inconveniences and evils, and secures to us all the advantages we enjoy from the equable distribution of light and gravity—of the waters of our seas and rivers, and of the winds and motions of the atmosphere. Hence it is that all the bodies of the planetary system are either spherical, or spheroidal bodies; nay, all the great bodies in the universe, so far as our knowledge extends, are found to be of a globular figure; and in this arrangement the wisdom and intelligence of the Almighty Creator are clearly to be perceived.

In short, the discovery of the globular figure of the earth constitutes an important fact in the history of Divine Providence, without which some of the grand designs of the Creator, in reference to our world, would not have been accomplished. It was in consequence of a knowledge of this fact that the continent of America was discovered, and the blessings of civilization, science, and Christianity conveyed to that region of the earth. On a knowledge of the true figure of the earth the art of navigation depends: and in consequence of this, the greater part of the world has been explored, and the way prepared for carrying the tidings of salvation to men of all nations, through faith in the crucified Redeemer. On the knowledge of the true figure of the earth depends our know-

ledge of its magnitude and dimensions; and on our knowledge of its magnitude, depends our knowledge of the distances of the sun and moon; and on our knowledge of the distance of the sun depends our knowledge of the respective distances of the planets, and the extent of the solar system; and on our knowledge of the extent of this system, depend our conceptions of the distances of the fixed stars, and of the vast magnitude and extent of the material creation; and on our views of the immensity of the universe, depend the enlarged conceptions we are now enabled to form of the attributes of that Almighty Being from whom we derived our existence, and whose "kingdom ruleth over all." Had the first link of this chain—our knowledge of the figure of the earth—been wanting, we should have remained in ignorance of all the important consequences, now stated, which have resulted from this discovery—so intimately connected are all the branches of useful knowledge, both human and Divine.

Had mankind always remained ignorant of this important fact, the circumnavigation of the globe would never have been attempted; vast portions of the habitable world would have remained unknown and unexplored; the intercourses which now subsist among the various tribes and nations of mankind could not have been carried on; the tribes of the greater portion of the heathen world, and the countries in which they reside, would have been unknown; no extensive missionary enterprises could have been carried forward; the knowledge of "the salvation of God" could not have been communicated to all the nations that dwell upon the face of the earth, according to the predictions of ancient prophecy; and our ideas of the majesty and grandeur of the great Creator and Redeemer of men would have remained as low and contracted as in the dark ages, when it was considered, even by ecclesiastics, as a heresy and a crime to maintain that the earth is round like a globe, or ball, and that it may be inhabited on all sides. But now, in consequence of the knowledge we have acquired on this subject, the way is prepared for the accomplishment of the Divine purposes and predictions in relation to our race; our knowledge of creation and the perfections of its Author, is extended; the path to future improvement and discovery is laid open, and everything now appears, notwithstanding many obstacles, to be hastening onward to a glorious consummation.

## SECTION II

### ON THE MOTIONS OF THE EARTH.

It is presumed that, in the times in which we live, there are few persons who have any doubts that the world in which we dwell is nearly of the figure of a globe, especially when this position can be proved by so many sensible demonstrations. But there are still many who can scarcely be convinced that it is moving along with immense velocity through the regions of space, in company with the other planets. On this subject, therefore, we shall now offer a few considerations, tending to prove that the world we inhabit—however steadfast it may appear to the eye of sense—is, in reality, a moving body, and that all its inhabitants are carried forward with a velocity far greater than any motions we see around us. There are two different motions considered as connected with the earth:—one, by which it is viewed as turning round its axis every twenty-four hours: and another, by which it wings its flight round the sun

once every year. In the meantime, I shall chiefly illustrate those arguments by which its diurnal motion may be demonstrated.

1. In the first place, there is one thing of which we are all certain, that motion does actually exist, either in the earth, or in the heavens. We every day behold the sun apparently moving from the eastern toward the western horizon. We find, likewise, all the stars in the firmament apparently moving in a body round the earth, in the course of twenty-four hours, and in the manner described in the preceding pages. Such observations, which every one has it in his power to make, clearly show, that there is motion somewhere, and the question is—Does this apparent motion really exist in the heavens, or is it the motion of the earth that produces this appearance? Let us suppose, for a moment, that it is the earth which moves. What, then, will be the rate of its motion, in turning round its axis, to produce the apparent revolution of the heavens? For, if the earth really move round its axis from west to east, the heavens will, of course, appear to revolve around us from east to west. The rate of this motion will depend upon the magnitude of the earth. Now, we know that the earth is a globe, somewhat more than 24,000 miles in circumference; and, consequently in turning round every twenty-four hours, some portions of its surface must move at least a thousand miles every hour. This is a motion far more rapid than has ever been produced in the smallest bodies by human art; and, therefore, it may appear incredible to some that such a motion can exist in a globe of such vast dimensions as the earth. But, if such persons deny that the earth thus moves, then they *must admit* that the heavens move. There is no alternative; for motion actually exists, either in the one or in the other. Now, if the motion is to be considered as existing in the heavens, let us consider what the rate of this motion must necessarily be. If a small globe of 18 inches diameter, were supposed to perform a revolution round its axis in two seconds, and a globe of 2000 yards, or 72,000 inches in diameter, to finish a rotation in the same time, this larger globe would move with a velocity four thousand times greater than the other. In fig. 5, if A B, in the center represent the earth, then

Fig. 5.

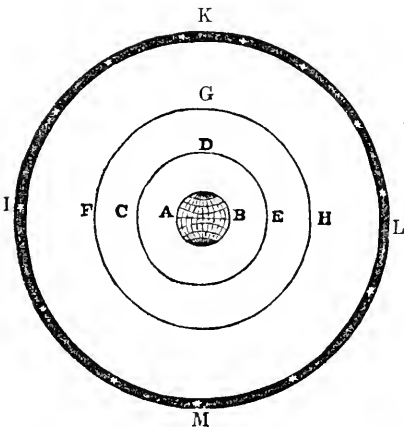

if the circle C E revolve round it in a certain time, and the other two circles revolve around it in the same time, it is evident that the circle F H must revolve with a quicker motion than the cir-

cle C E, and the circle I L with a still greater velocity in proportion to its greater distance from the center of motion, A B.

Let us consider, then, what would be the rate of motion of some of the bodies in the heavens, whose distance from the earth is known. The sun is ascertained to be ninety-five millions of miles distant from the earth, and, consequently, were he to move round the earth every day, as he appears to do, he would move along a circumference of 597 millions\* of miles every day; that is, at the rate of above twenty-four millions of miles in an hour, 414,000 miles in a minute, and 6900 miles every second. Again, the planet Uranus, at its nearest distance from the earth, is more than 1700 millions of miles distant; and consequently the circumference of its orbit is more than ten thousand six hundred millions of miles. If therefore this planet were supposed to move round the earth every day, its motions would be at the rate of 445 millions of miles in an hour,—seven millions four hundred and twenty thousand miles in a minute,—and one hundred and twenty-three thousand six hundred and seventy-seven miles every second. Again, the nearest fixed stars are known not to be within 20,000,000,000,000, or twenty billions of miles from the earth; and consequently their daily circuit round our globe would measure more than 125,000,000,000,000, or one hundred and twenty-five billions of miles; that is, at the rate of fourteen hundred millions of miles in the space of a single second, or the interval of time which the pendulum of a common clock takes in moving from one side to the other! Stars, at distances a hundred times greater—of which there are many such in our firmament—would move with a rapidity a hundred times swifter; and those still farther removed from us in the depths of immensity, with a velocity far exceeding either human or angelic comprehension; yet all the stars of heaven appear to move round our globe every twenty-four hours. If the circle C D E (fig. 5) represent the supposed diurnal orbit of the sun; F G H that of Uranus; and I K L M that of some of the fixed stars; then it is evident, that in proportion to the distance of the body from the earth will be the velocity of its motion, if it be supposed to move round the earth every day.

If, therefore, there be any reader disposed to reject the motion of the earth, because it appears incomprehensible, he must necessarily admit of motions ten hundred thousand times greater and far more incomprehensible, more especially when we consider that the bodies in the heavens to which we have alluded are incomparably greater than this globe of earth on which we stand,—the planet Uranus being more than eighty times, and the sun more than thirteen hundred thousand times larger than the earth, and the fixed stars, at an average, as large as the sun. Such a rate of motion, in such a number of magnificent luminaries, appears altogether overwhelming, and, I may add altogether incredible.

The question then which we have to decide is, which of the motions to which we have referred is most probable—the motions of the earth, or of the heavens? Is it really necessary that the whole

\* If the circle C D E represent the circle which the sun apparently describes in revolving round the earth, P C, its distance from the center of the earth, represent 95,000,000 of miles, and the diameter of the circle C E 190,000,000; and, as the proportion of the diameter of a circle to its circumference is nearly as 7 to 22, the circumference of the sun's circle, C D E will be about 597,000,000 of miles, through which he behooved to travel every day, if the earth were at rest.

universe, composed of sun, moon, planets, comets, stars, and nebulae, should move round our globe with such astonishing velocities, in order to produce the alternate succession of day and night? Reason tells us that it is not. We know that the Almighty does nothing in vain, but employs the most simple means, in order to accomplish the most astonishing and important ends. The succession of day and night can be accomplished by a simple rotation of the earth on its axis, which will completely account for all the apparent diurnal revolutions of the celestial bodies. This we find to be actually the case with the other planets of the solar system. The planet Jupiter is fourteen hundred times larger than the earth, and moves round its axis in less than ten hours, at the rate of 28,000 miles an hour, which is a velocity twenty-eight times greater than that of the earth, supposing it to move round its axis. The planet Saturn is nearly a thousand times larger than our globe, and it revolves round its axis in ten hours and a half, at the rate of 24,000 miles an hour, in those places situate near its equator. To a spectator placed on these planets, the heavens would appear to revolve around him every ten hours, as they appear to us to revolve every twenty-four hours, but with an apparently more rapid motion; while he himself might suppose, as we are apt to do, that he is actually at rest. The earth, therefore must be considered as revolving round its axis, in accordance with the arrangements of the other planets of the system to which it belongs; and to suppose otherwise, would be in opposition to all the laws which govern the material universe, and would distort all our ideas of the harmony and order of the works of the Creator.

2. Another consideration which demonstrates the diurnal motion of the earth is this: that such a rate of motion in the heavenly bodies, as has now been stated, though it might be within the limits of Divine power to effect, *would soon shatter the material universe to atoms*, and reduce creation to a chaos. Were a ball of soft wood to be projected from a cannon, at the rate of 800 miles per hour, in a few moments it would be reduced to splinters; and hence the forage and other light substances projected from a piece of ordnance are instantly torn to pieces. What then might be supposed to be the consequences, were a body impelled through the ethereal regions with a velocity of a hundred thousand millions of miles in a minute, as multitudes of the stars behooved to be, were the earth at rest in the center of the universe? It would undoubtedly reduce to atoms the most compact bodies in creation, although they were composed of substances harder than adamant.

3. Another corroborative argument in support of the motion of the earth is this, that *there is no instance known in the universe of a larger body revolving around a smaller*. We do not find such planets as Jupiter and Saturn revolving around their satellites, or moons; but all those satellites which are much smaller than these planets, perform their revolutions around them, as the center of their motions. The earth, which is fifty times greater than the moon, does not revolve around her, but that nocturnal luminary regularly revolves around the earth. The sun does not revolve around the planets Mercury and Venus—which are thousands of times less than that luminary—but they invariably revolve around him as the center of light and influence. As the sun is one million three hundred thousand times larger than the earth, it cannot therefore be supposed for a moment, that such an enormous globe should re-

volve, with such an inconceivably rapid motion, around so inconsiderable a ball as the earth; and much less that the whole universe should revolve around it every day. Were the earth not revolving around its axis every day, there would be an infraction of all the laws which govern the system of universal nature; and therefore it is absolutely necessary to admit its motion, in order to direct our views, and to produce conviction of the unity of design, and of the harmony of creation.

4. The last argument I shall mention in the meantime, and which I consider as demonstrative on this subject, is this—that if the earth were at rest, and all the heavenly bodies revolving around it with dreadfully rapid motions, *it would confound all our ideas of the wisdom and intelligence of the Deity*. Wisdom is that perfection of an intelligent agent, which enables him to proportionate one thing to another, and to devise the most appropriate means to accomplish important ends. We should reckon that person foolish in the extreme who should construct, at an enormous expense, a huge piece of machinery for carrying round a grate, and the body of a large building to which it is attached, for the purpose of roasting a small fowl, fixed in the center of its motions; instead of making the fowl turn round its different sides to the fire. Were the inhabitants of London or any large town, to attempt to construct machinery to make the whole city move round in a circle, carrying a lamp near the center to throw light and heat over a ball of only one inch in diameter, when the same purpose could have easily been effected by making the ball itself turn round its axis; we should not hesitate a moment in pronouncing such a scheme as a display of consummate folly. But none of these schemes would be half so preposterous as to suppose the vast universe to move round so inconsiderable a globe as the earth, to produce the alternate succession of day and night, when the same object can be effected by the earth's simply revolving around its axis. Such a device, therefore, cannot form any part of the arrangements of Infinite Wisdom. Can we suppose for a moment that what would be considered as the consummation of folly in mankind, is characteristic of the plans and operations of the Divinity, or that the great Source of eternal wisdom is to be leveled below the most foolish of men? Such a thought can never be admitted by any of his intelligent offspring, in relation to Him who is designated "THE ONLY WISE GOD," who "is wonderful in counsel, and excellent in working," and "who hath established the world by his wisdom, and stretched out the heaven by his understanding." If it could be proved that the earth is at rest, and the whole universe in motion around it, I should scarcely admit that the world was framed by that all-wise Being whose character is delineated in the sacred Scriptures, whose wisdom as far transcends that of man as the heavens are high above the earth.

I have been somewhat particular in exhibiting the arguments which prove that the earth is a moving body, because, in some minds, there is a great hesitation in admitting this fact, and in others, a disposition to receive it merely on the testimony of other men, without understanding the foundation on which it rests; and because right views and conceptions of such facts lead to right conceptions of the operations and the attributes of that almighty Being whom we profess to adore. I shall take an opportunity of stating the arguments which prove the annual motion of the globe round the sun, when we come to describe the earth considered as a planet.

## SECTION III.

## REFLECTIONS SUGGESTED BY THE MOTIONS OF THE EARTH AND HEAVENS.

We have now endeavored to prove to the intelligent reader, that the world in which we dwell, with all its continents, islands, oceans, and its numerous population, is continually revolving around its axis to bring about the returns of day and night. It is also flying with a still greater velocity around the sun, to produce the various changes of the seasons. What an august and sublime idea does this suggest for our occasional contemplation! While we are apt to imagine we are sitting in absolute rest in our apartments, we are in reality whirling round toward the east at the rate of hundreds of miles an hour; and are, at the same time, carried through the regions of space with a velocity of sixty-eight thousand miles every hour; so that during every moment, or every pulse that beats within us, we are carried nearly twenty miles from that portion of space we occupied before. When we lie down to sleep in the evening, we are seldom aware that, during our seven hours' repose, we have been carried along through the space of four hundred and seventy thousand miles! When, amidst the gloom of winter, we look forward to the cheering scenes of spring, we must be carried forward more than a hundred millions of miles, before we can enjoy the pleasures of that season; and when spring arrives, we must be carried through the voids of space, hundreds of millions more, before we can enjoy the fruits of harvest. During every breath we draw, and every word we speak, we are carried forward in our course thirty, forty, or fifty miles, unconscious of the rapidity of our flight; but the motion is not the less real, because we do not feel it. What should we think if we beheld one of the largest mountains in Scotland flying through the atmosphere, across the island of Great Britain, with a velocity which would carry it from John-o'-Groat's to the Land's End, a distance of seven hundred miles, in seven minutes? It would, doubtless, excite universal wonder and astonishment. But this is not one-tenth part of the velocity with which the great globe of the earth, and all that it contains, lies through the boundless regions of space. Were we placed on a fixed point, a thousand miles distant from the earth, and beheld this mighty globe, with all its magnificent scenery and population, thus winging its flight around the sun, and carrying the moon along with it in its rapid career, such a spectacle would overwhelm us with astonishment inexpressible, and even with emotions of terror, and would present to view a scene of sublimity and grandeur beyond the reach of our present conceptions. To angels, and other superior intelligences, when winging their flight from heaven to earth, and through distant worlds, such august scenes may be frequently presented.

Although the heavens do not in reality move round the earth, as they appear to do, yet there are thousands of globes in the celestial regions whose real motions are more swift and astonishing than even those to which we have now referred. The planet Venus moves in its orbit with a velocity of eighty thousand miles an hour; Mercury at the rate of one hundred and nine thousand miles an hour; and the planet Jupiter, which is one thousand four hundred times larger than the earth, at the rate of nearly thirty thousand miles an hour, carrying along with it in its course, four globes, each larger than our moon.

Some of the comets have been found to move more than eight hundred thousand miles in the space of an hour; and some of the fixed stars, though apparently at rest, are moving with a velocity of many thousands of miles an hour. In short, we have every reason to believe that there is not a globe in the universe, nor a portion of matter throughout creation, but is in rapid and perpetual motion through the spaces of infinity, supported by the arm of Omnipotence, and fulfilling the designs for which it was created.

If we inquire into the original cause of these motions, we shall find that no other cause can be assigned but the fiat and the power of that omnipotent Being who at first said, "Let the universe appear," and it started into being. As matter did not make itself, so neither can it move itself; its motion must commence, and can only be continued every moment, by the power of that almighty Being who brought it into existence. He alone who existed from eternity, whose power is uncontrollable, and whose wisdom is unsearchable, is the original Source of all motion, as he is the Source of all life and animation. By his omnipotent arm the planets were at first launched into existence, and impelled in their swift career, and the motion at first communicated, is every moment continued by the incessant agency of the same almighty Power. Were that Power to withdraw its energy, or the subordinate means by which it is appointed to be continued, the universe would soon run into confusion, and creation be transformed into a chaos. But God, who "stretched out the heavens, and laid the foundations of the earth," hath appointed them a decree which they cannot pass, and they continue to this day, according to his ordinances, for all are his servants. Psalm cxix. 91.

What a scene of wonders is presented to view when we contemplate the motions incessantly going forward throughout creation!—that thousands of globes, much larger than our world, are winging their flight with unremitting speed, through the regions of immensity, at a rate which overwhelms the human imagination! What an astonishing idea does this convey of the energies of the Eternal Divinity, who at first launched this earth and all the planetary globes from his powerful hand! He only "spoke, and it was done;" and for thousands of years such motions have been continued without intermission! Well may we exclaim, with the inspired writers, "Who can by searching find out God?"—"Who can utter the mighty acts of the Lord? Who can show forth all his praise?"

There are certain practical instructions which may be deduced from this subject. The power of God, as displayed in the motions of the earth and heavens, teaches us that nothing can be too hard for Jehovah, and that all the declarations of his word, however wonderful and inexplicable to mortals, shall, in due time, receive their full accomplishment. We are assured, by the declaration of the sacred oracles, that a period is approaching when all the millions of the human race, whose bodies are now putrefying in the grave, and all the succeeding generations of men until the close of time, shall be reanimated from the tomb, and arrayed in more glorious forms than they now wear. We are also assured that this globe, on which we now reside, is destined to undergo an important and universal change, when its elementary parts "shall melt with fervent heat," and "the earth also, and the works that are therein shall be burned up," as to their present constitution and aspect, and that a new arrange-



ment will take place, in reference to the habitation to be allotted to the righteous. We perceive no symptoms of such changes at present; we have never seen any of the dead rise to life, after their bodies had mingled with the dust, and the ashes of some of them been scattered by the winds over different regions of the sea and land; and therefore doubts are apt to arise in the mind, whether such wonderful transformations are possible to be effected. But all such doubts are at once dispelled, when we consider the perfections of Jehovah as displayed in the structure, and particularly in the movements of the universe, which afford us a sensible demonstration, that nothing, however inexplicable to us, can be beyond the range of Omnipotence. Therefore, we may rest assured that, when the time appointed in the decree of Heaven arrives, that power which carries the earth and all the celestial orbs in their rapid motions through the sky, shall be exerted in re-animating all the generations of mankind, now sleeping in the tomb; in producing a most wonderful change in the aspect of this terraqueous globe; and in causing "new heavens and a new earth" to arise, wherein righteousness shall dwell forever. For that power which carries thousands of vast globes through the regions of immensity,

with velocities of a hundred thousand miles in the short space of an hour, must be more than adequate to accomplish all the glorious scenes and transformations predicted in the records of the Christian revelation. The Christian may therefore rely with unshaken confidence on all the "great and precious promises" contained in the Scriptures of truth, which are given forth by Him whose faithfulness is established in the very heavens, and who "keepeth covenant and mercy with them that love him and keep his commandments to a thousand generations," and therefore cannot fail of ultimately receiving their full accomplishment. Well, therefore, may the believer in Christ exclaim—

"If my immortal Saviour lives,  
Then my immortal life is sure:  
His word a firm foundation gives;  
Here let me build and rest secure.

"Here let my faith unshaken dwell:  
Immovable the promise stands;  
Nor all the powers of earth and hell  
Can e'er dissolve the sacred bands.

"Here, O my soul, thy trust repose!  
If Jesus is for ever mine,  
Not death itself, that last of foes,  
Shall break a union so divine."

## CHAPTER III.

### DESCRIPTION OF THE SUN—OF THE INFERIOR PLANETS—AND OF THE EARTH AND MOON.

WHEN we take a particular survey of the starry heavens, we find that the stars, in general, never shift their positions from each other. They appear to move round us in one compact body, as the figures of the constellations do on a celestial globe, when it is turned round its axis; but the stars belonging to one constellation never move toward those of another, nor change their distances from each other. If we direct our attention to the stars of the Great Bear, for example, (see fig. 1), we shall find that, at all hours of the day and night, and at every season of the year, they present the same definite figure, and the same relative position to each other, without any sensible variation of distance or magnitude; and the same may be observed from one year to another. Hence, they are usually denominated "the fixed stars." But when we observe the heavens with still more accuracy and minuteness, we shall occasionally perceive a few bodies, having the appearance of stars, which, when carefully watched, for a few weeks or months, will be found shifting their positions with respect to the surrounding stars. In most cases, their motion is toward the east, but not unfrequently toward the west, and, at certain times, no motion can be observed for a considerable number of days. The bodies which are thus perceived to change their positions among the stars are called PLANETS; which word signifies "wandering stars."

There are ten orbs of this description which have been traced in the heavens, and whose motions have been accurately ascertained. Only five of these bodies are visible to the naked eye; the other five can be seen only with telescopes. The five planets visible to the unassisted eye were known to the ancients, who gave them the following names, derived from the heathen mytho-

logy; namely, Mercury, Venus, Mars, Jupiter, and Saturn. The other five were discovered by means of the telescope, within the space of the last seventy years. They are named Vesta, Juno, Ceres, Pallas, and Uranus. By a careful investigation of the motions and other phenomena of these bodies, astronomers have ascertained that they all move round the sun as the center of their motions; and, along with the earth, and nineteen smaller globes, form one grand and harmonious system, with which we who live on the terraqueous globe are intimately connected. The central orb which enlightens these moving bodies, and by its influence preserves them in harmony and order, is the same sun that enlightens our day, and diffuses life and animation among all the animal and vegetable productions of our globe. These bodies, although they sometimes appear in different and even opposite regions of the heavens, occupy but a very small space, as to the range of their motions, compared with that which is occupied by the fixed stars. The whole assemblage of these moving orbs, including the earth, is what is generally denominated THE SOLAR SYSTEM, of which we shall now proceed to give a general description, beginning at the center of the system, and proceeding to the different planets as they lie in order.

## SECTION I.

### THE SUN.

THE sun is the grand center and animating principle of the planetary system, around which all the planets revolve, at different distances, and in different periods of time; and by whose attract-

ing influence they are retained in their respective orbits From this source they all derive light and heat, and all the other influences requisite to fit them for being habitable worlds.

Among all the objects of the visible creation, there is none whose beauty is so much admired, and whose benign influence is so generally appreciated, as the sun. Every day this glorious orb visits us with his cheering beams, dispels the shades of night, and diffuses joy and animation among all the tribes of sensitive existence; without whose powerful energy, our world would soon become a dark and shapeless chaos, without life, order or enjoyment. But the splendor of this luminary, and the benefits it confers, are so common and so regularly continued, that we are apt to view them with indifference; and we seldom contemplate, with the eye of an enlightened understanding, the wonderful nature of that globe on which surrounding worlds depend for all the comforts and beneficial agencies they enjoy. To the vulgar eye, the solar orb appears only like a flat luminous circle of a few inches diameter; and there are thousands of mankind who consider it in no other light than as a brilliant lamp, of no great size, hung up in the firmament to give us light by day, and to enable us to prosecute our daily labors. Even minds of a more elevated and reflecting cast have seldom entered into all the sublime ideas connected with the nature and properties of this august luminary; and it is questionable whether the greatest astronomer now existing is capable of forming a conception of the magnitude and sublimity of the solar orb, corresponding to its vast extent and its real grandeur, as the soul, and center, and connecting principle of mighty worlds.

Of the *magnitude* of this stupendous globe arithmetical numbers can scarcely convey to us an adequate idea: but we may, in the first place, state its dimensions in numbers. Its diameter, or a line passing through its center from one side to another, is found to be 880,000 miles. Its circumference, or a line going quite round it, is 2,764,600 miles. Its surface contains 2,432,800,000,000 of square miles; that is, more than twelve thousand times the number of square miles on our globe. Its solid contents comprehend 356,18,739,200,000,000 or three hundred and fifty-six thousand billions of cubical miles; that is, 1,350,000 times the number of solid miles which the terraqueous globe contains; so that were one million three hundred and fifty thousand globes as large as the earth to be compacted into one globe, it would only equal the size of the sun! Some of these dimensions may be somewhat illustrated as follows: Suppose a person to move round the sun's circumference at the rate of forty-five miles every day, it would require more than one hundred and sixty years before the circuit could be completed. Suppose one were to traverse the whole surface of this luminary, so as to pass over every square mile on its surface, at the rate of sixty miles a day, it would require more than a hundred millions of years before such an object could be accomplished. It is stated that the splendid view from Mount Etna comprehends a circle two hundred and forty miles in diameter, containing 45,240 square miles. Now this is only the fifty-three millionth part of the surface of the sun; so that more than fifty-three millions of landscapes, such as beheld from the top of Etna, must pass before us ere we could contemplate a surface as extensive as that of the sun. Were we to suppose every such landscape to occupy two hours in the contemplation, it would require twelve thousand

two hundred and seventy-five years—without the least intermission—or more than double the time which has elapsed since the Mosaic creation, before the whole surface of this immense globe could be, in this rapid manner, surveyed. The magnitude of this luminary may also be illustrated from the following comparison: The earth contains about two hundred and sixty-four thousand millions of cubical miles; the planet Jupiter is fourteen hundred times larger than the earth; Saturn is about a thousand times; and Uranus about eighty times larger than the earth: yet the sun is found to be more than five hundred times larger than those planets, and all the other planets, moons, and comets of the solar system taken together.

If it be asked why the sun appears so small to our eyes, if it is indeed so immense a globe, it is easily answered, that this is owing to its immense distance from our world. This distance is no less than ninety-five millions of miles,—a distance of which the mind can form only a very inadequate conception. It may be somewhat illustrated, however, as follows: A cannon ball, at its utmost speed, when it leaves the mouth of a cannon, is calculated to fly at the rate of about five hundred miles an hour; but it would require such a moving body—though flying continually with this velocity—twenty-one years and two hundred and forty-five days before it could reach the sun. This may be further illustrated by motions with which we are more familiar. Suppose a steam-carriage to set out from the earth in the direction of the sun, and to move, without intermission, at the rate of four hundred and eighty miles every day, it would require five hundred and forty-seven years before it could traverse the space which intervenes between us and that distant luminary. How wonderful, then, that the sun, at such a distance, should exert his attractive power upon the earth—fructify the soil—raise tides in the ocean—and diffuse light, and heat, and color, and animation, over all its regions! And not only so, but even on the remotest planet of the system, at the distance of eighteen hundred millions of miles, similar influences are produced by the agency of this august luminary!

Are we startled at the vast distance and dimensions of the solar orb which we have now stated? and are we apt to doubt whether the representations we have given be accordant with fact? We ought to consider that He who made the sun, and adorned him with the splendor he exhibits, is "THE LORD GOD OMNIPOTENT," the extent of whose power and wisdom none can comprehend; and that the sun required to be of such a magnitude to give stability to the system of which he is the center; and, according to the laws he hath impressed upon the material world, to retain surrounding worlds in the paths prescribed them, and to dispense to them all those influences which they require. If we are astonished at the magnitude of the sun, how must our admiration be raised when we consider that this globe is only one out of millions of similar globes which exist in the universe! For every star that adorns our firmament is, on good grounds, concluded to be a sun, no less spacious and luminous than that which enlightens our day; and has, doubtless, a retinue of planetary globes revolving around it, as the center of light and influence.

*Nature and physical constitution of the Sun.*—Of the real nature of this luminary we have hitherto acquired but very imperfect conceptions. But since the invention of the telescope, our knowledge of its constitution has been somewhat en-

arged. We no longer view the sun as a ball of liquid fire, as had sometimes been supposed, but as a solid body, composed of different materials, in which wonderful processes are going forward on an extensive scale, for preparing and perpetuating that light and heat which are destined to cheer and illuminate surrounding worlds. When the sun is viewed by means of a telescope, spots of various kinds are perceived upon its surface. These spots appear first on its eastern margin, when they appear narrow and somewhat obscure; they move gradually onward to the center of the disc, when they appear largest and most distinct; afterward they proceed toward the western limb, where they again appear narrow and obscure; and after a period of about thirteen days, from their first appearance on the eastern edge, they disappear from the western limb; and, in many cases, they again appear on the eastern limb, after the same period of thirteen days. But they are frequently somewhat changed in their aspect before they reappear; and, in numerous instances, after disappearing from the sun's western boundary, they are never again visible in the same shape; but other spots, at uncertain intervals, are seen diversifying the solar disc; though not unfrequently scarcely a single spot is to be seen over the whole surface of the sun. The spots appearing narrower and less distinct on the eastern and western limbs, is owing to our viewing obliquely these parts of the sun's surface. The conclusions to be deduced from these circumstances are, 1st, that the sun is a globe, and not a flat surface, as it appears to the naked eye, otherwise the spots would appear equally large and distinct on every part of its surface. 2d. That this luminary moves round its axis in the same direction as the rotation of the planets; for its spots do not shift their places on its disc, but are carried along with the whole body of the sun. The time of the apparent revolution of these spots is 27 days, 8 hours; but the real period of the sun's rotation is 25 days, 9 hours, 56 minutes; and therefore, the places about the sun's equator move at the rate of four thousand five hundred and thirty-two miles an hour.\*

The solar spots are of all sizes, and of different shapes: their size is from  $\frac{1}{60}$ th to  $\frac{1}{30}$ th of the sun's diameter. The smallest of those spots which can be distinctly seen, are nearly a thousand miles in diameter. Spots, the one-fiftieth part of the diameter of the sun—which we have frequently seen—are 17,600 miles in diameter, or more than double the diameter of the earth; and if the spot be considered only as a plane, and somewhat circular, it will contain more than two hundred and forty-three thousand square miles, which is considerably more than the area of the whole terrestrial globe; and yet sometimes a spot of this vast size will disappear in a few weeks, and not unfrequently in a few days. Sometimes not a single spot is to be seen on the solar disc for weeks and even for months together; at other times, we have seen above one hundred spots of all sizes dispersed over the face of the sun at one time. In such cases, there are generally five or six large spots, such as that alluded to above, accompanied with ten, fifteen, or twenty smaller spots; but, after disappearing at the sun's western limb, it is seldom that they come round again in the same order as before. Some appear to have been alto-

gether dissipated, and others to have changed their shape and relation to surrounding spots, in which they formerly appeared. We have seen spots of nearly 2000 miles in diameter vanish in the course of twenty-two hours: and, on the other hand, on a late occasion, we beheld two spots, each of them larger than the earth, and containing at least three hundred millions of square miles, which were formed near the center of the solar disc, where no trace of them was seen forty hours before; which circumstances show the amazing rapidity with which these mighty masses are formed, and again rendered invisible to the sight. The portions of the sun's surface where the spots most frequently appear, are those which lie adjacent to its equatorial regions; no spots being ever seen near its northern or southern poles. In some years, these spots have been very numerous, and seldom a week has passed without a few of them having been seen, while in other years, comparatively few have been visible.

These spots, as to their general appearance, resemble a dark nucleus, surrounded with a penumbra, or belt of a lighter shade. This penumbra is generally of a shape nearly corresponding to that of the dark nucleus, or central spot. This fainter belt is plainly perceptible in the larger spots, and when very high powers are applied to the telescope, the umbrae are also visible in the smaller spots. The following representations will convey a general idea of the phenomena of the solar spots. Fig. 6 represents the more common appearance of these spots—a dark central part surrounded by a fainter shade. Figs. 7, 8, 9, represent the appearances of certain spots which exhibit a bright spot, or figure, in the midst of the dark nucleus. Fig. 10 shows a spot, in which various dark spots are surrounded by one common penumbra; figs. 11, 12, spots of different shapes; figs. 13, 14, large spots accompanied or surrounded with dark spots of a much smaller size. This is a very common phenomenon: it is seldom that any large spots are seen without being accompanied with a variety of small spots of different sizes, frequently assuming the appearance of a tail to the large spot. Fig. 15, represents the appearance and progress of a single spot, from the time it appears on the sun's eastern limb until it arrive at the center of the disc. As the sun moves round an axis which is not perpendicular to the ecliptic, but inclined seven and a half degrees from the perpendicular, so the spots move in a line deviating from the ecliptic, and perpendicular to the sun's axis. Thus, in fig. 16, A B represents the ecliptic; D C its axis perpendicular to it; G H the axis of the sun, around which it performs its rotation, deviating seven and a half degrees from D C, the axis of the ecliptic. The spots therefore move in a line E F or K L, which is at right angles with the axis of the sun.

Beside the dark spots whose phenomena we have now described, there are spots which have a bright and mottled appearance, and which it is difficult, in most cases, to distinguish from the general body of the sun. They are chiefly to be seen when they first appear on the eastern margin of the sun, and when they approach near the western limb; but they are seldom or never seen near the middle of the disc. They are most generally seen in connection with clusters of the dark spots, and when they are first seen near the eastern limb, they frequently indicate that dark spots are about to make their appearance. They appear like luminous ridges, and plainly indicate that the sun is not a smooth surface, but is diversified with elevations and depressions, or, in other

\* This is found by dividing the circumference of the sun = 2,764,600 miles, by the number of hours in which the rotation is performed, namely 610 hours, and the quotient is the rate of motion per hour.

words, with mountains and vales of a stupendous size, otherwise we could not perceive them at the remote distance at which we are placed. But what these bright ridges, or corrugations, are—whether immense luminous clouds, or solid bodies—or what purpose they serve in the operations which are going forward in this luminary, we are unable to determine.

The following is a summary of the phenomena of the solar spots. 1. Every spot which has a dark nucleus has also an umbra surrounding it. 2. The boundary between the nucleus and umbra is well-defined. 3. The increase of a spot is

gradual, the breadth of the nucleus and umbra dilating at the same time; and its decrease is gradual in the same manner. 4. The nucleus, when on the decrease, in many instances, changes its figure by the umbra encroaching upon it; and thus it sometimes happens that the nucleus is divided into two or more nuclei. 5. The exterior boundary of the umbra never consists of sharp angles, but is always curvilinear. 6. The nucleus vanishes sooner than the umbra.

The conclusions which have been drawn from the phenomena now described, in reference to the constitution of the sun, are as follows: That the

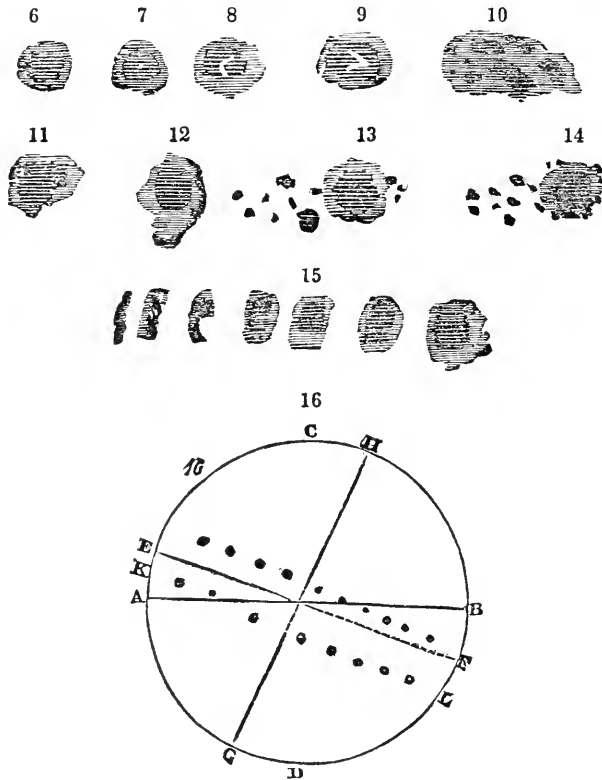

central part of the spots is beneath the level of the sun's surface, or, in other words, that the spots are excavations in the body of this luminary, and that the umbra, or shade, which surrounds it, is the shelving sides of this excavation in the luminous matter. According to this view, the nucleus is nothing else than the dark and solid body of the sun appearing through the openings of a luminous atmosphere which surrounds this mighty globe. According to Sir W. Herschel's estimate, this atmosphere is not less than 1840 miles, and not more than 2760 miles in depth. This he regards as the outermost coating of the sun, or his visible surface; and under this superior stratum, he conceived there is another, more dense and highly reflective, which throws back the light of the upper regions, and that this lower atmosphere constitutes the umbra of the spots, and that the dark central parts of the spots, or, the nuclei, are part of the solid matter of which the sun's body is composed. In accordance with such views, the internal part of the sun may

be considered as an immense solid ball, not altogether unlike the earth and the other planets; and there is no great improbability in supposing that it is fitted for being the habitation of sensitive and intelligent beings, with constitutions adapted to the situation; and that it may constitute the most glorious habitation connected with the solar system. But whatever may be the real nature and constitution of this luminary, it is evident, from the rapid and extensive changes which are frequently happening both among the bright and dark spots, that there are forces of prodigious power in continual operation, producing the most astonishing effects, in a short space of time, sometimes in a few hours or minutes, on the surface or in the luminous atmosphere of this great central body. And such changes are, doubtless, necessary for preserving the present constitution of the sun—for enabling him to diffuse light and heat—and to act as the soul of surrounding worlds.

This magnificent luminary is the grand source

of light, and heat, and color to this earth, and to all the planetary globes, with their rings and satellites, which belong to our system. By its energy and influence, it cheers, adorns, and animates a retinue of mighty worlds; directing their motions, and preserving them all in the paths prescribed them, so that none shall wander from their course, or interfere with others. It is the central bond which unites the moon to the earth; the satellites of Jupiter, Saturn, and Uranus, to their respective primaries, and all the other planets in one grand and harmonious system. On our globe, the benign effects of the sun are numerous and powerful. He is not only the source of illumination, but of all that beautiful diversity of coloring which adorns every terrestrial landscape. Both the earth and sea—the lowest depths of the ocean, and the darkest cavern—feel the effects of his powerful agency. All animated beings rejoice in his presence: when his rays dispel the shades of night, millions of the insect tribes awake and sport in his beams, the birds salute him with their melodious concerts, everything that breathes feels the effect of his influence; man watches for the morning and rejoices at his approach; for “truly the light is sweet, and a pleasant thing it is for the eyes to behold the sun.” The vegetable tribes likewise feel his energy: he gives circulation to the sap in plants and trees; he causes the blossoms and leaves to shoot; the hills and vales to be covered with verdure, and the fruits of the earth to ripen to a golden harvest, for supplying the wants of man and beast. Without the influence of this luminary, darkness and all its gloomy accompaniments would forever involve this lower creation; all the beauties which now adorn the face of nature would be swept away, the birds would cease their warblings, the flowers would no longer be decked with the gayest colors, nor shed their rich perfumes. Life, activity, and animation would soon cease; and the earth, ere long, would be transformed into a hideous chaos.

Can we reflect on the grandeur and magnitude of this luminary, and the manifold beneficial effects which it produces on our world, without raising our thoughts to Him who at first launched this vast globe from his almighty arm, and still sustains it in all its energies! In all our surveys of the system of nature, it becomes us to raise our views from the effect to the cause, from the creature to the great Creator, and to give to Him “the glory due to his name.” This is not only a duty inculcated in Scripture, but is in full accordance with the dictates of true philosophy; which declare, that every phenomenon, and every effect in the universe should be traced up to a cause adequate for its production. And what cause could produce such a stupendous luminary, but that Being who existed from eternity, whose power is uncontrollable and illimitable, and whose “kingdom ruleth over all?” In the formation of this spacious globe we behold a display of Omnipotence which overwhelms our conceptions, and which shows us that nothing, however amazing and incomprehensible, can be beyond the limits of God’s power to accomplish. In the numerous beneficial agencies produced by the sun, we have a display of his beneficence, an evidence that the happiness of his creatures is one of the main objects of his creating power, and that “his tender mercies are over all his works.” “The day is thine; the night also is thine; thou hast prepared the light and the sun.” He hath placed our world at such a distance from this luminary, as neither to daz-

zle us with excessive brilliancy, nor scorch us with excessive heat, nor freeze us with insufferable cold; but to produce an illumination and a temperature suited to the inhabitants of every clime. The man who can contemplate this glorious object, and feel all the beneficial effects of its influence, without the least emotion of gratitude, reverence, and adoration, scarcely deserves to enjoy the beneficence of his Creator. Let us, then, “give thanks unto the Lord—to him that made great lights—the sun to rule the day: for his mercy endureth forever.” And as the sun enlightens, cheers, and fructifies our globe, and distributes benefits wherever he shines; so let us likewise, according to our power and opportunities, exert all our energies in imparting blessings to our brethren of mankind. As he daily sheds his benign influence around the world; as he rises for the benefit of the ungrateful and the unjust, as well as for the good and the righteous, so let our beneficence be displayed toward men of all characters and nations, that we may prove ourselves to be “the children of the Most High,” who, without distinction of persons, distributes blessings without number, among all the ranks of sensitive and intelligent existence.

Notwithstanding the numerous benefits which the sun dispenses to all the inhabitants of our globe, it is a melancholy truth that the greater part of its population is still involved in intellectual darkness and moral debasement, “being alienated from the life of God through the ignorance that is in them.” In this respect, it may still be said, as in ancient times, that darkness covers the earth, and gross darkness the majority of the people who inhabit it. While the sun diffuses its splendor around them, their minds are shrouded in a midnight gloom, into which “the light of the knowledge of the glory of God,” as it shines “in the face of Jesus Christ,” has never penetrated. Before all the effects of light—material and mental—can be fully felt, the Sun of righteousness must arise on the nations “with healing in his beams,” to diffuse knowledge, joy, and salvation. His influences are as necessary to our true happiness as those of the material sun to our external comfort and existence. His Spirit irradiates the darkest understandings, purifies the most debased affections, and diffuses gladness and consolation wherever the light of Divine truth shines into the heart. And as the rays of this spiritual Sun are diffused by the truths of revelation, it is our duty to disseminate these truths as extensively as possible among all the kindreds, and families, and tribes, that dwell upon the face of all the earth. Wherever the natural sun shines, the light of Divine truth should be made to shed its influence and its luster, until light shall spring up to those who sit in darkness and the shadow of death; until “the glory of the Lord shall cover the earth—and all flesh see the salvation of God.”

## SECTION II.

### THE PLANET MERCURY.

HAVING given a general description of the sun—which is the center of the planetary orbs, around which they all perform their revolutions, at different distances and in different periods of time, we shall now proceed to give a brief description of what is most interesting in the phenomena of the different planets, beginning with that which is nearest the center, and proceeding, in order, to

those which are most distant. The order in which the orbits of the planets lie from the sun is represented in the following small diagram. The proportional distances of the planets from the center cannot be distinctly represented, unless upon a diagram of very large extent. In this small figure, the middle point represents the position of the sun. The inner circle next the point which rep-

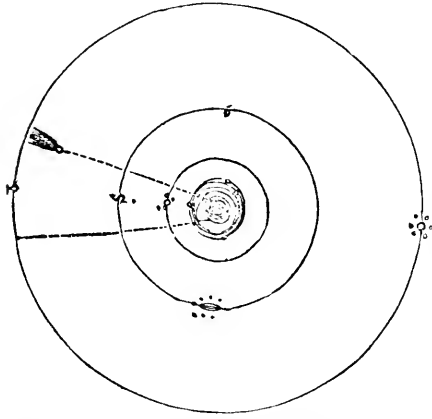

resents the sun, is the orbit of Mercury, the nearest planet to the sun; the second circle represents the orbit of Venus; the third that of the Earth; the fourth that of Mars; the next circles, which cross each other, represent the orbits of the lately discovered planets: Vesta, Juno, Ceres, and Pallas. Beyond these, the next circle represents the orbit of Jupiter with his satellites, and next to that the orbit of Saturn. The outermost circle is that of Uranus, sometimes distinguished by the names of Herschel, and the Georgium Sidus.

These orbits appear very small, as delineated in this diagram; but they are in reality so immensely large, that the mind can scarcely form any adequate conception of them. The orbit of Mercury, which is the smallest, is more than two hundred and thirty-two millions of miles in circumference. Were a steam carriage to move round it at the rate of twenty miles an hour, it would require more than one thousand three hundred and twenty-four years before it could complete the circuit; yet the planet itself moves around it in the short space of eighty-eight days. The orbit of Uranus, the most distant planet of the system, is eleven thousand three hundred millions of miles in circumference, and three thousand six hundred millions in diameter. To move round this circumference, at the rate of thirty miles an hour, would require above forty-two thousand nine hundred years, or more than seven times the period which has elapsed since the creation of Adam; while the planet itself moves round it in eighty-four years. So that all the arrangements of the Divine Being are conducted on a scale of magnificence, astonishing to mortals, and corresponding to the infinite majesty and grandeur of Him "who stretched out the heavens by his understanding."

The narrow curve, on the left hand of the figure, crossing the orbits of the planets, represents the portion of the orbit of a comet. The comet moves in all directions through the solar system, and their orbits consist of long narrow ellipses, or ovals, some of which extend far beyond the orbits of the most distant planets, and they sometimes remain for a long series of years.

These bodies are distinguished by their dim, dusky, and ruddy light, and the long tails, or trains of light with which they frequently make their appearance. Sometimes they are visible to the naked eye, and make a pretty splendid appearance; but numerous bodies of this description pass near the center of our system, which are only visible by means of telescopes, and numbers, doubtless, which are never distinguished even by astronomers, except when by chance they happen to direct their telescopes to those portions of the heavens in which they are moving. From December, 1843, to September, 1844, no less than three comets were discovered, but not one of them was visible to the unassisted eye.

Having made these preliminary remarks respecting the general arrangement of the planets and comets, we proceed to a brief description of—

**The planet Mercury.** This planet, as already noticed, is the nearest to the sun; at least, no planets, nearer this luminary have yet been discovered, though it is not improbable that one or two may exist within the orbit of Mercury. Its name signifies "the swift messenger," and, in point of fact, it is the swiftest moving planet in the solar system, its rate of motion being, at an average, one hundred and nine thousand eight hundred miles an hour, or one thousand eight hundred and thirty miles in a minute; but its rate of motion is somewhat different in different parts of its course, as it moves in an elliptical orbit. Its distance from the sun is about thirty-seven millions of miles, and it performs its revolution around that luminary in eighty-seven days, twenty-three hours, and twenty-five minutes. As to *magnitude*, this planet ranks among the smaller bodies of the system. Its diameter is three thousand two hundred miles, its circumference ten thousand and fifty-three miles, and its surface contains above thirty-two millions of square miles, which is considerably less than the habitable parts of our globe. Were we to compare its size with that of the sun we should find that it would require nearly twenty-two millions of globes of the size of Mercury to form a globe equal to that of the sun.\*

This planet always appears to move in the neighborhood of the sun. It never appears above twenty-nine degrees distant from the sun, and frequently at the period of its greatest elongations it is not above sixteen or seventeen degrees from that luminary. On this account, it is difficult to be distinguished by the naked eye, unless near the periods of its greatest elongations. The time between its greatest elongations from the sun, varies from one hundred and six to one hundred and thirty days. When it is at its greatest elongation east of the sun, it is seen in the evenings, at a low elevation, not far from the point where the sun sets. When it is west of the sun, it is seen in the morning not far from the point of sunrise. The most favorable seasons for observing it are the spring and autumn, as it is in a higher declination at those seasons than in winter, and the twilight is not so strong nor so long continued as in summer.

\* This is estimated in the following manner—*For comparative bulks of spheres are to each other as the cubes of their diameters; therefore, divide the cubes of the diameters by each other, and the quotient shows the number of times the one is contained in the other.* In the present instance, multiply the sun's diameter, 880,000 miles, twice into itself, and divide the product by the cube of the diameter of Mercury, 3200 miles, and the quotient will give the number of times that the sun is larger than this planet. Thus the cube of 880,000 is 681,472,000,000,000,000, which divided by 32,768,000,000 the cube of Mercury's diameter = 21 millions and five-sixths, nearly.

mer. When viewed by the naked eye, it appears to emit a very white light; and those who would wish to get a view of this planet, when it may be seen, should inspect an almanac, or ephemeris, where the times of its elongations are distinctly stated.\* When viewed with a telescope it appears, in the course of its revolutions round the sun, to pass through all the phases of the moon, sometimes appearing as a half-moon, sometimes as a crescent, and at other times with a gibbous phase. When it appears of a half-moon or crescent phase, its enlightened side, like that of the moon, is always turned toward the sun, which proves that it is in itself a dark body, and derives all its light from that luminary. On account of its nearness to the sun, few discoveries have been made on its surface by the telescope. It has been observed, however, that when it appears as a crescent, one of its horns is truncated, or cut off at the point, by which the period of its revolutions round its axis has been determined, which is supposed to be accomplished in twenty-four hours and five minutes. This truncature is doubtless the effect of elevations and depressions on its surface; and hence, some astronomers have concluded that mountains of considerable elevation exist on Mercury, one of which is calculated to be eight English miles in perpendicular altitude. It is supposed, likewise, that it is enveloped with an extremely dense atmosphere.

In consequence of its nearness to the sun—being nearly three times nearer than the earth—the quantity of light is nearly seven times greater than what we receive; and the sun will appear to a spectator in that planet about seven times larger than to us—which circumstances will cause a more brilliant luster to appear on all the objects on the surface of this planet than appears on the scenery of our globe. Such eyes as ours would be unable to sustain so dazzling a brightness, unless their pupils were contracted to the diameter of one-fiftieth of an inch. That the quantity of heat is in the same proportion, or seven times greater than on the earth, is an opinion by no means probable. It is more probable, from many circumstances connected with our own globe, and from a variety of experiments which have been made on the subject of heat, that the sun's rays may be modified in their action by the nature of the atmosphere, and the constituent elements of which the planet is composed. It is probable that sensible heat depends chiefly on the distribution of the substance of caloric, or the principle of heat, on the surfaces and throughout the atmospheres of the planets, in different quantities, according to the different situations they occupy in the solar system; so that it is possible there may be no more sensible heat felt on the surface of Mercury than on the surface of the earth, or even of Saturn, or Uranus.

Mercury revolves in an elliptical orbit, which is more eccentric than the orbits of the other planets except Juno and Pallas. This is the reason why, at some of its greatest elongations, it is only sixteen degrees from the sun; while at others,

it is nearly twenty-nine degrees distant. Its eccentricity, or the distance of the sun from the center of its orbit, is above seven millions of miles; which is about the one-tenth part of the diameter of its orbit; and this orbit is inclined to the ecliptic, or the plane of the earth's orbit, in an angle of seven degrees, so that it is sometimes this number of degrees above the level of the ecliptic, and at other times as much below it. The density of this planet is greater than that of any other planet of the system. It has been estimated to be nearly twice the density of the earth, that is about nine times the density of water, or nearly equal to that of lead. Such conclusions are deduced from the laws of gravitation, by which all the planets are directed in their motions.

*Transits of Mercury.*—At certain periods, this planet is observed to pass across the sun's disc, like a small dark spot. This can happen only at the time of its inferior conjunction with the sun—when it is nearest to the earth—when its enlightened side is turned toward the sun, and its dark hemisphere is turned directly toward the earth; and when the earth, Mercury, and the sun are nearly in one straight line. This passage of Mercury across the solar disc is called its transit, and is considered by astronomers as an interesting phenomenon. If the orbit of this planet were in the same plane with that of the earth, it would transit the sun's disc at every inferior conjunction, or three or four times every year. But as its orbit is inclined to the ecliptic, a transit can happen only when it comes to the inferior conjunction, at the time when it is at or near its nodes, or the points where it crosses the ecliptic, and when the earth is in the same longitude, and this occurs only at intervals of several years. The last visible transit previous to 1845, happened in 1832; another happened in November, 1835, but was invisible in Britain, as the sun was set before its commencement. A visible transit likewise occurred on May 8th, 1845, which began at 19 minutes past 4, p. m., Greenwich time, and the planet arrived near the center of the disc at 35 minutes past 7, p. m.; but before the planet's egress from the sun's western limb, the sun set to the inhabitants of this country. The next visible transits of Mercury will happen at the following periods: 1848, November 9th; 1861, November 12th; 1868, November 5th; 1878, May 6th. The other transits, during the present century, in 1881, 1891, and 1894, will be invisible in Britain and other European countries, but will be seen in several parts of North and South America, and the islands of the Pacific Ocean.

This planet, notwithstanding its comparative smallness, forms a portion of the Divine empire, and is capable of containing a population larger than even that of our globe. Though diminutive in its appearance, and seldom seen by the inhabitants of the earth, we can scarcely doubt that there are to be found on this planet millions of sentient and intelligent beings—perhaps far superior in dignity to man—with constitutions fitted for that sphere in which Providence has placed them, and with mental powers which qualify them to know, to love, and to adore their great Creator. For it may be considered as an axiom, that the material universe was created, and is still preserved in existence, chiefly for the sake of sensitive and intellectual natures, to afford them the means of happiness, and to give them a sensible display of the character and attributes of the Eternal Divinity.

\* The *Christian Almanac*, published by the "Religious Tract Society," will afford sufficient information on such points, and on various other topics connected with astronomy, and the motions and aspects of the heavenly orbs, especially under the head *Phenomena*. This almanac is published at the low price of sixpence, contains about 84 closely printed pages, and a vast quantity of useful information on science, religion, philanthropy, domestic economy, acts of Parliament, and a variety of other interesting topics.

## SECTION III.

## ON THE PLANET VENUS.

NEXT to Mercury, in the order of the system, is the planet Venus. To the naked eye it appears the most beautiful and splendid star in the heavens, and has been distinguished both in ancient and modern times as the morning and evening star, because in one part of its course, it makes its appearance, in the west, in the evening, before any other star is visible; and, in another part of its course, it appears in the east in the morning, ushering in the dawn, and giving notice of the approach of the rising sun. Its distance from the sun is reckoned at sixty-eight millions of miles, being thirty-one millions of miles from the orbit of Mercury, and about twenty-seven millions of miles from the earth at its nearest approach to it. At this distance it is nearer the earth than any other celestial body can approach, the moon only excepted. In respect of *magnitude*, it is found to be 7500 miles in diameter, or very nearly the size of our globe. Its surface contains one hundred and ninety-one millions of square miles, and the quantity of light it receives from the sun is nearly double of that which falls upon the earth, on account of its greater nearness to the sun, so that that luminary will appear from its surface twice as large as it does to us. From a variety of observations which have been made on this planet, it appears that it has a rotation on its axis, which is accomplished in the period of 23 hours, 21 minutes; and as the period of the earth's rotation is 23 hours, 56 minutes, its day is, of course, 35 minutes shorter than ours.

*Discoveries made on Venus by the telescope.*—The first time the telescope was directed to this planet was in the year 1610, by the celebrated Galileo, who had just a little before constructed one of the first telescopes. The chief discovery he then made was, that this planet, in the course of its revolution round the sun, passed through all the phases of the moon, sometimes appearing as a crescent, or like the moon when three or four days old, sometimes like a half-moon, and at other times with a gibbous phase, or like the moon three or four days before the full. That the planet presents such phases to our eye is a plain proof that it does not move round the earth as its center of motion, as the ancients supposed, but round the sun, in an orbit which lies within the orbit of the earth. For if it moved in an orbit exterior to that of the earth, it could never present to us either a half-moon or a crescent phase. At the period to which we allude, the greater part of the learned had adopted the vulgar opinion which so long prevailed, that the earth is at rest in the center of the universe, and that all the planets revolve around it. It was objected to the Copernican system, which supposes the earth to be one of the planets—and which had been recently broached—that if this were the case, the planets Mercury and Venus would appear with all the phases of the moon. This was fully admitted; but it could never be exhibited to the organs of vision before the telescope was invented. When Galileo had published this and several other discoveries, the senators of Venice, who were most of them eminent for their love of learning, invited this astronomer to come, and in their presence make a trial of his new instrument. He complied with their request; and, on a fine, clear, and serene evening, mounted his telescope on the tower of St. Mark, and showed them several of

the discoveries he had made, and particularly the appearance of Venus, which was then near the point of its greatest elongation from the sun. One senator after another beheld the planet through the telescope, and all were surprised that more than half of its hemisphere was obscured; that it did not appear round, as most of the other heavenly orbs, but inclining to a crescent, with points, or horns, at its opposite sides. Upon this Galileo proceeded to show how this phenomenon furnished a demonstrative proof of the Copernican system of the universe. That night was fatal to the ancient systems maintained in the schools; and from that period, the true system of the world began to be recognized by all intelligent and unprejudiced minds, and, in the midst of every opposition, to be extensively propagated through the world.

After the telescope was improved, and its length and magnifying powers increased, more particular observations began to be made on the surface of Venus. Cassini, an Italian astronomer, with instruments of a large size, on October 14th, 1666, at 5h. 45m., p. m., saw a small bright spot, near the section between the dark and bright side of the planet; at the same time he noticed two dark oblong spots nearer the other side of the disc, as represented in fig. 18. On the 29th of April, 1667, in the morning, a little before sunrise, he perceived, on the disc of the planet, then half enlightened, a bright spot near the section and toward the lower horn; and nearer to the northern horn he saw a darkish oblong spot, as represented in fig. 19; and after sunrise, he perceived that the bright spot was advanced considerably from the southern horn; and from this and several subsequent observations, he had a plain proof of the rotation of the planet, which he afterward determined to be in the space of somewhat more than twenty-three hours. For many years after this period, we have few recorded observations of these spots; and, indeed, they are very difficult to be perceived, on account of the extreme brilliancy which this planet exhibits, and the undulations of the atmosphere, when viewed at a low altitude in the evening. The best time for viewing the surface of this planet is in the day-time, when it is near the meridian, by means of large equatorial telescopes.

M. Schroeter, a late celebrated German astronomer, made a variety of observations on this planet, from which he has deduced several important conclusions. He discovered the twilight of Venus, or the stretching of a faint light beyond the semicircle which ought to be alone directly enlightened, as shown at fig. 20, where the cusps or horns seem to stretch into the dark hemisphere. He deduced from this, and other observations, that Venus has an atmosphere of considerable extent, the densest part of which is above three miles high. A similar conclusion was deduced by a variety of observers in different places, when viewing the transit of this planet in 1761. At the time when the planet entered on the sun's disc, and when it was about to emerge from the eastern limb, a faint penumbra or dusky shade was seen surrounding the planet, which indicated an atmosphere of considerable height. M. Schroeter likewise detected several mountain ridges, and elevations of great magnitude on the surface of Venus. Such elevations are ascertained from the length of their shadows. He estimated the perpendicular height of one of these mountains to be ten and a half English miles, and of another no less than nineteen miles. Although these elevations so far surpass the height of the highest mountains on our globe,



yet such estimates are not to be considered on this account as improbable. For, in nature, there is an infinite variety, and every planet differs from another in its arrangements. Such lofty elevations will add to the sublimity of nature on the surface of this planet, and will afford, from their summits,

prospects far more extensive and sublime than we can at present conceive.

*Apparent motions of Venus.*—Were the planets viewed from the sun, the center of the system, their motions would appear nearly uniform, and in one direction, from west to east. But when viewed

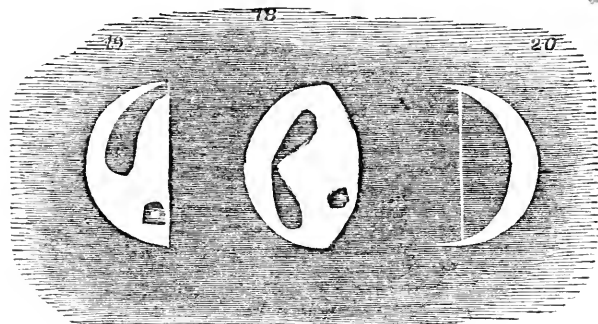

from the earth, or any other planet, their motions appear very irregular, and in different directions, and sometimes they appear to make a pause in their course. Hence the apparent motions of the planets, as viewed from the earth, are said to be either direct, retrograde, or stationary. This may be illustrated in the apparent motions of Venus, and what is here stated of this planet will equally apply to the motion of Mercury. Thus, in fig. 21, let S represent the sun, E the earth, and *a, b, c, d, e, f, g, h*, the planet Venus in different parts of its orbit, as seen from the earth at E. When it is at *a*, it is said to be in its inferior conjunction with the sun, because it is then nearly in a line with the sun; and were it visible, it would be seen nearly in the same part of the heavens as the sun. But at this time its dark hemisphere is turned toward the earth, and therefore is invisible unless it

*c* the planet is said to be at its greatest western elongation from the sun, when it appears in its greatest brightness as a morning star. In passing from *c* to *d*, and from *d* to *e*, its motion is direct, or from west to east. At *e* is the point of its superior conjunction, when it is again nearly in a line with the sun, and when its full enlightened hemisphere is turned toward the earth. But at this point it is the whole diameter of its orbit, or one hundred and thirty-six millions of miles farther from the earth than when it was at *a*, and therefore appears smaller near this position than when only the one-fourth of its enlightened side is seen. From *e* to *f*, and from *f* to *g*, the motion is still direct; from *g* to *h*, it is again stationary, and from *h* to *a* retrograde.

In regard to the *phases* of Venus we may add the following remarks. When the planet is at *e*, at its superior conjunction, if it could then be seen,\* it would present a full enlightened hemisphere. As it moves from *e* to *f*, it gradually comes into view as an evening star, and at first appears very low near the point of the horizon where the sun sets. Its motion appears slow on account of its distance from the earth, and it is sometimes two or three months, after passing the point of its conjunction, before it becomes distinctly visible to the naked eye. When it comes to the point *f* it exhibits a gibbous phase, as seen by the telescope. As it moves onward toward *g*, its apparent size increases, and its gibbous phase gradually declines to that of a half-moon. At *g* it appears like a half-moon inclining to a crescent. About this point of its orbit is the period of its greatest brilliancy, and in certain years, when in this position, it may be seen in the day-time by the naked eye. At the point *h*, it appears of a cres-

Fig. 21.

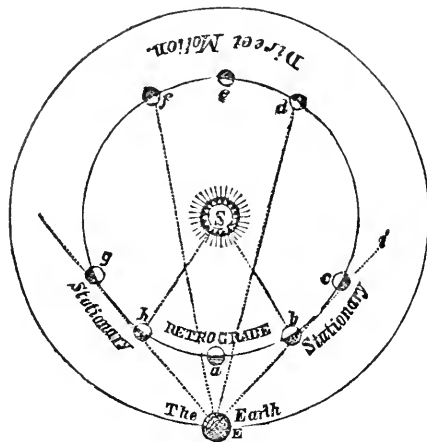

should happen, as it sometimes does, to pass across the disc of the sun. In moving from *a* to *b*, its motion is retrograde, or toward the west. In moving from *b* to *c*, it appears stationary, because the tangent line, or visual ray *b i*, will appear for some time to coincide with the orbit of the planet. At

\* It has been frequently asserted by astronomical writers that this planet cannot be seen at its superior conjunction. The author of this volume, however, in the course of his observations on the heavenly bodies in the day-time, had an opportunity on the 2d of October, 1843, of seeing this planet within a few minutes of the time of its superior conjunction, when it was only 58 minutes, or less than 1 degree from the sun's margin. It was viewed with a three-foot-and-a-half achromatic telescope, magnifying 95 times, and appeared round and perfectly distinct, though partly immersed in the solar rays. This circumstance proves that the surface of Venus reflects the solar rays with peculiar brilliancy, more than that of any other planet. For a more particular account of this observation, see "Edinburgh New Philosophical Journal" for January, 1844.

cent form, and while moving from *h* to *a*, the point of its inferior conjunction, its crescent becomes more slender, but at the same time more expansive, until it appears like the crescent of the moon when she is less than two days old. At *a* the dark side of the planet is turned toward the earth, and consequently invisible. The period employed in passing through these changes, from *e* to *a*, is about nine months and a half. In passing through the other semicircle from *a* to *b*, *c*, *d*, *e*, it becomes a morning star, and a few days after the conjunction, is seen in the east preceding the rising sun. In proceeding from *a* to *b* and *c*, its apparent motion is rapid, and it presents a crescent phase; at *c* it appears like a half-moon, and in the remaining part of its course to *e* its phase is gibbous, until it arrives at the superior conjunction, when it again presents a full enlightened hemisphere. The time employed in moving from the inferior to the superior conjunction is, as formerly, about nine months and a half.

The following figures represent the phases of

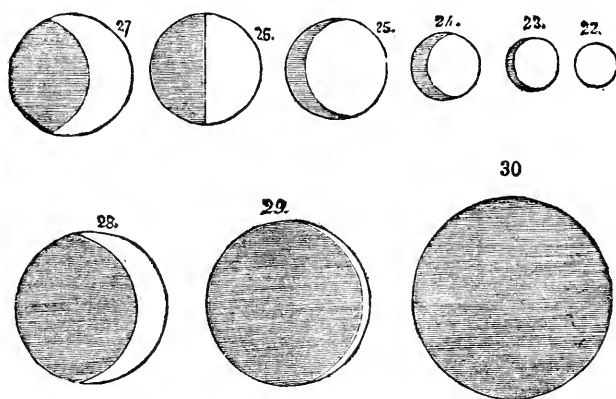

respecting this planet. The period of its revolution round the sun is in 224 days 16 hours, during which time it accomplishes a course of 434 millions of miles, at the rate of eighty thousand miles an hour. Its orbit is inclined to the ecliptic in an angle of three degrees twenty-three minutes and a half, and the eccentricity of its orbit is less than half a million of miles, or about the 1-276th of its diameter. On the ground of certain observations, it has been supposed that it is attended with a satellite; but such a body, if it exist, is seldom seen, and therefore its existence is considered as uncertain. In its elongations, it never removes farther from the sun than from forty-five degrees to forty-seven degrees. If its enlightened side were turned toward us when it is nearest the earth, it would present a surface twenty-five times larger than it generally does and shine with the splendor of a small moon; but, at that time, its dark side is turned to the earth. To an inhabitant of Venus, Mercury will appear as a morning and evening star, with more splendor than it does to us; and the earth, when nearest to Venus, will shine forth with a splendor nearly ten times greater than either Jupiter or Venus does to us. This planet, like Mercury, sometimes makes a transit across the disc of the sun. The last transit happened in 1769, and the next will take place on December 9, 1874, at eight minutes past four, a. m., which will be invisible in Britain, and in most European countries; but, as it is a phenomenon of great im-

portance in astronomy, British astronomers will doubtless, be sent to observe it in those countries where it will be visible. This beautiful planet, distinguished from all the other stars by its superior brilliancy, is occasionally alluded to by the sacred writers, as the "son of the morning"—"the day star," and "the bright and morning star;" emblematical of the Redeemer of mankind, giving light to the world after a long night of superstition and darkness, and of its cheering influence on the minds of sinful men, when the "day star" from on high hath arisen in their hearts. When viewing the bright luminaries of the sky, and especially the morning star, and when we consider the beautiful order and arrangement of these orbs, the placid influences they diffuse, and the harmony with which all their movements are performed, a contemplative mind can scarcely refrain from contrasting such scenes with the darkness and disorder which prevail in the moral world. While the sun diffuses his splendor by day, and the moon and the stars shed their mild radiance by night, it is still necessary to the happiness of our world that intellectual light and sacred joy should be diffused over the minds of its inhabitants—of which the light of these luminaries is designed to serve as an emblem. When the morning star makes its appearance near the eastern horizon, it is a sign that the sun will, ere long, arise, and that the darkness of night will soon be dispelled. When the "day star" arises

We shall state only the following additional fact

on the benighted mind, it intimates that gloom and darkness, with all their miserable accompaniments, formerly brooded over it; but now that the light of Divine truth has begun to irradiate the darkness, it is a sign that this light will still increase, and shine "more and more unto the perfect day," until at length it blend itself with the glories of the celestial world, where the "sun shall no more go down," where the Lord God shall be an everlasting light, and where the days of darkness and "mourning shall be ended."

## SECTION IV.

## THE EARTH: CONSIDERED AS A PLANETARY BODY.

(1.)—*General view of the Earth's surface, atmosphere, magnitude, and method of finding its dimensions.*

It may seem strange to some readers that this world on which we reside should be considered a planetary orb; as, at first view, it appears to bear no resemblance to any of the orbs that appear in our nocturnal sky. The planets, as they are seen in the heavens, by the unassisted eye, appear only as comparatively small points of light; whereas the earth, from whatever point it is viewed, appears the largest body our eyes can anywhere behold, and when we traverse its surface, either by sea or land, there appear no boundaries to its dimensions. From the positions in which we are permitted to view any portion of the earth—even when we ascend several miles above its surface in balloons—it exhibits no luminous aspect such as that which the celestial bodies present; so that, at first view, we might be apt to suppose that no similarity can exist between our sublunary world and the orbs of heaven. Beside, the celestial orbs are apparently in rapid motion from one region to another, while the earth, as a whole, appears to be at rest in the center of the celestial motions. Whether we sit in our apartments, or walk in the fields, we feel no motion in the solid earth which supports us, and are apt to imagine that the portion of the globe on which we dwell remains invariably in the same point of infinite space. We perceive no motions connected with our world but those which are produced by the rivers, the ocean, the atmosphere, and subterranean convulsions, and those which are the result of the various processes of the arts—the flux and reflux of the sea—the flowing streams—the roaring cataracts—the stormy winds—the waving forests—the ships moving on the face of the deep—and the steam-carriages, with their hundreds of passengers flying along the railway course. There is not, perhaps, one out of a thousand of the earth's inhabitants that has the least conception that—beside every other movement of which he is susceptible—he is carried along through the regions of infinite space with the rapidity of thousands of miles every hour. Yet this is a fact which is not merely probable, but certain, and can be demonstrated to the conviction of every one who is willing and qualified to enter into such investigations.

Could we take our station on the surface of the moon, we should behold the earth hanging like a great globe in the firmament, appearing with a surface about thirteen times larger than the moon does to us, and turning round its different sides to our eye—sometimes presenting the view of America and the Pacific Ocean, and at other times, Asia, Africa, Europe, and the Atlantic—sometimes appearing like a large crescent, or half moon, and

at other times with a full enlightened hemisphere. Were we placed on the surface of Venus, we should behold the globe on which we live appearing in the azure sky like a large, bright star, as that planet appears to us when an evening or morning star; and the moon, which appears so large in our firmament, would be seen only like a very small star, very near the earth, and constantly moving around it. At certain times, the earth would appear nearly ten times larger than Venus does to us, and would present the appearance of a small brilliant moon. Were we placed on the planet Mars, which is much farther from the sun than Venus the Earth would appear alternately as a morning and evening star, exhibiting different phases, as Venus does to us, but with a less degree of size and splendor. It might not, perhaps, shine with so much brilliancy as Venus, but it would probably appear with a luster similar to that which Mars presents to us. Nor need it be wondered at that the earth should appear as a luminous body from such distant positions; for we have demonstrative proof that Venus, Mars, and all the other planets, though they appear like shining orbs, are in reality dark bodies like the earth, and have no light of their own but what they receive from the sun; and it is only when the portions of their sides which are enlightened by the sun are turned to us that they are seen in the heavens. On some occasions, the dark side of Venus is completely turned toward the earth, and then she is invisible; and sometimes, when in this position, has been seen, like a dark spot, to pass across the face of the sun. These and other circumstances demonstrate that the planets are in themselves dark bodies, and shine only by reflection; and consequently that the earth, though a dark body, will appear to shine at a distance by reflecting the solar rays which fall upon it, as the moon does to us.

We have already proved, that, as a planet, the earth turns round its axis every twenty-four hours; and, in the sequel, we shall endeavor to show that it also moves round the sun in company with the other planets. In the meantime, we may take a brief view of the surface of our globe, which, in some of its features, may, perhaps, resemble those of some of the other planetary worlds.

When we cast our eyes around us, and take a general survey of the surface of the earth, thousands of objects present themselves to the view which demand attention. One of the most obvious and common arrangements which we behold in almost every country, is the verdant covering of the earth, which is formed by an assemblage of herbs, plants, shrubs, and trees of various shades, which diversify the landscape, and refresh the organs of vision; for there is no color so pleasing, and which refreshes the eye so much as the various shades of green. When we enlarge the circle of our view by traveling through different countries, we behold objects of a more grand and magnificent description; ranges of mountains, hundreds of miles in length, with their summits rising above the clouds, presenting a scene of rugged grandeur and sublimity; rivers, rolling their vast masses of waters, in courses of hundreds or thousands of miles toward the ocean, in which they are absorbed; the ocean itself, in its numerous windings, spreading its immense sheet of waters over more than half the globe, rising and subsiding at certain intervals, and forming a medium of communication between the most distant regions of the globe. In various regions of the earth, we behold expansive lakes and inland seas diversified with numerous islands, lofty and abrupt precipices, capes and promontories, dashing cataracts, unfathomable

caverns, rapid whirlpools, avalanches hurling down the declivities of lofty mountains, the icebergs of the polar regions, the luxuriant scenes of the torrid zone, and numerous volcanoes surrounded with smoke, and pouring forth from their craters, ashes, flames, red-hot stones, and streams of melted lava on the surrounding regions.

When we contemplate our globe in its largest and most general features, we find its surface divided from north to south by two large bands of earth, and two still larger bands of water, which exhibit a somewhat irregular appearance, presenting a number of wavings and indentations, and a great difference of breadth in different places. The first band of earth is the Eastern Continent, comprehending Europe, Asia, and Africa, the greatest length of which is in a line beginning about the northern part of Tartary, and extending to the Cape of Good Hope, or from A to B, fig. 31, which line measures about 10,000 miles from north-east to south-west. This body of land contains thirty-six millions of square miles, forming nearly one-fifth of the surface of the terraqueous globe. The other band of earth is the Western Continent, which comprehends North and South America. Its greatest length is in a line from the mouth of the river Plata, in South America, to the land beyond Hudson's bay, or from C to D. This line measures eight thousand miles; and the whole of this continent contains fourteen millions

specified, there are numerous extensive portions of land dispersed throughout the ocean, such as the islands of Madagascar, Sumatra, Borneo, New Guinea, Great Britain, Ireland, and hundreds of others.

Between the two large continents now stated, lie two immense bands of water, which are called the Pacific and the Atlantic oceans. The Pacific is at least 11,000 miles from north to south, and 10,000 miles in breadth from east to west. The Atlantic is about 3000 miles broad from east to west, and more than 10,000 miles in length from north to south. It lies between the western shores of Europe and Africa, and the eastern shores of America. The Pacific occupies the whole range between the western coasts of America and the eastern coasts of Asia, occupying nearly the one-half of the globe. The relative positions of these continents and oceans will be seen by an inspection of fig. 31, where it may be noticed that the projections of the eastern side of the American continent nearly correspond with the indentations of the western side of the eastern continent; so that, if we could conceive the two continents brought together, they would nearly correspond, so as to form one compact continent, with two or three small gulfs between them. The following are nearly the dimensions of the different oceans. The Pacific covers eighty millions of square miles; which is far more than the extent of all the dry land on the face of the earth. The Atlantic covers twenty-five millions; the Indian ocean, thirteen millions; the Southern ocean, twenty-five millions; the Northern ocean, five millions; the Mediterranean, one million; the Black Sea, 170,000 square miles; the Baltic, 175,000; the North Sea, 160,000. And if, as La Place has estimated, the tides demand an average depth of three miles, the whole ocean will contain 450 millions of cubic miles. The whole surface of the ocean, then, contains about 149 millions of square miles, which is more than three times greater than the surface of the land, which contains only forty-nine millions of square miles.

Around this vast body of land and water the Creator has thrown an atmosphere, or body of air, which is as essential to the existence and comfort of the living beings that dwell on its surface, as any other arrangement respecting our world. The denser part of this body of air extends to the height of about forty-five miles above the surface of the earth, but its density gradually decreases in proportion as we ascend into its higher regions; and at a certain height it is unfit for respiration and giving play to the animal functions. This atmosphere, though almost impalpable to our senses, is now ascertained to be a compound substance, composed of two very different and almost opposite substances, as to their qualities. One of its ingredients, which forms about four-fifths of the whole atmosphere, is of such a nature that no fire will burn in it, and if man or other animals breathe it, life is almost instantly extinguished. The other ingredient, which forms only one-fifth of the atmosphere, is the principle of combustion, and produces the most rapid and splendid deflagration of all combustible substances, and even a steel wire, made red hot, if plunged into this species of air, will take fire and burn with the utmost brilliancy. Animals might breathe it for some time without much annoyance; but it would soon waste the functions of the animal system. It is by an admirable combination of these two opposite principles that the air we breathe is constituted; and in this combination, the wisdom and goodness of our beneficent Creator is clearly ma-

Fig. 31.

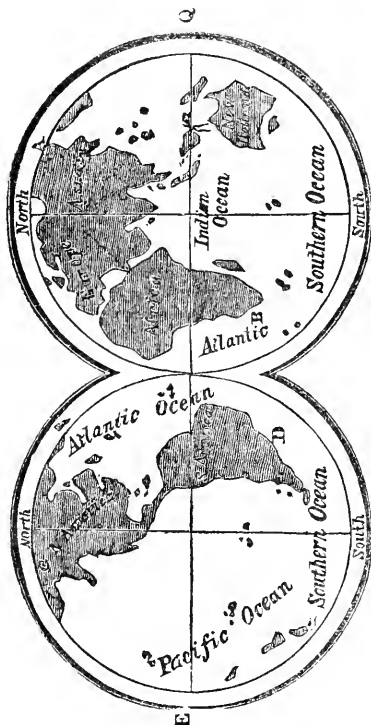

of square miles, being little more than one-third of the western continent. South-east of the western continent is a large body of land, which may be considered as a third continent; namely, New Holland, which is 2400 miles in length, and 1800 in breadth, and contains nearly three millions of square miles. Beside the bands of earth now

nifested; for had these principles been combined in a very different proportion, pain, suffocation, or death might have been produced in all animals that breathed it. It is in this atmosphere that the birds fly, and the clouds are suspended—where rain, hail, and snow are formed—where a portion of the ocean, of the seas, and of the rivers, is continually ascending, to form those clouds which water and fructify the earth—it is the medium in which whirlwinds rage, and lightnings flash, and thunders roll; and were it swept from the earth, or were its constituent principles materially changed, every living being would soon disappear from all the regions of earth, air, and sea. Were the Creator disposed to destroy the human race on account of their transgressions, he has only to extract one of the ingredients which compose the atmosphere which surrounds us, and the awful catastrophe is at once accomplished; so that, in his “hand is the soul of every living thing, and the breath of all mankind.” But his forbearance, in this respect, is a palpable evidence that he is “slow to anger,” “merciful and gracious,” “abundant in goodness,” and that “his tender mercies are over all his works.”

In regard to the *magnitude* of the earth, it may be stated that its circumference, or a line going quite round it, measures about 24,912 miles; and, of course, its diameter, or a line passing from one side to another through its center, measures 7930 miles,\* and the number of square miles on its surface is about 197 millions. It has been ascertained, by various experiments and measurements, that the earth, strictly speaking, is not exactly of the shape of a globe, but of an oblate spheroid, being somewhat flattened at the poles, and having its polar diameter about twenty-six miles shorter than the diameter passing through the equator. But the difference is so small, compared with the whole bulk of the earth, that though a spheroid were constructed of the exact shape of the earth, and fifteen feet in diameter, it could not be distinguished by the eye from a common globe.

To some readers it may appear somewhat strange that we should speak with so much confidence of the bulk and dimensions of the world we live in, which has never yet been completely explored; and they may, perhaps, wish to know how it is possible to determine its magnitude, figure, and other properties and relations. It must be confessed that to measure the earth, and determine its magnitude, and its exact figure, is one of the most wonderful enterprises which has ever been undertaken by man. How shall a creature, only six feet high, whose longest measures are yards, poles, and chains, be able to traverse every region of this great world, and measure its dimensions? His stature and his longest measures are, when compared with the whole earth, but as a grain of sand to a range of mountains. Beside, there are portions of the earth which have never yet been reached either by sea or land; and although he were to carry his measuring lines along with him, and extend them to furlongs, miles, and leagues, yet he could not go round the circumference of

the earth to obtain its exact measure. Mountains, rivers, seas, and oceans, and many other obstacles would be continual impediments in his way, and would soon put an entire stop to his progress, and the attainment of his object. But, notwithstanding such difficulties, man, by the exercise of his rational powers, and the knowledge he has acquired of the positions and motions of the heavenly bodies, has been enabled to determine, to a very near approximation, the exact dimensions of his earthly habitation, without putting himself to the trouble of traveling to the most distant regions, or even removing from the land of his nativity.

When the earth was ascertained to be nearly of a globular figure, and when the method was discovered of finding the distance of any place from the equator,\* or, in other words, its latitude, a foundation was laid for finding the circumference, and other dimensions of the globe. Every circle, or every circumference of a sphere, whether great or small, is divided into three hundred and sixty equal parts. This number, three hundred and sixty, is arbitrary, and any other number, such as four hundred, six hundred, or one thousand, might have been fixed upon; but mathematicians, in most countries, have fixed upon three hundred and sixty as the number of degrees or divisions in a circle; because, in the first place, it was formerly supposed to be about the number of days in a year, and in the next place, because it is a number that may be divided into halves, quarters, and eighths, without fractions. Now, in order to obtain the dimensions of the earth, it was only necessary that one degree on its surface should be accurately measured in order to obtain the whole circumference. To accomplish this, we must draw a meridian line—that is, a line that runs directly north and south, at any place we make choice of for the first station, and find the latitude or height of the pole at that particular place. We must then prolong the meridian line, either northward, until we come to a place where the latitude is exactly one degree more—or southward, until it is one degree less than at the first station. We must then measure the distance between these two places, in miles, leagues, yards, or any other known measures; and then we obtain the number of miles, etc., contained in one degree, or the three hundred and sixtieth part of the earth's circumference; and the number of miles, etc., contained in one degree, being multiplied by three hundred and sixty, gives the whole circumference of the earth. And when the circumference is obtained, the diameter may be found by the rule given in the preceding note (p. 35). And when the circumference and diameter are known, the number of square miles on its surface, and the number of cubical miles in its solidity may be obtained by an easy calculation. But although one degree accurately measured would determine the dimensions of the earth, yet more accuracy is obtained by measuring three, five, eight, or ten degrees, as has been done by several European nations.

On the general principle now stated, Mr. Richard Norwood, in the year 1635, attempted to find the circumference of the earth by measuring a meridian line between London and York. He

\* As the circumference of a circle or globe is found by mathematicians to bear a certain definite proportion to the diameter—when the one is known the other is easily determined by calculation. The proportion of the circumference of a circle to its diameter is nearly as 22 to 7—more accurately as 3.1416 to 1. Therefore, if we multiply the circumference by 7, and divide the product by 22, we obtain the diameter, nearly. And if we multiply the diameter by 22, and divide by 7, we obtain the circumference. But we obtain the result more accurately by multiplying the diameter by 3.1416, in order to obtain the circumference; and by dividing the circumference by 3.1416, to obtain the diameter.

\* The equator is a great circle of the earth, equally distant from the north and south poles, and divides the globe into two equal parts called the northern and southern hemispheres. From this circle the latitudes of places are counted, either northward or southward. It is represented by the line E Q, in fig. 31.

took the sun's altitude when in the summer solstice both at London and York, with a sextant of eight feet radius, and by that means found the difference of latitude between these two cities to be two degrees and twenty-eight minutes. He then measured their distance, in as exact a manner as possible; and having taken into the account all the turnings and windings of the road, with the ascents and descents, he reduced it to an arc of the meridian, and found it to contain 12,849 chains; and this distance being compared with the difference of latitude, gave 5,299 chains, or 367,200 English feet to a degree, which is equal to sixty-nine and a half miles and fourteen poles, and which was considered as a near approximation to the truth, according to which the circumference of the earth would be about 25,035 miles. Since his time, various admeasurements have been made of different parts of the earth's surface, from which its extent has been still more accurately ascertained. The French have measured a meridian line extending from Dunkirk to Formentara, an island in the Mediterranean, an extent of about eight degrees; and a trigonometrical survey, for the same purpose, under the direction of the British Government, has lately been extended over Great Britain. From all the admeasurements hitherto made, it appears that, on an average, a degree of the meridian may be reckoned at sixty-nine and one-fifth English miles; which makes the circumference of the globe 21,912 miles. It may just be noticed further, on this point, that, as the earth is not an exact sphere, but a spheroid, a degree of latitude must measure more in the polar regions than near the equator. From actual measurements, it has been found that a degree of the meridian in Lapland, measures six and a half English furlongs more than a degree at the equator.

## 2.—*Proofs of the annual motion of the Earth.*

We have formerly demonstrated the diurnal rotation of the earth, which causes the appearance of the rising and setting of the sun, moon, and stars. We now proceed to state very briefly some of those considerations or arguments by which it is proved that the earth revolves round the sun, as the center of the system, once every year.

In the first place, there are certain general considerations that render it highly probable, if not certain, that the earth must have a motion round the sun. If we admit the annual motion of the earth, then all the phenomena of the heavens, and the apparent irregularities of the planetary motions are completely accounted for, and the whole system presents a scene of unity, harmony, and order, worthy of the perfections and the plans of Him who is "the only wise God,"—who "hath established the world by his wisdom, and hath stretched out the heavens by his understanding." Whereas if the earth be supposed at rest in the center of the system, the order and harmony of the solar system appears completely destroyed, the motions of the planets present an inextricable maze, their phenomena cannot be accounted for on any rational principles, and no evidence of wisdom can be traced in the arrangements of the system to which they belong. Again, the sun is the fountain of light and heat for irradiating and cheering all the planets and other moving bodies of the system, and therefore it is necessary that this luminous orb should be placed in the center, from which position alone its rays can be distributed in proper proportions to all the worlds which revolve around it. Were the earth at rest

in the center of the system, and the sun and the planets revolving around it, as was formerly supposed, the planets would be at certain times at very different distances from the sun; and consequently, in one part of their orbits, they would be scorched with superabundant heat, and in another part frozen with insufferable cold. But from the center of the system the emanations of light and heat can be equally distributed to all the planets, whether primary or secondary; and the whole presents to view a system of harmony and order.

The following summary of arguments on this point—did our limits permit us to explain and illustrate them—would appear demonstrative to every one who is acquainted with the subject.

1. The planets Mercury and Venus are observed to have two conjunctions with the sun, but are never in opposition to that luminary, that is, they are never seen in the east, or opposite part of the heavens, when the sun has just set in the west. Now this circumstance could not possibly happen, unless the orbits of these planets lay within the orbit of the earth. If they revolved around the earth as a center, as the ancients supposed, they might frequently be seen in opposition to the sun.
2. The greatest elongation, or distance, of Mercury from the sun is twenty-nine degrees; and the greatest elongation of Venus, or the distance to which it ever recedes from the sun, is forty-eight degrees, which correspond exactly with the distances assigned them in the system; but if they moved round the earth as a center, they would sometimes be seen one hundred and eighty degrees from the sun,—a circumstance which was never observed either in ancient or modern times.
3. The planets, Mars, Jupiter, and Saturn, and all the other superior planets, have each their conjunctions with the sun, and oppositions to him, which could not be unless their orbits were exterior to the orbit of the earth.
4. In the arrangement of the planets—according to the system which places the sun in the center—they will all be sometimes much nearer the earth than at other times; and, consequently, their brightness and apparent diameters will be proportionally greater at one period than at another, which corresponds with every day's observations.\* But according to the system which places the earth in the center, their apparent magnitudes should always be the same, which is contrary to fact; the planet Mars, for instance, being in one part of its course, five times nearer the earth than in another, and consequently appearing twenty-five times larger in surface.
5. All the planets, in their movements through the heavens, are seen sometimes to move toward the east, sometimes toward the west; and at certain points of their orbits, they appear fixed for some time in the same position; all which diversities of apparent motion are the necessary results of the earth's annual motion, and are completely accounted for, when the sun is considered as the center of the system, and the earth as revolving between the orbits of Mars and Venus. But they are altogether inexplicable, on the supposition that the earth is at rest in the center of the system.
6. When the planets Mercury and Venus are viewed through good telescopes, they are found to assume different phases, in different parts of their orbits, sometimes appearing gibbous, sometimes like a half moon, and at other times like a crescent, or a full enlightened hemisphere—as formerly explained; which could never happen, if they revolved round the earth as their center, and if the earth were not placed in an orbit exterior to that of Venus. But

such phases are the necessary result of this position of the earth in the solar system. 7. The law discovered by Kepler, that "the squares of the periodic times of the revolutions of the planets are in proportion to the cubes of their mean distances from the sun," is a law which is established on the most accurate observations, and by which all the planets, both primary and secondary, are regulated. For example, Venus revolves round the sun in 224 days, and the earth in 365, and the mean distance of the earth from the sun is ninety-five millions of miles. Hence, as the square of 365=133,225, is to the square of 224=50,176, so is the cube of 95,000,000=857,375,000,000,000,000,000,000 to a fourth number, which is the cube of the mean distance of Venus from the sun. And if the cube root of this number be found, it will give about sixty-eight millions of miles for her real mean distance. But this law, which applies to all the heavenly bodies without exception, is completely set aside and destroyed, were the sun and planets to be considered as moving round the earth as the center of their motions. In short, were we to suppose the earth at rest in the center of the planetary system, the motions of all the planets would present a scene of inextricable confusion—a scene of such disorder and confusion, as would puzzle not only man, but the most intelligent archangel to account for, and to explain in consistency with the perfections of a Being of infinite wisdom and intelligence.\*

The most complete and sensible demonstration of the annual motion of the earth is furnished by Dr. Bradley's discovery of "the aberration of the light of the fixed stars." In endeavoring to determine the annual parallax of the stars, he discovered that they are not motionless, but that, during the time the earth takes to traverse its orbit, such of them as are in a plane perpendicular to this orbit, appear to describe circles. This is the phenomenon called "the aberration of light," which is found to be the motion of light combined with the progressive motion of the earth in its orbit, which causes the stars to be seen in a different position from what they would be if the eye were at rest. But as the explanation of this phenomenon would require some minute details, and several figures for its illustration, and as it might not be understood by general readers, we will defer in the meantime from entering upon any further statements. We may just remark, that the fact of the aberration of the stars exhibits the motion of the earth to our senses as clearly as if, from a fixed point in the heavens, we actually beheld it pursuing its course through the ethereal regions.

It is of importance that we acquire clear and convincing views on this subject, in order that we may entertain correct and honorable conceptions of the perfections of the Creator, and of the wisdom and intelligence displayed in the arrangements of his works. For, in all cases, we judge of the character and perfections of the designer and workman from the qualities and perfections which appear in their works. If we view the works of the Almighty through a distorted medium, we shall be apt to entertain incorrect and distorted views of the attributes of Him who designed and formed them. If we view the earth as at rest in the center of creation, and the sun,

moon, planets, comets, and stars—in other words, the whole universe—revolving around us every day, with motions so rapid as to exceed all calculation and comprehension; or if we suppose the planets moving backward and forward without any order, and presenting in their motions a series of looped curves and mazes without any marks of design, and exhibiting a scene of inextricable confusion; we should scarcely be led to entertain high and honorable conceptions of the wisdom of Him who formed such arrangements; for the marks of Divine intelligence, on such suppositions, would nowhere appear. Whereas, in the true system of the universe which science has laid open, the marks of wisdom and intelligence, harmony and design, are everywhere apparent, and present a scene of operation worthy of the perfections of Him who "established the world by his wisdom," and whose "understanding is infinite." Hence the necessity of acquiring correct views of the works of creation and providence, and of the arrangements which exist in reference to our world, and to the universe around us; for upon such views our conceptions of the great object of our adoration will, in a great measure, depend. When, therefore, we obey the Divine command and "lift up our eyes on high, and behold the wonders of Almighty Power," and "stand still and consider the wonderful works of God," we are to contemplate them, not through the mists of ignorance, or vulgar prejudice, nor with the vacant stare of a savage; but with the eye of a Christian philosopher, and through the light which modern science has diffused over the wonders of creation; and the more we contemplate them in this light, the more clear and expansive will our conceptions be of the attributes of the "high and lofty One who inhabiteth eternity," and who presides over all the movements of the universe.

(3.)—*Phenomena arising from the annual motion of the earth.*

In the first place, if the earth revolve around the sun once every year, it is evident that the sun will appear to make a revolution round the heavens in the same period. In fig 32, let S repre-

Fig. 32.

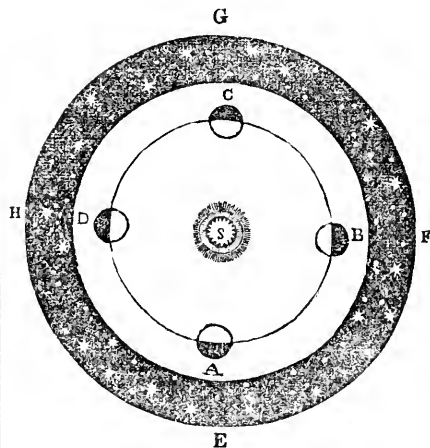

sent the sun at rest in the center, and A B C D the earth in four positions; and let us suppose the earth to move in the order of the letters A B C D;

\* Those who would wish to see a full illustration of the above arguments are referred to "Celestial Scenery, or the Wonders of the Planetary System Displayed;" [Vol. II, Book 2, of this edition,] where the same and several other arguments are illustrated in minute detail, and by reference to engravings.

It is evident that when the earth is at A, the sun will appear in that part of the heavens where the stars at G are situated. When the earth has moved to B, the sun will appear to have moved to the stars opposite H; and in like manner, when the earth has moved to C, the sun will appear opposite to E; and when it has moved to D, the sun will appear at F; after which it will again appear at G, when the earth has moved to A. And as the earth revolves around the sun in the orbit A B C D, so the sun will appear to a spectator on the earth to describe the circle in the heavens E F G H. Hence it is that we see the sun gradually proceeding in his course round the concave of the sky from west to east at the rate of nearly one degree every day, through the twelve signs or constellations of the zodiac; and at the end of a year, he returns to the same point from which he set out. Hence also it follows, that if the plane of the earth's orbit be imagined to be extended to the heavens, it would cut the starry firmament in that very circle in which a spectator in the sun would see the earth revolve every year, while an inhabitant of the earth would observe the sun to go through the same circle in the same space of time. This circle is called the Ecliptic, or the apparent path of the sun through the heavens. And, although the path of the sun, and the particular stars he is passing along, cannot be seen in the day-time, yet, from observing the stars that are directly opposite to him at night, we can tell at any time what particular stars the sun is passing along in every part of his course.

The inhabitants of all the other planets will perceive similar motions in the sun as we observed, but performed in different periods of time, according to the times of their annual revolutions. For example, an inhabitant of Jupiter would see the sun apparently revolving around him, describing a circle in the heavens in the space of twelve years. This circle would not be exactly the same as our ecliptic, because the orbit of this planet is somewhat inclined to the orbit of the earth; but it would pass very near it. In the course of one of our years the sun, from Jupiter, would appear to pass through only a twelfth part of the circumference of the heavens. The sun from Saturn will appear to move in another circle in twenty-nine years and a half; and a spectator in Venus will see the sun moving in a circle different from all these, with greater apparent rapidity, in the space of seven and a half months. All these apparent motions of the sun arise from the real motions of the respective planets.

In the next place, the annual revolution of the earth shows the reason why we behold one set of stars in our firmament at one season of the year, and another set of stars at a different season. For example, in our latitude, the stars, and constellations which are seen during the winter months, in the south, are altogether different from those which are seen in summer; and those stars which surround the pole in the north, and which never set, if they are below the pole in winter, they will be seen as far above the pole in summer. At the equator, where all the stars rise and set, the stars which appear in the middle of winter are all completely different from those which are seen at the same hour in the middle of summer. This is easily explained by the preceding diagram (fig. 32), in which the earth, in four situations in its orbit, appears half enlightened and half in the dark, representing day and night. When it

is at A, the sun will appear at noon at G, and obscure all the stars in the hemisphere F G H; whereas at midnight the point of the heavens E will be in the meridian, and all the stars in the other hemisphere F E H will be visible. Three months afterward, when the earth comes to the situation B; the sun at noon will be seen at H, and all the heavens G H E will be day, illuminated by the sun; and over all the other half E F G, the stars will shine at night. Consequently, the stars in the quarter F G will now be visible, which in the former position were obscured by the sun, and those in the quarter H E, formerly visible, will become obscured by day-light. In like manner, when the earth is at C, the heavens H E F will be day, and F G H night, where all the stars which were obscured, when the earth was at A, will now be visible. And, lastly, when the earth is at D, the stars and constellations in the hemisphere E F G, will be obscured by the light of the sun, and those on G H E will be visible during the night. Hence, every one who is accustomed to look at the heavens will have observed that the bright constellation Orion, the brilliant star Sirius, which follows it, and the Pleiades, or seven stars, which are visible in the southern part of the firmament during winter and the approach of spring, are never seen during the summer months, because the sun is then illuminating that portion of the heavens where they are situated; but they may be seen in the day-time by means of equatorial telescopes.

(4.)—*On the destination of the earth, or the final cause of its creation.*

In the creation of the material universe, the Creator must have had some grand designs in view, beside the mere formation of immense globes of matter and setting them in motion and arranging them into systems. In so far as we are able to penetrate, it appears demonstrable that matter exists chiefly, if not solely, for the sake of sentient and intellectual beings. This evidently appears to have been the chief design for which our globe was created; and we have the strongest reason to conclude that this was the main end for which all the other planetary globes belonging to the solar system and to other systems, were brought into existence. Hence it is declared in the sacred oracles, when reference is made to the formation of our globe, "God formed the earth and made it;—he created it not in vain; he formed it to be inhabited;" which evidently implies, that to have created it without the design of its being inhabited, would have been an instance of folly inconsistent with the perfections of Him whose wisdom and intelligence are infinite; and the same reasoning will apply to all the other planets, which appear to be furnished with every accommodation adapted to sensitive and intellectual enjoyment.

In peopling the earth and other globes with inhabitants, the Creator evidently intended to give a display of his perfections to beings capable of contemplating it, and to promote their sensitive and mental enjoyment. The happiness of his creatures must have been one grand design which the Creator had in view, when he breathed into them the breath of life, and made them rational and immortal beings. Accordingly, we find that when man was at first placed upon this globe, everything that was beautiful to the eye and the imagination, and pleasant to the taste, was prepared for his accommodation and comfort. The waters were separated from the dry land—the earth was



adorned with verdure—rivers and refreshing streams flowed around him to increase his pleasures—trees, and plants, and flowers of every form and hue diversified and embellished the landscape. Light was formed, and celestial luminaries appointed to diffuse its radiance—a canopy was thrown around his habitation adorned with thousands of shining orbs, to elevate his contemplations to other provinces of his Creator's dominions—every plant and tree yielding delicious fruit was provided to gratify his taste, and afford him sustenance; and all the inferior ranks of sensitive existence were placed under his dominion. One chief design of the Almighty, in these arrangements, was to show man his dependence, to make him an adorer, and a being capable of knowing and honoring his Creator and bountiful Benefactor. He gave him a law which implied supreme love to his Maker, and obedience to his will; and as an external sign of his obedience he said to him: "Behold all the trees of the garden in which I have placed thee; of every one of them thou mayest freely eat—only thou shalt forbear eating the fruit of the tree of knowledge." This reserve—which has been so frequently objected to—did in reality constitute the chief glory of man. None of the inferior animals knew their origin or their Benefactor, they could give no testimony of gratitude, nor could they exhibit any shadow of religion. Man alone was elevated to a rank, and endowed with faculties so as to know to whom he is indebted for all his enjoyments—and he alone was taught to express his gratitude to the Giver of all good! This constituted the true glory of man, and his superiority over all the other tribes of sensitive existence. It was a great and honorable prerogative conferred upon him to be able to obey his Benefactor, and to adore the hand which had loaded him with blessings: and therefore it was proper that a visible emblem of his obedience, or the contrary, should be continually before his eyes. The supreme Creator stood in no need either of the fruit of a certain tree, or of the opinions or sentiments of man respecting it. But it was fit that man should make an express profession of his gratitude and veneration: and therefore the sole exception which God made in his first transaction with man, was at once the memorial of his gratitude, and the public expression of his piety and submission to the divine will.

But we know that man did not remain in his primeval state of innocence and happiness, but by his disobedience "brought death into the world, and all our woe." For proof of this position, we have no need to enter into long trains of reasoning, or even to appeal to the records of revelation. The fact of man's fall and disobedience is written on the whole history of our world from the earliest ages to the present time. For what does the history of all nations chiefly record? It presents to our view little else than wars and commotions, contentions, and animosities, and "garments rolled in blood." One nation rising up against another, carrying fire and sword, and all the engines of destruction into a peaceful territory—laying waste provinces, burning cities, turning fruitful fields into a wilderness, and slaughtering, with diabolical fury, thousands and tens of thousands of their fellow-men. This has been one of the chief employments of all the tribes and nations that have ever dwelt on the face of the earth; and this fact, of itself, is a sufficient proof that man is no longer in his primeval condition of paradisaical innocence and rectitude, but is fallen from his high estate, and his glory turned into shame. We trust there is not another instance of creatures

endowed with rational faculties, and formed after the Divine image, acting in this way, to be found among all the other worlds of the universe. And were we not accustomed to witness such infernal passions and atrocities, and to behold men glorying in that which is their shame, we should be filled with utter astonishment and wonder that such horrible actions should be perpetrated on each other by brethren of the same family, children of the same Father, and beings destined to an immortal existence.

But the benevolent Father of all did not intend that this moral derangement should be universal and perpetual. As soon as man had fallen from his allegiance to his Maker he displayed his character as a God of mercy, and ready to forgive. He declared that the seed of the woman should bruise the head of the serpent—that an illustrious Messenger, invested with Divine power and authority, should be sent into the world at a proper time, to repair the ruins of the fall; "to finish transgression, and to make an end of sins;"—to bear the sins of many, and make "intercession for the transgressors." Preparatory to the advent of this Divine Messenger, certain families were selected in which the knowledge of the true God might be preserved—a certain nation, before whom astonishing miracles had been displayed, was chosen as the depository of Divine revelations—a ceremonial worship was instituted, prefigurative of the events and blessings of Messiah's reign; prophets were raised up to announce the coming of the great Deliverer, and the glorious results of his administration—the events of Divine Providence toward the nations were overruled and directed in such a manner, as to bring about the advent of the promised Messiah in all the circumstances which prophets foretold, and which God had appointed; and, when the predicted period had arrived, a retinue of celestial messengers was dispatched from heaven to earth to announce the appearance of "the Son of the Highest," of the increase of whose government there should be no end, and to proclaim "glory to God in the highest, and on earth peace, good-will toward men." And when this Deliverer appeared on the public theater of the world, he exhibited the most convincing proofs of his Divine mission by the most astonishing and beneficent miracles, displaying his power over the laws and the elements of nature—the spirits of darkness and the disorders of the human frame—"healing all manner of sickness and disease;" causing the deaf to hear, the blind to see, the lame to walk, and the tongue of the dumb to sing—raising the dead to life, and recalling the departed spirit from the invisible world. And, at length, when the great Sacrifice for the sins of men was about to be offered, a series of the most august and striking supernatural events attended its accomplishment—the sun was clad in black, the heavens were arrayed in sackcloth, darkness for three hours covered the whole land, the vail of the Jewish temple was rent in twain from the top to the bottom, the earth trembled and shook, the rocks rent asunder, the graves were opened, and many bodies of saints that slept in the tombs arose to life. On the third morning after this solemn scene, the "Prince of Peace" arose victorious from the grave, showed himself openly to competent witnesses of his resurrection; and afterward, rising above the confines of this earthly ball, winged his flight on a resplendent cloud, attended by myriads of angels, through distant regions which "eye hath not seen," and entered into heaven itself, there to "appear in the presence of God for us."

In consequence of these astonishing and benevolent arrangements, all men, everywhere, are now commanded to repent, with the full assurance that they shall obtain pardon, peace, and reconciliation, and every blessing requisite for their happiness in the present world and in the life to come. For thus runs the message of the Most High to all the children of men: "God so loved the world, that he gave his only begotten Son, that whosoever believeth in him should not perish, but have everlasting life." "Whom God hath set forth to be a propitiation through faith in his blood, to declare his righteousness for the remission of sins." "This is the record, that God hath given to us eternal life, and this life is in his Son." These announcements are made to all the inhabitants of this world, however vile, and however atrocious the deeds they may have committed—to the ferocious warrior that has slaughtered thousands, and to those who have long wallowed in the mire of depravity and licentiousness, as well as to those who have manifested some external decency of conduct. For He who is exalted as a Prince and a Saviour "is able also to save them to the uttermost that come unto God by him." And if we believe the record of God, and rest upon it as the declaration of a faithful Creator, we shall endeavor "to abound in all the fruits of righteousness"—to cultivate love toward God and toward man—"to add to our faith virtue, knowledge, temperance, patience, brotherly kindness, and charity," and every other Christian disposition and virtue which will tend to prepare us for the intercourses and employments of that higher sphere of existence where all is peace, and harmony, and love.

One reason why the benevolent arrangements which have been made for the happiness of man have been so long kept hid from the greater part of the world, and moral evil has been permitted to abound, doubtless is, that an extensive and impressive display might be given of the dismal and miserable consequences which necessarily flow from refusing allegiance to the Most High, and from a violation of his laws—to serve as a warning not only to the inhabitants of our globe, but to the inhabitants of other worlds of the necessity of submitting to the will of the Supreme, and of the inevitable disastrous effects which flow from the prevalence of moral evil. For if the fundamental laws of heaven—love to God and to man—were to be reversed, or universally violated, misery would pervade the whole moral universe, although it consisted of millions of worlds; and happiness could never be enjoyed by any rank of intelligent existence. But, however dismal a scene may have been presented to view, in the ages that are past, we are assured that a period is approaching—foretold by inspired prophets—when the world shall be regenerated, when "wars shall cease even to the end of the earth;" when violence and oppression and all unrighteousness shall be undermined and destroyed; when "the kingdoms of this world shall become the kingdoms of our Lord, and of his Christ;" when "every one shall sit under his vine and fig-tree," without the least fear of annoyance; when "the earth shall be full of the knowledge of the Lord, as the waters cover the sea," and "the Lord God will cause righteousness and praise to spring forth before all the nations." Then the antipathies of nations shall be destroyed; "the earth shall yield her increase;" its desolate wastes shall be cultivated, and its ruins restored, and all people "shall dwell in a peaceable habitation and in sure dwellings, and in quiet resting-places." And when the pur-

poses of Divine Providence shall have been fulfilled in regard to the present state of our globe, its constitution shall be changed, its elementary parts dissolved; and "new heavens and a new earth" shall arise wherein righteousness shall forever dwell. Such is the destination of our world, and such are the arrangements which its Creator has made in reference to its inhabitants.

Some readers may, perhaps, be disposed to say, "What has all this theological dissertation to do with astronomy? we do not see that it has any connection with a description of the solar system." On this point we beg leave to differ from such objectors. What is the material universe, when separated from its reference to the Creator, and its relation to intelligent beings? A mere machine, which displays nothing but uncontrollable power acting at random, without the least trace of wisdom, benevolence, or rectitude. To view the planetary system, or other systems, as consisting merely of a number of large globes, wheeling round their axes, and round their suns, in certain periods of time, is to overlook some of the grandest and most interesting objects of astronomy. To suppose all the orbs of heaven to be self-existent and self-moving is absurdity and atheism: and to suppose the Creator to have formed them merely as so many august and splendid pieces of machinery, without any relation to intellectual natures, is inconsistent with every idea we ought to form of the attributes of the Divinity. The relation of the material system to intellectual beings ought, therefore, to be connected with astronomical investigations. We know not, indeed, the physical and moral characteristics of the inhabitants of Venus, Jupiter, or other planets; but we know, for certain, that if they be in a state of primeval innocence and happiness, they obey the two grand principles of the law prescribed to the inhabitants of our world—"Love to their Creator, and love to one another," without the observance of which precepts, true happiness cannot be enjoyed in any world in the universe, and the whole material creation would be nothing else than a boundless Pandemonium. We know that these precepts have been generally violated in our world; and hence the wars, devastations, insurrections, systems of oppression and iniquity, and other evils, which have produced so much misery and wretchedness among the population of our globe. And shall it be considered as improper and unphilosophical, that, in describing the material fabric of the world, those arrangements which the Almighty has formed for the regeneration of society, and the happiness of the human race, should be occasionally adverted to and detailed? We must demur to such a sentiment. Philosophy has been too long dis severed from its connection with religion—to which it ought ever to be allied; and it is now high time that every department of human knowledge should be studied in connection with the moral arrangements of the Almighty, the renovation of the world, and the eternal destiny of man. The sciences, when disjoined from such connections, lose the greater part of their value, and can be considered as useful only in reference to the concerns of this world, and the transitory duration of the life of man. Whereas, when studied with right views, and in all their legitimate connections and relations, they bear an intimate relation to the Divinity, to the progress and expansion of the human mind to other worlds, and to the scenes and employments of an immortal existence.

In reference to the earth, we shall now only state the following circumstances: The number

of inhabitants which people the earth at one time is estimated at eight hundred millions—of these, five hundred millions are reckoned to Asia; fifty-eight millions to Africa; forty-two millions to America; and two hundred millions to Europe. Of these assemblages of human beings, twenty-five millions die every year, sixty-eight thousand every day, two thousand eight hundred and fifty every hour, and forty-seven every minute; so that at almost every pulse that beats within us, an immortal being is passing from time into eternity, from this visible and material world to another scene of existence—a solemn and important consideration to every one of us who must shortly follow, in our turn, the generations that have gone before us. If we reckon thirty-two years as the average period for a generation, as has been generally done—at the end of which period the whole human race is renewed, with a few exceptions; it will follow, that one hundred and forty-six thousand two hundred millions of human beings have existed on our globe, since its present arrangement commenced, reckoning 5849 years from the formation of Adam to the present time. But if we make our estimate according to the Samaritan and the Septuagint chronology, 7256 years are to be reckoned from Adam to the present time; and consequently, if mankind had never died, there would have been, at present, on the surface of the globe, 182,800,000,000; that is, one hundred and eighty-two thousand eight hundred millions of human beings. Whether the earth would have furnished subsistence for such a population is left to Malthusians and political economists to determine. But it appears, in point of fact, that the Creator never intended that such a number of the human species should remain on the earth at one time, in its present state; though it might easily be shown, that were all the habitable parts of the globe properly cultivated, it would support at least sixteen thousand millions of human beings, or twenty times the number that now exist on its surface, while each family would have an estate of twelve acres of land for its support. But the inferior tribes of animals are far more numerous than the amount of all the human inhabitants that have ever dwelt on the earth, from Adam to the last new-born child. At a rude calculation, the inferior tribes connected with the air, the waters, and the dry land, at one time, cannot amount to less than thirty billions of living beings; which is 164 times the number of all the human beings that have ever appeared on the earth. As one instance out of many of the immense numbers of certain species of animals, we may mention what Mr. Wilson states, in his "American Ornithology," that a single flock of the migratory pigeon of the United States was found to be about a mile in breadth and 240 miles in length—having occupied four hours in passing across the country; which flock, by a moderate calculation, was estimated to contain two thousand two hundred and thirty millions, which is nearly three times the human population of the globe.

We may just further make the following statements in reference to the earth. In its course round the sun, it moves in an elliptical orbit, the longer diameter of which is 3,236,000 miles greater than the shorter, and consequently it is nearer the sun at one season of the year than at another. The time of its annual revolution is 365 days, 5 hours, 48 minutes, 49 seconds, which is called the tropical year; but the time it takes in moving from a fixed star until it returns to it again is 365 days, 6 hours, 9 minutes 12 seconds,—which is

called its sidereal year. With regard to the density of the earth, it is found to be about five times denser than water; so that could we suppose five globes as large as the earth composed of water, suspended at one end of an immense balance, and the earth at the other, they would nearly counterpoise each other.

## SECTION V.

## ON THE MOON.

THE moon is the nearest of all the celestial bodies to the earth, and is its constant attendant during its revolution round the sun. It belongs to that class of bodies called secondary planets, or satellites. A primary planet is one which revolves around the sun as its center: a secondary planet is a body which revolves around a primary planet as its center of motion, and is at the same time carried along with its primary around the sun.

*Motions of the Moon.*—The moon has an apparent motion round our globe every day, somewhat similar to that of the sun. She rises in an easterly direction, and, after a certain number of hours, sets in the western quarter of the heavens; this motion is not real, but only apparent, and is caused by the diurnal motion of our globe from west to east. The real motions of the moon are as follows:—In the course of 27 days, 7 hours, and 43 minutes, the moon makes a progress through the ecliptic, or round the whole heavens, from west to east, and returns to the same stars from which she set out. This is called her tropical revolution. The period from one new moon to another, or from one conjunction with the sun to another—which is 29 days, 12 hours, 44 minutes, and 2 seconds, is called her synodic revolution. The reason why these periods are different is this: at new moon, the sun and moon are in the same part of the heavens; but by the time the moon has returned to that point—namely, 27 days, 7 hours, 43 minutes—the sun has proceeded, in his apparent course through the heavens, twenty-seven degrees farther to the east, and is still going on, and the moon has to overtake him before she can be again in that position which is called new moon.

Fig. 33 exhibits some of the motions of the moon in relation to the earth and the sun. The

Fig. 33.

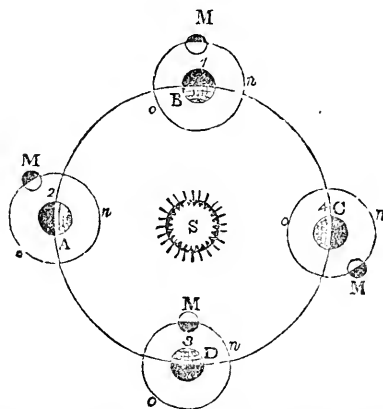

small circle, S, represents the sun; the circle A B C D, the earth's orbit and the earth

in four different positions. The smaller circle *M n o*, represents the orbit of the moon in its course round the earth. Around this orbit she moves, in a period somewhat less than a month, at the rate of 2300 miles an hour. But while she is thus carried, monthly, around the earth, she is also carried forward along with the earth, in its revolution round the sun. For example, while the earth has moved from *B* to *A*, the moon has made more than three revolutions round the earth, and at the same time has moved, along with the earth, nearly one hundred and fifty millions of miles, or the fourth part of the earth's annual circuit; so that the moon's motion through space is much more rapid than that stated above, and cannot be estimated at less than 70,000 miles an hour. When the earth is at *B*, in the position marked *1*, and the moon at *M*, the enlightened side of the moon is turned to the dark side of the earth, and the moon is in the position we call full moon, the whole of its enlightened surface being then turned toward the earth. When the earth is at *D*, and the moon in the position marked *3*, the dark side of the moon is turned toward the earth, and she is consequently invisible. This is the position of new moon. In the manner now described, does the moon revolve round the earth, and is carried along with the earth round the sun, from one year and one century to another; and has done so ever since she was appointed to give light to the earth, and "to rule the night." And since she is acted upon by two forces—the attraction of the earth and the attraction of the sun, which sometimes act in opposite directions—her motions are very irregular; which renders it somewhat difficult and tedious to calculate her precise position in the heavens at any particular moment of time.

*Phases and general appearances of the Moon.—*

The sun always enlightens one half of the moon; and sometimes the whole of this enlightened side is turned toward the earth, when she appears a round luminous orb: but this happens only in one point of her orbit. At all other parts of her course, only a portion of her enlightened hemisphere is seen from the earth; and in one particular position in her orbit, her enlightened side is altogether invisible. When she is at the change, or the period of new moon, she is invisible; both because she is in the same part of the heavens as the sun, and because the whole of her dark hemisphere is then turned to the earth. After this it is generally two days, or more, before any part of her enlightened surface is visible. About the third day after the change, she is seen in the western sky, at no great distance from the point at which the sun set, and then appears under the form of a slender crescent, with its horns pointing toward the east. Next evening, about the same hour, she will have moved about thirteen degrees farther to the east, and her crescent will appear to have increased somewhat in breadth. Every succeeding night she will appear to have moved still farther to the east, while her crescent is still increasing in breadth and luminosity, until about the eighth day from the change, when she appears in the form of a half moon. She is then about ninety degrees from the sun. After this period, still proceeding eastward, she assumes a gibbous phase, until she arrives at the period of full moon, when her whole enlightened hemisphere is turned toward us; which happens on the fifteenth day after the time of the new moon, when she is in opposition to the sun, or one hundred and eighty degrees distant, and rises about the time when the sun sets. On a cloudless night, she then displays to every beholder

a delightful and magnificent spectacle, calculated to arrest the attention of every eye, and to inspire the soul with emotions of sublimity. But she does not remain long in her full orb'd luster; she gradually loses a portion of her brightness, by presenting to us a part of her dark hemisphere. She again appears for a few days in a gibbous phase; afterward she assumes the appearance of a half moon, and then that of a crescent whose horns are now turned toward the west. In this position she is seen only in the mornings before sunrise; and in a few days afterward, she is in conjunction with the sun, when her dark side is again turned toward the earth. All these changes are accomplished in twenty-nine days and a half.

These phases are more particularly represented in fig. 34, where *S* represents the sun, *E* the earth, and *A B C D F G H I* the moon in different parts of its circuit round the earth, with its hemisphere turned toward the sun fully-enlightened. When the moon is at *A*, its enlightened side being turned to the sun, its dark side is turned toward the earth, and were it then visible, it would appear as at *K*, in the outer circle; but it is never visible in this position, except at the time of an eclipse of the sun, when its body, either in whole, or in part, interposes between us and the sun. This is at the period of new moon. When the moon has moved from *A* to *B*, a portion of its enlightened surface is then turned to the earth, and it appears as a crescent, as represented at *L*; when arrived at *C*, the one-half of its enlightened hemisphere is turned to the earth, and it appears in the form of a half moon, as at *M*; when arrived at *D*, it presents a

Fig. 34.

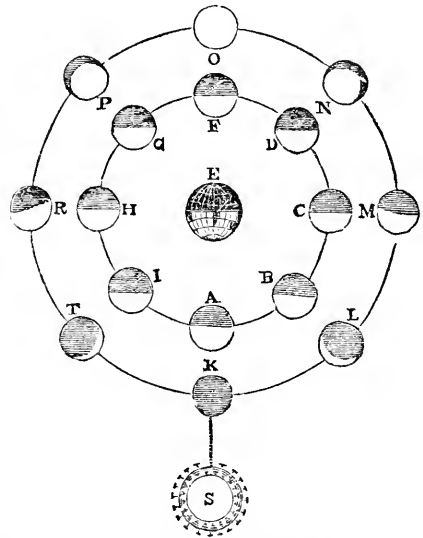

gibbous phase, as at *N*; and when arrived at *F*, it shines in all its splendor as a full moon, as at *O*. After this period it gradually declines, first to a gibbous phase, as at *P*; next to a half moon, as at *R*; then to a crescent, as at *T*; after which it arrives at its former position at *A*, the period of new moon; when it is again invisible.

*How the earth appears to the inhabitants of the Moon.—*We have now seen the cause why the moon presents so varied appearances to the earth; let us now consider how the earth itself will appear as viewed from the surface of the moon. Could

we take a view of the earth from one of the mountains, or plains, of the moon, we should find that it exhibits the same changes or phases, that the moon does to us, but in a reverse order. For when, at new moon, the dark side of the moon is turned toward us, the whole of the enlightened hemisphere of the earth is then turned toward the moon. And as the hemisphere of our globe is thirteen times larger than that of the moon, it will present in the lunar firmament a shining orb as large as thirteen of our full moons, and will therefore, diffuse a considerable degree of luster in the absence of the sun. That the earth shines with a full enlightened face upon the moon at the period now stated, will appear from the preceding diagram, fig. 34. At A, the moon is in conjunction with the sun, as seen from the earth, and its dark side is turned toward us; but it will be perceived that, at that time, the enlightened side of the earth, E, is completely turned toward the moon, so that while she is invisible to us, our globe appears in its full orb'd majesty and brightness to the lunar inhabitants. On the other hand, when the moon is at P, when it is full moon to us, the dark side of the earth, E, is turned toward the moon, and is consequently invisible to the inhabitants of the moon, being then nearly in the same part of the firmament as the sun. When the moon is increasing to us, the earth is diminishing in its illuminated surface to the moon. When the moon is at B in its increase, the earth appears as at P; when she appears as a half moon as at M, the earth appears a half moon in the decrease, as at R; and when she increases to a gibbous phase as at N, the earth has decreased to a crescent, as at T; so that the phases of the earth, as seen from the moon, are exactly opposite to those of the moon as seen from the earth.

That the earth actually shines upon the moon, and illuminates its surface as the moon does that of the earth, is proved from the following circumstance. On the second or third day after new moon, when she appears as a slender crescent, we perceive a faint light on the dark part of the moon which is not enlightened by the sun, so that the whole hemisphere of the moon is visible—one part faint, and the other bright. This is perceptible even by the naked eye, but it appears pretty vivid through the telescope when a small power is applied, so that many of the principal spots of the moon may be distinctly perceived. This may be termed the "moonlight of the moon," as the earth is then shining upon its surface with nearly a full enlightened hemisphere. This light on the dark side of the moon gradually decreases, as the enlightened part of the moon increases, because the enlightened portion of the earth is at the same time diminishing, so that its effect is not much perceived after the period of half moon. It has been sometimes observed that a brighter reflection proceeds from the moon when the continental parts of the earth are opposite to her than when the Atlantic or Pacific ocean is in the same position. There is less light reflected from the sea than from the land upon the moon, and therefore it is natural to suppose that when the hemisphere of the earth which contains Europe, Asia, Africa, and New Holland, is shining upon the moon, a considerably greater quantity of light will be reflected on her surface than when the Pacific ocean, which covers nearly half our globe, is directly opposite to her. In the course of the diurnal rotation of the earth every part of its surface in succession will be presented to the moon; and therefore it will appear to a lunar inhabitant with different degrees of brilliancy, at different times,

arising from the circumstances now stated. (See fig. 31, p. 34.)

The moon always presents the same side to the earth, so that we never see its opposite hemisphere. This circumstance proves that she turns round her axis in the same time she takes to move round the heavens. If the moon had no motion round her axis, we should see both her hemispheres in the course of every revolution she makes round the earth. Whether the other side of the moon be less adapted for reflecting light than that which is next us, or whether it be equally diversified with mountains, caverns, and plains, we have no opportunity of determining; though, reasoning from analogy, we may conclude that the arrangements of nature in that hemisphere are not essentially different from those we perceive in the hemisphere presented to our view.

There is a peculiar appearance which may be noticed, that the earth will present to an inhabitant of the moon, and it is this—that from any particular spot on the lunar surface, the earth will appear in a fixed position in the heavens, without any apparent motion. To those who live in the middle of the hemisphere next the earth, the earth will appear as a large globe in the zenith, or point directly above their heads, sometimes appearing as a half moon, a crescent, or a full enlightened hemisphere, and sometimes invisible, but always in the same position. The only motion they will occasionally perceive is the earth's rotation, which they will observe as the different continents, islands, and oceans of our globe present themselves in succession. Those who live near the margin of the moon's hemisphere next the earth, will see the earth near the horizon, and it will never appear from such places in a more elevated position in the heavens. Those who live in intermediate positions will behold the earth at higher or lower elevations, according to their distance from the center of the hemisphere. All these appearances necessarily result from the circumstance that the moon always presents the same side to the earth, and to account for such phenomena will be apt to puzzle the lunar astronomers. Hence, it necessarily follows that those who live on the opposite hemisphere of the moon will never see the earth nor enjoy its light. From the central parts of that hemisphere, an astronomer—who had heard of the remarkable celestial phenomenon to be seen in the other hemisphere—would have to travel more than 1700 miles before he could see the earth emerging from the horizon; and in order to behold it in its full luster, shining directly from the zenith, he would have to travel 1700 miles farther, or 3400 miles in all. We presume that there are few terrestrial astronomers who would grudge to undertake such a journey were they to behold a resplendent moon hanging in the vault of heaven in another hemisphere, which is altogether invisible in his native country. Sir J. Herschel, in order to explore the starry regions in the southern hemisphere, undertook a voyage to the Cape of Good Hope, where he remained for years, and brought home some interesting pieces of intelligence from the starry regions.

*Distance and magnitude of the Moon.*—The moon, though the nearest celestial body to the earth, is still at a considerable distance. This distance is reckoned to be, at a medium, about 237,000 miles, or about thirty times the diameter of our globe, which is determined from its horizontal parallax, or the angle formed by a line drawn from the center, and another line drawn from the surface of the earth. As the moon, however, moves in an elliptical orbit, she is sometimes more than 240,-

000 miles distant, and sometimes considerably less than 237,000. Small as this distance is, compared with that of the other planets, it would require nearly 500 days, or about sixteen months, for a steam-carriage to move over the interval which separates us from the lunar orb, although it were moving day and night at the rate of twenty miles every hour. Although the apparent size of the moon is equal to that of the sun, yet the difference of their real bulk is very great; for it would require more than sixty-three millions of globes of the size of the moon to form a globe equal in magnitude to that of the sun. The reason why the sun appears so small, when he is in reality so large a globe, is this—that he is removed ninety five millions of miles from the earth, which is nearly four hundred times farther than the moon. The diameter of the moon is 2180 miles, which is little more than the fourth part of the diameter of our globe, and consequently, in point of solidity, it is only the forty-ninth part of the bulk of the earth. Its surface, however, contains fifteen millions of

square miles, or about one-third of the habitable regions of our globe, and were it peopled as densely as England, it would contain a population amounting to four thousand two hundred millions, which is more than five times the population of the earth. The circumference of the moon is 648 miles, and, therefore, if a railroad were formed around it, its inhabitants could travel completely round their world in the course of fourteen of our days, at the rate of twenty miles an hour; and the journey could be so arranged that they might enjoy uninterrupted moonlight from the earth in one part of it, and uninterrupted sunlight during the other—an advantage which we can never enjoy in our terrestrial region.

*Telescopical appearance of the Moon.*—When the moon is viewed with a good telescope, the lunar surface presents a very interesting and diversified appearance. Mountains and plains, caverns and insulated rocks, hills and plains of almost every shape, diversify every portion of the surface of the moon. It is evident almost at first sight, that the

Fig. 35.

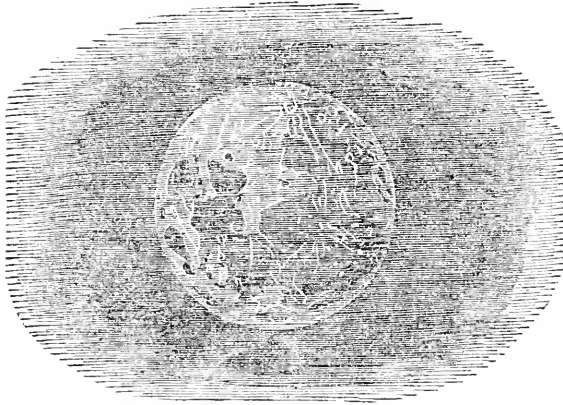

moon is diversified with inequalities of surface, and has lofty eminences and deep vales, when we view her surface with a powerful telescope, when she appears in the form of a crescent or of a half moon; for then we perceive the boundary between the dark and enlightened side—not a straight line or a regular curve, as it would be if the moon were a smooth surface—but jagged and uneven, somewhat like the edge of a coarse saw. Within the dark portion of the moon, adjacent to this boundary bright points appear, somewhat like stars, which are evidently the higher tops of the lunar mountains, enlightened by the sun before his rays can reach the valleys, just as we find that in our globe, when the sun is rising, his beams gild the mountain tops, while the plains and valleys are still in the shade. Shadows of different dimensions, too, are to be seen in various parts of the enlightened portion of the moon, indicating both elevations and depressions.

The mountainous regions of the moon are arranged in a very different form from those of the earth. There are, indeed, some mountain ranges on the lunar orb somewhat resembling our Alps, and Apennines, and Andes; but one of the distinguishing features of the moon consists in hundreds of circular ranges of mountains surrounding plains of the same shape. The following are a few of the characteristic features of the lunar surface 1. Plains of various extent and peculiarities. Some of these plains are more than one

hundred miles in diameter, or in length and breadth. They present a darker and more somber appearance to the eye than the other parts of the lunar surface, and in many instances, they contain, here and there, deep cavities. They were formerly considered as seas, or large collections of water, but there appears no evidence that seas, or any large collection of waters, exist on the surface of the moon. Beside these large plains, there are numerous circular plains of a lesser size, of all dimensions, from two or three miles to thirty miles in diameter, surrounded with a circular ridge of mountains, as with a wall or rampart. These are to be found in most regions of the moon, and they form a peculiar feature of her surface altogether different from what obtains on our globe. 2. The moon displays a great variety of mountain scenery. In the first place, there are chains of mountains, which run in a right-lined direction, not altogether unlike those which exist on our globe. The most remarkable range of this kind is that called the Apennines, which traverses a portion of the lunar disc from north-east to south-west, which may be seen to advantage about the time of half moon, and a day or two afterward. It rises with a precipitous and craggy front, from a large plain called the *mare inbrium*, extends to a great length, and, in some places, rises to the perpendicular height of four miles. This is most precipitous on the side of the plain, and gradually slopes off with its hundreds of peaks to the opposite declivity, resem-

bling in some degree our Andes and Himalayas. In the next place, there are insulated mountains, or peaks, or mountains in the shape of a sugar loaf, which rise directly from the plains, and are altogether unconnected with any ridge or group whatever. Some of these are several miles in perpendicular altitude, and their shadows thrown opposite to the sun are as distinctly seen through the telescope as the shadow of a gnomon on a sun-dial. They bear a certain resemblance to the Peak of Teneriffe, and Adam's Peak in the island of Ceylon. But in the third place, the chief features of the mountain scenery of the moon consist in those circular ranges of mountains which occupy nearly one-half of the lunar surface, and are dispersed in all directions. In some cases, they appear like a wall of sixty, one hundred, or one hundred and fifty miles in circumference, surrounding circular plains of corresponding extent. In other cases they are from five to ten or twelve miles in diameter; and in many instances there is a central mountain of a considerable elevation, which rises from the center of the circular plain. There is nothing similar to these arrangements in any part of our terrestrial system. The lunar mountains, according to Schroeter's measurements, are of all sizes, from three hundred feet to five miles in perpendicular height. 3. Another singular feature of the moon's surface consists in those numerous depressions or cavities, which appear on almost every part of her disc. These cavities are circular, and bear a certain resemblance, in shape, to an egg-cup. A high annular ridge, marked with lofty peaks and small cavities, generally encircles them, an insulated mountain frequently rises in the center, and sometimes they contain smaller cavities of the same nature as themselves. These hollows are most numerous in the southwest parts of the moon, and from this cause it is owing that that portion of the lunar surface is more brilliant than any other portion of the moon; these cavities, along with the mountainous ridges which encircle them, reflecting a greater quantity of light than any other part of the lunar regions. As to their dimensions, they are of all sizes, from three miles to fifty miles in diameter at their orifices, but they generally decrease in breadth toward the bottom. Their depth varies from about one-third of a mile to three miles and three quarters below the summits of the mountains which surround them; but in all cases the internal depth of the cavity is much lower than the general surface of the moon. Of this feature of the lunar surface we have no examples in any part of our globe; but we have reason to believe, from the variety which exists in nature, that not one world in the universe exactly resembles another in its particular arrangements.

The following figures will perhaps convey a rude idea of some of the objects on the lunar surface now described. Fig. 36 is a view of the brilliant spot called Aristarchus, which is situated in the north-east quadrant of the moon's surface, where the shadows of some of the circular cavities and also the shadows of the mountains may be perceived. Fig. 37 is the spot called Hevelius, which contains an annular cavity, and a broken elevation somewhat resembling an egg. Fig. 38 represents a cavity surrounded by a circular range of mountains, with two central mountains in the middle of the plain, in which the shadows of one side of the circular range and of the central mountains may be seen. Fig. 39 shows another magnified portion of the moon's disc, exhibiting several circular plains, cavities, and other varieties of the lunar surface.

From what we have now briefly stated, it is evident that an immense variety of picturesque and sublime scenery is presented to view on the surface of the moon, and could we conceive ourselves standing on some of her lofty peaks, her circular mountain ridges, or on the summit of her central mountain, we should behold a much

Fig. 36.

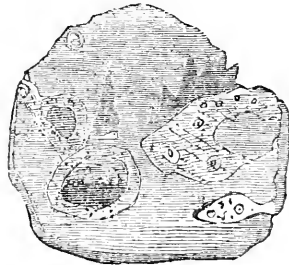

Fig. 37.

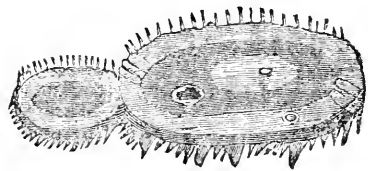

Fig. 38.

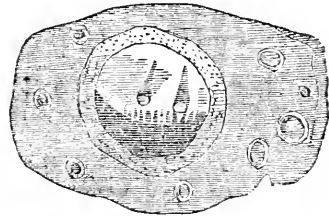
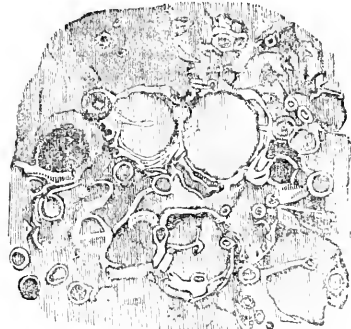

Fig. 39.



greater extent of prospect, and an assemblage of more grand and sublime objects than is presented to our view in any of our terrestrial landscapes. The best time for viewing all the varieties of scenery on the moon's surface, with a telescope, is about the period of half moon, or two or three days before or after it, at which times the shadows of the lunar mountains and cavities are longest and most distinct. At the time of full moon, many of the objects described above cannot be

perceived, as the sun then shines perpendicularly upon the moon's surface, so that the shadows of the different objects cannot be distinguished. The following additional particulars respecting the moon may be stated.

1. The length of a lunar day is equal to nearly fifteen of our days, and the length of the night the same, so that a day and night in the moon is equal to twenty-nine days and a half, or one lunar month. On the hemisphere next the earth, there is moonlight nearly all the time the sun is absent; but in the other hemisphere, in the absence of the sun, there is no light but what proceeds from the stars and planets. Were a lunarian to travel, at the rate of ten miles an hour, in a direction at right angles to the moon's axis, he might keep pace with the moon's rotation, and be enabled to live in perpetual sunshine. 2. The light of the moon has been computed to be 300,000 times less intense than that of the sun, when shining in an unclouded sky; yet its utility is considerable, and when the full moon shines in its splendor, it throws a cheerful, though mild light, over the surrounding landscape. 3. The nearer the moon is to the periods of new and full moon, the greater is her velocity in her orbit; and the nearer she is to the quadratures, the slower she moves. When the earth is in its perihelion, or nearest the sun, which happens in the winter, the periodical time of the moon is greatest; and when the earth is in its aphelion, which happens in summer, the periodical time of the moon is the least. 4. The mean inclination of the moon's orbit to that of the earth is five degrees, nine minutes. 5. The eccentricity of her orbit is 12,960 miles. 6. The moon in all probability is surrounded with an atmosphere, but it is evidently a very small one, and of extreme tenuity; and no clouds or vapors appear to exist in it. It is stated as having been distinctly perceived during the annular eclipse of May, 1836, when just before the rims of the two bodies met, the light of the sun was seen to shoot through the moon's atmosphere, mollified into twilight. Schroeter calculates its height at 5742 feet.

There can be little doubt that the moon, like the earth on which we dwell, is a world replenished with inhabitants. Matter appears to have been created chiefly in subserviency to mind; and it is highly improbable that the Creator would leave a globe containing a surface of fifteen millions of square miles altogether destitute of sensitive and intellectual beings, especially when we behold its surface diversified and adorned with such a vast assemblage of picturesque and sublime scenery, and when we consider that every department connected with our globe is peopled with sentient beings of every description. Although seas and rivers and a dense atmosphere are not to be found connected with the lunar orb, and although some of its arrangements are different from those of the earth, yet these circumstances form no valid objection to the moon being inhabited, for the Creator can in all cases adapt the inhabitant to the nature of the habitation provided for him, as he has adapted the birds for winging their flight through the air, the fishes for gliding in the waters, and man and quadrupeds for traversing the dry land.

It has frequently been a subject of inquiry, Whether the inhabitants of the moon may ever be discovered by the inhabitants of our globe? Notwithstanding the improvements that have been made on telescopes in modern times, we have no expectations that such a discovery will ever be made. Even the large telescope lately

constructed by the Earl of Rosse, however distinct and beautiful a view it may exhibit of the mountains and vales, rocks and caverns, on the lunar surface, will never be able to show us its inhabitants, although they had bodies five hundred times larger than those of the inhabitants of the earth. That telescope has seldom been used with powers exceeding eight hundred times; but although a power of two thousand times could be put upon it with distinctness, it would make the moon appear no nearer to us than one hundred and twenty miles, at which distance a living being, although a hundred feet high, could not be beheld. For, with such a power, a space on the moon's surface one hundred and eighty-three feet in diameter could only be perceived as the smallest visible point. Beside, we ought to consider that when we view objects on the surface of the moon, we do not view them in perspective, as we view objects on the surface of the earth, but only obtain a bird's eye view, as we do of objects on the surface of our globe, when viewed from a balloon suspended in the atmosphere, in which case, when we look down upon a group of human beings, we perceive only the length and breadth of their heads and shoulders.

There is a possibility, however, of tracing the operations of sensitive, or intelligent beings, in the lunar orb, although we can never expect to trace the forms or motions of its inhabitants. Were a vast number of persons in different parts of the world to devote themselves to a particular survey of the moon—were different portions of its surface allotted to different individuals as the object of their particular research—were accurate observations made, and frequently repeated, on every mountain, hill, cavity, cliff, and plain, and every change and modification in the particular spots and their localities carefully marked and represented in a series of delineations, it might lead to some certain conclusion both as to the physical constitution of the moon, and as to whether any of the observed changes proceeded from the operations of living agents. If an observer in the moon, with such a telescope as Sir William Herschel's, or that of the Earl of Rosse, had observed the city of Babylon, when in its splendor, and afterward when reduced to a desert, as it now is, he must have observed a change in the locality where that famous city once stood, indicative of the operations of intelligent, or at least, of sensitive, or living agents. And had he viewed the dense forests of America before civilized nations took possession of that country, and were he now to take a view of the eastern states of North America, in their present state of cultivation, and since the great cities of New York, Boston, and Philadelphia were reared, a striking difference between the present and the former state of that country would doubtless be perceptible. For, if an extent of only one hundred and eighty-three feet, or sixty-one yards, would be perceptible by a telescope magnifying two thousand times, much more would the extent of a large city, such as New York, be distinctly visible, as a prominent and well-defined object. Now, if changes similar, or analogous to these, could be traced on the surface of the moon, it would lead us to form some certain conclusions in relation to the operations of intelligent agents, and consequently, that such beings actually exist on the lunar surface. But such observations as those to which we allude would require not only to be specific and minute, but also to be continued for a length of years—perhaps a century or more—before any striking changes could be expected to occur.



Dr. Olbers was fully of opinion, from the observations he had made, "that the moon is inhabited by rational creatures, and that its surface is more or less covered with a vegetation not very dissimilar to that of our earth." It has formed a subject of speculation with some, whether it might be possible to correspond with the lunar inhabitants by symbolical representations. If they be mathematicians, it has been conceived that the erection of geometrical figures on some extensive plains on our globe, on a scale of vast extent, might be recognized by the inhabitants of the moon, as a signal of correspondence, and that they might erect similar figures in return. But it is highly questionable whether the design of such figures would be appreciated, or whether they would be visible to the eyes of the inhabitants. Many a look, we may conceive, will be directed to our globe by the lunar inhabitants, and much wonder will doubtless be expressed at such a large globe hanging over their heads, apparently immovable, excepting a rotation round its axis; and much speculation, will, without question, take place among them as to whether such a globe as ours be inhabited. But it does not appear to be the design of the Creator, in the meantime, that the inhabitants of our globe and those of the moon should become acquainted, or that any direct correspondence should take place between different worlds. And therefore, we must wait with patience until the scenes of a future life shall unravel the mysteries, and dispel the darkness which now hangs over the history, the population, and the transactions of other worlds. Whatever may be the peculiar circumstances of the beings that people other globes, we know that they are all under the care and superintendence of Him who is infinite in wisdom, power and intelligence; whose "kingdom ruleth over all," and whose "tender mercies are over all his works."

But, whatever opinions we may entertain respecting the inhabitants of the moon, certain it is that she forms a beautiful and noble appendage

to our globe, and her light and motions are of high utility to its inhabitants. How cheerless and uncomfortable, in many cases, would be our nights, were it not for the mild radiance which the lunar orb dispenses in such regular and agreeable vicissitude! To the mariner, while plowing his course through the stormy deep; to the plowman, "plodding his weary way;" to the peasant, pursuing his course through moors and morasses after nightfall; to the shepherd, tending his fleecy charge by night; to travelers in foreign lands; and to the missionary in pagan countries, when returning at midnight from his sacred labors; the moon, in her various stages, is always a most cheerful and welcome visitant. She throws a mild and silvery lustre over the forests, the mountains and the vales, and we behold a new picture of terrestrial objects, which is more delicately shaded, and disposed into softer lights than that which is displayed under the blaze of the meridian sun—a scene which leads the pensive mind to pleasing reflections, and to solemn contemplation. By her attractive influence, she sways the ocean, and perpetuates the regular returns of ebb and flow, by which the liquid element is preserved from putrefaction, and the inhabitants of the islands and continents from infection and disease. And, although her brightness is not the same at all seasons, and though she is sometimes absent from our nocturnal hemisphere, yet, in her absence, we enjoy, on a clear evening, a more extensive prospect of the starry regions, and of those remote spaces of creation where suns unnumbered shine, and planets and comets run their solemn rounds. Let us then be grateful to our beneficent Creator, who, in this as well as in all his other works, has displayed his infinite wisdom, and his unbounded goodness; and let us in unison with the inspired writers, praise the name of the Lord, who hath appointed "the moon to rule by night," as an evidence of his fatherly care, and of his mercy, which "endureth forever."

## CHAPTER IV.

### DESCRIPTION OF THE SUPERIOR PLANETS OF THE SOLAR SYSTEM.

#### SECTION I.

##### ON THE MOTIONS AND ASPECTS OF THE SUPERIOR PLANETS.

The planets Mercury and Venus, whose motions and phases we formerly described, are called inferior planets, because they revolve round the central luminary in orbits which are included within the orbit of the earth, and consequently nearer the sun than the earth is. The superior planets are those whose orbits are without that of the earth, and, of course, at a greater distance from the sun. The superior planets are Mars, Vesta, Juno, Ceres, Pallas, Astræa, Jupiter, Saturn, and Uranus. They are distinguished from the inferior planets in the following respects:—1. They come to our meridian at midnight, which the inferior planets never do. 2. They are sometimes seen rising in the east, when the sun is setting in the west; a circumstance which never happens to Mercury or Venus. 3. While the

inferior planets always appear to move in the neighborhood of the sun, never removing beyond forty-eight degrees of that luminary, the superior planets may be seen at all distances from the sun, and even in the opposite quarter of the heavens. 4. The superior planets never can appear to transit the sun's disc, as Mercury and Venus have been seen to do at different periods. 5. The superior planets never appear in the form of a crescent, or of a half moon, as the two inferior planets are found to do in certain parts of their orbits. They always appear with a round face, when viewed with a telescope, except Mars, which sometimes appears with a slight gibbous phase. 6. A superior planet can only be in conjunction with the sun, when the sun is between the earth and the planet; whereas an inferior planet may be in conjunction with the sun, when it is between the sun and the earth. 7. There are also certain peculiarities in reference to the direct and retrograde motions of the superior planets, and the points in which they appear

stationary, different from those of the inferior planets. All these circumstances clearly show that the path of the earth round the sun is included within the orbits of the superior planets; that we occupy a station that is never very far removed from the center of their orbits, and that we see these planets in a direction which is nearly that in which the sun's rays enlighten them.

*Apparent motions of the superior Planets as seen from the Earth.*—The superior planets are retrograde when seen in opposition to the sun, that is, they appear to move from east to west, or contrary to the order of the signs of the zodiac; and their motion appears direct, or from west to east, when in conjunction with the sun. The following diagram, fig. 39,\* will illustrate some of the motions and aspects of these planets. Let the central circle *s* represent the sun, *A B C D* the orbit of the

Fig. 39.\*

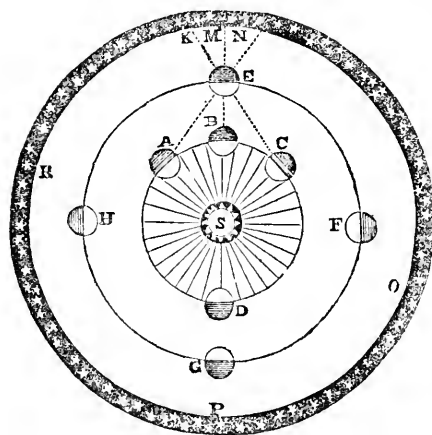

earth; *EFGH* the orbit of a superior planet, suppose that of Mars, and *KMNOPR* a portion of the starry heavens. When the earth is at *B*, and Mars at *E*, the planet, as seen from the earth at *B*, will appear in the same part of the heavens as the sun, or in conjunction with him. When the earth is at *r* and the planet at *E*, it is then said to be in opposition to the sun; for the sun is then seen in the direction *s r*, while the planet is seen in the direction *s n*. In this case, the planet is nearest to the earth, and in the case of Mars, it is only fifty millions of miles distant from us. But when the earth is at *B* and Mars at *G*, the planet is the whole diameter of the earth's orbit, or one hundred and ninety millions of miles farther distant, and consequently, at that time, two hundred and forty millions of miles from the earth. Hence it happens that this planet appears about twenty-five times larger in the one case than in the other. When farthest distant from the earth, it appears like a small star; but when nearest us, it appears nearly as large as Jupiter or Venus, but with a more ruddy aspect. These circumstances clearly prove that Mars does not move round the earth as its center of motion, as the ancients supposed, but round the sun, and that, too, in an orbit which includes the earth's orbit within it.

The cause of the direct and retrograde motions of the superior planets will likewise appear from fig. 39. Suppose the earth at *A*, and Mars at *E*, while the earth is moving through the part of its orbit *A B C*, the planet will appear to move from *x*

to *κ* among the stars, which is its direct motion through the heavens, or from west to east; so that when the earth is at *B*, the planet will appear at *m*, and when the earth is at *C*, it will appear at *κ*. But while the earth moves through *C B A* to *A*, it will appear to return to *κ*, having a retrograde motion from east to west; so that when the earth is at *B*, it will appear to be at *m*, and when the earth is at *A*, it will appear to have returned back to *κ*. When the earth is either at *A* or *C*, the planet will appear stationary for a few days. The direct motion is very slow from *x* to *κ*, because the earth has to move, during its continuance, through the large part of its orbit *A B C*; but the retrograde motion, from *κ* to *x*, is performed in much less time, because the earth, while it continues, has to move only from *C* to *A*.

We have supposed the planet at rest, in order to avoid complexity in the illustration; but the appearances will be the same, whether we conceive the planet at rest or in motion; only the time in which the direct and retrograde motions are performed will be different when we view the planet as in motion. Jupiter, Saturn, and all the other superior planets have similar direct and retrograde motions and stationary positions. They all retrograde when in opposition, and for some time before and after it; but they differ greatly as to the time of its duration. It is more rapid and extensive in the case of Mars than of the other planets which are farther distant from the sun. It may just be further stated, that the times of the conjunctions, oppositions, direct and retrograde motions, and also of the stations of the superior planets depend upon the combinations of their motions in their orbits with the motion of the earth in its orbit; and this combination causes all the apparent irregularities which appear in the motions both of the superior and inferior planets. But all the planets, if viewed from the sun, the center of their motions, will appear to move without interruption in the same direction; only moving somewhat more slowly in their Aphelion, and more swiftly in their Perihelion.\*

## SECTION II.

## ON THE PLANET MARS.

This is the first of the superior planets next to the earth. Its name, which was given by the ancients, signifies "the god of war," which appears to have been given on account of its ruddy or fiery appearance, and because the astrologers imagined it to be a promoter of war and bloodshed. It is rather unfortunate that the names of the planets, as well as of the celestial constellations, should all be derived from heathen mythology, and from the superstitious and idolatrous views of the ancients. It ill comports with the peaceable study of astronomy that a god of war should be supposed riding in his fiery chariot through the heavens, and brandishing his sword over the nations to excite them to diabolical contests. It presents a melancholy and degrading picture of human nature, that in all ages war has produced its horrid massacres and devastations among every kindred, and in every clime, and that men should have imagined that a celestial

\* The Aphelion is that point of the orbit of the earth, or of any other planet, which is farthest from the sun; and the Perihelion is that point in the orbit of a planet which is nearest to the sun. As the planets move in elliptical orbits, they must, of course, be at different distances from the sun in different parts of their orbits.—See Appendix, No. III.

deity was appointed to preside over its infernal operations, and to "urge the foes to battle." It will be to the eternal dishonor of the human character, that ever such malignant exploits were engaged in, in our terrestrial sphere. In modern times, it is an indelible disgrace to nations, who designate themselves as civilized and enlightened, that such a mode of settling disputes between states and empires should be resorted to as that of warfare. It is glaringly unchristian; it is inhuman and atrocious; it is a violation of the fundamental laws which unite the moral universe; it is accompanied with almost all the evils which can afflict humanity; it is subversive of the wealth and prosperity of nations; and it must be highly offensive to the Creator, who has so curiously constructed the human frame, and formed man "after his own image," that such an exquisite structure should be cut and slashed and destroyed by those who are partakers of the same nature. In short, it conveys an absurdity in the very idea of it; for it never can decide on which side of a disputed question justice and right are to be found; and it degrades man, who is endowed with high intellectual powers, to a level with the inferior animals—with the bear, the lion, and the hyena, that have no other mode of settling their disputes but by physical force. Scarcely anything can be more degrading and monstrous, in beings furnished with moral faculties, and endowed with reason and intelligence. But it is needless to say that the planet Mars, though somewhat more ruddy than the other planets, has no influence whatever over such barbarous and malignant exploits. It sweeps along in its course through the heavens, in unison with the other bodies which compose the solar system, in obedience to a universal law, and displays, in its motions, its Creator's power and wisdom.

The distance of this planet from the sun is one hundred and forty-five millions of miles, and the circumference of its orbit about nine hundred millions of miles. The distance of its orbit from that of the earth is fifty millions of miles; and, at the time of its opposition to the sun, it is about this distance from the earth—which is the nearest approach to the earth which any primary planet can make, the planet Venus only excepted. It accomplishes its revolution round the sun in six hundred and eighty-seven days, or about one year and ten months, which is at the rate of fifty-four thousand miles an hour—a rapidity of motion which affords a striking idea of the omnipotent energies of the Creator. But before it can return to the same relative position in regard to the sun, or, in other words, from one conjunction or opposition to another, it occupies a period of seven hundred and eighty days—that is, two years and fifty days. It is only at the period of its opposition, when it is nearest the earth, and a short time before and after it, that this planet makes its most splendid appearance, almost rivaling Jupiter in its luster; and therefore, before we can again see it with the same degree of luster, a period of two years and fifty days, at an average, must elapse. It was in this position in June, 1843; again in August, 1845; and again in October, 1847. This is the most eligible period for observing the surface of Mars through telescopes, and, likewise, for observing its direct and retrograde motions. From spots which have been observed on the surface of Mars by the telescope, it was determined that it makes a revolution round its axis in twenty-four hours and nearly forty minutes—which is only forty-four minutes longer than the diurnal rotation of the earth, and is per-

formed in the same direction, namely, from west to east. Its axis is inclined to the plane of the ecliptic at an angle of nearly sixty degrees, or about thirty degrees from the perpendicular. Of course there must be different lengths of days and nights in different regions of this planet; and, likewise, a diversity of seasons, somewhat similar to what we experience on our globe.

This planet, as to size, ranks among the smaller bodies of the solar system. Its dimensions are as follows:—Its diameter is found to be about four thousand two hundred miles—which is little more than half the diameter of our globe. Its surface contains above fifty-five millions of square miles, which is several millions more than the number of square miles on the habitable parts of the earth. Were its whole surface composed of land, and were it peopled in the same proportion as Belgium—three hundred inhabitants to a square mile—it could contain a population of sixteen thousand five hundred millions, or more than twenty times the present population of our globe; so that this planet, though comparatively a small one, may rank higher than even our world in respect to the number of sensitive and intellectual beings it may contain. This planet, like the earth and several other planets, is of a spheroidal figure, its polar diameter being about two hundred and sixty miles shorter than its equatorial.

When viewed with good telescopes, spots of various forms have been discovered on the disc of Mars. It was, however, more than fifty years after the invention of the telescope, before any discoveries were made on the surface of this planet, or any spots could be seen to determine its rotation. Cassini, an Italian astronomer, about the year 1666, was among the first who perceived several dark spots on the surface of Mars; and Dr. Hooke, in England, and Campani, at Rome, about the same time, made similar observations. It was found that all the features which the planet exhibits at any moment, gradually disappeared in twelve hours and twenty minutes, at the expiration of which time it exhibits an entirely different appearance; and, by continuing to observe its disc, the former features were seen to come successively into view—and thus was its revolution round its axis ascertained, and the period of it accurately determined. Some observers have remarked that these spots do not always appear well-defined, and that they frequently change their form; but that some of them continue always the same. It appears probable that clouds exist in the atmosphere of Mars, and that these, being occasionally interposed between the eye of the observer and the surface of the planet, may cause the changes of appearance which have been observed. It is admitted by all astronomers that an atmosphere, or body of air, of considerable density and extent, surrounds this planet; for it is found that small stars, as they approach the edge of its disc, suffer a gradual diminution in brightness, before they disappear, by the interposition of its body; and this obscurity of a star, when seen in such circumstances, must arise from its being viewed through a dense medium connected with the planet. The circumstance, therefore, of an atmosphere around Mars, combined with the fact that it has a revolution round its axis, to produce the alternate succession of day and night, forms a strong presumptive proof that this planet is an inhabited world, and destined to afford existence and happiness to numerous orders of beings.

There is an intensely white spot which has been long observed around the pole of Mars, when, emerging from darkness, it first receives the sun's

light; and this gradually diminishes in magnitude and brightness until the pole again withdraws itself from the sun; and as regularly and certainly re-appearing, when the same pole emerges from the cold and darkness of its winter. For as the axis of Mars is inclined to its ecliptic, or the plane of its orbit, one of its poles is deprived of the solar light during eleven months, or one-half of its year, in the same manner as the north pole of our globe is in darkness from the end of September to the 21st of March. Now, it has been supposed that, during this long winter of eleven months in the polar regions of Mars, these regions are covered with snow, which is the cause of the white appearance about the poles, when these poles emerge from darkness; and, after long exposure to the sun's rays, during the other eleven months, when the sun is shining upon them without interruption, these polar snows are gradually dissolved, so as to leave the naked soil of that region exposed to view.

The following are the results of Sir John Her-

schel's observations on this planet, made with a twenty feet reflecting telescope. He says that, on account of the clearness of its atmosphere, he has been enabled to observe, with perfect distinctness, the outlines of continents and oceans; that the land on its surface is distinguished by a red hue, which imparts to the planet the ruddy appearance it has when viewed by ordinary telescopes, and which its light exhibits to the naked eye. This redness he ascribes to a quality in the prevailing soil, like that which our red sandstone districts would exhibit to an observer contemplating the earth from the surface of Mars. The seas of this planet, he observes, have a greenish hue, altogether resembling the color of our own. These spots, however, are not always to be seen equally distinct, because of the varying transparency of the atmosphere; but when they are distinctly seen, they always present the same appearance. The following are some of the telescopic views which have been taken of this planet. Fig. 40 is one of the views taken by Sir J. Herschel with his

Figs. 40-43.

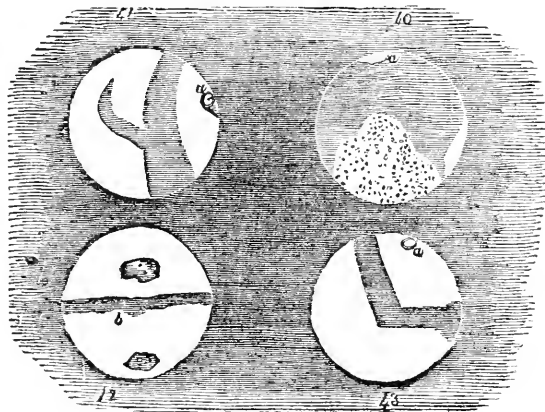

twenty feet reflector. The dark portions are considered to be water, and the white spaces land—at *a* is the white polar spot described above. Fig. 41 is one of the views given by Sir W. Herschel, which presents the appearance of a portion of a sea, with a gulf running up into the land. Fig. 42 is a view of Jupiter given by Maraldi, which he observed in 1704, and, by means of the prominence marked *b*, he determined the period of rotation. Fig. 43 is a view of Mars, which we have several times observed about the time of its opposition to the sun.

From the whole of what has been now stated respecting this planet, the following conclusions may, with a high degree of probability, be deduced—that it is environed with an atmosphere of considerable extent, in which clouds probably exist; that the dark spots are water, or seas, which reflect a much less proportion of the solar light than land, and probably cover about one-third of its surface; that a variety of seasons, somewhat similar to ours, must be experienced in this planet, but of a much longer duration; and that it bears a more striking resemblance to the world in which we dwell than any other planet of the solar system. It was owing to observations made on this planet by the famous astronomer, Tycho Brahe, and to the records of his observations having fallen into the hands of Kepler, that the three great laws of planetary motion, generally termed "Kepler's

Laws," were discovered. These laws, which we may afterward notice, lie at the foundation of modern astronomical science, and give precision to its principles.

### SECTION III.

#### ON THE NEW PLANETS.

WITHIN the limits of the present century, four new planetary bodies have been discovered, none of which was known to former astronomers. They are named Vesta, Juno, Ceres, and Pallas. They are all situate beyond the orbit of Mars, and within that of Jupiter, and present a variety of singular anomalies; but, as they are all invisible to the unassisted eye, and can never be noticed by common observers, we shall give only a brief sketch of their history, and their magnitudes and motions, so far as they are known. From the interval of nearly three hundred and fifty millions of miles which lies between the orbits of Mars and Jupiter, it was long conjectured, as highly probable, that some undiscovered planet either exists, or had existed, in some part of this vast region, so as to present something like proportion in the arrangements of the system, when compared with the distances which intervene between the orbits of Mercury, Venus, the Earth, and

**Mars.** This conjecture may be considered as having been in some degree realized by the discovery of four small bodies, situate in orbits at no great distance from each other, at an average of about a hundred millions of miles beyond the orbit of Mars.

*History of their Discovery.*—The first of these bodies which was discovered, was the planet Ceres. It was discovered at Palermo, by Piazzi, a Sicilian astronomer, in the constellation Taurus, on the 1st of January, 1801—being the first day of the present century—and within the limits of the next seven years, all the other three bodies were discovered. After being lost for some time, it was re-discovered by Dr. Olbers, of Bremen, after a series of unwearied observations—when its motions and position in the system were determined—since which time, its place in the heavens can always be ascertained. Only fifteen months elapsed, after the discovery of Ceres, when Dr. Olbers, on the 28th of March, 1802, discovered the planet Pallas. The planet Juno was discovered on the first of September, 1804, at the observatory of Lilienthal, near Bremen, by Mr. Harding, while he was endeavoring to form an atlas of all the stars near the orbits of Ceres and Pallas, with the view of making further discoveries. The planet Vesta was discovered on the 29th of March, 1807, by Dr. Olbers, who had previously discovered Pallas. He had previously conjectured that the three small celestial bodies, lately discovered, were merely the fragments of a larger planet, which had been burst asunder by some internal convulsion, and that several more might yet be discovered between the orbits of Mars and Jupiter. On this hypothesis he concluded that, as these fragments must all have diverged from the same point, they ought to have two common points of reunion, or two nodes in opposite regions of the heavens, through which all the planetary fragments must sooner or later pass. One of these nodes he found to be in the sign Virgo, and the other in the constellation of the Whale—and it was actually in the Whale that Mr. Harding discovered the planet Juno. Therefore, with the intention of discovering other fragments of the supposed planet, if any should exist, Dr. Olbers examined three times every year, all the small stars in the opposite constellations of Virgo and the Whale—and his labors were crowned with success, by the discovery of a new planet, in Virgo, to which he gave the name of Vesta.

The magnitudes of these bodies, on account of their comparatively small size, and the difficulty of measuring their apparent diameters, have not yet been accurately determined. The following is a brief summary of what has been ascertained respecting their distances, motions and magnitudes. The planet Vesta, which was last discovered, is considered as the nearest to the sun. Its distance from that luminary is reckoned to be about 225 millions of miles, and it revolves about the sun in 1325 days, or in three years, seven months and a half, moving at the rate of 44,000 miles an hour. Some have estimated its diameter at 276 miles, and if so, it will contain 229,000 square miles on its surface. But it is probable, from a variety of circumstances, that it is considerably larger in size than what is here stated. The distance of Juno from the sun is 254 millions of miles, and it accomplishes its revolution in four years and one hundred and twenty-eight days, at the rate of 41,850 miles an hour. Its diameter is estimated by certain German astronomers, at 1425 English miles. It is of a reddish color, and is free from any nebulosity, and is supposed to be

enviored with a dense atmosphere. The planet Ceres is 263 millions of miles from the sun, and finishes its revolution in four years, seven months, and ten days. Its real diameter is estimated at 1624 miles, so that its surface will contain more than eight millions of square miles; but its atmosphere is reckoned at about 675 miles in height. It is of a slight ruddy color, and appears like a star of the eighth magnitude. The planet Pallas is distant from the sun about 263 millions of miles, or about the same distance as Ceres, and completes its revolution in four years, seven months, and one-third of a month, which is within a day of the time of the revolution of Ceres. Schroeter, a German astronomer, considered this planet as the largest of the four, and he estimated its diameter to be 2099 miles, and consequently nearly the size of our moon. It presents a ruddy aspect, and is surrounded with a nebulosity, somewhat like Ceres, but not so extensive. It is distinguished from all the other planets by the very great inclination of its orbit to the plane of the ecliptic, which is no less than thirty-four degrees thirty-seven minutes.

These four planets present to our view certain singularities and anomalies, which, at first view, appear incompatible with the harmony and proportions which we might suppose originally to have characterized the arrangements of the planetary system. 1. Their orbits are in general more eccentric than those of the other planets; in other words, they move in longer and narrower ellipses. The eccentricities of the orbits of Juno and Pallas amount nearly to one-eighth part of the transverse axes of their orbits; whereas the eccentricities of the orbits of Jupiter and Uranus are only the one forty-third part, and that of the earth, one hundred and nineteenth. Hence it follows, that Pallas and Juno will sometimes be 129 millions of miles farther from the sun at one period than at another. 2. Their orbits have a much greater degree of inclination to the ecliptic than those of the other planets; that of Pallas being no less than thirty-four degrees and a half, which is twenty-seven times greater than that of Jupiter. 3. They revolve nearly at the same mean distance from the sun. The mean distance of Juno is 254,000,000; of Ceres, 262,903,000, and of Pallas, 262,901,000 of miles; while in the case of all the other planets, many millions of miles, sometimes amounting to hundreds, intervene between their orbits. 4. They perform their revolutions in nearly the same periods. The period of Juno is four years, four months and a half; of Ceres, four years, seven months and a half; and of Pallas, four years, seven months and a half; whereas the periods of the old planets differ very considerably from each other: that of Mars being less than two years; that of Jupiter, twelve years; of Saturn, nearly thirty years; and of Uranus, eighty-four years. 5. The orbits of some of these planets cross each other. This is a very singular and unaccountable circumstance in regard to planetary orbits, and cannot possibly happen in the case of the other planets, or any of their satellites. This is represented in the following diagram, fig. 44. The orbit of Vesta crosses the orbits of the other three, and therefore it is a possible circumstance that a collision might take place between Vesta and these three planets at the points of intersection *a* and *b*; and were it ever to happen, the consequences would be dreadful to both planets.

Within a very short period, a new planet has been discovered by Mr. Hencke, of Dreisen, in Prussia. It appeared like a star of the ninth mag-

nitude, in a place where, before, there was none. This discovery was made on the 8th of December, 1845. Its place on December the 14th, as found by Professor Encke, of Berlin, at six hours twenty-eight minutes, was, right ascension, 64

Fig. 44.

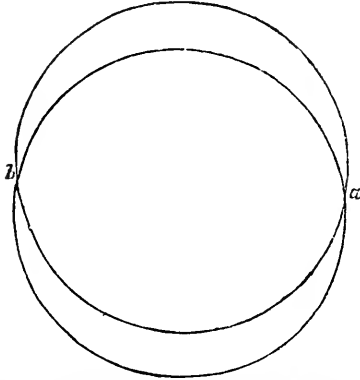

deg 4 min. 53 sec. At thirteen hours, 34 min. 55 sec., its right ascension in time was 4 hours, 16 min., 2 sec. Declination north, 12 deg. 39 min. 53 sec. At fourteen hours, 33 min. 27 sec. Right ascension in time, 4 hours 16 min. Declination north, 12 deg. 39 min. 52 sec. Its motion was retrograde, and its daily amount, as determined from the observations, 8 hours apart, was, in right ascension, 14 min. 21 sec. In declination, its motion was quite insignificant. This moving body was afterward observed in England by Messrs. South, Airy, and others; and from their observations and those of foreign astronomers, it has now been determined to be a planet belonging to the solar system, to which the name *Astræa* has been given.

From the notes of *Astræa*'s position given by Encke and Schumacher, M. Faye, a French astronomer, has calculated the elements of its orbit. They are as follows:—

	Deg.	Min.
Epoch, 1845, Dec. 14.....	71	13.6
Longitude of ascending node, .....	135	14.6
Inclination, .....	6	1.2
Semidiameter of orbit, .....	26,024	
Movement, .....	direct.	
Period of sidereal revolution, .....	4 years 2 months.	

It appears, therefore, that *Astræa* has a certain relation to the four minor planets, revolving between Mars and Jupiter, which were discovered about the beginning of the present century. This relation will appear at once when their elements are compared, as in the following statement:—

	Mean dist. from the sun.	Mean period in days.	Inclination of orbit.
Vesta, . . . . .	2.3678	1325	7° 8' 9"
Juno, . . . . .	2.6690	1592	13 4 9
Ceres, . . . . .	2.7672	1681	10 37 26
Pallas, . . . . .	2.7728	1686	34 34 55
<i>Astræa</i> , . . . . .	2.6024	1521	6 1 2

In the element of distance, that of the earth from the sun is taken as a unit. The distance of *Astræa* from the sun is to that of the earth as 2.6924 to 1.000, or in round numbers as 26 to 10. It follows that *Astræa* revolves round the central luminary at the distance of 247,000,000 miles.

In its distance and period of revolution, *Astræa* agrees most nearly with Juno, in inclination with Vesta.

The discovery of this planet affords a strong corroboration of the hypothesis which supposes that the four new planets formerly discovered, originated from the disruption of a large planet which formerly moved between Mars and Jupiter. Such a catastrophe is involved in a great mystery; and yet, without supposing it to have taken place, we can scarcely account for the peculiarities of these planets, which form anomalies in the solar system. It is not improbable that other bodies, originating from the same source, may yet be discovered.

Such anomalies and singularities, in the case of these lately discovered bodies—so very different from the arrangement of the other planets—have opened a field for speculation and inquiry. It has been supposed, on somewhat plausible grounds, that these planets are only the fragments of a larger planet which had been burst asunder by some immense eruptive force proceeding from its interior parts. This hypothesis accounts in a great measure for the anomalies and apparent irregularities to which we have alluded, particularly for the intersection of their orbits, and for the fact, that the planets are not round, as is indicated by the instantaneous diminution of their light, when they present their angular faces. It has also been supposed that the smaller fragments that may have escaped at the time of the disruption, may account for some of the meteoric stones which at different times have fallen from the higher regions upon our globe.

Whether we consider the present peculiarities, positions and motions of these planets, as according with the state in which they were originally created, or whether we view them as the effects of some tremendous shock or disruption, there appears to be something sublimely mysterious and worthy of attention in the physical—not to say moral—arrangements of the Almighty, in the state in which these bodies are now found. If they were originally arranged in the position and order in which they now appear, they present an anomaly, a want of proportion and harmony, to whatever appears elsewhere throughout the whole range of the system. And, if their present phenomena be the effects of some dreadful concussion, the fate of the beings that inhabited the original planet must have been involved in the awful catastrophe. We need not be much surprised, although such an event should have taken place, nor should we consider it as inconsistent with what we know of the physical and moral government of the Almighty. For an event somewhat analogous happened to our own globe, at that period when "the cataracts of heaven were opened, and the fountains of the great deep were broken up," when a flood of waters ensued which covered the tops of the loftiest mountains, transformed the earth into a boundless ocean, and buried the myriads of its population in a watery grave. And we profess to believe that a period is approaching when the great globe we inhabit shall undergo a tremendous change, and its elementary parts be dissolved, when the aerial "heavens shall pass away with a great noise, and the elements shall melt with fervent heat, the earth also, and the works that are therein shall be burned up."

All the parts of the material system are liable to change; and we have no reason to conclude, that, throughout the future periods of duration the earth is the only globe in the universe whose present constitution and aspect shall undergo an

important change. As it is probable that the work of creation is incessantly going forward throughout different regions of immensity, so it is highly probable that numerous changes and renovations are taking place in those departments of creation which have long existed, in order to present new scenes and new manifestations of the perfections of the Creator to the view of the intelligent universe. For the whole system of creation appears to be in incessant motion; there is not an orb in the firmament, among all the millions it contains—whether great or small—but is in rapid and perpetual motion through the vast spaces of infinitude, and, in the course of ages, these movements, conducted by certain laws, under the direction and superintendency of the Supreme, may produce changes and revolutions which will add to the grandeur of the material universe, and excite the admiration of the intelligent system. He only is immutable who existed from eternity past, who gave birth to all created beings, whose presence fills the immensity of space, and of whose years there shall be no end. And throughout all the regions of space, so far as the material creation extends, his moral government is exercised, in a thousand different modes, corresponding to the rectitude, the wisdom and the benevolence of his character, and the condition of the intellectual beings he has formed. For wherever power, wisdom, and intelligence are displayed, there also must all the other perfections of the Almighty be in incessant operation; and hence we are informed, that “he doth according to his will in the army of heaven” as well as among ‘the inhabitants of the earth.’”

#### SECTION IV.

##### ON THE PLANET JUPITER.

This planet is the largest body connected with the planetary system, the sun only excepted. It is situate about 232 millions of miles beyond the orbit of Pallas, 350 millions beyond the orbit of Mars, and 495 millions from the sun. When nearest the earth, it is 400 millions of miles distant from us, and when in the remotest part of its orbit from the earth, it is 590 millions of miles distant. Notwithstanding this immense distance, owing to its great magnitude, it appears the most brilliant star in the heavens next to the planet Venus. Its revolution round the sun is accomplished in four thousand three hundred and thirty-two days and a half, or about 11 years, 10 months, and 17 days, during which it performs a circuit of more than three thousand millions of miles, at the rate of more than twenty-nine thousand miles an hour. Its diameter is no less than eighty-nine thousand miles; its circumference two hundred and seventy-nine thousand miles, and its surface twenty-four thousand eight hundred and eighty millions of square miles, which is more than one hundred and twenty-six times the area of our globe. But as globes are to each other as the cubes of their diameters, and the cube of Jupiter's diameter is 704,969,000,000,000 miles, and the cube of the earth's diameter is 498,677,257,000; divide the cube of Jupiter's diameter by that of the earth, and the quotient will be 1:113; showing that Jupiter, as a solid globe, is one thousand four hundred and thirteen times larger than the earth. This huge planet moves round its axis in the space of nine hours and nearly fifty-six minutes; which is a more rapid rotation than that of any of the other planets. Its equatorial parts will move with

a velocity of twenty-eight thousand miles an hour, which is twenty-seven times more rapid than the earth's rotation, by which the inhabitants at the equator are carried along at the rate of 1037 miles an hour. The rotation of this planet was first determined about the year 1665, by Cassini, by observing the gradual motion and revolution of a spot which appeared to move from one side to another of its disc, and returned again to the same point in nine hours and fifty-six minutes, and as the spot was evidently connected with the body of the planet, the conclusion was evident, that the planet itself turned round its axis. Hence we learn, that there is an alternate succession of day and night on Jupiter, analogous to that which we experience on the earth; but the days and nights are much shorter than ours, and the sun and the moons which belong to this planet, together with the whole frame of the heavens, will appear to move around it with a much greater rapidity than what appears from our terrestrial habitation.

The axis of this planet being nearly perpendicular to the plane of its orbit, it cannot have the same variety of seasons as the earth and Mars. Its inclination, however, is three degrees, five minutes, which will produce a slight change of seasons both in the polar and equatorial regions. Had the axis been as much inclined to the orbit as in the case of the earth, the polar regions would have been deprived of the light of the sun for nearly six years without interruption. And although the light and heat of these regions cannot be so great as in other parts of the planet, yet there are many ways unknown to us, by which the All-wise and Beneficent Creator may render every region of this globe a comfortable habitation for both sensitive and intelligent beings.

The apparent motion of this planet, like that of Mars, formerly explained, is sometimes direct, sometimes retrograde, and sometimes stationary. Its retrograde motion commences or finishes when it is at a distance from the sun, which varies from  $113\frac{1}{2}$  to  $116\frac{1}{2}$  degrees. The arc which it describes in this case varies from 9 degrees, 59 minutes, to 9 degrees, 51 minutes, and its period of duration from 116 days, 18 hours, to 122 days, 12 hours. Its apparent motion through the signs of the zodiac is, at an average, at the rate of a little more than thirty degrees in a year. It is at present (April, 1846), near the beginning of the sign Gemini, and will be in opposition to the sun on the 3d of December, about which period it rises near the time of sunset, in a direction nearly north-east, and will be seen shining in all its splendor, in a clear evening, until five or six o'clock the next morning. During the following years, it will be somewhat more than a month later, every year, before it arrive at its opposition; but it will be a conspicuous object in the heavens, during the winter evenings, for several successive years; and as it is the most brilliant planet in the heavens—with the exception of Venus—it is easily distinguishable from all the surrounding stars by its superior luster.

This planet, when viewed through a good telescope, presents a very splendid and interesting appearance, especially when its moons are arranged, two on each side, at nearly equal distances from the planet and from each other. When a magnifying power of above a hundred times is used, its surface appears much larger than the full moon does to the naked eye.\* The most striking appearance on the surface of this planet is a series

\* Those who are not accustomed to view the heavenly bodies through telescopes, are apt to imagine that they are not nearly so much magnified by the instrument as they re-act-

of darkish stripes, which run across its disc parallel to its equator, which are generally denominated its belts. They were first discovered by Fontana, and two other Neapolitans, about twenty-five years after the invention of the telescope. They were afterward more particularly described by Cassini, who was enabled to view them with more powerful telescopes. Their number is variable—sometimes eight have been seen at one time, and sometimes only one or two have been distinctly visible. Their general appearance for several years past, as viewed with telescopes magnifying from one hundred to one hundred and eighty times, is as follows:—two dark belts, one on each side of the planet's equator, and two fainter ones, one at each pole, somewhat broader than the equatorial belts. Sir James South states, that when he was making observations with his twenty-foot achromatic telescopes, with powers of 252 and 346, he perceived Jupiter "literally covered with belts." These belts, though generally parallel to each other, are not always so—for a portion of a belt has been seen in an oblique position to the rest. At certain times the belts have continued without sensible variation for six or eight months, and, according to some observers a new belt has been formed in the course of a few hours.

It has been a subject of much speculation and conjecture among astronomers, as to the views we should entertain respecting the nature of these belts, and the causes which operate in producing the changes which occasionally take place among them. Whatever opinion we may form on this point, it is pretty evident that the dark stripes or belts are the real body of the planet, and the bright spaces between them are either clouds in its atmosphere, or circular zones, liable to variations, which surround the planet at a certain distance from its body. Some have insinuated that the changes among these belts are owing to great physical convulsions occasionally taking place on the surface of Jupiter—an opinion altogether improbable. Others suppose that the bright streaks are the external surface of masses of clouds disposed in rows, and that such a disposition of clouds might be produced by prevailing winds blowing in a direction parallel to the equator of the planet. They have been compared to our trade-winds, which are considered as the necessary effect of the earth's diurnal rotation, combined with the influences of the solar heat upon the tropical belt of the earth; and that the rapid diurnal motion of Jupiter will cause the trade-winds in that planet to have a permanence, force and range, which would produce a distribution and ar-

ly are. With a power of one hundred times, most persons would imagine that Jupiter appeared much less than the moon to the naked eye; and yet it may be proved that such a power presents this planet to the eye with a diameter of about twice that of the apparent size of the moon. The mean apparent diameter of Jupiter is thirty-eight seconds, which, being multiplied by one hundred, the magnifying power, produces three thousand eight hundred seconds which is equal to sixty-three and one-third minutes. Now, the mean apparent diameter of the moon is thirty-one minutes, twenty-six seconds, the double of which is sixty-two minutes, fifty-two seconds, which is less than the apparent size of Jupiter when magnified one hundred times. But, when in opposition, Jupiter's apparent diameter is forty-seven and a half seconds, and consequently, at such a period, this planet will appear still larger. In order to produce full conviction of the accuracy of the above statements, an observer should view Jupiter, when in the immediate vicinity of the moon, and, looking with one eye through the telescope, and with the other at the moon, endeavor to make the image of Jupiter in the telescope to coincide with the moon, and he will then clearly perceive the proportion of their apparent magnitudes. From what has been now stated, it appears that a magnifying power of fifty times will make the disc of Jupiter appear as large as the moon to the naked eye.

agement of the clouds floating in its atmosphere, such as we observe in the appearance of its belts.

This is an opinion which very generally prevails among astronomers; but we do not think that it will fully account for the phenomena of the belts, or that it is consistent with the idea of a habitable world. For if the trade-winds in Jupiter were increased, in velocity and force, twenty-seven times greater than our trade-winds—which is admitted by those who hold this opinion—then their violence would be such as to drive everything before them along the surface of the planet, and there would be no possibility of living beings moving in opposition to such rapid currents. It is reckoned that, in a high gale, the wind moves at the rate of about thirty-eight miles an hour—multiply this number by twenty-seven, and the product, 1026, will give the velocity of a gale in Jupiter, in the same time. Now, it has been found, that a West India hurricane, blowing at the rate of a hundred miles an hour, has blown heavy cannon out of a battery, torn up trees by the roots, and carried huts, sheds, and human beings to a considerable distance through the air. What, then, would be the force of a gale moving at the rate of a thousand miles an hour? And, much more, what would be the force of a hurricane in Jupiter, moving at the rate of two thousand seven hundred miles an hour? On such a globe as ours, it would overturn and demolish everything upon its surface, so that our strongest and most stately buildings could not possibly resist its force. Such a state of things appears altogether inconsistent with the idea of a comfortable habitation either for sensitive or intellectual beings. It is much more consistent with the imperfection of our knowledge, at once to acknowledge our ignorance, and to wait for future discoveries on this subject, than to broach opinions which lead to such consequences.

The following figures represent different views of the belts of Jupiter. Fig. 45 represents one of the views taken by Cassini, in which about eight or nine belts appear, some of them somewhat broken and irregular. Fig. 46 represents another view, in which there appears an oblique belt forming a connection with two adjacent belts, as if it were a fluid running from the one into the other. Some have attempted to trace a resemblance in the changes of the belts and spots to what would appear upon the disc of the earth, viewed at such a distance as would bring it to the size of Jupiter. It is supposed that the great ocean, which environs our globe, would resemble the principal belt of Jupiter; the Mediterranean, one of the broken belts; the Caspian Sea, a large spot; some of our largest islands, the bright spots seen in the belts, as in fig. 45; and the clouds stretched round the equator of the earth, the changeable belts. But such views are more fanciful than accordant with the observed phenomena of this planet, and we must wait for further discoveries before we come to any decisive conclusions on this subject. Perhaps the Earl of Rosse's great telescope, which is now in use for celestial observations, may be the means of throwing some further light on this subject, and enable us to form more correct views of the belts, spots, and other phenomena of this planet. It has already resolved certain nebulae into stars, which were formerly supposed to be unresolvable. Fig. 47 represents a telescopic view of Jupiter and his four satellites, when two of them happen to be on each side of his disc. The belts, as represented in this figure, are nearly similar to what they have appeared for several years past.



We may just mention the following additional particulars respecting this planet:—Notwithstanding the brilliancy with which it appears in our nocturnal sky, its light, derived from the sun, is 27 times less than what falls upon the earth; and the diameter of the sun, as seen from Jupiter, is only 6 minutes, 9 seconds, or about one-fifth of the diameter the sun appears to us. The figure of this planet is that of an oblate spheroid—the equatorial being more than six thousand miles larger than the polar diameter. Its density, compared with that of water, is as  $1 \frac{1}{24}$  to 1—in other words, it is somewhat denser than water. Although it is one thousand four hundred times larger than the earth in bulk, yet it would weigh only three hundred and twelve globes of the same size and density as our globe. Its mass, as compared with that of the sun, is as 1 to 169,709. A body weighing one pound at the equatorial surface of the earth, would, if removed to the surface

of Jupiter, weigh 2 pounds, 4 ounces, 8 drams. The eccentricity of its orbit, in miles, is 23,810,000, and the inclination of its orbit to the ecliptic is 1 degree 19 minutes. In the firmament of Jupiter, no planets will be visible to such eyes as ours, excepting Saturn and Uranus. An observer, placed on this planet, would have no suspicion that such a globe as our earth had an existence in the universe—all its fancied splendors and its proud inhabitants are as much unnoticed and unknown as the smallest animalculæ in a drop of water to the unassisted eye. To his satellites, Jupiter will appear as a large and resplendent moon in their firmament, filling a considerable portion of the sky; from the surface of the first satellite it will appear above a thousand times larger than the moon does to us, and will, in succession, present to it all the diversified phases of the moon—a crescent, a gibbous phase, a half-moon, and a full enlightened hemisphere.

Figs. 45, 46, 47.

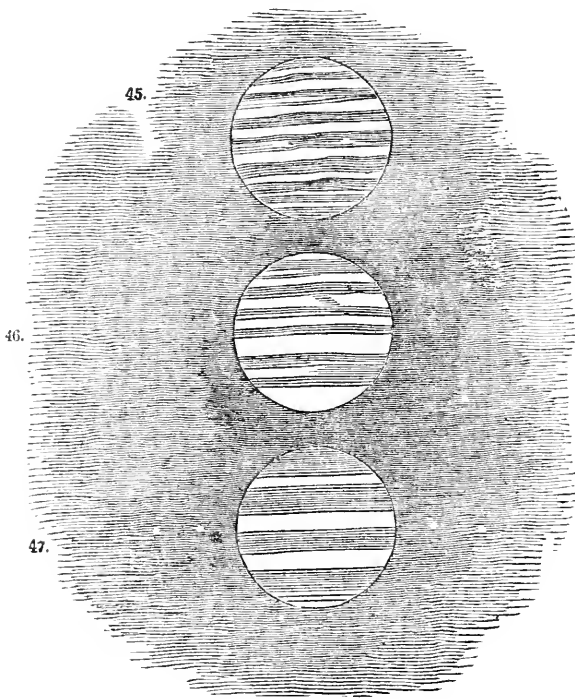

## SECTION V.

## ON THE SATELLITES OF JUPITER.

THE planet is accompanied by four satellites, or moons, which revolve around it in different periods of time. The discovery of these revolving bodies was among the first enterprises accomplished after the invention of the telescope; they were first discovered by Galileo, an Italian astronomer, in the beginning of the year 1610. In his book, entitled "Sidereus Nuncius," he gives us a particular account of their discovery, and the numerous observations he made on their motions and relative positions, accompanied with sixty-four figures of their various aspects at different times. On the 7th of January, 1610, in the evening, while observing the stars with his newly-invented telescope, he perceived Jupiter

making his appearance, and, applying his instrument to that planet, he perceived three small bright stars very near it, two on the east side and one on the west. These he took to be fixed stars at that time; but, happening the next night to view them again, he saw them all three on the west side of Jupiter; which made him greatly wonder how this could be, for it was an event quite inconsistent with the theory of the planets and fixed stars. On the tenth night he saw but two, and both on the east of Jupiter; on the eleventh also he saw but two, and both on the same side; but one of these was twice as large as the other—and, hence, he was sure they were not the same he saw the night before. On the thirteenth night, viewing them again, he saw four of these small stars, three on the west side of Jupiter, and one on the east side, all nearly in a straight

line. On the fifteenth, he beheld all the four on the west side of the planet, nearly in a straight line, and at equal intervals from Jupiter and from each other. These were all he could ever discover; and, by constantly observing their situation and changes, found that they were not fixed stars, but moons, or secondary planets, revolving about Jupiter in the same manner as the primary planets revolve about the sun. The telescope with which these observations were made magnified about thirty-three times.

These satellites form a system of revolving bodies, somewhat similar to the great system of the sun and primary planets. As the sun is the center of the primary planets, so Jupiter is the immediate central body around which the satellites revolve; but while these revolutions are going forward, the satellites are at the same time carried along with Jupiter in his course round the sun. The satellites are governed by the same laws as the primary planets; they describe equal areas in equal times; and have the squares of their periodical times proportioned to the cubes of their mean distances from the planet. They revolve from west to east, in the same direction as the moon and the primary planets—and in planes very nearly, though not exactly, coincident with the equator of the planet, or parallel to its belts. Accordingly, we see their orbits projected very nearly into straight lines, in which they appear to oscillate to and fro, sometimes passing before Jupiter, and casting shadows on his disc, and sometimes disappearing behind his body, or being eclipsed by his shadow at a distance from it. It has been established, from observation, that 247 revolutions of the first satellite, 123 revolutions of the second satellite, and 61 of the third satellite, are performed exactly in the same number of days. It has been found, by La Place, that “the epoch (or mean longitude) of the first satellite, minus three times that of the second, plus two times that of the third, is exactly equal to a semi-circle, or 180 degrees.” From this it follows, that the first three satellites of Jupiter can never be eclipsed at the same time; for, if this were possible, the longitude of three satellites would be equal at the time of their eclipse, which is impossible.

These satellites suffer numerous eclipses in their revolutions round Jupiter. The first three suffer an eclipse every time they are in opposition to the sun. The first is in opposition every forty-two and a half hours, and consequently suffers about eighteen eclipses every month. The second and third likewise suffer a variety of eclipses every month; but the fourth satellite frequently passes its opposition without being involved in the shadow of Jupiter, as its orbit has a greater degree of inclination to the orbit of Jupiter, than those of the other satellites. During the year 1845, there happened 174 visible eclipses of the first satellite, 88 of the second, and 45 of the third—beside those which are invisible on account of Jupiter's nearness to the sun. Whereas the fourth satellite did not suffer a single eclipse during the year 1846. These satellites may be seen with a telescope magnifying about twenty-five or thirty times; but, in order to see their eclipses to advantage, the telescope should be furnished with powers of 100 or 200 times. The circumstances to be chiefly observed, in reference to the satellites, are, their eclipses—that is, their entering into the shadow of Jupiter, when they suddenly disappear, or their emersion from it; their occultations or disappearance behind the body of the planet; their transits or passage across

its disc; and the transits of their shadows across the face of Jupiter, which appear like dark spots on a bright ground—all which phenomena may be perceived by means of powerful telescopes. When they pass across the disc of Jupiter, and project a shadow on its surface, this produces a solar eclipse to all those places over which the shadow passes.

It has been concluded, from observations made by Sir W. Herschel and others, that the satellites of Jupiter always turn the same face to the planet, and make one rotation on their axis during one revolution round the planet—which corresponds with what we find in the case of our moon, which, as formerly noticed, always turns the same hemisphere to the earth. The following table shows the magnitudes of these bodies, their times of revolution, their distances from Jupiter in miles, and the duration of their eclipses:—

	Diameter in Miles.	Dist. from Jupiter.	Times of Revolution.	Duration of Eclipse.
1st satellite,	2,508	260,000	1d. 18h. 28m.	2 hours.
2d	2,068	420,000	3 13 14½	3
3d	3,377	670,000	7 3 43	3½
4th	2,890	1,120,000	16 16 32	5

The fourth satellite is about three times the bulk of our moon, and all the satellites taken together are equal to nearly thirteen of our moons. The number of square miles on the surfaces of all the satellites is above ninety-five millions. Fig. 48 shows the orbits of the four satellites, though not in the exact proportion of their distances from Jupiter—the fourth satellite being nearly double the

Fig. 48.

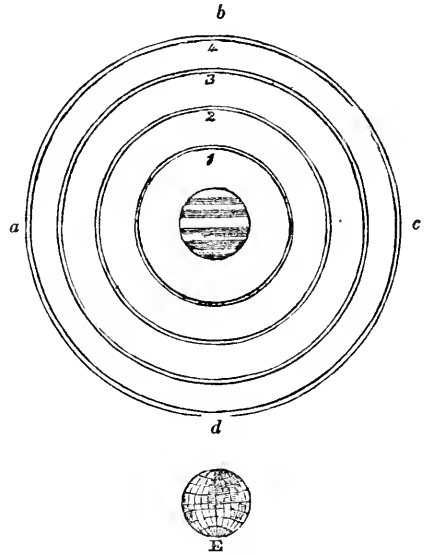

distance of the third. When a satellite moves through the part of its orbit *abc*, which is farthest distant from the earth—which is supposed to be placed in the direction *E*—it appears to move from west to east; but when it moves through the other portion of its orbit, *cda*, it appears to move from east to west. But, as our eye is nearly on a level with the plane of the orbits of these satellites, their motions appear to be performed nearly in straight lines. Though their enlightened sides are almost constantly turned toward the earth, yet they present all the varied phases of

the moon to Jupiter himself—sometimes appearing as crescents, sometimes as half moons, and sometimes shining with full enlightened hemispheres.

The eclipses of these satellites have been found of great utility in determining the longitude of places on the surface of our globe, in a manner much more accurate and easy than was known prior to their discovery. They also led to the discovery of a sublime and unexpected fact, namely, the motion of light, and the rate at which it is propagated through the regions of space. It was found that a difference of sixteen and a half minutes existed between the times when the eclipses were seen when Jupiter was nearest the earth, and when he was farthest distant, and it was concluded that light requires this space of time to fly across the earth's orbit, which is one hundred and ninety millions of miles in diameter, and, consequently, that light moves with a velocity of about one hundred and ninety-two thousand miles every second. This conclusion has been fully confirmed by Dr. Bradley's discovery of the aberration of the light of the fixed stars.

The four moons, which accompany this planet, must exhibit many curious and sublime phenomena to its inhabitants, as they perform their nocturnal courses through their firmament. Sometimes they will be seen eclipsing the sun, and, at other times, the stars, and sometimes eclipsing each other. Sometimes two, three, and even all the four will be seen shining in the heavens in one bright assemblage—one, perhaps, in the form of a crescent; one with a gibbous phase; one like a half moon; and the other with a full enlightened hemisphere; one moving comparatively slow, and another rushing rapidly through the sky, and leaving all the others behind it; one under a total eclipse, another entering into it, and a third emerging from it. These, and many other celestial phenomena, must be highly interesting and gratifying to the astronomers and all others in that far distant world. The celestial scenes exhibited from the satellites themselves will be no less interesting and sublime. From the surface of the first satellite, the globe of Jupiter will appear like an immense body in the firmament, above a thousand times the size that the moon appears to us, and filling a large portion of the sky; and it will exhibit, in the course of twenty-one hours, a crescent, a half moon, a gibbous phase, and a full enlightened hemisphere, with all the variations of the belts which diversify its surface. Beside, the appearances of the other three moons in its firmament will be highly interesting. At certain times, one of these moons will come so near the first satellite as to appear three times larger than the moon does to us, and, at other times, it will appear sixteen times smaller than in its former position; and a variety of other phenomena will be presented, which it would be too tedious to describe—all which will present to view objects of overpowering grandeur, far superior to what we behold in our nocturnal sky.

On the whole, the planet Jupiter, as accompanied with his satellites, presents to our view an object of surpassing grandeur and sublimity, when we contemplate the vast magnitude of this magnificent globe, and the velocity with which it flies through the regions of space. Let us conceive, if we are able, a globe, fourteen hundred times the size of our world, with a surface capable of containing a number of inhabitants, eight thousand times greater than the present population of our globe; let us conceive such a globe revolving round its axis at the rate of four hun-

dred and sixty miles in a minute, and flying through the regions of the heavens at the rate of nearly thirty thousand miles every hour, carrying along with it four revolving worlds in its swift career, and continuing this rapid course, without intermission; from one century to another, for thousands of years—and we behold a scene, calculated to fill every reflecting mind with admiration and astonishment. While contemplating such a scene, can we forbear raising our thoughts to that Almighty Being, who at first formed this mighty globe, and launched it from his powerful arm, and whose incessant energy sustains it in its swift career from age to age? Here we behold a demonstrative proof that "power belongeth unto God;" that "his greatness is unsearchable;" that "all nations before him are as nothing;" that there is none like unto Jehovah, nor any works like unto his works; that He "doth great things, and unsearchable," and "marvellous things without number." And here we have palpable evidence to confirm our belief that there can be nothing beyond the power of Jehovah to accomplish, and that we may rest secure that all the promises and predictions of his word shall, in due time, be fully accomplished, to the eternal happiness of all those who put their trust in Him: "For the Lord God omnipotent reigneth, his kingdom ruleth over all;" and his faithfulness is established "in the very heavens."

## SECTION VI.

### ON THE PLANET SATURN.

Thus planet is situate at nearly double the distance from the sun as the planet Jupiter—an immense interval of 410 millions of miles intervening between the orbits of these planets, although next to each other in the order of the system. Its distance from the sun has been estimated at 906 millions of miles; when nearest to the earth, it is 811 millions of miles distant from us; and, when most remote, it is distant above a thousand millions of miles. It takes nearly thirty years to perform its revolution round the sun—during which period it moves round a circumference of nearly five thousand seven hundred millions of miles, at the rate of twenty two thousand miles every hour. Its period of rotation was for a long time, unknown; but Sir W. Herschel, from observing the motion of some spots on its surface, at length ascertained that it turned round its axis in the space of ten hours, sixteen minutes, and nineteen seconds.

When viewed by the naked eye, this planet presents the appearance of a nebulous star, of a dull leaden color, which would lead one, at first sight, to imagine that it could present no very interesting appearance, even through a telescope; and, as its motion is slow, it is hardly distinguishable from a fixed star. Its motion being slow compared with that of most of the other planets—if it be once recognized in the heavens, by any observer, near any large star, it will be found, from year to year, making only a slow progress to the eastward from that point. Its apparent motion in that direction, in the course of a year, is little more than twelve degrees, or less than the moon moves in twenty-four hours. Hence, if we perceive this planet in any particular point of the heavens this year, about the same time next year it will appear only about twelve degrees farther to the east. In the year 1846, Saturn

might be seen rising on the 5th of July, about 10 o'clock in the evening, in north latitude 52 degrees, near the south-eastern part of the sky; and in 1847, about twelve days later, or about the 17th of July, he might be seen rising at the same hour, nearly in the same point of the horizon: thus the time of his appearance in the evening, from year to year, may be readily traced by any common observer.

Notwithstanding the dull appearance of this planet to the naked eye, when viewed through a powerful telescope, it presents a more singular and magnificent appearance than any other body connected with the solar system; and were it as near us as Mars, or even as Jupiter, it would present a splendid aspect even to the naked eye. The ancients, who first traced the motion of this planet, could form no idea of the grandeur of Saturn, and of the system with which it is connected; and their astrologers, on account of his pale, leaden hue, accounted him as a cheerless, unfortunate planet, and as shedding a malign influence upon the inhabitants of the earth. But after ages of darkness and superstition had rolled away, the telescope, which has unfolded to us the wonders of the heavens, was invented, and, by the help of this noble instrument, a system of revolving bodies was discovered around this planet, and a piece of celestial mechanism disclosed to view, more wonderful and magnificent than any other object within the limits of our system—the existence of which we could never previously have anticipated.

In magnitude, this planet nearly approximates to the size of Jupiter. Its diameter is estimated at seventy-nine thousand miles; its surface contains nineteen thousand six hundred millions of square miles; and its solid contents amount to two hundred and sixty-one billions, three hundred thousand millions of cubical miles. It is, consequently, nearly a thousand times larger than our globe. With powerful telescopes, four or five belts have been discovered on its surface, which are broader and less strongly marked than those of Jupiter, and are not subject to the variations which appear in Jupiter's belts—and therefore it is probable that they form permanent portions of the globe of Saturn, indicating that there is a diversity of surface on this planet; but whether land and water, or any other substance, is to us unknown. Its figure, like that of Jupiter, is a spheroid—the proportion of the polar and equatorial diameters being nearly as eleven to twelve; consequently the equatorial diameter is 6700 miles longer than the polar. The quantity of light it receives from the sun is only the one-ninth part of what we receive; but this portion of light is equal in effect to the light which would be reflected from a thousand full moons of the size of that which is connected with our world. The density of this planet is less than that of any other planet in the system. It has been calculated, on physical principles, that a ball of cork equal in size to Saturn would nearly counterpoise it, that is, would be nearly of the same weight; so that its specific gravity is less than half the weight of water. Notwithstanding, it is possible that the density of the materials on its surface may be as great as those substances which form the upper crust of our globe; and its density, instead of increasing toward the center, as is the case with the earth, may gradually decrease from its surface to its central parts, so that the materials near the center may be as light as air.

*The satellites of Saturn.*—This planet is accom-

panied with a more numerous train of attendants than any of the other planets. No fewer than seven large moons have been discovered moving around this mighty orb to diffuse light over its surface in the absence of the sun, and to diversify the scenery of its firmament. It was nearly half a century after the invention of the telescope, before any of these satellites were discovered. The first of these bodies which was discovered was that which is the sixth in the order of distances from Saturn. It was discovered on the 25th of March, 1655, by Huygens, a celebrated Dutch astronomer. In his work, entitled "Systema Saturnium," published in 1659, he gives us an account of sixty observations—each accompanied with a figure—which he made on the various positions of this satellite in respect to Saturn; in order to determine that it was a revolving body which performed a circuit around Saturn as a center. These observations were made with a common refracting telescope, twelve feet long, which magnified about sixty-eight times, but had not power nor light sufficient to show the rest of the satellites. It was not until the year 1671, that any other satellite was discovered: in that year Cassini, a French astronomer, discovered the seventh satellite, or the most distant from Saturn, which is next in brightness to the sixth; and in 1672, the same observer discovered the fifth satellite. Fourteen years afterward, namely in 1686, he discovered the third and fourth; and in making these observations he used telescopes of more than a hundred feet in length: though he tells us that afterward he could see all the five satellites with a telescope only thirty-four feet long, which could bear a magnifying power of only about one hundred and twenty times.\* No other satellites were discovered until more than a century afterward; when Sir W. Herschel erected at Slough, near Windsor, his large forty feet reflecting telescope. On the first day this telescope was fit for observation, namely on the 28th of August, 1789, the second satellite was discovered; and soon after, the same unwearied observer discovered the first, by means of the same instrument. These satellites cannot all be seen but by means of powerful instruments. The sixth and seventh, or the two outermost, may be perceived by telescopes magnifying from eighty to one hundred times; but the two innermost, discovered by Herschel, are the most difficult objects to be perceived throughout the whole range of the solar system, and have seldom or never been seen with a less instrument than a twenty feet reflector, and eighteen inches aperture. It has been remarked, that the seventh satellite, or the most distant from Saturn, is sometimes not visible in the eastern part of its orbit, and that it appears to grow dimmer and dimmer as it recedes from its primary. This has been accounted for by supposing that it is sometimes covered with spots, and at other times free of them, or, if the spots be permanent, that it has a rotation round its own axis. The following are the periods of the sidereal revolutions of these satellites, and their distance from Saturn in miles. The first satellite, or that nearest to Saturn, performs its revolution in twenty-two hours and a half, at the distance of 120,000 miles from the center of the

\* The long telescopes here alluded to—which were very difficult to manage, and required great dexterity and address in using them—are now entirely superseded by the invention of achromatic and reflecting telescopes, which will bear a high power, with a comparatively short length of tube; an achromatic telescope, 5 feet long, may carry a magnifying power superior to that of a common refracting telescope a hundred feet in length.

planet, and only 18,000 miles from the edge of the ring. Of course, this satellite will move round the visible hemisphere of Saturn's firmament in little more than eleven hours. The second satellite revolves round the planet in one day and about nine hours, at the distance of 150,000 miles. The third satellite performs its revolution in one day twenty-one hours and a quarter, at the distance of 190,000 miles. These three satellites are all much nearer to Saturn than our moon is to the earth; and as they are undoubtedly larger than our moon, they must present a large and splendid appearance to the inhabitants of Saturn. The fourth satellite completes its circuit in two days, seventeen hours and three quarters, at the distance of 243,000 miles, or a little more than the distance between the earth and moon. The fifth satellite finishes its periodical revolution in four days, twelve hours, fifty-five minutes, at the distance of 340,000 miles. The sixth requires a period of fifteen days, and twenty-two hours and three quarters, and revolves at the distance of 788,000 miles. The seventh, or outermost satellite, requires seventy-nine days and about eight hours to complete its revolution, and its orbit is 2,297,000 miles from the center of Saturn, or more than nine times the distance between the earth and the moon. The orbits of the six interior satellites are nearly circular, and very nearly in the plane of the ring. The orbit of the seventh approaches nearer in coincidence with the ecliptic.

These satellites, like those of Jupiter, undergo frequent eclipses; but on account of their great distance from the earth, these eclipses are not frequently observed. It is evident that such a numerous assemblage of moons revolving around this planet at different distances and in different periods of time, will present a most beautiful, variegated, and sublime appearance in the heavens of Saturn; especially when all the seven satellites happen to appear at the same time above the horizon. Then one will appear as a full moon, another as a crescent, and another with a half moon, or a gibbous phase—one entering into an eclipse, and another emerging from it—the two inner satellites, on account of their nearness to the planet, presenting the largest discs, and the most splendid appearance, and moving with great velocity in their orbits, rapidly passing the other satellites, at different rates of motion, and leaving them behind in their courses. On the surface of Saturn itself, a curious effect will be produced, and a diversified scene presented. The shadows of all objects will be projected in different directions by the different satellites, according to their relative positions in the heavens. One satellite will project the shadow of an elevated object toward the east, another will project it toward the west; a third will make it fall toward the north; and in a variety of other directions, according to the number of satellites above the horizon, and the positions they occupy in the firmament; and the swift motion of the first two satellites will cause the direction of these shadows rapidly to change. In addition to all this variety of celestial scenery there is the grand spectacle produced by the magnificent rings with which the planet is encircled—which we will now endeavor to describe.

## SECTION VII.

### ON THE RINGS OF SATURN.

THESE rings form one of the most wonderful objects connected with the solar system. Galileo,

soon after he had presented his newly invented telescope to the heavens, was the first of mortals who caught a glimpse of this singular appendage to the globe of Saturn: but on account of the want of sufficient power in his telescope, he did not recognize the nature of the object he was contemplating. From what he could discern, he imagined that Saturn consisted of three globes—a larger globe in the middle, and two small globes, one on each side, and all the three nearly touching each other. After viewing this phenomenon for the space of two years, he was amazed, at the end of this period, to find the middle globe left quite alone, and the two smaller globes to have disappeared; but after a period of about a year he again caught a glimpse of them, when they continued visible for about fourteen years in succession. Nearly half a century elapsed before the true nature and form of this extraordinary phenomenon were discovered. During this period many were the strange conjectures which were formed respecting it. Some astronomers thought that the two small globes stuck to the middle globe, others that they were separated from it. Some thought that the phenomenon consisted of one longish body, or ellipsoid, and that it was perforated with a very large hole, or opening on each side. Some imagined that two bodies, each of the form of a crescent, were connected with the body of Saturn, and one placed on each side; and some that the phenomenon consisted of an elliptical ring, but that this ring was attached to the globe of Saturn, above and below. Huygens, in his "Systema Saturnium," presents us with fourteen engravings of the various forms which different astronomers had conceived respecting this appendage to the globe of Saturn, some of which are very curious, and almost ridiculous, yet, in some cases, indicating considerable ingenuity of conception. It was not until about the years 1655 and 1656—forty-six years after the invention of the telescope—that the real nature and figure of this singular phenomenon were discovered by Huygens. This ingenious mathematician and astronomer, in order to settle the disputes on this subject, resolved in the first place, to improve the art of grinding object-glasses, so as to increase the magnifying power of telescopes; and in this he succeeded so far as to make some that magnified two or three times more than those which had been previously in use. With a telescope twelve feet long, and another, twenty-three feet in length—which would magnify nearly a hundred times—and, after a long series of observations, he demonstrated the true cause of those surprising phenomena, which had puzzled all preceding astronomers, and showed to a certainty that Saturn is surrounded with an immense ring, which is entirely separated from its body by an interval of many thousand miles, and that the diameter of the ring, in proportion to the diameter of the planet, was as 9 to 4.

Since the time of Huygens, it has been discovered that this circular arch, which surrounds Saturn, is composed of two concentric rings, separated by an interval of nearly two thousand miles. The following are the dimensions of these rings, as calculated by Sir J. Herschel, from the measurements of Professor Struve, made at Dorpat—by means of the superb micrometer attached to his great telescope:—Exterior diameter of the exterior ring, 176,418 miles; interior diameter of ditto, 155,272. Exterior diameter of the interior ring, 151,690; interior diameter of ditto, 117,339. Equatorial diameter of the body of Saturn, 79,160. Interval between the planet and the interior

ring, 19,090. Interval between the two rings, 1791. Thickness of the rings, 100 miles. These dimensions are considered by some as rather too small. Sir W. Herschel, and all the astronomers who preceded him, estimated the exterior diameter of the exterior ring as above two hundred thousand miles; and Sir John Herschel himself admits, that "the interval of the rings above stated is possibly too small." Still the dimensions here stated convey to us a most astonishing idea of the magnitude and grandeur of those magnificent rings which encompass the globe of Saturn. Sir W. Herschel, by means of several protuberant points connected with the ring, discovered that it has a swift rotation around the globe of Saturn, which it accomplishes in about ten hours and a half—which, reckoning its circumference, according to the lowest dimensions, at 554,234 miles, is a velocity of about nine hundred miles every minute.

This double ring is evidently a solid body, as appears by its throwing a well-defined shadow upon the body of the planet, on the side nearest the sun, and on the other side receiving the shadow of the planet itself,—which is seen, at certain times, by means of powerful telescopes. It is everywhere at least twenty thousand miles distant from the surface of the planet, and yet it is carried along with it in its annual revolution round the sun; and, therefore, if it were not a solid body, it would either fly off from Saturn, or its centrifugal force, caused by its rapid rotation, would dissipate all its parts, and disperse them around the body of the planet. These rings contain, on all their surfaces taken together, an area of more than twenty thousand millions of square miles, which is more than a hundred times the area of our globe. They, therefore, contain ample space for the accommodation of thousands of millions of inhabitants.

In consequence of the immense size of these rings, and the large space they will occupy in the heavens, they will present a magnificent spectacle from those regions of the planet which lie under their enlightened sides, particularly those places which are situated not far from the planet's equator. They will appear as vast arches, spanning the firmament from one part of the horizon to the opposite, and holding an invariable situation among the stars. They will not be visible at the poles of the planet, on account of the convexity of the globe of Saturn interposing between them and the observer; but, near the polar regions, a segment of the rings will appear, presenting a brilliant appearance in the horizon. Advancing from these regions toward the equator, they will appear to span the heavens, like brilliant arches of different degrees of magnitude, until, approaching near the equator, they will appear in the form of complete semicircles. Fig. 49 presents a rude sketch of the rings, as they will appear from such a position, together with a partial view of the nocturnal firmament of Saturn. But no pictorial representation, however ample the scale, can convey even an approximate idea of the august and splendid objects which must diversify and adorn the nocturnal sky of Saturn. For, beside the rings, which will form the most striking and magnificent spectacle, there are seven moons, three or four of which generally diversify the celestial hemisphere, appearing in different positions, and with different phases; and, sometimes, the whole seven satellites may be beheld in one bright assemblage, pursuing their different courses among the stars, and rapidly shifting their positions and aspects.

The views of Saturn and the rings, obtained by

powerful telescopes, are highly interesting and beautiful; but the appearance of the rings is not the same at all times. When seen to the greatest advantage, they appear as represented in fig. 50, where they assume the appearance of ellipses, or ovals, with the planet in the center, and on each side of the planet the dark space or interval be

Figs. 49, 50, 51, 52.

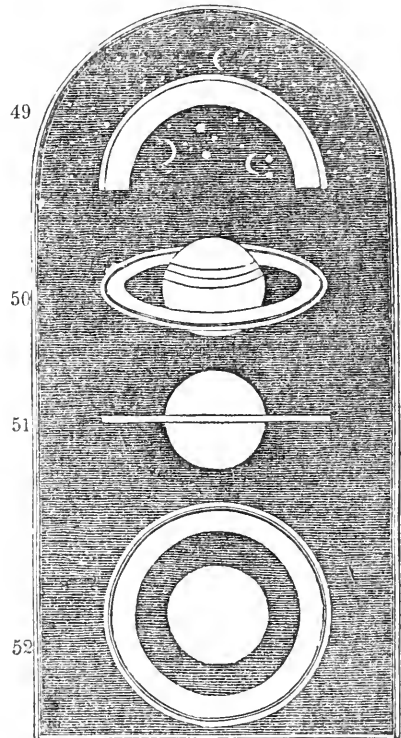

tween the interior ring and Saturn. The division between the rings is indicated by a dark line which seems to go round the ring, which is the empty space by which they are separated. It is only once in fifteen years, however, that the rings appear so open as here represented; and sometimes they are altogether invisible as seen from the earth. This happened in October, 1832; and after being visible for some time, from December, 1832, to April, 1833, the ring again disappeared for two or three months. During this time the only indication which was given of its existence was the shadow of the ring, which appeared like a dark belt across the body of the planet. At present (1846), the rings appear much narrower than what is represented in the figure, though the dark space between the planet and the ring is distinctly visible. In 1847, the ring will appear still narrower—in the beginning of that year, it will appear nearly as in fig. 51, like a line of light on each side of the planet, but without any apparent opening of the ring; in the beginning of 1848, it will entirely disappear, and, in this case, the thin edge of the ring is turned toward the earth, and the planet appears as if it were entirely divested of its magnificent appendage, and to move solitary among the stars. About July or August, of the same year, the ring will again appear, through good telescopes, as a fine thread, or line of light, on each side of

the planet; and, in 1849, the opening of the ring and the dark space between it and the planet, will be distinctly visible. During the years 1850 and 1851, the ring will appear still more expanded, until toward the end of 1854, when it will appear fully expanded, as in fig 50; and, during the other seven years and a half, it will gradually contract until about the end of 1861, or the middle of 1862, when it will again become invisible.

The phenomenon of the disappearance of the ring takes place at intervals of 14 years and 9 months, and happens when the planet is in 170 degrees, and 350 degrees of longitude, or in the 20th degree of Virgo, and the 20th degree of Pisces. The sun shines on the one side of this ring during a period of nearly 15 years, and the regions of the planet, that lie under the dark side, suffer a solar eclipse, under its shadow, during the same period. But there is no doubt that this apparent defect is compensated, not only by the light of the satellites, but by other arrangements, with which we are unacquainted. This planet, with its rings, would exhibit a more splendid and interesting appearance through our telescopes, could we view the rings, not obliquely, but as standing at right angles to our line of vision, as represented in fig. 52. This represents the real position of the rings in respect to the planet; but our eye is never so much elevated above the plane of the rings as to view them in this manner; it is never elevated more than 30 degrees above the planes of the rings, so that we never see the rings more fully expanded than what is represented in fig. 50.

Had our limits permitted, we might have inquired into the ends for which these rings were formed by the Almighty Architect, and the designs they are intended to accomplish in the system of Saturn. But, in consequence of the great distance at which we are placed from this planet, and of our ignorance of many of the plans of the great Creator in his arrangements of the universe, we are unable fully to appreciate all the designs he intended to accomplish, either in this, or in other parts of his operations. There is one object, however, that these rings were evidently intended to accomplish; namely, to throw a light on the regions of the planet in the absence of the sun—to serve the purpose of a thousand moons—to produce a diversified and sublime scenery in the nocturnal sky of Saturn, and to display the glory and magnificence of the Creator. They evidently manifest his power in the amplitude and greatness of their dimensions, in the vast quantity of matter they contain, and in the amazing rapidity with which they revolve around the planet—and his wisdom in nicely balancing and proportionating every minute circumstance in their construction and arrangement, by certain laws, so as to prevent them either from flying off from the planet in its swift career, or from falling down upon its surface, and producing a complete derangement of the whole fabric of this mighty globe—and likewise in preserving them in their exact position, and proper motions, without variation from age to age. They may likewise be intended to teach us in what a variety of modes, inscrutable to us, the Creator may bring into existence numerous worlds, encompassed with celestial machinery and arrangements altogether different from anything we have hitherto contemplated—which may lead us to conclude that, in other systems, and around other suns, worlds may exist diversified with celestial scenery, of which we find no traces throughout the whole range of our planetary system.

But, beside these general designs, we conceive, there is another important end these rings are in-

tended to subserve; namely, to form a habitation for numerous orders of intellectual beings. Wherever matter exists in our world, we find it peopled with different orders of animated existence; and therefore it would be absurd to suppose that the celestial bodies—formed by the same All-wise and Almighty Being—should be altogether destitute of inhabitants. The quantity of surface on the rings is more than twenty-thousand millions of square miles, being more than a hundred times the area of the whole terraqueous globe, and consequently contains ample space for the accommodation of myriads of inhabitants; and it is highly improbable from what we know of the plans of infinite wisdom, that such a space should remain forever as a barren desert, without contributing either to sensitive or intellectual enjoyment. The scenery of the heavens as beheld from the rings, would even be more grand and diversified than that which is beheld from the surface of Saturn, and would afford to intelligent natures a striking display of the perfections of their Creator.

We may just further state, in relation to this planet, that several late astronomers are of opinion that the outer ring of Saturn is divided into several smaller rings. Captain Kater states, in a paper sent to the "Astronomical Society," that on December 17th, 1825, with a reflecting telescope of six feet six inches focus, "he saw the outer ring of Saturn, separated by numerous divisions, extremely close, one stronger than the rest, dividing the ring about equally. Professor Quetelet, at Paris, likewise states, that, with the achromatic telescope of ten inches aperture, "he saw the outer ring divided;" and Decuppis, at Rome, is also said to have observed the same phenomenon. Mr. Lawson, an ingenious astronomer, at Bath, who has lately erected a splendid achromatic telescope, twelve feet long, states, that with some of its higher powers, he has several times observed several divisions on the ring of Saturn. If this magnificent arch is not merely double, but even treble, or quadruple, it presents a still more wonderful idea to the mind, especially if each of the rings have a distinct and separate rotation round the planet. But as the divisions alluded to have not been perceived by other observers in the most favorable circumstances, we must suspend our opinion on this point, until more minute and extensive observations be made, either to disprove or to confirm those which we have now stated.

In concluding our reflections on this planet, it is almost needless to remark, that the planet itself, with all the celestial scenes connected with it, presents to the mind an object of surpassing grandeur and sublimity. Let us suppose ourselves stationed within a few thousand miles of this planet—a station which some superior intelligences may occasionally occupy—from such a position, the globe of Saturn, the rings, and the satellites, would appear to fill the greater portion of the visible heavens. Let us then conceive this planet—a thousand times larger than the earth—flying before us at the rate of twenty-two thousand miles an hour, carrying along with it stupendous rings, five hundred thousand miles in circumference, and these rings revolving round the planet with a velocity of nine hundred miles every minute, and seven other spacious globes, larger than our moon, wheeling their rapid courses, at different distances around the planet and its rings—let us endeavor to stretch our imagination to the utmost, to represent such a scene as nearly as possible to the reality, and suppose ourselves as spectators—how grand and overwhelming, and almost terrific, would be the amazing spec-

tacle! Amidst the emotions it would excite, we could only exclaim, "GREAT AND MARVELOUS ARE THY WORKS, LORD GOD ALMIGHTY!"—"Thy right hand, O Lord, is become glorious in power!"—"Who can utter the mighty acts of the Lord!"—"The Lord God Omnipotent reigneth!" Is it possible to separate such scenes and operations from the idea of an eternal and Almighty intelligence, who formed, and arranged, and set in motion, such stupendous machinery? Could chance, or the fortuitous concurrence of atoms, have ever produced such a portion of celestial mechanism, and preserved it unimpaired in all its relations and movements, from age to age? Such an idea is fraught with the grossest absurdity that ever entered the human imagination. If a Divine superintendent over creation did not exist, the whole frame of universal nature would long ere now have been unHINGED, and the universe, with all its splendid orbs and mighty movements have been transformed into a chaos, and scattered throughout the regions of infinitude. And, "since a God there is, that God how great!" His power is irresistible, his wisdom is unsearchable, and his agency pervades the immensity of space. To refuse to submit to his laws and his moral government must, therefore, expose us to the most dismal consequences. For thousands of means are within the range of his wisdom and intelligence by which the rebels against his authority may be arrested and punished; and his power to execute his purposes no created beings can control. "The mountains quake at him, and the hills melt, and the earth is burned at his presence. Who can stand before his indignation?" "The pillars of heaven tremble and are astonished at his reproof." Happy they who have this Almighty Being as their father and their friend, "who do his commandments, hearkening unto the voice of his word." For all the glories of creation, and all the resources of the universe are at his disposal to contribute to their knowledge and felicity, while ages numerous as the drops of ocean are rolling on.

## SECTION VIII.

### ON THE PLANET URANUS.

UNTIL near the close of the last century, Saturn was considered as the remotest planet from the sun, and his orbit as forming the outermost boundary of the planetary system. But, since the discovery of Uranus, the diameter of the system is doubled, and the area of the space it comprehends is four times the dimensions formerly supposed. Instead of an area of twenty-five thousand millions of square miles—its former supposed dimensions—it now comprehends at least one hundred thousand millions of square miles; throughout every portion of which the influence of the great central luminary extends, and likewise as far beyond as the erratic comet pursues its distant course. It is somewhat strange that, from the time of Huygens and Cassini, when telescopes were brought to a certain degree of perfection, until near the close of the eighteenth century (a period of more than a hundred years), no new discoveries were made in the heavens, when the number of those who cultivated the science of astronomy was increased, and the science itself had received many improvements. But the mind of man has a propensity to indolence when not stimulated by worldly gain, and certain difficulties to be encountered tend to discourage and impede its progress. The long and unwieldy telescopes used

by the astronomers of the seventeenth century were very difficult to manage, and required long exposure to the cold air of the evening, and their attention was chiefly directed to observations on the planetary bodies which were then known. Few observations, comparatively, were made on the fixed stars, so as to ascertain the varieties which exist among them, the changes to which they are subject, or the moving bodies that may be found in the stellar regions; and hence, in part, the reason that so few discoveries were made during that period.

The appearance of the late Sir William Herschel, as an observer of the heavens, formed a new era in the history of astronomy. This illustrious astronomer having viewed the heavens with a two-foot Gregorian telescope, which he had borrowed, was so much interested with the instrument, that he commissioned a friend in London to purchase for him one of a larger size. The price, however, being more than he anticipated, and more than he could afford, he resolved to attempt the construction of one with his own hands; and in this he succeeded. A five-foot Newtonian reflector, which he completed in 1774, was the commencement of that brilliant series of discoveries and improvements which he afterward effected. While residing in Bath he had been engaged for a year and a half in making a regular survey of the heavens, when on the evening of the 13th of March, 1781, he discovered, among other stars one of unusually steady radiance; continuing to watch it, he found, after several observations, a perceptible change in its position, although its motion with relation to the other stars was very slow. Having sent an account of this observation to Dr. Maskelyne, the astronomer royal, it was at first supposed to be a comet, but soon afterward it was ascertained beyond a doubt that it was a new planet which had, in all former ages, eluded the observation of astronomers. For this discovery the Royal Society conferred upon Herschel the honorary recompense of Sir Godfrey Copley's medal; and he named the planet *Georgium Sidus*, in honor of his majesty king George the Third; but the continental astronomers distinguished it by the name of *Herschel*, in honor of the discoverer; and it is now more generally known by the name of *Uranus*. Soon after this discovery, Herschel was taken under the patronage of his majesty, and rewarded with a pension of £300 per annum. He removed to Slough, near Windsor, where, in 1789, he erected his large forty-foot telescope, by which he was enabled to make further discoveries.

The planet *Uranus* is not visible to the naked eye, and requires a certain degree of magnifying power to render it visible as a very small star. We have seen it in this way with a power of twenty times, but it requires a power of at least two hundred times to make it appear like a well-defined visible disc. Its real magnitude, however, is considerable,—being no less than thirty-five thousand miles in diameter, or more than eighty times the size of our globe. Its surface contains three thousand eight hundred and forty-eight millions of square miles,—which is seventy-eight times the area of all the habitable portions of the earth; so that this apparently small body, which had remained unnoticed for thousands of years, adds considerably to the quantity of matter formerly supposed to belong to the solar system. For it contains a mass of matter, as to bulk, more than twenty times larger than what is contained in Mercury, Venus, the Earth, the Moon, Mars, Vesta, Juno, Ceres, and Pallas. Its distance from



the sun is about double that of Saturn,—being no less than eighteen hundred millions of miles. To reach the nearest point of its orbit, a cannon ball, flying from the earth in that direction, at the rate of five hundred miles an hour, would require a period of three hundred and ninety years. It moves round the sun in the space of eighty-four years, in an orbit eleven thousand millions of miles in circumference; at the rate of fifteen thousand miles an hour. The inclination of its orbit to the plane of the ecliptic, is 46 minutes, 28 seconds.

From the immense distance at which this planet is placed from the sun, we might be apt to imagine that there will be a great deficiency of light and heat on its surface. The quantity of light it receives from the sun is about three hundred and sixty time less than what the earth receives; for the quantity of illumination enjoyed in any planet is in an inverse proportion to the square of the distance of the luminous body that enlightens it. The quantity of light on Uranus—notwithstanding its great distance from the sun—will be equal to what we should have, were three hundred and forty-eight full moons continually shining on our globe at one time. But the pupils of the eyes of the inhabitants of this planet may be so constructed as to take in ten or twenty times the quantity of light which our eyes would receive, were we placed in that distant region. And as to sensible heat, it does not appear that this depends on the distance of a planetary body from the sun; but on the nature of its atmosphere, and the substances on its surface on which the rays of light and heat fall. Every part of our globe may be considered as at an equal distance from the sun, and yet there are all the varieties of temperature experienced from twenty degrees below zero in the frozen regions of Greenland, to a hundred degrees above it, in the scorching climes of the torrid zone. On the top of the Andes, in South America, there is the most intense cold, and perpetual snows; while in the plains below excessive heat is felt under the rays of a tropical sun, while only a few miles intervene between the respective localities. At any rate, we may rest assured that, throughout all the regions of the universe, the Creator has displayed his wisdom and goodness in adapting the structure and constitution of the inhabitants to the nature of the habitation he has provided for them.

In consequence of the great distance of this planet, no discoveries have been made on its surface; no spots have been seen to indicate a rotation, and therefore the period of its revolution round its axis is unknown. But the same illustrious astronomer who first detected it, soon after discovered no less than six satellites which revolve around it. The following table contains a list of these satellites, with their distances from Uranus, and their periods of revolution.

1st, or nearest to Uranus,	Period.	Distance.
5d. 21h. 25m.		239,000 miles.
2d,	8 17 1	298,000
3d,	10 23 3	348,000
4th,	13 10 56	399,000
5th,	38 1 48	777,000
6th,	107 16 40	1,597,708

It is somewhat remarkable, that these satellites, instead of moving from west to east, or in the direction of all the other planets and satellites, have their orbits nearly at right angles to the ecliptic, and move in a direction from east to west. These are exceptions to the general laws of the planetary system which it is difficult to explain. But they occur at the farthest limits of the solar system,

perhaps to teach us, that in other systems arrangements may exist very different from those we experience in the system to which we belong.

## SECTION IX.

### GENERAL REMARKS ON THE SOLAR SYSTEM.

SUCH is a brief description of the principal phenomena connected with the planetary bodies which compose the solar system. We have no reason, however, to conclude that all the planets belonging to our system have yet been discovered. Were a planet of double the magnitude of the Earth revolving between the orbits of Jupiter and Saturn, it would be altogether invisible to the naked eye, and might revolve for thousands of years without being observed by the inhabitants of our globe, unless astronomers were to make a minute survey, with powerful telescopes, of the whole range of the zodiac, in which most of the planets are found to move, along with portions of the celestial regions on either side of it. If the inhabitants of Jupiter and Saturn have no better eyes than ours, and no artificial helps to vision, they must be altogether ignorant that such a globe as the earth exists in the universe, nor will they ever obtain a glimpse of either Mars, Mercury, or Venus. Considering the distance that intervenes between Jupiter and Saturn, it is not at all improbable that one or more planets may exist in the interval; and since no less than 900 millions of miles intervene between the orbits of Saturn and Uranus, several planets, much larger than the earth, may revolve in those regions, which the keen eyes of astronomers have never yet detected. Even within the orbit of Mercury a planet may exist, which we may never be able to discover, on account of its nearness to the sun, being at all times immersed in the effulgence of the solar rays. Our views of the universe and its arrangements are only beginning to open and expand; but in the ages to come, if art and science still advance, objects of which we have no conception at present may be disclosed to view, even within the bounds of the planetary system.

Throughout the whole of this system we perceive *order* and *harmony* prevailing without interruption. While the planets are prosecuting their courses with amazing velocity, and moving onward in their respective spheres without a moment's pause—while their attractive forces on each other sometimes produce slight perturbations—while one sometimes interposes between the sun and another, and casts a transient shade over its surface; yet no disorder or confusion ever occurs throughout the system: every orb finishes its respective circle of revolution in exactly the period of time in which it has been performed for thousands of years; no one ever interrupts the course of another; no satellite ever forsakes its primary, in the course of its rapid movement; but the laws of motion originally impressed upon all the bodies of the system continue to operate as they have done from the beginning. These circumstances evidently demonstrate the existence of a presiding Intelligence, who at first formed and arranged this magnificent system, and who every moment sustains it in all its movements. It would be easy to show—if this were the proper place for it—that unless an Immaterial Power continually re-excited motion in the material universe, all motion would stop in a very short time—perhaps in less than an hour—except that the planets would run out in right-lined directions;

and then nothing would ensue but confusion, darkness, silence, and chaos. For matter of itself can pursue no end, obey no law, nor change the direction of its motion. If, then, a presiding Divinity is continually exerting his attributes, impressing every part of that universe to which he gave existence, we cannot deny his title to supreme dominion; and, if so, we must acknowledge that all praise, adoration, submission, and obedience are due to Him who hath created all things, and for whose "pleasure they are and were created."

It may likewise be remarked, that amidst all the varieties which characterize the planetary system, there are evident marks of unity and mutual relationship. The distances of the planets from the sun, vary from thirty-seven millions to one thousand eight hundred millions of miles. The quantity of light that falls on the surface of Mercury is two thousand four hundred times more intense than that which falls on Uranus. In point of magnitude some of the planets are several thousand times larger than others; and as to the times of their revolutions, their periods vary from eighty-eight days to eighty-four years. Some have one accompanying moon, some have four, some have seven, and others are destitute of such appendages. Yet a family likeness pervades the whole. The figure of all the planets is nearly the same; they are all either globes or spheroids; they all move round their axes, and round the same central luminary, producing an alternate succession of day and night, and, in most instances, a variety of seasons. Most of them, if not the whole, are environed with atmospheres; and on their surfaces, mountains and plains, hills and vales, have been described, and the law of gravitation pervades and governs the whole. One sun enlightens every member of this system, whether primary or secondary; and although this luminary appears to one planet seven times larger than to us, and to another a hundred times smaller, yet it serves all the purposes of a sun to diffuse that degree of light and splendor and benign influence which is requisite for the comfort of each respective planet. These and other circumstances plainly indicate that one Supreme Mind contrived this system of moving bodies, and superintends, directs, and governs the whole. For two or more supreme beings—whose plans and purposes might clash—could never be the parents of that harmony and unity of design which we perceive throughout the system of nature. Such considerations, likewise, lead us to conclude that all the planets of this system are destined to subserve in their respective spheres the same grand purposes, namely, to serve as comfortable habitations for numerous orders of sentient and intellectual beings, capable of knowing and adoring the perfections of their great Creator. For the material world could never be shown to manifest the wisdom and intelligence of its Author and Contriver, if this position were denied. For it would then exhibit only a stupendous system of means without an end, corresponding to the magnificence of the operations employed; and, in this case, there would be no extensive display of the riches of Divine beneficence.

*Illustrations of the distances and magnitudes of the Planets.*—Sir J. Herschel proposes the following illustration, to convey to the minds of general readers an impression of the relative distances and magnitudes of the parts of the solar system:—"Choose any well-leveled field or bowling-green: on it place a globe two feet in diameter—this will represent the sun; Mercury will be represented by a grain of mustard seed, on the circumference

of a circle one hundred and sixty-four feet in diameter for its orbit; Venus, a pea, on a circle of two hundred and eighty-four feet in diameter; the earth, also a pea, on a circle of four hundred and thirty feet; Mars, a rather large pin's head, on a circle of six hundred and fifty-four feet; Juno, Ceres, Vesta, and Pallas, grains of sand, on orbits of from a thousand to a thousand and two hundred feet; Jupiter, a moderate-sized orange, on a circle nearly half a mile across; Saturn, a small orange, on a circle of four-fifths of a mile; and Uranus, a full-sized cherry or small plum, upon the circumference of a circle more than a mile and a half in diameter."

From this illustration it appears, that an orrery to represent both the proportional distances and the proportional magnitudes of the sun and planets would require to be more than a mile and a half in diameter, and nearly five miles in circumference; and, in this case, scarcely any of the planets would be visible from the center. Our common orreries and planetariums can exhibit only the relative motions of the planets, and the order in which they are placed from each other in the system; but they can present no accurate or comprehensive idea of their proportional distances or magnitudes; and the balls which represent the sun and planets being so small, and placed so near each other, have a tendency to produce erroneous conceptions. The comparative distances and the comparative magnitudes can only be separately exhibited on a small scale. The following is a simple method by which we have frequently exhibited the proportional distances of the planets. Provide a small square rod about eight feet long, at one end of which place a ball or other object to represent the sun. At two inches from the sun's ball, place a ball to represent Mercury; at three inches and a half, Venus; at five inches, the earth; at seven inches and a half, Mars; at thirteen inches, Ceres, Pallas, Juno, Vesta, almost close to each other; at twenty-five inches, Jupiter; at forty-seven inches, or about four feet, Saturn; and at eight feet, Uranus. These proportions will convey an approximate idea of the relative distances of the planets from each other and from the sun; and if wax tapers were placed instead of the balls, and lighted, these comparative distances might be exhibited to a large audience. The proportional magnitudes might likewise be exhibited as follows:—Suppose a globe of eighteen inches diameter to represent the sun, Jupiter will be represented by a ball one inch and four-fifths diameter; Saturn, one inch and two-thirds; Uranus, three-quarters of an inch; the Earth, one-sixth of an inch; Venus, one-sixth of an inch; Mars, one-eleventh of an inch; Mercury, one-fifteenth of an inch; Moon, one-twenty-fourth of an inch; Ceres, Pallas, Juno, Vesta, by small pin heads. The following numbers may assist the memory in recollecting the proportional mean distances on the planets. Suppose the distance of the Earth from the Sun to be divided into 10 parts—Mercury may then be estimated at 4 of such parts from the Sun; Venus at 7; the earth at 10; Mars at 15; the new planets, Ceres, Vesta, etc. at 26; Jupiter at 52; Saturn at 95; and Uranus at 196 such parts.

*Method of acquiring an approximate idea of a million units.*—In the preceding description of the solar system, the distances of the sun and planets, and the extent of the planetary orbits, have been expressed by millions of miles. But however accurately such distances and dimensions may be considered as stated, the mind is unable to form a

SUMMARY VIEW OF THE SOLAR SYSTEM.

The following Table exhibits, at one view, the distances, diameters, periods of revolution, etc., of the Planets, and other permanent elements of the Solar System.

Names of the Planets	Distances from the Sun, in Miles.	Diameters, in Miles.	Periods of Revolution round the Sun.	Rotation on Axes	Mean annual Diameter, in Seconds, etc.	Velocity in Orbit per Minute	Inclination to the ecliptic.	Inclination of Planets' Equator to the Ecliptic.	Density, that of Water being 1.	Mass, that of the Earth being 1.	Diameter of the Sun, seen from the Planets.
Sun.	37,000,000	880,000	—	25d. 10h.	32' 3"	1820	7°	7° 20'	1.2-15	354936.	80'
Mercury.	68,000,000	3,200	88 days	24h. 6m.	8" 5	1333	3° 23'	9 1-6	9 1-6	0.16	46'
Venus.	95,000,000	7,800	221 —	23h. 20m.	35"	1133	3° 23'	5 11-13	5 11-13	0.94	32'
Earth.	95,000,000	7,800	365 1/4	23h. 56m.	31' 8"	833	5° 8' 47"	23° 28' 4 1/2	1.	1.	32'
Moon.	95,000,000	2,180	—	27d. 8h.	11"	733	10 51'	29° 30' 3 2-7	0.013	0.013	21'
Mars.	145,000,000	4,200	6-6	24h. 40m.	0" 5	733	7° 8'	13'	0.13	0.13	13'
Jupiter.	495,000,000	89,000	11y. 315d.	9h. 56m.	3"	683	13° 5'	13° 5'	13'	13'	13'
Saturn.	906,000,000	79,000	29 1/2 years	10h. 16m.	1"	683	10° 18'	9	2	338	6'
Uranus.	1,820,000,000	35,000	84 years	—	0" 5	366	2° 20'	3° 5'	1.24	120	3'
					4"	250	0° 46'	0 99-100	0 13-32	17	1'

distinct and comprehensive idea of such vast distances and dimensions, and even at its utmost stretch, and with all its efforts, must be contented with a very vague and indefinite conception of the immense spaces of the heavens. This is partly owing to our want of a clear and comprehensive idea of the number of units contained in a single million. We can form a clear idea of a hundred units, and even of a thousand; our ideas of ten thousand, fifty thousand, and a hundred thousand

are less clear and definite; and it is but a vague idea we generally have of ten hundred thousand, or one million, when we attempt to grasp it at one conception. We may assist our conceptions a little by such illustrations as the following:—A million of pounds would be sufficient for the formation of 5000 miles of road, at the rate of £200 for each mile—which would be sufficient to reach from the Land's End of England to the northernmost point of Scotland, to go quite round the island of Great Britain, and to cross it in different directions. The same sum would be sufficient to rear more than 666 churches, at £1500 each; It would be adequate to the building and furnishing of 2500 schools, at £400 each. Were a man to count a million sovereigns, one by one, and allow only a single second for each sovereign, and continue, without intermission, 12 hours every day, it would require more than 23 days before such a sum could be counted; and, consequently, to count in the same manner 800 millions of sovereigns, the amount of our national debt, would require more than fifty years! Were a million of men to be arranged in a straight line, similar to a line of soldiers when on parade, and three feet allowed for the breadth of every man, that line would extend over a space of more than 563 miles in length—in other words, it would extend over the whole length of the island of Great Britain, from the Straits of Dover to the Orkney Isles. Such illustrations may help to assist the mind a little in forming its conceptions of the number of units contained in a single million; to which we may add the following—that a line a million miles in length would go forty times round the circumference of the earth; and that, since the creation of the world, little more than two million of days have elapsed.

Mr. Henry Martin, teacher, Chatham, has lately contrived a plan by which a million of units may be represented to the eye, and which produces a more striking effect than any plan hitherto adopted. It consists in the arrangement of spots of the size of those in the annexed figure. They are arranged in squares, in the manner here represented—every square containing one hundred spots. There are a hundred squares on a sheet of foolscap, which, of course, contains ten thousand spots or units; and there are one hundred of these sheets pasted on a piece of calico, which doubles up like a long map, a small space being left between each sheet, that the calico may form a hinge for doubling. The number of spots on these hundred sheets amounts to 10,000×100, or exactly a million. This representation of a million of units, were it to be exhibited in the

Fig. 53.

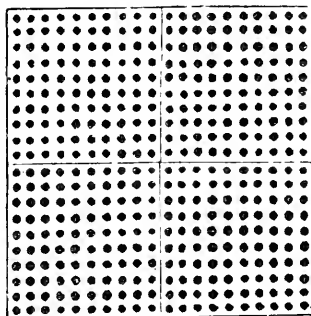

most striking manner, should be stretched along the side of a large room, 8 feet high and 14 feet

long, which it would completely fill; or on any surface about  $10\frac{1}{2}$  feet square, and containing an area of about 108 square feet. The annexed figure contains 400 spots, which are only the 1-2500th part of a million, so that it requires two thousand five hundred times the space and the number of spots contained in this figure to represent the units in a million. On beholding such a number of units or spots, as close to each other as those in the figure, and covering such a large space, the mind is struck with wonder at the number of units which a single million contains; and Mr. Martin informs me that "all persons, who have seen it, have expressed themselves much astonished at the vastness of it." Were each square, containing 100 spots, exactly of the same size as in the figure, placed along side each other, in a straight line, that line would extend above a thousand feet in length.

When beholding such a number of units compressed together, and yet filling so great a space, we might be apt, at first view, to consider it as a faint picture, or emblem, of immensity and eternity. But what is one million compared with hundreds and thousands of millions? That sun, which enlightens our day, is ninety-five millions of miles distant from us. The planet Uranus is one thousand eight hundred millions of miles distant from the sun, and yet is within the reach of his illuminating and attractive influence. Such immense distances are comprised even within the limits of the planetary system. How overwhelming, then, to consider the distance of the nearest stars! That distance is not less than twenty billions of miles; and let it be remembered that each billion contains no less than ten hundred thousand millions. And as to magnitudes, we are almost equally overpowered at the idea of their immensity. The sun contains, on his surface, two bil-

lions, four hundred and thirty thousand eight hundred millions of square miles; and his solid contents comprehend more than three hundred and forty-six thousand billions of cubical miles. And the sun is only one out of a hundred millions of similar globes which compose the visible universe; and, beyond all that is visible to human eyes, orbs of astonishing grandeur may exist, whose number may exceed the number of the sands that lie along the sea-shore. Hence the necessity of endeavoring to form as large and extensive an idea as possible of the number of units contained in a million, if we wish to take a comprehensive view of the immense spaces of the heavens, and the magnitude of the celestial orbs. For a million, great as this number is, forms, as it were, but a unit to thousands, tens of thousands, and hundreds of thousands of millions—to billions, trillions, and other higher numbers that sometimes enter into astronomical calculations.

What a vast and overpowering assemblage of human beings must be presented to view at that solemn day, when all the men and women, that have ever dwelt on the surface of our globe, shall appear in one great assembly before "God, the Judge of all!" The number that have already dwelt upon the earth, since the formation of the first man, is at least, one hundred and forty-six thousand two hundred millions; and, probably, more than double that number may appear before that decisive day draws nigh. The idea of such an assemblage of beings is absolutely overwhelming to our limited powers of conception. It may be proper, however, occasionally to ruminate on such subjects, as it is one of the principal modes by which we may acquire comprehensive views of the vast extent of creation, and of the ineffable glory and magnificence of the great Creator

## CHAPTER V.

### ON COMETS.

BESIDE the planetary bodies described in the preceding chapters, there is a class of celestial bodies, considered as connected with the solar system, which have obtained the name of comets. The word comet is derived from the Greek *κωμη*, and the Latin *coma*, both of which signify the hair, and a comet was so denominated, because the lucid haze with which the body of a comet is attended sometimes resembles flowing hair. As comparatively little is known of the nature and destination of these erratic bodies, we shall just offer a very few remarks on what has been ascertained respecting their phenomena and motions.

Comets are distinguished from the planets and fixed stars by being usually attended with a long train of light, tending always opposite to the sun, which is called the tail, and which is of a fainter luster the farther it is from the body of the comet.

The luminous point near the center or head of a comet, whence the tail seems to proceed, is called the nucleus, which appears to be the densest part of the comet. The tail of a comet at its first appearance is very short, and increases as it approaches toward the sun. Immediately after its perihelion, or nearest approach to the sun, the tail is longest and most luminous, and is then generally observed to be somewhat bent, and to be convex toward those parts to which the comet is

moving; the convex side being rather brighter and better defined than the concave side. When the tail has attained its greatest length, it quickly decreases, and vanishes entirely from the sight about the same time that the comet itself ceases to be visible. Of what kind of matter the tail consists has been matter of conjecture, and various opinions have been broached on this subject but nothing is certainly known respecting it. It is evident, however, whatever may be the matter of this substance, that it is exceedingly rare, and so very pellucid that the light of the smallest stars suffers no sensible diminution in passing through it. Sir J. Herschel says, that he "could distinguish stars of the sixteenth magnitude, through the thickest part of a comet, as it passed over them, covering them with perhaps 50,000 miles of cometic matter."

The tails of comets are found sometimes to occupy an immense space in the heavens. The comet of 1680 stretched its tail across an arch of 104 degrees, and the tail of the comet of 1769, subtended an angle of 70 degrees. The real length of the tail of the comet of 1680, was estimated at 112 millions of miles; that of 1769, at 44 millions, and that of 1744, at eight millions of miles. Sir W. Herschel estimated the length of the tail of the great comet which appeared in 1811, at one hundred millions of miles, a space larger

than the whole distance between the earth and the sun; and its breadth was calculated at about fifteen millions of miles. We may just simply mention the opinions of different philosophers, respecting those long trains of light. Tycho Brahe supposed them to be the light of the sun transmitted through the nucleus of the comet, which he believed to be transparent like a lens. Kepler thought that the impulsion of the solar rays drove away the denser parts of the comet's atmosphere, and thus formed the tail. Sir I. Newton supposed that it is a thin vapor, raised by the heat of the sun from the comet. Euler maintained that the tail is occasioned by the impulsion of the solar rays driving off the atmosphere of the comet, and that the curvature observed in the tail is the joint effect of this impulsive force, and the gravitation of the atmospheric particles to the solid nucleus. Mairin imagined that comets' tails are portions of the sun's atmosphere. Dr. Hamilton supposed them to be streams of electric matter. Biot, the French philosopher, supposes that the tails are vapors produced by the excessive heat of the sun, and also that the comets are solid bodies before they reach their perihelion, but that they are afterward either partly or totally converted into vapor by the intensity of the solar heat. Notwithstanding these opinions of eminent philosophers, we must still admit that the true cause of the extraordinary phenomenon of the tails of comets remains yet unknown. When we consider that these vast streams of light extend, in some instances, to eighty and a hundred millions of miles in length, we cannot conceive that any of the causes assigned above will account for such a wonderful phenomenon. If they consist of vapor raised from the comet, why should this vapor extend to such a prodigious length through space, and why should it be illuminated throughout its whole extent? for if it were opaque, or unilluminated vapor, it would be invisible.

In ancient times, comets were generally supposed to be meteors, or exhalations, generated by inflammable vapors in the earth's atmosphere. But it is now ascertained, beyond a doubt, that comets move in regions far beyond the limits of our atmosphere, and form a portion of the solar system. But they differ in many respects from the various planetary bodies, formerly described. In regard to planets, their orbits are all confined to a certain zone, or region of the heavens, of no great breadth, except in the case of Pallas. This zone, in the case of the old planets, contains about eight degrees on each side of the ecliptic. But the orbits of the comets cut the ecliptic in every direction, and, in some instances their orbits are directly perpendicular to it. They likewise differ from the planets in the form of their orbits. The orbits of most of the planets, though elliptical, approach very nearly to circles; but those of comets are long narrow ellipses, whose length is many times greater than their breadth, and, in most cases, the full extent of their elongation cannot be traced. Only one small portion of these orbits lies within the limits of our observations, and their remotest boundaries are far beyond the range of human vision. Hence it is, that we perceive a comet only for a very short time, and during a very small part of its course, the remaining parts of its course being performed in regions beyond the reach even of our telescopic vision, and beyond the orbit of the remotest planet.

The following are some of the more remarkable comets which have appeared within the last century and a half. The most splendid of these bodies which have appeared in modern times was the

comet of 1680. The tail of this comet is said to have reached from the zenith to the horizon, an extent of ninety degrees. When nearest the sun it was calculated to have been within 150,000 miles of his surface, and its rate of motion at that time was computed at about a million of miles an hour. The period of its revolution round the sun was calculated at 575 years; and if this computation be correct it will not again visit this part of the system until the year 2255. Another comet which has excited a considerable degree of interest and attention, is that which appeared in 1682, and is known by the name of Halley's comet. Dr. Halley computed the period of this comet at 75 or 76 years, and predicted that it would again appear about the end of 1755, or the beginning of 1759. It accordingly arrived at its perihelion on the 13th March, 1759. If 76 years be the real period of this comet, then it behooved to re-appear in 1835, which happened accordingly. It was seen at Rome on the 5th of August of that year, and arrived at its perihelion on the 16th November. The period of this comet then is determined, and it is proved, at the same time, that comets are permanent bodies belonging to the solar system. At the remotest point of its orbit, this comet is computed to be 3,400,000,000 of miles from the sun, or nearly double the distance of Uranus.

Another brilliant comet appeared in 1744, the diameter of the nucleus of which was nearly equal to the apparent disc of the planet Jupiter; and its tail, which was divided into six streams of light, was reckoned to be 23,000,000 of miles in length. In 1807, a large comet made its appearance in the month of October, and continued to be visible to the naked eye for nearly two months. The diameter of its nucleus was calculated by Schroeter to be 4600 miles, and the diameter of its coma, or nebulosity surrounding the nucleus, 120,000 miles; its motion was frequently at the rate of 55,000 miles an hour. A still more splendid comet made its appearance in September, 1811, which was visible to the naked eye for more than three months in succession. Schroeter computed the diameter of this comet at 50,000 miles, and Sir W. Herschel estimated the length of its tail at 100,000,000 of miles. When nearest the earth it was distant about 113,000,000 of miles. We shall notice only two other comets, remarkable on account of the shortness of their periods. The first of these comets to which I allude is called the Encke comet, from Professor Encke, who first ascertained its period. It performs its revolution in a period shorter than that of any comet yet known; namely, in 1200 days, or three years and three-tenths. Its orbit penetrates within the orbit of Mercury, but does not extend so far as the orbit of Jupiter. It is a very small body, and is scarcely distinguishable by the naked eye. The other comet is that of Biela, sometimes called Gambart's comet, which finishes its revolution in a period of 6 $\frac{3}{4}$  years. It was seen in 1826, 1832, and 1839, and in February and March, 1846. It is likewise a very small comet, and cannot be seen without a telescope.

The number of comets has been estimated to be very great. Seven or eight hundred of these bodies have been observed in different ages; but there are only a little more than a hundred of them, the elements of whose orbits have been accurately calculated, so as to identify them should they again make their appearance. By far the greater number are invisible to the naked eye, and even beyond the reach of telescopes, and many of them, doubtless, pass along our hemisphere in the day-time, when they cannot be perceived.

From calculations formed on probable grounds, M. Arago concludes that the number of comets which visit the solar system within the orbit of Uranus, is at least 3,000,000. Of late, within the space of fourteen months, five or six comets have made their appearance; one in December, 1843, in the constellation of Orion, another in August, 1844, not far from the star Arcturus, in the constellation Bootes; a third was seen in September of the same year, near the constellation Cetus; a fourth was seen in the month of January, 1845, in the West Indies and which was visible to the naked eye, but was not seen in this country on account of its great southern declination; a fifth was seen in this country in February, 1845, near the constellation of Ursa Major, and about the same time another was said to have been seen in the East Indies. We had an opportunity of seeing two of these comets, but they were both invisible to the naked eye.

In former ages, the appearance of a comet was viewed as the forerunner of disastrous events, such as wars, famine, pestilence, the revolutions of nations and empires, the death of kings and princes, inundations, earthquakes, and similar calamities. But we need scarcely say that there is not the least foundation for such apprehensions; for comets are every year making their appearance to the astronomical observer, while both the physical and the moral world is moving on in its regular course. The comets are, doubtless, messengers of the Deity sent forth to accomplish the designs he intended in their creation; but we have not the least reason to believe that they were ever intended to "shake from their horrid hair" wars, famine, and pestilence upon the nations. Their destination, whatever it may be, must be in full accordance with the benevolence of him whose "tender mercies are over all his works." It has, indeed, been apprehended by some that a comet in crossing the path of the earth, might happen to come into collision with it, and produce a shock which would shatter its present constitution, and prove destructive to its inhabitants. It is admitted that this is a possible circumstance, though the chances in favor of it, according to Arago, are only as one to 281,000,000. In France and other parts of the European continent, in 1773, an apprehension of this kind was excited, which was attended with many serious consequences. People of weak minds, it is said, died of fright, and women miscarried. A similar alarm was produced in 1832, when it was announced that the comet of Biela, on the 29th of October, would cross the plane of the ecliptic at a point near where the earth would be on the 30th of November following; but before the earth arrived at that point, the comet was distant from it 50,000,000 of miles. All such forebodings and alarms may be considered as entirely

without foundation. At least, the believer in Divine revelation has nothing to fear, for he knows that the purposes of the Almighty in respect to this world are not yet nearly completed, and that many of the most prominent predictions of inspired prophets are not yet accomplished. Wars must cease to the ends of the earth. The knowledge of Jehovah must cover the earth. The Jews must be converted to the faith of Messiah. The kingdoms of this world must "become the kingdoms of our Lord, and of his Christ," and righteousness and praise must spring forth before all nations, before a comet or any other celestial agent shall be permitted to impinge upon our globe, or to alter its present constitution; and centuries must necessarily elapse before such objects are fully accomplished.

As to the destination of comets, or the purposes they are intended to serve, in the economy of the universe, we are in a great measure ignorant, as we are unacquainted with the nature and constitution of these singular and anomalous bodies. But as they are all the workmanship of Him who is "wonderful in counsel, and excellent in working," they must be intended to subserve important purposes in the system of creation, worthy of the perfections of Him who is infinite in knowledge, who "established the world by his wisdom, and hath stretched out the heaven by his understanding." So many thousands, or even millions of these blazing orbs, as are continually traversing the regions of the planetary system, were not created in vain. The adjustment of their motions, and the arrangement of their orbits, so as not to interfere with each other, nor with the motions of the planets, is an evidence of that Divine wisdom which is displayed throughout every part of creation. The number of these bodies, the vast magnitude of their blazing tails, and the amazing velocity with which they move in certain parts of their orbits, display the Almighty power of Him who at first set them in motion: and although we are partly ignorant of the ultimate designs they are intended to accomplish, yet we may rest assured that they form a part of that plan of Divine beneficence, which appears a prominent object in all the works of God. There seems no improbability in the supposition, that they are intended as habitations for various orders of intellectual beings, to whom the Almighty displays himself in a peculiar manner, different from that of the inhabitants of the planets, and whose corporeal organization is exactly adapted to the nature and properties of the world in which they are placed. For we have every reason to believe that an infinite variety exists in the universe, in respect both to the physical and mental constitution of the intelligences it contains.

## CHAPTER VI.

### ON THE ECLIPSES OF THE SUN AND MOON.

The term eclipse is derived from a Greek word, which signifies to be diminished, to faint away, to swoon, or to die. When the full moon, in her greatest luster, is deprived of the beams of the sun, she appears pale and languid, as if she were sick and dying. Hence the superstitious among the ancients imagined that the moon was in pain at such times, and therefore lunar eclipses were called the labors of the moon; and in order to relieve her in that fancied distress, they were accustomed to hold up on high lighted torches; to blow with horns and trumpets; to make a loud noise, by beating on vessels of brass and iron, to break, if possible, the enchantment that had fallen on the lunar orb. Before the true causes of eclipses were ascertained, those phenomena were considered as supernatural, and viewed with apprehension and alarm. It was believed that they were produced by the immediate interposition of God, as a token of his displeasure. When the sun was totally eclipsed, it was imagined, by many of the ancients, that he turned away his face, in abhorrence of some atrocious crime that had been committed, or was about to be perpetrated on the earth, and threatened mankind with everlasting night. When the Medes and Persians, several centuries before Christ, were preparing to engage in furious combat, they were so alarmed at an eclipse, which happened at that time, that the warriors on both sides laid down their arms, and entered into a treaty of peace. When the fleet of Pericles, the celebrated Grecian, was preparing to attack Peloponnesus, there happened an eclipse of the sun, which was considered as a most unfortunate omen; and the whole of the Athenian commanders and their men were thrown into the greatest consternation. Such facts should inspire us with gratitude for the advantages we now enjoy, in a land where science is cultivated, and useful knowledge disseminated, and where the light of Divine revelation has dispelled the darkness and superstitions of the heathen world.

Every planet and satellite is enlightened by the sun, and, consequently, casts a shadow toward the point of the heavens which is opposite to that luminary. An eclipse, therefore, is a privation of the light of the sun, or of some other heavenly body, by the interposition of another body between it and our sight. Eclipses are either of the sun, or the moon, or of the satellites which accompany some of the planets. In regard to circumstances, they are divided into total, partial, annular, and central. A total eclipse is when the whole face of the luminary is darkened; a partial eclipse is one when only a part of the disc is darkened; an annular eclipse is when the whole is darkened except a ring, or annulus, which appears round the dark part like an illuminated border. This can only happen in the case of an eclipse of the sun. In a central eclipse, the centers of the two luminaries and that of the earth are in one and the same right line, as when in an eclipse the moon passes through the center of the earth's shadow.

### SECTION I.

#### ON THE ECLIPSES OF THE MOON.

An eclipse of the moon is produced by the interposition of the earth between the sun and moon, and, consequently, it can only happen at the time of full moon, when the moon is in opposition to the sun. As the earth is an opaque body, enlightened by the sun, it will cast a shadow toward those portions of space which are opposite to the sun, and if the moon happen to pass through those spaces where the shadow falls, she must necessarily be eclipsed. The sun and the earth are both spherical bodies, and, therefore, if they were of an equal size, the shadow of the earth would be cylindrical, as in fig. 54, and would continue of the same breadth, at all distances from the earth, and would extend to an equal distance, and might cause an eclipse of the sun to the superior planets. If the sun were less than the earth, the shadow would expand, and grow wider the farther it was from the earth, as in fig. 55. It would reach the orbits of Mars, Jupiter, Saturn, and Uranus, and eclipse them, when the earth interposed between them and the sun; and these eclipses, in the case of the most distant planets, would be of long duration, on account of the shadow being broader in proportion to the dis-

Fig. 54.



Fig. 55.

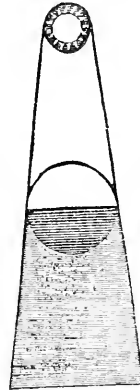

Fig. 56.



tance. But as such eclipses never happen, it forms a demonstrative proof that the sun is not less, but greater than the earth. The sun, then, being greater than the earth, the shadow of the earth is a cone, which ends in a point at a certain distance from the earth, as represented in fig. 56. This cone reaches to a distance of 842,000 miles from the earth, or about three and a half times as long as the distance of the moon from the earth.

If the moon always moved in the plane of the ecliptic, she would suffer a total eclipse, at the

time of every full moon, by passing through the center of the earth's shadow. But the moon's orbit is inclined to the plane of the ecliptic, at an angle of  $5^{\circ} 8'$ , and coincides with it only in two places, called the nodes, or the points where her orbit intersects the ecliptic. Full moon, therefore, may frequently happen without an eclipse, as at this period the moon may be either to the north or the south of the ecliptic. It has been calculated, that if the mean opposition of the sun and moon, or the full moon, happen within  $7^{\circ} 47'$  of the moon's node, there must be an eclipse; but if the distance be greater than  $13^{\circ} 21'$ , there can-

not be an eclipse. Let  $u g$ , fig. 57, represent the moon's orbit,  $EF$  the plane of the ecliptic, and  $N$  the node of the orbit, or point where it cuts the ecliptic; and  $A B C D$  four representations of the earth's shadow in the ecliptic. It is obvious that when the shadow is at  $A$ , and the moon at  $I$ , there will be no eclipse, because the moon is too far from the node, and the earth's shadow does not reach her. When the full moon is nearer to the node, as at  $K$ , only a part of her disc passes through the shadow, when she suffers a partial eclipse. When the full moon is at  $L$ , she passes through a portion of the shadow, and is totally

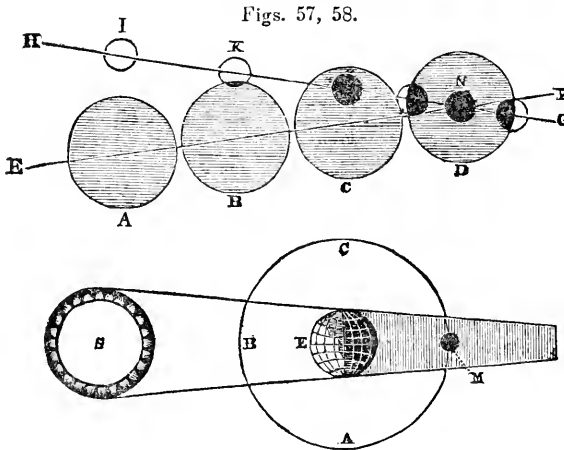

eclipsed. When the moon's center passes through the center of the shadow, which can only happen when she is in the node at  $N$ , it is then both a total and a central eclipse; and such an eclipse is of the longest duration—at which time the total darkness continues about two hours.

Fig. 58 represents, in a different point of view, a total eclipse of the moon. The circle  $A B C$  represents the orbit of the moon, in which it revolves round the earth. The moon is supposed to be in the node, and in her opposition to the sun—she therefore passes through the center of the earth's shadow. And as the shadow of the earth is nearly 6000 miles broad at the distance of the moon, and as the moon is only a little more than 2000 miles in diameter, she must be completely immersed in the shadow of the earth, and must move nearly three times her own diameter before she can emerge from the shadow.

The following facts may be stated in relation to lunar eclipses:—1. An eclipse of the moon always begins on the moon's eastern side, and goes off on her western side. 2. Lunar eclipses are visible in all parts of the earth which have the moon above their horizon, and are everywhere of the same magnitude and duration. 3. The moon's diameter is supposed to be divided into twelve equal parts called digits, and as many of these parts as are darkened by the earth's shadow, so many digits is the moon said to be eclipsed. The extent in which the moon is eclipsed above twelve digits shows how far the shadow of the earth is over the body of the moon on that edge to which she is nearest at the middle of the eclipse. 4. The moon, when totally eclipsed, is not invisible, if she be above the horizon and the atmosphere clear; but appears generally of a dusky color, somewhat like tarnished copper, especially toward the edges, being generally more dark about the

middle of the earth's shadow. Some have supposed this to arise from the moon's native light, but the true cause of her being visible is, the scattered beams of the sun bent into the earth's shadow, by passing through its atmosphere. The moon is not eclipsed by the earth alone; the atmosphere, by refracting some of the rays of the sun, and reflecting others, casts a shadow, though not so dark a one as that which arises from an opaque body. Although in most lunar eclipses the body of the moon, though obscured, is still visible, yet it has sometimes happened otherwise. Hevelius mentions, in his "Selenographia," an eclipse of the moon which happened in August, 1647, when he was not able to distinguish the face of the moon even with a good telescope, although the sky was sufficiently clear for him to see stars of the fifth magnitude: but such cases are rare.

The duration of a lunar eclipse depends on the following circumstances:—1. On the largeness of the circle of the earth's shadow, whose diameter may be different at different times; the nearer the moon is to the earth, the larger is that portion of the earth's shadow through which she passes. 2. On the apparent diameter of the moon, which may be different, on account of her variable distance, as she moves in an elliptical orbit. 3. On the distance of the moon from her node at the moment of her being full, which will cause her to pass through a greater, or less, portion of the earth's shadow. Thus when the moon is at  $K$ , fig. 57, the eclipse will be of comparatively small duration; when at  $L$ , its duration will be much longer, but not so long as when she is at  $N$ , in the node, when she passes through the center of the shadow. 4. On the velocity of the moon's motion across the shadow of the earth, which is swiftest when she is in perigee, or nearest the earth,



and the duration of a central eclipse will then be shortest. According to these circumstances will be the time of continuance of a lunar eclipse. When the moon is centrally eclipsed, and when she is at her greatest distance from the earth, its duration is 3 hours, 57 minutes, 26 seconds, from beginning to end: and when she is at her least distance, 3 hours, 37 minutes, 26 seconds. The moon may be totally eclipsed, although she do not pass through the center of the shadow; but in this case the duration of the eclipse will be shorter than what has been now stated. In some instances, the continuation of total darkness may amount only to a few minutes, when the moon passes near the extremity of the shadow.

## SECTION II.

## ON ECLIPSES OF THE SUN.

AN eclipse of the sun is caused by the interposition of the body of the moon between the sun and the earth, when she throws a shadow over a certain portion of the earth. This can happen only at the time of new moon, and when the moon is at or near one of her nodes. The eclipses of the sun and moon, though expressed by the same word, are in their nature very different; the sun, in reality, loses nothing of his native luster in the greatest eclipse, but is all the while diffusing streams of light around him in every direction, and illuminating without intermission all the bodies in the planetary system. Some of these streams, however, are occasionally intercepted in their course toward the earth by the moon coming between the earth and sun, and at that time the dark side of the moon is turned toward the earth. When the moon is eclipsed, she suffers a real diminution of her borrowed light; but when the sun is said to be eclipsed, there is no diminution of his light, and it is in reality an eclipse of the earth by the shadow of the moon falling upon a certain portion of our globe: and this shadow would be distinctly seen, by an inhabitant of the moon, passing along a certain zone of the earth, like a small, dark, circular spot. The moon being much smaller than the earth, and having a conical shadow—because she is less than the sun—can cover only a small part of the earth by her shadow: hence an eclipse of the sun is visible only to a few inhabitants of the earth, whereas an eclipse of the moon is visible to all who are on that hemisphere, where the lunar orb is seen.

The following diagram, fig. 59, will convey a general idea of the nature of an eclipse of the sun. In this figure, *s* represents the sun; *m*, the moon; *e*, the earth; and *m x o*, the orbit of the moon. The moon is supposed to be in that part of its orbit next the sun, having the enlightened side toward the sun, and its dark hemisphere wholly turned toward the earth, which is its position at new moon. It is also supposed to be in its node, in an exact line between the sun and the earth. In this situation the shadow of the moon falls upon a certain portion of the earth, and intercepts the rays of the sun, for a little, from the inhabitants of the earth on whom the shadow falls. Part of the cone of the shadow is represented at *a b*, and it is never more than about 180 miles in diameter, within the limits of which the sun will appear totally eclipsed. But sometimes it happens that the extremity of the cone of the moon's shadow falls short of the earth, in which case an annular eclipse of the sun is produced; in which the sun appears like a brilliant ring of light around the

dark body of the moon. Beside the dark shadow, there is a penumbra or fainter shadow produced, which is represented at *c d*; and in all those parts where the penumbra falls, the sun will be only partially eclipsed. Thus, between *c* and *a*, the parts of the sun about *l v* cannot be seen; the rays coming from thence toward *c* or *a* being intercepted by the moon; but the portions of the sun about *g* and *h* will be visible. The nearer any place of the earth—within the penumbra—is to the dark shadow of the moon, the greater will the eclipse appear, and the nearer it is to the outside of the penumbra, the smaller will be that portion of the sun which is seen eclipsed. To those who live beyond the boundary of the penumbra, the whole disc of the sun will be seen and no eclipse will be visible. Hence it happens, that the sun may be totally eclipsed in Africa and the southern parts of Asia, and no trace of an eclipse perceived, at the same moment, either in Britain or America.

The following are some facts in relation to solar eclipses:—1. If the mean conjunction of the sun and moon takes place within 15 degrees of the moon's node, there must be an eclipse of the sun; but if the conjunction happen at a greater distance from the node than 21 degrees, there can be no eclipse. Therefore, between 15 degrees and

Fig. 59.

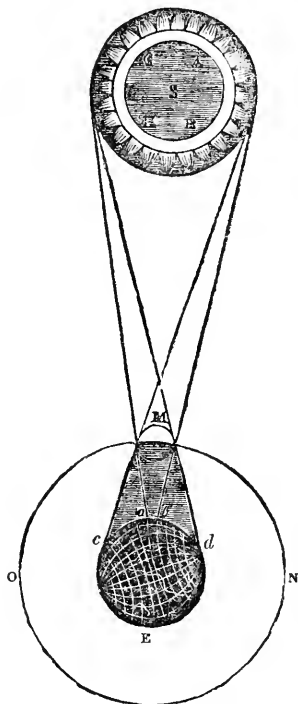

21 degrees there may or may not be an eclipse. 2. The penumbra covers a space of 4900 miles in diameter, within which the sun will appear more or less eclipsed. 3. The motion of the moon's shadow over the earth's surface is equal to her motion in her orbit, which is about 2200 miles in an hour; a velocity four times as great as that of a cannon ball. 4. The number of eclipses in any year cannot be less than two, and those both of

the sun; nor can they be ever more than seven: in which case there will be five of the sun, and two of the moon, and the moon's eclipses will be total. The usual number is four in a year, two at each node, and nearly half a year intervenes between the two sets of eclipses. 5. The sun is never totally eclipsed longer than about four minutes, but the moon may be immersed in the earth's shadow, or totally eclipsed, about 1 hour and 48 minutes. 6. Eclipses of the sun are more frequent than eclipses of the moon, because the ecliptic limits of the sun are greater; but we have more visible eclipses of the moon, because they are seen to the whole hemisphere next her; while eclipses of the sun only are visible from a very small portion of the earth's surface. 7. An eclipse of the sun begins on the western side, and ends on the eastern.

*Periods of Eclipses.*—It has been found that in 223 mean lunations, after the sun, moon, and nodes have been once in a line of conjunction, they return so nearly to the same state again, that the same node which was in conjunction with the sun and moon, at the beginning of the first of these lunations, will be within less than half a degree of a line of conjunction with the sun and moon again, when the last of these lunations is completed. Therefore, in that time there will be a regular period of eclipses for many ages. In this period there are 18 Julian years, 11 days, 7 hours, 42 minutes, 31 seconds; when the last day of February in leap years is four times included. Consequently, if to the mean time of any eclipse, either of the sun or moon, we add the above period, we shall have the mean time of the return of the same eclipse. During this period, there happen about 62 eclipses, 21 of the moon and 41 of the sun. If, then, we wish to know the mean time of an eclipse for any year, we have only to seek in old almanacs the exact time that any eclipse may have happened 18 years before, and add to such time the above mentioned period.

From what has been now stated respecting solar eclipses, it is evident that the darkness which accompanied our Saviour's crucifixion must have been supernatural. For it happened at the time of the Jewish passover; and that festival, by the appointment of the law, was to be celebrated at full moon, at which time it was impossible that the shadow of the moon could fall upon the earth, or the sun be eclipsed, according to the established laws of nature. Beside, in a total eclipse of the sun, the time of the continuance of total darkness is not more than about four minutes; but the darkness which overspread "the whole land" while our Redeemer hung upon the cross, continued without intermission for more than three hours. And again, although the sun had been totally eclipsed in a natural way, at that time, to the inhabitants of Jerusalem and its confines, it would have been only partially eclipsed to those who dwelt on the outskirts of the land of Judea; as the shadow of the moon, in an eclipse of the sun, covers only a small part of the earth's surface at one time. In confirmation of what has been now stated, it has been calculated by some astronomers, that an eclipse of the moon, which can only take place at the time of full moon, happened on the afternoon of that day on which our Saviour was crucified; so that, according to the language of the prophet, "The sun and the moon were both darkened in their habitation," at the time when this solemn and interesting event was accomplished.

Total eclipses of the sun have always been considered as remarkable events. Clavius remarks,

that at the total eclipse of the sun which happened in 1560, the darkness at Coimbra, in Portugal, was greater or at least more striking than that of the night, and that the birds fell to the earth through terror. At Berne, in Switzerland, on May 1, 1706, the sun was totally darkened for four minutes, during which time a fixed star and a planet appeared very bright. The sun's passing out of the eclipse was preceded by a blood red streak of light from his left limb, which continued about six or seven seconds; then part of the sun's disc appeared all on a sudden brighter than Venus was ever seen in the night,—and in that instant gave light and shadow to objects as strong as the moonlight generally does. One of the most minute accounts of the circumstances accompanying a total eclipse of the sun is that which is given by Dr. Stukely, of the eclipse which happened in 1724, in a letter to Dr. Halley; of which the following is an abridgment:—

"I chose for my station, Haradon-hill, near Amesbury, east from Stonehenge avenue. In front is that celebrated edifice upon which I knew that the eclipse would be directed. I had the advantage of a very extensive prospect in every direction, being on the loftiest hill in the neighborhood, and, that nearest to the center of the shadow. I had two men in company who looked through smoked glasses. The sky, though overcast, gave out some straggling rays of the sun that enabled us to see around us. It was half-past five by my watch when they informed me that the eclipse was begun. We watched its progress by the naked eye, as the clouds performed for us the service of colored glasses. At the moment when the sun was half obscured, a very evident circular rainbow formed at its circumference with perfect colors. As the darkness increased we saw the shepherds on all sides hastening to fold their flocks, for they expected a total eclipse of an hour and a quarter duration. When the sun assumed the appearance of the new moon, the sky was tolerably clear, but it was soon covered with deeper clouds. The rainbow then vanished; the hill grew very dark, and on each side the horizon exhibited a blue tint like that at the close of day. Scarcely had we time to count ten, when Salisbury spire, six miles to the south, was enveloped in darkness. The hill disappeared entirely, and the deepest night spread around us. We lost sight of the sun, whose place until then we had been able to distinguish in the clouds, but whose trace we could now no more discover than if it had never existed. It was now 35 minutes past six; shortly before the sky and the earth resumed a livid tint; there was also much black diffused through the clouds, so that the whole picture presented an awful aspect that seemed to announce the death of nature.

"We were now involved in a total and palpable darkness. It came on rapidly, but I watched so attentively that I could perceive its progress. It came upon us like a great dark mantle thrown over us. The horses we held by the bridle seemed deeply struck by it, and pressed closely to us with marks of extreme surprise. As well as I could perceive, the countenances of my friends wore a horrible aspect. It was not without an involuntary exclamation of wonder, I looked round me at this moment; I distinguished colors in the sun, but the earth had lost all its blue and was entirely black. A few rays shot through the clouds for a moment, but immediately afterward the earth and the sky appeared totally black. It was the most awful sight I had ever beheld in my life. Northwest of the point whence the eclipse came on, it

was impossible to distinguish in the least degree the earth from the sky, for a breadth of 60 degrees or more. We looked in vain for the town of Arnesbury, situate below us; scarcely could we see the ground under our feet. All the change I could perceive during the totality was that the horizon by degrees drew into two parts, light and dark; the northern hemisphere growing still longer, lighter, and broader, and two opposite dark parts uniting into one, and swallowing up the southern enlightened part.

"At length, upon the first lucid point appearing in the heavens where the sun was, I could distinguish pretty plainly a rim of light running alongside of us, a good while together, or sweeping by our elbows, from west to east; just then, having good reason to suppose the totality ended, I found it to be full three minutes and a half. The hill tops then resumed their natural color, and I saw no horizon at the point previously occupied by the shadow. My companions cried out that they again saw the steep hill toward which they had been looking attentively. Presently we heard the song of the larks hailing the return of light, after the profound and universal silence in which everything had been plunged. The heavens and the earth now appeared of a grayish cast, interspersed with blue, like the morning before sunrise. As soon as the sun appeared, the clouds grew denser, and for some minutes the light did not increase, as happens at a cloudy sunrise. The instant the eclipse became total, until the emersion of the sun, we saw Venus but no other stars. We perceived at this moment the spire of Salisbury Cathedral. The presence of the clouds added much to the solemnity of the spectacle, incomparably superior, in my opinion, to the eclipse of 1715, which I saw perfectly from the top of Boston steeple, when the sky was very clear. There, indeed, I saw the two sides of the shadow, coming from afar and passing to a great distance behind us; but this eclipse exhibited great variety, and was more awfully imposing. So deep an impression has this spectacle made on my mind, that I shall long be able to recount all the circumstances of it with as much precision as now."

There have been no total eclipses of the sun in Britain, since those of 1715 and 1724, nor will there be one visible here during the present century. The first total eclipse in England will happen on the 3d of February, 1916. The most remarkable solar eclipses for the next half century are those of March 15, 1858, and August 19, 1887. The last total eclipse of the sun visible in Europe, happened on July 8th, 1842, of which the following account is abridged from the *Athenæum*:

"Vienna, July 8, 1842.—The eclipse, the object of our journey to Vienna, was worth going any distance to see. No partial eclipse, however considerable, can give the faintest notion of what a total one is. All Vienna was in expectation for many days previous to the event, and strangers flocked to that capital in crowds to witness that phenomenon. The celebrated astronomer, Schumacher, came all the way from Denmark on purpose to see the eclipse with astronomical eyes. At four in the morning, I beheld the clear rays of the sun, shining opposite my window, while the general appearance of the sky indicated a favorable concurrence of circumstances. Soon after five, I was on my way to the Botanical Garden, and already the ramparts of the city were thronged with multitudes. About ten minutes before six the first spot of darkness was observed upon the sun. From that time until the total obscuration, there was no very unusual appearance. The sky, about

half an hour before the commencement of the eclipse, became somewhat obscured by vapor, and blue mists arose increasingly from the horizon. A perceptible chilliness crept into the air, and flights of swallows flew wildly and restlessly through the darkening atmosphere; but as long as the smallest portion of the sun was visible, there was considerable light. But now approached the important moment. A heavy bell tolled at intervals from the city, like the funeral knell of our beautiful orb of light and life, and the sharp shrill cries of the birds, which had disappeared, as if to take refuge from some impending convulsion of nature. Yet a moment, and on a sudden, an effect took place, unexpected and sublime. The whole aspect of heaven and earth underwent a change, with regard to light, coloring, everything: and the instant that preceded the total eclipse, resembled in nothing, and gave no idea of that which followed it.

"Round the black sun was an irregular halo of whitish light, defining clearly and strongly the obscured orb. In some places, this halo extended into longer gleams, forming altogether a faint glory. It was not so generally dark as I had supposed it would have been,—but the sudden diminution of light, at the moment of total obscuration, was sudden and startling. Also the sudden diminution of temperature, the thermometer falling 11 degrees instantaneously upon the complete immersion of the sun. One of the most striking and unexpected effects, was a red and lurid glow, that suddenly kindled upon the horizon; the blue pale vapor that had risen from the east, being converted into the semblance of a mighty conflagration. The principal light in the landscape came from thence, no longer from the sun. The rest of the atmosphere was of a sickly greenish tinge, overcast with duskiness, through whose spectral tints the crowds upon the ramparts were dimly discerned, all standing in solemn stillness, like the vast shadowy multitudes in one of Martin's pictures.

"The number of stars visible during this eclipse, at Perpignan, according to Arago, was only ten. The number was greater at Montpellier and Milan. Its effect upon animals was remarkable. One of the friends of Arago had five healthy hincts in a cage, three of which died during the sudden darkness of the eclipse. Oxen formed into a circle, with their horns thrust forward, as if to repel an enemy. At Montpellier bats and owls appeared, sheep lay as if for the night, and horses in the fields were in terror. M. Fraise a naturalist, relates that a swarm of ants, in full march, stopped short at the moment of occultation, when the darkness was nearly at its height."

The following table contains a statement of the principal solar eclipses during the present century:

In this table, the eclipses marked with an asterisk are calculated for the meridian of Paris; all the others are calculated for the middle of England.

Eclipses are not only striking and interesting phenomena of nature, but are of considerable advantage and utility. In the first place, from an eclipse of the moon we derive one conclusive argument to prove the globular figure of the earth, from the circular shape of the shadow of the earth in a lunar eclipse. 2. Eclipses of the moon prove that the sun is larger than the earth, because the shadow of the earth shortens in its breadth as it retires from the earth, and at length terminates in a point, which it could not do if the sun were smaller. 3. They also prove that the earth is larger than the moon, because the whole of the moon's body is sometimes involved in the

	Beginning of eclipse.			Middle of the eclipse.			End of the eclipse.			Dig. eclipsed.					
	h.	min.	sec.	h.	min.	sec.	h.	min.	sec.	deg. min.					
May 6, 1845	8	30	25	morn.	9	51	55	morn.	11	19	55	morn.	5	12	
April 25, 1846	5	42	0	even.	6	30	0	even.					3	42	
Oct. 9, 1847	6	22	38	morn.	7	36	38	morn.	8	48	38	morn.	11	0	
July 28, 1851	1	57	11	even.	3	5	11	even.	4	10	41	even.	9	43	
March 15, 1858	11	29	30	morn.	12	52	2	even.	2	12	0	even.	11	30	
July 18, 1860	1	34	30	even.	2	45	0	even.	3	52	30	even.	9	12	
Dec. 31, 1861*	2	5	0	even.	3	4	0	even.					6	13	
May 17, 1863*	6	0	0	even.	6	46	0	even.	7	30	0	even.	3	58	
Oct. 19, 1865	3	55	58	even.	5	9	58	even.	6	17	28	even.	7	36	
Oct. 8, 1866*	5	2	0	even.	Sun sets 5h. 32m.									3	58
March 6, 1867	8	7	26	morn.	9	21	26	morn.	10	40	26	morn.	8	42	
Feb. 23, 1868*	3	42	0	even.	3	54	0	even.	4	6	0	even.	0	9	
Dec. 22, 1870	11	15	28	morn.	12	32	58	even.	1	48	28	even.	9	36	
May 26, 1873*	7	56	0	morn.	8	48	0	morn.	9	34	0	morn.	3	36	
Oct. 10, 1874*	8	55	7	morn.	10	13	37	morn.	11	34	37	morn.	6	18	
Sept. 29, 1875*	11	56	0	morn.	12	37	0	even.	1	7	0	even.	2	7	
July 19, 1879*	7	45	0	morn.	8	39	0	morn.	9	41	0	even.	4	8	
Dec. 31, 1880*	1	49	0	even.	2	47	0	even.	3	36	0	even.	4	28	
May 17, 1882*	6	22	0	morn.	7	0	0	morn.	7	49	0	morn.	3	19	
Aug. 19, 1887	3	25	22	morn.	4	15	22	morn.	5	7	52	morn.	11	58	
June 17, 1890*	8	19	0	morn.	9	22	0	morn.	10	48	0	morn.	5	46	
May 28, 1900*	3	21	0	even.	4	30	0	even.	5	23	0	even.	7	53	
Aug. 30, 1905	11	54	52	morn.	1	8	42	even.	2	19	42	even.	9	30	
April 17, 1912	10	48	12	morn.	12	23	12	even.	1	45	12	even.	11	30	
Feb. 3, 1916	4	21	10	even.	5	21	40	even.	6	18	10	even.	12	0	

earth's shadow, and a section of this shadow at the moon is much less than the earth itself. 4. The longitude of places may be obtained by eclipses to a great degree of accuracy. An eclipse commencing at the same moment of time to all places at which it is visible, the difference in the observed time at any two places will give the difference of longitude between the places. 5. Eclipses have lent their aid in settling the precise date of ancient historical events. For if near the time of any memorable event recorded in history, a remarkable solar or lunar eclipse be also recorded, we may know whether the real time of this

event be rightly determined, by calculating backward, and ascertaining whether any remarkable eclipse happened near the period supposed. For example, Thucydides relates that a solar eclipse happened on a summer's day, in the afternoon, in the first year of the Peloponnesian war, which eclipse was so great that the stars appeared. This is stated in modern authors to have been in the year 413 before Christ, and by computation it appears that on the 3d of August in that year, there was a great solar eclipse, which passed over Athens about six o'clock in the afternoon; which therefore corroborates the decision of chronologers.

## CHAPTER VII.

### ON THE SEASONS, AND THE DIFFERENT LENGTHS OF DAYS AND NIGHTS

We formerly had occasion to state that the earth revolves round its axis every 24 hours, and round the sun in about 365 days and nearly 6 hours. These motions are intimately connected with the different lengths of days and nights, experienced in almost every region of the globe, and with the seasons which diversify the different portions of the year.

The constant succession of day and night—though so common as to be almost unheeded—is in reality a very wonderful operation of the Most High. When, after a dark and tempestuous night, the sun first appears in the unclouded horizon, all nature appears animated by his presence. The magnificent scene of creation, which a little before was involved in obscurity, opens gradually to view—and every object around has a tendency to excite sentiments of delight and adoration, if man were disposed to contemplate the works of his Creator with intelligence and pious emotion. The heavens are adorned with azure, the clouds

are tinged with the most lovely hues, the flowers expand their buds, and put forth their colors; the birds awake to melody, and the insect tribes are on their wing, all rejoicing in the light of the luminary of day. The curtain of darkness is likewise removed from the abodes of men, which are previously obscured, and we behold the cities, towns and villages, the lofty domes, the glittering spires, and the palaces and temples with which the landscape is adorned. After a night of darkness and tempest, such a scene appears almost like a new creation. The sun, after moving in all his brightness through the canopy of heaven is again hidden from our view in the western region of the sky, and we are then presented with a scene still more wonderful and sublime: the moon rises in unclouded majesty—the planets are beheld moving in their different courses, and an innumerable host of stars, spread over the whole concave of the firmament, diffuse their radiance from afar. Such a spectacle, during the silence

of the night, fills the contemplative mind with solemn thoughts, and with sentiments of wonder and delight, and has a tendency to raise the soul to a consideration of the Great First Cause, "by whom the heavens were made."

In the course of the annual revolution of the earth round the sun, the inhabitants of every country, and of every clime, experience, though at different times, all the variety of the seasons, and the different lengths of days and nights with which they are accompanied. Spring, summer, autumn, and winter, follow each other in constant succession, diversifying the scenery of nature, and distinguishing the different periods of the year. In the present constitution of the earth, and in the present state of man, this vicissitude of seasons is attended with manifold advantages both to the human race and to the other tribes of animated nature, and is necessary toward bringing to maturity the various productions of the earth. During one-half of the year, from March 21, to September 23, the regions of our globe within the north polar circle enjoy their summer, and part of their spring and autumn. At the north pole, the sun shines six months without intermission; and from 66½ degrees of north latitude, the inhabitants of these climes enjoy a length of day varying from 24 hours to six months;—the nearer the pole, the longer is the day. In Greenland and Davis' Straits, our whale fishers enjoy, during the greater part of the time they are employed in those regions, an almost uninterrupted day of three or four months in length. During the same time, the inhabitants of the antarctic circle around the southern pole, are altogether deprived of the sun, and shrouded in darkness, until the 23d of September; when he again appears on the verge of their horizon. These countries, within the polar circles, may be considered as having only two seasons—summer and winter. They have a summer of about four months, during which the days are very long and the heat considerable. The rest of the year may be considered as winter: for so rapid is the transition from heat to extreme cold, and from cold to heat, that spring and autumn are scarcely perceptible. It is only in temperate climates that four distinct seasons are particularly distinguished and enjoyed. In such climates, in spring, plants have time to shoot, and grow insensibly, without being destroyed by late frosts, or too much hastened by early heats. In summer, the heat gradually diminishes; so that the fruits of autumn have time to ripen by degrees, without being hurt by the winter colds. Throughout most of the European countries, particularly in Italy, and the south of France, these four seasons are distinctly perceptible. In the warmest countries too, as well as in the coldest, there may be said to be only two seasons, that materially differ from each other; as in the tropical climates, about the central parts of Africa, and the southern regions of Asia. In such countries, there is a dry and scorching season, during seven or eight months, until the rainy season commences, which continues generally four or five months; and this is the chief distinction between their summer and winter.

Every season of the year is characterized by its peculiar phenomena and effects. Spring is characterized as the season of the renovation of nature after the gloom and torpor of winter. At this period, animals and vegetables feel the influence of returning warmth, and prepare for the continuance and increase of their several species. The plants and flowers, which were hid in winter,

as soon as genial showers refresh the soil, emerge from the ground, and begin to display their beauties. As the sun rises higher and higher above the horizon at noon, and the heat increases, the larger vegetables, shrubs and trees, unfold their leaves, and the winged tribes begin to build their nests, and to "sing among the branches." The landscape begins to be adorned with a lively green, interspersed with flowers of various hues, and all nature appears in ceaseless activity. In this season, about the 21st of March, the sun crosses the equinoctial; when the days and nights are equal over all the globe, and the north polar regions, which were previously involved in darkness, now begin to feel the light and genial influence of the sun. The approach of spring and its progressive advances, fill the hearts of all, the mendicant as well as the monarch, with hope, and unmixed joy and satisfaction; for this season affords us a thousand new delights. It charms us with the beauty and perfume of flowers; the songs of the winged tribes; the length of the day rapidly advancing; and the preludes of approaching summer, and the pleasures of rural excursions.

Summer has generally been considered, on the whole, as the most delightful season of the year. Every object is then clothed in renovated beauty and gladness—the winter snows are completely melted from the hills; the trees are bursting with leaves; the flowers are painting themselves with every variety of color, and every thicket, and every hill ring with the modulations of various notes—everything in the animal and vegetable world now appears in a progressive state toward maturity, and the insect race seem animated with peculiar vigor and activity under the more direct influence of the sun. At this time (about the 21st of June), the sun rises highest in his meridian course, the heat increases, the day is at the longest, the night consists only of a few hours of twilight, and the rising sun is accompanied with peculiar sublimity and splendor. The fleecy clouds are painted with purple and vermilion, the mountain-tops are fringed with radiance, and every object on the face of nature displays its peculiar form and beauties. This season, too, is sometimes distinguished by excessive heats, which produce languor and inactivity, and sometimes the sky is covered with dark and lowering clouds, when, on a sudden, the forked lightnings flash, and the thunders roll in awful majesty along the sky, appalling the timorous mind and producing terror among the tribes of animated nature.

Autumn is the season when the fruits of the earth are brought to maturity, to supply the wants of man and beast. The silent and gradual progress of maturity is now completed, and the promise of spring fulfilled. The fields are covered with a golden harvest, the reapers in joyful groups are cutting down their sheaves, and the productions of the earth are gathered into the garner, to be stored up as provisions for the coming year. In every garden and orchard, delicious fruits of various hues are seen hanging on the branches, to gratify the eye, the palate, and the imagination, and presenting a specimen of the superabundance of Divine goodness in providing such a variety of comforts for the human family. "Oh that men would praise the Lord for his goodness, and for his wonderful works to the children of men."—For He crown'd the year with his goodness, his "paths drop fatness;—the little hills rejoice on every side. The pastures are clothed with flocks; the valleys also are

covered over with corn; they shout for joy, they also sing." Toward the close of this season, the objects of the vegetable creation begin to lose their bloom and their beauty. The groves lose their leafy honours; the gaudy flowers disappear; and nature puts on a more bleak and somber aspect. But before the forests and the groves are stripped of their beauty, they assume a temporary splendor superior to even the verdure of spring, or the luxuriance of summer. The ever-changing hues of the leaves of the trees, melting into every soft gradation of color and shade, have long engaged the imitation of the painter, and in some measure enliven the gloom of the falling year. During this season (on the 23d of September), the sun crosses the equinoctial, in his course toward the south. He then sets to the north pole, and begins to diffuse his rays on the south polar regions, where spring now commences; and during all the period which intervenes from this time, until the 21st of the following March, the sun shines without intermission around the southern pole.

Winter succeeds autumn, and completes the circle of the seasons, in our northern latitude. The thickening fogs, the heavy rains, the hail showers, and the descending snows, now begin to deface the beauties of the rural landscape. The melody of birds is seldom heard in the groves; the flowers lie dead, and their beauties defaced; the trees are lashed by storms, stripped of their verdure, and spread their naked arms to the ruthless winds. The vapors sometimes thicken into an impenetrable gloom, and obscure the face of the sky. The rains descend in torrents; the brooks swell, the rivers burst their banks, and bury the meadows under a soaking deluge. The atmosphere is now and then hurled into tumultuous confusion, and everything trembles before the furious blast. The trees of the forest are dashed headlong to the ground, and the shepherd's cot carried aloft in the air, or shattered in pieces. The ocean swells with violent commotions, and tosses its waves toward the clouds. Ships are dragged from their anchors, and are whirled about as stubble along the vast abyss, and some of them plunged into the open gulf, with all their mariners, to rise no more. Such are some of the aspects and desolations of stern winter. But it is also accompanied with numerous benefits to mankind. The frost and cold which winter produces, prevent many hurtful vapors in the higher regions of the atmosphere from falling upon us, and purify the air from noxious exhalations. Far from being prejudicial to health, they often improve it, and prevent the humors from that putrefaction which heat might produce. Cold has a tendency to brace the animal system, and to promote the circulation of the blood. When the fields and gardens are covered with snow, this is necessary to preserve them from the cold, and to prevent the grain from corrupting. The earth requires repose, after having yielded in summer all that we require for our subsistence during the winter. While the cold continues, the means are at hand for procuring artificial heat, by the abundance of coals and wood which the Creator has provided. During this season, too, we enjoy the most brilliant and interesting views of the starry heavens, of the planets in their courses, and of the moon "walking in brightness." So that in every season, we have abundant evidence of the goodness of our bountiful Creator, and of the tender care he exercises over every portion of the human family. During the middle of winter the

days are shortest and the nights the longest. This happens more particularly about the 21st of December, when the sun, in our latitude, rises near the south-east, describes a short curve a little above the southern horizon, and sets near the south-west, after having remained only seven or eight hours above the horizon.

It is here worthy of remark, that all the diversified phenomena of the seasons, and the different lengths of days and nights throughout the year, are produced by the operation of a few apparently simple principles. In all the operations of the Almighty, we find that the most diversified and astonishing effects are produced by causes that are either unheeded, or by agents which, to our limited view, appear altogether inadequate to produce the results. From the simple principle of gravitation, for example, proceed all the beauties and sublimities which arise from the meandering rills, the majestic rivers, and the roaring cataracts; it causes the mountains to rest on a solid basis, and confines the ocean to its appointed channels; it produces the descent of the rains, and dews, and the alternate flux and reflux of the tides; it rolls the moon round the earth, and prevents her from flying off to the distant regions of space; it extends its influence from the earth to the moon, and from the sun to the remotest planets—preserving surrounding worlds in their proper courses, and connecting the solar system with other worlds and systems in the remote spaces of the universe. From the minutest atom to the vast luminaries of heaven, everything is subject to its all-powerful influence; and from this active invisible agent proceed all the order, beauty, and variety, which distinguish the works of creation. Thus, also, the principle called electricity—which manifests itself in sparks of fire, when a glass tube is rubbed in the dark—is found to be the cause which produces the lightnings of heaven, and all the sublime phenomena which accompany a violent thunderstorm; and, in combination with other agents, produces likewise the fiery meteor which sweeps through the sky with its luminous train, and the beautiful coruscations of the aurora borealis.

In like manner the vicissitude of day and night and the revolution of the seasons and their diversified phenomena, depend on the most simple principles and arrangements. The alternate succession of day and night is occasioned merely by the uniform rotation of the earth upon its axis. As our globe turns round on this imaginary line every 24 hours, and as only one-half of a globe can be illuminated at a time, it is evident that any particular place will sometimes be turned toward the sun, and sometimes opposite to it: and being thus constantly subjected to these various positions, a regular return of light and darkness will be experienced during the above period in every region not within the limits of the polar circles. When, by the diurnal revolution, any place is carried into the dark hemisphere, it is night; and when turned round into the enlightened hemisphere, it is day. The sun and all the other heavenly bodies appear to move along the heavens every day from east to west; but this motion is only apparent, and is caused by the real motion of the earth on its axis from west to east; but the apparent motion of these bodies is somewhat different at different seasons of the year, and in different regions of the globe. (See ante, p. 11.) All the planets on whose surfaces spots have been discovered, are likewise found to perform rotations round their axes, which will produce a similar revolution of day and night, as in our world, though in different periods of

time, some of the planets finishing the periods of their rotation in about ten hours, some in ten and a half, and others in twenty-three hours.

As to the vicissitudes of the seasons—this is owing to the inclination of the earth's axis to the plane of its orbit. If the axis of the earth stood perpendicular to the plane of its orbit, there would be no variety in the length of days and nights; but they would of course be equal all over the globe, except at the poles, where the sun would neither rise nor set, but remain continually in the horizon, as he is seen at present in that position on the 21st of March and the 23d of September, at the north and south poles. This inclination is  $23\frac{1}{2}$  degrees from the perpendicular, which makes an angle with the earth's orbit, or the ecliptic, of  $66\frac{1}{2}$  degrees. The axis of the earth always keeps parallel to itself, in its motion round the sun, and points exactly to the same part of the heavens. This may appear somewhat strange, since the orbit of the earth is 190 millions of miles in diameter; but this extent, however great, is only as a point when compared with the immense distance of the fixed stars—the nearest of which is at least more than two hundred thousand times farther from us than we are from the sun. If we look along two parallel rods, four or five yards distant from each other, they will both seem to point directly to the moon when in the horizon, though at such a distance from each other, although they would not both point to the same object placed at a short distance. And perhaps four or five yards bear as great a proportion to the distance of the moon as 190 millions of miles bear to the distance of the stars.

The subject of the seasons may be illustrated by the following diagram, fig. 60, which repre-

sents the earth in four different positions in its orbit, the central figure representing the sun. It is known from observation that the axis of the earth is always directed to very nearly the same fixed point in the heavens, and therefore it will constantly preserve the same position, in whatever part of its orbit the earth may happen to be in its circuit round the sun, as may be seen in the figures here represented. Let us now suppose the earth to be in the situation represented at March, or at *s*, at the higher part of the diagram. A right line joining the centers of the earth and sun will cut the surface of the earth in the equator, and the boundary between light and darkness will pass through the two poles, and the days and nights will consequently be equal throughout the whole earth, except at the poles, which are in the boundary of light and darkness. But when the earth, in its annual course, is carried along the fourth part of its orbit to its position, as represented in June, toward the left hand of the figure, the north pole of the axis still continuing to point in the same direction, will advance into the enlightened hemisphere, and will be  $23\frac{1}{2}$  degrees and a half from the boundary between light and darkness, and the south pole at the same distance within the dark hemisphere. It is evident that, in this position, the earth may turn round its axis a considerable number of times, and yet no place around the poles be within the boundary of darkness. And if the earth were to continue in this part of its orbit, the sun would never set to the inhabitants near the north pole, nor rise to those near the south. At the equator it would be always equal day and night; and in all places north of the equator their days would be longer and their nights shorter in proportion to their

Fig. 60.

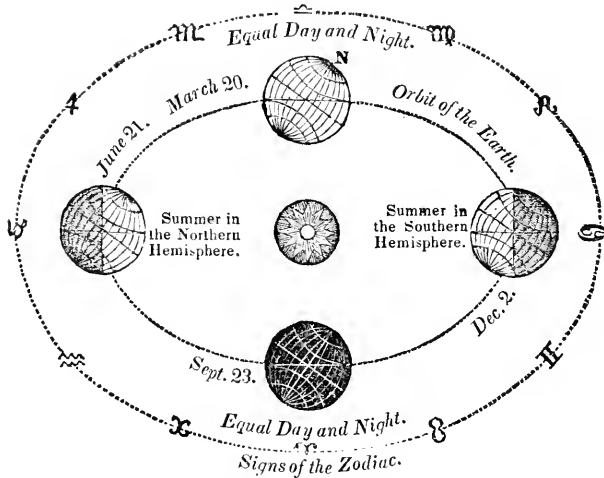

nearness to the arctic or north polar circle, while those on the south side of the equator would have their nights longer than their days.

But as the earth moves forward in its orbit toward September, represented in the lower part of the cut, the north pole will gradually approach the boundary between light and darkness, which boundary will again pass through both poles on the 23d of September; the days will gradually shorten until it arrive at this point, and day and night over the globe will be then equal as before. This is called the autumnal equinox, and this sea-

son is a kind of medium between summer and winter. As the earth proceeds through the other quarter of its orbit, the days will still shorten until December 21st: when the north pole of the earth will be just as far in the dark hemisphere, as it was in the enlightened one on the 21st of June. This position of the earth, represented at the right-hand side of the cut, is called the winter solstice. From this period to the vernal equinox in March, the days gradually lengthen as the north pole again approaches the boundary between light and darkness; and when the earth arrives at that

point, the circle of the year and of the seasons is completed. From the description now given it will evidently appear that the inhabitants of the southern regions of our globe have the same variety of seasons which we enjoy, but in a reverse order. When it is summer in southern climes, it is winter with us; and when it is spring with us, it is autumn in the southern regions.

The different signs of the zodiac through which the earth, or the sun, passes in the course of the annual revolution are depicted in their several characters, in the outer circle of the diagram. They are as follows:—beginning at the bottom, at September, and proceeding toward the right hand, Aries, Taurus, Gemini, Cancer, Leo, Virgo, Libra, Scorpio, Sagittarius, Capricornus, Aquarius, Pisces. These are the names of the twelve constellations through which the sun apparently passes in the course of a year. In March, the real place of the earth is Libra, and consequently the sun will appear in the opposite sign in Aries, and be vertical to the equator. In June, the earth is in Capricorn and the sun in Cancer, when he is vertical to those who live under the tropic of Cancer. In September, the earth is in Aries and the sun in Libra, when he is again vertical to the equator. In December, the earth is in Cancer and the sun in Capricorn, when he is vertical to those living under the tropic of Capricorn; as the inhabitants of South Africa and the central parts of New Holland. The explanations now given of the seasons would, perhaps, appear more perspicuous to the astronomical tyro, were they to be illustrated by an orrery, a tellurion, or any other instrument calculated to elucidate the subject.

In the northern part of the globe, where we reside, our summer is nearly eight days longer than our winter. By summer, we understand the time which elapses between the 21st of March and the 23d of September; and by winter, the time between the 23d of September and the 21st of March; or the period between the autumnal and vernal equinoxes. In the former case the earth passes through 134 degrees of its orbit, which occupies 186 days, 11 hours; in the latter case it passes through only 176 degrees, which is performed in 178 days, 18 hours. The reason of this difference is, that the earth moves in an elliptical orbit, one portion of which is nearer the sun than another; in consequence of which the sun's apparent motion is slower when in the northern signs than while it traverses the southern ones. This orbit is more than three millions of miles longer in one direction than it is in another; consequently, the sun is farther from us at one season than he is at another. On the 1st of January he is three millions of miles nearer us than on the 1st of July, which is ascertained from the difference of his apparent diameter at those seasons. On the 1st of January his apparent diameter is 32 minutes, 35 seconds, whereas, on the 1st of July, he is only 31 minutes, 31 seconds,—being a difference of 1 minute of a degree and 4 seconds.

Here a question will naturally occur,—Why have we the coldest weather when the sun is nearest us, and the hottest when he is farthest distant? This is owing to various causes; the principal of which is, that the sun's rays in winter fall so obliquely upon us, and have so large a portion of the atmosphere to pass through, that they come with less force, and spread over a larger space than they do in the summer, when the sun is at a greater height above the horizon. Beside, in the long nights of winter, we have a greater degree of cold than can be compensated

by the return of heat in the short days, by reason of which the cold will be increased until the days sensibly lengthen. On the other hand, the greater length of the day contributes to augment the heat in summer; for the earth and air are heated by the sun in the day-time more than they can be cooled in the night, and on this account the heat will go on increasing in summer, until the days sensibly decline. In summer, too, the sun rises to a high altitude, and his rays pass through a much less portion of the atmosphere, and are less refracted and weakened by it than when they fall more obliquely on the earth, and pass through the dense vapors near the horizon. Hence it is, that it is colder near the time of sunset, and a little after sunrise, than when the sun is near his meridian altitude. It is owing to these and similar circumstances that the hottest and coldest seasons of the year are not about the time of the longest and shortest days, but generally about a month after these periods. For a body once heated does not grow cold instantaneously, but gradually; and so long as more heat comes from the sun in the day than is lost in the night, the heat will gradually increase until it comes to a certain maximum, when the increasing length of the night will cause it to diminish.

The subject of the seasons has been a favorite theme to poets as well as to philosophers; and they have frequently expatiated on the beauties and the beneficent designs connected with the varying aspects of the revolving year. And it must be admitted that, in the present constitution of our globe, and in the present moral state of the human race, there are many advantages enjoyed, and much of the Divine goodness is displayed in every one of the seasons as they successively appear, which brings along with it its peculiar beauties, pleasures, and enjoyments. But the earth, with the seasons as they now "roll," can scarcely be considered as an abode suited to an innocent creature that has retained its original purity and integrity;—the burning heats in summer, which are felt in the southern climes, the whirlwinds, tornadoes, inundations, thunders and lightnings, with which they are frequently accompanied; and the frosts and snows, storms and tempests, and insufferable cold which are felt in winter in different parts of the temperate climates, and in the polar regions—seem to be accommodated only to beings who are involved in guilt and tainted with moral depravity; and, therefore, we have no reason to believe that the seasons, as they now exist, would have presented the same aspects, or operated in the same manner, had man remained in his primeval innocence and allegiance to his Maker. A great change seems to have taken place in this and other respects at the period of the universal deluge, when the "fountains of the great deep" were broken up, the cataracts of heaven opened, and the solid strata of the earth scattered and disrupted; then, in all probability, the constitution of the atmosphere likewise underwent an extensive change as to its composition and properties, which is partly the cause of some of those storms and tempests and other phenomena which arise in the course of the revolution of the seasons. But, even in the present state of nature, we have reason to be grateful to God, that in all his dispensations toward his creatures "he remembers for us mercy in the midst of deserved judgment"—that while hurricanes, tempests, and earthquakes sometimes produce dreadful devastations, and sweep away multitudes of human beings from the living world, "his tender mercies" ray



be said, on the whole, to be diffused "over all his works;" for every season of the year brings along with it its own peculiar enjoyments, in a thousand different ways; and man, even in his present condition, might be a comparatively happy being, were his thoughts and affections, his temper and actions, regulated by the principles and precepts of Christianity and the moral laws of his Creator. The evil passions and depraved affections which prevail among mankind, are far more destructive to human happiness than all the storms and tempests, thunders and lightnings, earthquakes and volcanoes, that rage throughout the seasons and convulse the elements of nature.

The present state of man on earth, in the midst of the circling seasons, appears to be adapted only to a being who has but a short time to remain in this terrestrial sphere; whose aim ought to be to aspire after a nobler scene of existence—to enter in the prescribed path to this happier state, by believing in the name of the only begotten Son of God, who is "the Way, the Truth, and the Life"—and by cultivating, with vigilance and caution, those heavenly tempers and Divine virtues which will prepare him for the employments of an immortal existence. As the engagements of life and religion are such as human nature does not always willingly perform, and is apt to postpone them to what it considers a more convenient season—the vicissitudes of the seasons, and other arrangements in nature, have a tendency to stimulate us in the performance of present duty. Whatever we behold in the economy of nature around us, reminds us of the lapse of time and the flux of mortal existence. The day and night regularly succeed each other, and remind us that a certain portion of duration has fled. The sun appears in the eastern horizon; he soon attains his meridian altitude, then declines, and in a few hours sets in the west;—the stars in their courses mark the lapse of our fleeting moments;—the moon does the same every night, by changing its form; and the revolution of the seasons diversifies the year, and shows how large a portion of human life glides silently away. If the wheel of life passed on in undistinguishable uniformity, we should scarcely be able to mark its approach to the end of the course. If one hour were uniformly like another—if the diurnal motion of the

sun did not show that another day is on the wing—if the circling seasons did not impress us with the flight of another year—quantities of duration, equal to days, months, and years, might glide away without being observed, and without improvement. But the course of time, marked out by so many movements, objects and circumstances, continually reminds us of what progress we have made in gliding down the stream of life toward the ocean of eternity! and admonishes each of us by its rapidity "Whatsoever thy hand findeth to do, do it with thy might," since the day rolls on, and "the night cometh, when no man can work."

In fine, the several divisions of the seasons have been considered as bearing a striking analogy to the course of human existence. Spring has been represented as the youth of the year, the season of pleasing hope, blooming beauty, and lovely energy. Summer has been likened to perfect manhood, the season of confirmed strength, and persevering vigor. Autumn has been compared to that period when man is mellowed by age and brings forth the fruits of wisdom and experience. And cheerless Winter has been termed the decrepit and hoary old age of the year. If a day be considered as an image of a year, and the year as a representation of human life—then the morning answers to spring, and the spring to childhood and youth; the noon corresponds to summer, and the summer to manhood. The evening is an emblem of autumn, an autumn of declining life; the night is an emblem of winter, in which the powers of vegetation are benumbed,—and winter points out the time when life shall cease, with all its hopes and joys. With such views, Thomson, the poet of the "Seasons," closes his description of Winter:

Behold, fond man!  
See here thy pictured life: pass some few years,  
Thy flowering Spring, thy Summer's ardent strength,  
Thy sober Autumn fading into age,  
And pale concluding Winter comes at last,  
And shuts the scene. Ah! whither now are fled  
Those dreams of greatness? those unsolid hopes  
Of happiness? those longings after fame?  
Those restless cares, those busy bustling days?  
Those gay-spent festive nights? those veering thoughts  
Lost between good and ill that shared thy life?  
All now are vanished! Religion sole survives,  
Immortal, never-failing friend of man,  
His guide to happiness on high!

## CHAPTER VIII.

### REFLECTIONS, MORAL AND RELIGIOUS, IN REFERENCE TO THE SOLAR SYSTEM.

WITHOUT entering at present on the consideration of any other topics connected with astronomical science, we shall conclude the present work with a few reflections, suggested by the subject we have endeavored to illustrate in the preceding pages.

The science of astronomy presents to our view objects which are calculated to raise our admiration, and to excite the soul to solemn reflection, and elevated contemplations. When we take but a cursory view of the nocturnal heavens, in a clear and serene evening, we are almost irresistibly overpowered with emotions of wonder and awe, at the amazing grandeur of the vast canopy around us, and the number of the brilliant orbs which shed their radiance upon us from afar!

But when, with the eye of the intellect, assisted by the telescope and the discoveries of science, we endeavor to traverse the immense spaces above us, and to survey the number, the magnitude, the distances, and the rapid motions of the globes dispersed throughout the regions of immensity, we are completely overpowered, and lost in astonishment, at the extent and grandeur of the scene—their numbers cannot be told; their magnitude cannot be conceived; their distances are beyond human calculation and comprehension; and the amazing velocity with which they fly through the regions of space is confounding and almost terrifying to the imagination. Millions upon millions of those magnificent globes have been running their ample rounds for thou-

sands of years, and will, doubtless continue their courses, though amidst numerous changes, throughout all the revolutions of eternity. The immense forces with which they are impelled in their career; the magnificent circles they describe; the beautiful order in which they are arranged; the regularity and harmony of their movements; and the noble and important ends to which they are destined, proclaim, in language not to be mistaken, that "the hand that made them is Divine;" and, therefore, that they ought to be studied, and contemplated with pious emotion, by every rational and religious mind:

"Come forth, O man! yon azure round survey,  
And view those lamps which yield eternal day.  
Bring forth thy glasses; clear thy wondering eyes;  
Millions beyond the former millions rise;  
Look further;—millions more blaze from yonder skies."

Who can look up to the midnight sky, and behold its rolling wonders, without being struck with astonishment at the idea of that great Being, who formed such vast and magnificent works? "Canst thou by searching find out God? canst thou find out the Almighty unto perfection?" There is a length and a breadth, a height and a depth, in the perfections of the Divinity, which finite intelligences will never be able fully to comprehend. Vast and magnificent as the structure of the starry heavens is, it was produced without materials—it emerged out of nothing. The voice of the Eternal "spoke, and it was done." "He commanded," and the orbs of the firmament started into being. "Let there be light: and there was light." "By the word of the Lord were the heavens made; and all the host of them by the breath of his mouth." Our admiration of such wonderful works should lead us to humble ourselves in his august presence, and to reverence and adore him as the uncreated source of all felicity. "Let all the earth fear the Lord; let all the inhabitants of the world stand in awe of him."

But as we have not yet taken a survey of the starry heavens, and the wonderful scenes which they disclose, we shall chiefly confine our present reflections to the objects connected with the planetary system, of which we have given a brief sketch in the preceding pages.

In the first place, when we contemplate the grand machinery of the solar system, we are presented with a striking display of the Almighty power of Him who formed it. It presents to our view objects of overpowering magnitude and grandeur—planetary globes, a thousand times larger than the earth; and magnificent rings, which would reach nearly from the earth to the moon, and which would enclose within their vast circumference four hundred worlds as large as that on which we dwell. It exhibits a sun more than twelve hundred thousand times larger than our earthly ball, and five hundred times larger than all the planets, their satellites and rings, taken together, even although hundreds of comets were also included; and this sun extending its influence to bodies a thousand millions of miles distant, enlightening them by his beams, and retaining them in their orbits by his attractive influence. It presents before us motions, so astonishing as to overpower all our faculties—bodies, a thousand times larger than our globe, flying with a velocity of thirty thousand miles every hour, carrying along with them a retinue of revolving worlds, and continuing their rapid career, without a moment's intermission, for thousands of years—nay, motions at the rate of eight hundred thousand miles an hour have been perceived among some of the bodies connected with the solar system.

What a striking display do such objects present of the power and grandeur of Omnipotence, so frequently celebrated by the inspired writers. "Great is our Lord, and of great power: his understanding is infinite; his greatness is unsearchable;" wonderful works doth He, which we cannot comprehend. "Who is a strong Lord like unto thee? Who in heaven can be compared unto the Lord? Who among the sons of the mighty can be likened unto the Lord?" We are sometimes apt to be dazzled with the splendor of riches, and to admire, in the palaces of the great, the magnificence of the furniture, the beauty of the apartments, and the profusion of gold and silver ornaments that appears on every side. We are apt to reverence mighty potentates, when they bear rule over multitudes of subjects, and exercise their sway over extensive countries. We judge of the greatness of men by their actions, when they build spacious cities, and erect splendid palaces and temples; when they construct steam-engines and carriages, and impel them forward with a motion of fifty miles an hour. But, what are all the powers and energies of man, as displayed in his noblest achievements, compared with the magnificence and energies displayed throughout the planetary system? What are a few cities, palaces, and temples, compared with the grandeur and extent of mighty worlds? What is a small corner of the earth, compared with the expansive range over which the sun extends his influence? What is the motion of a small engine, even at fifty miles an hour, compared with the motion of a globe ten thousand miles in circumference, flying at the rate of a hundred thousand miles an hour? All human art, power, and grandeur must hide their diminished heads in the presence of Him who is the former and governor of spacious worlds. As the splendor of the stars is absorbed by the rays of the sun, so all the grandeur, power, and splendor of this world and its inhabitants vanish before the presence of Him who is "the King Eternal, Immortal, and Invisible," and before whom "all nations are accounted as nothing, and less than nothing and vanity." And, if such power is displayed in one sun, and one system of revolving worlds, how great beyond conception the effects of that Almighty energy which has brought into existence thousands and millions of other suns and systems, and dispersed them in countless numbers throughout the illimitable tracts of space! "Who can utter the mighty acts of the Lord?"—"Great and marvelous are thy works, Lord God Almighty!"

This attribute of the Almighty, so conspicuously displayed in the heavens, lays a sure foundation for the faith and hope and comfort of the Christian, amidst all the perplexities and afflictions to which he is subjected in the present state. For it assures him that whatever Jehovah has promised, "he is able also to perform." The promises addressed to us by a wise and benevolent Being can excite in us hope and dependence, only in so far as we are convinced of his power to secure their accomplishment. If omnipotence were not an attribute of the Divine Being, or were we unable to trace its operations in existing facts, we could have no rational dependence on his promises and declarations in regard to objects which are unseen and eternal, and which lie beyond the limits of human comprehension. But when we behold, in the arrangements of this lower world, and in the solar system, a display of omnipotent energy in incessant operation, far beyond the grasp of our limited faculties, we plainly perceive that there is not a promise recorded in Divine

revelation, nor a future fact declared, but is within the power of Jehovah fitly to accomplish and realize. "He doeth according to his will in the army of heaven, and among the inhabitants of the earth: and none can stay his hand, or say unto him, What doest thou?" Should afflictions assail us, he is able to comfort and support. Should calamities befall us, or dangers surround us, he is able to deliver. Should death stare us in the face, and heart and flesh begin to faint and fail, he is able to transport our spirits to a nobler scene of existence, and to re-animate our mortal frames at the resurrection of the just. Happy, then, is the man who hath this eternal God for his refuge, "whose hope is in the Lord his God: which made heaven and earth, the sea, and all that therein is: which keepeth truth forever." For He "is able to do exceeding abundantly above all that we can ask or think," "according to the working of his mighty power, which he wrought in Christ, when he raised him from the dead, and set him at his own right hand in the heavenly place."

2. The arrangements of the solar system display the wisdom and benevolence of its Creator. Were it possible to conceive a being possessed of such power as the planetary system displays, but devoid of wisdom and goodness, such a being would be the most terrible object which the human mind could contemplate. Power acting at random, without regard to the happiness of intellectual beings, could only produce terror and apprehension throughout the intelligent universe, uncertain whether or not its energies might be exerted for the purpose of promoting misery and destruction. But the attribute of omnipotence, when conjoined with infinite wisdom and boundless benevolence, conveys an idea the most glorious and transporting; and these perfections are conspicuously displayed throughout all the works of God. His wisdom is illustriously displayed in the arrangements of the planetary system, in placing near the center of this system that immense luminary, the sun, from whence light and heat might be distributed in due proportions to all the worlds that roll around it—in nicely proportionating the motions and distances of all the planets, primary and secondary—in uniting them in one harmonious system by one grand and universal law, which prevents them from flying off in wild confusion through the infinity of space—in nicely adjusting the projectile velocity to the sun's attractive power, so as to produce harmony of motion, and to prevent the planets, on the one hand, from rushing forward to the sun, and on the other, from flying off in a tangent through the regions of immensity—in the constancy and regularity of their motions, no one interfering with another or deviating from the course prescribed—in the exactness with which they run their destined rounds, finishing their circuits with so much accuracy as not to deviate from their periods of revolution the space of a minute in a hundred years—in the spherical figure given to all these mighty orbs, and the diurnal motions impressed upon them, by which a due proportion of light and heat is diffused over every part of their surfaces—and in the wonderful simplicity of the physical laws, on which so much beauty, harmony, and order depend. In all these and many other respects, the planetary system presents a display of "the manifold wisdom of God."

The benevolence of the Deity is likewise manifested throughout this system, in ordering all the movements and arrangements of the planetary globes, so as to act in subserviency to the comfort and happiness of sentient and intelligent beings.

For the wisdom of God is never employed in devising means without an end: and the grand end of all his arrangements, so far as our views extend, is the communication of happiness; and it would be inconsistent with the wisdom and other perfections of God not to admit that the same end is kept in view in every part of his dominions, however far removed from the sphere of our observation. We cannot, indeed, explore the minute displays of Divine goodness in the distant regions of the planetary system, but we perceive certain general arrangements which clearly indicate that the happiness of intellectual natures is one of the grand ends of the Divine administration. For example—light is essential to the comfort and happiness of all living beings. Its rays illumine the vast expanse of the heavens, and unvail all the beauties and sublimities of creation around us. Without its influence the universe would be transformed into a desert, and happiness, even in the lowest degree, could scarcely be enjoyed by any sentient or perceptive existence. Now we find, in the arrangements of the solar system, that ample provision has been made for diffusing light in all its varieties over every planet and satellite belonging to this system. All the planets revolve round their axes, in order that every part of their surfaces may enjoy a due proportion of the solar rays: around the more distant planets, an assemblage of moons has been arranged to throw light upon their surfaces in the absence of the sun. And while the satellites perform this office, the primary planets reflect a still greater quantity of light upon the surface of the satellites: and one of these planets is invested with a splendid double ring, of vast dimensions, to reflect the solar rays during night both on the surface of the planet and on the surface of its moons; all which arrangements must necessarily have a respect to the enjoyment of intellectual natures: otherwise they would be means without an end, which would be inconsistent with the wisdom and intelligence of the Deity. If, then, the happiness of various orders of intelligent beings was intended to be promoted by such adaptations and arrangements, we have here presented to our view a most glorious display of the expansive benevolence of that almighty Being who "is good to all," and whose "tender mercies are diffused over all his works." If this earth on which we dwell "is full of the goodness of the Lord," if countless myriads of living beings, from man downward to the minutest insect, are supported and nourished by the Divine bounty, how wide and expansive must be the emanations of that beneficence which extends its regards to worlds a thousand times more extensive and populous than ours! The benevolence of the Deity may be said to constitute his whole moral character, and to reflect a radiance on all his other perfections. Hence, in the records of inspiration, the Divinity is summarily described by this perfection alone, "God is love!" He is the uncreated source of all the happiness enjoyed by every rank of spiritual and perceptive existence, from the highest angel to the worm. "O give thanks unto the Lord; for he is good: for his mercy endureth forever."

3. The survey we have taken of the solar system has a tendency to moderate the pride of man and to promote humility. Pride is one of the distinguishing characteristics of puny man, and has been one of the chief causes of all the contentions, wars, devastations, systems of slavery, and ambitious projects which have desolated and demoralized our sinful world. Yet there is no disposition more incongruous to the character and

circumstances of man. Perhaps there are no rational beings throughout the universe among whom pride would appear more unseemly, or incompatible than in man, considering the situation in which he is placed. He is exposed to numerous degradations and calamities, to the rage of storms and tempests, the devastations of earthquakes and volcanoes, the fury of whirlwinds, and the tempestuous billows of the ocean, to the ravages of the sword, famine, pestilence, and numerous diseases; and at length he must sink into the grave, and his body must become the companion of worms! The most dignified and haughty of the sons of men are liable to these and similar degradations, as well as the meanest of the human family. Yet, in such circumstances, man—that puny worm of the dust, whose knowledge is so limited, and whose follies are so numerous and glaring—has the effrontery to strut in all the houghtiness of pride, and to glory in his shame.

When other arguments and motives produce little effect on certain minds, no considerations seem likely to have a more powerful tendency to counteract this deplorable propensity in human beings, than those which are borrowed from the objects connected with astronomy. They show us what an insignificant being—what a mere atom, indeed, man appears amidst the immensity of creation! Though he is an object of the paternal care and mercy of the Most High, yet he is but as a grain of sand to the whole earth, when compared to the countless myriads of beings that people the amplitudes of creation. What is the whole of this globe on which we dwell compared with the solar system, which contains a mass of matter so many millions of times greater? What is it in comparison with the hundred millions of suns and worlds which, by the telescope, have been descried throughout the starry regions? What, then, is a kingdom, a province, or a baronial territory, of which we are as proud as if we were the lords of the universe, and for which we engage in so much devastation and carnage? What are they, when set in competition with the glories of the sky? Could we take our station on the lofty pinnacles of heaven and look on this scarcely distinguishable speck of earth, we should be ready to exclaim with Seneca, “Is it to this little spot that the great designs and vast desires of men are confined? Is it for this there is so much disturbance of nations, so much carnage, and so many ruinous wars? Oh folly of deceived men, to imagine great kingdoms in the compass of an atom, to raise armies to decide a point of earth with the sword!” Soon may the time arrive when the prophecy shall be fulfilled:—

“The wolf shall dwell with the lamb,  
And the leopard shall lie down with the kid;  
And the calf and the young lion and the fating together;  
And a little child shall lead them.  
And the cow and the bear shall feed;  
Their young ones shall lie down together:  
And the lion shall eat straw like the ox.  
And the sucking child shall play on the hole of the asp,  
And the weaned child shall put his hand on the cockatrice’  
den.”

They shall not hurt nor destroy in all my holy mountain:  
For the earth shall be full of the knowledge of the Lord,  
As the waters cover the sea.  
And in that day there shall be a root of Jesse,  
Which shall stand for an ensign of the people;  
To it shall the Gentiles seek:  
And his rest shall be glorious.”

ISA. xi, 6—10.

It is unworthy the dignity of an immortal mind to have its affections absorbed in the vanishing splendors of earthly grandeur, and to feel proud of the paltry possessions and distinctions of this

sublunary scene. To foster a spirit of pride and vain-glory in the presence of Him “who sitteth on the circle of the heavens,” and in the view of the overwhelming grandeur and immensity of his works, is a species of presumption and arrogance, of which every rational mind ought to feel ashamed: and, therefore, we have reason to believe, that those multitudes of fools, “dressed in a little brief authority,” who walk in all the loftiness of pride, have not yet considered the rank they hold in the scale of universal being—and that a serious and profound contemplation of the immensity of creation would have a tendency to convince us of our ignorance and nothingness, and to humble us in the dust in the presence of the Former and Preserver of all worlds. We have reason to believe that the most exalted beings in the universe—those who are furnished with the most capacious powers, and who have arrived at the greatest perfection in knowledge—are distinguished by a proportional share of humility; for in proportion as they advance in their surveys of the universal kingdom of Jehovah, the more will they feel their comparative ignorance, and be convinced of their limited faculties, and of the infinity of objects and operations which lie beyond their ken. At the same time, they will feel that all the faculties they possess were derived from Him who is the original Fountain of existence, and are continually dependent for their exercise on his sustaining energy. Hence we find that the angelic tribes are eminently distinguished for the exercise of this heavenly virtue. They “cover their faces with their wings,” in the presence of their Sovereign, and fly with cheerfulness at his command to our degraded world, “to minister to them who shall be heirs of salvation,” and to execute whatever purposes he prescribes.

Throughout the sacred records pride is uniformly represented as abhorrent in the sight of the Almighty, while humility is marked with his approbation. “Every one that is proud in heart is an abomination to the Lord.” “God resisteth the proud, but giveth grace unto the humble.” “Thus saith the high and lofty One, who inhabiteth eternity, whose name is Holy: I dwell in the high and holy place, with him also that is of an humble and contrite spirit, to revive the spirit of the humble, and to revive the heart of the contrite ones.” This is a consideration which deserves the serious attention of young men when they first set out in the pursuit of science. They are apt to be puffed up with a vain conceit of their acquirements, when they have acquired only a smattering of learning, and have scarcely entered the porch of the temple of knowledge, and to vaunt themselves as if they were raised to a high elevation above the vulgar throng. Let such remember that even the illustrious Newton, after the vast acquirements he had attained, and the noble discoveries he had made, when he approached the hour of his dissolution, declared, “I do not know what I may appear to the world, but to myself I seem to have been only like a boy playing on the sea shore, and diverting myself with now and then finding a pebble or a prettier shell than ordinary, while the great ocean of truth lay all undiscovered before me.”

4. The subjects of astronomy to which we have directed the attention of the reader, afford a striking view of the condescension of the Divine Being toward man, especially in regard to the redemption of our fallen world. This sentiment seems to have been deeply impressed upon the mind of the Psalmist, when contemplating the

nocturnal heavens. Viewing the resplendent orbs every where around him in the canopy of the sky—the moon displaying her radiance—the planets in their courses, and the innumerable host of stars—his thoughts seem to have taken a flight into the regions of immensity, and by the guidance of his rational powers, and the assistance of the Spirit of inspiration, he takes an expansive view of the multitude, the magnitude, and the grandeur of those magnificent globes which roll in the distant tracks of creation. Overwhelmed with his views of the immensity of the universe, and of the perfections and grandeur of its Creator, he breaks out in the language of astonishment and wonder, “When I consider thy heavens, the work of thy fingers, the moon, and the stars which thou hast ordained; what is man that thou art mindful of him? and the son of man that thou visitest him?” Surveying with his intellectual eye the boundless extent of God’s universal empire, he shrinks as it were into nothing, and seems almost afraid lest he should be forgotten or overlooked amidst the immensity of beings over which the Divine government extends. And when he considered himself as a guilty creature in the presence of the Most High, his astonishment at the Divine condescension and grace must have been increased.

In no dispensation of the Almighty is this Divine condescension so strikingly displayed as in the economy of our redemption. Though countless myriads of worlds and intelligences are under his superintendence, and are incessantly celebrating his praise in the loftiest strains; and, consequently, though all the apostate inhabitants of our world might have been forever annihilated without being missed amidst the immensity of creation, yet, amazing to relate! the joyful announcement was made to our rebellious race, “God so loved the world, that he gave his only begotten Son, that whosoever believeth in him should not perish, but have everlasting life.” Soon after the fall of man this glorious intelligence was announced; and in every succeeding age God raised up a succession of prophets to announce the coming of the great Deliverer, “to foretell the sufferings of Christ, and the glory that should follow.” And when the time appointed in the decree of Heaven arrived, the promised Messiah was at length ushered into the world. A messenger from the celestial world, surrounded with resplendent splendor, was dispatched to the plains of Bethlehem, to make known his appearance in the world: “Behold,” says he, “I bring you good tidings of great joy, which shall be to all people. For unto you is born this day in the city of David, a Saviour, which is Christ the Lord.” And immediately a multitude of angels, having winged their flight from their heavenly mansions, joined in a chorus of congratulation and praise, “Glory to God in the highest, and on earth peace, good-will toward men.” Our Redeemer having passed through the scene of his public ministry, and manifested himself to be “the Son of God with power,” by a series of beneficent miracles, which he performed in every region of the land of Judea—was “led as a lamb to the slaughter,” delivered up to the severest sufferings for our sake, and “became obedient unto death, even the death of the cross.” And while he hung on the accursed tree, the most awful and striking miracles were exhibited to surrounding spectators, in order to display the dignity of Him who suffered, and the importance of that “decease which was accomplished at Jerusalem.” The sun was clad in black, the hea-

vens were arrayed in sackcloth, the day was turned into night, and, for three hours, darkness covered the whole land. The rocks rent asunder, the foundations of the earth did quake, the vail of the temple was rent in twain from the top to the bottom, the graves were opened, and many bodies of the saints who slept arose.

This was the most wonderful event, and the most illustrious display of Divine love that was ever announced to our world. What displays of Divine love and mercy may have been made to other worlds, and other orders of beings, we are not in a situation to determine. We dare not affirm that, in other regions of the Divine empire, similar displays have not been made; for we have never traversed the depths of immensity to ascertain all the dispensations of the Almighty in every province of creation. But we may boldly affirm that the mission and the death of Christ were the most wonderful events, and the most astonishing displays of mercy and love, that were ever made to our sublunary world. As the apostle of the gentiles has declared, there is a height and a depth, a breadth and a length in the love of God which is in Christ Jesus, that passeth knowledge. When we consider the depths of misery from which it raises us, the heights of felicity to which it exalts us, the boundless nature of its operations, and the everlasting continuance of all its blessings, we have reason to exclaim, in the language of admiration, with the apostle John, “Behold, what manner of love the Father hath bestowed upon us that we should be called the sons of God!” “Unto him that loved us, and washed us from our sins in his own blood, and hath made us kings and priests unto God and his Father; to him be glory and dominion forever and ever!”

5. The studies connected with the science of the heavens have a tendency to prepare the soul that has been previously enlightened and regenerated, for the employments of the future world. In that world the glory of the Divine perfections, as manifested throughout the illimitable tracks of creation, is one of the objects which unceasingly employ the contemplations of the blessed; for they are represented in their adorations, as celebrating the attributes of the Deity as displayed throughout the material universe: “Great and marvelous are thy works, Lord God Almighty. Thou art worthy, O Lord, to receive glory and honor and power; for thou hast created all things, and for thy pleasure they are and were created.” Before we can enter that world and mingle with its inhabitants, we must acquire a relish for their employments and some acquaintance with the objects which form the subject of their sublime investigations; otherwise we could feel little enjoyment in the society of heavenly intelligences, and the exercises in which they engage. The investigations connected with astronomy, and the frequent contemplation of its objects, may tend to prepare us for such celestial employments; as they awaken attention to such subjects—as they invigorate the faculties and enlarge the capacity of the intellect—as they suggest sublime inquiries, and excite desires for further information which may afterward be gratified—as they form the ground-work of the progress we may afterward make in that state, in our surveys of the Divine operations—and as they habituate the mind to take large and comprehensive views of the empire and moral government of the Almighty.

Those who have made progress in such studies, under the influence of holy dispositions, will cer-

tainly have higher and more perfect conceptions of the attributes of Jehovah than those who have given little or no attention to them; and it is not perhaps an unwarrantable supposition, that by such employments as most familiarize us with the glorious works of the Creator, and lead us to the contemplation of his moral perfections, we may be the better prepared for directing the views and investigations of such as have enjoyed fewer opportunities of instruction in the present state. For, we are informed in the sacred records, that "they who are teachers of wisdom shall shine as the brightness of the firmament, and they that turn many to righteousness as the stars forever and ever:" plainly intimating, that those who have made eminent advances in Divine knowledge, and applied it to its proper use, shall be distinguished with peculiar honors.

It is here of some importance to remark, that it is not merely a scientific view of the mechanical fabric of the universe that will prepare us for the employments of the celestial world, but the moral principles and the holy affections with which we are animated in all our studies and contemplations. A man under the influence of evil principles and passions, whose mind is actuated by pride, malignity, avarice, or revenge, is unqualified for a right contemplation of the works of God, for joining in the associations of pure and holy beings, and for engaging in the exalted services of the heavenly world. Unless the principles of "love to God" and "love to man" be engraven on our hearts, and interwoven throughout the whole of our mental frame, and manifested in the general tenor of our conduct, we can never enjoy true happiness either in the present state or in any other region of the universe; and such principles and dispositions can never be expected to be implanted in the soul, and brought forth into action, unless we comply with the requisitions contained in the word of God. The foundation of future felicity must be laid in "repentance toward God, and faith toward our Lord Jesus Christ." As sinners against the most high God, we stand in need of pardon, peace, and reconciliation. And "this is the record of God, that he hath given to us eternal life, and this life is in his Son." "This is his

commandment, that we believe on the name of his Son Jesus Christ,—whom God hath set forth to be a propitiation, to declare his righteousness for the remission of sins."

This is the first step in the path which leads to life eternal. And having entered on this course, we must be careful to bring forth "the fruits of righteousness," and to "glorify God in our bodies and spirits which are his." We must "add to our faith virtue; and to virtue knowledge; and to knowledge temperance; and to temperance patience; and to patience godliness; and to godliness brotherly kindness; and to brotherly kindness charity. For if these things be in us and abound," we shall neither "be barren nor unfruitful in the knowledge of our Lord Jesus Christ. For so an entrance shall be ministered unto us abundantly into the everlasting kingdom of our Lord and Saviour Jesus Christ." Prosecuting such a course with activity and perseverance, holding communion with the "Father of our spirits," and exhibiting a pattern of every Divine virtue and grace, we shall enjoy all that happiness which is consistent with our present state of trial and imperfection, and be gradually prepared for being "partakers of the inheritance of the saints in light;" where there is "fullness of joy," and "pleasures for evermore." In short, animated by such Divine principles and affections, we shall be fitted for holding intercourse with all the holy beings that constitute the moral and intelligent system, or the whole family of God throughout the universe, in whatever regions of the vast creation they may reside; for the principles and dispositions to which we have adverted must be common to all the pure intelligences that people creation, that have retained their primeval innocence and rectitude. When implanted in the heart, and interwoven through the whole of the mental constitution, they assimilate us to angels and every other class of holy intelligences, and qualify us for associating with the superior orders of intellectual natures—for entering into their sublime and comprehensive views—for bearing a part in their extensive schemes of universal beneficence—and for contributing along with them to the order and prosperity of God's universal and everlasting kingdom!

# APPENDIX.

## I.

### NEW DISCOVERIES IN THE PLANETARY SYSTEM.

**THE PLANET NEPTUNE.**—The discovery of this planet forms a remarkable era in the history of astronomy. It was ascertained to exist by calculations founded on the principles of physical astronomy, and on the discrepancies which were found to exist between the observed and the calculated places of *Uranus*. It was conceived that probably some disturbing body existed beyond that planet, which had hitherto eluded the observation of astronomers, and which produced the irregularities to which we allude. The following is a brief sketch of the history of this discovery:—

The Rev. Dr. Hussey, in 1834, wrote to Professor Airy, of the Royal Observatory, Greenwich, that he conjectured the possibility of some disturbing body beyond *Uranus*, and that he had found that Bouvard and Hansen had been in correspondence on a similar conjecture. In 1842, the late distinguished astronomer, Bessel, in conversation with Sir John Herschel, in reply to the question whether the deviations in question might not be due to the actions of an unknown planet, stated, that he thought it highly probable that such was the case. But, until September, 1845, there was not produced by any astronomer a research that was calculated to decide this question. It was about this time that Mr. J. C. Adams, fellow and assistant of St. John's college, Cambridge, communicated to Professor Challis, of the Cambridge Observatory, values which he obtained for the heliocentric longitude, eccentricity of orbit, longitude of perihelion, and mass of an assumed exterior planet, deduced entirely from unaccounted-for perturbations of *Uranus*. The same results, somewhat corrected, were left at the Observatory of Greenwich, about the end of the following October, in a paper containing the following statement:—“According to my calculations, the observed irregularities in the motion of *Uranus* may be accounted for, by supposing the existence of an exterior planet, the mass and orbit of which are as follows:—

Mean distance (assumed nearly in accordance with Bode's law) . . . . .	30.84
Mean sidereal motion in 365 $\frac{1}{4}$ days . . . . .	1° 30' 9"
Mean longitude, 1st October, 1845 . . . . .	323° 24'
Longitude of perihelion . . . . .	345° 55'
Eccentricity . . . . .	0.1610
Mass, that of the sun being unity . . . . .	0.0091656

These were the first intimations of the new planet that were ever made public; and at, or near the position here assigned to it, it was afterward seen by Professor Challis of the Cambridge Observatory. Had Mr. Airy attended to the above, as he ought to have done, Mr. Adams would have enjoyed the undivided merit of being the first discoverer of this planet; and we cannot but feel indignant at the apathy and neglect of the Royal

Astronomer, especially when we consider that Mr. Adams made two journeys to Greenwich to explain this matter, and left his papers and calculations at the Observatory.

In the *Comptes Rendus*, for June 1, 1846—eight months after Mr. Adams had made known the elements of the new planet's orbit to the English astronomers—M. Le Verrier gave a memoir on the theory of *Uranus*, in which he affirmed the necessity of admitting the hypothesis of an exterior planet. No elements of the orbit or mass were given, but its longitude, it was stated, should be, for the beginning of 1847, about 325°. He communicated his principal conclusion to the astronomers of the Berlin Observatory on September 23d, and, guided thereby, and comparing the observations with a star map, M. Galle found the planet on the same evening.

Professor Challis, before this time, in consequence of a laborious research, had actually seen the planet. On July 30th, he went over a zone of the heavens, nine minutes broad, in such a manner as to include all stars up to the eleventh magnitude. On August 4th, he took a wider zone, and recorded a place of the planet. His next observations were on August 12th, when he met with a star of the 8th magnitude, in the zone which he had gone over on July 30th, which did not then contain this star. Of course, this was the planet—the place of which was thus recorded a second time, in four days of observing. A comparison of the observations of July 30th and August 12th, would, according to the principle of search which he employed, have shown him the planet; but he did not make the comparison until after the detection of it at Berlin. The planet, however, was secured, and two positions of it recorded, *six weeks* earlier than in any other observatory, and in a systematic search expressly undertaken for that purpose, so that Mr. Challis, though not acknowledged as the first discoverer, has at least the satisfaction of having seen and recorded the position of this new-found planet six weeks earlier than he who is considered the real discoverer.

This planet appears like a star of the 8th magnitude, and consequently may be seen with a moderate degree of magnifying power; but it will be difficult to distinguish it from small neighboring stars, unless with a very high power, when a disc may be perceived. Its distance from the sun is reckoned about 30 times that of the earth, or 2,850,000,000, that is, two thousand eight hundred and fifty millions of miles, or, more than a thousand millions of miles beyond the orbit of *Uranus*. The apparent disc of this planet subtends an angle of something more than 3 seconds, and its diameter will consequently be nearly 50,000 miles. Of course, it is about 250 times larger than the Earth, and three times larger than *Uranus*; and above a

hundred times larger than the whole mass of the Earth and Moon, Venus, Mercury, Mars, Ceres, Pallas, Juno, and Vesta taken together. So that here we have a planet, which has been hid from the view of mortals in the profundity of space for thousands of years, exceeding in bulk a large retinue of spacious worlds; Jupiter and Saturn alone are its superiors. Its apparent motion when discovered was retrograde at 4 seconds per day. Its revolution round the sun is supposed to be accomplished in 190 years.

Mr. Lassell of Starfield, near Liverpool, stated that soon after its discovery, he had different views of it, and believes that he may confidently assert that it is surrounded by a Ring like that of Saturn, placed three diameters from the body of the planet. This discovery appears to be confirmed by some late observations of Professor Challis. "I have been able," says he, "with the Northumberland telescope, to verify Mr. Lassell's suspicions of a Ring. I first received the impression of a ring on the 12th January, 1847. Two independent drawings, made by myself, and my assistant, Mr. Morgan, gave the same representations of its appearance and position. The ring is very little open. Its diameter makes an angle in the south preceding quadrant of 66 degrees with the parallel of declination. The ratio of the diameter of the ring to that of the planet is by estimation that of 3 to 2. I am at a loss to account for my not having noticed the ring earlier."

It also appears that Neptune is attended with at least one satellite, which Mr. Lassell has several times seen. In a letter dated September 20, 1847, he informs the editor of the *Times*, that "he has ascertained the period of this satellite to be 5 days, 20 hours, 50 minutes, 45 seconds. The projected orbit is a narrow ellipse, with an axis inclined to about 28 degrees to the ecliptic, and with its semi-axis subtending about 18 seconds, so that the satellite is about 250,000 miles from the planet. This satellite is much brighter in the preceding than in the following half of its path. This variation seems to show that one side of the satellite has less light than the other." It is likewise evident that this satellite must be a body of very considerable size, otherwise, it could not be visible at such an immense distance. It is probably much larger than any of the satellites of Jupiter or Saturn, and may far exceed our globe in magnitude. The heliocentric longitude of this planet, on the 4th of August, 1846, was  $326^{\circ} 39'$ , and the north polar distance  $102^{\circ} 57'$ .

The discovery of this far distant planet, in the manner in which it was effected, constitutes not only a new era in the progress of celestial science, but also evinces the perspicacity of the human intellect, and the certainty and uniformity of those physical laws by which the bodies of the planetary system are directed, and that the law of gravitation is extensive in its influence, reaching far beyond what were formerly considered the boundaries of our system, and probably exerting its energies throughout all the worlds that roll through the spaces of infinitude. We have here a new confirmation of the theory of universal gravitation. The first step in the exhibition of that law was, the discovery made by Newton that the earth attracts the moon. The principle was also found to explain the revolution of the planets round the sun. Beside, it was found that the movements of the secondary planets round their primaries are owing to the same cause. The application of this law likewise explained certain anomalies in the motion of the moon and planets, which were otherwise difficult to account for. A great inequality

in the movements of Jupiter and Saturn, which was long unaccounted for, was at length traced to their reciprocal action on one another by the operation of this law. The effects of the attraction of planets that could be observed, and whose names were known were thereby calculated. In respect to the newly discovered body—the mean distance and position—the mass and the form of its orbit, were all unknown. But, by its observed effects, these were all so well determined as to guide the observer almost to the very point of the heavens where it was first seen. This fact stands almost alone in the records of astronomical science. There has been no discovery of the same kind before it in the annals of astronomy, and it may lead to other discoveries of a similar kind. We have now no reason to conclude, that we have as yet described the utmost boundaries of the solar system, since a body of so great magnitude has been ascertained to exist and to prosecute its annual course round the sun, at nearly double the distance of Uranus. If there be another planet or more beyond the orbit of Neptune, the observations of a number of years upon the movements of this body may lead to a like result again, and to bring to view other spacious orbs which have hitherto been concealed in those distant regions of space. It is in this way that the Creator crowns the exertions of human genius and the investigation of his works with success—by opening to our view a more expansive prospect of his boundless and eternal empire.

#### THE PLANET HEBE.

The brilliant discovery of the planet Neptune by Adams and Le Verrier, has been closely followed by that of another, which has been detected by M. Hencke, the discoverer of Astræa. On the 1st of July, 1847, at 10h. 40m., P. M., M. Hencke, of Dresden, discovered a second star, not previously marked in his map, of about the 9th degree of magnitude, in  $257^{\circ} 6'$  right ascension, and  $3^{\circ} 42'$  south declination. This new planet was observed on the 5th July from the Observatory of Berlin in the meridian, and in the refracting telescope. This body is considered as belonging to the smaller planets between Mars and Jupiter. This planet has been subsequently observed by M. Schumacher, M. Encke, M. Rumker, Mr. Hind, Professor Challis, Dr. Peterson and Mr. Lassell. Mr. Hind has computed its elements as follows:

Epoch of mean anomaly, July, 1847, Green-	
wich mean time . . . . .	$283^{\circ} 50' 54''$
Longitude of perihelion . . . . .	$8^{\circ} 17' 24''$
Inclination . . . . .	$137^{\circ} 25' 35''$
Eccentricity . . . . .	$238910$
Mean diurnal motion . . . . .	$856'$
Sidereal period . . . . .	4,004 years

From these statements it appears that this planet comes between Vesta and M. Hencke's other planet Astræa. It has been named *Hebe*, following the nomination of the illustrious Gauss, to whom the office was delegated by Hencke.

#### THE PLANET IRIS.

On the night of Friday the 13th of August, 1847, only about six weeks after the discovery of Hebe—Mr. Hind, the astronomer at Mr. Bishop's observatory, Regent's Park, London, discovered an asteroid, which he believed was a new planet belonging to the group between Mars and Jupiter. Subsequent observations have confirmed the accuracy of that opinion, and placed beyond doubt this further triumph of English astronomers



Mr. Hind has since favored the scientific world with the following particulars of this interesting wanderer, now, for the first time recognized as belonging to our solar system.—“In addition to the Berlin maps,” says Mr. Hind, “which we have revised; and in some instances corrected, elliptical charts of stars down to the 10th magnitude have been formed for some of the hours of Right Ascension, which it is Mr. Bishop’s intention to publish as soon as they are completed. On the 13th of August, I compared Wolf’s map with the heavens, and was surprised to find an unmarked star of 8.9 magnitude in a position which was examined on June 22d and July 31st, without any note being made. The mere existence of a star in a position where before there was none visible, would not have been sufficient to satisfy me as to its nature, because during an eight months’ search, I have met with very many variable stars, a class which I believe to be far more numerous than is generally supposed. But, on employing the wire micrometer, we were enabled, in less than half an hour, to establish its motion, and thus to convince ourselves that I had been fortunate enough to discover a new member of the planetary system. It may appear to many rather bold to announce the existence of a new planet from the detection of so small an amount of motions as 2".5 in right ascension; but such is the firm mounting of the large refracting telescope, and the perfection of the micrometers, (for which we have to thank Mr. Dollond), that a far smaller change would have been sufficient to convince us of the nature of the object in question.” The following are all the observations yet made:—

	h. m. sec.		R. Ascen. of Iris.		S. Declin.	
	h.	m. sec.	h.	m. sec.	13° 27'	21" .5
August 13,	9	39 46	19	57 30	13° 27'	21" .5
	10	37 24	19	57 28	13	27 27 .6
	14	9 23 58	19	56 38	13	29 14 .0
	15	9 0 39	19	55 47	13	31 4 .3

The name *Iris* was fixed upon by Mr. Bishop as an appropriate name for this new planet. The symbol adopted for its designation is a semicircle with an interior star. Mr. Hind says, “This planet has been detected in a systematic search instituted expressly with the view to the discovery of such a body, and commenced in November, 1846. The Berlin maps were employed as far as they extend: small stars of the 9th or 10th magnitude, not marked in the maps, being inserted from time to time, as they came under examination.” Observations of *Iris* have likewise been made by Professor Challis, Mr. Graham, Dr. Peterson at Altona, M. Rumker at Hamburg, and Professor Encke at Berlin.

#### THE PLANET FLORA.

Since the discovery of the planet *Iris*, Mr. Hind, at Mr. Bishop’s observatory, South Villa, Regent’s Park, has discovered another, within little more than two months after *Iris* was discovered. This new body was discovered on October 18, 1847. A few hours’ observation proved it to be a new planet—the eighth of the remarkable group between the orbits of Mars and Jupiter. Since the epoch of discovery the brightness of the planet has considerably increased, and now equals that of a star of the eighth magnitude. At Mr. Bishop’s request, Sir John Herschel has named it “*Flora*” with a flower (a rose) for the symbol. This new body has also been observed by Professor Challis, E. I. Cooper, Esq., Mr. Graham, Professor Encke, Professor Schumacher, M. Peterson and M. Rumker.

From the above statements it appears that three

new primary planets have been brought to light during the year 1847, and that, too, within less than the space of four months, the first of them having been discovered on the first of July, and the third on the 18th of the following October. It is remarkable, too, that they all belong to that class of comparatively small bodies, sometimes called *Asteroids*, which move between the orbits of Mars and Jupiter, and are all invisible to the naked eye. Those bodies revolve nearly at the same distance from the sun, and the times of their revolutions round the sun are not much different from each other, and they are now found to be at least *eight* in number. There is a considerable degree of mystery that hangs over the facts and circumstances connected with these bodies, which prevents us from forming precise and definite conceptions respecting their nature and destination. It is generally supposed that they once formed the component parts of a large planet, which formerly revolved near the regions they now occupy, but, by some powerful internal force, had been disrupted into a number of smaller planets, which form the bodies which have been lately discovered. How many of these smaller bodies may exist it is now impossible to determine, since others may still be discovered; for it would be as unreasonable to conclude that we have now discovered the whole of them, as it would have been when only two or three of them were discovered. Between the beginning of 1801, and 1807, four of these bodies had been detected, but no further discovery was made in reference to them until December, 1845, when *Astræa* was discovered.

Various inquiries are suggested to the mind when contemplating the peculiar phenomena which these bodies present. If these small planets once formed the component parts of a large planet, at what period did the disruption take place? Was that planet then inhabited? And if inhabited what was the fate of its inhabitants? Were they entirely destroyed by the awful catastrophe? or, did the inhabitants of the different fragments fly off along with that portion of the original planet which they occupied? Are these bodies still inhabited? or, are they flying like shattered masses, and barren deserts, through the voids of space? And if so, are they ever again to be re-peopled? To such inquiries, however, no satisfactory answers can be expected while we remain in the present state. On the other hand, if we do not admit the hypothesis of a large planet having been disrupted, it is very difficult to account for the present position, motions, and other phenomena of these bodies, so very different from the harmony, proportion, and order, which characterize the other arrangements of the solar system. As already stated, they are nearly of the same distances from the sun, and perform their revolution nearly in the same periods; their orbits are more eccentric, and have a much greater degree of inclination than those of the other planets: and what is very singular and unaccountable, *their orbits cross each other*, so that there is a possibility of these planets impinging upon each other in the course of their revolutions. These circumstances seem to indicate that the bodies in question are not in that order and arrangement in which we should suppose an all-wise Creator would have placed them at their original creation, so that, whatever view we take of these anomalous bodies, there appears to us something inexplicable, mysterious, and incomprehensible. But we may rest assured that their present state, whatever it may be, is in full accordance with the

wisdom, rectitude, and benevolence of the *Moral Governor* of the universe.

#### RAPID PROGRESS OF ASTRONOMICAL DISCOVERY.

Since the beginning of the 17th century, a little before the telescope was applied to the heavens, no less than thirty-one bodies, unknown before, have been added to our views of the Solar System. In the year 1698, seven bodies were known to belong to our system, namely, the Sun and Moon, Mercury, Venus, Mars, Jupiter, and Saturn. In 1700, there had been added eleven moving bodies, namely, four satellites of Jupiter, five of Saturn, the Earth itself, which was now fully recognized as a planet, and Halley's comet, though the prediction had not been verified. In 1800, there had been added *nine*, namely, Uranus and its six satellites, with two satellites of Saturn. These were all discovered by the late Sir Wm. Herschel; and this celebrated observer, at his death, left the solar system half as large again, in number of bodies, as he found it. Since the beginning of the year 1800, there have been added twelve, namely, *Vesta*, *Juno*, *Ceres*, *Pallas*, *Astræa*, *Hebe*, *Iris*, *Flora*, *Neptune*, the satellite discovered by Mr. Lassell as revolving round the planet *Neptune*, *Encke's comet*, and *Biela's comet*.

Notwithstanding the discoveries which have lately been made in the planetary system, and in other regions of the heavens, we are not to imagine that we have yet arrived at boundaries in creation, beyond which we cannot pass. Only a few years have yet passed since the planet *Saturn* was considered as the utmost boundary of our planetary system, whose orbit is removed 900 millions of miles from the sun. But now, planets have been discovered at double and treble this distance, at eighteen hundred millions, and at three thousand millions of miles from this central luminary, and at such immense distances retained in their orbits, and guided by the influence of the attractive powers of the sun. The planet *Neptune* moves in an orbit five thousand seven hundred millions of miles in diameter, and about eighteen thousand millions of miles in circumference; and were a steam carriage to move round this vast circle at the rate of twenty miles an hour, it would require more than a hundred thousand years before it would complete the vast circuit. As we have no reason to conclude that we have not reached the utmost bounds of our system, it is not at all improbable that planets of a large size may exist far beyond the orbit of *Neptune*, which may yet be discovered by the persevering efforts of our astronomers, and some of which may never be visible to mortal eyes. It will now be more difficult than formerly to make delineations of the orbits of the planets, when they are intended to be represented in the relative proportions of their distances from the sun, unless the delineation be made on a very large scale, for otherwise the orbits of *Mars*, the *Earth*, *Venus*, and *Mercury*, would appear so close to each other as scarcely to be distinguished.

On the whole, what further discoveries may yet be made in the celestial regions it is scarcely for us to anticipate. But in proportion to the number of those who devote themselves to celestial observations, and in proportion to the improvements that may be made on telescopes, and other instruments of observation, may we expect that still more brilliant discoveries will be unfolded to our view. It is to be hoped that American astronomers will, ere long, be instrumental in making new discoveries in the heavens, since

some of them have lately procured most powerful instruments of observation. It is to be hoped that Professor Mitchell, of Cincinnati, who has been furnished with an observatory, and an excellent instrument of observation, will soon comply with the requisition of *Struve*, and measure all the double and multiple stars south of the equator. It is also confidently expected that Mr. Bond of Cambridge, Massachusetts, will follow up his discovery of analyzing the great nebula of *Orion* by similar discoveries in the nebulous regions of the heavens. The great Cambridge achromatic telescope is an instrument which does honor to the Harvard University, and to the United States. From what it has already performed, it appears scarcely inferior to the monster telescope of the Earl of Rosse, 54 feet in length, and 6 feet in diameter.

## II.

### BRIEF SKETCH OF THE HISTORY OF ASTRONOMY.

ASTRONOMY was undoubtedly one of the earliest of the sciences cultivated by the human race. Some of its facts and first principles must have been known from the beginning of the world. For when the shades of night have opened to view the azure firmament, diversified with a multitude of shining orbs—the moon walking in brightness—the planets moving in their courses—and the host of stars displaying their diversified radiance—such a scene must have attracted the attention of every spectator, and led him to observe their apparent motions, and to inquire into their order and arrangement, and their use in measuring the exact length and proportions of days, and months, and years. Hence our English poet, Milton, very properly represents our first progenitors, Adam and Eve, celebrating the praises of their Maker, after taking a survey of the nocturnal heavens.

*Adam.* "These are thy glorious works, Parent of Good,  
Almighty! thine this universal frame,  
Thus wondrous fair; thyself how wondrous then!  
*Eve.* Unpeakable! who sittest above these heavens  
To us invisible or dimly seen  
In these thy lowest works; yet these declare  
Thy goodness beyond thought, and power divine."

Hence we find that *Josephus*, in his book of the "Antiquities of the Jews," relates that "Seth and his descendants were persons of happy tempers, and lived in peace, employing themselves in the study of astronomy, and in other researches after useful knowledge." He also remarks that, "God indulged the antediluvians with a long life, that they might bring astronomy and geometry to perfection." And the long lives of men, at that period, when many reached the age of eight or nine hundred years, had a tendency to improve the science of astronomy; since the same individual might observe the planet *Saturn* go through more than thirty revolutions. We have, therefore, reason to conclude that many of the antediluvians were intelligent astronomers: but their observations, if they were ever recorded, must have perished in the general deluge, unless *Noah*, who was a wise and good man, had secured some of the most valuable of them in the ark, and transmitted the results to his posterity.

After the deluge, the nations most noted for the cultivation of the science of the heavens were the Chaldeans, the Egyptians, and the Chinese. It is remarked by *Josephus* that *Abraham* was a most attentive observer of the stars; that he was a person of great sagacity, both for understand-

all things, and persuading his hearers, and that he first brought astronomy from Chaldea into Egypt.

The Egyptians appear to have made some progress in astronomy, at as early a period as the Chaldeans. Their Pyramids, the most ancient monuments in the world, prove their skill in practical astronomy, as they are all situated in such a manner, that their several sides front very exactly the four cardinal points, east, west, north, and south. The system adopted by the Egyptians was the following: they conceived that the planets Mercury and Venus revolved like satellites, around the sun, their orbits being carried along with him in his revolution round the earth. They supposed the earth immovable as the center of the system, and the other celestial bodies to turn around the same center; first the moon, then the sun, about which they supposed Mercury and Venus to revolve, next the planet Mars, then Jupiter, next to Jupiter Saturn, and lastly the sphere of the fixed stars. The Chinese pretend that their nation studied astronomy soon after the flood, and date their astronomical knowledge from Fohi, the first of their kings; supposed by some to have been Noah, as it is understood that he journeyed with his children in the direction of China, about the time of the building of the tower of Babel.

Among the Greeks, astronomy was cultivated by Thales, the Milesian, Anaxagoras, Anaximander, Pythagoras, Aristarchus and others. Pythagoras, who flourished about five hundred years before the Christian era, taught that the sun was in the center of the universe; that the earth is globular, and moves round the sun; that Venus is the morning, as well as the evening star; that the moon reflects the sun's rays, and is inhabited; that the stars are worlds, and that comets are wandering stars. This is nearly the system which was restored by Copernicus, in the fifteenth century.

Hipparchus, born at Nice, in Bithynia, appears to have made considerable advances in the cultivation of every branch of astronomy. He flourished about one hundred and forty years before Christ. He was among the first astronomers on record who attempted to number the stars, and to determine their exact positions. He was first induced to commence this labor in consequence of the appearance of a new star, in order that succeeding astronomers might learn whether any changes take place in the heavens.

Ptolemy, a native of Pelusium, in Egypt, born in the year 69, is the most ancient astronomer whose works have been handed down to our times. His *Almagest*, or the great composition, is that to which we are indebted, not only for his own observations, but for almost all that remains of Hipparchus, Aristillus, Timocharis, and the ancient Babylonians. According to the system of Ptolemy, the earth is immovable in the center of the universe, and the planets move round it in the following order: first the moon, then Mercury and Venus; next to Venus the sun; then Mars, Jupiter, and Saturn, in the order here stated; and above all these, the firmament of the fixed stars, all which were conceived as revolving around the earth every twenty-four hours. He supposed that the planets moved round the earth, each in a vast solid transparent globe, having the planet attached to its surface; and as these transparent spheres did not account for all the motions and apparent irregularities of the heavenly bodies, he contrived other and still more complicated machinery, such as cycles, epicycles, deferents, etc., in order, if possible, to solve appearances. This

system, notwithstanding its absurdity, and its contrariety to the appearances of the universe, continued in vogue, even among the learned, for the space of more than one thousand four hundred years, or until the middle of the fifteenth century. During this period, a few individuals appeared who cultivated astronomy, such as Almansor, Almanon and others among the Arabians; Ulugh Beigh, a prince of Tartary; Alhazen, an Arab in Spain; Alphonso X, king of Castile; Roger Bacon, and several others; but they all adopted the absurd hypothesis of Ptolemy.

About the beginning of the sixteenth century, Copernicus, a bold and original genius, began to be distinguished for his attainments in astronomy. Perceiving that the clumsy and unnatural system of Ptolemy could never account for the motions and appearances of the celestial orbs, he adopted the Pythagorean system, which had been broached five hundred years before Christ, and wrote a profound treatise in confirmation of it, entitled, "Astronomy Restored; or, The revolutions of the Celestial Orbs." With a bold and daring hand, he dashed the crystalline orbs of Ptolemy into pieces, swept away his cycles, epicycles, and deferents, placed the sun in the center of the system, removed the earth from its quiescent state, and set it in motion through the regions of the firmament, in company with the other planetary orbs. This system was at first violently opposed, both by the vulgar, the dignitaries of the Romish church, and pretended philosophers, as contrary both to sense, reason and Scripture, and many of its abettors were subjected to violent persecutions. But it is now universally received by all men of learning, and by every one who has investigated the motions and other phenomena of the heavens. It has opened to our view the harmony and order of the planetary system, the wisdom and intelligence of its great Author, and laid the foundation of all the discoveries which have subsequently been made in this science. It was afterward ably supported by the writings and observations of Galileo, Kepler, Gassendi, Hevelius, Huygens, Cassini, and other celebrated astronomers, by whom its principles have been established on a foundation stable and permanent as the laws of the universe.

About sixty or seventy years after the publication of this system, the invention of the telescope, and the discoveries made with this instrument by Galileo, tended to confirm its principles, and to expand our views of the sublimity, the variety, and multitude of the objects which the universe displays. This illustrious astronomer first discovered, by his telescope, the satellites of Jupiter, the phases of Venus, the spots of the sun, and the rotation of this globe round its axis, the mountains and vales in the moon, the stars in the Milky Way, and an extraordinary phenomenon, which he imagined to be two small globes, connected with the planet Saturn. These discoveries were made about the year 1610, soon after the telescope was invented. About forty-eight years afterward, Huygens, a celebrated mathematician and astronomer, in Holland, with telescopes of a much larger size than those of Galileo, discovered that the phenomenon connected with Saturn was, in reality, an immense ring surrounding that planet, and thirty thousand miles distant from every part of it. He, at the same time, discovered the fourth satellite of Saturn; and in these and other observations he used telescopes of his own construction of twelve, twenty-three, and even one hundred and twenty feet in length. Some time afterward, Cassini, a French astronomer, discovered the first, second,

third, and fifth satellites of Saturn, and the periods of the rotation of Mars and Venus.

About the period to which we now allude, flourished the illustrious Sir Isaac Newton, who laid the foundation of physical astronomy. About the year 1666, when in the twenty-fourth year of his age, he retired from Cambridge into the country on account of the plague, and sitting one day in an orchard, under a tree, an apple happening to fall upon his head, led him into a number of reflections. Reflecting on the power by which all terrestrial bodies gravitate toward the earth, it occurred to him, that as this power is not sensibly diminished in any distance to which we can recede from the earth's center, there seemed reason to conclude that it extended much farther than it was generally supposed, and even might extend as far as the moon; and if this were true, he concluded that her motion would be influenced by it, and that probably it was this very force which retained her in her orbit. Following out these sublime conceptions, he began the composition of his immortal work, the "Principia," which was published in 1687, in Latin, under the title of "Mathematical Principles of Natural Philosophy." He also invented a reflecting telescope, which bears his name.

Contemporary with Newton were Dr. Hooke, Flamsteed, Halley, Bradley, Roemer, Richer, Picard, Maraldi, and others, whose labors greatly contributed to the improvement of astronomy. Flamsteed was the first astronomer royal in the Observatory at Greenwich, and, for nearly half a century, was assiduous in his observations of the heavenly bodies. He formed a catalogue of more than three thousand stars, with their right ascensions, longitudes, solar distances, and apparent magnitudes. Roemer, a Danish astronomer, was the first who discovered the progressive motion of light. By comparing the eclipses of the first satellite of Jupiter with the times of their immersions and emersions given by the tables of Cassini, he found that the error of the tables depended on the distance between Jupiter and the earth, and hence he concluded that the motion of light was not instantaneous, and that it moved across the diameter of the earth's orbit in about sixteen minutes, or at the rate of 192,000 miles in a second.

Few discoveries were made in the heavens from the beginning of the eighteenth century until the period when Sir W. Herschel applied his large telescopes to the spaces of the firmament. His discoveries have greatly extended our views both of the planetary system, and of the sidereal heavens. On the 13th March, 1781, he discovered a new planet beyond the orbit of Saturn, to which he gave the name of Georgium Sidus; but it is now generally distinguished by the name of Uranus. On the 11th January, 1787, he discovered the second and fourth satellites which move round this planet; in 1790 and 1794, he discovered four other satellites revolving round the same body. In 1789 he discovered the sixth and seventh satellites of Saturn; he also determined the rotation and figure of this planet—discovered that it had a double ring, and was marked with several belts parallel to its equator. His son, Sir J. Herschel, has also distinguished himself by his unwearied observations on the heavens. In conjunction with Sir J. South, he produced a catalogue of 380 double stars, whose distances and angles of position they had determined with the utmost precision. Sir J. Herschel afterward produced a list of upward of 3300 double and triple stars, from his own solitary observations, accompanied

with all the micrometrical measurements; and about ten or twelve years ago, he went to the Cape of Good Hope for the purpose of making observations in the southern region of the heavens, and made some interesting discoveries. On the 1st of January, 1801, M. Piazzi, a Sicilian astronomer, discovered a small planet between the orbits of Mars and Jupiter, which has been named Ceres. On the 26th March, 1802, Dr. Olbers, of Bremen, discovered another planet, near the same region, which is named Pallas. On the 1st September, 1804, Mr. Harding, of Lilienthal, discovered another, which is named Juno, distinguished for the great eccentricity and inclination of its orbit. On the 26th March, 1807, Dr. Olbers discovered a fourth planet, which he named Vesta. The latest discovery of this kind we have to record was made by Mr. Hencke, of Driesen, on the 8th December, 1845, when he discovered another planet somewhat similar to the four now mentioned, which is nearly at the same distance from the sun, and accomplishes its revolution in nearly the same period as the others. This planet has been named Astræa.

In the present day there are many distinguished cultivators of astronomical science, from whose observations and researches new discoveries may be expected. The names of South, Herschel, Airy, Smyth, Robinson, the Earl of Rosse, Schumacher, Strüve, Harding, Bessel, Arago, and a multitude of others, are well known as distinguished cultivators of the science of the heavens. It is to be hoped that the Earl of Rosse, by means of the large and splendid telescope he has lately erected, will be enabled to make new discoveries, and to enlarge our views of the grandeur of the sidereal heavens. He has already analyzed some of the nebulae, and shown them to consist of immense clusters of stars which could not be perceived by any former telescopes; and this, we would hope, is only a prelude to still more sublime discoveries. What further advances astronomy may yet make, we dare not venture to anticipate. The number of individuals who devote themselves to this study is gradually increasing; its instruments of observation are rapidly improving; and we can scarcely set boundaries to the discoveries that may yet be made. In future ages, man, by the improvements in optical and other instruments, may be able to penetrate much farther into the distant regions of the universe than he has hitherto done, and may desery myriads of objects which have hitherto remained invisible in the unexplored regions of immensity. And after all the discoveries which mortals can bring to view from this terrestrial sphere, the greater part of the works of the Almighty will still remain to be explored throughout the ages of eternity.

### III.

#### EXPLANATION OF ASTRONOMICAL TERMS

*Aberration*, an apparent change of place in the fixed stars, which arises from the motion of the earth combined with the motion of light.

*Achernar*, a fixed star of the first magnitude, in the constellation Eridanus, R. A. 1 hour, 31 minutes.—Dec. 58 degrees, 16½ minutes.

*Achronical* rising or setting of a planet, or star, is when it rises at sunset, or sets at sunrise.

*Aldebaran*, a fixed star of the first magnitude in the head of the constellation Taurus; sometimes called the *Bull's eye*.

*Aerolites*, or air-stones, are semi-metallic substances which are found to fall from the atmosphere in different countries. Some philosophers have imagined that they are the fragments of a planet that had been burst asunder.

*Algol*, a star in Medusa's head which varies from the second to the fourth magnitude.

*Alioth*, a fixed star in the tail of the Great Bear.

*Almicanters*, imaginary circles, which are supposed to be drawn parallel to the horizon, and to pass through every degree of the meridian, to show the altitude of a celestial object above the horizon.

*Altitude*, the height of the sun, moon, or stars above the horizon, reckoned in degrees and minutes, on a vertical circle.

*Amphiscii*, a name given to the inhabitants of the torrid zone, on account of their shadows falling at one time of the year toward the south, and at another time toward the north.

*Amplitude*, an arc of the horizon, contained between the east or west point of the heavens, and the center of the sun or a star at the time of its rising or setting.

*Anomaly* (the true), the distance of a planet in signs, degrees, etc., from that point of its orbit which is farthest from the sun. The mean anomaly is, that which would take place if the planet moved uniformly in the circumference of a circle.

*Antoeci*, a name given to those inhabitants of the earth, who live under the same meridian, and at equal distances from the equator, but on opposite sides of it.

*Antipodes*, those inhabitants of the earth who live diametrically opposite to each other, or walk feet to feet, on opposite sides of the globe.

*Aphelion*, that point in the orbit of a planet in which it is at its greatest distance from the sun.

*Apogee*, that point in which the sun, or a planet, is farthest distant from the earth.

*Apsides*, the two most remote points of a planet's orbit, otherwise termed its aphelion and perihelion. A line joining those points is, the line of the apsides.

*Armillary sphere*, an instrument composed of the principal circles which are drawn on an artificial globe.

*Ascii*, the inhabitants of the torrid zone; so called because the sun being twice a year in their zenith, their bodies at those times cast no shadow.

*Axis* of the earth, or of a planet; an imaginary line passing through the center from one pole to another, round which they perform their diurnal rotation.

*Azimuths*, great circles which pass through the zenith and nadir perpendicular to the horizon. The azimuth of a celestial body is an arc of the horizon contained between the east and west points, and a vertical circle passing through the center of that object.

*Belts*, zones surrounding the body of Jupiter and Saturn.

*Bissextile* (or Leap Year), which happens every fourth year, contains 366 days; one day being added to the month of February.

*Cardinal points* of the compass; the east, west, north and south points.

*Cardinal points* of the ecliptic; the first points of the signs, Aries, Cancer, Libra, and Capricorn.

*Centrifugal force*, that force by which any revolving body endeavors to fly off from the center of motion in a tangent to the circle it describes.

*Centripetal force*, the tendency which a body has to the center of its revolution.

*Comets*, erratic bodies belonging to our system, which move round the sun in very eccentric orbits, distinguished by their fiery tails and nebulous aspects.

*Colures*, two imaginary circles or meridians, one of which passes through the solstitial points Cancer and Capricorn, and the other through the equinoctial points Aries and Libra.

*Conjunction*, is when two or more stars, or planets, are in the same part of the heavens.

*Constellation*, an assemblage of stars.

*Cosmical rising* or setting of a planet, or star, is when it rises with the sun in the morning, or sets with him in the evening.

*Crystalline heavens*, two solid orbs by means of which the ancients attempted to account for the apparent motions of the fixed stars.

*Cusps*, the points or horns of the moon, or of a planet.

*Cycle of the moon*, a revolution of nineteen years, in which time the conjunction and lunar aspects are nearly the same as they were nineteen years before.

*Day* (astronomical), the time between two successive transits of the sun's center over the same meridian, which always begins and ends at noon.

*Day* (sidereal), the time which elapses during the rotation of the earth from one star until it returns to the same star again, and consists of 23 hours, 56 minutes, 4 seconds.

*Declination* is the distance of any celestial object north or south from the equator, reckoned in degrees, minutes, etc., upon a circle which is perpendicular to it.

*Degree*, the 360th part of a circle, or the 30th part of a sign.

*Disc* of the sun, or moon, is its round face, which, on account of the great distance of the object, appears flat.

*Digit*, the 12th part of the sun's diameter, which is used in the calculation of eclipses.

*Diurnal motion* of the earth, its rotation on its axis.

*Eccentricity*, the distance between the center of a planet's orbit, and the focus round which it revolves.

*Eclipse*, a deprivation of the light of the sun, by the interposition of the moon; or of the light of the moon, by the interposition of the earth.

*Ecliptic*, a great circle in the heavens through which the sun apparently makes its annual revolution; but which is in reality the earth's path round the sun. It makes an angle with the equator of 23 degrees, 25 minutes.

*Elongation*, the annular distance of a planet from the sun, as it appears from the earth. It is applied only to the inferior planets, Mercury and Venus.

*Emersion*, the re-appearance of a celestial body after having been eclipsed.

*Equation* of time, the difference between real and apparent time, or between that shown by a true clock and a sun-dial. It depends on the obliquity of the ecliptic, combined with the unequal motion of the earth in its orbit.

*Equator*, or a great circle of the earth which separates the northern from the southern hemisphere. When referred to the heavens, it is called the *Equinoctial*.

*Equinoxes*, two opposite points in Aries and Libra, where the ecliptic cuts the equinoctial. When the sun is in these points the days and nights are equal to each other.

*Foci* of an ellipse, two points in the longest, or

transverse axis, on each side of the center; from each of which if any two lines be drawn to meet each other in the circumference, their sum will be equal to the transverse axis.

*Galaxy*, or the Milky Way, a luminous and irregular zone which encompasses the heavens, which is found to be composed of an immense number of stars.

*Geocentric* place of a planet, is that position which it has when seen from the earth.

*Gibbous*, a term used in reference to the enlightened part of the moon, from the first quarter to the full, and from the full to the third quarter.

*Gravity* or *Gravitation*, that force by which all masses of matter tend toward each other.

*Halo*, a luminous circle round the body of the sun, or moon.

*Helical* rising of a star, is when it emerges from the sun's rays, and appears above the horizon before him in the morning.

*Helical* setting of a star, is when it is so hid in the sun's beams as not to be seen above the horizon after him in the evening.

*Heliocentric* place of a planet, is that in which it would appear to a spectator placed in the sun.

*Hemisphere*, the half of a globe or sphere.

*Heteroscii*, a name given to the inhabitants of the temperate zones, because their shadows at noon always fall one way.

*Horizon* (the sensible), a circle which separates the visible from the invisible hemisphere, and forms the boundary of our sight.

*Horizon* (the rational), a great circle which is parallel to the former, and whose poles are the zenith and the nadir.

*Hour circles*, the same as meridians—marking the hours.

*Immersion*, the moment when an eclipse begins, or when a planet enters into the shadow of the body that eclipses it.

*Inclination*, the angle which the orbit of one planet makes with that of another, or with the plane of the ecliptic.

*Inferior planets*, those that move at a less distance from the sun than the earth, which are Mercury and Venus.

*Latitude* of a place, its distance from the equator, reckoned in degrees and minutes upon the arc of a great circle.

*Latitude* of a star, or planet, is its distance from the ecliptic, reckoned in degrees, etc., on the arc of a great circle.

*Lesser Circles* of the sphere, those whose planes do not pass through the center, and which divide the sphere into two unequal parts. *Great circles*, as the equator, meridians, etc., divide the sphere into two equal parts.

*Libration* of the moon, an apparent irregularity in her motion on her axis, by which we sometimes see more than the usual half of her disc.

*Longitude* of a place, its distance east or west from the first meridian, reckoned in degrees, etc., upon the equator.

*Longitude* of a star or planet, its distance from the first point of Aries, reckoned in degrees, etc., upon the ecliptic.

*Lunation*, the time between one new moon and another; which is, on an average, 29 days, 12 hours, 44 minutes, 3 seconds.

*Macule*, dark spots which appear on the face of the sun; and *Faculae* are bright spots sometimes seen on the solar disc.

*Magellanic clouds*, certain whitish appearances in the heavens, in the southern hemisphere, supposed to consist either of an immense number of stars, or nebulae.

*Magnitudes*, the stars are divided into six classes; the brightest are called stars of the first magnitude; the next in brightness, the second magnitude, etc.

*Mean motion* of a planet, that which would take place if it moves in a perfect circle, and equally every day.

*Meridian*, a great circle of the sphere which passes through the zenith and the poles, and perpendicular to the horizon.

*Micrometer*, an instrument fitted to a telescope to measure very small angles; as the diameters of the planets, etc.

*Nadir*, that point in the heavens directly opposite to the zenith, or immediately under our feet.

*Nebulae*, luminous spots in the heavens, or clusters of small stars, discovered by the telescope.

*Nocturnal arc*, that space of the heavens which the sun apparently describes from the time of his setting to his rising.

*Nodes*, two points when the orbit of the moon, or of a planet, intersects the plane of the ecliptic.

*Nucleus*, a term used to denote the head of a comet.

*Oblique ascension*, an arc of the equinoctial contained between the first degree of Aries, and that point of it which rises with the center of the sun or star.

*Oblique sphere*, that position of the globe in which either of the poles is elevated above the horizon any number of degrees less than ninety.

*Occultation* is when a star, or planet, is hid from our sight by the interposition of the moon or some other planet.

*Opposition*, an aspect of the stars or planets when they are 180 degrees distant from each other, marked thus  $\oslash$

*Orbit*, the curve which a planet describes in its revolution round the sun.

*Parallax*, the difference of the place of any celestial object, as seen from the surface of the earth, and from its center.

*Parallax of the earth's annual orbit*, the angle at any planet subtended by the distance between the earth and the sun.

*Parallels of latitude*, small circles of the sphere which are drawn parallel to the equator.

*Penumbra*, a faint shadow observed between the perfect shadow and the full light in an eclipse.

*Perigee*, that point of the solar and lunar orbit which is nearest the earth.

*Perihelion*, that point of the orbit of a planet nearest the sun.

*Periscii*, the inhabitants of the frigid zones, because their shadows go around them for six months, or fall toward opposite points of the compass.

*Phases*, the different appearances of the illuminated parts of the moon, or planets.

*Phenomenon*, any extraordinary appearance in the heavens; as a comet, etc.

*Planetarium*, an astronomical machine for showing the motions and other phenomena of the planets.

*Pleiades*, or the seven stars, an assemblage of stars in the constellation of Taurus.

*Polar circles*, two small circles, 23 degrees and a half from the poles; the arctic in the north and the antarctic in the south.

**Pole star**, a star of the second magnitude in the tail of the Little Bear; so called, because it is near the north pole.

**Precession of the equinoxes**, a slow motion of the two points where the equator intersects the ecliptic, which go backward about 50 seconds in a year.

**Quadrant**, the fourth part of a circle; or an instrument for measuring angles, and taking the altitudes of the sun and other heavenly bodies.

**Quadrature**, the position of the moon when distant 90 degrees from the sun; as in the first and third quarters.

**Refraction**, the bending of the rays of light in passing through the atmosphere, by which the heavenly bodies appear more elevated than they really are.

**Retrograde**, an apparent motion of the planets, in some parts of their orbits, when they seem to go backward, or contrary to the order of the signs.

**Right ascension** is that degree of the equator which comes to the meridian with the sun, moon, or star, reckoning from the first point of Aries.

**Rotation**, the motion of any heavenly body round its axis.

**Satellites**, secondary planets or moons, which revolve round the primary planets.

**Sextile**, an aspect of the heavenly bodies, when they are 60 degrees distant from each other.

**Sidereal**, of or belonging to the stars.

**Solstitial points**, the first degree of Cancer and Capricorn at which the ecliptic touches the tropics.

**Selenography**, a representation of the moon, with a description of her different spots and appearances.

**Sign**, the twelfth part of the ecliptic, or 30 degrees.

**Sphere**, the concavity of the heavens in which the stars appear.

**Superior planets**, those which move at a farther distance from the sun than the earth; as Mars, Jupiter, etc.

**System**, a number of bodies revolving round a common center, as the planets round the sun.

**Syzygy**, a term usually applied to the moon, when in opposition, or in conjunction, or when at the new or full.

**Telescope**, an optical instrument for the purpose of viewing distant objects, particularly the sun, moon, planets, and stars. Telescopes produce their effects either by refraction through glasses, or reflection from speculums.

**Telescopic stars**, those stars which are only visible by means of Telescopes. All stars beyond those of the sixth magnitude are reckoned telescopic stars.

**Torrid zone**, that part of the earth which is contained between the two tropics.

**Trajectory**, a term applied to the orbit of a comet.

**Transit** of a planet denotes its passing over another planet, or star, or across the disc of the sun.

**Trine**, an aspect of the planets when they are 120 degrees distant from each other.

**Tropics**, two circles parallel to the equator, and 23 degrees 28 minutes distant on each side of it. They are named Cancer on the north, and Capricorn on the south.

**Vector Radius**, a line supposed to be drawn from any planet to the sun, which, moving with the planet, describes equal areas in equal times.

**Vertical circles**, the same as azimuth circles, or such as are drawn perpendicular to the horizon.

**Prime vertical**, is that azimuth circle which passes through the east and west points of the horizon.

**Year** (the solar), the time which the sun takes to pass from one tropic until it returns to the same again, and is 365 days, 5 hours, 48 minutes, 49 seconds.

**Year** (sidereal), the time which the sun takes to pass from any fixed star to the same again, and is 365 days, 6 hours, 9 minutes, 9 seconds.

**Zenith**, that point of the heavens immediately over head.

**Zodiac**, a zone surrounding the heavens, 18 degrees broad, in the middle of which is the ecliptic. The orbits of all the old planets are included in this zone.

**Zodiacal light**, a brightness sometimes observed in the heavens, somewhat similar to the Milky Way.

**Zone**, a division of the sphere between two parallels of latitude. There are five zones; one torrid, two temperate, and two frigid.

## IV.

## THE TELESCOPE.

As those who have acquired a taste for celestial observations, may wish to know something respecting the telescope, we subjoin the following very brief description.

There are two kinds of telescopes generally distinguished,—the refracting and the reflecting telescope, the former composed of lenses, or convex glasses, and the latter of speculums or mirrors combined with lenses. A common refracting telescope, for viewing some of the celestial bodies, may be constructed as follows:—Procure a convex glass, whose focal distance is about three feet. This may be known by holding the glass in the sun's rays, and measuring the distance between the glass and the place where the solar rays are condensed into a small spot. Place this lens at the end of a tube about three feet two inches long, in which there is a small sliding tube for fixing the eye-glass, and adjusting the focus for distinct vision. At the distance of three feet one inch, place a convex glass one inch focal distance. The object-glass will form a picture, in its focus, of all the objects which are directly opposite to it, and this picture will be seen magnified in looking through the eyeglass. The magnifying power, in this case, will be in the proportion of three feet, or thirty-six inches to one inch; that is, the instrument will magnify the diameters of all objects thirty-six times, or make them appear thirty-six times nearer than when viewed by the naked eye; but as the image formed by the object-glass is in an inverted position, all terrestrial objects will appear through it as turned upside down. The opening at the object-glass which lets in the light, should not exceed an inch in diameter.

With such a telescope, which may be constructed for five or six shillings, if the tubes be made of paper or pasteboard, the satellites of Jupiter, the crescent of Venus, the solar spots, and the inequalities on the surface of the moon may be distinguished. Galileo's telescope, with which he made the first discoveries in the heavens, did not magnify more than such a telescope.





THE

A T M O S P H E R E

AND

A T M O S P H E R I C A L P H E N O M E N A :

ITS NATURE, PROPERTIES, ETC.



# C O N T E N T S

## PART I.

PAGE.

THE NATURE, PROPERTIES, AND BENEFICIAL EFFECTS OF THE ATMOSPHERE IN THE SYSTEM OF NATURE, AND THE EVIDENCES WHICH ITS CONSTITUTION AFFORDS OF THE WISDOM AND BENEFICENCE OF THE CREATOR.

### I N T R O D U C T I O N .

The works of God deserve our serious contemplation. His wisdom displayed in the various scenes connected with sublunary nature. His power displayed in the luminaries of heaven. His perfections manifested even in the invisible regions of nature. Atmosphere an important appendage to our globe. Outline of subjects in reference to the atmosphere..... 7

### C H A P T E R I.

Proofs that air is a material substance. Various experiments illustrative of this position. It produces sound, and shows a resistance to bodies passing through it. It excludes all other bodies from the place it occupies. A common bellows shows the materiality of air. Its waves frequently become an object of sight..... 9

### C H A P T E R II.

The weight and pressure of the atmosphere, and the quantity of matter it contains. Comparative weight of air and water. Experiments illustrative of its pressure. Barometer, and the mode of its action. Pascal's celebrated experiment with water and wine, to prove the pressure of the atmosphere. Remarks and reflections in reference to such experiments. Atmospheric pressure on the body of a man. This pressure varies. Weight of the whole atmosphere. Air decreases in density as we ascend to the higher regions. Scenes beheld from balloons. The pressure of the atmosphere illustrated by a great variety of simple experiments..... 10

### C H A P T E R III.

Facts illustrated by the pressure of the atmosphere. It explains suction. The process of a child sucking the breast. Why two smooth surfaces adhere with great force. Action of a boy's sucker. Adherence of shellfish to the rocks on which they are found. Why frosts occasion a scantiness of water. Why a cask will not run unless open at top. Mode of taking a draught of water, and the principle on which it depends. Action of the syphon. Remarks and reflections in reference to the atmospheric pressure. Its discovery struck the learned throughout Europe with surprise. Amazing pressure on the human body. How our dwellings are prevented from being crushed to atoms. Wisdom and benevolence of the Divine Being in such operations..... 14

### C H A P T E R IV.

The elasticity of the air, and the phenomena it explains. Important purposes effected by the atmosphere. Various illustrations of the elasticity of air. Effects produced in various substances by this property. Spring of the air equal to its weight—is susceptible of dilatation and compression. Elasticity of air not capable of being destroyed. This property explains a great variety of appearances in nature and art..... 16

## CHAPTER V.

The height of the atmosphere, or the elevation to which it extends beyond the surface of the earth—height of the atmosphere, were it of uniform density—its height, as ascertained from the twilight—mode of finding its height from the effects of refraction—probably extends to a much higher elevation than is generally supposed. Height of fire-balls, and other meteors. Universal space may be filled with ethereal fluids..... 1

## CHAPTER VI.

The composition of the atmosphere—atmosphere a compound fluid—history of this discovery—component parts of which it consists. Properties of oxygen gas. Properties of nitrous oxide—its extraordinary effect on the animal spirits, illustrated in a variety of instances—its singular effects on a student in Yale College—its effects on the author, and other individuals—on insects, etc. Reflections on this subject. Properties of nitrogen gas. Carbonic-acid gas—where found—its specific gravity—fatal to all animals that breathe it—*Grotto del Cani*—hints and cautions in reference to avoiding the pernicious effects of this gas. Atmosphere of our globe not to be considered the same as those of other planets—adapted only to mortal men—may be improved, and rendered more salubrious, by the universal cultivation of the soil. Millennial era. Man has it in his power to effectuate important changes, were his moral dispositions renovated. State of the atmosphere before the deluge. Atmospheres of other planets. Reflections..... 20

## CHAPTER VII.

The beneficial effects of the atmosphere in the system of nature. Air is essential to the growth of plants. Pressure of the atmosphere preserves water in its liquid state—supports fire and flame—respiration of all animals depends upon it. Various interesting experiments in relation to respiration. Reflections. Respiration in fishes. Atmosphere essential to the process of evaporation. Density of the atmosphere gives buoyancy to the clouds—is the source of winds, which are of essential use in the system of nature. Air is the vehicle of smell, the medium of sounds; and produces all the harmonies of music—the cause of that splendor and universal light around us, and of the morning and evening twilight. Disastrous effects which would follow were the atmosphere swept away. Divine wisdom and beneficence displayed in the arrangements of the atmosphere—its transparency—not capable of being frozen—man has acquired a certain degree of sovereignty over it. Moral reflection in reference to this subject..... 24

## CHAPTER VIII.

The wisdom and benevolence of the Creator, as displayed in the constitution of the atmosphere. Wisdom and goodness are manifest in the proportion which subsists between the different gases—in determining the relative specific gravity of these gases—and in the process for supplying the waste of oxygen, and promoting the renovation of the atmosphere. Concluding reflections. Folly of denying the reality of a future and invisible state of existence. Many of the objects of religion lie beyond the range of our corporeal vision, but are not, on that account, to be considered unreal. What ought to be our great object in our study of the sciences, and the investigation of the phenomena of nature?..... 31

## PART II.

## ATMOSPHERIC PHENOMENA.

## CHAPTER I.

## AQUEOUS METEORS.

1. Evaporation—Bishop Watson's experiments on this subject—various facts in relation to this process. Quantity of water annually evaporated from our globe.
2. Clouds—their height, size, etc.—Classes into which they have been arranged, cirrus, stratus, cirro-cumulus, nimbus, etc. Electrical clouds, and the ravages they sometimes produce.
3. Rain—imperfect knowledge of its cause—quantity which falls in different seasons, and in different

regions—prognostics of rain—uses of rain. 4. Snow—how formed—its flakes assume regular figures—representation of some of these figures. Avalanches, and the ravages they produce. Uses of snow. 5. Hail—storms of hail in different countries, and the effects they produce—hail-rods for preventing the formation of hail-showers. 6. Dew—its formation. Hoar-frost. Fogs.. 34

## CHAPTER II.

### WINDS.

1. Winds in general explained. 2. General or permanent winds. Trade-winds. 3. Periodical winds, or monsoons. 4. Land and sea-breezes. 5. Variable winds. Destruction occasioned by stormy winds. 6. Noxious and poisonous winds—the harnattan—sirocco—samiel—the simoon—hurricanes—tornadoes. Reflections in reference to noxious winds. Velocity of winds. Uses of winds..... 39

## CHAPTER III.

### LUMINOUS AND FIERY METEORS.

1. The *Aurora Borealis*—its general appearances. Description of several striking auroras. Their appearance in the polar regions. Their supposed cause. 2. *Luminous arches*—their phenomena and elevation. 3. *Fire-balls*—description of their phenomena, size, motion, etc. 4. *Shooting, or falling-stars*. November meteors—their striking appearance in the United States, in 1833—their supposed origin. 5. *Parhelia*, or mock-suns—their general appearance—description of one seen at Rome, illustrated with a figure. 6. *Thunder and lightning*—description of a thunder-storm, with its accompaniments—how to estimate the distance of a thunder-cloud. Different kinds of lightning. Identity of lightning and electricity. Thunder-guard. **Maxims to be observed during a thunder-storm. Concluding reflections.....** 49



# THE ATMOSPHERE

AND

## ATMOSPHERICAL PHENOMENA.

### PART I.

THE NATURE, PROPERTIES, AND BENEFICIAL EFFECTS OF THE ATMOSPHERE  
IN THE SYSTEM OF NATURE, AND THE EVIDENCES WHICH ITS CONSTITUTION  
AFFORDS OF THE WISDOM AND BENEFICENCE OF THE CREATOR.

### INTRODUCTION.

ALL the works of God, throughout the immensity of the universe, display the character, perfections, and agency of the Supreme Creator, to every rational and Christian mind that surveys them with attention and intelligence. From the magnificent luminaries of heaven to the comparatively small globe on which we dwell, and the smallest microscopic animalcule that glides through its waters, we perceive the impress of omnipotence and skill, which infinitely surpass all the puny labors and inventions of man. These works were evidently intended by their Divine Author to be investigated, contemplated, and admired by all his intelligent offspring, that their conceptions of the Divine character may be expanded, and that they may be led to give unto Him "the glory due unto his name." The enlightened Christian, therefore, ought to devote a portion of his time and attention to the study and contemplation of the works of God, not only as a rational amusement, but as a solemn duty: for, in numerous passages in the sacred records, this duty is expressly inculcated: "Lift up your eyes on high, and behold who hath created these things."—"Stand still, and consider the wondrous works of God"—"The works of the Lord are great, sought out of all them that have pleasure therein"—"Great and marvelous are thy works, Lord God Almighty."

When we look around on the surface of the earth, and behold the beautiful and sublime landscapes which diversify its aspect, the variety of colors with which it is adorned, the myriads of trees, shrubs, and flowers which spring from its surface, and the rich perfumes they shed around them—the numerous animated beings which traverse the air, the ocean, and the earth, and the ample provision which is made for their subsistence and comfort—we can scarcely fail of being impressed with the conviction, that the Creator is a being of unbounded beneficence, that "His tender mercies are over all his works," and that the happiness of his sensitive and intelligent offspring is one great end of all his arrangements. When we consider the curious and exquisite

structure of all the vegetable tribes, the numerous vessels with which they are furnished, the thousands of delicate tubes, invisible to the naked eye, through which their sap and juices are continually flowing to the leaves and branches, the millions of pores through which they shed their delicious odors, and the curious texture and the numerous beauties which the microscope alone can discover in their leaves, prickles, stamens, petals, and flowers:—when we consider the numerous orders of animated beings—the wonderful diversity of structure they exhibit, in their eyes, ears, feet, joints, claws, wings, and movements—their numberless contrivances, which enter into their construction and functions—the thousands of adjustments, adaptations, borings, clasplings, and polishings, which enter into the body of an animal a thousand times less than a mite—the adaptation of all these contrivances to the purposes of life, motion, and enjoyment, and their correspondence to the surrounding elements in which such creatures pass their existence:—and, in particular, when we contemplate the structure and functions of our own corporeal frames; the hundreds of bones of different shapes and sizes which support it; the hundreds of muscles of different conformation, which give motion to its different parts; the thousands of glands, secreting humors of various kinds from the blood; the thousands of lacteal and lymphatic tubes, absorbing and conveying nutriment to the circulating fluid; the millions of pores, through which the perspiration is continually flowing; the infinite ramification of nerves, diffusing sensation throughout all the parts of this exquisite machine; and the numerous veins and arteries which convey the whole mass of blood through every part of the body ten times every hour:—when we consider these adaptations and arrangements throughout the vegetable and animal kingdoms, we perceive the marks of a Divine intelligence and skill, which completely throw into the shade the most exquisite contrivances of human genius, and which convince us that the wisdom of the Creator is infinite, and "his ways past finding out."

In short, when we lift our eyes beyond the boundaries of the globe on which we dwell, and look upward to that boundless firmament where suns unnumbered shine, and planets and comets run their ample rounds—when we behold ten thousand times ten thousand of luminous and opaque globes of vast dimensions scattered in magnificent profusion throughout every region of infinite space; when we contemplate the sun occupying a space which would hold one million three hundred thousand worlds such as ours; and when we contemplate globes fourteen hundred times larger than our world, flying through the voids of space with a velocity of thirty thousand miles an hour, and carrying along with them in their rapid career a retinue of surrounding worlds—we behold the effects of a Power which all the subordinate intelligences in the universe can never control, a power before which the mightiest achievements of human art sink into the same scale with the flutterings of a microscopic animalcule; a power which astonishes and confounds the imagination, which sets at defiance human calculations, but which conveys to the mind a most impressive idea of the grandeur of the Divine Being, and of the magnificence of that universe which his hands have formed!

It is not merely in the scenes of the visible world that the attributes of Deity are conspicuously displayed. Even in the invisible regions of creation, which are impalpable to the organs of human vision, the perfections of the Eternal Mind are no less apparent to the philosophic and Christian inquirer, than in those external scenes of beauty and magnificence which arrest the attention of every spectator. Could we descend to the central regions of our globe, and contemplate the processes which are going on in those unexplored and unexplorable recesses; could we penetrate into the depths of the ocean, and survey the multiplicity of objects which lie concealed in its unfathomable caverns; could we ascend on the wings of the wind with the vapors which rise from its surface, and contemplate all the regions and transformations through which they pass, until they again descend in refreshing rains on the mountains and vales; could we wing our flight beyond the denser regions of the atmosphere into those places where fire-balls and shooting stars have their origin, and where the aurora borealis displays its fantastic coruscations; could we ascend to the ethereal spaces which intervene between us and the celestial bodies, and investigate those apparently empty regions which surround the atmospheres of all the planets; or, could we penetrate into the chemical processes and changes which are incessantly going on among the invisible atoms of matter, in the union and disunion of the different gases, in the various modifications of crystallization, in the circulation of the sap and juices in the minutest flowers, and in the internal vessels of microscopic animalcules;

we should doubtless behold the operations of a Wisdom and Intelligence no less admirable and astonishing than what is displayed in the visible scenes of nature which are obvious to every eye.

Of those invisible regions of nature now alluded to, the ATMOSPHERE is one in which we are particularly interested, and which exhibits a striking scene of Divine wisdom and beneficence.

The term atmosphere may be defined to be “that body of air, vapors, electric fluid, and other substances which surround the earth to a certain height.” This mass of fluid matter gravitates toward the earth, presses upon its surface with a certain force, revolves with it in its diurnal rotation, and is carried along with it in its course round the sun, at the rate of sixty-eight thousand miles an hour. This fluid mass is invisible to the corporeal organs; and hence, the great body of mankind are apt to imagine that the regions around us, in which the birds fly, and the clouds move, are nothing else than empty space; and, were it not that they sometimes hear its sound in the breeze, and feel its effects in the whirlwind and the storm, they would be disposed to deny that such a thing as the atmosphere had an existence. There is, however, no appendage to our globe which is so essentially requisite to the comfort, and even to the very existence of animated beings; for, were the earth and the ocean, the springs and the rivers, to remain as they now are, but were the hand of Omnipotence to detach from our globe the atmosphere with which it is now environed, it is absolutely certain that, in a few minutes, and after a few sighs and groans, all the eight hundred millions of men that now people the earth, and all the other animated beings that traverse the air, the waters, and the land, would sink into the slumbers of death, and disappear forever from the living world.

In elucidating this subject, the observations that will be made may be arranged under the following heads:—

- I. To prove that air exists, and that it is a material substance.
- II. To consider its weight or gravity, and the force with which it presses on all bodies on the surface of the earth.
- III. To exhibit several facts which the pressure of the atmosphere tends to illustrate.
- IV. To illustrate the elasticity of the air, and the effects it produces.
- V. To offer some considerations for illustrating the height of the atmosphere, or its elevation above the surface of the earth.
- VI. To illustrate its composition; or, the chemical principles of which common atmospheric air is composed.
- VII. To illustrate its beneficial effects in the system of nature.
- VIII. To exhibit the evidences which its constitution affords of the wisdom and benevolence of the Creator.



## CHAPTER I.

### AIR IS A MATERIAL SUBSTANCE.

The first inquiry, then, is, What is that air, of the importance of which we hear so much asserted? We see nothing, it may be said—we feel nothing. We feel ourselves at liberty to move about without any let or hindrance. Whence, then, the assertion that we are surrounded by a substance called air? A few facts and illustrations only will be sufficient to elucidate this position.

1. If we take a rod, and make it pass rapidly through what appears empty space, we shall hear a sound and feel a slight resistance, as if something had intervened to prevent the motion of the rod.

2. If we take a large fan, or an umbrella, when fully stretched, and push it forcibly from us, we shall feel a very considerable resistance, and a person opposite will feel a certain impression made upon his face, as if some substance had come in contact with it. Were we to take a very large umbrella—say from twelve to fifteen feet diameter—and stand on the top of a high stair, or a building, twenty or thirty feet high, we might jump from such a position, while we hold it fully stretched, and gradually descend to the ground without violence or injury. It is on this principle that the instrument called a parachute is constructed, by means of which an aeronaut, while pursuing his aerial excursions, has left his balloon, when elevated nearly a mile above the surface of the earth, and descended in a few minutes to the ground, without shock or accident. Perhaps some contrivance of this kind might be useful to prevent accidents in the case of fires in large towns—when persons have attempted to jump from the windows of a third story to preserve themselves from being involved and destroyed in the burning mass. The circumstances now stated prove, that there is a certain material substance, though invisible, around us, which offers a sensible resistance to any body having a large surface when it is pushed rapidly through it.

3. That air is a material substance, appears from its excluding all other bodies from the place it occupies. Thus, if we take a glass jar, and plunge it with its mouth downward into a vessel of water, only a very small quantity of water will get into the jar, because the air, of which the jar is full, keeps the water out; otherwise, if it were empty of every material substance, the water would rush in and completely fill the jar. Hence, we may learn why a vessel cannot be filled with water by plunging its orifice downward, and why a funnel, if its pipe fit closely to the neck of a bottle, is not convenient for pouring off liquors; for, in order to put water or wine into a bottle, the air must pass between the neck of the bottle

and the funnel, to let the air out as the water rushes in. And hence, the practice in such cases, suggested by necessity, of pulling up the funnel a little when the liquor stops, in order to let the air rush out between the pipe and the neck of the bottle. It is on the principle now stated, that the diving-bell is constructed, by which a person may descend to a considerable depth into the sea, and yet not be immersed in water, nor deprived of air for breathing.

4. If we take a smooth cylindrical tube shut at one end, and fit a plug or cork exactly to its open end, so as to slide along it, if the plug be so tight and soaked with grease, as to prevent all passage of any fluid by its sides, we shall find that no force whatever can push it to the bottom of the tube. There is, therefore, something within the tube, though invisible, which prevents the entry of the plug, and, therefore, possessing the characteristic of matter, and this something is air.

5. Let us take a pair of common bellows, and, after having opened them, if we shut up the nozzle and valve-hole, and try to bring the boards together, we shall find it impossible. There is something included that prevents this, in the same manner as if the bellows were filled with flax or wool; but, on opening the nozzle, we can easily shut them by expelling this something that is within, which will issue with considerable force, and impel anything that lies in its way. This something can be nothing else than the air of the atmosphere.

6. The air, though for the most part invisible, may, in certain cases, be rendered an object of sight. If we take a telescope of high magnifying power, and, in the forenoon of a hot summer day, when the sun is shining, look through it to distant objects, we shall perceive the air undulating about the objects somewhat like the waves of the sea, and rendering them undefined and obscure. This is the principal reason why very high magnifying powers cannot be used, with effect, on telescopes for land objects, in the day-time, when the sun produces undulations in the atmosphere; and the same cause frequently prevents distinct vision of celestial objects.

The above are clear proofs that the air, though not generally an object of sight, is, in reality, a material substance, as much so as water, wood, stones, or iron. This substance, in a state of rest, we call air; in a state of motion, we call it wind; and, in this state, its force is sometimes so great as to drive our wind-mills, impel our ships across the ocean, and even to overturn buildings, to tear up from their roots the largest trees, and to dash whole fleets to pieces of wreck.

## CHAPTER II.

### THE WEIGHT OF THE ATMOSPHERE, AND THE QUANTITY OF MATTER IT CONTAINS.

AS AIR is demonstrated to be a body, like all other material substances, it must have weight, and the proportion its weight bears to other known substances is determined by experiment. If a bottle which contains about a quart be emptied of its air by means of an air-pump, or in any other way, and then accurately weighed in a nice balance, it will be found to be about sixteen grains lighter than it was before it was emptied of its air, which shows that a quart of air weighs sixteen grains. A quart of water weighs about 14,620 grains, or nearly two pounds. If this last number be divided by sixteen, the quotient will be nine hundred and thirteen, which shows that air is nine hundred and thirteen times lighter than water; or, in other words, that it would require above nine hundred quart-bottles of air to weigh one quart-bottle of water. Other experiments which have been made to determine this point, lead to the result that for every cubic foot of air, five hundred and twenty-three grains, or, one and one-fifth ounce avoirdupois, are to be allowed; and, since a cubic foot of water weighs 1,000 ounces, the one divided by the other gives a result of eight hundred and thirty-three, the number of times that water is heavier than air. It is impossible to arrive at very great nicety in such estimates; but the general results of all the experiments which have been made on this point, lead to the conclusion that air is somewhere between eight hundred and nine hundred times lighter than water. These results, however, must be understood solely to apply to the air near the surface of the earth; for, as we ascend into the higher regions of the atmosphere, the air becomes gradually thinner and lighter, being less pressed with the air that is above.

We may now attend to the pressure which the atmosphere exerts upon the surface of the earth, and upon all bodies connected with it.

It has been proved by a variety of accurate experiments, that the atmosphere presses on every part of the earth's surface with a force, at an average, equal to about fifteen pounds on every square inch. This has been ascertained by what is called the Torricellian experiment. Take a glass tube about three feet long, open at one end, and hermetically sealed at the other: fill it with quicksilver, putting the finger upon the open end, turn that end downward, and immerse it in a small vessel of quicksilver, without admitting any air, then take away the finger, and the quicksilver will remain suspended in the tube about twenty-nine and a half inches above its surface in the vessel, sometimes more and sometimes less, according to the state of the atmosphere. It is evident, then, that the quicksilver is kept up in the tube to this elevation by the pressure of the atmosphere upon the surface of the mercury in the basin; for, if the basin and tube are put under a glass, and the air extracted, all the quicksilver in the tube will fall down into the basin; and, if the air be readmitted, it will rise to the same height as before;

or, if an opening be made in the top of the tube and the air admitted, the quicksilver will sink into the basin. The pressure, therefore, by the atmosphere on the earth, is the same as if a coating of quicksilver twenty-nine and a half inches thick were spread over every part of the earth's surface.

Now, it is proved that a square column of quicksilver twenty-nine and a half inches in height, and one inch thick, weighs just fifteen pounds, which counterpoises a column of air of the same thickness, extending to the top of the atmosphere; and, consequently, that air presses with this force upon every square inch of the earth's surface; and, of course, 2160 pounds on every square foot, and 19,440 on every square yard. The experiment now described is, in fact, nothing else than the common barometer. The tube of the barometer is filled with quicksilver, or mercury; it then stands in a basin of quicksilver, is connected with a ball containing quicksilver, on the surface of which the atmosphere presses, and, in most cases, stands at an elevation of about twenty-nine and a half inches, but subject to certain variations, according to the state of the atmosphere. When the weather is steady and serene, it rises to above thirty inches; when it is stormy and rainy, it frequently sinks to twenty-eight inches, or under, thus indicating the changes that take place in the weight of the air; and hence it has obtained the name of the weather-glass.

Were the same experiment made with water, instead of mercury, a tube must be provided of about thirty-six feet long; and then it would be found, that the water in the tube would be supported by the atmospheric pressure to the height of thirty-two or thirty-three feet. This costly experiment, which has been seldom repeated, was first performed by the celebrated Pascal, at Rouen, in Normandy, in 1647. He exhibited the experiment both with water and with wine, in order to show the different heights to which these fluids would rise, according to their respective densities. He procured, at a glass-house, tubes of crystal glass forty feet long, which were fixed to the mast of a ship, that was contrived to be raised or depressed, as occasion required. He appointed a day for performing this experiment, and invited all the philosophers and others who doubted of the pressure of the atmosphere to attend, and to be witnesses of the wonderful nature of his experiment. The result was, according to the calculations he had previously made, that the altitude of water in the tube was thirty-one and one-ninth Paris feet, equal to thirty-two feet two and a half inches English; and the altitude of the wine was somewhat greater, namely, thirty-one and two-thirds Paris feet, or thirty-two feet ten inches English; the wine, on account of its superior levity, rising about seven and a half inches higher than the water. He performed this experiment to convince the Aristotelian philoso-

phers of those times of the folly of a notion which then prevailed, that the rise of the mercury in the Torricellian experiment and the rise of water in pumps were produced, not by the pressure of the atmosphere, but by an occult quality, which they denominated "Nature's abhorrence of a vacuum." They asserted that, in the upper part of the tube, deserted by the quicksilver, there were contained some *spirits*, evaporated from the quicksilver; which, being rarefied, filled up that space, thus assisting Nature, in a great emergency, against her mortal enemy, a vacuum. "Well, then, gentlemen," says Pascal, "take your own way. Here are two tubes, the one I am to fill with water, and the other with wine. You will all readily admit that there is a greater quantity of spirits in wine than in water; and, consequently, that if the empty space between the upper surface of the fluids and the top of the tube be filled with spirits, there will be a greater quantity of spirits, in the upper part of the tube containing the wine than in the tube containing the water; and, of course, the wine will not rise so high as the water." To this they all readily assented. But, when the experiment was made, the wine was found to rise nearly eight inches higher than the water, as Pascal had previously calculated and predicted. This experiment was decisive; and, since that period, the figment of "Nature's abhorrence of a vacuum," along with many other absurdities, has been consigned to the slumber of the dark ages whence it originated.

A few years before the period now alluded to, the engineers of the Grand-duke of Florence, having received orders to raise a portion of water to the height of fifty or sixty feet, by means of a common pump, perceived, when they had made the attempt, that the pump refused its assistance when the water was to be raised above thirty-two feet. They communicated the circumstance to Galileo, an eminent philosopher of that age, and asked him the reason of it. Galileo was not a little surprised, and was unprovided with an answer. He, however, put a good face on the affair, and gravely replied, that "Nature abhorred a vacuum only to the height of thirty-two feet." Torricelli, the disciple of Galileo, vexed at the water's refusing to ascend more than thirty-two feet in a tube void of air, made a new experiment with quicksilver, in the manner already described. He saw the quicksilver in the tube fall down, and leave an empty space at top, and remain suspended at the height of twenty-nine inches.—"How," says he, "Nature abhors a vacuum only to the height of thirty-two feet when it is water that ascends in a tube void of air, and only to twenty-nine inches when it is mercury! Vacuum does not frighten her beyond these measures! But why does she fear it to far more than twenty-nine inches when it is water that rises? Very likely this horror at vacuity is an idle fancy, a mere philosophical cant, which we take for good coin without understanding it." Reasoning in this way, and repeating a variety of similar experiments, he was, at length, led to the conclusion "that the diversity of the elevation of the two different fluids proceeded from the diversity of their weight, and that they were supported and counterpoised by a column of air, of the same diameter, reaching the top of the atmosphere." Here the matter rests, and will rest throughout all succeeding generations.

This short sketch of the history of the experiments which relate to the pressure of the atmosphere will not be altogether out of place, if it has a tendency to guard us against the influence

of preconceived notions, foolish prejudices, and of the authority of great names, which are some of the greatest obstructions to the expansion of the human mind, and the reception of useful knowledge. It was not before men began to emancipate themselves from such shackles that science commenced that brilliant career which has issued, in our times, in so many interesting and important discoveries. Similar prejudices are still prevalent in relation to the affairs of common life, the facts of science, and the important truths of religion. We are only yet beginning to cast off the yoke of that ignorance, under the guise of wisdom, under which the men of other times bowed with such abject submission. Religious prejudices, in particular, derived from education and submission to mere authority, are frequently so strong that no species of reasoning, however convincing to an unbiased mind, is sufficient to subdue them. When certain dogmas or opinions, however futile, have got a firm hold on the mental faculties, all the arguments that can be derived from reason and philosophy, and even from the most cogent announcements of Divine revelation, are found altogether insufficient to displace them. And, as the fostering of erroneous opinions, in relation to religion, may endanger our best interests, both in relation to the life that now is and the life to come, it is of the utmost importance to all, and especially to young persons, that they examine, with care and without prejudice, every doctrine and opinion they embrace, without regard to human authority; founding all their views and sentiments on the dictates of enlightened reason, and the plain declarations of the word of God.

From what has been now stated, we may easily compute the weight sustained by the body of a middle-sized man, in consequence of the pressure of the atmosphere. Suppose the average stature of the human body to be about five feet nine inches; suppose the breadth in front to be about one foot, and the breadth on each side half a foot; by allowing a little deduction for the narrowness of the head and feet, we may reckon about five feet in front, and five for the back part, and two and a half square feet for each side of the body, or fifteen square feet in all. It has already been stated that the atmospheric pressure on one square foot is 2160 pounds. Multiply this sum by fifteen, the number of square feet on the surface of the human body, and the product will be 32,400 pounds, or somewhat more than fourteen tons, or the weight of more than fourteen ordinary cart-loads of heavy goods. This is the pressure sustained by every middle-sized man—a pressure which would be insupportable, and even crush us to pieces, were it not that it is equal in every part; pressing with the same force upward, downward, and on every side; and is at the same time, counterbalanced by the spring of the air within us, which is diffused through the whole body, and reacts with an equal force against the outward pressure. This pressure, however, is somewhat different at different times. When the air is lightest, the pressure is 31.150 pounds, and, when heaviest, about 33,660 pounds, making a difference of about 2500 pounds, the weight with which we are compressed more at one time than at another. This great difference in the atmospheric pressure is found greatly to affect the animal functions and the state of health. A person laboring under an asthmatical complaint will find his disorder increased when the air is light, as it has then less elasticity, and is not so capable of expanding the lungs. The air is gene-

rally the highest in hazy and rainy weather, when the clouds descend, and the mists cover the mountain tops. Every one then feels the effect, by a certain degree of lassitude and depression of spirits, occasioned by the surrounding gloom, and by being deprived of an atmospheric pressure amounting to more than 2000 pounds. The fibers of the body are relaxed, the contractile force of the muscles diminished, and a languid circulation of the fluids ensues, which sometimes produce obstructions, fevers, and headaches; and, in most persons, a sort of indolence and gloomy inactivity. Whereas, when the air is heavy, and the clouds ascend to the higher regions, and appear like fine fleeces on the blue vault of heaven, the nerves and fibers of the animal system are braced by the additional pressure of the atmosphere, the blood-vessels exert their full power, the solids are compressed, the fluids circulate with increased vigor, we feel light and alert, and the elevation of the animal spirits is increased by the splendor and activity of the surrounding scene.

*Weight of the whole Atmosphere.*—From the facts now stated, we may form an estimate of the weight of the whole body of the atmosphere which surrounds the surface of the earth. The surface of the globe contains, in round numbers, 200,000,000 of square miles; every square mile contains 27,878,400 square feet; and these two numbers multiplied together, produce 5,575,680,000,000,000; or, five thousand five hundred and seventy-five billions, six hundred and eighty thousand millions, equal to the number of square feet on the surface of the earth; which multiplied by 2160 pounds (equal to the pressure on every square foot), produces the sum of 12,043,468,800,000,000,000; that is twelve trillions, forty-three thousand four hundred and sixty-eight billions, and eight hundred thousand millions; which is equal to the number of pounds which constitute the weight of the whole atmosphere, or 5,000,000,000,000,000; that is, about five thousand billions of tons. A more definite idea of this weight may be obtained by supposing a ball of lead, extending from London to Oxford, stretching sixty miles perpendicularly above us, and in every direction; or, in other words, a ball of lead one hundred and ninety miles in circumference, and about sixty miles in diameter. Suppose this ball placed on one end of an immense balance, and the whole atmosphere on the other, they would nearly counterpoise each other. So that this invisible fluid, which we are apt to consider as almost a nonentity, when considered as a whole, contains a weight which it is difficult for numbers to express.

It need only be observed further on this point, that the air decreases in density in proportion as we ascend to the higher regions of the atmosphere. At the height of seven miles, the air is four times rarer than at the surface of the earth; at the height of fourteen miles, it is sixteen times rarer; at the height of twenty-eight miles, it is two hundred and fifty-six times rarer; at the height of ninety-six miles, it is 268,435,456 times rarer; and at the height of five hundred miles, it has been computed, that a cubic inch of such air as we breathe at the surface of the earth, would be so much rarefied, that it would fill a hollow sphere equal in diameter to the orbit of the planet Saturn, which is 1,800,000,000 of miles in diameter. This is a necessary consequence of the elasticity of the air, and of its want of compression in the higher regions; and that this is in reality the case, is proved by experiment as well as by calculation. When we

take a barometer to the top of a mountain only half a mile in perpendicular elevation, the mercury falls from thirty to twenty-seven inches; and the fall of the mercury is in proportion the higher we ascend. Those travelers who have climbed to the tops of lofty mountains know, by experience, that the air is much thinner in those regions than in the plains below. Their breathing becomes difficult and painful, their hands and feet swell, and they are sometimes seized with a vomiting of blood. They also find, that the atmosphere becomes clearer as they ascend, and is unable to support the clouds. We are informed by Don Ulloa that, while he stood on the top of the Andes, in Peru, "the clouds, which were gathered below the mountain's brow, appeared like a tempestuous ocean, all dashing and foaming, while the lightnings were breaking through the waves, and the thunders rolling beneath his feet, far below the spot on which he stood. In the meantime he enjoyed a serene and cloudless sky, and left the war of the elements to the unphilosophical mortals on the plains below."

Those who have taken a flight to the higher regions of the atmosphere in balloons, have beheld scenes of a similar kind. Mr. Baldwin, who ascended in a balloon from Chester, in 1785, relates that at a certain elevation, the earth was entirely hid from his view by an immense mass of vapors, which he compares to a sea of cotton, tufted here and there by the action of the air, and, soon after, the whole became an extended pavement of white cloud. The reason of all this is obvious: the clouds are vapor, or water rarefied by heat. Vapor is lighter than air near the surface of the earth, and, consequently, ascends in it; but, in the higher regions, the air is thinner and lighter than these vapors, and, of course, is unable to support them beyond a limited height; which circumstance undeniably proves that the air is lighter the higher we ascend.

The pressure of the atmosphere may now be illustrated by a few simple experiments. The instrument called the air-pump affords, on the whole, the best means of illustrating the pressure of the atmosphere. This instrument bears a certain resemblance, in its principle and action, to the common house pump. It consists of a hollow cylinder or tube, in which a piston is alternately raised and depressed by means of an iron rod attached to the handle of the pump. In the piston there is a valve, which opens by any pressure from below, and is shut by any superincumbent pressure, like the flapper of a pair of bellows. When the piston is forced down, the valve is opened from below by the pressure of air, or whatever fluid the pump may contain. The fluid then gets above the valve, and is lifted up by the raising of the piston, and carried out of the pump, the valve being then shut by the pressure of the air above it. At the top, is a metal plate ground to a perfect plane surface, on which is placed an inverted glass jar or receiver, whence the air is to be extracted. A hole in the plate is connected with a tube which communicates with the pump-barrels. By working the handle of the instrument for some time, the receiver will soon be nearly exhausted of all the air it contains, and the effects produced in a vacuum, or place void of air, may then be exhibited. The following, among other experiments, may be shown by the air-pump. If the receiver be open at both ends, and the upper orifice be stopped by the hand, when the air is exhausted, the pressure of the external air will be such as to prevent the removal of the hand, and will cause a certain degree of pain. If a piece of bladder

be tied tightly over the orifice, as the exhaustion proceeds, the bladder will be pressed inwards, and will finally burst with a loud noise. In the same manner, if a flat piece of window-glass be placed upon the orifice, when the air is exhausted, the glass will be broken into a number of pieces by the external pressure of the atmosphere.

But as comparatively few persons have an opportunity of performing experiments with the air-pump, a few simple experiments equally convincing, which every person has it in his power to perform, may here be described.

1. Take a wine or an ale-glass, and fill it with water; take a smooth piece of writing paper, and press it firmly against the edges of the glass, so that no air get in between the paper and the water, then turn the glass upside down, and the water will be supported by the pressure of the atmosphere upon the paper. That it is the external pressure of the atmosphere upon the paper which supports the water will appear, when we consider that the paper, instead of being convex, by the pressure of the water downward, is concave, by the pressure of the air upward. If a lighted candle be placed under the paper, with its flame touching the paper, we may hold it for an indefinite length of time, without its producing any effect upon the paper, or setting fire to it.

2. Take a wine-glass, and burn a piece of paper in it, and while the paper is burning, if we place the palm of our hand firmly upon the edges of the glass, the glass will stick fast to the hand, producing a certain degree of pain, and it will require a considerable degree of force before the hand can be detached from the glass. In this experiment, the burning of the paper rarefies the air, nearly expels it from the glass, and then the atmosphere presses with its whole weight upon the hand.

3. Take a glass tube two or three feet long, of a narrow bore; plunge one end of it in a basin of water; apply the mouth to the other end, and draw out the air by suction; the water will instantly rise into the tube by the pressure of the atmosphere on the water in the basin; and, if we immediately place our thumb firmly on the upper part of the tube, and withdraw it from the water in the basin, the water will be suspended in the tube by the pressure of the atmosphere, although the tube is open below; but, when the thumb is removed from the upper part of the tube, the water in it will run out, in consequence of the pressure of the atmosphere from above.

4. Take a tin vessel, six or eight inches long, and about three in diameter, with its mouth about a quarter of an inch wide, as *EF* (fig. 1). Pierce

a number of small holes in its bottom, about the diameter of a common sewing-needle. Plunge this vessel in water, and, when full, cork it up, so that no air can enter at the top. While it remains corked, no water will run out, being prevented by the atmospheric pressure upon the bottom of the vessel; but the moment it is uncorked, the water will issue from the small holes by the pressure of the air from above. The same experiment may be made with a tin-plate tube, about an inch in diameter, open at the top, and having its bottom pierced with a small hole. When filled with water and tightly corked at the top, it may be carried for miles without losing a drop of water, notwithstanding the hole in the bottom.

Fig. 1.



Fig. 2.



5. In order to show the lateral pressure of the atmosphere, take a tube, as *GH* (fig. 2), six or seven inches long, having a small hole on each side, as *I* *K*. When filled with water, and tightly corked, no water will run out from the sides of the tube, but the moment the cork is taken out, the water will run out at *I* and *K*, as represented in the figure.

6. Take a wine-glass and burn in it a piece of paper; then invert the glass, while the paper is burning, over a saucer full of water, the water will rush up into the wine-glass, in consequence of the air being rarefied or driven out by the burning paper, and in consequence of the pressure of the atmosphere upon the surface of the water in the saucer.

These experiments show that the atmosphere presses in all directions, upward, downward, and laterally. This subject has been dwelt on somewhat particularly, because the atmospheric pressure forms an important element, and a mechanical power in the construction of steam-engines, atmospheric railways, and other modern inventions, which are now of such great utility in propelling carriages along railways, and steam-vessels across seas and oceans.

## CHAPTER III.

### FACTS ILLUSTRATED BY THE PRESSURE OF THE ATMOSPHERE

LET us now attend to a few facts which the pressure of the air tends to explain and illustrate.

1. The atmospheric pressure explains the nature of the process vulgarly termed suction. When we attempt to take a draught of water out of a basin, or a running stream, it is commonly said that we draw in the water by suction; whereas the fact is, that instead of drawing the water into the stomach, we only draw the air into the lungs, and the atmosphere performs the other part of the operation. The process is simply this:—We immerse our lips into the water, so as to prevent the entrance of air into the mouth; we then make a vacuum in the mouth by drawing the air into the lungs, after which the pressure of the atmosphere upon the surface of the water forces it upward into the mouth. That such is the process of receiving a draught of water when the mouth is held downward, appears from this circumstance, that if the lips do not *touch* the water, we might draw in the air by what is called suction for twenty years, and not receive a single drop into the mouth.

The same principle explains the action of a child sucking the breast of its nurse. The operation of cupping is performed in the same way. In this case the operator takes a small glass, close at the top, and holding it for some time over the flame of a candle or lamp, the air is thereby rarefied, and part of it drawn out. The glass is then suddenly placed on the part of the body to be cupped, and adheres to the flesh by the external pressure of the air. The flesh rises in the glass, and the blood and serosities are forced from the wounded vessels into the glass by the atmospheric pressure on the parts around.

2. It is owing to the atmospheric pressure that two polished surfaces, which accurately fit each other, adhere with great force. This fact is well known to glass-grinders and polishers of marble. A large lens, when ground very smooth, requires more than the strength of a single individual to pull it directly from the tool. If the surface is only a square inch, it will require fifteen pounds to separate them perpendicularly, though a very moderate force will make them slip along each other. Were the surface six inches square, the force requisite to separate the two pieces would be equal to five hundred and forty pounds. But this cohesion is not observed, unless the surfaces are wetted or smeared with oil or grease, otherwise the air gets between them, and they separate without any trouble. That this cohesion is owing to the atmospheric pressure, is evident from the ease with which the plates may be separated in an exhausted receiver by means of the air-pump. The same cause contributes in a powerful degree to give effect to the cohesion of bodies by means of mortar and cements. When two pieces of wood are to be glued together, their surfaces are first made as smooth as possible; a glutinous substance is then applied to fill up all the pores and inequalities; they are then pressed to-

gether, which prevents the air from insinuating itself between them, and the external air then presses upon them with a force of fifteen pounds on every square inch. There can be no question that the stability of our houses and garden walls depends, at least in a great measure, upon the same principles; for the more completely every crevice between the bricks or stones is shut up, by means of mortars and cements, from the insinuation of the external air, the more firm and stable is the building.

To the same cause is to be attributed the action of a boy's sucker in lifting large stones from the ground. The sucker is made of stiff wetted leather fastened to a string; the moisture upon the leather, when it is pressed down upon the stone, prevents the air from getting in between the leather and the stone, and if the sucker be four inches square, it will require a force of two hundred and forty pounds to separate it from the stone. In certain cases, such contrivances, on a large scale, might be sometimes useful as a mechanical power.

3. Another circumstance which is accounted for on this principle is, the strong adhesion of snails, periwinkles, limpets, and other molluscous animals, to the rocks on which they are found. The animal forms the rim of its shell so as to fit the shape of the rock on which it intends to cling. It then fills its shell either with its own body or with water. In this condition, it is evident, that we must act with a force equal to fifteen pounds on a square inch before we can detach it from the rock. This may be illustrated by filling a drinking-glass to the brim with water, and, having covered it with a piece of thin wet leather, place it upon a table, and it will be found to require a very considerable force to pull it straight upward. But, if we place a snail adhering to a stone in an exhausted receiver, it will drop off by its own weight. It is owing to the same cause that bivalve mollusca, such as *oysters* and *mussels*, keep their shells so firmly shut, and require such a degree of force to open them. But, if we grind off a bit of the convex shell, so as to make a small hole in it, the air gets in, and it opens with the greatest ease. The same thing takes place when it is put under the exhausted receiver of an air-pump. It has been lately discovered that it is owing to the same principle that flies and other animals have the power of walking on a perpendicular pane of glass, or on the ceiling of a room, with their backs downward. This has been proved to arise from a power they possess of squeezing out the air between the inside of their feet and the surface on which they tread, and thus being supported against the outside of their feet by the pressure of the atmosphere.

4. It is owing, in a great measure, to the pressure of the atmosphere, that frosts occasion a scantiness of water in our fountains and wells. This is not caused, as is generally supposed, by the freezing of the water in the bowels of the earth. The most intense frost of a Siberian win-

ter would not freeze the ground two feet deep, but a moderate frost will consolidate the whole surface of a country, and make it impervious to the air, especially if the frost has been preceded by rain, which has soaked the surface. When this happens, the water which was filtering through the ground is all arrested, and kept suspended in its capillary tubes by the pressure of the air, in the same manner as water is suspended in a tube which is closed at one end, as in the third experiment stated in the preceding chapter (p. 13). A thaw melts the superficial ice, and allows the water to run out in the same manner as it does when the thumb, in that experiment, is removed from the top of the tube.

5. It is well known that a cask full of water, or spirits, will not run by the cock, unless a hole be opened in the top, or some other part of the cask. The reason is, that the air presses upon the opening in the cock, and prevents the liquor from flowing; whereas, when an opening is made at the top, the pressure of the air from above forces it down. If, indeed, the hole in the cask is of large dimensions, it will run without any other hole, because air will get in at the upper side of the hole, while the liquor runs out by the lower part of it. For the same reason, a small hole is made in the lid of a tea-pot to insure its pouring out the tea, otherwise, when the tea-pot is quite full, it would be difficult to make the tea run out at the spout, the pressure of the air from below tending to prevent it.

On the same principle depends the performance of an instrument used by spirit dealers, for taking out a sample of their spirits. It consists of a long

Fig. 3. tin-plate tube, *A B*, fig. 3, open at the top at *A*, and ending in a small hole at *B*. The end *B* is dipped into the spirits, which rise into the tube; then the thumb is clapped on the mouth *A*, and the whole is lifted out of the cask. The spirit remains in it until the thumb be taken off; it is then allowed to run into a glass for examination. We are informed by certain travelers, that some of the rude tribes of Asia and Africa, with whom they have traveled, have a similar method of acquiring a draught of water, though they do not understand the principle on which it depends. They provide themselves, in their journeys, with a long hollow cane, and, when they wish to drink, or to give their companions a draught of water from a stream or pool, they place the hollow cane in the water, and apply their mouth to the upper end, and draw out the air, when the water rushes in and fills the interior of the cane; they then apply their thumb to the upper end, take the cane out of the water, and apply it to the lips of their thirsty companion, when the water rushes into his mouth. This mode of taking a draught of water may, in some cases, be very convenient when we cannot easily apply our lips to the surface of a running stream.

The action of the syphon depends on the same principle. A syphon is a bent tube, the one end of which is longer than the other, as *A B*, fig. 4. If the tube be filled with water, and the shorter leg be placed in a vessel of water, *E*, immediately upon withdrawing the finger from the longer leg, the water will flow out until the liquid in the vessel is emptied. By means of this instrument, we can convey water from a cistern over a rising ground, provided its perpendicular elevation above the level of the fountain does not exceed thirty-two feet, and that the leg, from which the water runs off, is *below* the level of the cistern; because

the weight of a column of water, about thirty-two or thirty-three feet high, is equal to the weight of a column of air reaching from the surface of the earth to the top of the atmosphere. The pressure of the atmosphere upon the water of the vessel, or cistern, produces this effect.

Fig. 4.

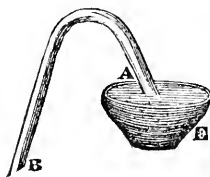

It might be shown, that the common pump for raising water, the fire-engine, the steam-engine, the forcing pump, and many other pneumatic and hydraulic engines, derive their power and utility chiefly from that extensive and universal agent—the pressure of the atmosphere; without the assistance of which many of our most powerful engines would be arrested in their operations, and sink into feebleness and insignificance. But this chapter shall be concluded by a few general remarks, suggested by this subject.

The discovery of the pressure of the atmosphere, and of its agency in the system of nature, formed a new era in the history of science. However common it is now to perform the Torricellian experiment, and to talk about the pressure of the atmosphere, it was a subject which, less than two centuries ago, struck with astonishment all the learned throughout Europe. So wonderful and incredible did it at first appear, that it was not until after the lapse of several years—until after opinions which had prevailed for ages had been overturned, and the most decisive experiments had been performed, in every possible way, that it was cordially received. And, indeed, when we consider the effects of this powerful agent, in the numerous operations both of nature and art, there is something which tends to excite our admiration more than all the fairy tales which the human fancy has created. We behold its operation in compressing the bodies of all animated beings—in counterpoising the internal pressure of the circulating fluids, and preventing the elastic force of the internal air from bursting the arteries and veins. We behold its operation in forcing-pumps and fire engines—in raising water from deep pits, and carrying it to the tops of the highest buildings—in giving motion to our spinning-machines, and in propelling large vessels along seas and rivers—in the action of Hero's fountain, of syphons, and barometers; and in many other cases where its agency could scarcely have been suspected. What can be more unlike than the working of a fire-engine, when spouting a column of water to the top of a building in flames, and the crawling of a fly upon a window-pane, or the ceiling of a room? Yet both these operations are performed by the same means, the pressure of the atmosphere.

But what appears no less striking than such operations, is, the pressure of the atmosphere upon our own bodies. It has already been stated, that this pressure amounts to above thirty thousand pounds. Were the half of this weight to fall on one side of our bodies, without being counteracted by any other power, it would produce an effect similar to that of a heavy wall, or the roof of a house falling flat upon us, and would

Infallibly drive the breath from our lungs, and crush to pieces every bone. What is it, then, which prevents such a terrible effect? A small quantity of air within us, which would not weigh above a single ounce, by its strong elastic force, counterpoises the effects of this tremendous pressure; so that, instead of lying as a mountain on our loins, it acts like wings to our feet, or like sinews to our limbs. When a flat bottle is empty, and laid on its side, we might imagine that the weight of the air would break it to pieces; but the air which is contained within the bottle, whether stopped or not, has the same power, by its elasticity, to prevent its breaking, as the air without has to crush it to atoms. But, if we apply a syringe to the neck of such a flat bottle, and exhaust the air which is enclosed within, the extraction of that small body of air, which, by its elastic spring, supported the sides of it, gives room to the external air to act on the surface of the bottle with all its force, and the bottle will fly into a thousand pieces. Such would be the case with respect to our own bodies, if an exact balance were not kept up between the pressure of the atmosphere without, and the elastic force of the air within; and, in this instance, as well as in a thousand other instances, we have a striking evidence of the wisdom and of the benevolence of Him who at first created and arranged all the powers and elements of nature, so as to render them subservient to the preservation and comfort of every species of animated existence.

It is owing to the same admirable arrangement of the Creator, that our dwellings are not crushed to atoms. Suppose an apartment only twelve feet square, and nine feet high, the pressure of the air upon the four sides, and the roof, containing five hundred and seventy-six square feet, is equal to one million, two hundred and forty-four thousand, one hundred and sixty pounds! This enormous pressure is balanced by the resistance of the small quantity of the air in the room, which weighs only ninety-seven pounds; so that here is a small weight of ninety-seven pounds counteracting

a pressure of 1,244,160 pounds! Without this wonderful balance no house could be habitable, no creature could remain alive; our glass-windows would be shattered to atoms; an army-tent, a peasant's house, or a shepherd's hut, yea, even our most stately edifices, would be crushed to atoms.

It appears, then, that we are immersed in an invisible fluid, which, on the one hand, by its enormous pressure, threatens to crush us to the earth, and, on the other, by its elastic force, to burst our blood-vessels, and tear our whole frame to pieces. The equality or equipoise of these two formidable and death-menacing powers, is our only safeguard and defense; and shows us how "fearfully and wonderfully" we are every moment preserved by that Almighty Being, "in whose hand our breath is, and whose are all our ways." Here we have a striking evidence of its benevolence and skill, in having, by his wisdom, reconciled and balanced two such formidable and contending powers, and so tempered them, that the impetuosity of the one is checked by the activity of the other; and all nature, instead of being shattered and destroyed, is preserved in safe and harmonious order. Were it his design to destroy the inhabitants of our world, or to render them miserable, we see how easily this could be effected. He has only to permit one of those powers now described to act without control, and the work of destruction is at once accomplished. So that in his "hand is the soul of every living thing, and the breath of all mankind." He upholdeth our souls in life, and his merciful visitation sustains our spirits. It is the province of true philosophy to trace the attributes of the Almighty, in every part of his operations, in the system of nature; and there is no scene throughout the universe, where his voice is not heard, and where his power and wisdom are not conspicuously displayed to those who have ears to hear, and eyes to see, and spiritual discernment to recognize the footsteps and the agency of an almighty, though invisible, Intelligence; "for in Him we live, and move, and have our being."

## CHAPTER IV.

### THE ELASTICITY OF THE AIR, AND THE PHENOMENA IT EXPLAINS.

THE atmosphere is that ocean of air which surrounds our globe on all sides, and in which we live and breathe. We are plunged into the bottom of the vast aerial sea, as the fishes are plunged into the depths of the ocean. Before we were brought into the world, we were furnished with a diaphragm and lungs, with cartilages, ribs, and muscles, to enable us to draw in this vital fluid. The first rush of the air into the lungs, and the cries which accompany it, announce life and sensation. More than a hundred muscles are employed in drawing in and expelling this aerial fluid; and this operation is continued, without intermission until death. In this element we pass the whole of our existence, from the cradle to the grave; it surrounds us wherever we go, whether on sea or land, and almost all our enjoyments depend on its benign agencies. This element, however, is impalpable to our senses. By its transparency, it escapes our ocular inspection; by

its thinness, it eludes our grasp; it cannot be perceived by our smell or taste, nor even by our organs of hearing, unless when it is in a state of tremor and agitation. But we are fully assured, in numerous instances, that the powers of nature may be in complete existence, though they are imperceptible to every organ of sensation; and hence we ought to guard against an error common both to the vulgar and to philosophers, that "the things which we cannot see have no real existence." The atmosphere, though invisible, is one of the most important and essential constituents of our terrestrial habitation. We could live for a few days without food, or drink, or sleep; we could pass weeks and months without the light of the sun, or the glimmering of a star; but if we are deprived only for a few minutes of the vital air, the lungs refuse to play, the heart ceases to beat, the blood stagnates in the arteries and veins; we faint, we sicken, we die. The powers



of the animal machine are broken; the thoughts and perceptions vanish; the dust returns to its kindred dust, and the spirit returns to God who gave it.

We shall now chiefly attend to the illustration of the elasticity of the atmosphere. By the elasticity of the air, is meant that property by which it contracts itself into less space, when an additional pressure is laid upon it, and by which it recovers its former dimensions when the pressure is removed. When I take a piece of whale-bone, or a watch-spring, and bring the two ends together, as soon as the force thus employed is removed, the spring returns to its former position. In such cases, we say that the body is elastic. When I take a small quantity of wool into my hand, and compress it, upon opening my hand, it recovers its former bulk, by the natural spring of its fibers; and hence we conclude that this substance possesses a certain degree of elasticity. In like manner, if I take a bladder and fill it with air and apply a force to the sides of it, so as to compress it into a smaller space, when the force is removed it immediately expands, and fills the same space as before, which clearly proves that the air contained in the bladder is of an elastic nature.

In consequence of this elastic property, the air always endeavors to expand itself, and to occupy more space. This is proved by taking a bladder, containing only a small quantity of air, tying its neck close, so as to prevent the escape of the air, and then placing it under the receiver of an air-pump. So long as the bladder is exposed to the pressure of the atmosphere, it will remain in the same state; but, when the air is exhausted from the receiver, and the external pressure removed, the side of the bladder, which was flabby and lax, stretches itself out, swells, and becomes tight, being raised by the elastic power. And, if the air be again let into the receiver, the bladder returns to its former shape. By a similar experiment it is shown, that the expansive power of the small quantity of air in the bladder is capable of raising leaden weights of a considerable size. In consequence of this strong elastic power of the air, a person, by blowing into a pipe connected with several bladders, has been able sensibly to raise a mill-stone, which was placed upon the bladders; which demonstrates the very strong expansive power of a very small quantity of air.

On the same principle, were a bladder, containing a very small quantity of air, taken to the higher regions of the atmosphere, it would gradually expand the higher it was carried, in consequence of the pressure of the atmosphere being gradually diminished, until, at length, it would burst the bladder, by the expansive force with which it is indued. In like manner, heat increases the elasticity of air. If a bladder, containing a small quantity of air, be placed, before a strong fire, the small portion of air it contains will expand until the bladder appears quite full, and ready to burst. There is another striking experiment which demonstrates this elastic force of the air. When a thin bottle with flat sides is firmly corked, so as to prevent the included air from escaping, is placed under the receiver of an air-pump, and the air exhausted, the spring of the air within it will dilate with so much violence as break the bottle to pieces. In like manner, were the pressure of the external air completely removed from our bodies, and the escape of the internal air prevented, the elastic force of the air within us would immediately tear the lungs and

other vessels to pieces, force the blood through the arteries and veins, and put an end to all the functions of the animal machine. If an animal, as a cat, mouse, or bird, be put under a receiver, and the air exhausted, the animal will be at first oppressed as with a great weight, then grow convulsed, their bodies will swell, and if they are allowed to remain only for a few minutes, they inevitably die. Were we to take a shriveled apple, and put it under the receiver of the air-pump, and exhaust the air, the skin will gradually swell as the pressure of the air diminishes, the wrinkles will be filled up, and the apple will appear as if fresh-gathered. When the air is let in, it returns again to its former withered state. The effect now stated, is owing to the elasticity of the air in the inside of the apple, which expands when the atmospheric pressure is removed.

From a variety of experiments it is demonstrated, that the spring of the air is equal to its weight, and produces the same effects as its pressure; for, action being equal to re-action, the force which the elasticity of the air exerts, in endeavoring to expand itself, is equal to the force with which it is compressed, just as it is in the spring of a watch, which exerts no force, but in proportion as it is wound up. If a quantity of air therefore, is included in a vessel, and is of the same density with the surrounding air, its pressure against the sides of the vessel is equal to that produced by the external atmosphere. Hence it is that we can break a square glass bottle, either by the direct pressure of the atmosphere, after the air has been extracted from it, or by removing the pressure of the atmosphere, and allowing the elasticity of the air within to exert its expansive force.

It is owing to the elasticity of the air that it is susceptible of dilatation and compression. To what degree air of the same density which it possesses at the surface of the earth is capable of being compressed, has not yet been fully ascertained. Dr. Halley informs us, that he has seen it compressed, so as to be sixty times denser than in its natural state. Some have supposed that no bounds can be fixed to the condensation of air. But it appears from some experiments made in London, and by the Academy of Florence, that no force whatever is able to reduce air into eight hundred times less space than that which it naturally possesses at the surface of the earth. It is owing to the power of being artificially condensed, that forcing-pumps produce their effects, and that an air-gun is enabled to discharge a ball to a considerable distance with great violence. The air is forced into a certain compartment of the gun by means of a syringe or condenser, which drives the air in, and suffers none of it to come back until it be sufficiently condensed. When the valve which confines the air is opened, the air by its elastic power rushes in behind the ball, and forces it out of the barrel with great violence. It would be better for mankind, however, that no such instruments were ever constructed. Science ought always to have for its object the construction of instruments and machines which have a tendency to promote the comforts of mankind, not those which may be employed by unprincipled men as weapons of destruction; and, therefore, the construction of this instrument is alluded to merely as an illustration of the powerful effect of the elasticity of the air. Would to God that guns, and cannons, and warlike instruments of all descriptions were forever unknown among men; that swords were beaten into plowshares, and spears into pruning-

books; that nation might no longer lift up sword against nation, but delight themselves in peace!

The dilatation or expansion of air, in virtue of its elastic force, is found to be very surprising. In several experiments made by the honorable Mr. Boyle, it dilated at first into nine times its former space, then into thirty-one times, then into sixty, and then into one hundred and fifty. Afterward, it was brought to dilate 8,000 times its space, then into 10,000 times; and, at last, into 13,679 times the space it originally occupied, and all this was effected by its own expansive force, without the help of fire, or the principle of heat. Hence it appears that the air we breathe near the surface of the earth is compressed by its own weight into at least the 13,000th part of the space it would occupy *in vacuo*. And, as it has been found that it may be compressed into a space sixty times less than that which it generally occupies, it follows, that the space which it will possess, when most dilated to that which it occupies when condensed, will be nearly as 820,000 to one! The amazing force of this elastic power of the air, were it properly directed, might be made to act as a strong mechanical power, and there can be little doubt that many of the terrific operations of nature—such as earthquakes, volcanoes, the rising of new islands from the bottom of the ocean, and the detachment of rocks and fragments of mountains amidst the ranges of the Alps, the Andes, and other mountainous regions—are to be ascribed, at least to the partial operation of this power, in combination with other physical agents.

It has been a subject of inquiry among philosophers, whether the elastic power of the air is capable of being diminished or destroyed. Mr. Boyle endeavored to discover how long air would retain its spring, after having assumed the greatest degree of expansion his air-pump could give it, but he never observed any sensible diminution. M. Desaguliers says, that air, which had been inclosed half-a-year in a wind-gun, had lost none of its expansive power; and Mr. Roberval asserts that he has preserved air in the same manner for sixteen years; and after that period, he observed that its projectile force was the same as if it had been newly condensed.

Various causes have been assigned by philosophers to account for the elasticity of the atmosphere. The general opinion which now prevails is, that it depends upon the latent caloric, or principle of heat, which it contains, and which enables it to retain its fluid form; and that caloric

is the most elastic body in nature. But this is only an explanation of elasticity by an assumption of elasticity. It removes the difficulty only one step farther on, and leaves us still in the dark as to the nature of elasticity, and the reason why caloric is endowed with an elastic power. In this, as well as in many other instances, we must rest contented in resolving it into the will of the Deity, that such a property should be possessed by atmospheric air in order to accomplish some wise and beneficent purposes in the economy of creation.

The elasticity of the air explains a variety of appearances in nature and art. For example, beer or ale, when bottled, contains in it a quantity of air, the elasticity of which is resisted by the pressure of the condensed air between the cork and the surface of the liquid. On removing the cork, the liquid and the air which it contains are relieved from this intense pressure. The liquid itself, not being elastic, is not affected by this; but the elastic force of the condensed air, which has been fixed in it, having no adequate resistance, immediately escapes, and rises in bubbles to the surface, and produces the frothy appearance consequent upon opening the bottle. On a similar principle we may account for the following appearance. If a man fall into the water, and is drowned, the carcass in a few days rises and floats on the surface. The privation of life, and the stagnation of the fluids, are soon followed by a putrid fermentation, which decomposes the body. This fermentation disengages a great quantity of air, which is disseminated among the internal vessels, and as this air cannot escape, the body swells by its expansion, until it becomes specifically lighter than the water, and rises to its surface. But, as the putrefaction goes on, the parts give way, the air escapes, and the body, being thus rendered specifically heavier than the water, sinks to rise no more. It is likewise by the elastic property of air that fishes are enabled to rise and sink in the water. They are furnished with an air-bladder, which they have the power of contracting or dilating at pleasure. When the fish compresses this bladder, its whole volume becomes less, and it sinks in the water; when the pressure is removed, the air in the bladder instantly expands, and it is enabled to rise to the surface. A variety of instances of a similar kind, illustrative of the elasticity of the air, might be exhibited: but instead of dwelling on these, we shall now proceed to another department of our subject.

## CHAPTER V.

### THE HEIGHT OF THE ATMOSPHERE; OR, THE ELEVATION TO WHICH IT EXTENDS BEYOND THE SURFACE OF THE EARTH.

THE height of the atmosphere is considered, by many writers and lecturers on this subject, as a point fully determined, and is treated as familiarly as the height of the Andes, or the Alps, or of Mount Etna, or Mount Blanc. But the height of the atmosphere has never yet been fully ascertained, and it is probable will never be accurately determined. If, indeed, the air were of an equal density, from the surface of the earth to the top of the atmosphere, its height might be easily determined; for it is found by experiment, that the weight of a column of air extending to the top of the atmosphere is equal to the weight of a column of water of the same base and 32 feet high. Supposing water to be 840 times heavier than air—multiply 840 by 32 feet, and the product will be 26,880 feet, or 5 miles and 160 yards for the height of the atmosphere, were its density at every elevation exactly the same as at the surface of the earth. But we know that the density of the air decreases and is more rarefied and expanded the higher we go; and, from other considerations we know that it extends far beyond the limit now stated; so that this calculation can afford us no accurate idea of the height to which the atmosphere extends.

Another method, therefore, of determining this point was devised by philosophers, which approaches nearer to the truth. It is found by observation, that the sun is about eighteen degrees below the horizon before twilight comes to an end in the evening. Now, twilight is caused by the rays of the sun being refracted and reflected from the higher parts of the atmosphere to the earth; otherwise, we should be involved in total darkness at the moment the sun descended below the horizon. From this circumstance, the height of the highest part of the atmosphere which is capable of refracting the rays of light may be determined.

Let  $F A B$  (fig. 5) represent the horizon of an

Fig. 5.

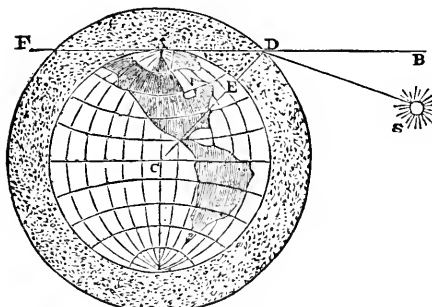

observer at  $A$ ;  $S D$ , a ray of light falling upon the atmosphere at  $D$ , and making an angle,  $S D A$ , of  $18^\circ$  with the horizon; the angle  $S D A$  will then be  $162^\circ$ . From the center  $C$ , draw  $C D$ , and it will be perpendicular to the reflecting particles at  $D$ , and will likewise bisect the angle  $S D A$ . In the

right-angled triangle  $C D A$ , the angle  $C D A$  is equal to  $81^\circ$ ; or, if we allow for refraction,  $81^\circ 30'$ ,  $A C$ , the radius, or half-diameter of the earth, is nearly equal to 4000 miles. Then by the rules of trigonometry,

As the sine of the angle $C D A$ . . .	81° 30'	. 9.995203
Is to the side $A C$ . . .	4000	. 3.602060
$S D$ is radius, sine of $90^\circ$ . . .		. 10.000000
To the side $C D$ , 4044½ miles . . .		. 3.606857

From  $C D$ , equal to the semidiameter of the earth and atmosphere, subtract  $C A$ , or the semidiameter of the earth, and the remainder,  $E D$ , equal to  $44\frac{1}{2}$  miles, will be the height of the atmosphere. In this operation, the logarithms of the second and third terms of the proportion are added, and the logarithm of the first term subtracted from the sum.

Thus 3.602060
10.000000
13.602060
9.995203
3.606857

The same result is produced by the following proportion:—

As Radius . . .	. . .	. 10.000000
Is to $A C$ 4000 . . .	. . .	. 3.602060
$S D$ is the secant of $A C D = 81\frac{1}{2}^\circ$ . . .	. . .	. 10.001900
To $C D = 4044\frac{1}{2}$ . . .		. 3.606860

It appears, then, that in ordinary cases, the air, at the height of forty-four miles and a half, is capable of reflecting to us the rays of light. But, as a sensible illumination has been perceived when the sun is much farther below the horizon than what has been now stated, there is some reason to conclude, that the air is sufficiently dense for reflecting a sensible degree of light at the height of nearly two hundred miles.

Various considerations, founded on meteoric phenomena, serve to prove that the atmosphere extends to a much higher elevation than forty-four or fifty miles. In the year 1719, a remarkable luminous meteor, or fire-ball, was seen, whose altitude was computed to be seventy-three miles above the surface of the earth. On the 18th of August, 1783, a brilliant fire-ball passed over Britain and the adjacent countries; and, from various circumstances which were particularly marked by different observers, it was calculated that its elevation above the earth could not be less than ninety or a hundred miles. In passing over certain parts of England a loud report was heard and a hissing noise. The meteor of 1719 is said to have been attended with an explosion, which was heard over the whole island of Great Britain, occasioning a violent concussion of the atmosphere, and seeming to shake even the earth itself. Now, in these, and multitudes of similar phenomena, we have instances of fire and flame being supported, and sounds conveyed to the earth from

a height of ninety or a hundred miles; and, consequently, even in these elevated regions, notwithstanding the great rarefaction of the air, it must still have the power of supporting flame and propagating sound. Even although the fire-balls alluded to be supposed to consist of electrical matter—which is the general opinion—yet the difficulty is not thereby removed; for, it is found, by some late experiments, that the electrical fire cannot penetrate a perfect vacuum. And, therefore, there is reason to conclude, that we are still ignorant of the precise extent of the atmosphere, and of the nature of the fluids which occupy its superior regions. That the meteors now referred to, however elevated, were not beyond the limits of the atmosphere, appears from this consideration, that the atmosphere revolves with the earth in its course round the sun, at the rate of 68,000 miles an hour. Now, as the meteor of 1783 moved from north to south, if it had been beyond the limits of the atmosphere, it would have been left, in the course of a minute, more than a thousand miles to the westward, by the earth flying out before it, both in its annual and diurnal course.

In short, it appears not altogether improbable to suppose, that the visible universe is filled with

some fine elastic fluid or air, but of such rarity as to be no sensible hindrance to the celestial orbs in their rapid motions through the regions of space; and that this fluid accumulates itself around every planetary body, in proportion to the quantity of matter it contains—the larger bodies attracting more of it and the smaller bodies less; and thus forming an atmosphere around each, corresponding to its nature and destination. And, if this be the case, the atmosphere of the earth can have no definite boundary, but may be said to mingle with the atmospheres of all the other planets which belong to our system. There is a certain portion of atmospheric air, however, which must always be considered as attached to the earth, and which revolves with it in its diurnal rotation, and is carried along with it in its course round the sun. If the atmosphere did not revolve along with the earth, we should constantly experience an easterly wind, blowing with an immense velocity of more than a thousand miles an hour, which would produce a most tremendous hurricane, which would level with the ground houses, trees, forests, and every prominent object on the surface of the earth. But the particular region where the motion of the atmosphere terminates, it is impossible for us to ascertain.

## CHAPTER VI.

### THE COMPOSITION OF THE ATMOSPHERE.

For a long series of ages, air was considered by philosophers as one of the four elements of which all things are composed, the other three being fire, earth, and water. But the discoveries of modern chemistry have fully demonstrated that all these are compound bodies—that even the air itself, fine and invisible as it is, is not a simple substance but compounded of different ingredients. This is one of the most curious and interesting discoveries of modern times; and little more than seventy years have elapsed since it was first surmised that the atmosphere is not a simple and homogeneous, but a compound fluid. The experiments which led to this discovery were first made by Dr. Priestley, on the 1st of August, 1774, on which day he obtained what was then termed dephlogisticated air, now known by the name of oxygen gas, and which forms one of the constituent principles of atmospheric air. It was also discovered in the year 1775, by M. Scheele, a Swedish chemist, without any previous knowledge of what Dr. Priestley had done, and he gave it the name of *emphyreal air*, from its powerful influence in supporting flame. But, instead of entering into the history of such discoveries, and of the processes by which they were made, a few of the properties possessed by the different ingredients of which our atmosphere is composed may be simply stated.

The air of the atmosphere, then, is found to consist chiefly of two very opposite principles or fluids, termed oxygen gas, and nitrogen gas, along with a very small proportion of fixed air or carbonic acid gas. If any portion of the atmosphere, such as the air in our apartments, be supposed to be divided into a hundred equal parts, twenty-one of these parts will be oxygen gas, about seventy-eight nitrogen, and a hundredth part, or

according to some chemists, a thousandth part will be fixed air, or carbonic acid gas. In the first place, a few remarks shall be offered on the nature and properties of oxygen gas.

This gas, like common air, is colorless, invisible, and elastic, and capable of indefinite compression and expansion. Its peculiar and distinguishing properties are:—1st. It is essential to combustion, and is the only principle with which we are acquainted by which flame can be supported. When acting by itself, it produces the most rapid conflagration of all combustible substances. If a lighted taper be let down in a jar of oxygen gas, it burns with such splendor that the eye can scarcely bear the glare of light, and, at the same time, produces a much greater heat than when burning in common air. If a piece of iron wire, a watch-spring, or a steel file, armed with a piece of wood, or phosphorus in an inflammable state, be put into this gas, the steel will take fire, throwing out sparks, and producing the most brilliant appearance, almost dazzling the eye with their splendor. In the next place, it is essential to the support of animal life; for it has been proved by many experiments, that no animal can exist for a single moment in any kind of air which does not contain a certain portion of oxygen; so that man, and all the other ranks of animated beings, may be said to depend upon this substance, not only for their comforts, but for their very existence.

Again, the basis of oxygen gives the acid character to all mineral and vegetable salts, from which property its name is derived; for the term oxygen literally signifies, the generator of acids. In short, oxygen is the vehicle of heat to the animal system—it imparts the red color to the blood in its passage through the lungs—it constitutes

the basis both of the atmosphere which surrounds the earth, and of the water which forms its rivers, seas, and oceans; for water is found to be nothing else than a combination of two kinds of air, oxygen and hydrogen gas. It pervades the substance of all the vegetable tribes, and enables them to perform their functions. In combination with the different metals, it serves the most important purposes in the useful arts; and, on the whole, may be considered as the most extensively useful, and the most powerful and energetic agent in the system of nature.

Oxygen gas may be procured from a variety of substances, particularly from niter, manganese, and the red oxide of mercury, and also from vegetables immersed in water and exposed to the solar rays. It is heavier than common air, nearly in the proportion of eleven to ten; one hundred and sixteen cubic inches of oxygen are found to weigh about thirty-nine grains, while the same quantity of common air weighs only thirty-five and a half grains.

One of the most extraordinary effects of oxygen appears when it is combined with nitrogen in a certain proportion, so as to form what is commonly called nitrous oxide. This gas consists of sixty-three parts nitrogen and thirty-seven parts oxygen. When it is put into a bladder, and inhaled into the lungs, by means of a pipe, and shutting the nostrils, it produces an extraordinary elevation of the animal spirits—involuntary muscular motion—a propensity to leaping and dancing—involuntary bursts of laughter—a rapid flow of vivid and agreeable ideas, and a thousand delightful emotions, without being succeeded by any subsequent feelings of languor or debility. When Mr. Southey, the poet, inhaled this gas, he declared that it produced in him sensations perfectly new and delightful. His first sensations were a kind of dizziness, so as to produce a fear of falling. This was succeeded by a laugh, which was involuntary but highly pleasurable, accompanied with a peculiar thrilling in the extremities perfectly new, and with the most delightful sensations. For many hours after this experiment, he imagined that his taste and smell were more acute, and is certain that he felt unusually strong and cheerful.

In Professor Silliman's *American Journal of Science*, we have the following account of the effects of this air on one of the professor's students, at Yale College, New Haven. "The person on whom the experiment was made, was a man of mature age and of a grave character. For nearly two years previous to his taking the gas, his health was so very delicate, and his mind so gloomy and distressed, that he was obliged almost entirely to discontinue his studies. In this state of debility, he inhaled about three quarts of the nitrous oxide. The consequences were, an astonishing invigoration of the whole system, and the most exquisite perception of delight. These were manifested by an uncommon disposition for mirth and pleasantry, and by extraordinary muscular power. The effects of the gas were felt without diminution for at least thirty hours; and in a greater or less degree for more than a week. But the most remarkable effect was upon the organs of taste. Before taking the gas, he felt no peculiar choice in the articles of food; but, immediately after that event, he manifested a taste for such things only as were sweet, and for several days, ate nothing but sweet cake. His singular taste was, indeed, carried to such excess, that he used sugar and molasses, not only upon his bread and butter and lighter food, but even upon his fresh meat and vegetables; and this he continues to do (says the

narrator) at the present time, although eight days have elapsed since he inhaled the gas. His health and spirits since that time have been uniformly good, and he attributes the restoration of strength and mental energy to the influence of the nitrous oxide. He is quite regular in his mind, and now experiences no uncommon exhilaration, but is habitually cheerful, whereas, before, he was habitually grave, and even, to a degree, gloomy and melancholy."

The writer has inhaled this gas, and can attest its pleasing and exhilarating effects. It produced a disposition to laughter, which no consideration could resist, and a wish to flee from the apartment in which the experiment was performed, that laughter might be indulged without restraint. It produced, likewise, an agility and a tendency to skip and jump; and, during its effect, a flow of pleasing ideas passed through the mind, and the lapse of a few seconds seemed to be magnified into as many hours. He has witnessed its effects both on the male and on the female sex. He has seen a little grave man, possessed of a meek and well-cultivated mind, capering through the room with all the airs of a king, brandishing his staff, and jumping until his head nearly touched the ceiling of the room, about eight feet high. When, afterward, asked why he brandished his stick, as if he had been going to fight, he replied, that he imagined there was a beautiful and extensive scene before him, which he wished to approach; but was prevented by the company around him, and, therefore, was obliged to clear his way, like a policeman when keeping off a crowd. The writer has, also, seen a female rapt into perfect ecstasy in consequence of the feelings she experienced, expressing her emotions in the most poetic exclamations, and tossing her shawl, her head-dress, and her slippers, from her as unworthy of attention, and altogether regardless of the looks and opinions of surrounding spectators. But, in order that this gas may produce its full effect, it requires some attention and dexterity in breathing it. The nostrils must be stopped, and no atmospheric air, if possible should be allowed to mix with the nitrous oxide. For want of attending to such precautions, some persons who attempt to breathe it never felt its peculiar effects.

It has been ascertained from various experiments, particularly from those made by the late Sir Humphrey Davy, that the nitrous oxide produces a somewhat similar effect upon insects, and other animals, which are found to jump and caper about in a frolicsome manner, as if highly delighted, when immersed in this gas.

These, and other effects, arising from the breathing of this very singular fluid, show us with what ease the Almighty could produce in us either the most delightful or the most painful sensations, merely by a slight modification or change of the principles of which the atmosphere is composed. Certain combinations of oxygen and nitrogen gas would produce a fluid, which would inflict the most excruciating pain, and destroy the corporeal system in a few minutes. Sulphuric acid, or aquafortis, a most deadly fluid, when taken into the mouth or stomach, is composed of seventy-five parts oxygen and twenty-five parts nitrogen, which is only a different proportion of the same ingredients which constitute the air we breathe. Were, therefore, our atmosphere composed of such a proportion of these two gases, it is easy to foresee the fatal consequences which would result from breathing such a fluid. On the other hand, we may learn how an intelligent mind connected with a corporeal frame, somewhat analogous to

ours, may be preserved in a state of uniform cheerfulness, and even of exquisite delight, by breathing an atmosphere somewhat similar to that of nitrous oxide. In other worlds, where the inhabitants have retained their original integrity, this may be the case. The other planets of our system or of other systems, although encompassed with atmospheres, may have them of very different qualities from ours, as to their transparency, their refractive and reflective powers, and the influence they produce on the mental and corporeal constitution of their inhabitants. Our atmosphere exhibits evident marks of Divine wisdom and benevolence; but it is adapted to man considered as in a state of depravity and imperfection, and appointed to a short mortal existence, and is not fitted to preserve him in an immortal existence in the present state, as was probably the case when this world was first arranged, and when man proceeded from the hands of his Creator as a holy being.

The next component part of the atmosphere is nitrogen gas, or what is sometimes termed azote. It is chiefly distinguished by its negative qualities. In the first place, no combustible body will burn in it; for, if a burning candle be immersed in a jar filled with nitrogen, it will be extinguished as instantaneously as if plunged in water. If a lighted taper be put into a close vessel full of common air, it will burn until all the oxygen be consumed, after which, as nothing but nitrogen remains, it will instantly go out. In the next place, it is incapable of supporting animal life; for, if any living being be obliged to respire it, it drops down dead almost instantaneously; and, from this circumstance it derived the name of azote, which signifies life-depriver. It is this gas which passes from the lungs at every expiration; and, were we to breathe it again, without any mixture of other air, we should be instantly suffocated. But, being lighter than atmospheric air, it rises above our heads, and enters into new combinations. It is owing to the presence of this gas, rising from several hundreds or thousands of lungs, that candles burn so dimly in the higher parts of crowded churches and assemblies. It is, therefore, a striking consideration, that nearly four-fifths of the air we breathe consists of this noxious and destructive fluid. But, though it is destructive to animal life, it forms an important element in the system of nature: it enters extensively into combination with other substances; and its existence in such a large quantity is a chief distinction between the constitution of animal and vegetable matter. It likewise exists in the products of several vegetables, and appears to be favorable to plants and flowers, which vegetate freely when surrounded with nitrogen. This gas is permanently elastic, transparent, colorless, and inodorous. Its specific gravity is 0.9748, that of common air being 1.0000; and one hundred cubic inches of it weigh about thirty grains. It slightly tinges delicate blue colors with green.

The other ingredient mentioned as forming a small portion of the atmosphere, is carbonic acid gas, or what was formerly called fixed air. This gas constitutes about a hundredth or, according to some chemists, about a thousandth part of the atmosphere. It is found in a state of combination with limestone, chalk, marble, manganese, and other substances, from which it may be extracted by the application of heat, or of the mineral acids, and in considerable abundance in mines, caves, the bottom of wells, in wine-cellars, brewers' vats, and in the neighborhood of lime-kilns. It is invisible and elastic, and is the heaviest of all

the gases, being considerably heavier than common air; and, therefore, may be poured from one vessel to another, like water. Its specific gravity is 1.5123, that of common air being reckoned 1.0000, so that its gravity is more than one and a half that of atmospheric air. One hundred cubic inches of oxygen weigh nearly thirty-four grains, while one hundred cubic inches of carbonic acid weigh more than forty-six and a half grains. It is this gas which has deprived of life many individuals who have descended into deep wells which had been long shut up from the air, and which produces so many ravages in coal-mines, under the name of the choke-damp; for it is almost instantaneously fatal to all animals that breathe it. Wherever it is found, it always occupies the lowest place, on account of its superior weight; and, therefore, in those caves where it abounds, a person may walk erect without danger; but, were he to lie down, he would be instantly suffocated. The Grotto del Cani, or the Dog's Grotto, in Italy, is well known. It is an artificial cave, in which there is a constant natural exhalation of carbonic-acid gas. The following feat is shown to strangers:—A man carries in a dog, and places him on the floor; the dog, if left long enough, dies; but the man is not affected; for the carbonic-acid gas, by its weight, occupies the lowest stratum of about eighteen inches depth, and the stratum above that height is pure air. But that it is poisonous to man, is evinced by the fate of persons who incautiously expose themselves to the vapors of charcoal burning in ill-ventilated apartments, or who venture into large vessels, in which fermentation had been conducted, as in breweries and distilleries. Many persons, from ignorance of the prevalence of this gas in the vicinity of lime-works, have lain down to repose, and in a short time have slept the sleep of death. As this gas is destructive to animal life, so it extinguishes flame. This can be strikingly shown by letting down a burning taper to the bottom of a glass jar, filling a bottle with carbonic-acid gas, and pouring it as if it were water into the jar; the flame is immediately extinguished. It is this gas which gives briskness and an agreeable pungency to fermented liquors, as porter and ale, and which appears on their surface in the form of a white froth. All kinds of spring and well-water contain carbonic acid, which they absorb from the atmosphere, and to which they are partly indebted for their agreeable flavor. Boiled water has an insipid taste from the absence of carbonic acid.

The base of carbonic acid gas is distinguished by the name carbon, which is nearly allied to charcoal. It exists largely in animal substances, and is extensively distributed in the mineral kingdom. The only body in which carbon has been found to exist in a state of absolute purity, is the diamond—a precious stone which has always been esteemed as the most valuable of the gems; a superiority which it owes to its hardness, luster, and high refractive power. It uniformly occurs crystallized, and presents a great variety of forms. Its specific gravity is 3.5, water being 1. Its hardness is extreme, so that it can be worn down only by rubbing one diamond against another, and is polished only by the finer diamond powder. The diamond, by being intensely heated with a burning-glass in oxygen gas, burns with a bright red light, and converts the oxygen into pure carbonic-acid gas, as charcoal does. Carbonic-acid gas is, therefore, to be considered as a solution of diamond in oxygen gas, even when it is prepared by the combustion of mere charcoal. It may not be altogether useless to remark, that in all places

such as wine-cellars, vaults, and deep wells, where the presence of carbonic-acid gas is suspected, it is proper to use the precaution of trying whether a candle or taper will burn in such places before we venture into them. If it be a deep well that requires to be cleaned, a burning candle should be let down with a cord, and if it go out before reaching the bottom of the well, no person ought to venture down before the noxious air is removed.

Such, then, are the three constituent principles of the atmosphere in which we live and breathe. We ought not, however, to conceive that the principles which form our atmosphere, and the proportion in which they are combined, constitute the only fluid which is fitted for supporting animal life and vigor. It is a fluid which seems to be adapted only to mortal men, and calculated to support the vital functions only to the period of eighty or one hundred years. It is not at all improbable, that it is owing to the large proportion of nitrogen which enters into the composition of the atmosphere that renders it unfit for supporting human life beyond a certain short and limited period; and that, were a much larger quantity of oxygen combined with other gases, in a certain proportion, and some slight changes effected in the other elements of nature, the lives of men and other animals might be protracted to several hundreds or thousands of years, and their spirits preserved, at the same time, in uninterrupted cheerfulness and vigor. Nor is it altogether improbable that, in the course of those improvements which are now commencing throughout the world, the air of our atmosphere may be greatly ameliorated, and rendered more salubrious and invigorating to animated beings, when the stagnant marshes which abound in every part of the globe shall be completely drained; when those immense forests which now cover a great part of Asia, of New Holland, and of the continent of America, shall be cut down, and the soil laid open to the influence of the solar rays—when the reefs which are now rising from the ocean, by the agency of minute creatures, shall be formed into continents and islands—when the barren deserts of Africa shall be transformed, by human science and industry, into fruitful fields—when the soil throughout every region of the globe shall be universally cultivated—when those immense thickets and jungles where the lion and the tiger now roam undisturbed, shall be changed into corn-fields, gardens, and orchards, and become the seats of civilization and of peace—in short, when the whole earth shall form one wide scene of rural and architectural beauty—we have every reason to believe that then the different climates of the earth will be greatly meliorated; that the fury of those storms which now carry destruction in their train will be greatly abated—and that the very atmosphere round us will be so modified, purified, and improved, as to render it capable of prolonging the life of man for perhaps two or three hundred years. Such effects correspond to what is predicted respecting the state of the world during the millennium, when the instruments of warfare shall be beaten into plowshares and pruning-hooks; when peace shall reign triumphant over the world, and when every man shall sit under his vine and fig-tree without fear of annoyance. At which period it is predicted, that the life of man shall be extended beyond its present boundaries. For thus saith Jehovah, “As the days of a tree\* are the days of my people”—

\* Certain species of trees are said to continue in vigor during a period of five hundred years, as the oak and several other trees.

“they shall build houses and inhabit them; and they shall plant vineyards and eat the fruit of them; . . . and mine elect shall long enjoy the work of their hands.” “Then shall the earth yield her increase; and God, even our own God, shall bless us.”

All the operations and ameliorations now alluded to are perfectly practicable, were the moral state of man improved. Could we undermine the principle of avarice and selfishness in the human heart; could we promote a spirit of harmony and general benevolence among human beings; and were the whole body of mankind to exert their powers in unison, in the cause of universal improvement—this earth, which, in many places, appears like a world in ruins, might, ere long, be transformed into one wide terrestrial paradise. But principles and dispositions directly opposite to these have, for the most part, hitherto prevailed. The present state of the moral world, and the infernal passions which have raged among mankind for ages past, have rendered it expedient, in the moral government of the Almighty, that the life of man should not extend much beyond “three-score years and ten,” in order that wickedness may be kept within certain bounds. And, therefore, no extraordinary or extensive improvements in science and art, or in the general cultivation of the earth, can be expected until the moral powers of man be cultivated and improved along with the intellectual; until the religion of Jesus be universally recognized in all its bearings; until its holy principles and practical precepts pervade every heart; and until a spirit of love, kindly affection, and benevolence distinguish the general mass of society in every land.

But, to return from this digression, it may be further remarked, that it is highly probable that the component parts of the atmosphere, in the ages before the flood, were very different from what they now are, and that it was owing to the peculiar constitution of the air which then existed, that the lives of the antediluvians were prolonged to nearly a thousand years. At the period of that awful catastrophe, when the fountains of the great deep were broken up, and the windows of heaven were opened, and the solid strata of the earth disrupted, it is probable that the atmosphere, too, underwent an important change by the dissolution of some of its elementary parts, so that it had a tendency to cut short the lives of mankind in all succeeding ages; and, until the ruins which were produced by that physical convulsion be in some measure repaired, the same cause will produce the same effects.

In short, an atmosphere is not peculiar to the globe on which we dwell. We know, from observation, that the planets Mars, Venus, and Jupiter, are furnished with atmospheres; and it is probable that every planetary world has a similar appendage. But their nature may be as different from ours as are the nature of their inhabitants and the constitution of the globes on which they reside. While our atmosphere is fitted only to prolong the lives of mortal men for a limited number of years, the atmospheres of some of the other planets may be so impregnated with the vital principle as to support immortal bodies in undecaying vigor, and to cause such an elevation of spirits as will produce uninterrupted ecstasy and delight. And all this may be effected by the same elementary principles of which our atmosphere is composed, but differently modified and compounded by the hand of the Almighty. The experiments with nitrous oxyde, formerly mentioned, show us what striking effects may be

produced by different combinations of the gaseous fluids; and, therefore, it is not improbable that the atmospheres of all the worlds in the universe are only different modifications of these substances, suited to the constitutions of their inhabitants, and the spheres they occupy in creation. In the operations of the Almighty throughout the system of nature, we perceive a striking simplicity in the means, producing an infinite variety of astonishing results. From a few simple substances—caloric, light, water, air, and carbon—are produced all the diversity of forms and colors which appear among the sixty thousand species of plants which adorn

the vegetable kingdom, and almost all the diversified phenomena of sublunary nature. And it is not unlikely that different combinations of these, and a few other substances, produce all that variety which appears throughout the boundless universe; and may give birth to all the changes and revolutions through which the different systems of creation may pass during every period of infinite duration. For He who arranged the system of universal nature “is wonderful in counsel, and excellent in working”—“his wisdom is unsearchable,” his power irresistible, and the ways of his providence “past finding out.”

## CHAPTER VII.

### THE BENEFICIAL EFFECTS OF THE ATMOSPHERE IN THE SYSTEM OF NATURE.

THIS subject presents an immense field of contemplation, which it would require several volumes fully to illustrate: and, therefore, a few general statements and illustrations can only be given.

1. In the first place, air is essentially requisite to the germination and growth of plants; and, therefore, to the influence of atmospheric air all the beauties of the vegetable creation are to be chiefly ascribed. By experiment, it is found that the access of atmospheric air is no less necessary for plants than it is for the continuation of animal life. Like animals, they are found to die when confined within a vacuum, or deprived of the vital air. The influence of the atmosphere is equally essential at every period of their existence, from the germination of their seeds to the full development of all their organs in the perfect plant. Their leaves, acting in some measure like the lungs of animals, absorb oxygen gas during the night, and carbonic-acid gas during the day; and this alternate process is found to be essential to their growth and nourishment. Even the green color of plants, which is produced chiefly by the influence of light, is proved not to be perfected without the co-operation of oxygen gas. It is found that pure air, or oxygen gas, may be procured by putting the leaves of plants into water, and exposing them to the sun. In purifying contaminated air, Dr. Priestly discovered that vegetables answered this purpose most effectually. Having rendered a quantity of air very noxious, by mice breathing and dying in it, he divided it into two receivers, inverted in water, introducing a sprig of mint into one of them, and keeping the other receiver, with the contaminated air in it, alone. He found, in about eight or nine days after, that the air of the receiver into which he had introduced the sprig of mint had become respirable; for a mouse lived very well in this, but died immediately upon being introduced into the other receiver, containing the contaminated air alone. It is likewise proved by experiment, that the simple component principles which are essential to the formation of vegetable matter are but three in number, namely, carbon, oxygen, and hydrogen; and these form the bases of carbonic-acid gas, oxygen gas, and hydrogen gas. From the various proportions in which these ingredients are combined, results almost all the variety of vegetable matters which fall under our notice.

To the atmospheric influence, therefore, we are indebted for all the productions of our fields and

gardens, and for all that diversity of prospect and coloring which the vegetable tribes spread over the landscape of the world. It is true, indeed, that water is also necessary for the production of plants. But what is water? It is nothing else than a composition of two kinds of air, oxygen and hydrogen, combined in certain proportions. Now, it is found that plants have the power of decomposing water into these two principles, throwing off a part of the one, and absorbing a part of the other. The elasticity of the air has likewise an important influence on the air-vessels of vegetables; for the contained air, alternately expanding and contracting, according to the increase or diminution of the heat, alternately presses the vessels, and eases them again, thus keeping up a perpetual motion of their juices. It has likewise been ascertained, from recent experiments, that the pressure of the atmosphere has a powerful influence on vegetation, which suggests to us one of those causes which prevent trees from flourishing on the elevated sides of lofty mountains.

2. The pressure of the atmosphere has an influence in preserving water in the state in which we find it. Nothing is of more importance to the comfort of man and other creatures, and to almost all the processes of the arts, than water—without which our globe would be transformed into an immense desert. But, if there were no atmosphere, all the waters on the face of the earth would boil, and be evaporated with a very slight degree of heat. The ocean would be drained to its lowest caverns, the rivers would cease to flow, the springs would be dried up, and the whole surface of the land exhausted of that moisture so essential to the existence of the animal and vegetable world. Indeed, it is not improbable, that all the substances on the earth, solid as well as fluid, would be dissipated into vapor. That such effects would actually take place, appears from a variety of experiments. If we fill a long-necked bottle with boiling water, and cork it close, so as to exclude the air, and place it in a basin of cold water, the water will sink in the neck of the bottle as it cools. This shrinking of the water will produce a vacuum in the upper part of the bottle, and the water within it will be seen to recommence boiling with great violence, which can arise from nothing but the cork taking off the pressure of the atmosphere from the water. In like manner, if we place water that has been cooled several de-



grees below boiling, under the receiver of an air-pump, it will begin to boil as soon as the air is exhausted. It requires a heat of  $212^{\circ}$  of Fahrenheit's thermometer to make water boil under the common pressure of the atmosphere; but in the exhausted receiver of an air-pump, it boils when heated to only about  $67^{\circ}$ . The phenomenon exhibited by what is called the pulse-glass, is also owing to the same cause. This glass, having two bulbs, is partly filled with spirits of wine, the air is extracted, and the glass hermetically sealed; and when the hand is applied to one of the bulbs, it causes a heat which produces an ebullition in the spirits of wine. It is likewise owing to this pressure that porter, ale, and other fermented liquors are preserved in bottles; without which they would either rush with violence out of their mouths, or burst them to pieces. It is owing to the same power that boiling water is preserved in our pots and kettles, when used in cooking, without the influence of which it would soon dilate itself, rush over the vessels, and be dissipated into vapor.

3. It is to the atmosphere we are indebted for the action of fire and flame. Fire is essentially necessary to human existence, even in the warmest climates of the globe. By its means the inhabitant of the desert frightens from his dwelling the beasts of prey, and drives away the insects which thirst for his blood. By its means also, man, in every country, prepares his food, dissolves the metals, vitrifies rocks, hardens clay, softens iron, tempers steel, and gives to all the productions of the earth the form and combinations which his comfort and necessities require. But, without the vital air, no flame can be extricated, nor fire made to burn. This is proved by putting a burning taper within the receiver of an air-pump, and when the air is extracted it is instantly extinguished. The act of combustion effects an analysis of the air; it separates its component parts: the oxygen of the atmosphere combines with the combustible body; caloric, in the form of sensible heat, is thrown off in every direction; and therefore, where no oxygen exists, it is impossible to make even the most combustible body produce heat or flame.

4. It is on the influence of the atmosphere that respiration of all animals depends. The process of respiration is carried on by means of the lungs. These are distinguished into right and left. The right, or larger lung, is divided into three lobes; the left or smaller, into two. The internal fabric of the lungs is composed of an infinite number of small membranous cells, full of air, communicating with one another, the number of which Dr. Keil and other anatomists have computed to be at least 1,744,000,000, that is, one thousand seven hundred and forty-four millions. The air from without rushes into these vesicles, and is again expelled 1200 times every hour: and during the same time we consume about 48,000 cubic inches of air, or, at the rate of seventy-seven wine hogsheads in a day. The chief uses of respiration are—1, to bring the blood in contact with the air; 2, to effect certain changes in the mass of the blood; and 3, to produce animal heat. Accordingly, the lungs are so constructed as to allow the largest possible quantity of deteriorated blood to enjoy the fullest intercourse with the largest possible quantity of vital air. It has been calculated by Dr. Hales, that each air-cell is the one-hundredth part of an inch in diameter, and that the amount of surface furnished by them, collectively, is equal to twenty thousand square inches. Others have estimated the surface to be more than 1500 square feet; and Dr. Mouro states, that

it is thirty times the surface of the human body. From numerous experiments, it has been found that the blood perpetually receives oxygen gas from the atmosphere by the agency of the lungs, and that its red color is derived from this source. The blood is purple when it arrives at the lungs from the heart; but, having there thrown off hydrogen and carbon, it imbibes the vital air of the atmosphere, which changes its dark color to a brilliant red, rendering it the spur to the action of the heart and arteries, and the source of motion and of animal heat. The blood is thus indebted every moment to the invigorating influence of the atmosphere, without which the heart would cease to beat, the circulating fluids would stagnate, and the body become a cold, putrid mass, without sensibility or motion.

The following are some of the results of experiments in relation to this subject, lately performed by Dr. S. Smith, "1. The volume of air ordinarily present in the lungs is twelve English pints. 2. The volume of air received by the lungs, at an ordinary inspiration, is one pint. 3. The volume of air expelled from the lungs, at an ordinary expiration, is a little less than one pint. 4. Of the volume of air received by the lungs at one inspiration, only one-fourth part is decomposed at one action of the heart, and this is so decomposed, in the five-sixth parts of one second of time. 5. The blood circulates through the system, and returns to the heart in one hundred and sixty seconds of time, which is exactly the time in which the whole volume of air in the lungs is decomposed. These circuits are performed every eight minutes; five hundred and forty circuits are performed every twenty-four hours. 6. The quantity of blood that flows to the lungs, to be acted upon by the air at one action of the heart, is two ounces, and this is acted upon in less than one second of time. 7. The quantity of blood in the whole body of the human adult is twenty-four pounds avoirdupois, or twenty pints. 8. In twenty-four hours, twenty-four hogsheads of blood are presented to the lungs, to receive the influence of the vital air. 9. In the mutual action which takes place between the quantities of air and blood which come in contact in twenty-four hours, the air loses three hundred and twenty-eight ounces of oxygen, and the blood, ten ounces of carbon."

Such are the wonderful processes in reference to respiration as dependent on the atmosphere. When we reflect that a stratum of blood, several hundred feet in surface, is exposed to a stratum of air still more extensive, and all compressed within the compass of a few inches, we cannot but be filled with admiration at the Divine wisdom displayed in this and many other functions of the human system, which so far surpass all the contrivances of genius, science, and art. In every part of the workmanship of the Almighty, even the most minute, we perceive the impress of infinite goodness and intelligence, demonstrating that He who formed the human frame and the surrounding elements is "wonderful in counsel, and excellent in working." Not only are terrestrial animals and the fowls of heaven dependent for existence on the atmosphere, but even the fishes of the sea cannot subsist for any length of time without its invigorating influence. Every fish is furnished with an air-bladder, by which it is enabled to rise in the water, or sink into it at pleasure. The lungs of fishes are their gills; these consist of filaments, arranged somewhat like the feathers of a quill; they are found to be covered with minute processes, crowded close

together, and on which are observed by the microscope, millions of capillary blood-vessels spread, like a net-work, over the whole surface. It is through the thin coats of these vessels that the air acts upon the blood they contain. When a fish is taken out of the water, the reason it cannot breathe is, that these filaments collapse, and adhere together in a mass, and the air cannot separate them. If the air be extracted from the water in which fishes swim, or if they have no free communication with the air, they are soon deprived of existence.

5. The atmosphere is the medium in which the process of evaporation is carried on, and in which clouds, rain, and dew are produced. By the heat of the sun and other causes, an immense portion of matter is daily carried up into the atmosphere in the form of vapor, in which state it occupies a space 1400 times greater than in its ordinary liquid state. It has been found, by experiment, that an acre of ground, in the course of twelve hours of a summer's day, dispersed into the air by evaporation, 16,000 gallons of water. Every hour there are exhaled in this way, from the surface of the ocean, many millions of gallons, and every year about 40,000 cubical miles of water. This vast body of water, sometimes in an invisible form, and sometimes in the shape of clouds, is carried by the winds over the different regions of sea and land. A part of this water is condensed into thick clouds, and falls down in rains on the continents and islands, to fertilize the soil; a part descends on the seas and oceans; and another part supplies the sources of the rivers, by which it is again returned to the ocean, whence it was chiefly derived. This continued circulation of vapor through the atmospherical regions, is one of the most important processes in the system of nature connected with our globe. By means of it, the Creator displays his wisdom and unbounded benevolence, in conveying fertility to the different climates of the earth, and thus supplying nourishment and comfort to man and to all the inferior orders of animated existence. But it is evident that, without the ministration of the atmosphere, these beneficent operations could not be carried on, and the earth would be left to parch under the rays of the sun, until it were transformed into a bleak and barren desert. It is owing to this process of evaporation that our clothes and linens are dried, after having been washed, and that our roads are rendered clean for walking upon, after having been drenched with heavy showers of rain, or covered with deep snows; without the operation of which, a thousand discomforts and inconveniences would be felt in all the scenes of domestic life, and the operations of art; and this world would cease to be an abode of happiness and enjoyment.

6. The density of the atmosphere gives buoyancy to the clouds, and enables the feathered songsters to transport themselves with ease from one part of the earth to another. If the air near the earth were much rarer than it is, the clouds would sink to the surface of the earth, involve the world in a dismal gloom, and intercept our views of the beauties of the terrestrial landscape, and of the glories of the midnight sky. The birds would be unable to perch on the tops of lofty trees, or to wing their flight from shore to shore. As a proof of this, Mr. Robertson, who ascended in a balloon from St. Petersburg, in 1894, informs us that he took along with him some live pigeons, and, at different heights, gave liberty to these birds, who seemed very unwilling to accept of it. The poor animals were so terrified with their situation, that

they clung to the boat of the balloon until they were forced from it, when it appeared their fears were not groundless; for their wings were nearly useless, from the rarity of the air, and they fell toward the earth with great rapidity. The second struggled with eagerness to regain the balloon, but in vain; and the third, thrown out at the greatest elevation, fell toward the earth like a stone, so that he supposed it did not reach the earth alive. This was evidently owing to the extreme rarity of the air in those upper regions to which the balloon ascended.

7. The atmosphere is the region in which winds are produced, which perform many important offices in the economy of our globe. Winds are nothing else than portions of air in motion; and although they sometimes excite our fears by the violence of their rage, and scatter destruction by sea and land; yet their agency, on the whole, is highly beneficial, and even essentially necessary to mankind. They purify the air by keeping it in perpetual motion; they disperse the noxious vapors that are continually rising from stagnant marshes and common sewers; they sweep the chambers of the atmosphere; they ventilate the streets of populous cities, and prevent the accumulation of those noxious effluvia which would produce pestilence and death; they scatter the seeds of various plants over every region; they fan the air under the scorching heats of summer, and diffuse refreshment over a fainting world; they make our millstones revolve as nimbly as the wheels of a chariot, and they serve as wings to our floating edifices, to impel them across the ocean, and to bring them back laden with the treasures of distant lands.

Were the agitation to cease which the wind produces, all nature would be thrown into the utmost confusion. Navigation to distant shores, as hitherto most generally conducted, would be at a stand, and ships would be arrested in the midst of the ocean. The vapors exhaled by the heat of the sun would remain forever fixed over those particular spots whence they arose, instead of being dispersed, as they now are, over every region. One part of the world, by the interposition of stationary clouds, would be forever deprived of the direct influence of the solar rays, and of the light of the stars; while, in another part, the soil would be parched, and the grass burned up, for want of a veil of clouds to modify the heat of the sun. One region would be scorched for want of moisture, and another drenched with excessive rains. The putrid exhalations of dunghills, marshes, and populous cities, would remain perpetually suspended around the places whence they arose, and produce diseases and pestilence, which would sweep the inhabitants of the earth in rapid succession to the grave. But in the existing economy of nature, all such disastrous effects are prevented by the agency of the winds, which distribute the clouds in due proportion over every land, and serve as ventilators to all the regions of the atmosphere.

8. Air is the vehicle of smells, by the transportation of which we become acquainted with the good or bad qualities of the food which is set before us, and are warned against sitting in places that are damp and dangerous, or entering houses that are unwholesome or infectious. By means of the air, the odoriferous effluvia of plants and flowers are diffused over the fields, and conveyed to the nostrils, to increase our delightful sensations, when wandering among the scenes of nature.

9. Air is likewise the medium of sounds. In consequence of its elasticity and undulating

motion, it conveys to us knowledge and enjoyment of different kinds, which cannot be conveyed to the organs of sight, of taste, or of smell. A few strokes on a large bell will, in the course of a few seconds, by the undulation of the atmosphere, reach the ears of a hundred thousand men, and convey intimations either of joy or terror. The sounds produced by the undulations of the air may be considered as so many couriers running backward and forward, and in every direction, to warn us of danger, or to inspire us with joy, and to communicate various delightful sensations. When we walk along the road, musing, and unapprehensive of danger, a mail-coach may be whirling on in its rapid career, and just at our heels, ready to roll over us; but the air, like a watchful friend, dispatches a courier from a considerable distance to warn us that danger is approaching, and to remove to the path of safety. While we walk along the streets of London, and other cities, we are continually in danger of eabs, coaches, drays, and other vehicles, rolling upon us; and were it not that the air, by its undulations, gives us timely notice of their approach, the accidents from this cause which occasionally occur, would be much more numerous than they now are. To this property of the air, we owe all the advantages we derive from hearing sermons and lectures, and all the pleasures we enjoy from friendly and instructive conversation. By means of the tongue and the lips we form articulate sounds, which, by the previous consent of mankind, become the signs of certain ideas; these sounds are conveyed to the ears of our friends, and inform them of the thoughts and ideas that were previously passing through our minds, and their understandings and hearts become impressed with the same sentiments. Without the ministration of the atmosphere in such cases, all would be sullen and unmeaning listlessness and silence, as in the intercourse of the deaf and dumb. So that the air may be considered as the cement of society—the medium of communication between one mind and another, and the interpreter of the thoughts and purposes of mankind.

To the same cause, we are indebted for all the pleasures and harmonies of music. Music is one of the purest and most refined of our sensitive pleasures. It possesses the power of charming our ears, soothing our passions, and affecting our hearts; it dissipates the gloom of melancholy, animates the vital spirits, and gives sublimity to our thoughts and sentiments. When a lady tunes her melodious voice, or touches with her fingers the keys of the piano-forte, or the strings of the lyre, the air distributes every musical variation and every note, with the utmost precision. It conveys its message with the greatest impartiality to the ear of every listener. Though many instruments may be employed, and a thousand persons be present, and placed in every direction, it distributes the harmony alike to every ear. It keeps the most exact time—it conveys the slightest inflections of the voice, and the smallest variation of a tone. It runs through the whole compass of music, swells the sounds, and makes them even thunder in our ears. The next moment, it makes them flutter and melt into dying strains. After this, it swells the notes again, and sinks them in their turns. Thus it expresses, in the most lovely manner, every passion and emotion of the soul, and charms every heart with its persuasive sounds.

That all the effects now stated are owing to the ministration of the atmosphere, is proved by one decisive experiment. Place a small bell under the

receiver of an air-pump; let it be rung, and the sound will be heard at a considerable distance. Exhaust the air from the receiver, and the sound can scarcely be heard by the nicest ear. Even in places where the air is not excluded, but only highly rarefied, as in the higher regions of the atmosphere, sounds are scarcely heard. Fredrichius, a gentleman of Hungary, informs us, that when he was on one of the loftiest tops of the Carpathian mountains, he fired a pistol, which at first made no greater noise than if he had only broken a stick or a staff; but after a little time there was a murmuring for awhile which filled the valleys and woods below. Descending to the lower valleys and the rugged rocks, he fired again, which made a dreadful sound, as if great guns had been discharged, and as if the whole mountain had begun to tumble about his ears. The sound lasted for half a quarter of an hour, until it had reached the most secret caverns, where the sound was enlarged and reflected back in every direction. These facts show that the elasticity of the air, which is always greatest where the air is densest, is essential to the propagation of sound.

10. The atmosphere is the cause of that splendor and universal light around us, which lays open to our view the landscape of the world. Were this atmosphere destroyed, we might see the sun without enjoying the light and brilliancy of day. That luminary would, indeed, strike our eyes with a vivid brightness when we turned round to behold his flaming orb; but it would appear only as a blazing fire during night in a spacious plain, where all is gloom and darkness around.—It would suddenly burst on our view in the eastern horizon, in the morning, and would not change its aspect in the least, during its course through the heavens, until it suddenly disappeared in the western sky. The objects immediately around us would be partially visible; but the rays of the sun which fell on distant objects would be forever lost in the expanse of the heavens; and when we turned our back to the sun, nothing would present itself, but an abyss of darkness, and the whole horizon involved in a dismal gloom. The number of objects in the heavens would, indeed, be augmented, for the stars would shine through a canopy as black as ebony, even when the sun was above the horizon; but all the gay coloring of the terrestrial landscape, which now delights the eye and the imagination, would be forever veiled from the inhabitants of the world. In such a state of things, it would be always night; and the difference between such a night and that which we now enjoy, would be, that the celestial orbs, instead of being grounded on a beautiful azure sky, would appear on a black canopy, like so many white points on a dismal mourning carpet.

But the Almighty, whose arrangements have all a respect to the happiness of his creatures, has enveloped our globe with an atmosphere, and has endowed it with a capacity of reflecting and refracting the rays of light in all directions. This atmosphere, too, is charged with innumerable myriads of watery particles, exhaled by evaporation from every region of the sea and land. In the serenest days of summer, when no clouds nor vapors are to be seen, these rarefied particles of water, which are imperceptible to the keenest eye, fill the whole sphere of the atmosphere around us, both above and below the region of the clouds. It is among these rarefied waters in the higher regions of the air that the rays of light reflected from the surface of the land meet, and are again reflected in every direction to the earth;

and hence is produced that beautiful azure color which distinguishes the aspect of the heavens. This azure is sometimes lighter, according to the quantity of the rays which enter the atmosphere, and sometimes darker, when the absence of the twilight heightens the blue of the celestial concave, by means of that black and void space which lies beyond the limits of the atmosphere. In corroboration of these remarks, it may be noticed, that the higher we ascend above the surface of the earth, the darker does the sky appear. And hence all travelers affirm, that, on the tops of lofty mountains, it sometimes appears as black as ebony, which causes the Milky Way to appear like a pure flame shot across the heavens, and the stars to shine with a greater brightness, and to appear far more numerous than in the plains below.

II. The atmosphere is the cause of the morning and evening twilight. We all know that the day is gradually ushered in after the darkness of the night. More than an hour before the rising of the sun, in this part of the world, a streak of light appears in the eastern horizon. This light increases in brilliancy every moment—the landscape of the earth, which had been previously covered with a mantle of blackness, appears gradually to emerge from an abyss of darkness, like the light at the first creation—the circle of the horizon becomes inflamed with a bright vermilion—the mountain tops are tinged with purple; and at length appears the most beautiful and sublime object in nature, the sun rising in his might and glory. And, when this luminary has described the circuit of the heavens, and passed the verge of the western horizon, darkness does not come on instantaneously, but by slow and imperceptible degrees, so as to warn us to prepare for its approach. The season of twilight, particularly that of a summer evening, is perhaps one of the most agreeable and interesting periods of the day. How many delightful walks and excursions—how many cheerful and solemn musings—how many endearing intercourses of love and friendship does it recall to our recollection, when we strolled along the solitary walks, or reclined in the bower of friendship, until the rising moon and the twinkling stars called us to our nightly repose!

Now, all such pleasures and advantages, derived from the twilight, are owing to the agency of the atmosphere. When the sun approaches in the morning within eighteen degrees of the horizon, his rays strike obliquely on the higher parts of the atmosphere, and, instead of passing directly forward, they are refracted, or bent a little downward, and thus descend by inflection to the earth. In this way we reap the benefit of those rays which would otherwise have been totally lost, and enjoy the light of day for a considerable time before the sun reaches the horizon. It is owing to the same cause that the sun is visible several minutes before he is actually above the horizon in the morning, and after his setting in the evening. This increases the length of every day, about  $6\frac{1}{2}$  minutes at an average, which amounts to  $3\frac{1}{2}$  equinoctial days in a year, and nearly a whole year's sunshine in the course of a century. And, if we reckon an hour and a half of twilight in the morning and as much in the evening, at an average, through the different seasons, we have more than ninety equinoctial days of twilight throughout the year. This is a circumstance of the utmost importance to those who inhabit the polar regions; in consequence of which, the inhabitants of Nova Zembla and of Greenland enjoy the direct light

of the sun for thirty-two days while he is under the horizon, beside the long twilight which precedes his rising, and continues after his descent below the horizon. But what would be the consequences if we had no twilight? Not only should we be deprived of the advantages now stated, but subjected to many inconveniences and dangers. Should the day break in upon us all at once in meridian brightness, immediately after the dark shades of night, our eyes would be dazzled, and in danger of being blinded by its excessive splendor. Should the night rush on in the same precipitate manner, and hurry us in a moment from the splendors of the day to the horrors of midnight, it would strike the living world with amazement. The traveler would be arrested in the midst of his journey, and bewildered with terror; and if the sky were then covered with clouds, the darkness would be so thick and black, that not the least glimmering ray would strike across the universal gloom nor a single object be perceived, even within the distance of a foot. Man would then appear as if he were placed without an object near him in the midst of infinite space—

—“Dark as was chaos, ere the infant sun  
Was rolled together, or had tried his beams  
Athwart the gloom profound.”

These arrangements, then, by which light is reflected over the face of nature, and twilight is produced, evidently show the wisdom and intelligence of the Almighty Creator, and his benevolent regards to his sensitive and intelligent offspring. A few small bubbles of air and water appear very insignificant to the eye of man. But in the hand of the Almighty they work wonders of love and beneficence. He has distributed them over our heads in every direction with so much caution and skill, in order that the light of his sun and his stars might not be rendered useless to the world. With these invisible particles of water and air, he enriches and embellishes whatever he pleases; and in his hands they become an inexhaustible source of glory and happiness. From these insignificant atoms, he fetches the brightness of the aurora, and draws forth those twilights which lengthen our days, and prepare our eyes for receiving the brightness of the meridian sun. From these he produces the splendor of day, which the sun itself could never procure us. He makes them contribute to the preservation of that heat which nourishes the vegetable kingdom, and which is essential to the comfort of “everything that lives.” Of them he has formed that magnificent arch which surrounds us on all sides, which enchants the eye of every beholder, and forms the canopy of our terrestrial habitation; for it is the light reflected from the air, and the innumerable particles of vapor it contains, which produces that beautiful azure which adorns the vault of heaven. This azure canopy the Creator might have painted with a darker hue, or even made it entirely black. But black is a sad and dismal color, which would have thrown a melancholy gloom over the face of nature. A deep red would have been almost as disagreeable and hurtful to the sight; a white color, by its excessive glare, would have been oppressive to every eye, and would have prevented the light of the planets and stars from being distinguished. A yellow would not have been quite so unsuitable; but this color was reserved for the aurora which adorns the sky before the rising of the sun. Beside, a whole arch of a yellow color would not have presented a sufficient contrast to the light of the

celestial luminaries. The green, which is a pleasing color to the eye, would have formed a better ground for the light of the stars; but it is with this lovely color that the Almighty has adorned the surface of our earthly abode, and has spread it as a carpet under our feet; and it was necessary that there should be a contrast between the color of the earth and of the sky, in order to complete the beauty and the magnificence of the scene of nature. The blue is, on the whole, a mild and pleasant color, without gloom or sadness in it; and while it forms a contrast to the verdure of the fields, it has the additional merit of forming a proper ground on which luminous bodies may be seen, and thus heightens the luster and beauty of the stars.

In such admirable arrangements we cannot fail to perceive the marks of intelligence and skill, in causing the assemblage of invisible atoms to produce so many sublime and beneficent effects; and we must be void of gratitude, if we do not recognize the hand of Divine goodness in adorning our habitation with so many beautiful contrasts, and rendering every scene of nature subservient to our convenience and delight.

12. The transparency of the atmosphere is not the least of its advantages. It is not, indeed, perfectly transparent, otherwise it would not reflect the blue color of the sky, nor would the distant mountains appear bedimmed and tinged with purple. But it has such a degree of transparency, that every object on the terrestrial landscape, within a reasonable distance, can be distinctly perceived. Even objects at the distance of a hundred and fifty miles, are visible through the air; and the telescope, though it magnifies the aerial particles, can make objects, at the distance of twenty miles, appear as if they were placed at the distance of three hundred yards. Were the air tinged with the least degree of yellow, red, or green, it would give the same color to every other object, just as a stained glass makes every object seen through it appear of the same color as itself. Were its particles much larger, and more opaque than they now are, so as to become perceptible to the eye, we should never obtain a distinct view of any other object. We should then see the air and the exhalations rising from the surface of the earth continually before us, like the particles of dust in a darkened chamber, when the rays of the sun are admitted through a small hole.

But the Almighty, by rendering the air invisible, has enabled us, in the first place, to take an extensive and delightful view of his wonderful operations in heaven and earth, and of all the objects which immediately surround us—and, in the next place, has concealed from our eyes those objects which would have excited disagreeable sensations and even disgust. If the air, like all other bodies, were an object of sight, the exhalations from the earth and waters would be much more easily discovered. The smoke of our chimneys still remaining visible as it ascended, would disfigure the rich landscape of the world and obscure the canopy of heaven. We should perceive all those gross humors which an incessant perspiration drives out of the bodies of all animals, and all the filthy exhalations that rise from kitchens, dung-hills, stagnant marshes, streets, and common sewers. We should be apt to imagine our situation both unsafe and contagious, unless we fled into deserts and mountains, to avoid those incessant annoyances which would be the unavoidable result of such a visibility of the air and its exhalations. At the same time, lest these vapors should

prove injurious to us through their invisibility, the good providence of God has forewarned us of such danger, by imparting to us the sense of smell, and has also appointed the winds to disperse such nuisances, to carry them aloft, and to serve as the ventilator of the atmosphere; for by the sense of smell, we are enabled to perceive when we are within the range of pestilential effluvia; and the winds seldom permit the air to remain in a stagnant state, provided our habitations are so arranged as to be within the sphere of their influence.

If we wish to feel grateful to the Supreme Disposer of the universe for the blessings of that world in which he has placed us, it is requisite that we should frequently fix our attention on such circumstances as those now stated. We pass from one day to another, and frequently from one period of human life to another, without reflecting on those admirable contrivances which appear in every surrounding object, by which our comforts are secured, and the universe rendered a spectacle of beauty and grandeur. Because we have never yet contemplated a world in confusion and ruins, we are apt to imagine that the arrangements around us could not be otherwise than they presently are. But, were that Being who created the atmosphere to make only a very slight alteration in its constitution—were he just to alter two apparently insignificant circumstances—were he to deprive it of its refractive and reflective powers—and were he to render it visible by tinging it with any color, all other things remaining as they now are—immediately the scene of nature would be divested of all its beauty and magnificence—and this earth which now cheers so many millions of animated beings with its comforts and embellishments, would be transformed into a scene of misery, an abode of darkness and desolation.

13. Were the atmosphere capable of being frozen, or congealed into a solid body, the most disastrous consequences would immediately ensue. All other fluids with which we are acquainted are subject to congelation. Even spirits of wine, which long resist the influence of the cold, and are, therefore, used in our thermometers, have been converted into a solid mass, by the cold of northern regions; and quicksilver, which is naturally a fluid substance, has been converted by cold into a compact body, capable of being hammered like a piece of lead. Nay, even some of the gases, or aerial fluids, show a disposition to congeal by a reduction of temperature. The oxygenized muriatic acid gas becomes concrete, and forms into crystals, at a temperature of near to that at which water freezes. All the gaseous substances, when they have lost their elasticity, by forming certain combinations, are disposed to assume the solid state if the temperature allow it. Ammoniacal gas, and carbonic acid gas become solid, as soon as they enter into combination; and hydrogen gas, the most subtle of the ponderable elastic fluids, forms, along with oxygen, that very water which is afterward congealed into ice. What is the reason, then, that the atmospheric air which we every moment breathe, is not subject to congelation? We know no other reason than the will of the Creator. Were we thoroughly acquainted with every particular respecting the nature of the gases of which it is composed, and the mode of their combination, we might, perhaps, discover the physical cause of this singular property; but still we should ultimately have to refer it to the Divine purpose and will that such a cause existed. We know that the vapors which are suspended in the higher regions of the atmosphere, are frequently congealed into hailstones of considerable size, and were

any large portions of the air around us to be congealed in a similar manner, it is easy to foresee what disastrous effects would quickly be produced; and were the whole atmosphere to be frozen into a solid body, destruction would inevitably seize upon all the tribes of the living world, and the beautiful face of nature we now behold, would be transformed into a chaos.

Such is the intimate connection that subsists between every part of the system of nature, and such is the exquisite mechanism with which all its parts are constructed and arranged, that if a single wheel or pinion of this vast machine were either wanting or deranged, the whole system would soon be dissolved and fall into ruins. But that Almighty Being who sits on the throne of the universe, presides over all its subordinate movements, preserves every element in its respective station, and directs the apparently jarring principles of nature to accomplish his wise and benevolent designs.

In fine, we may just farther remark, that man has acquired a certain degree of sovereignty over the atmosphere, by which he renders it subservient to his comforts, and to the execution of his designs. He causes it to sigh in the pipe, to complain in the flute, to thunder in the trumpet and the gong, and to utter a thousand melodious strains in the piano-forte and the organ. He causes it to announce tidings of joy or sorrow. He forces it to grind his corn, to blow his furnace, to winnow his grain, to raise water from the deepest pits, and to extinguish the flames when his buildings are on fire. He compels it to act as a prime mover in an endless variety of machinery, and by its agency, in combination with other powers, ten thousands of wheels and pinions are daily set in motion—power looms are weaving fabrics of various descriptions—spinning-jennies are set in action, steam vessels impelled along rivers, and across oceans—and railway trains carried forward in every direction with the most rapid motions. He yokes it to his ships, and compels it to expand the sails, and to waft him across the billows of the ocean to the remotest shores. And, in short, it is on the wings of the atmosphere that he raises himself, with his balloons, above the mountain-tops, looks down from on high on the dusky earth, and ranges at large through the region of the clouds.

Thus, a few of the beneficial effects produced by the atmosphere in the system of nature have been briefly stated. Its influence is essential to the germination and growth of plants, to the preservation of water in a state of fluidity, to the existence of fire and flame, to the respiration of all kinds of animals, to the process of evaporation, and the production of rain and dew; to support the clouds and to give buoyancy to the feathered tribes. It is the region of winds—the vehicle of smells—the medium of sounds, and the source of all the pleasures we derive from the harmonies of music; it is the cause of that universal light and splendor which are diffused around us, and of the advantages we derive from the morning and evening twilight; and all these advantages are more fully secured by the transparency of its particles, and by its being rendered incapable of being congealed into a solid body.

What, then, would be the consequences were the earth to be divested of its atmosphere? Were the hand of Omnipotence to detach this body of air from our globe, and could we suppose living beings at the same time to exist, the landscape of the earth would be disrobed of all its vegetable beauties, and not a plant nor flower would be seen over the whole face of nature; the springs

and rivers would cease to flow, even the waters of the mighty deep would be dried up, and its lowest caverns be exposed to view, like frightful and hideous deserts. No fire nor heat would cheer the abodes of man, either by day or by night, no rains nor dews would refresh the fields, no gentle zephyrs would blow, nor aromatic perfumes be wafted from blooming flowers. The birds would no longer wing their flight on high, nor would their warblings be heard among the groves. No sound whatever would be heard throughout the whole expanse of nature, universal silence would reign undisturbed over the world, and the delights of music be forever unknown. The morning would no longer be ushered in by the dawn, nor the day protracted by the evening twilight. All would be gloom and obscurity by day except in that quarter of the heavens where the sun appeared, and no artificial light nor flame could be procured to cheer the darkness of the night. The whole surface of the globe would present one wide prospect of barrenness and desolation, without a single object of beauty to relieve the horrors of the scene; and this earth, which now presents to the beholder so many objects of sublimity and beauty, would appear as if it had sunk into the primitive chaos whence it arose. But, as we are certain that, according to the present economy of the animal system, no living creatures could exist in such a state of things, it would be an inevitable consequence of the annihilation of the atmosphere, that all the myriads of living beings which now people the waters and the earth, would sink into remediless destruction, and the great globe we inhabit be transformed into one immense sepulcher, without enjoyment, motion, or life.

If, therefore, the Creator had not a regard to the happiness of his sensitive and intelligent offspring—or, if he wished to transform this globe into an abode of darkness and a scene of misery, he has only to support the functions of animal life on a new principle, and then to sweep from the earth the atmosphere with which it is now environed, and the dismal catastrophe is at once accomplished. Such a consideration shows us the propriety and the emphasis of the language of Inspiration, "In Him we live, and move, and have our being"—"In his hand is the soul of every living thing, and the breath of all mankind." But since we are assured that "the Lord is good to all: and his tender mercies are over all his works," and as we find no arrangement in the system of the universe whose ultimate object is to produce pain or misery to any sensitive being; we have no fear that such a catastrophe will ever be permitted to take place. At the same time, we know not what the great ends of his moral government may incline the Deity to perform. We know that, at one period, the system of nature connected with this globe was disarranged on account of the wickedness of its inhabitants, and a deluge of waters overwhelmed all the abodes of men. This catastrophe changed the aspect of the earth and atmosphere, and produced convulsions which shook the foundations of the earth, and disrupted its solid strata; the vestiges of which are still visible in every land, and form some of the subjects of scientific investigation. And, therefore, were the inhabitants of the world ever again to rise to the same pitch of wickedness as they did before the flood, we know not but the Almighty, instead of covering the earth with an abyss of water, might detach from it the surrounding atmosphere, and leave its inhabitants to the effect of such an awful catastrophe.

We learn from Revelation, that a period is ap-

proaching, "when the elements shall melt with fervent heat, the earth also, and the works that are therein shall be burned up." In the hand of Him who sits on the throne of the universe, the atmosphere is fitted to become the means of producing this tremendous event. The atmosphere, as formerly stated, consists chiefly of two fluids, or gases, of very opposite qualities; one of these, namely oxygen gas, is the principle of combustion, and forms about one-fifth part of atmospheric air; the other, namely nitrogen, instantly extinguishes every species of fire or flame. Were the nitrogen, then, which forms four-fifths of the

atmosphere, to be swept away, and the oxygen left to exert its native energies, all the combustible substances on the face of the earth would instantly take fire, nay, the hardest stones, the most solid rocks, and even water itself, would blaze under its force with such energy as to carry destruction throughout the expanse of nature. Such are the elementary principles in the hand and under the superintendence of the Almighty, which are ready at his command to bring into effect all the events, changes, and revolutions, in relation to our world, which are predicted in the word of Divine Revelation.

## CHAPTER VIII.

### THE WISDOM AND BENEVOLENCE OF THE CREATOR, AS DISPLAYED IN THE CONSTITUTION OF THE ATMOSPHERE.

As this topic has been partially alluded to in the preceding chapter, only two or three additional illustrations may now be given.

1. The wisdom and goodness of God are manifest in the proportion which subsists between the different gases of which the atmosphere is composed. Were the oxygen less in quantity than it now is—were it, for example, in the proportion of fifteen to eighty-five, in a hundred parts of nitrogen, instead of twenty-one to seventy-nine, fire would lose its strength, candles would not diffuse a sufficient light, plants would wither, and animals could not breathe without the utmost difficulty and pain. On the other hand, were the nitrogen diminished and the oxygen greatly increased, the least spark would set combustible bodies in a flame, and, in a few moments, they would be entirely consumed. Candles would be wasted in a few minutes after they were lighted, and would serve no other purpose than to dazzle our eyes with a transient blaze. Were a few houses in a large city set on fire such would be the rapidity with which the flames would spread on every side, that in a few hours, or even minutes, the whole city would be wrapt in one wide and unquenchable blaze, and no human art could arrest the progress of the destructive conflagration. In such atmospheric air, iron would be calcined, instead of acquiring from the fire that softness necessary for forming it into various instruments; it would accelerate to a dangerous degree the circulation of the fluids in animal bodies, and produce a degree of heat through the influence of which they would rapidly waste and decay. We know by experience that nitric oxide, which consists of forty-four parts of nitrogen and fifty-six of oxygen, produces instant suffocation in all animals that attempt to breathe it. We also know that the nitric acid, one of the most corrosive substances, is composed of seventy five parts oxygen and twenty-five parts nitrogen, which are only different proportions of the substances in atmospheric air; so that were the atmosphere composed of the same proportion of ingredients, our breathing it might produce the same effect as if we were to swallow a pint of aquafortis, or nitrous acid, which we all know would produce our immediate destruction. Can we, then, be at a loss to perceive, in the adjustment of the gases which compose our atmosphere, the wisdom and benevolence of the Deity;

and, at the same time, the infinite comprehension of the Divine Mind, in foreseeing all the effects that would be produced by the different combinations of these gases, and in selecting that particular combination for the atmosphere which is precisely adapted to the existence and the comfort of living beings?

2. The Divine wisdom and goodness are no less conspicuous in determining the relative specific gravity of these gases. The oxygen gas is found to be a little heavier than common air, and the nitrogen a little lighter, which enables it to rise to the higher regions of the atmosphere. In respiration (or breathing) there are four stages or periods:—1. Inspiration, or drawing in the air.—2. A pause when the lungs are filled.—3. Expiration, or breathing out the air from the lungs;—and 4. A pause when the lungs are emptied. In breathing, the air which is evolved from the lungs at every expiration, consists chiefly of nitrogen (and a small portion of carbonic-acid gas), which is entirely unfit to be breathed again, and therefore, by its levity, rises above our heads before the next inspiration. The pause which takes place between every inspiration is evidently intended to allow time for the nitrogen gas which is thrown out of the lungs to rise in the air, in order that a fresh portion of the atmosphere may be taken in, and that the same air may not be breathed again. During that remarkable interval, there is time left for the noxious fluids to separate, the nitrogen to ascend while the carbonic-acid gas preponderates, leaving a space between for a fresh current of pure atmospheric air to rush into the lungs. But what would be the consequence if nitrogen gas, instead of being a little lighter, had been a slight degree heavier than common air, or of the same specific gravity? Then we should not only have been obliged to breathe a portion of it again at every inspiration, but the vast quantity of it thrown off by the respiration of men and other animals would have perpetually occupied the lower regions of the atmosphere; and especially in our chambers it would have accumulated to such a degree as to have produced diseases, pestilence and death, in rapid succession. But, being a little lighter than the surrounding atmosphere, it flies upward, and we never breathe it again until it has entered into new and salutary combinations. Such is the benevolent skill which the

great Author of nature has displayed for the preservation and comfort of the human family and of every species of animated existence.

3. The wisdom of the Creator is displayed in the process for supplying the waste of oxygen, and promoting the renovation of the atmosphere. The quantity of carbonic-acid which is daily formed, by combustion and the respiration of animals, is so great, that it must have rapidly increased to a most dangerous extent, had not the Almighty provided means for its being as rapidly decomposed. It is well known that whenever atmospheric air becomes charged with one-tenth of this gas, it is unfit for promoting combustion, and is fatal to most animals that breathe it. Hydrogen too, and carbureted hydrogen gas, are perpetually evolved at the surface of the earth from various sources, particularly from marshes, dunghills, and stagnant pools; and these are likewise prejudicial, and even destructive, to the animal creation. On the other hand, oxygen gas, which is the support of fire and animal life, is continually wasted by the various processes of combustion, as in the case of furnaces, burning candles, and domestic fires, and by the breathing of all animals. How, then, has the Allwise Creator contrived to supply this waste, and to protect the inhabitants of the world from the baneful effects of the other gases with which the atmosphere is contaminated? The process appears to be this:—Vegetables are so constituted that carbon and hydrogen are the necessary food of plants, and are conducive to the support of vegetable life. Their vegetating organs seize the carbonic-acid gas that comes within their reach, and while they appropriate the carbon to themselves, the oxygen is thrown off to renovate the atmosphere, by its union with the nitrogen ejected by animal respiration. The leaves of trees, shrubs, and other vegetables, give out, during the day, a large portion of oxygen gas, which unites with the surrounding air, keeps up the equilibrium of the gases, and preserves the salubrity of the atmosphere; for it is found by experience that the air in every region, in the most crowded cities, as well as in the open fields, contains the same quantity of oxygen gas. Thus it appears, that what is noxious to man is rendered beneficial to the vegetable tribes, and the oxygen, of which they do not stand in need, is separated by them, in its utmost purity, for the use of man. The wisdom, the simplicity, and the beneficence of this arrangement, cannot fail to produce conviction in every reflecting mind, that the laws of nature are not to be referred to blind chance, but to unerring intelligence combined with boundless beneficence. In every breath we draw, we may perceive, if we reflect on the above stated arrangements, that we are every moment indebted to an all-wise and almighty Being, in whom we live and move, for the continuance of our existence and for every comfort we possess, and therefore praise, adoration, and thanksgivings, are due to him from all the ranks of his intelligent offspring.

The department of the subject already treated, may now be concluded with a reflection or two, founded on the statements previously made.

1. From the invisibility of the atmosphere, and its numerous and important effects in the system of nature, we may learn the folly of denying the reality of a future and invisible state of existence, because the objects connected with that state are not perceptible by our corporeal senses. Who could have imagined, previously to modern dis-

coveries, that all the functions of the vegetable kingdom, and all the comforts enjoyed by animated beings, are dependent upon the operation of a few invisible fluids, and that all the beauties of this lower creation are owing to the composition and decomposition, in a thousand different ways, of those gaseous substances whose operations are imperceptible to the keenest eye? And yet, the researches of modern chemistry have proved this fact to a demonstration, and shown us that every breath we draw, every pleasing sensation we feel, every portion of food we eat, every particle of heat that warms our apartments, every ray of artificial light that illuminates our streets and habitations, and every musical sound that enchants our ears, are owing to the unremitting motion and energy of invisible substances. And shall we, then, assert that the invisible principle of mind is not in existence or in action beyond the limits of this diurnal sphere, because its operation in that state lies beyond the range of our senses? We behold multitudes of rational beings daily departing from the living world; their organic frames crumbling into the dust, and the intellectual principle which animated them disappearing from mortal view. But we have no more reason to doubt that it is existing and operating in another sphere, than we have to doubt of the incessant energy of the invisible gases in giving life and beauty to sublunary nature. The disembodied spirits of men, whether existing in a pure ethereal form, or invested with fine material vehicles, may be employed in active services, and in sublime contemplations and investigations, of which we can at present form no adequate conception. We may, on the same grounds, form a conception of spirits suffering pains, anxieties, sorrows, and miseries, of different kinds, from a retrospective view of their former feelings, affections, and conduct, even when separated from those material organs with which they were formerly connected.

With regard to the great objects of religion, many of them lie beyond the range of our corporeal vision, as some of the agents employed in certain chemical processes elude our senses. Faith is described to be "the confident expectation of things hoped for, and the conviction of things which are not seen."\* It substantiates and realizes those objects which are invisible to the eye of sense, or which lie far beyond its present range of view. Hence we are told that, in the present world, we should "walk by faith, not by sight." The objects connected with a future world are real, although they are placed at such a distance as not to be cognizable by our present visual organs. They are not all merely of a spiritual nature, they are also connected with material objects; but, between our sensitive organs and such objects, immeasurable regions of space intervene. The glorified body of the Redeemer of mankind is a material substance and an object of sense, and it inhabits a region somewhere within the bounds of the material creation, but its distance from the sphere in which we now reside removes it from our view; and we want that vigor and energy of our corporeal organs which the martyr Stephen seems to have enjoyed, when the heavens were opened, and "he saw the glory of God, and Jesus standing on the right hand of God."

In certain pools of water, animalcules are found, whose bodies, when magnified a hundred thousand times their natural size, are visible only as so many moving points. A considerable portion

\* Doddridge's Translation of Heb. xi. 1.



of the watery element on our globe is filled with such invisible inhabitants, which have never been perceived by the millionth part of mankind. In this and similar instances, we have an invisible world of animated beings existing around us, but no one calls in question their existence because they can only be observed by powerful microscopes, and are not perceptible by the majority of mankind. In short, the Divine Being pervades every part of space with his essence, and is intimately present with every one of his creatures, yet remains forever invisible to mortal eyes. But, on this ground, no one but an atheist ever calls in question his existence. In like manner, the invisibility of the objects connected with a future world ought to form no ground of doubt respecting the certainty and reality of their existence.

2. We may learn what ought to be our great object in the study of the sciences, and in the investigation of the phenomena of nature.

Some persons are disposed to consider science and natural history merely as genteel studies; others apply their minds to such subjects with the view of bearing a part in the conferences of men of learning. Some, again, prosecute such pursuits for the purpose of making collections of scarce and valuable curiosities, and of displaying a degree of knowledge and taste superior to those of their neighbors; and the greater part of mankind consider such studies as only an amusement, or a relaxation of mind from the fatigues of their daily avocations. But the study of nature and of science is highly dishonored by such groveling and contracted views. The prospect of the universe was exposed to our view for more noble and exalted purposes—to make us wiser and better men, to expand our views of the perfections of our Creator, and to inspire us with a grateful sense of all the blessings we daily receive from his bountiful hand.

There are two great objects which we ought always to keep in view in our investigations of the laws of nature and of the principles which operate in the material world. In the first place, to deduce from our observation of physical facts, those principles by which the powers of man may

be extended—the useful arts improved and carried to perfection—and the comforts and enjoyments of mankind promoted and increased. In the next place, and chiefly, that our conceptions of the Creator's power, wisdom, benevolence, and superintending providence, may be enlarged, and that we may be more disposed to pay him that tribute of adoration and gratitude which is due to his name. Every study which sets the supreme Being on one side and nature on the other, is nothing more than an idle amusement—it is lost labor, and productive of little else than ignorance and error, pride and arrogance. To employ our thoughts on a thousand particulars in nature without directing them to the great Creator of all things—to profess to admire the displays of his wisdom, omnipotence, and goodness, while we violate his laws, and persist in a course of avarice or of dissipation—to be conscious of the blessings we every moment receive, and, at the same time, to be utterly unmindful of the hand from whence they flow—is a most glaring inconsistency, a shameful abuse of our understanding, and an act of the most flagrant ingratitude. All our knowledge is of no further importance to us than as it has an influence on our affections and conduct, and leads us to entertain impressive and reverential ideas of that almighty Being, “in whose hands our breath is, and whose are all our ways.”

Let us, then, for the air we breathe, and the numerous benefits we derive from the surrounding atmosphere, display our gratitude, and consecrate all our powers and faculties to the service of Him who “made the earth by his power,” and “hath established the world by his wisdom;”—who “causeth the vapors to ascend from the ends of the earth;” who “maketh lightnings with rain, and bringeth the wind out of his treasures,” and whose “tender mercies are over all his works.” To Him who hath created and redeemed us, all our powers and energies ought to be devoted from henceforth and forever, for he is worthy to receive all praise, honor, and dominion from men, from angels, and from the inhabitants of all the worlds dispersed throughout the regions of the universe

## PART II.

### ATMOSPHERIC PHENOMENA.

This is a subject which would admit of illustration sufficient to occupy a distinct volume; but the present limits will admit of only a very condensed and superficial view of the diversified objects connected with the phenomena of the atmosphere.

The atmospherical phenomena may be arranged under the following heads:—

- I. Aqueous meteors; as evaporation, rain, snow, hail, clouds, etc.
- II. Winds, sea and land breezes, monsoons, hurricanes, etc.
- III. Luminous and fiery meteors, as fire-balls, falling-stars, thunder and lightning, luminous arches, fata morgana, aerial specters, etc.

## CHAPTER I.

### AQUEOUS METEORS.

**I. EVAPORATION.**—This is a process by which water and other substances are converted into elastic fluids by the influence of heat or calorific. Vapors being lighter than air, are raised into the upper regions of the atmosphere, and afterward, by a partial condensation, form those clouds which we see floating around us. They are elastic, invisible substances, like common air, but lighter; being to common air, according to Saussure's experiments, as ten to fourteen. If we expose water to heat, bubbles at first adhere to the sides of the vessel, which by degrees ascend to the surface and burst. These bubbles rise the more rapidly in proportion to the heat. Water is evaporated by the heat of the sun merely, and even without it in the open air; and the vapor rising into the air is condensed into clouds. An immense quantity of vapor is, in this way, raised from the different regions of the earth. In order to estimate the quantity thus raised, Dr. Watson, bishop of Landaff, made the following experiments:—Having provided a large drinking-glass, the area of the mouth of which was twenty square inches, he placed it with its mouth downward on a grass-plot which was mown close. The sun shone bright and hot, and there had been no rain for upward of a month. When the glass had stood on the grass-plot one quarter of an hour, and had collected a quantity of condensed vapor, he wiped its inside with a piece of muslin, the weight of which he had previously ascertained, and, as soon as the glass was wiped dry, the muslin was weighed. The medium increase of weight from various experiments, between twelve and three o'clock, was six grains in one quarter of an hour, from twenty square inches of earth. At this rate of evaporation, computing seven thousand grains troy to one pint of water, and eight pints to a gallon, it may be shown that one thousand six hundred gallons of water would be raised from one acre of ground in twenty-four hours. It is evident that the quantity will be still greater when the ground has been drenched with rain. To prove this, the same philosopher made two other experiments, one of them the day after the ground had been wetted by a thunder-shower; and to ascertain the circumstances more exactly,

he took the heat of the earth by a thermometer laid on the grass, which in the first experiment was ninety-six degrees, when the evaporation was at the rate of 1775 gallons from an acre in twelve hours. The other experiment was made when there had been no rain for a week, and when the heat of the earth was 110 degrees; this experiment gave after the rate of 2500 gallons from an acre in twelve hours; the earth was hotter than the air, being exposed to the reflection of the sun's rays from a brick wall.

Hence it appears that evaporation must form a very important process in the economy of nature. The following are some facts in relation to this process. A much greater quantity of vapor rises during hot weather than during cold, as appears from the preceding experiments. Even where the temperature is the same, it varies according to circumstances. It is least of all in calm weather, greater when a breeze blows, and greatest with a strong wind. In our climate, the evaporation is about four times as great between the vernal and autumnal equinox as in the rest of the year. The degree of cold produced by evaporation is much greater when the air is warmer than the evaporating surface, than when the latter is the warmer of the two. From these and other facts, it is plain that tracts of land which are covered with trees are much colder than those where there is a less surface of vegetable matter, such grounds being found to emit one-third more vapor than the same space covered with water. Hence the important change of climate which a country undergoes by being cleared and cultivated. America is not the same country at present, either with respect to temperature or salubrity, as it was several centuries ago, when it was covered with woods.

By this perspiration of the globe, it has been estimated that thirty-six inches of water per annum are raised from the surface of all the seas and rivers, and at least thirty inches from all the regions of the land. Hence it follows, that by this constant process of evaporation, 100,000 cubic miles of water are, every year, raised into the atmosphere; the greater part of which, at a certain height, parts with its heat, and is condensed

**Into clouds.** Were this prodigious mass of water all to subsist in the atmosphere at once, it would increase about a twelfth part, and raise the barometer nearly three inches. But this never happens; no day passing without rain in some parts of the earth, so that part of the evaporated water is again constantly precipitated. The clouds formed by evaporation are carried by the winds over the land, broken, and precipitated by the action of mountains and trees, and thus rendered the means of watering the soil, and producing fertility throughout every region of the globe. It is owing solely to this process that our clothes, when washed and spread out to the open air, are soon dried. Were there no such process as evaporation in the system of nature, our linens and other clothes, when drenched in water, might remain for centuries without being dried—a circumstance which is seldom thought of by thoughtless men, but which demands our thanksgiving and gratitude. Hence we are called upon by the sacred writers to praise “the name of the Lord,” who “causeth the vapors to ascend from the ends of the earth.” Psalm cxxxv. 5.

2. **Clouds.**—The aqueous vapors, condensed by cold, or rising in the atmosphere to a region of air lighter than themselves, form strata of visible vapors, which we call clouds. These masses assume a great variety of shapes and configurations, which sometimes enliven the face of the sky, and at other times cause a gloom and shadow of darkness to overspread the landscape. The distance of the clouds above the surface of the earth varies at different times, and according to the nature of the cloud. Thin and light clouds frequently rise to the height of four or five miles, as they are sometimes seen above the tops of the highest mountains. Their average height may be reckoned about two and a half miles; but some dense clouds frequently descend so low as to touch mountains, hills, steeples, and even high trees, particularly during thunder-storms. The size of some of these clouds has been estimated to cover a space of fifteen or twenty square miles, and their thickness above a thousand feet. Their motions are generally directed by the winds, excepting when thunder is about to happen; in which case, they seem to move very slowly, and sometimes remain absolutely stationary, which is probably owing to their being impelled by two opposite currents of air.

Clouds have been arranged by modern naturalists into several classes, according to their different configurations, and the regions of the atmosphere where they are generally found. They have been distinguished by Howard into seven modifications, the peculiarities of which are supposed to be caused by the agency of electricity. There are three primary modifications—the cirrus, the cumulus, and the stratus; two which may be considered as intermediate in their nature—the cirro-cumulus, and the cirro-stratus; one which appears to be a compound—the cumulo-stratus; and, lastly, the cumulo-cirro-stratus, or nimbus, a state which immediately precedes the resolution of clouds into rain. These clouds are generally assigned to three atmospherical regions, the upper, the middle, and the lower one; to which a fourth, the low-st, may be added. In the upper region, the atmosphere is in such a state that it can receive and sustain only light and thin vapors, and to this district belongs the cirrus.

The cirrus has the least density of all the forms of cloud, but the greatest height and variety of shape and direction. It is the first indication of serene and settled weather, and first shows itself

in a few fibers spreading through the atmosphere. It sometimes looks like a fine whitish thread penciled on a clear blue sky. These fibers, by degrees, increase in length, and new fibers attach themselves to the sides. The duration of the cirrus is uncertain: in some kinds of weather, its figure is so rapidly and continually changed, that, after turning the eye from it for a few minutes, it will frequently be found almost completely changed. In other cases, it is sometimes visible for many hours and even days together, without much changing its appearance. From its usually curling appearance, this species of cloud is called the mare's-tail cloud.

The cumulus is a cloud of a dense structure, formed in the lower region of the atmosphere, and moving along in the current of wind which is next to the earth. Its first appearance is generally a small irregular spot, which increases in size, preserves a flat horizontal base, and assumes more or less of a conical figure. Such clouds are sometimes pretty well-defined hemispherical masses; at other times, they rise into mountains, ranged in one plane, their silvery summits presenting a beautiful appearance. Before rain they increase very rapidly, and descend low in the atmosphere. Great masses of them, during high winds, are seen in the quarter of the heavens toward which the wind blows, and indicate approaching calm and rain.

The stratus has a mean degree of density; it is the lowest of clouds, and its inferior surface frequently rests on the earth or on the water. The time of its appearance is about sunset, and it disappears soon after sunrise. It comprehends all those creeping mists which, in calm evenings, ascend in spreading sheets, like an inundation of water, from the bottom of valleys. Sometimes it remains quiet, and accumulates in layers, until the atmosphere is capable of sustaining its weight, when it assumes the position of the dark nimbus, and falls in a shower of rain.

The other species of clouds may be briefly stated, which are compound modifications. The cirro-cumulus consists of a collection of small white clouds, of a roundish form, which give to the sky the appearance called dappled, and are, in summer, considered as a prognostic of settled weather; or, at least, of an increase of temperature. They form a very beautiful sky, and are more frequent in summer than in winter. The cirro-stratus is generally in the form of long horizontal streaks, which are ever shifting their figure and position. It precedes wind and rain, the near or distant approach of which may sometimes be estimated from its greater or less abundance. It is frequently seen in the intervals of storms. The form and relative position, when seen in the distance, frequently give the idea of shoals of fish. It is that modification which most frequently exhibits the phenomena of the solar and lunar halo. The cumulo-stratus is a large, lofty, dense cloud, which may be compared to a mushroom, with a very thick, short stem. It rises through the interstices of the superior clouds; and the whole, seen as it passes off in the distant horizon, presents to the fancy mountains covered with snow intersected with dark ridges, rocks, towers, and other objects. Before thunder-storms, it frequently appears reddish. The nimbus is the cloud of rain. Before rain takes place, the clouds are uniformly found to undergo a change, attended with appearances sufficiently remarkable to indicate this as a distinct modification of clouds. It consists of a horizontal sheet, above which the cirrus spreads, while the cumulus enters it laterally, and from beneath.

Clouds are frequently highly charged with electricity. These not only produce violent storms of thunder and lightning, but are sometimes the cause of the destruction of life and the most dreadful devastations. In the year 1772, a bright cloud was observed, at midnight, to cover a mountain in the island of Java, which emitted flames of fire so luminous, that the night became as clear as day. It destroyed everything for twenty miles around: buildings were demolished, plantations buried in the earth; fifteen thousand cattle, a vast number of horses and other animals, and above two thousand human beings, were destroyed by the agency of this tremendous cloud. On the 29th of October, 1757, in the island of Malta, a little after midnight, a great black cloud appeared, which changed its color as it approached the city, until it became like a flame of fire, mixed with black smoke, and a dreadful noise was heard on its approach. It tore an English ship to pieces, and carried the masts, sails, and cordage, to a great distance. Small boats, in its course, were broken to pieces and sunk. In passing through the city, it laid in ruins everything in its way; houses were leveled with the ground, the roofs of churches were demolished; not one steeple was left in its passage, and the bells, together with the spires, were carried to a distance. In this awful catastrophe, the number of human beings killed and wounded amounted to nearly two hundred. Thus it appears that, while clouds serve occasionally as so many screens to abate the heat of the sun in warm countries, and form depositories of rains, which water and fertilize the earth, they are also sometimes used in the hands of the Almighty as instruments for the infliction of his judgments upon the nations; for the clouds are his chariots, the thunder his voice, and he "walketh upon the wings of the wind."

3. *Rain.*—We have already stated that the waters of the earth, by evaporation, yield a certain quantity of moisture to the air, which, being condensed, assumes the form of clouds, floating at different distances above us in the atmosphere. Whatever suddenly disturbs the heat or density of the air, or the electricity of the clouds, occasions the particles of vapor to rush together, and form drops of water too heavy to continue suspended in the atmosphere; they fall in the shape of rain, and increase in size as they fall, by combining with the floating vapors as they pass through them. We have but an obscure conception, however, of the chemical nature of vapor, and of the chemical processes which are going on in the production of vapor, and its subsequent resolution into rain. Dr. Thomson has this general remark on the subject, after quoting the opinions of Dr. Watson, Dr. Hales, and others, that "the formation of the clouds and rain cannot be accounted for by a single principle with which we are acquainted. It is neither owing to the saturation of the atmosphere, nor the diminution of heat, nor the mixture of airs of different temperatures; for clouds are often formed without any wind at all, either above or below them; and even if this mixture constantly took place, the precipitation, instead of accounting for rain, would be almost imperceptible." Instead, therefore, of detailing conflicting opinions on this subject, we shall state only a few general facts in relation to rain.

It is worthy of our notice, that drops of rain are always found larger in the lower regions of the atmosphere. In going down a high mountain in the time of rain, the drops gradually increase, until, reaching the bottom, they increase from a drizzling shower to a heavy rain. To ascertain

the generality of this fact, Dr. Heberden, in the year 1776, made the following experiment. He placed a rain-gauge on the square part of the roof of Westminster Abbey, another on the top of a neighboring house, considerably lower than the first, and another on the ground, in an adjoining garden. The rain collected in each was as follows:—top of Westminster Abbey, twelve inches; top of the house, eighteen inches; and on the ground, twenty-two inches; so that more rain was collected in the lower than in the upper rain-gauge. The proportions of rain vary in different months of the year. In summer, we have not so many rainy days as in winter; but the showers are then heavier, the streams of rain closer together, and the quantity which falls is greater than during any other season. Dr. Dalton states that the first six months of the year may be regarded as dry, and the last six as wet months. From certain long-continued observations, it has been inferred that, in spring, it rains oftener in the evening than in the morning; but that toward the end of the summer, oftener in the morning than in the evening; and that storms at this time are apt to occur a little after sunrise. In the progression of the seasons, rain falls at all times during the twenty-four hours, but it has been ascertained that much less falls by day than by night.\*

The annual quantity of rain is greatest in tropical countries, and diminishes as we approach the pole, owing to the greater evaporative qualities of the atmosphere in warm than in cold countries. Within the tropic, rain is not of the drizzling character of rain in the temperate zone, but generally falls in such torrents as in other zones would be called waterspouts, and they produce greater floods in a single day than in Europe in six days. Winter is distinguished from summer chiefly by the quantity of rain, which, for six months, is often constant for many days together, and lasts a certain number of hours per day. The rivers, in consequence, overflow, and in many countries produce inundations, which intercept all communications between neighboring towns and villages. The mean quantity of rain which falls annually in England is thirty-two inches. In the western parts of Scotland, the depth is from thirty to thirty-five inches; in the eastern parts, from twenty-four to twenty-eight inches. At Edinburgh, it is twenty-four inches and a half; and in London, twenty-two and one-fifth. There is more rain in the western part of Britain than in the eastern, because these parts receive the first clouds as they are brought from the Atlantic by the westerly winds. In the West Indies, one hundred and twenty inches fall annually; and, in the East Indies, from eighty to one hundred inches. At Bombay, eighty-two inches, and at Calcutta, eighty-one inches fall annually.

When mountain-ranges, and other distant objects, appear nearer to us than usual—when sounds are heard more clearly from a distance—when the odor of plants is more than usually powerful, rain may be soon expected. Ducks, geese, and other water-fowls, before the approach of rain, may be seen to throw water, with their bills, over their heads. Cattle may likewise be seen stretching out their necks, and snuffing in the air with distended nostrils. Dogs, closely confined in a room, become drowsy and stupid before rain; the same is observed in cats, though in a less degree; horses

\* It is said, that on the 29th of October, 1827, there fell, at Joyeus, in France, twenty-nine inches of rain in twenty-two hours; and, in eleven days, thirty-six inches; which is double that at Paris during the year.

neigh frequently; cattle low; the fallow-deer become restless; and swallows fly in a low course. Delicate persons are often affected, before rain, with headaches, pains in old sores which have healed, irritability of temper, the aching of corns, and excessive nervousness. Several flowers and plants are prognosticators of rain. When the flower of the chickweed closes, showery weather or continued rain may be expected. The trefoil, the convolvulus, and other plants, contract their leaves before the approach of rain. When the moon is of a pure silvery color, good weather is indicated; but when it has a brownish tint, rain may be expected. When stars are surrounded with colored halos, the approach of rain is indicated.

In the present constitution of our globe, rain—though sometimes attended with a few inconveniences—is essential for promoting the enjoyments both of man and beast. It moistens and softens the earth, and prepares it for being cultivated, and for affording nourishment to the vegetable tribes, which both adorn the landscape of the world, and afford nourishment to the human race and to every species of animated existence. By falling on high mountains, it carries down with it many particles of loose earth, which serve to fertilize the surrounding valleys, and purifies the air from noxious exhalations, which tend, in their return to the earth, to meliorate the soil. It moderates the heat of the air, and forms one of the sources whence fountains and rivers are supplied. Without the influence of rain, trees, shrubs, and flowers would soon wither, sicken, and die, and every land be then turned into a barren wilderness. But when the clouds, at seasonable periods, pour down their watery treasures, all sublunary nature is invigorated and refreshed, and the vegetable productions of the soil are made verdant and flourishing, and adorn the surface of the earth with their gay attire and diversity of colors. In the language of the Psalmist, “The little hills rejoice on every side. The pastures are clothed with flocks; the valleys also are covered over with corn; they shout for joy, they also sing.” He who at first formed the earth for man, “watereth the ridges thereof abundantly,” maketh it “soft with showers,” blesseth “the springing thereof,” and crowneth the year with his goodness.

It is represented by the inspired writers as the peculiar prerogative of Jehovah to send rain upon the earth: “Are there any among the vanities of the Gentiles that can cause rain? or can the heavens give showers? Art not thou He, O Lord our God?—for thou hast made all these things.” The effects produced by the want of rain are emphatically described by these writers: “Thy heaven that is over thee is as brass, and the earth that is under thee as iron.” “The field is wasted, the land mourneth; for the corn is wasted. \* \* \* Be ye ashamed, O ye husbandmen; howl, O ye vine-dressers, for the wheat and for the barley; because the harvest of the field is perished. The vine is dried up, and the fig-tree languisheth; the pomegranate-tree, the palm-tree also, and the apple-tree, even all the trees of the field, are withered. \* \* \* How do the beasts groan! The herds of cattle are perplexed, because they have no pasture; yea, the flocks of sheep are made desolate; \* \* \* for the rivers of waters are dried up, and the fire hath devoured the pastures of the wilderness.” Joel i. 10-12, 18, 20.

4. *Snow*.—Snow consists of such vapors as are frozen while the particles are small. It differs from hail and hoar-frost, in being crystallized, which they are not. When a flake of snow is

examined by a magnifying-glass, the whole of it will appear to be composed of fine shining spicula, diverging like rays from a center. As the flakes fall down through the atmosphere, they are continually joined by more of these radiated spicula, and thus increase in bulk, like the drops of rain or hailstones. Many of the flakes of snow are of a regular figure, for the most part stars of six points, and are as perfect and transparent ice as any we see on a pond or river. Their forms present an almost endless variety, are often very regular and beautiful, and reflect, with exceeding splendor, the rays of the sun. When they are very large, they are said to indicate the approach of thunder. The different forms which the flakes of snow exhibit, when viewed through microscopes, are represented in figure 6. These crystals of snow are from one-third to one thirty-fifth of an inch in diameter, in their natural size. Experiments have been made, which prove that snow is twenty-four times lighter than water, and that it fills up ten

Fig. 6.

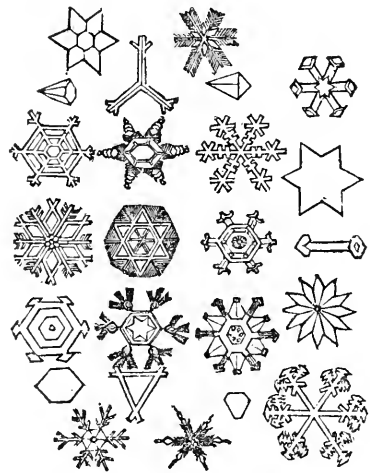

or twelve times more space at the moment of falling, than the water produced from it, when melted. It is worthy of remark, that previous to the fall of snow, and during its continuance, the temperature continues at about 32 degrees. The lightness of snow, although it is firm ice, is owing to the excess of its surface in comparison to the matter contained under it. Its whiteness is owing to the small particles into which it is divided; for ice, when pounded, will become equally white.

Snow is frequently formed in the lower regions of the atmosphere. A very cold stream of air admitted into a room in which the contained air is much warmer, and loaded with watery particles, will occasion its formation. In the huts of those who inhabit the arctic regions, snow is frequently formed in this manner. Dr. Robertson states that, in a crowded assembly-room in St. Petersburg, a stream of cold air was accidentally admitted into the room by a gentleman breaking a pane of glass, on which the vapor in the air was immediately congealed, and fell in the form of snow-flakes. In Siberia, Nova Zembla, and other northern regions, the same phenomenon frequently happens. Snow occurs in all regions of the globe at a certain height above the level of

the sea, but it falls more abundantly on plains as we proceed from the equator to the poles. In the arctic regions, snow falls nine days out of ten in the months of April, May, and June, and often to a depth of two or three inches in an hour. Among the mountains of Germany, Italy, and Switzerland, snow is sometimes accumulated to such an extent as to produce the most terrific and destructive effects, as in the case of the rolling avalanche. An avalanche is a mountain-mass of ice, or frozen snow, which is sometimes loosened from its base, and descends from the mountains with a force so terrible, that it crushes the traveler beneath its power, and buries hamlets and villages in a common grave. In the year 1749, the whole village of Rucras, in the canton of Grisons, in Switzerland, was covered, and at the same time, removed from its site, by an avalanche of this description. But this change, which happened in the night-time, was effected without the least noise; so that the inhabitants were not aware of it; and, on awakening in the morning, could not imagine why day-light did not dawn. A hundred persons were dug out of the snow, sixty of whom were still alive, the interstices between the snow containing sufficient air to support life. Not many years ago, an instance occurred of a family buried under one of these avalanches, and who continued in that situation for above a fortnight, remaining all that time in utter darkness, and incased in a body of snow several hundred feet in thickness. A massy beam supported the roof against this enormous pressure; and a milch ass, that happened to be thus incarcerated with the people, furnished sufficient nourishment for the support of life, until they were, at length, restored to the light of day.

The great Dispenser of universal bounty has so ordered it, that snow is eminently subservient, as well as all his other works, to his benevolent designs. As the winter cold is much more hurtful to vegetables than to animals, the plants would perish, if their roots were not preserved by some covering. God has, therefore, ordained that the rain, which in summer cools and revives the plants, should, in winter, fall in the form of a soft wool to cover the vegetables, and to guard them from the inclemency of frosts and winds. It prevents the internal heat of the earth from escaping, and forms a safe covering to the tender herb, until the winter cold has abated under the influence of the genial spring.

5. *Hail*.—Hail, which is a more compact mass of frozen water than snow, is formed by the congelation of vapor in the higher regions of the atmosphere. The drops of hail assume various figures, being sometimes round, at other times pyramidal, angular, thin, and flat, and sometimes stellated with six radii, like the small crystals of snow. When hail-stones are broken open, or cut across, they are sometimes found within to be of a spongy structure; sometimes the interior presents a very beautiful radiated appearance, and not unfrequently exhibits regular and very remarkable concentric plates. They are often of considerable dimensions. They vary in size from that of a small seed, to that of a boy's marble; and, in some instances, they have been found as large as the eggs of a goose; the small generally falling in the more northerly climates, and on the tops of mountains, and the larger in France, Spain, Italy, and other countries, toward the south of Europe. Hailstones have fallen in Scotland, which have been proved to weigh five ounces. In North America, they have sometimes been

picked up weighing fifteen ounces; and on October 5th, 1831, one fell at Constantinople which weighed more than a pound! The average velocity with which they fall, has been estimated at seventy feet per second, or at the rate of fifty miles an hour; and consequently, their great momentum, arising from this velocity, frequently renders them very destructive, particularly in hot climates. They beat down the crops, strip trees of their leaves, fruits, and branches, and sometimes kill even large beasts and men. A few years ago, a tremendous storm happened in Gloucestershire, accompanied with a most remarkable hail-shower. The masses of ice which fell in places where the storm most fiercely raged, bore no resemblance to the usual state of hail-stones in magnitude or *formation*, most of them being of a very irregular shape, broad, flat, and ragged, and many of them measuring nine inches in circumference. They appeared like fragments of a vast plate of ice, broken into small masses, by its descent toward the earth.

The phenomena attending the formation and fall of hail are but imperfectly understood, though it is certain they are connected with electricity, and hence, the frequent occurrence of hail-showers during violent storms of thunder and lightning. They occur principally in the temperate regions of the globe, less frequently between the tropics, and are almost unknown in the frigid zones. They are, also, more frequent in summer than in winter. In the south of France, and the adjacent countries, much damage has been produced by the ravages of hail-storms. To avert such ravages, hail-rods have lately been erected on the same principle as lightning rods. They consist of lofty poles tipped with metallic wires communicating with the earth. By thus subtracting the superabundant electricity of the clouds, it is supposed that the formation of hail might be prevented. It has been estimated by the "Linnean Society of Paris," from numerous experiments made in different districts, that "if these hail-rods were established through the whole of France, it would occasion an annual saving to the revenue of fifty millions of francs." It is also stated that, in many districts which were formerly year after year devastated by hail, the instrument has been adopted with complete success, while, in neighboring districts, not protected by hail-rods, the crops have been damaged as usual.

6. *Dew*.—Dew is vapor condensed into visible drops. It begins to be deposited about sunset, and is most abundant in valleys and plains near rivers and other collections of water, and abounds on those parts of the surface which are clothed with vegetation. In England, the dew is observed, like the drops of drizzling rain, upon the leaves of grass and other vegetables, upon wood, glass, porcelain, etc., or upon the earth, which is thereby rendered sensibly moist. It falls more copiously in spring and summer than at any other times of the year. In countries situated near the equator, the dews are generally observed in the morning throughout the year; and in some places in the east, where rain seldom falls, they are so copious, as, in a great measure, to supply its deficiency. During the heat of the day, a great quantity of vapor is thrown into the atmosphere from the surface of the earth and waters. When the evening returns, if the vapor has not been carried off by currents, it will happen that more remains diffused in the general atmosphere than the temperature of the night will permit to subsist. A decomposition of the aqueous atmosphere then commences, and is continued until the general

temperature and aqueous pressure arrive at an equilibrium, or until the returning sun puts an end to the process.

Hoar-frost, which appears like a powdery crystallization on trees and herbage, is only frozen dew. The conversion of dew into hoar-frost is another wise arrangement of Nature, by which

plants are protected from the severity of a freezing cold atmosphere. *Fogs* are clouds which float on the surface of the earth; and clouds are fogs in the higher regions of the atmosphere. From many elevated places they may be seen moving in the valleys, and from the valleys they may frequently be seen creeping along the sides of the mountains.

## CHAPTER II.

### WINDS.

1. *Winds in general.*—Wind is the motion of a body of air flowing from one place to another. The earth, being surrounded by a fine invisible fluid, extending several miles above its surface, is acted upon by heat and cold arising from different causes. This appears to be the general cause of the phenomena of winds; and, according to the force or velocity with which the masses of air move, we use the terms, a breeze, a gale, a storm, a tornado, a whirlwind, a hurricane, etc. When a fire is made in the open air, the rarefied part of that fluid will ascend in a current, and the cooler and denser air will rush in on all sides, in consequence of which a wind is generated, and blows constantly toward the fire. The wind thus produced will be too inconsiderable to be perceived at any great distance, but the rarefaction which arises from natural causes may be such as to agitate our atmosphere sufficiently to produce those torrents of air which have always a powerful effect in nature, and which sometimes overwhelm and destroy the fairest and most superb productions of human art. Among the causes which produce this rarefaction of the atmosphere, and generate wind, the heat of the sun is not the least powerful. When the solar rays, by their reflection from the earth's surface, have heated or rarefied a portion of the surrounding air, the air so rarefied ascends into the higher regions of the atmosphere, and the colder air, by which it was surrounded, moves forward in a sensible current to fill the vacuity. Likewise, when a condensation of vapor in the atmosphere suddenly takes place, giving rise to clouds which speedily dissolve in rain, the temperature of the surrounding air is sensibly altered, and the colder rushing in upon the warmer, gives rise to a sudden gust of wind. In regard to the particular causes which produce the various winds which prevail in different regions of the globe, different opinions have been entertained by philosophers. And, therefore, instead of examining theories and doubtful opinions on this subject, the writer will confine himself to the statement of a few facts respecting the different species of winds as they are found to operate in different countries.

2. *General or permanent winds.*—Winds are commonly divided into three classes, namely, general, periodical, and variable winds. General winds are those which are permanent, and blow always in the same direction, and have received the name of trade-winds. These winds prevail chiefly within the tropics, and a few degrees beyond. On the north of the equator their direction is from the north-east, varying at times a point or two of the compass each way. On the south of the equator, they proceed from the south-east. These winds constantly range in one direc-

tion, but never extend farther than  $30^{\circ}$  from the equinoctial, either north or south. In the Atlantic and Pacific oceans, under the equator, the wind is almost always easterly; more to the northward, it generally blows between the north and east; and, more to the southward of the equator, it blows between the south and east. The origin of these winds appears to be as follows:—the powerful heat of the torrid zone rarefies the air of that region; in consequence of this rarefaction, the air rises, and, to supply its place, a colder body of air from each of the temperate zones, moves toward the equator. But these north and south winds pass from regions where the rotatory motion of the earth's surface is less, to those where it is greater. Unable at once to acquire this new velocity, they are left behind; and, instead of being north and south winds, as they would be if the earth's surface did not turn round, they become north-east and south-east winds.

3. *Periodical winds, or monsoons.*—Those winds, which blow in a certain direction for a time, and, at certain stated seasons, change, and blow for an equal space of time from the opposite point of the compass, are called *monsoons*. During the months of April, May, June, July, August, and September, the wind blows from the southward or south-eastward over the whole length of the Indian ocean, namely, between the parallels of  $28^{\circ}$  north, and  $28^{\circ}$  south latitude, and between the eastern coast of Africa, and the meridian that passes through the western part of Japan; but, in the other months, October, November, December, January, February, and March, the winds in all the parts of the Indian ocean shift round, and blow directly contrary to the course they held in the former six months. These winds suffer partial changes in particular places, owing to the form and position of the lands, and other circumstances. When they shift, or when the south-west monsoon is about to commence, it is ushered in by vast masses of clouds from the Indian ocean, accompanied with violent blasts of wind, which are succeeded by floods of rain, during which, the lightnings flash without intermission, and the thunders roll with loud and deafening peals; and, when it ceases, the rain pours down in large volumes. This terrific commotion of the elements lasts for many days.

4. *Land and sea-breezes.*—These are another kind of periodical winds which are common on the coasts and islands situated between the tropics. During the day, the wind blows for a certain number of hours from the sea to the land; but, when evening arrives, it changes its direction, and blows as many hours from the land to the sea. The cause of these alternations appears to be as follows:—water, being a better conductor of heat

than earth, is always of a more even temperature. During the day, therefore, the land becomes considerably heated, the air rarefied, and, consequently, in the afternoon, a breeze sets in from the sea, which is less heated at that time than the land. On the other hand, during the night, the earth loses its surplus heat, while the sea continues more even in its temperature. Toward morning, therefore, a breeze regularly proceeds from the land toward the ocean, where the air is warmer, and, consequently, more rarefied than on the shore.

5. *Variable winds.*—In most countries to the north and south of the tropics, the winds are very irregular and uncertain, and vary in their direction at certain seasons of the year. In Germany, the east wind is most frequent at Gottingen, Munich, Weissemburg, Dusseldorf, Erford, and Buda; the south-east, at Prague and Wirtzburg; the north-east, at Ratisbone; and the west, at Mannheim and Berlin. Along the whole south-west of France, the wind blows most frequently from the north, north-west, and north-east; on the west coast, from the west, north-west, and south; and, on the north coast, from the south-west. In Great Britain, the north-east and south-west winds more frequently prevail, along with occasional north-west and south-east winds. From ten years' registers kept by the Royal Society, it appears that, in London, the winds blow in the following order: from the south-west, 112 days; north-east 58; north-west, 50; west, 53; south-east, 32; east, 26; south, 18; north, 16. From the same register, it appears that the south-west wind blows at an average more frequently than any other wind during every month of the year; that the north-east blows most constantly during January, March, April, May, and June, and that the north-west wind blows oftener from November to March, and more seldom during September and October, than any other months. In Scotland, the south-west is by far the most frequent wind over all the country, especially on the west coast. At Edinburgh, the westerly winds have been found to blow 230 days, and the easterly 135. At Saltecoats, in Ayrshire, the south-west wind blows three-fourths of the year, and along the whole coast of Moray, on the north-east side of Scotland, it blows for two-thirds of the year. East winds are common over all Britain, during April and May, but their influence is felt most severely on the eastern coast.

In our northern region, winds seldom excite much alarm, nor are they often attended with the disastrous results which are frequent in the tropical regions. It has, however, sometimes happened, even in England, that winds have produced the most appalling and destructive effects. In the great storm which happened on the 27th of December, 1703, the extraordinary power of the wind created a noise hoarse and dreadful, like thunder, which appalled every heart. Horror and confusion seized upon all, whether on land or at sea. One hundred and twenty-three persons were killed by the falling of dwellings, among whom were the bishop of Bath and his lady, by the fall of the episcopal palace. Eight thousand perished in the Severn and the Thames, and in ships blown away, and never heard of afterward. Land, houses, churches, corn, trees, rivers—all were damaged by its fury. Small buildings were swept away as chaff before the whirlwind; above 800 dwelling-houses were laid in ruins; 2000 stacks of chinneps were blown down in London; 15,000 sheep were destroyed on the banks of the Severn, and 20,000 in the county of Kent; 300 ships, 500

wherries, 300 ship-boats, and 100 lighters and barges, were entirely lost. The Eddystone Light-house was precipitated in the surrounding ocean, along with its ingenious architect and those that were with him. The damage done in the city of London alone, by this storm, was computed at above two millions of pounds sterling! Such are some of the dreadful effects of that invisible fluid which surrounds us, when put in rapid motion by the force of currents. Light as its particles seem to be, no human wisdom or power can, in such cases, avert its force, or withstand its dreadful and destructive agency, in allusion to which the Almighty is represented as riding "on the wings of the wind," and directing "the whirlwind and the storm."

6. *Noxious and poisonous winds.*—These winds prevail most generally in southern climes. Of these, the harmattan is a very singular wind, which blows periodically from the interior parts of Africa toward the Atlantic ocean. The season in which it prevails is, during the months of December, January, and February. It comes on at any hour of the day, and continues five or six days; and there are generally three or four returns of it every season. This wind is distinguished by a fog or haze, and extreme dryness; no dew falls during its continuance, vegetables wither, and the grass becomes dry like hay. The dryness is so extreme that the covers of books, though closely shut up in a trunk, are bent as if exposed to the fire. Household furniture is damaged, panels of wainscots split, and veneered work flies to pieces. The human body, likewise, feels the parching effects of the harmattan: the eyes, nostrils, lips, and palate, are rendered dry and uneasy; the lips and nose are inflamed, and there is a troublesome sensation of pricking heat on the skin. If the harmattan continue, the scarf-skin peels off, first from the hands and feet, and afterward from the rest of the body.

The sirocco is a wind which resembles, in some of its effects, the harmattan. It sometimes blows for several days together, and its medium heat is calculated at 112°; it is fatal to vegetation, and destructive to mankind, especially to those who are not natives of the country; it depresses the spirits in an unusual degree; it suspends the powers of digestion in such a manner, that those who venture to eat a heavy supper generally die during the night. The sick frequently sink under the pressure of their diseases, so that it is customary, in the morning after this wind has continued a whole night, to inquire who is dead. During the continuance of this wind, all nature appears to languish, vegetation withers and dies, the beasts of the field droop; the animal spirits are too much exhausted to admit of the least bodily exertion, and the spring and elasticity of the air appear to be lost. In the city of Palermo, in Sicily, where it frequently prevails, the inhabitants shut their doors and windows to exclude the air; where there are no window-shutters, wet blankets are hung on the inside of the windows, and the servants are kept constantly employed in sprinkling the apartments with water, and the streets and avenues of the city appear at such times to be nearly deserted. This wind is frequently felt in Greece, Italy, the Levant, and other parts of southern Europe; it is occasioned by currents of heated air from the deserts of Zahara in Africa; but happily it is not of long continuance. In Sicily, it seldom lasts longer than thirty-six or forty hours.

The samiel, or mortifying wind, is, perhaps beyond all others, dreadful in its effects. It gene-



rally blows on the southern coasts of Arabia, and the deserts near the city of Bagdad; and is supposed to have been the pestilence of the ancients, frequently killing all those who are involved in its passage. What its malignity consists in, none can tell, as no one has ever survived its effects to give information. It has been said that it frequently assumes a visible form, and darts in a kind of bluish vapor along the surface of the country. The natives of Persia and Arabia talk of its effects with terror; they describe it as under the conduct of a minister of vengeance, who governs its terrors, and raises or depresses it as he thinks proper. The camels, either by instinct or experience, have notice of its approach, and are so well aware of it, that they are said to make an unusual noise, and cover their noses in the sand. It blows over the desert in the months of July and August, and rushes with violence to the very gates of Bagdad, but never injures any person in the city. To escape its effects, travelers throw themselves as close as possible to the ground, and wait until it has passed by, which is commonly a few minutes. As soon as they who have life dare to rise up, they examine how it fares with their companions by pulling at their arms or legs; for, if they are destroyed by the wind, their limbs are absolutely mortified, and will come asunder. An extraordinary blasting wind is felt occasionally at Falkland's Islands, but it seldom continues above twenty-four hours. It cuts the herbage down as if fires had been made under it, so that the leaves are parched up and crumbled into dust. Fowls are seized with cramp, so as never to recover; and men are oppressed with a stopped perspiration, heaviness at the breast, and sore throats.

The simoon is a hot wind which prevails in Egypt, Arabia, Syria, and the adjacent countries. When it begins to blow in Arabia, the atmosphere assumes an alarming aspect. The sky becomes dark and heavy, the sun loses his splendor, and becomes of a violet color, and the air is thick from the subtle dust with which it is loaded. At first, the wind is light and rapid, and not remarkably hot; its temperature, however, soon increases, until it ranges at upward of 128°. When it occurs, all animated bodies discover it by the change it produces in them. The lungs are contracted and become painful, respiration is short and difficult, the skin parched and dry, and the body consumed by an internal heat. The streets are deserted, and the dead silence of night reigns everywhere. The inhabitants of towns and villages shut themselves up in their houses, and those of the desert in their tents, or in wells dug in the earth, where they wait the termination of this destructive heat. The only refuge travelers have from it is, to fall down with their faces close to the ground, and to continue as long as possible without drawing in their breath. Mr. Bruce thus describes it, in his journey through the desert:—"At eleven o'clock, while we contemplated the top of Chiggre, where we were to solace ourselves with water, Idris, our guide, cried out with a loud voice, 'Fall upon your faces, for here is the simoon.' I saw from the south-east a haze, in color like the purple part of the rainbow, which did not occupy twenty yards in breadth, about twelve feet from the ground, and it moved very rapidly, for I could scarce turn to fall upon the ground, with my head to the north, when I felt the heat of its current plainly on my face. We all lay flat on the ground as if dead, until Idris told us it was blown over. The meteor or purple haze which I saw was indeed passed, but the light air which still blew was of heat to threaten suf-

focation. For my part, I found distinctly in my breast that I had imbibed a part of it, nor was I free from an asthmatic affection until I was in Italy two years afterward."

Hurricanes are violent tempests of wind, accompanied with thunders and lightnings, rain, or hail. These fearful concussions of the atmosphere happen most frequently in the range of the West India Islands, and about the Cape of Good Hope. The forerunner of these hurricanes, when first seen, is only like a small black spot on the verge of the horizon, called by sailors the bull's eye. All this time a perfect calm reigns over sea and land, while at length, coming to the place where its fury is to fall, it invests the whole horizon with darkness. During its approach, a hollow murmur is heard in the cavities of the mountains, and animals, sensible of its approach, run over the fields to seek for shelter. Nothing can be more terrible than its violence when it begins. The sun, which, but a moment before, blazed in meridian splendor, is totally shut out, and a midnight darkness prevails, except that the air is incessantly illuminated with gleams of lightning, so vivid that one can see to read, and the rain pours down in torrents. All the elements seem to arm themselves for the destruction of human labors, and even of the scenes of nature herself. The velocity of the wind is such, that corn, vines, sugar-canes, forests, houses, boats, ships, are swept away, or buried in the deep.

A tornado is a sudden and violent gust of wind from all points of the compass. It partakes somewhat of the nature of a hurricane, but is still more violent in its effects. The winds seem to blow from every quarter, and settle upon one destined place, with such fury that nothing can resist their vehemence. When they have met in their central spot, the whirlwind begins with circular rapidity. The sphere every moment widens, as it continues to turn, and catches every object that lies within its attraction. The mariner, within the reach of its influence at sea, must try all his power and skill to avoid it, which, if he fail of doing, there is the greatest danger of his going to the bottom. Tornadoes most frequently rage along the coasts of Guinea, and other parts of western Africa.

Such are a few brief sketches of the phenomena of noxious and stormy winds. It is evident that they did not exist in the primitive state of our globe; for the operation of such agents of terror and destruction appears altogether inconsistent with the idea that man is at present in a paradisaical state, and possessed of that innocence and moral purity in which he was created. It appears incompatible with the idea of an Almighty Intelligence, possessed of boundless benevolence, that innocent beings should be so frequently subjected to the influence of such dreadful agents, by which they are swept from the living world in a manner so appalling and terrific. Man is, therefore, a creature who has fallen from his primitive state of integrity; and such fearful agents, and many others, as the volcano and the earthquake, are so many proofs and evidences of the depravity and fallen state of the human race; otherwise they would not be permitted to inhabit a world where so many destructive influences are in operation. An important change appears to have taken place in the constitution of the atmosphere at the period of the universal deluge, which probably may have given rise to many of the physical evils connected with this part of our terrestrial system; which may, in after ages, be in a great measure removed, when the earth shall be

cultivated throughout its whole extent, and universal peace and brotherhood prevail among all nations. Notwithstanding, however, the occasional operation of these destructive agents to which we allude, the arrangements connected with our globe, in their prominent bearings, and considered as a whole, evidently display the long-suffering, the tender mercy, and the goodness of Jehovah, and should lead us to humble ourselves in his presence, under a sense of our manifold deviations from the path of his commandments.

The velocity of winds varies, from the gentlest breeze or an imperceptible movement, to a hundred miles an hour. Light airs may be considered as moving at the rate of from one to three miles an hour, or from a foot and a half, to four feet and two-fifths, per second; a breeze, from four to six miles an hour; a brisk gale, from ten to sixteen miles an hour; a fresh gale, from twenty to twenty-

five miles; a strong gale, from thirty to thirty-five miles; a hard gale, from forty to forty-five miles; a storm or tempest, fifty miles; a great storm, sixty miles; a hurricane, eighty miles; a violent hurricane, tearing up trees, throwing down houses, etc., moves at the rate of one hundred miles an hour.

Notwithstanding the occasional ravages of winds, they produce many beneficial effects in the system of nature. They serve as ventilators for purifying the atmosphere; they dispel fogs and noxious vapors; they agitate the waters of the ocean, and prevent them from stagnation and putrefaction; in the heat of summer they fan us with gales and gentle breezes. By their mechanical force, windmills and other machinery are set in motion, and ships impelled across seas and oceans to the remotest corners of the globe, to promote commerce, learning, religion, and the mutual intercourse of human beings.

## CHAPTER III.

### LUMINOUS AND FIERY METEORS.

1. *The Aurora Borealis*.—This is one of the most splendid phenomena which appears in the visible sky, especially when its coruscations diffuse themselves over the whole face of the heavens. The appearances of the aurora may be arranged under the following particulars:—1. A horizontal light, like the morning twilight or break of day. This light generally appears in the north or north by west, and sometimes seems as if it broke out from a few darkish clouds. 2. Fine, slender, luminous beams, well-defined, and of a dense light. These frequently continue a half or a whole minute, apparently at rest, but more frequently with a quick lateral motion, that is, from east to west, or the contrary. 3. Flashes pointing upward, or in the same direction with the beams, which they always succeed. These are only momentary, and have no lateral motion, but they are generally repeated many times in a minute. They appear much broader, more diffuse, and of a weaker light than the beams; they grow gradually fainter until they disappear, and sometimes continue for several hours, flashing at intervals. Sometimes they are confined chiefly to the northern region of the heavens, and at other times illuminate the whole sky with their fantastic coruscations. Such are some of the general appearances of the aurora borealis, but they are strikingly varied at different times, and it is difficult accurately to describe the shifting and splendid phenomena they present.

The aurora has been occasionally seen in all ages: it is spoken of by Herodotus, Xenophon, Diodorus Siculus, Homer, Virgil, and Ossian, the Highland bard. Aristotle, in his work on meteors, describes it as "an appearance observed by night in calm weather, resembling flame mingled with smoke, or the distant appearance of burning stubble; the predominant colors being purple, bright red, and blood color." It has been more frequently observed in Great Britain since the year 1716, when, on the 6th of March, it appeared with a splendor which attracted universal attention, and was considered by many as prognostic of wars, famine and pestilence, and a foreign race of princes.

The following is a description of an aurora, as seen by Dr. Dalton:—"Attention was first excited

by the remarkably red appearance of the clouds to the south, which afforded sufficient light to read by at eight o'clock in the evening, though there was no moonlight in the north. From half-past nine to ten, P. M., there was a large luminous horizontal arch to the southward, and one or more concentric arches northward. At half-past ten o'clock, streamers appeared very low in the south-east, running to and fro from west to south; they increased in number, and began to approach the zenith apparently with an accelerated velocity, when all of a sudden the whole hemisphere was covered with them, and exhibited such an appearance as surpasses all description. The intensity of the light, the prodigious number and velocity of the beams, the grand intermixture of all the primitive colors in their utmost splendor, variegating the glowing canopy with the most enchanting scenery, afforded an awful, but, at the same time, pleasing and most sublime spectacle. Every one gazed with astonishment, but the uncommon grandeur of the scene lasted only one minute; the variety of colors disappeared, and the beams were converted into the flashing radiations; but even then it surpassed all other appearances of the aurora; in short, the whole hemisphere was covered with it."

The writer had occasion to witness a splendid and somewhat terrific display of this phenomenon, in the vicinity of Dundee, on the 17th November, 1835. A little before nine o'clock, P. M., the coruscations first began to appear, which in a short time diffused all the brightness which appears in a moonlight evening. About ten o'clock, the aurora shone in all its splendor, when coruscations, or streams of light, more than thirty or forty degrees in length, appeared to issue from a central point near the zenith, and to extend themselves in every direction, south, north, east, and west, like the meridians on an artificial globe. The most singular feature displayed by this aurora was that of a number of streams of light of a dark red color, like blood, and resembling expansive sheets of flame, which were seen in all directions mingling their streams with the more brilliant yellow coruscations, and giving to the whole celestial concave an appearance of terrific grandeur, which seemed to impress the mind of every

holder with awe and terror. This display continued during the night until four o'clock next morning, and was visible over the whole island of Great Britain. In London, it produced such an effect, that the policemen, ignorant of its nature, hurried to and fro through all the avenues of that city in search of fires, which they imagined had burst forth from every quarter. On the evening of September 29, 1847, about ten o'clock, a brilliant and rather uncommon aurora made its appearance, near Dundee. The sky was strongly illuminated in the north, and numbers of spiral coruscations shot upward toward the zenith. But its most striking peculiarity was that, on a sudden, and in a portion of the sky which was perfectly clear, an immense stream of light began to blaze with a quivering motion, like a huge serpent, or in a form like the letter S, extending forty or fifty degrees in length, and several degrees in breadth. Such streams of brilliant light, which appeared and vanished with all the rapidity of lightning, were to be seen over most regions of the sky.

This phenomenon appears more frequently, and displays itself in still greater splendor in the polar regions than in our country. It is also said that, in those regions, a hissing sound is heard during its continuance. During the long nights of winter in those countries, particularly in Lapland and Greenland, its radiations, along with the light of the heavenly bodies, are sufficient to guide the inhabitants in their journeys, and to enable them to engage in all the other avocations of life. In the northern parts of Siberia, the aurora begins with single bright pillars rising in the north, which gradually increasing, comprehend a large space in the heavens, rush about from place to place with incredible velocity, and at last cover almost the whole sky up to the zenith, and produce an appearance as if a vast tent were expanded in the heavens glittering with gold, rubies, and sapphires. It has been found likewise, that these brilliant phenomena are visible in the south polar regions as well as in the north. The general appearance of the aurora borealis is pretty well described by Thomson, the poet of the "Seasons."

"Silent from the north  
A blaze of meteors shoots; ensweeping first  
The lower skies, they all at once converge  
High to the crown of heaven, and all at once  
Relapsing quick, as quickly re-ascend  
And mix and thwart, extinguish and renew  
All ether coursing in a maze of light."

Various opinions have been formed as to the cause which produces the phenomena of the aurora. Most philosophers seem to agree that it is of an electrical nature, as its appearance can be imitated by artificial electricity. Dr. Faraday considers it as highly probable, "that it is a luminous accumulation of electricity flowing from the equator to the poles, for the restoration of electric equilibrium." But whatever may be the physical cause of the aurora, it presents to our view one of the most beautiful, sublime, and at the same time awful and mysterious phenomena which appear in our sky—while its coruscations sometimes cover with inconceivable magnificence, the concave of the whole hemisphere, changing their positions every moment, now resembling vast pyramids, or innumerable columns, now vanishing in a moment, leaving the heavens somber and black, and now returning with increased splendor, shedding a matchless glory over the heavens. Such striking phenomena evidently display the majesty and glory of the Creator and his power to cause the invisible elements of nature to produce the most

grand and diversified scenery—and although their mode of operation is not thoroughly discovered, they are, doubtless, intended to subservise beneficial purposes in the system of creation.

2. *Luminous arches.*—These are somewhat striking phenomena, which sometimes precede, or accompany the aurora borealis, but they make their appearance only at very distant intervals. The writer has seen only four or five of these arches within the space of the last thirty years. One of the most brilliant of the arches appeared on the 27th of August, 1846, and was first perceived a few minutes before nine o'clock in the evening. It was a grand and beautiful luminous arch, which stretched from one side of the heavens to the other, forming a most resplendent object in a clear and serene sky. Its highest point was about seventy-five degrees above the southern horizon—a little above the brilliant star Vega Lyra. Like all the other arches of this kind he has seen, it had a gradual motion downward toward the southern horizon, so that in the course of twenty minutes it was considerably below the star now mentioned. Its direction was from east by north, to west by south, or nearly at right angles with the magnetic meridian—which seems to indicate that it is connected with the operation of the magnetic principle. This is the exact direction of all the luminous arches now referred to, and they are all evidently connected with the appearance of the aurora borealis, and may be considered as a peculiar modification of this phenomenon. Its breadth was greater than that of a common rainbow; there appeared no prismatic colors, but a pure brilliant white, contrasting most beautifully with the deep azure of the sky. An aurora appeared at the same time in the north and north-west, but its coruscations were not very vivid, and continued only for a very short time. The arch began first gradually to disappear at its extremities, near the eastern and western horizon, and, about forty minutes after having been first seen, it was completely dissipated. The height of such phenomena above the earth has been variously estimated. Euler estimated them at 1000 miles; Boscovich, at about 800; Bergman, at 460; and Dr. Dalton, at 150 miles, which is, perhaps, nearest the truth. Whatever may be the height of the luminous arches, we have reason to believe that the elevation of the aurora borealis above the earth is the same, as they evidently are produced by the operation of the same cause.

3. *Fire-balls.*—These are a species of luminous or fiery bodies, which are occasionally seen to wing their flight through the upper regions, with a considerable degree of velocity and splendor. In tropical climates, these bodies are more frequently seen than in our more temperate regions. The following are a few brief descriptions of some of the meteors. Mr. Barham relates that, when he was riding in Jamaica, one evening, he beheld a ball of fire apparently about the bigness of a bomb, swiftly falling down with a great blaze. Approaching the place where it fell, he found the ground strangely broken up and plowed, and several holes appeared of the bigness of a man's head, and all the green herbage burned up near the holes; at the same time, a strong smell of sulphur. In the year 1676, a great globe of fire was seen at Bononia, in Italy, about forty minutes after sunset. It passed with a most rapid course, and at the rate of not less than one hundred and sixty miles a minute, and at last stood over the Adriatic sea. It crossed all Italy in its course, and by computation, it was found that it could not have been less than thirty-eight miles

above the surface of the earth. Wherever it approached, the inhabitants below could distinctly hear it, with a hissing noise, resembling that of a firework. It was heard to go off with a violent explosion. Its magnitude, when at Bononia, appeared twice as long as the moon, one way, and about as broad the other. It was estimated to be a mile long and half a mile broad.

One of the most striking and extraordinary meteors of this kind made its appearance on the 18th of August, 1783, about nine o'clock in the evening. It was seen in all parts of Great Britain, from the Shetland isles to the English channel, over all France, and the greatest part of Italy, and is supposed to have described a tract of at least one thousand miles over the surface of the earth. It appears to have burst and re-united several times, and the first bursting which was noticed was somewhere over Lincolnshire, in England. Its appearance produced universal wonder and alarm. When it was observed at Brussels, the moon appeared quite red, and the illumination was so great as totally to obliterate the stars. A report was heard some time after it disappeared, which was loudest in Lincolnshire, and afterward in the eastern parts of Kent. A hissing sound was said also to accompany its progress. At Greenwich, two bright balls, parallel to each other, led the way, and were followed by an expulsion of eight others. The balls were tinted first with a pure bright light, then followed a yellow mixed with azure, red, and green, which, with a coalition of bolder tints, and a reflection from the other balls, gave the most beautiful rotundity and variation of color with which the human eye could be charmed. The height of this fireball was reckoned at from seventy to ninety miles, its diameter was estimated at nearly two miles, and its velocity at about 1000 miles a minute. The same year, on the 4th of October, at forty-three minutes past six in the evening, another meteor appeared nearly of the same description, but much smaller and of shorter duration. It was first perceived to the northward as a stream of fire, like the common shooting stars, but large; and presently burst out into that intensely bright bluish flame, which is peculiar to such meteors. It was nearly globular, but left behind it a dusky red streak of fire. After moving ten degrees in this state, it became suddenly extinct without any explosion. Its height was estimated at between forty and fifty miles.

As to the physical causes which produce these extraordinary meteors, we are still in a great measure ignorant. The general opinion among philosophers is, that they owe their origin to the operation of electricity. The velocity with which these meteors wing their flight—the electrical phenomena attending them, the lambent flames and sparks proceeding from them—their connection with the aurora borealis, on whose appearance luminous balls have been seen formed and darting about with great velocity—and their general motions, which are constantly from or toward the north, or north-west—have been viewed as so many arguments corroborative of their electrical origin. Still it is difficult to account for all the phenomena exhibited by these bodies by electricity alone, since some of these bodies appeared to be of a denser and more compact structure than electricity could produce.

4. *Shooting or falling stars.*—These are meteors which are frequently seen darting through the sky, in the form of stars, and most frequently accompanied with a train of light. The nature of these bodies has not yet been well ascertained, and philosophers have of late been disposed to

alter their former opinions respecting them. It appears, from certain late observations made at Breslau by Professor Brandes and his pupils, that the height of some shooting stars is not less than five hundred miles, and that they move at the rate of eighteen miles in a second. A most extraordinary and wonderful display of the phenomena of shooting stars has of late occurred in different places, particularly in America. On the evening of the 12th and the morning of the 13th November, 1833, a shower of these meteors happened at Boston, New York, and other places, and their number was considered to equal one-half of the flakes which fill the air in an ordinary fall of snow. It was calculated that, in some places, they fell at the rate of 36,000 per hour, and the phenomena lasted more than seven hours. At Boston, the number of shooting-stars which were seen was estimated at two hundred and forty thousand. Similar phenomena, though not in such numbers, have appeared in various other places, and in the subsequent years, from the 12th to the 15th November, and hence they have been denominated the November meteors. M. Arago, the French philosopher, is of opinion, that such extraordinary phenomena cannot well be accounted for, unless it be supposed that, beside the planetary bodies which revolve around the sun, there are myriads of smaller bodies, which only become visible at the moment when they come within our atmosphere and assume a meteoric appearance; and that they move in groups, and also singly. Dr. Olmsted, of New Haven, who particularly investigated the meteoric showers of 1833, deduces the following among other conclusions:—That the distance of the body whence they emanated was about 2238 miles—that they entered the earth's atmosphere with a velocity of four miles per second—that some of the larger meteors must have been bodies of great size, not less than a mile in diameter—and, that they consisted of portions of a nebulous body which revolves around the sun, in one hundred and eighty-two days.

We may learn from such phenomena that, if the universe were not under the superintendence of a wise and benevolent Being, or if the powers of nature were left to act at random, the world in which we live might be subjected to manifold disasters from unknown bodies and unseen causes, from which we have hitherto been protected.

5. *Parhelia, or mock suns.*—A parhelia is a meteor in the form of a very bright light appearing on one side of the sun, and resembling that luminary. They generally seem about the size of the true sun, not quite so bright, though sometimes they are said to rival their parent luminary in splendor. When there is a number of them, they are not equal to each other in brightness, and externally they are tinged with colors like the rainbow. They differ in number and size; but they all agree in breadth, which is that of the apparent diameter of the sun. Appearances of this kind have been observed, both in ancient and in modern times, Gassendi, the Italian astronomer, relates, that in 1635 and 1636, he often saw one mock sun. Two were observed by M. de la Hire, in 1689, and the same number by Cassini, 1693; Mr. Grey, in 1700; Dr. Halley, in 1702; the Rev. Mr. Hamilton, in Dublin, in 1783; but the most remarkable appearances of this kind were seen at Rome by Scheiner; by Muschenbroeck, at Utrecht; and by Hevelius, at Sedan; by the former, four mock suns were observed, and by the latter seven.

The phenomenon of these meteors observed by Scheiner, at Rome, is represented at figure 7, in which a is the place of the observer; b, his zo-

nith; c, the true sun; A B, a plane passing through the observer's eye, the true sun, and the zenith.

Fig. 7.

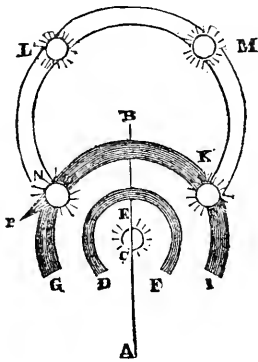

About the sun, c, there appeared two concentric rings, not complete, but diversified with colors. The lesser of them, D E F, was fuller and more perfect; and though it was open from D to F, yet those ends were perpetually endeavoring to unite, and sometimes they did so. The outer of these rings was much fainter, so as to be scarcely perceptible. It had, however, a variety of colors, but was very inconstant. The third circle was very large, and entirely white, passing through the middle of the sun, and everywhere parallel to the horizon. In the intersection of this circle, and the outward iris, G K I, there broke out two parhelia, N and K. The brightness of the middle of them was something like that of the sun, but toward the edges they were tinged with colors like the rainbow. The parhelion N was a little wavering, and sent out a spiked tail, N P, of a color somewhat fiery. The parhelia at L and M were not so bright as the former, but were rounder and white, like the circle in which they were placed. The parhelion N disappeared before K, and while M grew fainter, K grew brighter, and vanished the last of all. Parhelia have been visible for two, three, and four hours together, and in North America they are said to continue some days, and to be visible from sunrise to sunset.

6. *Thunder and lightning.*—These sublime and terrific phenomena are well known to every individual, and are occasionally displayed in every region of the globe. A thunder storm usually happens in calm weather, though sometimes it has been accompanied with furious winds. A dark cloud is observed to attract other clouds to it, by which it continually increases both in magnitude and apparent density; and when it has thus accumulated to a great size, its lower surface swells in particular parts toward the earth, and light flimsy clouds are sometimes seen flying under it, and continually changing their ragged shape. During the time the cloud is thus forming, the heavens begin to darken apace, the whole mass sinks down, wind arises, and frequently shifts in squalls, flashes of lightning are seen to dart from one part of it to another, and often to illuminate the whole mass and the surrounding landscape. When the cloud has acquired a sufficient expansion, the lightning strikes the earth in two opposite points; its paths lying through the whole body of the cloud. Heavy rains, and sometimes hail showers, accompany these dire phenomena, until, after numerous successive discharges, the cloud rarefies and the storm

ceases. The scene of a thunder storm is generally in the middle regions of the atmosphere; and it is not a frequent case that an electrical discharge is made into the earth. The lightning darts from one cloud into another, and when the clouds are high, there is no danger to persons or objects on the surface of the earth. But when the cloud is low, and within the striking distance of the earth, when the flashes appear to strike perpendicularly, and when only a second or two elapse between seeing the flash and hearing the report of the thunder, every object around may be considered as within the limits of danger; for then the lightning strikes into some parts of the earth, and every object in the line of its course is liable to be injured. We may ascertain the distance of a thunder-cloud, by counting the number of seconds or pulsations that intervene between seeing the lightning and hearing the first sound of the thunder, allowing about 1142 feet, or 380 yards for every second. Thus, if two seconds intervene, the distance is 760 yards; if three seconds, 1140 yards, if four and a half seconds, 1710 yards, or nearly a mile, etc. During a thunder storm, the lightning sometimes assumes different forms. Sometimes it appears as balls of fire, moving with great velocity: this is the most dangerous species of lightning, and where they strike, corn-yards are set on fire, and sometimes flocks of sheep, herds of cattle, and human beings are instantly killed. Another form is that of zigzag lightning, which most frequently accompanies thunder storms. It is likewise destructive, but not to the same extent as the ball-lightning. The next species is the sheet-lightning, which appears in the form of a lambent flame, or a sudden illumination, without any determinate form. It is never known to do any injury.

As to the cause of thunder storms, it is now ascertained, beyond dispute, that lightning and electricity are identical. This had been long ago surmised, after the attention of philosophers had been directed to the subject of electricity. It was observed that lightning, in its course, took the best conductors of electricity, such as bell-wires, and gildings; that it burned, exploded, and destroyed conducting substances, as electricity does; that it struck the most elevated objects, as trees and spires; that the crooked form of zigzag lightning was similar to that of an electric spark; and that it affected the nervous system, and changed the polarity of the mariner's needle, as electricity was found to do. This was, at last, put to the test of experiment by Dr. Franklin, by elevating during a thunder storm, a kite, with a metallic point on the head of it, when he drew an electric spark from the cloud by means of a key, connected with the wet string, which was connected with the kite. Nearly at the same time an experiment, somewhat similar, was performed by M. Dairibard, at Marly de Ville, about fifteen miles from Paris. These experiments were made in 1752, and since that period, lightning, and the electric matter, have been considered as the same; though there are still many phenomena connected with thunder storms of which we are ignorant. The grand practical use to which Dr. Franklin applied his discovery, was to secure buildings from being damaged or destroyed by lightning; which is accomplished by fixing a pointed metallic rod higher than any part of the building, and communicating with the earth. This wire the lightning will seize upon, in preference to any other part of the building, by which it is conducted to the earth without injuring the inhabitants.

*Maxims during a thunder-storm.*—When in the

open fields, avoid trees, but be near them—say at the distance of thirty or forty feet—as high objects are more likely to be struck with lightning than those which are low. When walking in the open air, avoid ponds, rivers, streamlets, and every mass of water; for water, being a conductor of electricity, might determine the lightning to the place we occupy. Do not avoid rain, as it is safer, in a thunder-storm, to be completely drenched than otherwise. When in a house, persons should avoid sitting near the fireplace, as it brings us in connection with the highest part of the building, and which contains such conducting substances, as the grate, the fender, and fire-irons. Bell-wires, mirrors, gildings, lusters, and other metallic substances, should also be avoided. The safest position is in the middle of a large room, at a distance from conducting substances, with our chair placed on a mattress.

In the preceding pages, we have taken a cursory survey of the nature and properties of the atmosphere, and of the phenomena it frequently presents, and have noticed the evidences of Divine wisdom and beneficence as displayed in the arrangements connected with this admirable appendage to our globe. A devout contemplation of this subject is worthy of the serious attention of every rational and Christian mind; for all the works of God are intended to display to intelligent beings certain parts of the character and attributes of the Almighty, and to inspire us with love and gratitude for those merciful and benevolent arrangements by which our lives are preserved, and our happiness and comforts secured. The system of the material world, in all its varieties, may be considered as one of the revelations given by God to man, in order that we may trace, from his external operations, visible to every eye, something of the nature of that Almighty Being who at first brought all things into existence, and who, every moment, superintends all their movements. Hence we are informed, by an inspired writer, that the “invisible things of Him from the creation of the world are clearly seen, being understood by the things that are made, even his eternal power and Godhead.”

Had man continued in primeval innocence, in the complete exercise of his moral and intellectual faculties, this would, perhaps, have been the only revelation of which he stood in need. But, in his present fallen state, the investigation and study of the material world are not sufficient to lead him to the knowledge of the true God, and to guide him in the way that leads to immortal happiness. Hence it happened that even the wisest sages of antiquity, who were destitute of any other revelation, completely failed in attaining to just conceptions of the Eternal Divinity, of the worship and homage he required, of the duties they ought to perform, and of their eternal destination. “Professing themselves to be wise, they became fools, and changed the glory of the incorruptible God into an image made like to corruptible man, and to birds, and to four-footed beasts, and creeping things.”

The religion of nature is glaringly deficient in directing us to correct views of the attributes of the true God, and particularly of the conceptions we ought to form of his moral character, as a Being possessed of strict and impartial justice and eternal rectitude, and whether he be disposed to the exercise of mercy and love. Hence, some of the ancient philosophers denied his existence, and others embraced the notion of a multiplicity of gods, celestial, aerial, terrestrial, and infernal; and the moral characters and actions attributed to such

deities were distinguished for everything that was wicked, base, cruel, and licentious. The light of nature can afford us no certain and indubitable evidence of the immortality of the soul, a future state of eternal rewards and punishments, or of a future and glorious resurrection: for many opposite and discordant opinions prevailed on this subject among those who were destitute of Divine revelation; some of them absolutely denying the existence of such a state as a vulgar error; while others represented it as altogether uncertain, having no solid foundation for its support. The light of nature can convey no proper notion of a creative Power that could produce the universe out of nothing, nor of the time and manner in which the world was created and arranged. Hence, one sect of heathen philosophers held that the world was eternal; and another, that it was formed in its present admirable order by a fortuitous concourse of innumerable atoms. It can afford us no certain information respecting the origin of evil, and the cause of that depravity and misery, which exist among mankind; and, in short, it can point out no method by which those who have offended God may be certainly restored to his favor, and a reconciliation effected between God and man; so that his mercy may be exercised without the violation of his justice, and the pardon of sinners rendered consistent with the honor of his laws and the wisdom and equity of his government. From nature, therefore, there arises no sufficient comfort to sinners to warrant hopes of forgiveness; but, on the contrary, anxious and endless solicitude about the means of appeasing the Deity. Hence the various modes of sacrificing, and the numberless superstitions which overspread the heathen world, but which were unsatisfactory to the wiser part of mankind, even in the times of pagan darkness and ignorance.

While ignorant of the important and interesting truths now adverted to, we can enjoy no solid happiness in the present state, nor any cheering prospects in reference to a future and eternal world. But, on all these subjects, so interesting to every human being, the Christian revelation throws an effulgence of light and evidence, and affords every satisfaction to the anxious mind which it can desire. It has “brought life and immortality to light,” and shed a radiance over the mansions of the tomb, and the scenes of a future world; it has unraveled the origin of evil, and the cause of all those miseries and moral abominations which have prevailed in the world; and, above all, it has disclosed the gracious purposes of the God of mercy and love toward our fallen and apostate world, and opened the way by which sinners may be pardoned and restored to the Divine favor, in full consistency with all the perfections of the Divinity, and the honors of his universal government. For thus runs the declaration of the Most High to all the children of men: “God so loved the world that he gave his only begotten Son, that whosoever believeth in him should not perish, but have everlasting life.” He sent his Son into our world, as a messenger of peace, “to bear the sin of many,” “to bring in everlasting righteousness,” to make “intercession for the transgressors,” to vindicate the honors of his broken law, to abolish death, and to open the way to the mansions of glory in the heavens, to men of all nations, kindreds, and languages, who receive the record he hath given of his Son, and submit to the method of salvation he hath devised. He hath set forth his Son to the world to be “a propitiation through faith in his blood, to declare his righteousness for the remission of sins, . . .

that he might be just and the justifier of him which believeth in Jesus." It is, therefore, "a faithful saying, and worthy of all acceptation, that Christ Jesus came into the world to save sinners," even the chief. And all who receive the salvation thus proffered, will consecrate themselves to his service, and, by the aid of the Holy Spirit, prosecute a course of obedience, "denying ungodliness and worldly lusts," and living "soberly, righteously, and godly in the present world." Every sin and violation of the Divine law will be carefully avoided; every holy disposition, every heavenly temper, and every Divine virtue and grace will be sedulously cultivated; love to God and man will pervade all the faculties of the soul, and be displayed in the general tenor of the conduct; and, by pursuing such a course of action, the individual will be gradually prepared for the nobler contemplations and exercises of that higher sphere of existence, where there is "fullness of joy," and "where there are pleasures forevermore."

From what we have now stated, we may fairly conclude, that all our contemplations of the works of nature, and all our investigations of the system of the visible creation, ought to be conducted in connection with the views and discoveries unfolded by Divine revelation. The two revelations which God has made to us, when properly studied, will be found not only in perfect harmony, but to throw a mutual light on each other; so that what may appear deficient in one is supplied by the other. While we contemplate the manifestations of Divine power, wisdom, and goodness, in the arrangements and operations of nature, we perceive the same attributes illustrated in the records of revelation; and, in addition to these, we perceive what nature cannot teach us, that God is a Being of perfect and eternal rectitude, of inviolable faithfulness, of boundless benevolence; ready to forgive, and rich in mercy to all who call upon him in truth:—a Being who fills immensity of space with his presence, who possesses the most intimate knowledge of all creatures and events throughout creation, and who superintends all the movements of the material universe. To whatever scene of nature we direct our attention, we find sentiments in Scripture adequate to express every emotion of the soul while engaged in such contemplations. Are we contemplating the immense number and variety of animated beings which people the earth, the waters, and the air, and the ample provision made for their accommodation and subsistence—where can we find language more appropriate to express our feelings than in these words of the Psalmist, "O Lord, how manifold are thy works, in wisdom hast thou made them all: the earth is full of thy riches! So is this great and wide sea, wherein are things creeping innumerable, both small and great beasts.—These wait all upon thee; that thou mayst give them their meat in due season. That thou givest them—they gather; thou openest thy hand—they are filled with good." When we survey the structure of the human frame, and consider the vast number of bones, muscles, veins, arteries, lacteals, and other parts, all curiously combined, performing such a variety of functions, and all contributing to life and enjoyment—can we refrain from adopting the expressive language of the Psalmist? "I will praise thee; for I am fearfully and wonderfully made: marvelous are thy

works!—how precious are thy thoughts unto me, O God! how great is the sum of them! If I should count them they are more in number than the sand." When we consider the amazing structure of the heavens—the immense magnitude and number of the mighty orbs contained within the canopy of the sky—that millions upon millions of suns and worlds stretching into the immensity of space far beyond the limits of our vision, or even of our imagination, form only a small portion of the universal empire of the Almighty; and when the mind is overwhelmed and lost, on the view of this stupendous scene—where shall we find language to express our emotions, more emphatic and appropriate, than in such passages as these? "Canst thou by searching find out God? Canst thou find out the Almighty unto perfection? Great is our Lord and of great power: his understanding is infinite;—his greatness is unsearchable.—The heavens declare the glory of God; and the firmament showeth his handiwork.—All nations before him are as nothing; and they are counted to him less than nothing, and vanity—who doeth great things past finding out; yea, and wonders without number.—Great and marvelous are thy works, Lord God Almighty! Who can utter the mighty acts of the Lord? Who can show forth all his praise?"

In short, the man who recognizes the truths of Divine revelation must feel a higher degree of pleasure and satisfaction in contemplating the scenes of creation, than the man who either discards or overlooks the revelations contained in the sacred oracles. To a man who is hastening to the grave, uncertain whether his intellectual powers and consciousness shall exist beyond the limits of the present state—of what avail is it that he has acquired a partial knowledge of some of the departments of the visible world, when all his knowledge shall be lost at the hour of dissolution, and no further prospect remains of his ever again resuming such studies and investigations, and of beholding the mysteries and wonders of the universe more fully unfolded? He may be filled with wonder at many of the astonishing processes going forward in the animal, vegetable, and mineral kingdoms; his mind may be overpowered with admiration and astonishment at the vast extent of the material universe, and at the myriads of worlds it contains, but he can entertain no hopes of seeing such wondrous scenes more fully unraveled and displayed in the light of immortality. But the Christian, who looks forward to the nobler employments of a future world, may with certainty indulge in the hope that in the light of that world, the veil which now intercepts our view of the wonders of creation will be removed, and the glories of the Divinity, as displayed in all his works, more fully unfolded. For the inhabitants of that world are represented as celebrating the perfections of the Most High in such strains as these—"Great and marvelous are thy works, Lord God Almighty!" evidently indicating that the veil is partially removed from the hidden scenes of creation, and their minds expanded to take in large and comprehensive surveys of the wonders of the universe, so as to perceive them to be "great and marvelous." And again, they exclaim, "Thou art worthy, O Lord, to receive glory, and honor, and power; for thou hast created all things, and for thy pleasure they are and were created."



















